

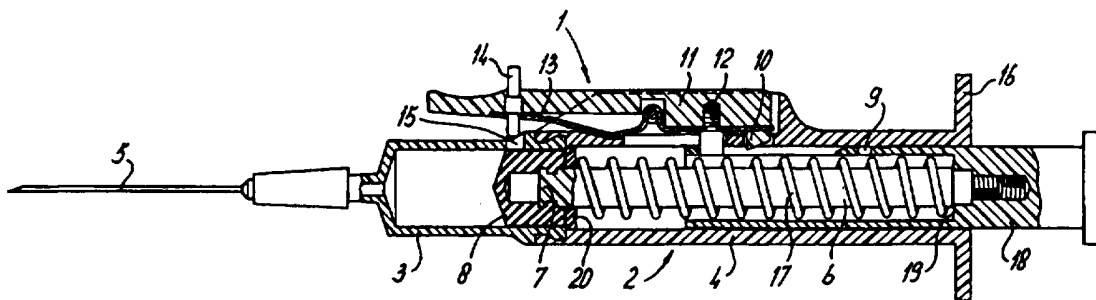

INTERNATIONAL APPLICATION PUBLISHED UNDER THE PATENT COOPERATION TREATY (PCT)

<p>(51) International Patent Classification⁶ : A61B 10/00</p>	<p>A1</p>	<p>(11) International Publication Number: WO 96/28097 (43) International Publication Date: 19 September 1996 (19.09.96)</p>
<p>(21) International Application Number: PCT/NL96/00111 (22) International Filing Date: 12 March 1996 (12.03.96) (30) Priority Data: 9500524 16 March 1995 (16.03.95) NL (71)(72) Applicant and Inventor: OOSTERHOF, Okko, Nanning [NL/NL]; Vestdijklaan 452, NL-9721 ZM Groningen (NL). (74) Agents: DE BRUIJN, Leendert, C. et al.; Nederlandsch Octrooibureau, Scheveningseweg 82, P.O. Box 29720, NL-2502 LS The Hague (NL).</p>		<p>(81) Designated States: AL, AM, AT, AU, AZ, BB, BG, BR, BY, CA, CH, CN, CZ, DE, DK, EE, ES, FI, GB, GE, HU, IS, JP, KE, KG, KP, KR, KZ, LK, LR, LS, LT, LU, LV, MD, MG, MK, MN, MW, MX, NO, NZ, PL, PT, RO, RU, SD, SE, SG, SI, SK, TJ, TM, TR, TT, UA, UG, US, UZ, VN, ARIPO patent (KE, LS, MW, SD, SZ, UG), Eurasian patent (AM, AZ, BY, KG, KZ, MD, RU, TJ, TM), European patent (AT, BE, CH, DE, DK, ES, FI, FR, GB, GR, IE, IT, LU, MC, NL, PT, SE), OAPI patent (BF, BJ, CF, CG, CI, CM, GA, GN, ML, MR, NE, SN, TD, TG).</p> <p>Published <i>With international search report.</i> <i>In English translation (filed in Dutch).</i></p>

(54) Title: ASPIRATION INSTRUMENT FOR CELL BIOPSY PURPOSES



(57) Abstract

Aspiration instrument for cell biopsy purposes, comprising: a cylinder (3) which at the distal end is provided with means for fastening a hypodermic needle (5), a plunger (6) whose distal end is in the form of a piston (8), which piston (8) is movable in the cylinder (3) between a first position and a second position, guide means (4) for guiding the plunger (6), pre-compression means (17) by means of which the plunger is pre-compressible in the direction of the first position, which pre-compression means (17) are activated when the plunger (6) is moved from the first to the second position, locking means (9, 10) by means of which the plunger (6) can be locked in the second position, means for unlocking the locking means, in order to make the plunger (6) move from the second to the first position under the influence of the pre-compression means (17), in which the plunger (6), the guide means (4) for the plunger, the pre-compression means (17), the locking means and the unlocking means therefor are combined to form a unit (2) to which the cylinder (3) is detachably connected, which unit (2) is made of sterilizable material.

FOR THE PURPOSES OF INFORMATION ONLY

Codes used to identify States party to the PCT on the front pages of pamphlets publishing international applications under the PCT.

AM	Armenia	GB	United Kingdom	MW	Malawi
AT	Austria	GE	Georgia	MX	Mexico
AU	Australia	GN	Guinea	NE	Niger
BB	Barbados	GR	Greece	NL	Netherlands
BE	Belgium	HU	Hungary	NO	Norway
BF	Burkina Faso	IE	Ireland	NZ	New Zealand
BG	Bulgaria	IT	Italy	PL	Poland
BJ	Benin	JP	Japan	PT	Portugal
BR	Brazil	KE	Kenya	RO	Romania
BY	Belarus	KG	Kyrgystan	RU	Russian Federation
CA	Canada	KP	Democratic People's Republic of Korea	SD	Sudan
CF	Central African Republic	KR	Republic of Korea	SE	Sweden
CG	Congo	KZ	Kazakhstan	SG	Singapore
CH	Switzerland	LI	Liechtenstein	SI	Slovenia
CI	Côte d'Ivoire	LK	Sri Lanka	SK	Slovakia
CM	Cameroon	LR	Liberia	SN	Senegal
CN	China	LT	Lithuania	SZ	Swaziland
CS	Czechoslovakia	LU	Luxembourg	TD	Chad
CZ	Czech Republic	LV	Latvia	TG	Togo
DE	Germany	MC	Monaco	TJ	Tajikistan
DK	Denmark	MD	Republic of Moldova	TT	Trinidad and Tobago
EE	Estonia	MG	Madagascar	UA	Ukraine
ES	Spain	ML	Mali	UG	Uganda
FI	Finland	MN	Mongolia	US	United States of America
FR	France	MR	Mauritania	UZ	Uzbekistan
GA	Gabon			VN	Viet Nam

Aspiration instrument for cell biopsy purposes

The present invention relates to an aspiration instrument for cell biopsy purposes, comprising:

5 a cylinder which at the distal end is provided with means for fastening a hypodermic needle,

a plunger whose distal end is in the form of a piston, which piston is movable in the cylinder between a first position and a second position,

10 guide means for guiding the plunger,

pre-compression means, by means of which the plunger is pre-compressible in the direction of the first position, which pre-compression means are activated when the plunger is moved from the first to the second position,

15 locking means by means of which the plunger can be locked in the second position,

means for unlocking the locking means, in order to make the plunger move from the second to the first position under the influence of the pre-compression means.

20 Such an aspiration instrument is known in practice and is described in a brochure obtainable from Cooper Companies Inc., established at One Bridge Plaza, Fort Lee, New Jersey 07024, USA. The known aspiration instrument is designed for the collection of cell material from subcutaneous tissue for purposes of cytological
25 research. The known aspiration instrument is made ready for use by fastening a hypodermic needle to the cylinder and subsequently depressing the plunger against the force of the pre-compression means until the plunger is locked in the second position. During this process pre-compression means are pre-compressed. The piston is now
30 situated at the distal end of the cylinder. The hypodermic needle can then be introduced into the tissue to be examined, following which the locking can be undone simply by a finger movement. Under the influence of the compressed pre-compression means, the plunger - and thus the piston - moves back to the first position, while a partial vacuum is
35 created in the cylinder, as a result of which cell tissue is aspirated. When sufficient cell tissue has been collected, the partial vacuum in the front part can be neutralized by deforming the piston by means of a pawl and consequently admitting air to the cylinder.

In the case of the known aspiration instrument the partial vacuum is created beforehand, so that the person performing the biopsy, called the doctor below, can then concentrate fully on the collection of the cell material. The known aspiration instrument in this case can
5 be operated with one hand, with the result that the collection of the cell material can be accurate and the doctor can advantageously use the other hand for, for example, fixing the tissue to be examined during the operation. Moreover, the working distance from the hand to the tissue to be punctured is short, with the result that the
10 operation can be performed with a high degree of accuracy.

However, the known aspiration instrument is designed for a single use. In practice, this means that the aspiration instrument has been found too expensive for human applications, and certainly for
15 veterinary applications. Due to the relatively high wastage of material involved in single use, the known aspiration instrument is also environmentally unfriendly. Besides, in various countries there are different procedures for the collection of cell material, which in practice can mean that it is compulsory to collect cell material twice
20 from one patient. This even further emphasizes the abovementioned drawbacks of the known aspiration instrument.

The object of the present invention is to provide an aspiration instrument of the type mentioned at the beginning which does not have the abovementioned disadvantages, while at the same time the
abovementioned advantages are retained.

25 To this end, the aspiration instrument according to the invention is characterized in that the plunger, the guide means for the plunger, the pre-compression means, the locking means and the unlocking means therefor are combined to form a unit to which the cylinder is detachably connected, while the unit is made of sterilizable material.

30 An aspiration instrument in which a cylinder can be detachably connected at one side is known from US Patent 4,967,762, which describes a system of a hypodermic syringe and a cylinder in which a needle can be fixed. The cylinder is for detachably fastening on the front of the hypodermic syringe. This system has the disadvantage that
35 it cannot be operated with one hand. For the collection of cell material, the needle is introduced into the tissue to be punctured, following which the plunger has to be pulled backwards in order to create sufficient partial vacuum in the cylinder to be able to

aspirate the cell material. This is an ergonomically paradoxical manoeuvre. During the withdrawal of the piston from a hypodermic syringe a tensed-up position of the hand occurs, which makes sensitive and controlled guidance of the needle of the hypodermic syringe difficult. Besides, this movement requires the use of two hands, with the result that the tissue to be punctured cannot be fixed in the correct position. All this increases the chance of unrepresentative cell material also being collected. The reliability of the diagnosis in regard to the collected material is consequently adversely affected.

In one advantageous embodiment, the unit and the cylinder are connected to each other by means of a bayonet fastening. This embodiment makes it possible to fasten the cylinder and the unit of the aspiration instrument according to the invention to each other in a simple and secure manner.

In another advantageous embodiment, the unit and the cylinder are connected to each other by means of a threaded fastening. This embodiment is an alternative possibility for fastening the cylinder quickly and securely to the unit.

In a further advantageous embodiment, the volume determined in the cylinder between the first and the second position is at least approximately equal to 2.5 cc. In this embodiment an optimum is advantageously found between the maximum partial vacuum to be created in the cylinder, on the one hand, and the length of the aspiration instrument, on the other hand. It has been found in practice that with a greater volume of cylinder the partial vacuum which it is possible to create therein increases only marginally. In addition, at this length the aspiration instrument according to the invention can be easily operated with one hand; the working distance between the hand and the tissue to be punctured permits accurate handling of the aspiration instrument.

In another embodiment of the aspiration instrument according to the invention, at least the guide means are made of metal, in particular of aluminium. In this embodiment the guide means can be sterilized after use, following which they are ready for reuse. In addition, the metal makes a detailed machining of the aspiration instrument possible during the manufacturing process. The metal is preferably an aluminium alloy. In this embodiment the unit is easy to

handle, which increases the accuracy with which the cell material can be collected. At the same time, this means that the unit is of durable construction, which results in a cost saving in the long term.

In a further advantageous embodiment, the piston is fastened
5 detachably on a piston holder connected to the remaining part of the plunger. In this embodiment, it is possible to fasten the previously sterilized piston quickly and securely on the piston holder in such a way that in use no leakage of cell material from the cylinder occurs.

The present invention also relates to a cylinder which at one end
10 has means for fastening a hypodermic needle and at the other end is provided with means for connecting the cylinder to the unit according to the invention.

The piston is preferably fastened in the cylinder with the aid of
locking means. This design makes it possible to connect both the
15 cylinder and the piston simultaneously to the unit.

The present invention will be illustrated further below with reference to the appended drawings, in which

Figure 1 shows a sectional view of an aspiration instrument
according to the present invention, in which the plunger is situated
20 in the first position;

Figure 2 shows a sectional view of the aspiration instrument
according to the invention, in which the plunger is situated in the
second position.

Figure 1 shows a sectional view of aspiration instrument 1
25 according to the present invention. Aspiration instrument 1 comprises a unit 2 to which a cylinder 3 is detachably connected. Unit 2 comprises a plunger 6 which is movable with the aid of guide means 4 from a first to a second position in the direction of cylinder 3. In
Figure 1 plunger 6 is shown in the first position. One end 7 of the
30 plunger is in the form of a piston holder and is provided with a piston 8. During the forward movement of the plunger 6, piston 8 moves through the cylinder 3 from the first to a second position.

In Figure 2 aspiration instrument 1 is likewise shown in
longitudinal section, in this case plunger 6 being situated in the
35 second position. It can be seen clearly that piston 8 is now situated in the second position, in the front of the cylinder 3.

Unit 2 is also provided with locking means for locking plunger 6
in the second position. To this end, in the preferred embodiment

shown, plunger 6 comprises opening 9, which is suitable for accommodating lug 10. The locking means can be unlocked with the aid of unlocking means. In the preferred embodiment shown, both the locking means and the unlocking means are fitted on a lever 11, which is fastened to unit 2.

During the depression of plunger 6, pre-compression means 17 for moving plunger 6 back to the first position are pre-compressed, which means are situated in the unit 2. In the preferred embodiment shown, the pre-compression means 17 consist of a coil spring which is fitted around the plunger 6, and at one side rests against wall 20 of the unit 2 and at the other side rests against a supporting part 19 in plunger 6. Unlocking the locking means with the aid of unlocking lever 11 causes plunger 6 to move from the second to the first position.

In the preferred embodiment shown, the guide means are in the form of a tube 4. The tube 4 is shut off at its distal end by a wall 20, in which an opening is made, in order to allow through the plunger 6. Plunger 6 is also provided with a part 18, which is preferably detachably fastened thereto, and whose external dimensions correspond to the internal dimensions of tube 4. In the preferred embodiment shown, the part 18 comprises a supporting part 19 against which coil spring 17 rests.

Lever 11 is preferably attached to unit 2 by means of the mechanism shown, in which pawl 12 of unit 2 can be accommodated in a corresponding opening on lever 11. Lever 11 is provided with spring means 13, preferably in the form of a leaf spring, which ensure that the lever 11 springs back into its top position. Lever 11 is provided at the front side with a preferably movable pawl 14, which can be accommodated in opening 15 on cylinder 3. The way in which the above works will be explained below.

Cylinder 3 is preferably made of a plastic material, for example polycarbonate. Cylinder 3 is provided at its distal end with means for fastening hypodermic needle 5, which means preferably comprise a Luer lock. At the proximal end the cylinder 3 is provided with fastening means for detachable connection thereof to the unit 2. These fastening means, which are situated partially on the unit 2, can comprise, for example, a bayonet closure or a screw closure (not shown). In this way cylinder 3 can be connected detachably to the unit 2 and forms the disposable part of the aspiration instrument 1 according to the

present invention. Cylinder 3 is sterilized and supplied in a sterile pack, and is manufactured in accordance with the guidelines for medical aids of the particular countries where the product is to be sold under the CE standard. The internal volume of the cylinder 3, which is determined by the first and second position of piston 8, is approximately 2.5 cc in the preferred embodiment. This makes the creation of a theoretical partial vacuum or underpressure of approx. 900 mbar possible according to the law of Boyle - Gay Lussac. It is known from practice that increasing this volume in fact contributes little more to the increase in the partial vacuum. However, the extension of cylinder 3, and thus of aspiration instrument 1, increases the working distance between the tissue to be punctured and the hand of the doctor. With the choice of this volume, the length of the aspiration instrument is therefore determined in the optimum way.

The unit 2 is made of a material which is suitable for sterilization. Unit 2, which comprises the mechanism, can thus be reused many times, which increases the environmental friendliness of aspiration instrument 1. Unit 2 is preferably made partially or fully of metal. In a second preferred embodiment, at least the guide means are made of metal. The metal is preferably an aluminium alloy, which makes unit 2 light and durable. Unit 2 can be, for example, cast or obtained by mechanical working.

Piston 8 and piston holder 7 are formed in such a way that piston 8 can be clamped detachably on piston holder 7. Piston 8 and piston holder 7 are formed in such a way here that leakage of the aspirated cell material from cylinder 3 is prevented. After attachment, piston 8 is clamped at the sides by cylinder 3. Piston 8 is preferably made of a flexible material, for example plastic.

The coil spring 17 is preferably made of stainless steel material and has a spring constant which is adapted to the work which is necessary for travelling the distance from the second position to the first position. The chosen spring constant depends partly on the friction resistance encountered during the distance to be travelled. This friction resistance is partly determined by two components: the piston 8 and the inside wall of cylinder 3. In order to reduce the resistance, piston 8 is preferably made of a self-lubricating plastic, such as that in known hypodermic syringes. In the preferred embodiment discussed, the spring constant is 0.385 N/mm, with a tolerance of

± 0.1. It will be clear that this value is given only by way of indication, and is in no way intended as a restriction.

The aspiration instrument according to the present invention can be operated as follows:

5 First of all, the sterilized cylinder 3, which is supplied separately, is removed from the pack. Piston 8 is preferably already fitted in a locked position in cylinder 3. For this purpose, piston 8 contains locking means, such as a thickened part in the outside wall thereof which fits into a recess in the inside wall of cylinder 3. The
10 thickened part is preferably designed in such a way that in use it will break off on movement of piston 8 from the first to the second position in cylinder 3. Cylinder 3 and piston 8 are then connected to unit 2 together in one movement with the aid of fastening means, preferably a bayonet closure, whereby piston 8 is fastened on piston
15 holder 7.

As an alternative to the method of operation described above, a sterilized piston 8, delivered separately, can be removed from its pack and fastened on piston holder 7. The cylinder 3, which has also been sterilized, is then removed from its pack and connected by means
20 of the fastening means to the unit 2 of the aspiration instrument 1. Finally, in both cases hypodermic needle 5 is fitted on cylinder 3. The aspiration instrument 1 is now fully ready for use.

The doctor who is going to collect the cell material must first of all depress the plunger 6, in which case counterpressure can be
25 given by the index and middle finger by placing these fingers behind wings 16 of unit 2. The doctor in this case has one hand available for firmly fixing the tissue location to be punctured and then with the other hand introducing needle 5 of the aspiration instrument 1 into the tissue to be examined.

30 After the point of the needle 5 has been introduced into the suspect tissue, the partial vacuum can be activated by pressing on the front of the unlocking lever 11. For this, only a very subtle downward movement of the index finger is required. In the course of this, lug
10 is lifted out of opening 9 of unit 2, with the result that the pre-
35 compression means for moving plunger 6 back to the first position are activated. During this backward movement, a partial vacuum is created in cylinder 3, with the result that cell material is sucked up through needle 5. In the course of this, the doctor has to perform a number of

to and fro movements with needle 5 through the suspect tissue. When sufficient cell material has been collected, the partial vacuum in cylinder 3 must first be removed before needle 5 is withdrawn from the patient's skin. This is necessary in order to prevent cell material 5 which is not relevant from also being aspirated during the withdrawal of needle 5. The partial vacuum can also be removed by exerting pressure on lever construction 11. Pawl 14 will in this case deform piston 8 by way of opening 15 in cylinder 3, in which case the pressure in cylinder 3 is neutralized. For this purpose, lever 11 must 10 be held in its lowest position for a few seconds. Needle 5 can then be withdrawn from the tissue, and the collected cell material is available for examination.

Aspiration instrument 1 is held like a pen during the entire operation. The short working distance between the manipulating hand 15 and the tissue to be punctured contributes to the optimum sensitivity of the aspiration instrument according to the invention.

Cylinder 3 and piston 8 can be thrown away together with needle 5 after use, while the unit 2 can be sterilized or autoclaved. In the preferred embodiment shown, unit 2 is simple to dismantle prior to 20 sterilization. By in fact dividing the aspiration instrument into two parts, a small part as the disposable part and the larger part as the non-disposable part, wastage of material is largely prevented. The relatively most expensive part and most material-consuming part can be reused many times.

Claims

1. Aspiration instrument (1) for cell biopsy purposes, comprising:
a cylinder (3) which at the distal end is provided with means for
5 fastening a hypodermic needle (5),
a plunger (6) whose distal end is in the form of a piston (8),
which piston (8) is movable in the cylinder (3) between a first
position and a second position,
guide means (4) for guiding the plunger (6),
10 pre-compression means (17) by means of which the plunger (6) is
pre-compressable in the direction of the first position, which pre-
compression means (17) are activated when the plunger (6) is moved
from the first to the second position,
locking means (9, 10) by means of which the plunger (6) can be
15 locked in the second position,
means for unlocking the locking means, in order to make the
plunger (6) move from the second to the first position under the
influence of the pre-compression means (17),
characterized in that,
20 the plunger (6), the guide means (4) for the plunger (6), the
pre-compression means (17), the locking means and the unlocking means
therefor are combined to form a unit (2) to which the cylinder (3) is
detachably connected, while the unit (2) is made of sterilizable
material.
- 25 2. Aspiration instrument according to Claim 1, characterized in that
the unit (2) and the cylinder (3) are connected to each other by means
of a bayonet fastening.
3. Aspiration instrument according to Claim 1, characterized in that
the unit (2) and the cylinder (3) are connected to each other by means
30 of a threaded fastening.
4. Aspiration instrument according to one of the preceding claims,
characterized in that the guide means (4) are in the form of a tube
which is shut off at the distal end by a wall (20), in which an
opening is made, in order to allow through the plunger (6), and in
35 that the plunger is also provided with a part (18) whose external
dimensions correspond to the internal dimensions of the tube, which
part (18) is guided in the tube.
5. Aspiration instrument according to Claim 4, characterized in that

the pre-compression means (17) consist of a coil spring which is disposed around the plunger (6), and at one side rests against the abovementioned wall (20) and at the other side rests against a supporting part (19) in the part (18) of the plunger (6).

- 5 6. Aspiration instrument according to Claim 5, characterized in that in the first position the piston (8) rests against the wall (20).
7. Aspiration instrument according to one of the preceding claims, characterized in that at least the guide means (4) are made of metal, in particular of an aluminium alloy.
- 10 8. Aspiration instrument according to one of the preceding claims, characterized in that the volume determined in the cylinder (3) between the first and the second position is at least approximately equal to 2.5 cc.
9. Aspiration instrument according to one of the preceding claims, characterized in that the piston (8) is fastened detachably on a
15 piston holder (7) connected to the remaining part of the plunger (6).
10. Cylinder having at one end means for fastening a hypodermic needle (5), and at the other end provided with means for connecting the cylinder (3) to the unit (2) as defined in one of the preceding
20 claims.
11. Cylinder according to Claim 10, in which the piston (8) is fastened with the aid of locking means.

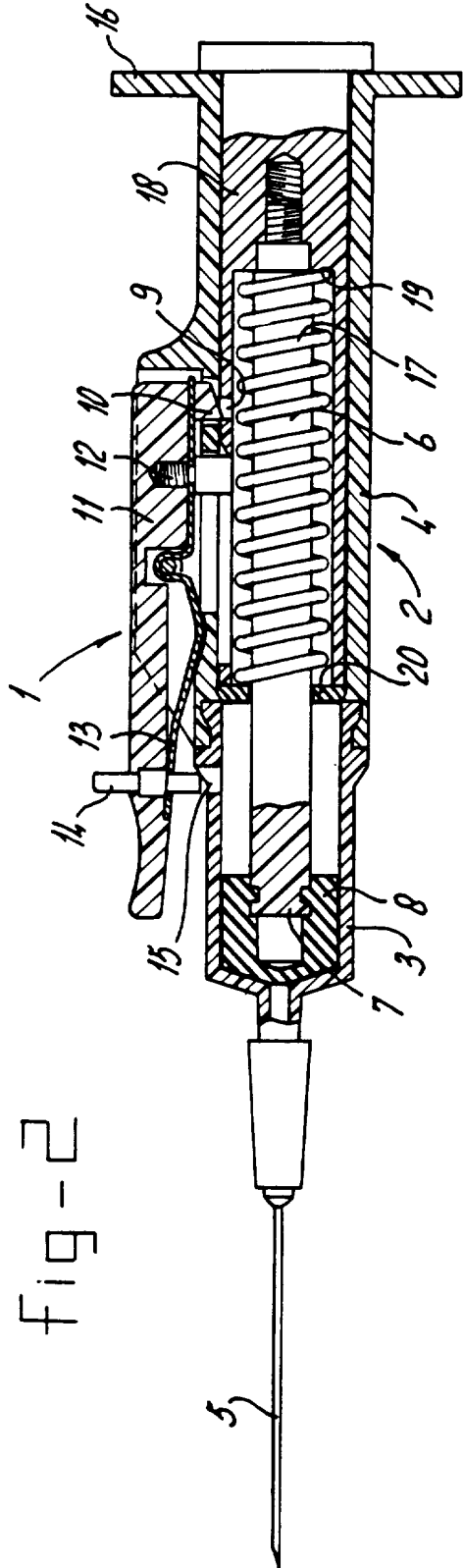
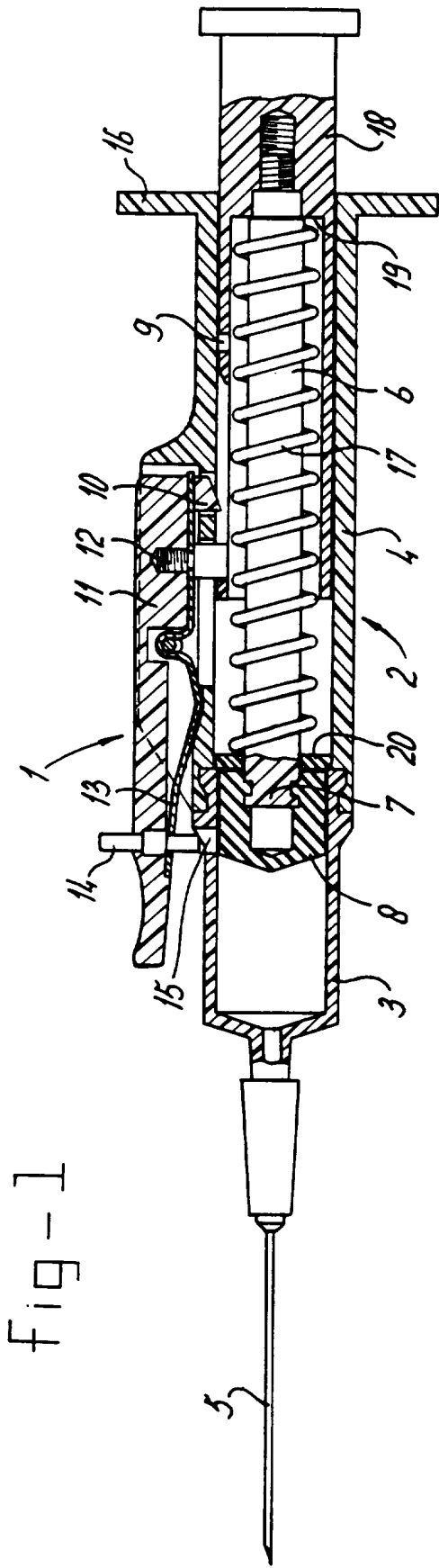

INTERNATIONAL SEARCH REPORT

Int. Patent Application No
PCT/NL 96/00111

A. CLASSIFICATION OF SUBJECT MATTER
IPC 6 A61B10/00

According to International Patent Classification (IPC) or to both national classification and IPC

B. FIELDS SEARCHED

Minimum documentation searched (classification system followed by classification symbols)
IPC 6 A61B

Documentation searched other than minimum documentation to the extent that such documents are included in the fields searched

Electronic data base consulted during the international search (name of data base and, where practical, search terms used)

C. DOCUMENTS CONSIDERED TO BE RELEVANT

Category *	Citation of document, with indication, where appropriate, of the relevant passages	Relevant to claim No.
A	FR,A,1 111 814 (SOCIETE A RESPONSABILITE LIMITEE DRAPIER) 5 March 1956 see the whole document ---	1,11
A	US,A,4 641 663 (JUNN) 10 February 1987 see column 2, line 16 - line 34 see column 5, line 5 - line 25; figures 5-10 -----	1,4,5

Further documents are listed in the continuation of box C.

Patent family members are listed in annex.

* Special categories of cited documents :

- *A* document defining the general state of the art which is not considered to be of particular relevance
- *E* earlier document but published on or after the international filing date
- *L* document which may throw doubts on priority claim(s) or which is cited to establish the publication date of another citation or other special reason (as specified)
- *O* document referring to an oral disclosure, use, exhibition or other means
- *P* document published prior to the international filing date but later than the priority date claimed

- *T* later document published after the international filing date or priority date and not in conflict with the application but cited to understand the principle or theory underlying the invention
- *X* document of particular relevance; the claimed invention cannot be considered novel or cannot be considered to involve an inventive step when the document is taken alone
- *Y* document of particular relevance; the claimed invention cannot be considered to involve an inventive step when the document is combined with one or more other such documents, such combination being obvious to a person skilled in the art.
- *Z* document member of the same patent family

Date of the actual completion of the international search

14 June 1996

Date of mailing of the international search report

19.06.96

Name and mailing address of the ISA

European Patent Office, P.B. 5818 Patentlaan 2
NL - 2280 HV Rijswijk
Tel. (+ 31-70) 340-2040, Tx. 31 651 epo nl,
Fax: (+ 31-70) 340-3016

Authorized officer

Calamida, G

INTERNATIONAL SEARCH REPORT

Int. onal Application No PCT/NL 96/00111

Patent document cited in search report	Publication date	Patent family member(s)	Publication date
FR-A-1111814	05-03-56	NONE	
US-A-4641663	10-02-87	US-A- 4766886	30-08-88