

(19) World Intellectual Property Organization  
International Bureau



(43) International Publication Date  
7 May 2009 (07.05.2009)

PCT

(10) International Publication Number  
**WO 2009/058830 A1**

(51) International Patent Classification:  
A61B 17/20 (2006.01)

(74) Agent: NEUGEBOREN, Craig; Neugeboren O'Dowd PC, 1227 Spruce Street, Suite 200, Boulder, Colorado 80302 (US).

(21) International Application Number:  
PCT/US2008/081540

(81) Designated States (unless otherwise indicated, for every kind of national protection available): AE, AG, AL, AM, AO, AT, AU, AZ, BA, BB, BG, BH, BR, BW, BY, BZ, CA, CH, CN, CO, CR, CU, CZ, DE, DK, DM, DO, DZ, EC, EE, EG, ES, FI, GB, GD, GE, GH, GM, GT, HN, HR, HU, ID, IL, IN, IS, JP, KE, KG, KM, KN, KP, KR, KZ, LA, LC, LK, LR, LS, LT, LU, LY, MA, MD, ME, MG, MK, MN, MW, MX, MY, MZ, NA, NG, NI, NO, NZ, OM, PG, PH, PL, PT, RO, RS, RU, SC, SD, SE, SG, SK, SL, SM, ST, SV, SY, TJ, TM, TN, TR, TT, TZ, UA, UG, US, UZ, VC, VN, ZA, ZM, ZW.

(22) International Filing Date: 29 October 2008 (29.10.2008)

(25) Filing Language: English

(26) Publication Language: English

(30) Priority Data:  
60/983,877 30 October 2007 (30.10.2007) US  
60/989,874 23 November 2007 (23.11.2007) US  
12/259,907 28 October 2008 (28.10.2008) US

(71) Applicant (for all designated States except US): HIPCO, INC. [US/US]; 1417 Vail Valley Drive, Vail, Colorado 81657 (US).

(84) Designated States (unless otherwise indicated, for every kind of regional protection available): ARIPO (BW, GH, GM, KE, LS, MW, MZ, NA, SD, SL, SZ, TZ, UG, ZM, ZW), Eurasian (AM, AZ, BY, KG, KZ, MD, RU, TJ, TM), European (AT, BE, BG, CH, CY, CZ, DE, DK, EE, ES, FI, FR, GB, GR, HR, HU, IE, IS, IT, LT, LU, LV, MC, MT, NL, NO, PL, PT, RO, SE, SI, SK, TR), OAPI (BF, BJ, CF, CG, CI, CM, GA, GN, GQ, GW, ML, MR, NE, SN, TD, TG).

(72) Inventors; and

(75) Inventors/Applicants (for US only): PHILIPPON, Marc [CA/US]; 181 W. Meadow Drive, Suite 400, Vail, Colorado 81657 (US). BOMBARD, David [US/US]; 10 Singletree Road, Edwards, Colorado 81632 (US). EGAN, John Michael [US/US]; 1474 Commodore Way, Hollywood, Florida 33019 (US).

Published:  
— with international search report

(54) Title: DEVICE AND METHOD FOR HIP DISTENTION AND ACCESS

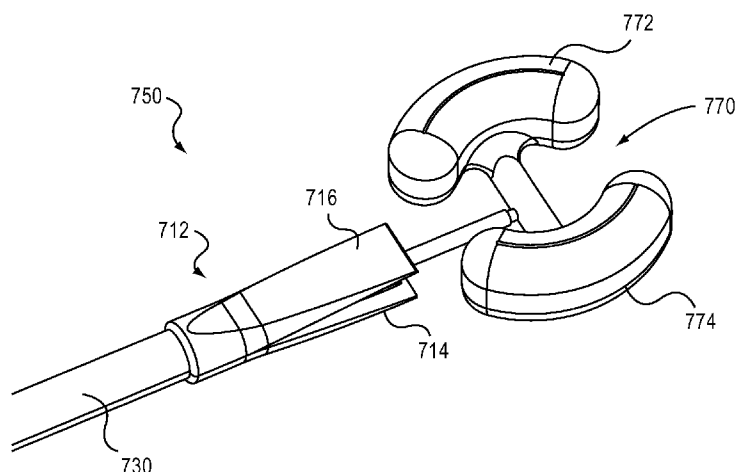

Fig. 15

(57) Abstract: A device for accessing and distending a joint comprises a distraction structure having a generally tapered distal portion adapted to penetrate a tissue region and create an access space within a joint. The distraction structure also includes a lumen extending from a proximal surface to a distal portion. The device further includes a distention structure deployable through the lumen and adapted to exert a force between a first joint surface and a second joint surface and create a working space. The distention structure may, in some embodiments, include an elongate member having a proximal end, a distal end, and a lumen extending along at least a portion of the length of the elongate member, a first expandable region deployable from a first substantially collapsed position to a second substantially expanded position, the first expandable region adapted to exert a force between the first joint surface from the second joint surface.

WO 2009/058830 A1

**DEVICE AND METHOD FOR HIP DISTENTION AND ACCESS****PRIORITY AND CROSS REFERENCE TO RELATED APPLICATIONS**

[0001] This application claims the benefit of Provisional U.S. Patent Application No. 60/983,877 filed on October 30, 2007, Provisional U.S. Patent Application No. 60/989,874 filed on November 23, 2007 and U.S. Patent Application No. 12/259,907 filed on October 28, 2008. The details of these Application Nos. 60/983,877, 60/989,874, and 12/259,907 are incorporated by reference into the present application in their entirety and for all proper purposes.

**FIELD OF THE INVENTION**

[0002] Aspects of the present invention relate to devices and methods for the atraumatic distention of the head of the femur away from the acetabulum in order to create a working space for a variety of endoscopic hip surgeries. Other aspects relate to devices and methods for distending soft tissue structures from the neck of the femur. More particularly, aspects of the present invention pertain to devices and methods that utilize balloons, or other atraumatic means and/or devices, to distend the head of the femur away from the acetabulum in order to create a working space for a variety of endoscopic hip surgeries

**BACKGROUND AND DESCRIPTION**

[0003] Endoscopic hip surgeries such as joint arthroscopy, debridement, joint flushing and joint smoothing are relatively common procedures for the general treatment of hip pathology that leads to painful joints. An important step in these procedures is to assure that the joint surfaces are properly accessible by the surgeon and that good visualization is provided. Current methods for accessing the joint

surfaces involve the use of a mechanical rack and pinion system that attaches to the foot of the patient to mechanically pull the femur away from the acetabulum (traction). This type of manual dislocation of the femoral head from the socket is extremely traumatic and invasive to both the patient and the surgical room staff that is tasked with maneuvering the patient's leg. This method of distention is also only marginally effective and the possible side effects to the surgery include numbness, nerve damage, impotence, deep vein thrombosis and pulmonary embolus associated with damage to the veins. Additionally, the leg in traction is not easily manipulated to allow visualization of the articular cartilage areas. Therefore, a less traumatic and less damaging method is needed to create a working space between the femur and acetabulum in order to perform one of a variety of hip procedures. Additionally, because soft tissue structures located within the hip joint contribute to the difficulty of working in this area, a device is needed to manage or otherwise move these tissue structures from the hip capsule.

#### **SUMMARY OF THE INVENTION**

[0004] In accordance with one aspect, a device for distending a first body tissue from a second body tissue comprises a flexible elongate member, the flexible elongate member including first and second lumens extending at least a portion of the length of the elongate member, a first distention member coupled to the first lumen and deployable from a substantially collapsed position to a substantially expanded position, and a second distention member coupled to the second lumen and deployable from a substantially collapsed position to a substantially expanded position.

[0005] In accordance with another aspect, a device for accessing and distending a joint comprises a distraction structure having a generally tapered distal portion adapted to penetrate a tissue region and create an access space within a joint. The device includes a lumen extending from a proximal surface to a distal portion, a distention structure deployable through the lumen and adapted to exert a force between a first joint surface and a second joint surface and create a working space.

[0006] In accordance with another aspect, a method of accessing a space within a joint including at least a partial seal formed by one or more tissue structures comprises accessing the joint between a first joint surface and a second joint surface to create a first working space, inserting a distraction device into the first working space, using the distraction device to break the partial seal formed by the one or more tissue structures, at least partially internally distracting the first joint surface from the second joint surface, advancing the distraction device to a first location within the joint, advancing a first distention device proximate to the first location, using the distention device to distend the first joint surface from the second joint surface at a point proximate the first location to create a second working space, and performing a surgical procedure proximate the second working space.

[0007] Various other aspects will become apparent as disclosed herein and as would be known to those of skill in the art.

#### **BRIEF DESCRIPTION OF THE DRAWINGS**

[0008] Various objects and advantages and a more complete understanding of the present invention are apparent and more readily appreciated by reference to the following Detailed Description and to the appended claims when taken in conjunction with the accompanying Drawings, wherein:

[0009] Figure 1 is a cross section of a human hip joint showing details of where the femoral head engages with the socket of the hip

[0010] Figure 2 is a further embodiment of Figure 1;

[0011] Figures 3A-3F show various embodiments of a device constructed in accordance with various aspects of the present invention;

[0012] Figures 4A and 4B are cross sections of another embodiment of a distention device constructed according to various aspects of the present invention;

[0013] Figure 5 shows another embodiment of a device constructed in accordance with aspects of the present invention;

[0014] Figures 6 and 7 show further embodiments of devices constructed in accordance with aspects of the present invention;

[0015] Figures 8A and 8B show another embodiment of a device constructed in accordance with aspects of the present invention;

[0016] Figures 9A and 9B show another embodiment of a device constructed in accordance with aspects of the present invention;

[0017] Figures 10 and 11 show one of the general techniques used to repair and/or reconstruct the acetabular labrum;

[0018] Figure 12A- 12F illustrate one method of using a device constructed in accordance with aspects of the present invention;

[0019] Figure 13 is one embodiment of a surgical tool constructed in accordance with aspects of the present invention;

[0020] Figure 14 is another embodiment of a surgical tool constructed in accordance with aspects of the present invention;

[0021] Figure 15 is a further embodiment of a surgical tool constructed in accordance with aspects of the present invention;

[0022] Figure 16 is a general representation of a hip joint and how devices constructed in accordance with aspects of the present invention may be utilized;

[0023] Figure 17 is another embodiment of a device constructed in accordance with aspects of the present invention; and

[0024] Figures 18 and 19 are further embodiments of a device constructed in accordance with aspects of the present invention.

### **DETAILED DESCRIPTION**

[0025] With reference to Figure 1, a generalized cross section of a human hip joint 100 is shown. For simplicity, only the major regions of the hip anatomy are indicated in Figure 1 so that aspects of a device constructed in accordance with the present invention may be described. Shown in Figure 1 are the femur 102 and the femoral head 104. In a healthy anatomy, the femoral head 104 engages snugly with the acetabulum 106, and more particularly with the inner concave surface 106a of the acetabulum. Where the head of the femur 104 meets the acetabulum 106 is referred to generally as the hip joint. For many endoscopic hip surgeries, the region where the femoral head engages with the acetabulum is the area where most operative procedures take place and where reconstructive or repair techniques are applied to the patient. It is therefore important to gain good access and visualization to this region, and in particular the joint surfaces, during a surgical procedure.

[0026] In accordance with one general aspect of the present invention, a series of inflatable or expandable distention structures are placed between the femoral head 104 and the concave portion 106a of the acetabulum 106. As shown in Figure 1, these structures are referred to as reference numbers 118, 120, and 122 and are shown in their un-expanded or deflated positions. Both the femoral head 104 and the concave surface 106a of the acetabulum 106 include articular cartilage 112 that aids in allowing the hip joint to move freely and pain free. The overall anatomy of the hip joint 100 also includes ligaments and joint capsules 108 and 114 as well as a synovial membrane 116. Acetabular labrum 110 is a ring of cartilage that surrounds the acetabulum and functions to deepen the acetabulum, making it more difficult for the head of the femur 104 to slip out of place. Aspects of the present invention provide access for surgical techniques such as repair and/or reconstruction of the acetabular labrum.

[0027] While various inflatable devices and techniques are known to gain access to the region between the femoral head 104 and the acetabular surface 106a, none have addressed the particular surgical access problems that exist in hip joint anatomy. Figure 2 illustrates the general aspects of the inflatable and/or expandable distention structures 118, 120, and 122 in their expanded and/or inflated position, showing the region or zone of work 130 created proximate the acetabular labrum 110, and the general working space 132 and 134 created between the acetabular surface 106a and the femoral head 104.

[0028] Various embodiments of the distention structures 118, 120, and 122 and various embodiments of devices that provide access to and delivery of the structures 118, 120, and 122 are described in further detail below.

[0029] With continuing reference to Figure 2, the distention structures 118, 120, and 122 are shown in their expanded and/or inflated positions and, as such, are exerting a force  $F$  between the acetabular surface 106a and the femoral head 104. This force thus distends the acetabular surface 106a away from the femoral head 104 creating zone of work 130 and potentially additional working spaces 132 and 134, depending on the number and size of distention structures being used. Zone of work 130 and working space 134 is sometimes referred to as the Peripheral Compartment. It is the space in the joint capsule around the neck and head of the femur that can be accessed with the head of the femur in the acetabulum. This area may extend all the way around to the inferior part of the femur. Working space 134 is sometimes referred to as the Central Compartment and represents the virtual space that exists when the femoral head is moved away from the acetabulum. Depending on the surgical procedure being employed, the particular pathology of the hip joint being addressed by the surgery, and the specific access needs of the surgeon during the procedure, various numbers, sizes, and shapes of distention structures 118, 120, and 122 may be employed.

[0030] As will become apparent throughout this description, the number, size and shape of the distention structures will vary greatly depending on the particular application. By showing three such distention structures in Figures 1 and 2, or by showing any particular number and/or size of distention structures in connection with other figures or embodiments, there is no intention to limit the scope of the invention to these particular embodiments. In contrast, it is envisioned that a wide range of sizes, shapes, materials, and configurations of distention structures, along with various applicators or other delivery devices are contemplated herein. Because the surface of the femoral head 104 and the acetabular surface 106a, are complex geometries, and



the pathology of the particular patient might involve any portion of these surfaces or regions, it is important that a surgeon have at his disposal a wide variety of mechanisms to gain proper access and visualization to these areas. Among other aspects, it is these problems that the prior art fails to adequately address.

[0031] Turning to Figures 3A – 3F, various embodiments of distention structures constructed in accordance with aspects of the present invention are shown. While the examples shown in Figures 3A – 3F are representative, they are by no means meant to be exhaustive of the different shapes and configurations that are contemplated by aspects of the present invention. Because of the variation allowed in modern materials, it is contemplated that any shape and configuration of distention structure may be constructed to work in conjunction with aspects of the present invention.

[0032] Figure 3A shows a distention structure 210 with a generally circular perimeter surface 206. The image of Figure 3A is shown from a top down view. While distention structure 210 is shown with a generally circular perimeter, it is contemplated that the cross section of structure 210 may be one of several shapes. For instance, the cross section may also be generally circular, giving structure 210 an overall generally spherical shape. As another example, the cross section may be rectangular, giving structure 210 a generally tubular shape. Portion 202 is a generally flexible tube that includes one or more functions such as insertion/removal of the structure 210, inflation/deflation, steering of the structure 210 through a body cavity, delivery of fluid or drugs, suction, and/or expansion/contraction of the structure 210. As such, portion 202 may include one or more internal lumens, actuation mechanisms, such as cables and guide wires, or steering devices.

[0033] Figure 3B shows another embodiment of a distention structure 220 that includes a generally kidney shaped perimeter with generally convex surface 222 and generally concave surface 224. Distention structure 220 may be used in situations where distention is indicated in the same general area 225 as where hip joint pathology is located and where treatment is indicated by the surgeon.

[0034] Figure 3C shows another embodiment of a distention structure 230 that includes a generally horseshoe shaped perimeter with a first lobed portion 234 and a second lobed portion 232 which together define an interior area 236. Distention structure 230 may be used in situations where distention is indicated in the same general area 236 as where hip joint pathology is located and where treatment is indicated by the surgeon.

[0035] Figure 3D shows another embodiment of a distention structure 240 that includes a generally kidney shaped perimeter with generally convex surface 242 and generally concave surface 244. Region 246 represents an adjustable area of distention structure 240 that may be deployed in a controllable manner in order to increase or decrease the overall size and area that distention is maintained within the joint capsule. Distention structure 240 may be used in situations where distention and hip joint pathology is indicated proximate the areas 245 and 247.

[0036] Figures 3E and 3F show further embodiments of distention structures 250 and 260 that are generally similar in overall shape to distention structure 230 described above except that portion 202 is coupled to the distention device at different locations in order to change the overall area of treatment that is exposed to a surgeon when the device is deployed. For example in Figure 3E, portion 202 is coupled to a first lobe 252 of the distention device 250. When deployed, the distention device 250 exposes a

region 256 to the surgeon which is in-line with the delivery of portion 202. In Figure 3F, access and inflation portion 202 is coupled to the proximal edge of distention structure 260 and exposes a region 266 that is somewhat distal with the delivery of portion 202 and intermediate to lobes 264 and 262 of distention device 260.

[0037] As mentioned above, the cross sections of the distention devices described above may be one of several shapes such as circular, square, trapezoidal, toroidal, spheroid, oblong, conical, tubular, and/or cylindrical and may therefore define various working space shapes within the hip joint. Benefits of such variety in the shape of the distention devices enable a surgeon to customize the access and visualization he has to the diseased area of the hip joint.

[0038] Turning now to Figures 4A and 4B, a device 300 is shown that is adapted to deliver one or more distention devices to a location within the anatomy, more particularly, to a location within the hip joint, more particularly to a location between the acetabulum and the femoral head. Device 300 includes a proximal end 304 that is in some embodiments coupled to an actuator or other type of control mechanism adapted to deliver air or fluid to one or more distention devices 310 and 320. In addition, proximal end 304 is preferably coupled to one or more types of control mechanisms that allow a surgeon or other user to advance and otherwise control the location and movement of the device 300. Those of skill in the art will appreciate the extent of the devices that may couple with proximal end 304.

[0039] Device 300 is generally tubular in design and includes one or more cannulas adapted to actuate the distention structures 310 and 320. In Figures 4A and 4B, two distention structures 310 and 320 are shown, and thus two cannulas 306 and 308 are shown within a sheath 305 of the device 300. Cannula 306 delivers fluid, air or some

other actuation material to distention device 310 while cannula 308 delivers fluid, air or some other actuation material to distention device 320. Based on the specific surgical requirements or user preferences, one or more of distention devices 310 and 320 may be actuated in unison or individually. In addition, any number of distention devices and associated tubular lumens may be utilized to provide a wide range of customizable structures and formats to account for varying anatomy and surgical procedures.

[0040] In the embodiment of Figures 4A and 4B, the distention devices 310 and 320 are depicted as inflatable devices formed from one or more types of surgical quality rubber, silicone or another appropriate flexible material known to those of skill in the art. In some embodiments, the distention devices are formed from a non-elastic material so that the distention force applied by the devices can be controlled and high enough to separate the femoral head from the acetabulum.

[0041] Distention devices 310 and 320 are also preferably formed from material able to withstand sufficient pressure in order to apply enough force to the opposing sides of the hip joint to separate them during surgery. In practice, this pressure ranges from about 50 N to about 700 N. Thus, the distention devices 310 and 320 are in some embodiments made from a material that will not expand beyond a certain size. Distention devices 310 and 320 may be sized to take this into account while providing the desired amount of working space within the hip joint.

[0042] A problem that arises often in hip surgeries is the ability of the surgeon to gain initial access to the hip joint, and in particular access to the space between the acetabular surface and the femoral head. Ligament and other tissue structures such as the acetabular labrum, capsular ligaments, and other tissue structures serve to keep a

very snug fit between the acetabulum and the femoral head. Thus, it is often difficult to initially penetrate this region prior to gaining access to the surgical site within the hip joint itself. Prior art devices and systems do not attempt to deal with this problem in any meaningful way.

[0043] Figure 5 illustrates another aspect of a device constructed in accordance with the present invention designed to address this particular problem. In Figure 5, the acetabulum 402 and femoral head 404 of a hip joint 400 are initially accessed by a device 420. Device 420 includes a proximal end 422 that projects or extends back to a surgeon or other user and is coupled to a control or other handle device as known in the art. Distal end 423 of device 420 includes structure 424 for penetrating, breaking or otherwise releasing the seal that often exists between acetabulum 402 and femoral head 404. Structure 424, in some embodiments, includes a tapered, wedge or other knife-shaped leading edge in order to aid in displacing the capsular material, acetabular labrum or other tissue that holds the hip joint in place.

[0044] Figures 6 and 7 show several alternative embodiments of the device 420 and more particularly the distal structure 424. In Figure 6, structure 450 includes a tapered and generally knife-shaped leading edge 452 with a generally wedge shaped profile 456. Top surface 454 is preferably smooth to enable a low friction advancement through the structure of the hip joint. In some embodiments, the surface of structure 450 may be coated with an appropriate material or other substance to promote easy entry into the hip joint and acetabular space. Proximal face 458 includes structure for engagement with a cannula or activation structure 460 that allows for the advancement or retraction of the structure 454. Activation structure

460 may be an elongate flexible tube or may be rigid to facilitate the penetration into the acetabular region.

[0045] In Figure 7, structure 470 includes a pair of generally tapered and knife-shaped leading edges 474 and 475 that are similar in format to those in Figure 6. The structure 470 of Figure 7 however, includes a mid-line region 476 accessible by a port 480 formed into proximal end 478 of the structure 470. Port 480 allows additional devices to be inserted through structure 470 without needing to remove or maneuver around structure 470. For example, after structure 470 is placed within a hip joint, and has given the surgeon access to the region defined by the intersection of the acetabular surface and the femoral head, a distention device such as those described in conjunction with Figure 4 above, may be inserted through the port 480 along mid-line region 476 and to the portion of the hip joint that requires distention.

[0046] Figures 8A and 8B show another embodiment of such a device as it would be used and deployed during a surgical procedure such as a femoral head reconstruction or acetabular labrum repair procedure. A device 500 includes a generally wedge or knife-shaped leading surface 504 and has running through its structure a lumen 502. Catheter 506 is connected with lumen 502 and is adapted to deliver a distention device through the lumen to a region requiring distention and/or surgical treatment. Lumen 502 may also be adapted to deliver a fluid delivery catheter or other pressurized fluid delivery system in order to aid in breaking the seal formed by the hip joint capsule. Distal region 508 of the catheter 506 includes a distal tip 510 that includes one form of distention device 512. In Figure 8B, distention device 512 is an inflatable or otherwise expandable balloon constructed in a way to distend the acetabular surface away from the femoral head when moved into its expanded

position. After deployment, the distention balloon 512 can be deflated and retracted through the lumen 502. As discussed in the embodiments below, device 500 can be removed during a procedure to increase visualization and then re-introduced to remove the distention device 512.

[0047] Turning now to Figures 9A and 9B, a dual balloon distention device 550 is shown. A proximal end 552 of the device 550 is connected by known means to an actuator or other control mechanism that provides for positional control of the device 550 as well as the ability to provide inflation gas or liquid to each of the distally located inflatable structures 562 and 564. In one embodiment, the distention device 550 is a dual lumen elongate structure with substantially parallel lumens 554 and 556 running along its length. At some medial point along the length of the structure 550, the lumens split into two and create a wishbone shaped device with first distal end 558 and second distal end 560. Inflatable distention portion 562 runs along a portion of the length of lumen 554 and inflatable distention portion 564 runs along another portion of the length of lumen 556. The overall dimension of each of the inflatable portions 562 and 564 may be determined by the procedures involved or the particular anatomy being repaired during operation and it is contemplated that the size, shape and overall orientation of the distention balloon is customizable by the user or surgeon. While it is contemplated that the entire device 550 may be introduced as a whole, each of the lumens 554 and 556 may be independently maneuvered into the anatomy during surgery in order to place them specifically. Figure 9A shown the inflatable distention portions 562 and 564 in a deflated position, while Figure 9B shows the inflatable distention portions in a substantially inflated position and in a generally horseshoe-like shape similar to the distention device represented in, e.g. Figure 3C.

[0048] The distention device 550 may be utilized alone or in combination with one of the devices represented in connection with Figures 5-8, such that the hip joint is separated and then distended in a single procedure.

[0049] While hip pain can be caused by multiple pathologies, FemoroAcetabular Impingement (FAI) and injuries to the acetabular labrum are the most common pathologic findings identified at the time of hip arthroscopy. FAI can cause labral injury and early osteoarthritis. Causes of labral tears include trauma, FAI, capsular laxity, dysplasia, and degeneration. Various surgical techniques have been used to restore function of the hip joint and labrum. Suture anchor repair is one preferred and well-known method of labrum repair. The goal of arthroscopic treatment of a torn labrum and FAI is to relieve pain by eliminating the unstable flap tear and bony morphology that causes hip discomfort. The goals of these treatments are to maintain the function of the hip joint and decrease the development of premature osteoarthritis. Aspects of devices and methods in accordance with the present invention are useful in combination with these surgical labrum repair techniques.

[0050] As an example of a surgical technique that would benefit from the use of devices and methods disclosed herein, Figures 10 and 11 illustrate a generalized view of the portion of the acetabular labrum that may become detached and in need of repair. These figures also illustrate in general terms, the process for repairing the labrum through a known suture anchor technique. As mentioned above, the acetabular labrum 602 is a ring of cartilage that surrounds the socket of the hip joint 600 (i.e. the acetabulum). When the acetabular labrum 602 becomes detached from the bony portion of the acetabulum 600, repair or reconstruction is needed. As shown in Figures 10 and 11, one known method of repair involves providing at least a pair of



anchors 606 and 608 via a surgical tool 604 and then using sutures 610 to reattach the labrum 602 to the bone 600.

[0051] Repair of the acetabular labrum, or some other hip repair or reconstruction surgery such as FAI decompression, removal of loose bodies, labral debridement, microfracture chondroplasty, osteoplasty, total hip replacement, hip resurfacing, tendon release, etc. either as done in the past or as disclosed herein, may be accomplished in combination with one or more of the distention devices and/or techniques described herein. Figures 12A – 12F illustrate one embodiment of a device constructed in accordance with aspects of the present invention used in connection with an acetabular labrum repair. Referring to Figures 12A – 12F, Acetabulum 620 and femoral head 625 are initially distended or distracted via a surgical tool 630. In general terms, tool 630 includes an elongate member 634 that directs and/or actuates distal end 632. Distal end 632 may be formatted and designed according to any of the embodiments disclosed herein. For example, distal end may incorporate an inflatable distention structure and/or an acetabular distracting structure such as the wedge shaped embodiment disclosed in conjunction with Figures 5-8. In either case, the distal end 632 advances through the space between the acetabulum 620 and the femoral head to a point where distention of the hip joint is desired, such as depicted in Figure 12C. In one embodiment, distal end 632 is advanced by pushing or otherwise manually manipulating the distal end through the hip joint. Once located within the hip joint, a distention device is activated, e.g. inflated, to a point where appropriate distention is accomplished. In the example of Figure 12C, a balloon 636 or other inflatable portion is positioned and elongate member 634 is removed from the distended hip joint. At this point, repair to the acetabular labrum can be accomplished through any technique known or as disclosed herein such as depicted at 646. For

treatment of FAI, once the impinging lesion has been visualized, a long motorized burr may be introduced in to the working space to perform an osteoplasty to resect any impinging bone. A 'rim trimming' procedure may also be performed in which the labrum is detached, the rim of the acetabulum is resected with a motorized burr, and the labrum reattached with anchors. If the labrum is too badly damaged for repair, a labral reconstruction procedure may be performed. In this procedure, a graft of tissue from the Iliopsoas or Iliotibial tendon or other appropriate tissue is used to reconstruct the labrum with the use of suture and bone anchors.

[0052] Turning now to Figure 13, one embodiment of a device 700 adapted to gain access to the space between the acetabulum and femoral head and/or distend the hip joint is shown. The device 700 generally includes a handle assembly 702 and a trigger or other actuation structure 704 as many known arthroscopic surgical instrument include. An elongate tubular structure 710 includes a proximal end 711 and a distal end 712. A portion 706 of the proximal end 711 allows rotation of the entire elongate member 710. Tactile grip portion 708 provides improved mobility and maneuverability of the elongate member 710 to a user. The distal end 712 of the elongate member includes a wedge shaped structure with opposing jaw portions 714 and 716. The elongate structure 710 includes at least one lumen through which a tubular distention device 750 may extend through. At a distal end of the distention device 750 is a distention balloon or other distention structure 760. In the embodiment of Figure 13, the distention structure 760 is shown as an inflatable balloon in its generally collapsed position. As depicted by the arrows in Figure 13, both the elongate member 710 of the device 700 as well as the tubular distention device 750 may be rotatable such that the distal end 712 and the distention structure 760 may be aligned in any position relative to the hip joint as a whole, the

acetabulum, the femoral head or any of the other structures within the hip joint anatomy. As an alternative, the entire device 700 may be rotated in order to specifically position the distention structure 760 or the distal end 712.

[0053] Figure 14 shows an isolated view of the overall distention device 750 including a proximal end 752 which in one embodiment is coupled with an actuation device such as a compressed air or hydraulic pump system that acts to inflate or otherwise expand the distention structure 760 located at the distal end of the distention device 750. A flexible tube or other elongate member 756 provides the ability to extend or otherwise position the distention structure 760 at any desired point within the hip joint. Distention device 750 may be rotated by a user so that the orientation of distention structure 760 may be moved dynamically by a user.

[0054] Figure 15 shows an alternate embodiment of a distention structure 770 that includes a pair of distention lobes 772 and 774. As described previously, the shape, size, number, and orientation of the distention structure may be modified according to the particular procedure and/or anatomy being operated on. In any case, the distention structure is capable of being collapsed within a sheath or other containment structure so that it may be deployed through the tool 750.

[0055] Figure 16 shows a general representation of a hip joint 800 including pelvis 806, acetabular surface 802, femoral head 805 and femur 804. In use, the device 750 utilizes the wedge shaped distal structure 712 to first break the seal between the acetabulum and femoral head. After this seal is broken, distention and/or repair to the anatomy can take place as described above.

[0056] One or more distention structures may be used in connection with devices and methods in accordance with aspects of the present invention. For example, a first

balloon might be placed near the Ligamentum Teres Femoris (the ligament near the head of the femur). A second, possibly smaller distention structure is placed superior to the first in order to move the head of the femur inferiorly. Alternatively, a single distention structure with multiple expandable chambers may also be utilized. The shape of the chambers are preferably configured to the specific anatomy as is shown in the attached figures and drawings. In some embodiments the distention structures are inflatable and/or expandable balloons.

[0057] These balloons and/or chambers are then inflated (e.g. with saline or air) in various configurations to position the head of the femur relative to the Acetabulum in order to achieve the required and/or desired surgical access. In still other embodiments, a third balloon could be placed near the neck of the femur to create further working space by distending the ligaments and joint capsule. This could also be a single chamber of a multi-chamber balloon versus a completely separate balloon. This balloon could be combined with an endoscope for visualization.

[0058] In accordance with other aspects, devices and methods are disclosed that utilize balloons, or other atraumatic means and/or devices, to distend soft tissues surrounding the femur away from the bony structure in order to create a working space for a variety of endoscopic hip surgeries, many of which were described previously. Because current methods pump fluid directly into the joint in order to move these tissues, and because the capsule is cut during the surgical procedure, it can not hold the fluid pressure. It therefore collapses and interferes with visualization and the surgical instruments. Currently there is no effective means of moving these tissues to gain better access and working space. Embodiments of the present

invention allow easier access and visualization to the proximal femur during arthroscopic hip surgery.

[0059] During many endoscopic hip procedures, the joint capsule and other soft tissue structures occasionally get in the way of the endoscope and other instruments, obstructing the visual and working field. In accordance with aspects of the present invention, a balloon, or other structure, is placed partially around the femoral neck at the distal attachment of the joint capsule, near the 'zona orbicularis', to act as a tent or other enclosure to keep loose tissue free from the working area.

[0060] In one embodiment, the device consist of three main elements:

[0061] 1) A space creating element (in some embodiments this is a balloon or other inflatable or expandable structure). This structure could be made of various materials, including polyurethane, Nylon, PVC, and other compliant or non-compliant materials.

[0062] 2) A delivery tool used to deliver the balloon into position, release the balloon, and possibly to remove it or re-position it as required.

[0063] 3) An inflation device. This could be a standard syringe, or an off the shelf inflator that is used for angioplasty, or a specially made device. The inflation device could also be incorporated into the delivery tool or similar to the distention balloon described above.

[0064] One embodiment of a procedure performed in accordance with these aspects is as follows:

1. Establish an anterolateral and mid-lateral portal into the joint capsule using an appropriate surgical technique.
2. Introduce the delivery tool into the joint capsule

3. Insert a balloon into position with the delivery tool.
4. Remove the delivery tool.
5. Inflate the balloon with sterile saline via an inflation device.
6. Re-position the balloon if necessary.
7. Surgical procedure is performed as required (balloon may be deflated and re-inflated, re-positioned, or even removed during the procedure. The delivery tool may be used to accomplish these actions, or standard surgical tools may be used.
8. Deflate the access system, either with the inflation device, or manually punctured (e.g. scalpel, beaver blade)
9. Remove balloon, either with the Delivery tool or manually (e.g. forceps).
10. Complete procedure per standard of care (capsule closed, etc.).

[0065] The outer surface of the balloon may in some embodiments be covered with friction creating material. The entire surface of the balloon can be covered or only certain areas as appropriate. For example, a friction material (e.g. rough hook side of Velcro) on the upper surface to hold against soft tissue, while keeping the bottom surface smooth for contact to the bone and vascular structures located on the bone surface. Alternatively, the balloon material may be formed from two layers of polyurethane sheet with a layer of nylon mesh (filter material) in between. The sheets may be laminated together, held by an RF Weld around the edge or bound together by any other known or contemplated technique.

[0066] Figures 17 - 19 describe one embodiment of a delivery tool adapted to position a distention or access device as described above. Figure 17 shows the general anatomy of the hip, including femur 908 and femoral head 904 and how an access device 906 may be positioned proximate to the femoral neck and adjacent greater

trochanter 902 and in the area of zona orbicularis in order to move tissue from the field of view or surgical site.

[0067] Figure 18 illustrates one embodiment of a delivery device 900 that includes a main shaft 914 enclosing a cable 916, a plunger 918 and a cylinder 910. The cylinder 910 defines a cavity 922 that is adapted to carry a collapsed distention balloon or other distention structure. A shuttle 920 couples with the plunger 918 and when retracted by the cable 916 deploys the distention device carried in the cavity 922 when located at the desired point within the anatomy.

[0068] Figure 18 shows the device 900 in its retracted position while Figure 19 show the device in its deployed position, with cylinder 910 pulled back moving plunger 918 forward and releasing the distention device from the cavity 922

[0069] Those skilled in the art can readily recognize that numerous variations and substitutions may be made in the invention, its use and its configuration to achieve substantially the same results as achieved by the embodiments described herein. Accordingly, there is no intention to limit the invention to the disclosed exemplary forms. Many variations, modifications and alternative constructions fall within the scope and spirit of the disclosed invention.

**WHAT IS CLAIMED IS:**

1. A device for accessing and distending a joint, the joint including a first joint surface and a second joint surface, the joint substantially enclosed by a tissue region, the device comprising:
- 5 a distraction structure, comprising
- a generally tapered distal portion adapted to penetrate the tissue region and create an access space;
  - a proximal surface;
  - a lumen extending from the proximal surface to the distal
- 10 portion;
- a distention structure deployable through the lumen of the distraction structure and adapted to exert a force between the first joint surface and the second joint surface in order to separate the first joint surface from the second joint surface and create a working space.
- 15 2. The device of claim 1, wherein the first joint surface is the acetabulum and the second joint surface is a femoral head.
3. The device of claim 1, wherein the distention structure comprises:
- an elongate member having a proximal end, a distal end, and a lumen extending along at least a portion of the length of the elongate member;
- 20 a first expandable region deployable from a first substantially collapsed position to a second substantially expanded position, the first expandable region adapted to exert a force between the first joint surface from the second joint surface;



wherein the first expandable region is proximate to the distal end of the elongate member and is in fluid communication with the lumen of the elongate member.

4. The device of claim 3, wherein the distention structure further comprises:

5 a second expandable region deployable from a first substantially collapsed position to a second substantially expanded position, the second expandable region adapted to exert a force between the first joint surface from the second joint surface; and

10 wherein the second expandable region is in fluid communication with the second lumen of the elongate member.

5. The device of claim 1, wherein the distention structure is a balloon.

6. The device of claim 1, wherein the distention structure comprises a plurality of balloons deployable at different locations within the hip joint.

7. The device of claim 5, wherein the balloon, when in its expanded position, is a  
15 substantially spheroid shape.

8. The device of claim 5, wherein the balloon, when in its expanded position, is one of an ellipsoid, horseshoe, kidney, hexagonal, octagonal, or toroidal shape.

9. The device of claim 4, wherein the first and second expandable regions are aligned in a substantially parallel configuration.

20 10. The device of claim 4, wherein the first and second expandable regions are aligned in a substantially linear configuration.

11. The device of claim 4, wherein the first and second expandable regions are aligned in a substantially side by side configuration.

12. A device for distending a first body tissue from a second body tissue, comprising:
- a flexible elongate member, the flexible elongate member including first and second lumens extending at least a portion of the length of the elongate member;
  - a first distention member coupled to the first lumen and deployable from a substantially collapsed position to a substantially expanded position; and
  - a second distention member coupled to the second lumen and deployable from a substantially collapsed position to a substantially expanded position.
13. The device of claim 12, wherein the first body tissue is a proximal femur surface and wherein the second body tissue is hip joint capsule.
14. The device of claim 12, wherein the first and second body tissues are abdominal tissue.
15. The device of claim 12, wherein the first and second body tissues are located in one of the knee, elbow, ankle, hip, elbow, and shoulder.
16. The device of claim 12, wherein the first and second distention members are aligned in a substantially side by side configuration.
17. The device of claim 12, wherein the first and second distention members are aligned in a substantially linear configuration.
18. The device of claim 12, wherein the first and second distention members, while in their substantially expanded positions, are one of an ellipsoid, horseshoe, kidney, hexagonal, octagonal, or toroidal shapes.

19. The device of claim 12, wherein the first and second distention members are formed from a substantially elastic material.
20. The device of claim 12, wherein the first and second distention members are formed from a substantially inelastic material.
- 5 21. A method of accessing a space within a joint, the joint including at least a partial seal formed by one or more tissue structures, the method comprising:
- accessing the joint between a first joint surface and a second joint surface to create a first working space;
  - inserting a distraction device into the first working space;
  - 10 using the distraction device to break the partial seal formed by the one or more tissue structures;
  - at least partially internally distracting the first joint surface from the second joint surface;
  - advancing the distraction device to a first location within the joint;
  - 15 advancing a first distention device proximate to the first location;
  - using the distention device to distend the first joint surface from the second joint surface at a point proximate the first location to create a second working space; and
  - performing a surgical procedure proximate the second working space.
- 20 22. The method of claim 18, wherein the first joint surface is an acetabular surface and the second joint surface is a femoral head.
23. The method of claim 18, wherein the distraction device is removed from prior to advancing the first distention device.
24. The method of claim 18, wherein the distraction device remains in place while
- 25 the first distention device is advanced to the first location within the joint.

25. The method of claim 18, further comprising performing one of an acetabular labrum repair procedure, an acetabular resurfacing procedure, a total hip replacement procedure, and a femoral neck strengthening procedure.

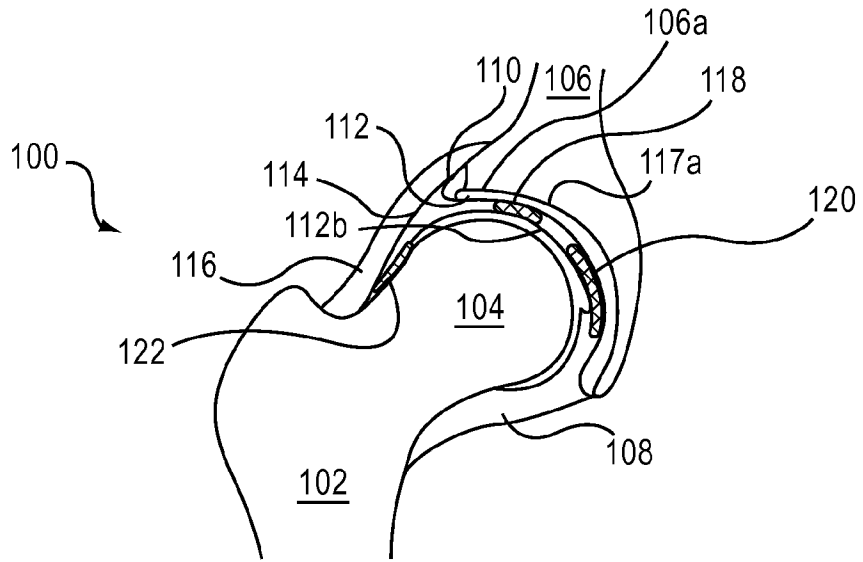

Fig.1

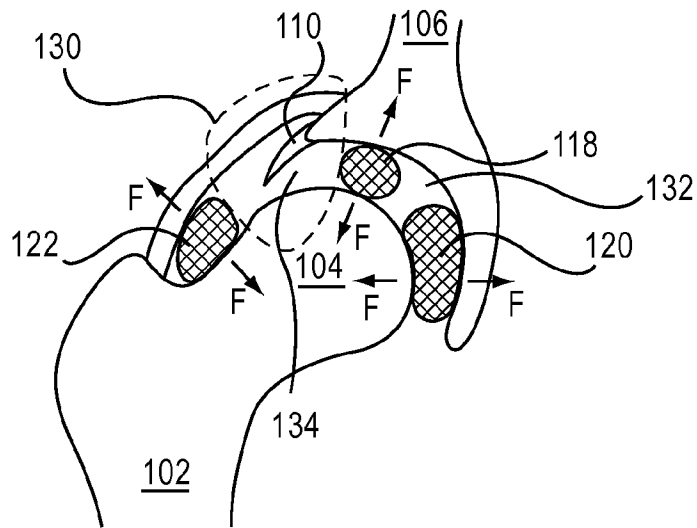

Fig.2

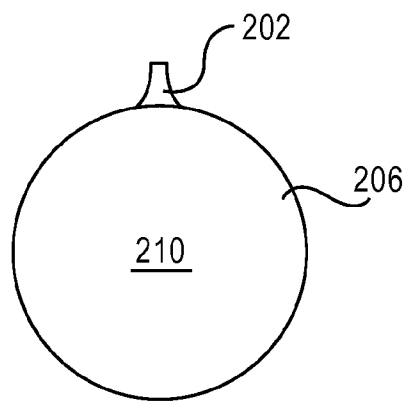

Fig.3A

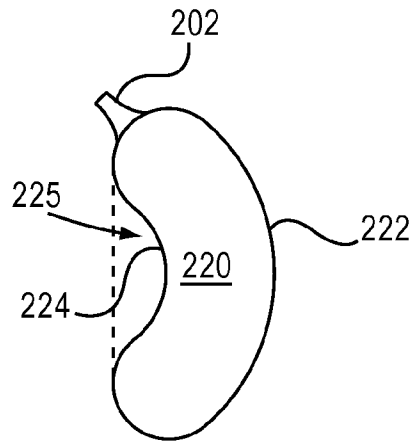

Fig.3B

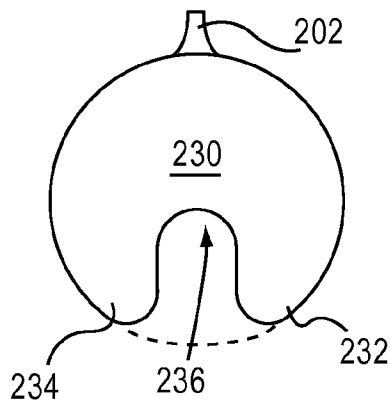

Fig.3C

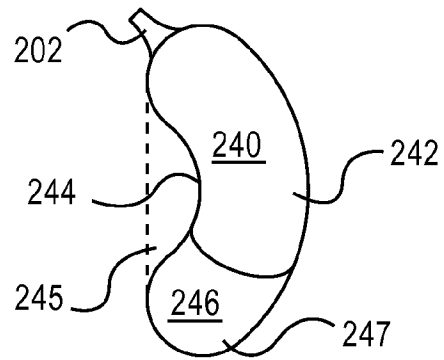

Fig.3D

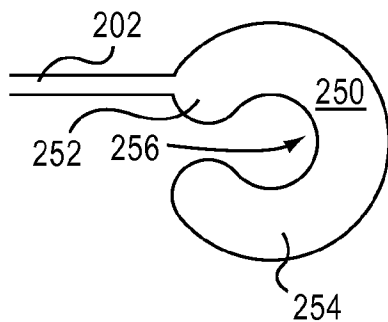

Fig.3E

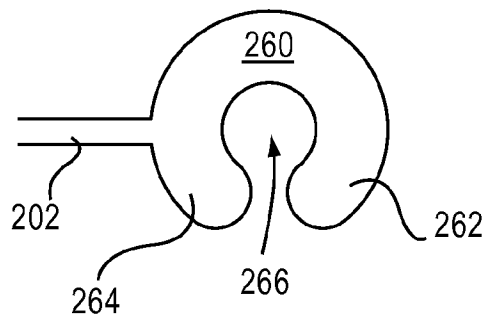

Fig.3F

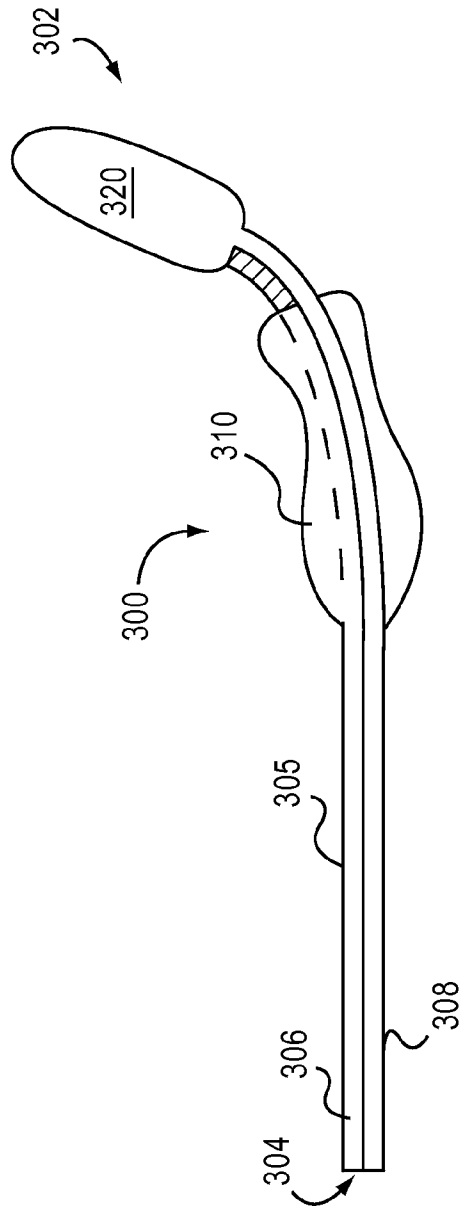

FIG. 4A

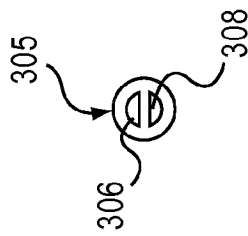
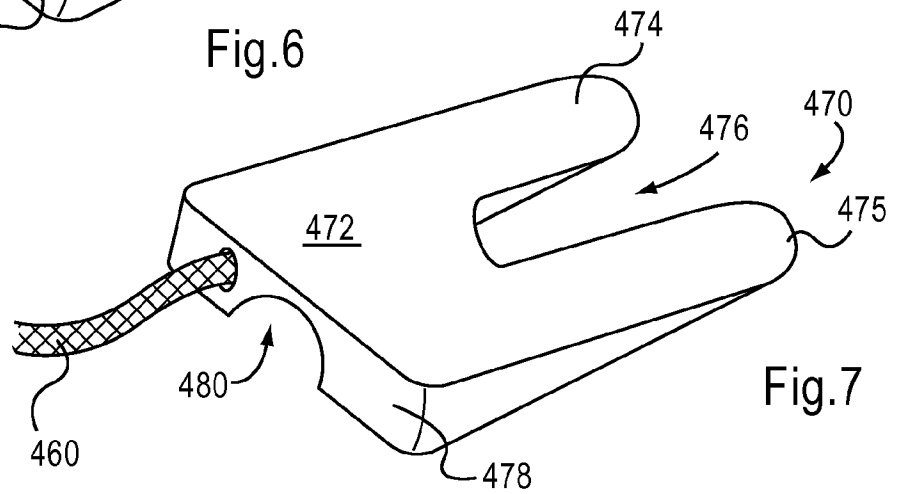
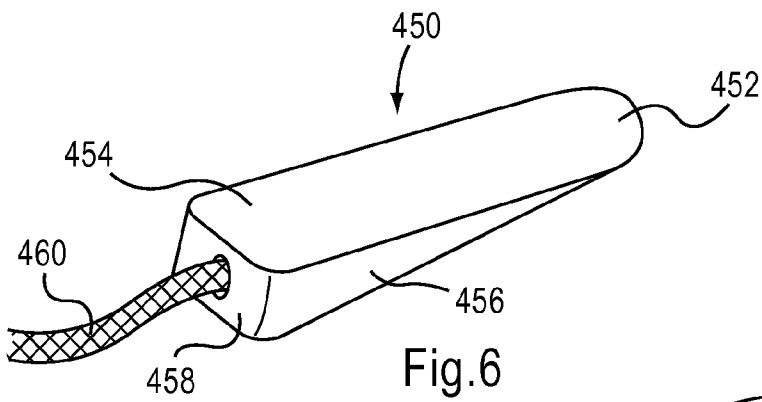
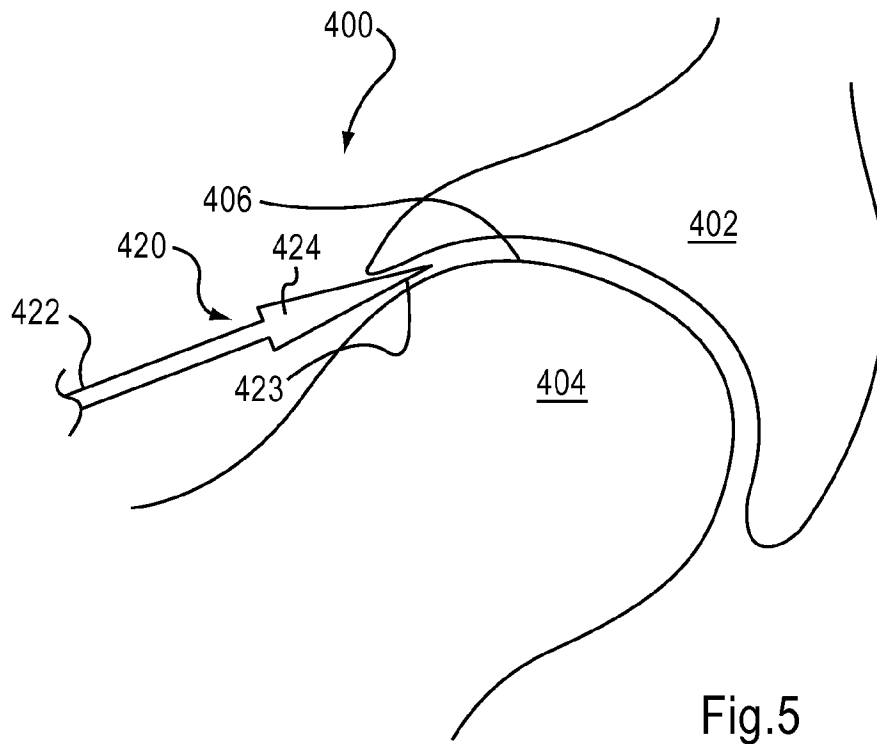
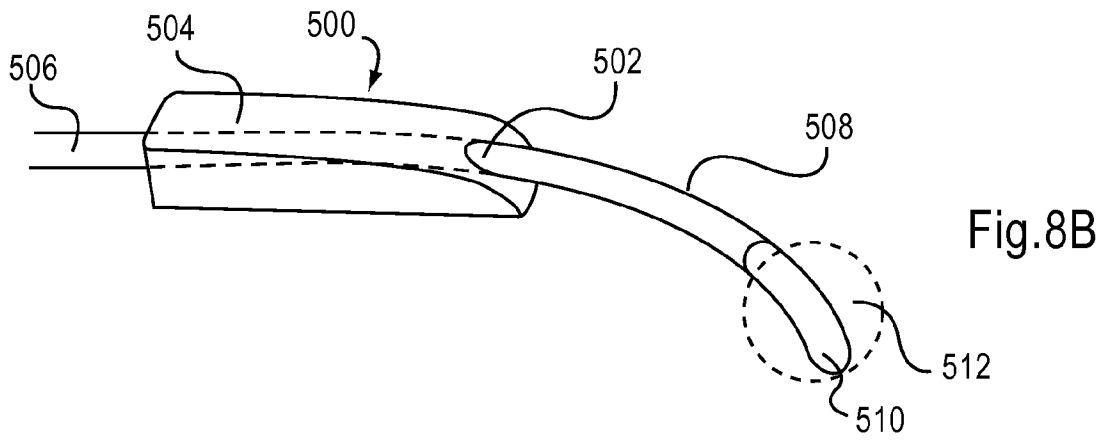
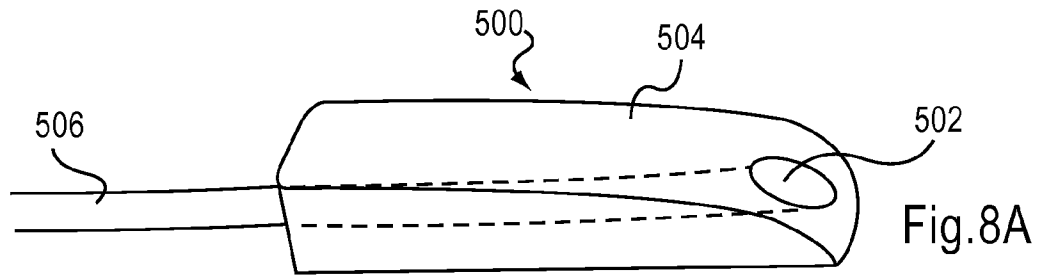

Fig. 4B

4/114







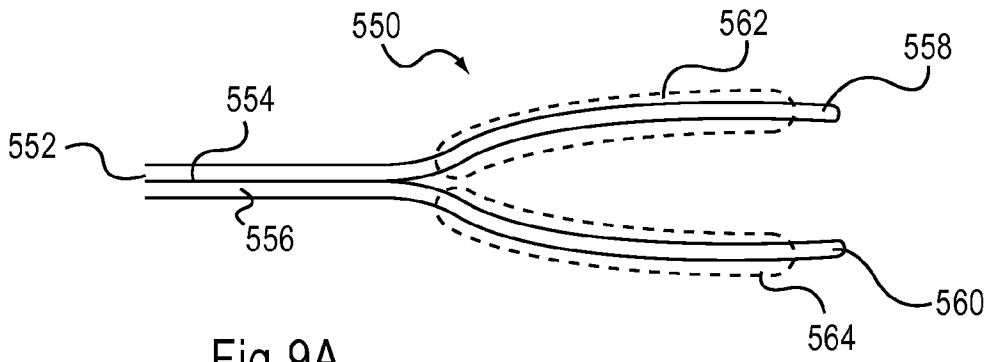

Fig.9A

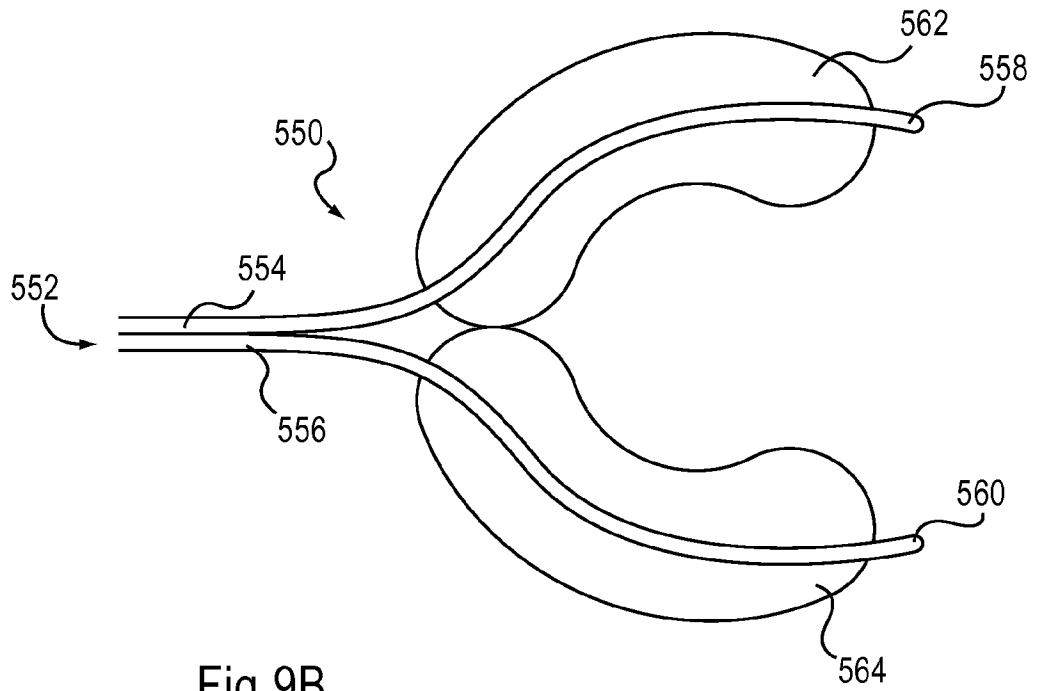

Fig.9B

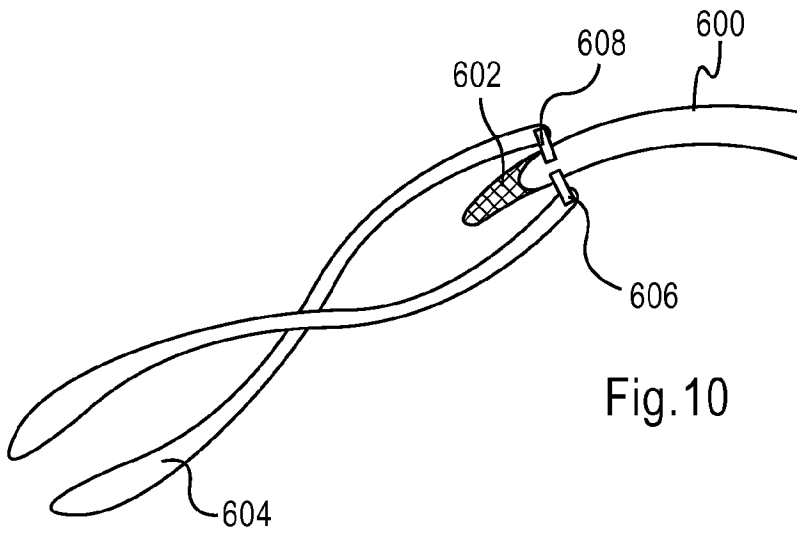

Fig. 10

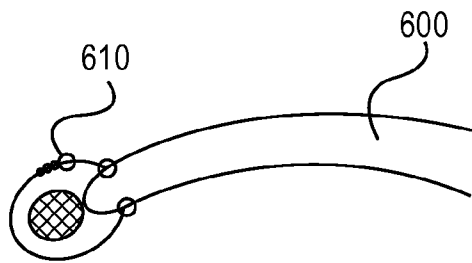

Fig. 11

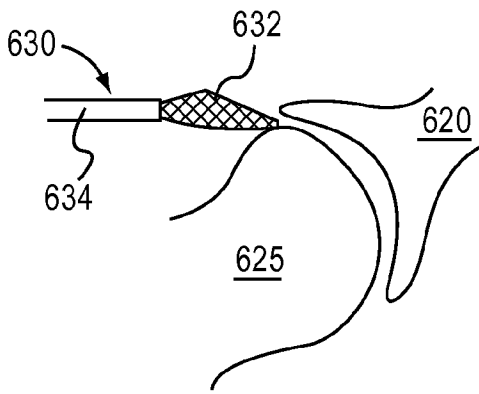

Fig. 12A

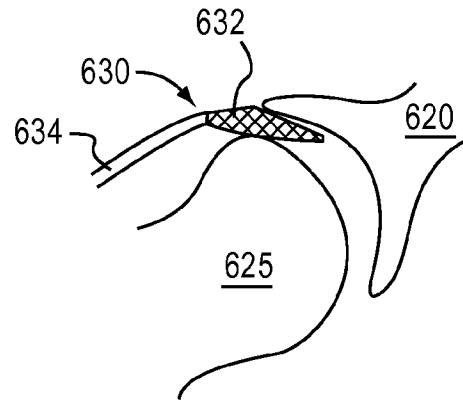

Fig. 12B

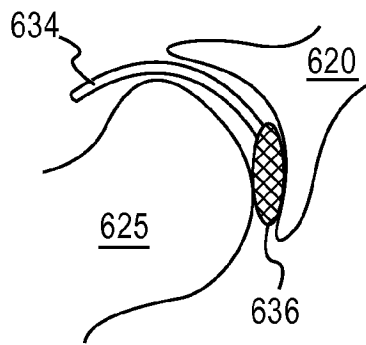

Fig. 12C

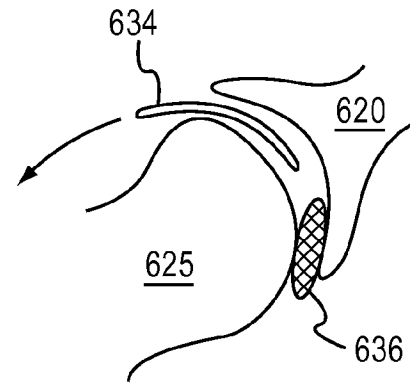

Fig. 12D

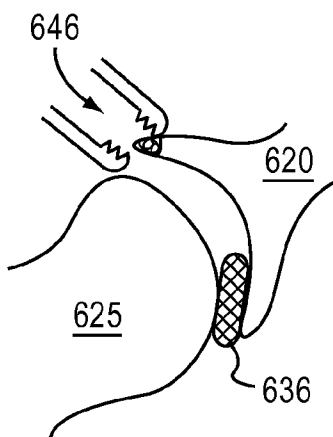

Fig. 12E

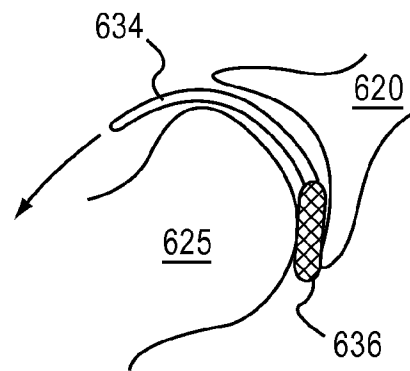

Fig. 12F

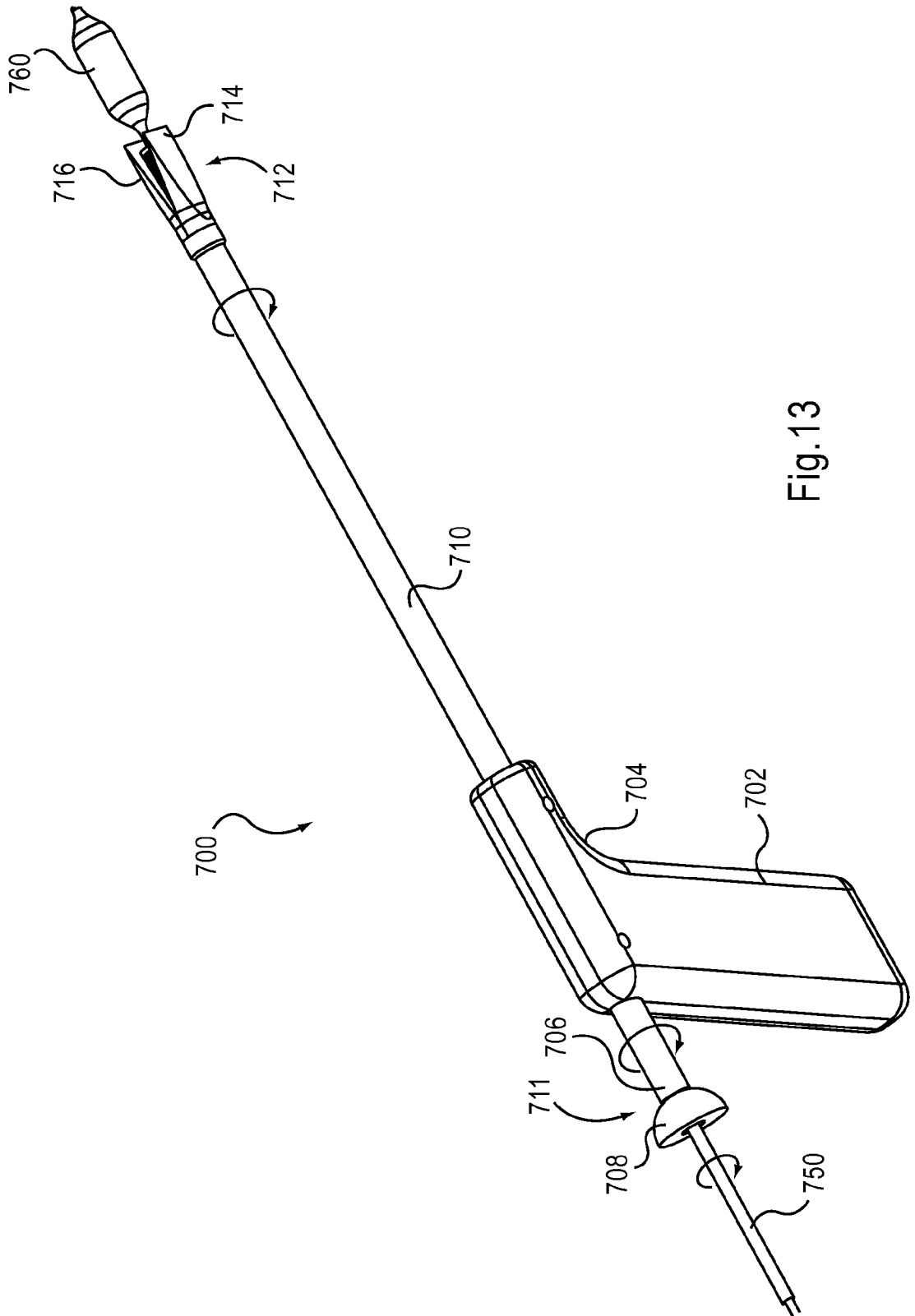

Fig. 13

10/14

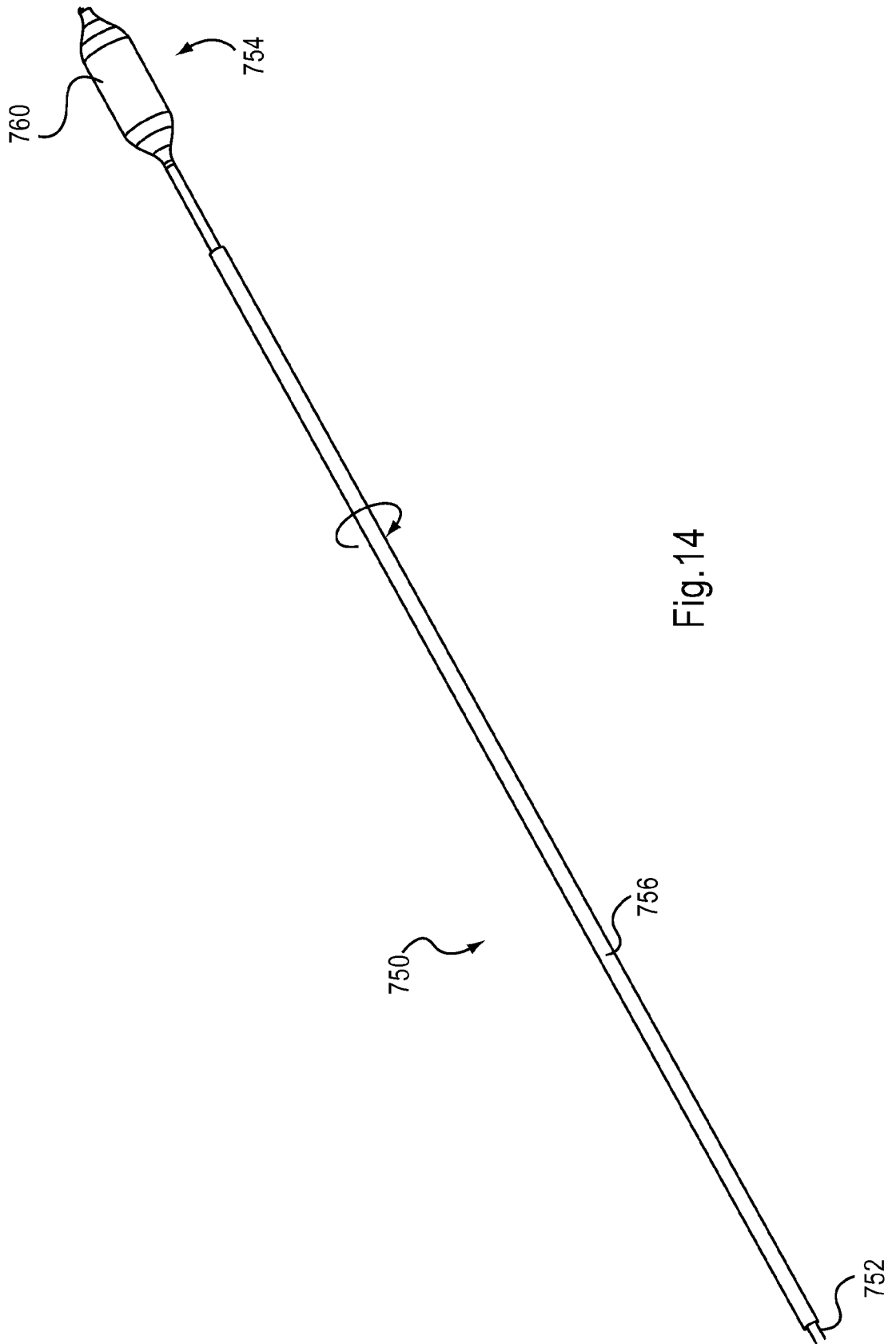

Fig. 14

12/14

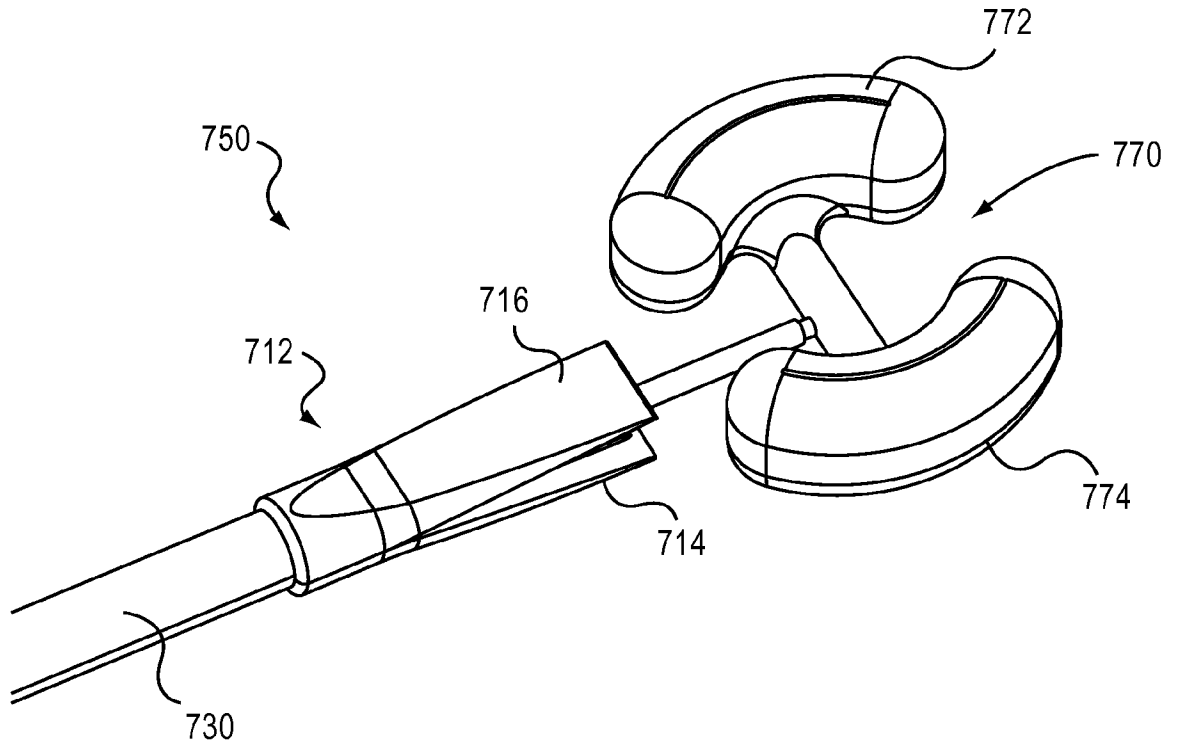

Fig.15

12/14

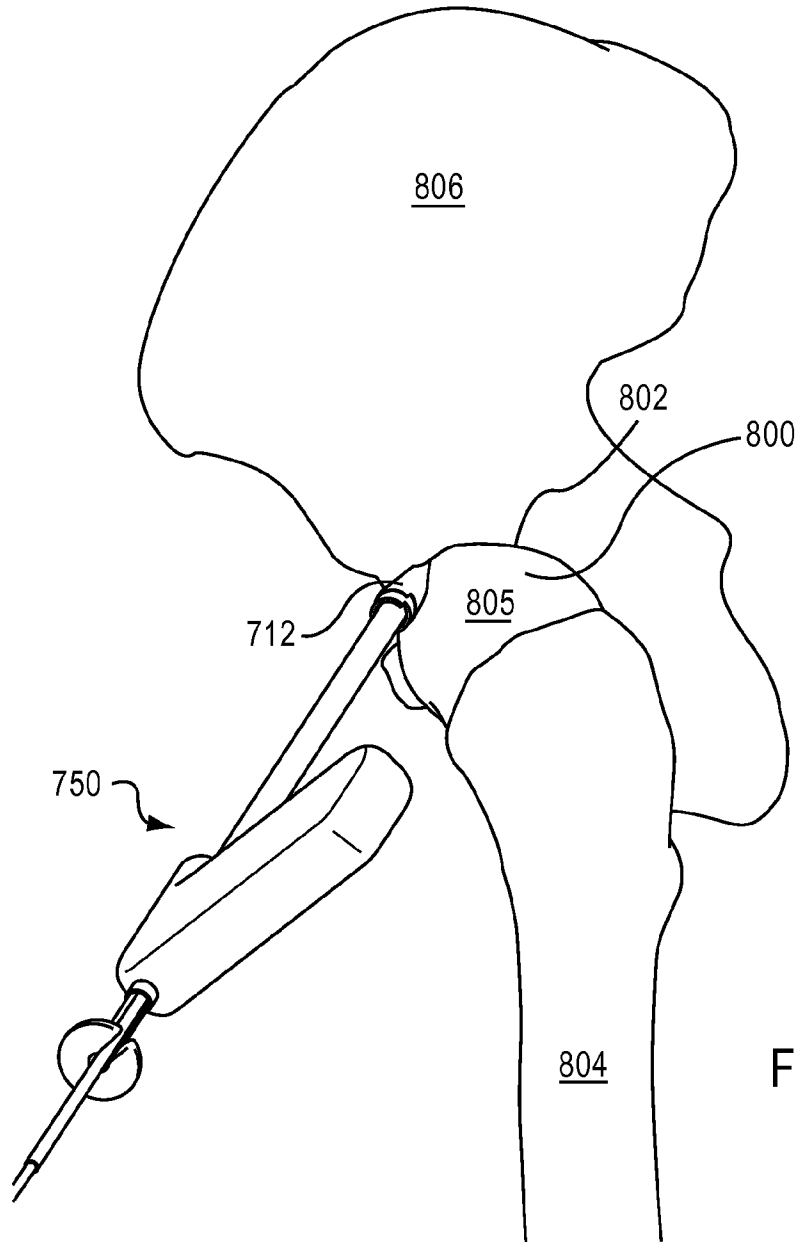

FIG.16



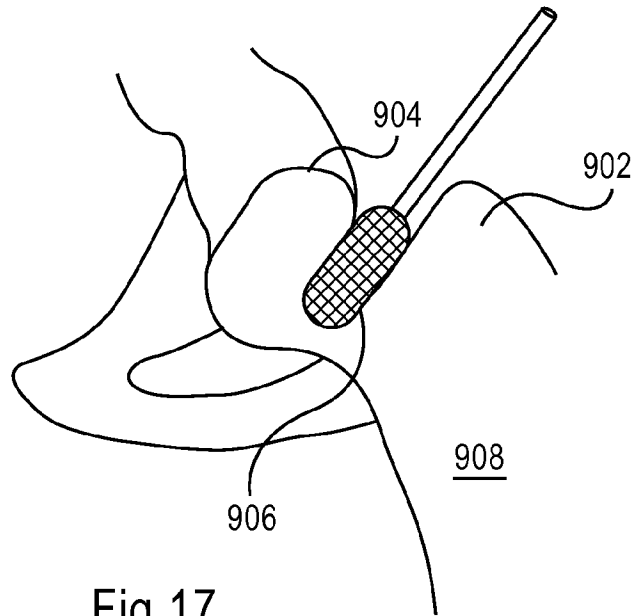

Fig.17

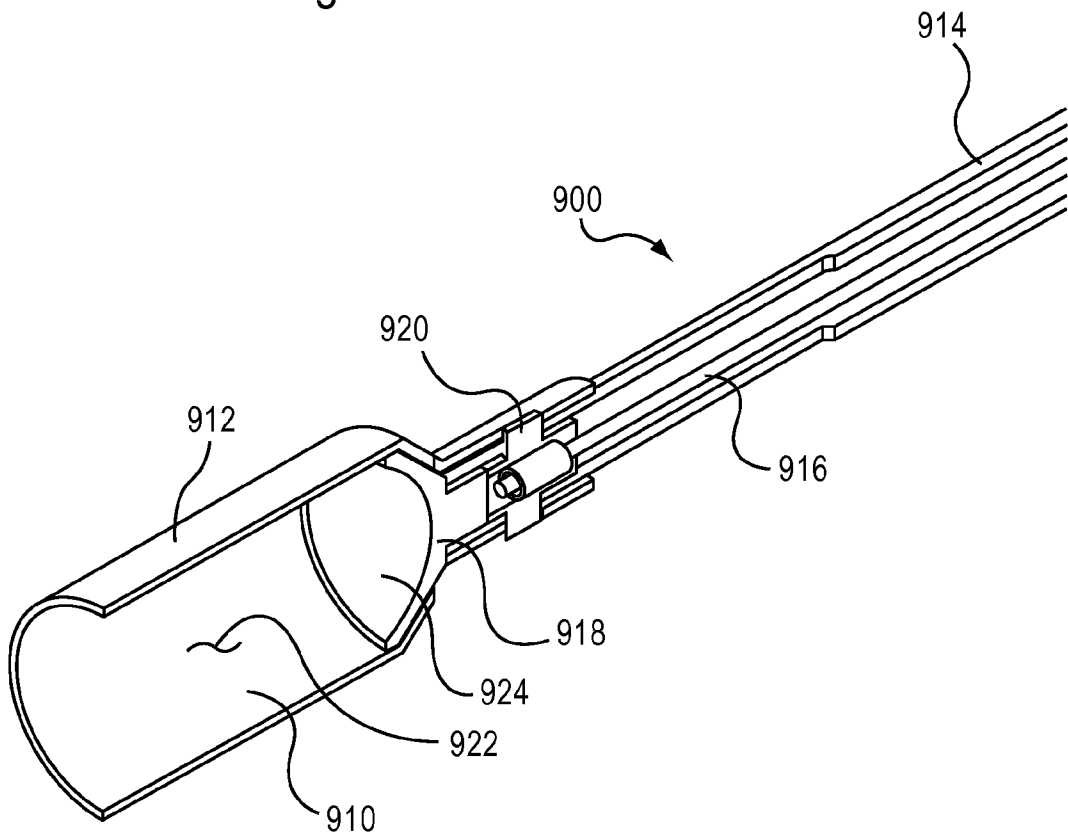

Fig.18

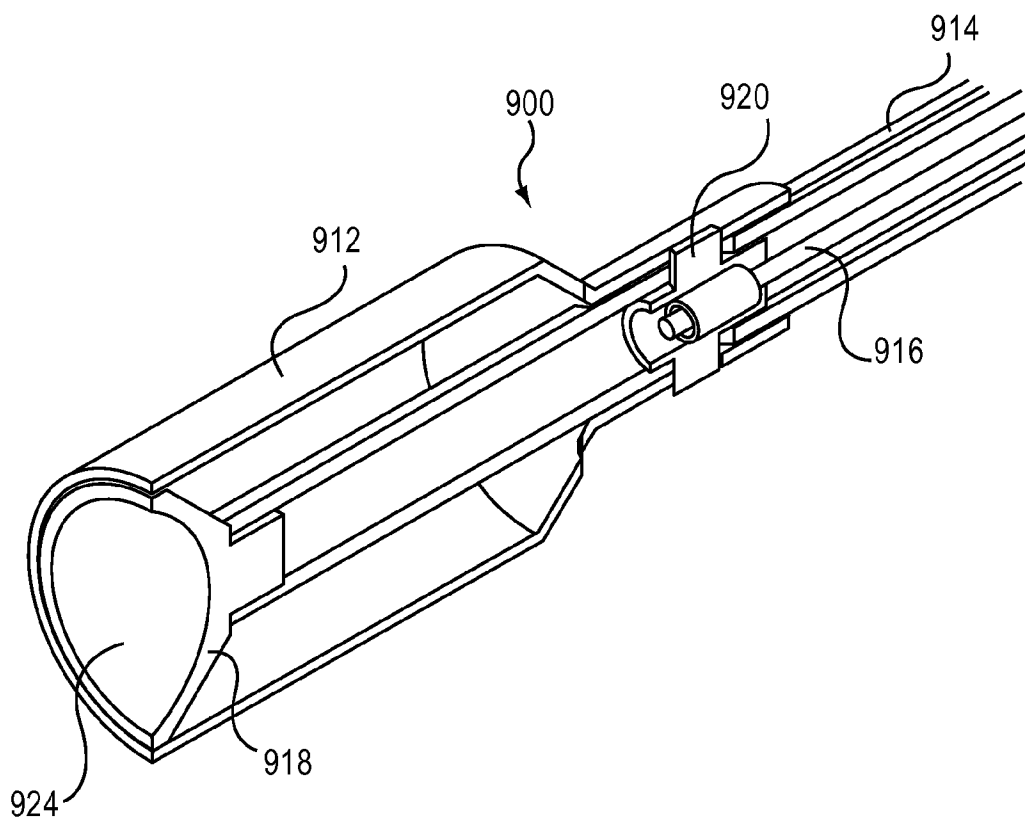

Fig.19

## INTERNATIONAL SEARCH REPORT

International application No.

PCT/US2008/081540

## A. CLASSIFICATION OF SUBJECT MATTER

IPC(8) - A61B 17/20 (2008.04)

USPC - 604/22

According to International Patent Classification (IPC) or to both national classification and IPC

## B. FIELDS SEARCHED

Minimum documentation searched (classification system followed by classification symbols)

IPC(8) - A61B 1/00, 17/20, 17/58, 19/00; A61M 25/00, 29/00, 31/00 (2008.04)

USPC - 128/898, 600/114, 115; 604/22, 96.01, 264, 509, 523; 606/99

Documentation searched other than minimum documentation to the extent that such documents are included in the fields searched

Electronic data base consulted during the international search (name of data base and, where practicable, search terms used)

PatBase, Google Search

## C. DOCUMENTS CONSIDERED TO BE RELEVANT

Category*	Citation of document, with indication, where appropriate, of the relevant passages	Relevant to claim No.
X	WO 2000/23009 A1 (FRAUENS) 27 April 2000 (27.04.2000) entire document	1-8, 21-25
--		-----
Y		9-20
Y	US 2001/0001315 A1 (BATES et al) 17 May 2001 (17.05.2001) entire document	9-11, 16-17
Y	US 5,342,386 A (TROTТА) 30 August 1994 (30.08.1994) entire document	12-20
A	US 2003/0004460 A1 (BEDELL) 02 January 2003 (02.01.2003) entire document	1-25
A	US 2006/0015171 A1 (ARMSTRONG) 19 January 2006 (19.01.2006) entire document	1-25
A	WO 1992/22259 A2 (HOOD et al) 23 December 1992 (23.12.1992) entire document	1-25

 Further documents are listed in the continuation of Box C.

## \* Special categories of cited documents:

"A" document defining the general state of the art which is not considered to be of particular relevance

"E" earlier application or patent but published on or after the international filing date

"L" document which may throw doubts on priority claim(s) or which is cited to establish the publication date of another citation or other special reason (as specified)

"O" document referring to an oral disclosure, use, exhibition or other means

"P" document published prior to the international filing date but later than the priority date claimed

"T" later document published after the international filing date or priority date and not in conflict with the application but cited to understand the principle or theory underlying the invention

"X" document of particular relevance; the claimed invention cannot be considered novel or cannot be considered to involve an inventive step when the document is taken alone

"Y" document of particular relevance; the claimed invention cannot be considered to involve an inventive step when the document is combined with one or more other such documents, such combination being obvious to a person skilled in the art

"&amp;" document member of the same patent family

Date of the actual completion of the international search

26 December 2008

Date of mailing of the international search report

21 JAN 2009

Name and mailing address of the ISA/US

Mail Stop PCT, Attn: ISA/US, Commissioner for Patents

P.O. Box 1450, Alexandria, Virginia 22313-1450

Facsimile No. 571-273-3201

Authorized officer:

Blaine R. Copenheaver

PCT Helpdesk: 571-272-4300

PCT OSP: 571-272-7774