

March 26, 1968

G. TIGGES
APPARATUS FOR THE INSERTION OF A CORE INTO THE
AXIAL OPENING OF YARN SPOOLS

3,374,959

Filed Dec. 17, 1965

2 Sheets-Sheet 1

Fig. 1

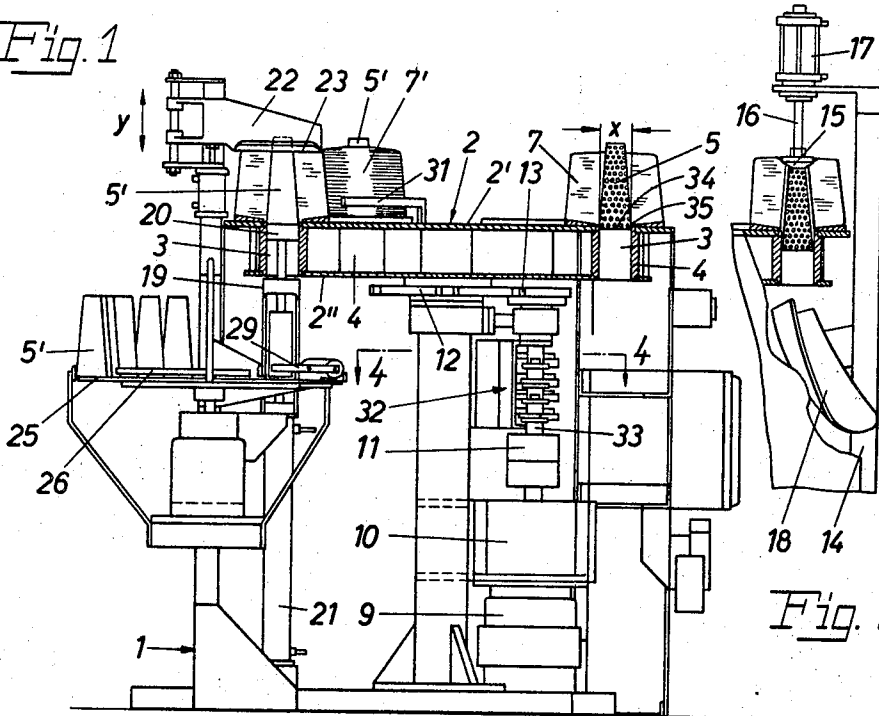

Fig. 2

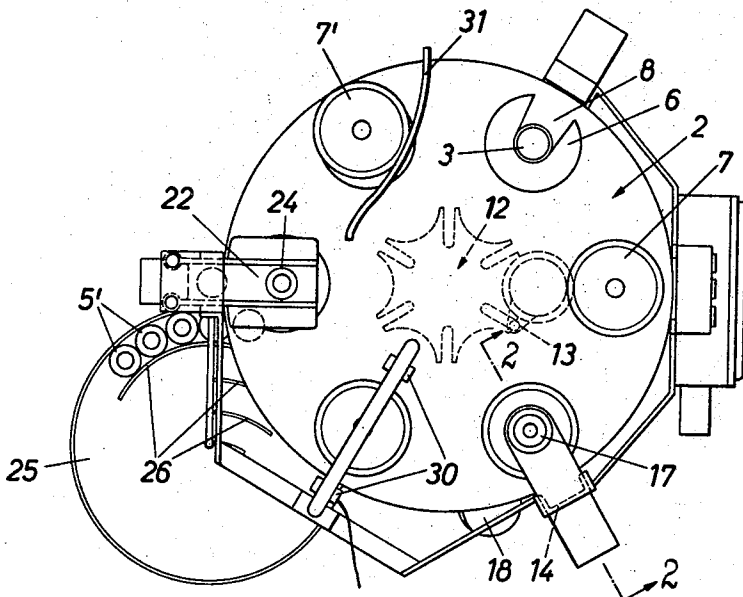

Fig. 3

LIGHT BEAM 30 CONTROLS ENTIRE
OPERATION THROUGH SWITCH 32 (FIG. 1)

INVENTOR.
Gerhard Tigges
BY *Luettgen & Tague*
Attorney

March 26, 1968

G. TIGGES

3,374,959

APPARATUS FOR THE INSERTION OF A CORE INTO THE
AXIAL OPENING OF YARN SPOOLS

Filed Dec. 17, 1965

2 Sheets-Sheet 2

Fig. 4

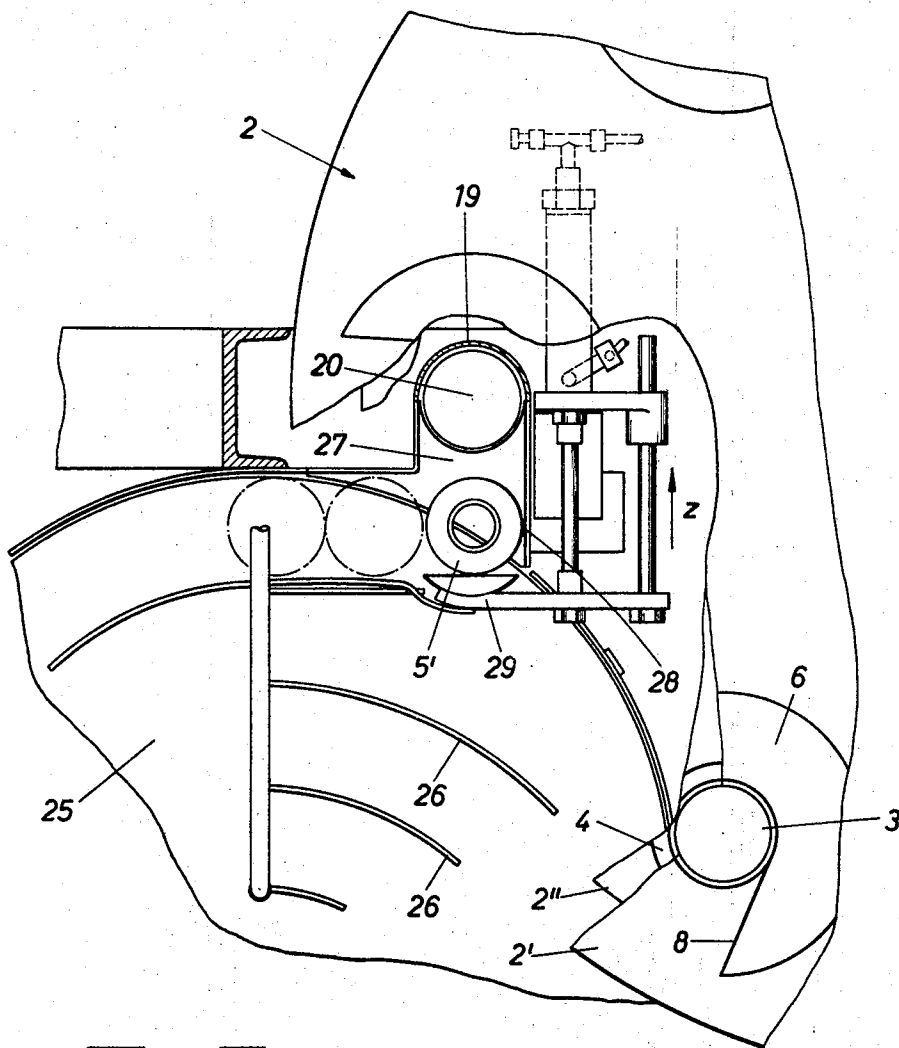
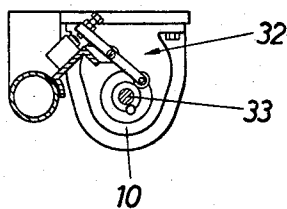

Fig. 5

INVENTOR.

Gerhard Tigges
Ernest Montagne
Attorney

BY

1

2

3,374,959

APPARATUS FOR THE INSERTION OF A CORE INTO THE AXIAL OPENING OF YARN SPOOLS

Gerhard Tigges, Wuppertal-Cronenberg, Germany, assignor to Lebrecht Tigges, Wuppertal-Barmen, Germany, a corporation of Germany

Filed Dec. 17, 1965, Ser. No. 514,504

Claims priority, application Germany, Dec. 19, 1964,

T 27,672

6 Claims. (Cl. 242—1)

ABSTRACT OF THE DISCLOSURE

An apparatus for the ejection and insertion of a core into the axial opening of yarn spools or the like, which comprises a frame and a table movably mounted on the frame. A yarn wind is supported on the table and moves with the table past a plurality of working positions. First means for ejecting in one of said working positions of one core are disposed in an axial recess of the yarn spool from the upper side of the table, and second means for injecting in another of the working positions of another core from the lower side of said table are arranged. The table has passage openings having a diameter substantially equal with the largest diameter of the cores, and the first means for ejecting and the second means for injecting operate through the passage openings of the table.

The present invention relates to an apparatus for the insertion of a core into the axial opening of yarn spools or the like.

Yarn spools or the like carry in their axial opening so-called cores, which comprise generally pasteboard tubes or metal tubes of truncated cone shape or radially resilient wire sleeves. For the dyeing process generally, the pasteboard tubes, which originate from the spooling process, are exchanged to metal tubes consisting of perforated sheet metal or of resilient wire. In order to keep down the necessary number of these metal tubes as much as possible, generally the metal tube is exchanged again to a pasteboard tube after the dyeing process. If the yarn winding has been spooled directly on a metal tube, it is dyed in this position. After the dyeing process, the metal tube is exchanged again, however, to a pasteboard tube. This is brought about again in order that not too many metal tubes are required, as dye spools are available in storage.

In order to make possible the removal of the core disposed in the axial recess of the yarn spool, in a manner protecting the positions of the yarn and in order to obtain a greater output, it has been proposed before to perform by mechanical means the exchange of the cores. In these devices automatized to a great extent, this core rests on a moving table and passes in different working positions of this device, of which at least one of the working positions serves the purpose to eject the core disposed in the axial recess of the yarn spool, while at least one additional working position is provided in order to inject the other core. The constructive arrangement of these automatic devices is substantially such that a spindle vertically reciprocating relatively to the moved table and a vertically reciprocating tube, respectively, is provided. During the upward movement the ejection of the core takes place. During the downward movement the new core is inserted into the axial recess. It is of advantage in these proposed devices, in addition to the great output, first of all the fact that the core is secured in its position on the moving table during the transportation from the ejection position into the injection position through the spindle projecting through the axial recess. It has been found that

in connection with particular yarn spools, the ejection of the core in upward direction is of a disadvantage. This applied particularly to such spool yarns, the yarn positions of which are still sufficiently loose, after the dyeing in the outer range thereof, however, within the inner range show an appreciable hardening, adjacent the core, due to the shrinking of the yarn occurring during the dyeing, which hardening makes appreciably more difficult the ejection of the present core and the proper injection of the new core. During the ejection in upward direction, the danger always exists that the inside disposed yarn positions are pulled along during such movement.

In order to provide for the yarn spools of this type an automatic device, having a great output, for the protecting ejection and injection of a core, it is one object of the present invention to provide such a device for insertion of a core into the axial opening of the yarn spools or the like, wherein the table has passage openings of about the largest diameter of the core, whereby the ejection of the core from the upperside of the table and injection of the new core in the lower side of the table takes place and in particular always through the passage opening of the table.

It is another object of the present invention to provide an apparatus for the insertion of a core into the axial opening of yarn spools or the like which includes a picker pusher causing the ejection of the core by pushing the end face of the core, which has a smaller cross-section.

Furthermore, it is still another object of the present invention to provide an apparatus for the insertion of a core into the axial opening of yarn spools or the like, wherein the injection of the new core takes place by means of a lifting head, which enters into the passage opening of the table formed as rotary table, whereby it is of advantage in accordance with the present invention to provide a holding-down member engaging the upper side of the yarn winding in the injection position. An advantageous embodiment comprises furthermore, in accordance with the present invention, an arrangement wherein the core to be injected stands in the injection-ready position within a half tube disposed axially below the passage opening of the table.

It is another object of the present invention to provide an apparatus for the insertion of a core in the axial opening of yarn spools or the like, wherein a feeding of the core takes place in radial direction from a rotary table magazine receiving the cores.

Due to the arrangement, in accordance with the present invention, a structure of the device is realized which has a great output and which makes it possible in a simple space saving arrangement independently from the often varying structure of the core to provide a protecting ejection of the present yarn winding and a protecting injection of the new yarn core. Due to the fact that the yarn core is ejected during the ejection from above through the passage opening of the rotary table, it can be prevented with sufficient safety that even in the case of a corresponding hard structure in the inner range of the yarn winding, a protecting ejection takes place without danger that the yarn positions are pulled along during the ejection movement. The passage opening in the rotary table can be adjusted as to its diameter with sufficient exactness to the largest diameter of the yarn core, so that also the yarn positions disposed closest to the yarn core still have a sufficient support on the engaging face of the rotary table. Since the yarn cores disposed in the axial recess of the yarn spool project generally on both sides slightly beyond the end faces of the core, there is no difficulty to mount the yarn spool with the corresponding exactness on the rotary table. The end of the yarn core projecting beyond one end face brings about a cen-

tering position relative to the passage opening of the rotary table by projecting into this passage opening. The core can be moved with appreciable angular speed into the ejection position. The end of the core projecting upwardly at the opposite end face of the yarn spool makes possible a slight fit-like ejection by means of the picking member. Since the yarn core has generally the shape of a truncated cone, the core falls easily upon engagement by the picking pusher through the passage opening of the rotary table. Already the bullet-like accelerations, obtained by means of such picking pusher, reduce the danger that the yarn positions are pulled along during such ejection movement. It has been found that the core, which is freely disposed on the rotary table, can be moved further with the same sufficiently large angular speeds of the rotary table, without changing its position, particularly if the rotary table is equipped with corresponding receiving recesses complementary to the member received, which surround the passage of the rotary table. In the injecting position, the new yarn cores are then inserted into the yarn winding from above by means of a holding-down member. Already by the passage opening of the rotary table, a sufficient centering insertion of the yarn core into the axial recess of the yarn spool is obtained. The truncated cone shape of the core is again contributing to a favorable effect.

With these and other objects in view which will become apparent in the following detailed description, the present invention will be clearly understood in connection with the accompanying drawings, in which:

FIGURE 1 is a cross-section of the apparatus, designed in accordance with the present invention;

FIG. 2 is a section through the apparatus in an intermediate position of the ejection process along the lines 2—2 of FIG. 3;

FIG. 3 is a top plan view of the apparatus;

FIG. 4 is a section along the lines 4—4 of FIG. 1; and

FIG. 5 is a part section through the apparatus in the injection position of the machine.

Referring now to the drawings, the apparatus comprises a machine frame 1, on which a table 2 is movably mounted. In the present embodiment, the table 2 is designed as a rotary table. It comprises two rotary table plates 2' and 2'' disposed parallel to and spaced apart from each other. The table 2 is equipped with passage openings 3. The latter comprise distancing tubes 4 which simultaneously hold together the plates 2' and 2'' of the rotary table.

The passage openings 3 correspond as to their diameter to the largest diameter x of the cores 5.

Disks 6 are disposed above the passage openings 3, which form with their upper side mounting recesses, which are adjusted to one end face of the yarn cheese 7. The disks 6 have a radial open slot 8.

The rotary table 2 is driven stepwise by means of a motor 9 over a drive 10 and clutch 11 including a Maltese cross 12 which engages a cam 13.

In order to bring about the ejection position, a picking pusher 15 is provided on a stand 14, the pusher rod 16 of the picking pusher 15 being coupled with a pneumatic piston, which reciprocates in a pneumatic cylinder 17. The stepwise movement of the rotary table 2 is arranged such that after each step a passage opening 3 is disposed below the picking pusher 15.

A groove 18 is provided axially aligned and below the picking pusher 15 in the machine frame 1, in order to catch the cores 5 driven through the passage opening 3 and to feed the same to a collecting container.

In order to obtain the injection position, a half tube 19 is disposed immovably at another point below the rotary table 2. The half tube 19 is mounted such that likewise after each stepwise movement of the rotary table 2, a passage opening 3 is exactly above the half tube 19. The ejection position and the injection position

are disposed 120° apart relative to each other, while the passage openings 3 have an angular distance of 60° relative to each other. Each passage opening 3 reaches thus only after each second advancing step of the rotary table 2 the range of the injection position.

A lifting head 20 is arranged axially relative to the half tube 19. The lifting head 20 is likewise pneumatically operated, by reciprocating a piston in the pneumatic cylinder 21. The lifting head 20 enters during its upward movement the passage opening 3 of the rotary table 2 disposed thereabove. The lifting head 20 feeds the new core 5' in upright position upwardly into the axial recess of the yarn spool 7' mounted on the rotary table 2.

A vertically reciprocating holding-down member 22 engages in the direction of the arrow y , during the injection process the upper end face 23 of the yarn spool 7'. The holding-down member 22 is likewise controlled within the cycle. Its slowest position is always obtained during standstill of the rotary table only. The holding-down member 22 has an opening 24, which corresponds about to the diameter of the narrower end of the core 5', into which opening 24 this narrower end of the core 5' enters during the injection process.

The individual cores are fed in radial direction in the direction of the arrow z (FIG. 5) into the injection-ready position and particularly from a magazine 25. The latter rotates continuously. It is equipped with guide sheets 26, which provide that the cores, disposed in standing position on the magazine plate 25, are always fed in outward direction. Thereby, they are fed jamming into a channel 27 disposed tangentially to the magazine plate 25 towards a wall 28. The forwardmost disposed core 5' is brought within the operation of the cycle from a feeding pusher 29 standing on the lifting head 20, which is in its lowermost position. In the range between the ejection position and the injection position a light beam 30 is provided (FIG. 3). This light beam 30 causes the picking pusher not to start operation, if during the corresponding step-in, the holding position of the rotary table 2, the light rays of the light beam 30 are not interrupted.

A deviating sheet 31 is provided behind the injection position taken in the direction of rotation, which strips the yarn spools 7' equipped with a new core from the rotary table.

The entire stepwise control of the rotary table 2, of the picking pusher 15, of the holding-down member 22, of the lifting head 20 and of the pusher 29 is controlled by a switching member 32, which is mounted on the driving axis 33 of the rotary table 2. The light beam 30 controls the entire operation through the switching member 32.

The operation of the apparatus designed in accordance with the present invention is performed in the following manner:

The yarn spool, containing the core to be ejected, is positioned looking in rotary direction prior to the ejection position on the rotary table 2. The adjusted position can be easily obtained, because generally one end 34 of the core 5 projects beyond the lower end face 35 of the yarn spool 7 and can be guided therefore in the passage opening 3 and in the opening of the carrying plate disposed thereabove, respectively. This yarn spool is then moved during next or second next rotary step of the rotary table 2 below the picking pusher 15. The latter falls down hittingly downwardly. The yarn core 5 is ejected through the passage opening 3 of the rotary table 2 in downward direction. Upon lifting of the picking pusher 15, the rotary table 2 moves one step further. The next yarn winding is moved into the ejection position. During the rotary step of the table 2 taking place thereafter again, the first yarn winding moves into the injection position. The pusher 29 has moved a core 5' onto the lifting head 20. The holding-down member 22 moves downwardly. The yarn spool is now clamped be-

5

tween the rotary table 2 and the holding-down member 22. The lifting head 20 moves then upwardly and ejects a new core 5' into the axial opening of the yarn spool 7'. The lifting head 20 moves upwardly and pushes the new core 5' into the axial opening of the yarn spool 7'. The lifting head 20 moves again downwardly. The holding-down member 22 is again lifted. The rotary table 2 moves now one step forward. The yarn winding 7' equipped with a new core 5' is stripped off by the sheet 31 from the rotary table 2.

While I have disclosed one embodiment of the present invention, it is to be understood that this embodiment is given by example only and not in a limiting sense, the scope of the present invention being determined by the objects and the claims.

I claim:

1. An apparatus for the ejection and insertion of a core into the axial opening of yarn spools or the like, comprising

a frame,

a table movably mounted on said frame,

a yarn wind supported on said table and moving with said table past a plurality of working positions,

first means for ejecting in one of said working positions one core disposed in an axial recess of the yarn spool from the upper side of said table,

second means for injecting in another of said working positions of another core from the lower side of said table,

said table having passage openings having a diameter substantially equal with the largest diameter of said cores, and

said first means for ejecting and said second means for injecting operating through said passage openings of said table.

6

2. The apparatus, as set forth in claim 1, wherein said means for ejecting said one core comprises a picking pusher engaging one end of said core having smaller cross-section.

3. The apparatus, as set forth in claim 1, wherein said second means for injecting said another core comprises a lifting head entering said passage openings of said table.

4. The apparatus, as set forth in claim 3, which includes
a holding-down member engaging the upper side of a yarn wind in said another of said working positions.

5. The apparatus, as set forth in claim 3, which includes
a half-tube disposed axially below at least one of said passage openings of said table and receiving a core in a ready-to-position to be injected.

6. The apparatus, as set forth in claim 1, which includes
a rotary table magazine receiving said core in upright standing position, and
guide means for feeding said core in axial direction toward said first mentioned table.

References Cited

UNITED STATES PATENTS

2,445,998 7/1948 Drake ----- 242-1
2,736,184 2/1956 Harvey et al. ----- 242-81 X

FRANK J. COHEN, *Primary Examiner.*

NATHAN L. MINTZ, *Examiner.*

35