

(19) (KR)
(12) (Y1)

(51) 。 Int. Cl.7
A47K 3/28

(45)
(11)
(24)

2003 10 30
20-0331663
2003 10 20

(21) 20-2003-0025339
(22) 2003 08 06

(73) 201-1503 38/2

(72) 201-1503 38/2

(74)

가 :

(54)

(2) (1) (14)가 (10) , (32a) (32)가 (30)
(11) (12) (10); (30)가 (11)가 (11)
(12) (40) (21) (10) (20); (10) (30)
(20) (21) (30)가 (30)

7b

,

- 1
- 2
- 3
- 4
- 5
- 6
- 7a
- 7b

< >

- (1) : (10) :
- (11) : (12) :
- (13) : (14) :
- (20) : (21) :
- (30) : (31) :
- (31a) : (31b) :
- (32) : (32a) :
- (40) :

,

.

가 ,

가

.

가

가 , 가 가 , 가 .

가 , 가 가

(2) (32)가 (14)가 (10) , (10) (32a)
(30) (30) (1)

(30)가 (11)가 (11) (12)
(13)가 (10);

(10) (11) (30)
(20);

(10) (11) (31) (31)
(12) (31a) (30);

(12) (31a) (10) (30) (40)

2a) (30) (31) (32) (13) (3)
(31b)

(20) (30)
(21) (21)

(10) (30) (30)가 (40) (10)

(30)가 (10) (30)가 (13) (31b) (30)
(10) (31b)

(2) (10) (30)가 (10)
(13) (31b) (30)

(32a)

0) (32a) (3) ,
(30) 7a (40) (30)가
(30) (31b) (13) (31)가 (13)

(13) (31b) (30) (32a) (10)
 (40) (30)가 (10) 가
 7b (10) (11) (20) 180° (30)
 (30) (31b) (20) (21) (21)

가 가

가 가
 가 가 가 가

(57)

1.

(2) (14)가 (10) (10) (32a)
 (32)가 (30)

(30)가 (11)가 (11) (12)
 (13)가 (10);

(10) (11) (30)
 (20);

(10) (11) (31) (31)
 (12) (31a) (31b) (32) (31)
 (13) (32a) (31b) (30);

(12) (31a) (10) (30) (40)

2.

1 (30)가 (40) (10)

3.

1 (20) (30)
 (21)

4.

3 (21) (20)

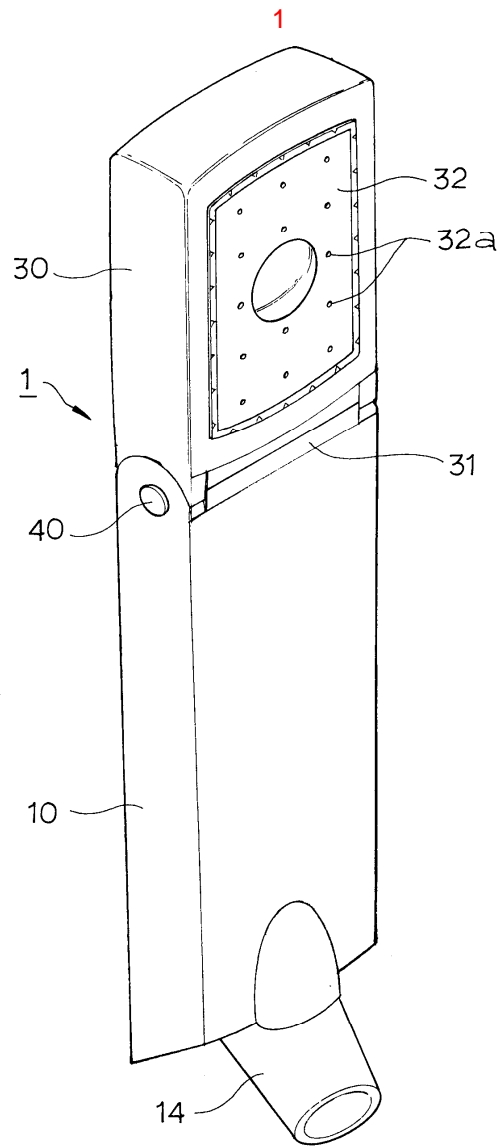

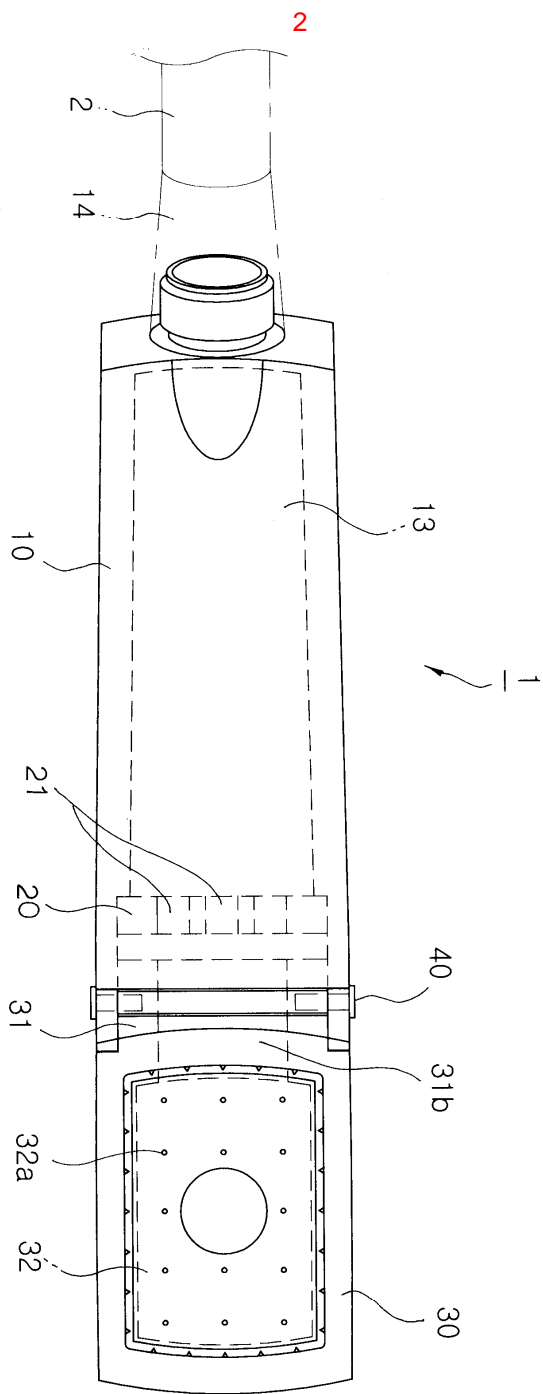

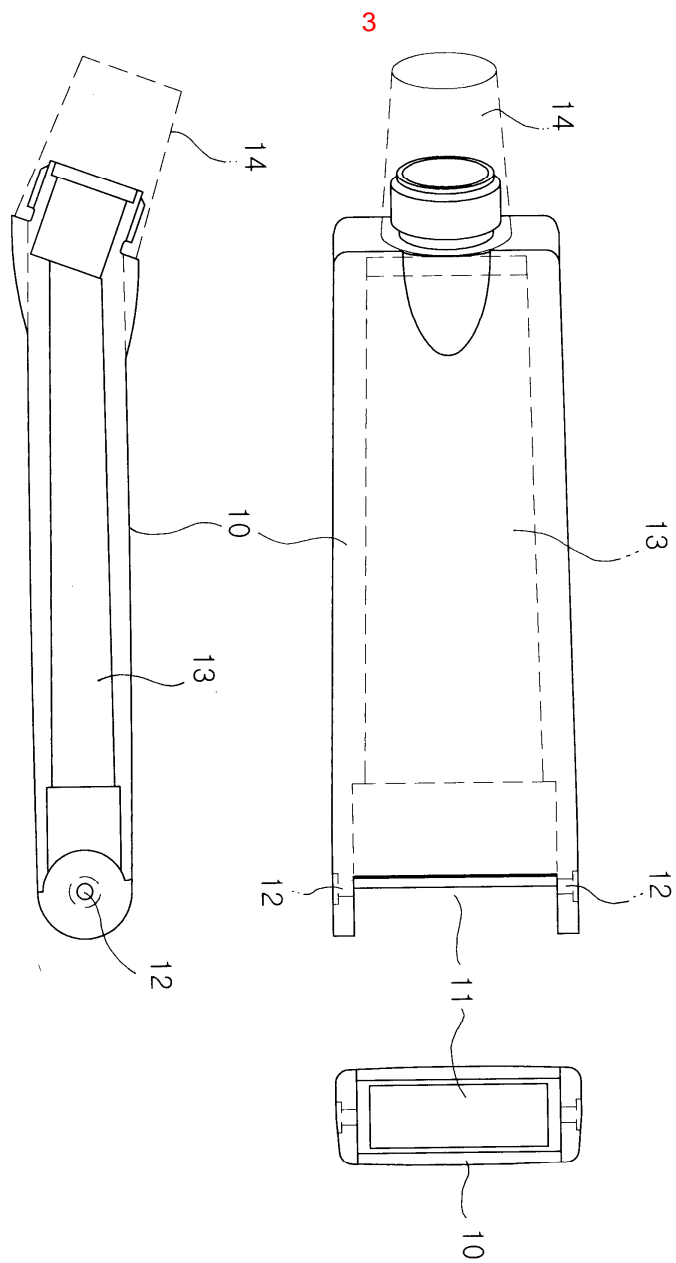

4

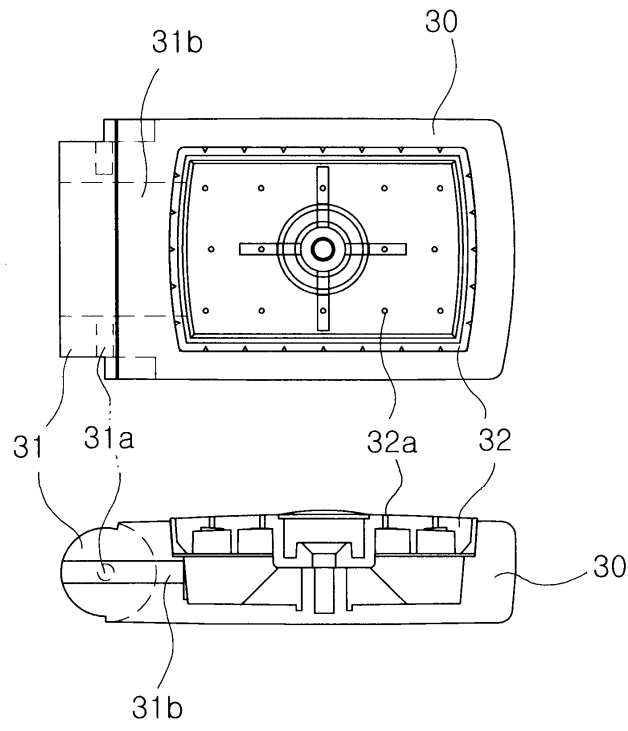

5

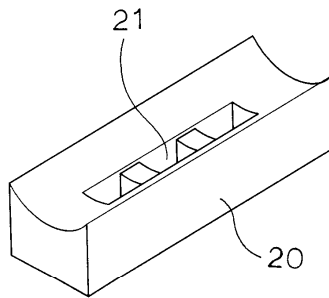

6

