

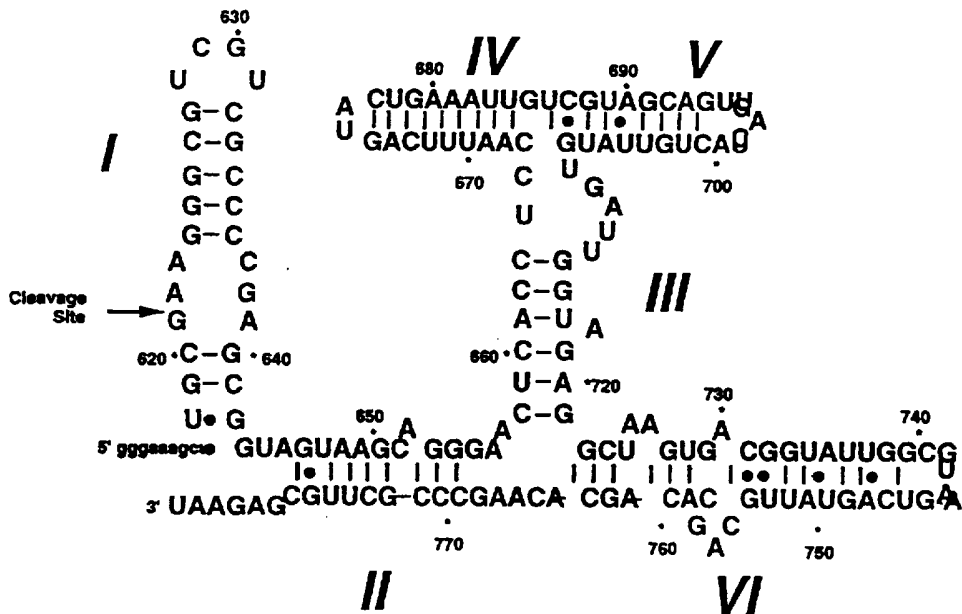

INTERNATIONAL APPLICATION PUBLISHED UNDER THE PATENT COOPERATION TREATY (PCT)

<p>(51) International Patent Classification <sup>6</sup> : C12N 15/52, 9/00, C12Q 1/68</p>	<p>A1</p>	<p>(11) International Publication Number: <b>WO 96/19577</b> (43) International Publication Date: 27 June 1996 (27.06.96)</p>
<p>(21) International Application Number: PCT/IB95/00141 (22) International Filing Date: 23 February 1995 (23.02.95) (30) Priority Data: 08/363,774 22 December 1994 (22.12.94) US (71)(72) Applicant and Inventor: COLLINS, Richard [CA/CA]; 6 Longboat Avenue, Toronto, Ontario M5A 4E1 (CA). (74) Agents: CONN, David, L. et al.; Smart &amp; Biggar, 900 - 55 Metcalfe Street, P.O. Box 2999, Station D, Ottawa, Ontario K1P 5Y6 (CA).</p>	<p>(81) Designated States: AU, CA, JP, KR, MX, European patent (AT, BE, CH, DE, DK, ES, FR, GB, GR, IE, IT, LU, MC, NL, PT, SE).  <b>Published</b> <i>With international search report.</i></p>	

(54) Title: VS RIBOZYMES



(57) Abstract

Ribozyme able to cleave a separate substrate RNA molecule, said ribozyme having three base-paired regions generally, but not limited to, in a proposed "I" configuration, wherein "upper" and "lower" base-paired regions comprise between about 4 and 80 bases inclusive of which at least about 50 % are paired with each other, and wherein the "connecting" region between said upper and lower base paired regions comprises between about 4 and 20 bases inclusive of which at least about 50 % are paired.

**FOR THE PURPOSES OF INFORMATION ONLY**

Codes used to identify States party to the PCT on the front pages of pamphlets publishing international applications under the PCT.

AT	Austria	GB	United Kingdom	MR	Mauritania
AU	Australia	GE	Georgia	MW	Malawi
BB	Barbados	GN	Guinea	NE	Niger
BE	Belgium	GR	Greece	NL	Netherlands
BF	Burkina Faso	HU	Hungary	NO	Norway
BG	Bulgaria	IE	Ireland	NZ	New Zealand
BJ	Benin	IT	Italy	PL	Poland
BR	Brazil	JP	Japan	PT	Portugal
BY	Belarus	KE	Kenya	RO	Romania
CA	Canada	KG	Kyrgystan	RU	Russian Federation
CF	Central African Republic	KP	Democratic People's Republic of Korea	SD	Sudan
CG	Congo	KR	Republic of Korea	SE	Sweden
CH	Switzerland	KZ	Kazakhstan	SI	Slovenia
CI	Côte d'Ivoire	LI	Liechtenstein	SK	Slovakia
CM	Cameroon	LK	Sri Lanka	SN	Senegal
CN	China	LU	Luxembourg	TD	Chad
CS	Czechoslovakia	LV	Latvia	TG	Togo
CZ	Czech Republic	MC	Monaco	TJ	Tajikistan
DE	Germany	MD	Republic of Moldova	TT	Trinidad and Tobago
DK	Denmark	MG	Madagascar	UA	Ukraine
ES	Spain	ML	Mali	US	United States of America
FI	Finland	MN	Mongolia	UZ	Uzbekistan
FR	France			VN	Viet Nam
GA	Gabon				

VS RIBOZYMESBackground Of The Invention

This invention relates to ribozymes.

5 The following is a brief description of publications concerning ribozymes, and in particular, VS ribozymes. None are admitted to be the prior art to the pending claims, and all are incorporated by reference herein.

10 Six basic varieties of naturally-occurring enzymatic nucleic acids are known presently. Each can catalyze the hydrolysis of RNA phosphodiester bonds in *trans* (and thus can cleave other RNA molecules) under physiological conditions. Table I summarizes some of the characteristics of these ribozymes.

15 In general, enzymatic nucleic acids act by first binding to a target RNA. Such binding occurs through the target binding portion of a enzymatic nucleic acid which is held in close proximity to an enzymatic portion of the molecule that acts to cleave the target RNA. Thus, the  
20 enzymatic nucleic acid first recognizes and then binds a target RNA through complementary base-pairing, and once bound to the correct site, acts enzymatically to cut the target RNA. Strategic cleavage of such a target RNA will destroy its ability to direct synthesis of an encoded  
25 protein. After an enzymatic nucleic acid has bound and cleaved its RNA target, it is released from that RNA to search for another target and can repeatedly bind and cleave new targets.

30 The enzymatic nature of a ribozyme is advantageous over other technologies, such as antisense technology (where a nucleic acid molecule generally simply binds to a nucleic acid target to block its translation) since the concentration of ribozyme necessary to affect a

therapeutic treatment is lower than that of an antisense oligonucleotide. This advantage reflects the ability of the ribozyme to act enzymatically. Thus, a single ribozyme molecule is able to cleave many molecules of target RNA. In addition, the ribozyme is a highly specific inhibitor, with the specificity of inhibition depending not only on the base-pairing mechanism of binding to the target RNA, but also on the mechanism of target RNA cleavage. Single mismatches, or base-substitutions, near the site of cleavage can completely eliminate catalytic activity of a ribozyme. Similar mismatches in antisense molecules do not prevent their action (Woolf *et al.*, 1992 *Proc. Natl. Acad. Sci. USA* 89, 7305-7309). Thus, the specificity of action of a ribozyme is greater than that of an antisense oligonucleotide binding the same RNA site.

A small number of RNAs isolated from a variety of natural sources have been found to possess a self-cleavage activity that is involved in processing multimeric transcripts into monomers, apparently as part of the replication cycle. Several different RNA sequences and secondary structures appear to be capable of such activity. These include the hammerhead, found in several plant viral satellite RNAs, a viroid RNA, and the transcript of a nuclear satellite DNA of a newt (reviewed by Symons, 1992 *Annu. Rev. Biochem.* 61, 641); the hairpin (or paper-clip) in the minus strand of the satellite of tobacco ringspot virus and related viruses (Buzayan *et al.*, 1986 *Nature* 323, 349; Feldstein *et al.*, 1990 *Proc. Natl. Acad. Sci. USA* 87, 2623); the genomic and antigenomic RNAs of hepatitis delta virus (HDV; Sharmeen *et al.*, 1988 *J. Virol.* 62, 2674; Kuo *et al.*, 1988 *J. Virol.* 62, 4439; Perrotta and Been, 1991 *Nature* 350, 434); and Varkud Satellite (VS) RNA in the mitochondria of certain *Neurospora* isolates (Saville and Collins, 1990 *Cell* 61, 685).

In their natural contexts the ribozymes mentioned above, as well as others such as Group I (Cech, 1990 *Annu. Rev. Biochem.* 59, 543) and Group II introns (Michel et al., 1989 *Gene* 82, 5), perform intramolecular self-cleavage and, in some cases, ligation reactions. Structure-function studies of Group I introns (Zaug and Cech, 1986 *Science* 231, 470; Szostak, 1986 *Nature* 322, 83) and later hammerhead (Uhlenbeck, 1987 *Nature* 328, 596), hairpin (Feldstein et al., 1990 *supra*; Hampel et al., 1990 *Nucleic Acids Res.* 18, 299), and HDV (Perrotta and Been, 1992 *Biochemistry* 31, 16; Branch and Robertson, 1991 *Proc. Nat. Acad. Sci. USA* 88, 10163) ribozymes have been facilitated by altering these RNAs to perform intermolecular trans-cleavage reactions. In a trans-cleavage reaction one RNA, the substrate, contains the site to be cleaved; a separate RNA, the ribozyme, provides the sequences required to catalyze the cleavage. One naturally-occurring trans-acting ribozyme has been discovered: the RNA component of RNase P, which cleaves pre-tRNA precursors in trans (Guerrier-Takada et al., 1983 *Cell* 35, 849). Trans-cleavage reactions of most ribozymes have been designed such that binding of the substrate occurs via formation of multiple Watson-Crick base pairs with the ribozyme. Non-Watson-Crick and tertiary interactions are also involved in substrate binding and may be essential for proper binding (Pyle et al., 1992 *Nature* 358, 123; Dib-Hajj et al., 1993 *Nucl. Acids Res.* 21, 1797; Smith et al., 1992 *J. Biol. Chem.* 267, 2429; Guerrier-Takada and Altman, 1993 *Biochemistry* 32, 7152). With hammerhead, hairpin and Group I ribozymes it has been found that very few specific nucleotides in the substrate are required for trans cleavage, provided that the adjacent region(s) are complementary to the binding site on the ribozyme. This property has allowed the engineering of ribozymes that can cleave sequences other than those recognized by the naturally-occurring ribozyme. Some engineered ribozymes also function *in vivo* in non-native host cells, which has raised the possibility of

their use as therapeutic agents in dominant inherited disorders and against retroviruses and RNA viruses (reviewed by Castanotto et al., 1992 *Critical Reviews in Eukaryotic Gene Expression* 2, 331).

5

#### Summary Of The Invention

This invention concerns novel catalytic nucleic acid which performs the same type of RNA cleavage as hammerhead, hairpin, and HDV ribozymes, leaving products with 2',3' cyclic phosphate and 5' OH termini (Saville and  
10 Collins, 1990 *supra*), but it is different in sequence, secondary structure, choice of cleavage site, and functional properties from *trans*-cleaving ribozymes known in the art (Collins and Olive, 1993 *Biochemistry* 32, 2795; Guo et al., 1993 *Mol. Biol.*, 232, 351).

15

This invention features the construction and use of enzymatic nucleic acid molecules, for example, those derived from *Neurospora Varkud* Satellite (VS) RNA, that can catalyze a *trans*-cleavage reaction, wherein a separate substrate RNA is cleaved at a specific target site. The  
20 minimal substrate may form a stable hairpin stem-loop base-paired structure (Fig. 6). Substrate recognition by the catalytic nucleic acid involves multiple, including tertiary interactions. The catalytic nucleic acid includes an RNA target binding domain which interacts with  
25 nucleotides of the target RNA (preferably with bases 3' of the cleavage/ligation site), and an enzymatic portion (which may include a part or all of the RNA substrate binding portion) having the enzymatic activity. The nucleic acid binds to the target RNA, preferably, with  
30 bases 3' of the cleavage/ligation site and causes cleavage of the RNA substrate at that cleavage site. Thus, in one aspect, the invention features a nucleic acid molecule that catalyzes the cleavage of a separate double-stranded RNA target molecule in a sequence-specific manner.

By "trans-cleavage" is meant that the ribozyme is able to act in trans to cleave another RNA molecule which is not covalently linked to the ribozyme itself. Thus, the ribozyme is not able to act on itself in an intramolecular cleavage reaction.

By "base-pair" is meant a nucleic acid that can form hydrogen or other bond(s) with other RNA sequence by either traditional Watson-Crick or other non-traditional types (for example Hoogsteen type) of interactions.

The enzymatic RNA molecules of this invention can be designed to cleave RNA (minimum length of between 8-20 nt) having only a preference for at least one nucleotide immediately 5' to the cleavage site and the availability of an adjacent 2' hydroxyl group for cleavage to occur. The 2'-hydroxyl group is generally provided by the substrate RNA molecule. Thus, these enzymatic RNA molecules provide significant *in vitro* and *in vivo* activities which can be used for diagnostic and therapeutic procedures.

Thus, in a first aspect, the invention features a ribozyme able to cleave a separate substrate RNA molecule. The ribozyme has three base paired regions generally in an "I" configuration. The upper and lower base paired regions of the proposed "I" include between about 10 and 80 bases inclusive, of which at least about 50% are paired with each other. The connecting region of the proposed "I" between said upper and lower base paired regions includes between about 8 and 20 bases inclusive, of which at least about 50% are paired.

By "ribozyme" is meant any enzymatic nucleic acid molecule, usually containing at least some ribonucleotides, which is active to cleave an RNA molecule without forming a covalent bond with that substrate. Thus, the molecule generally lacks any nucleophilic attacking group that is able to cause cleavage of the

substrate and form a covalent bond with that substrate (at least in a transient form).

5 A "separate RNA molecule" is one that is not covalently bonded with the ribozyme, and may contain non-ribonucleotides within its length. It is preferably a naturally occurring RNA molecule, such as a viral mRNA, or a pathogenic RNA molecule.

10 The proposed "I" configuration is shown generally in the figures 5B through 8. This structure may contain other nucleic acid chains attached to different portions of the "I", but those in the art will recognize that it is advantageous to have as few of these extra chains as possible so that secondary structure interactions are reduced and so that the size of the molecule is maintained as small as possible. The proposed "I" has an "upper" and "lower" region as describe above and these are connected by an intermediate ("connecting") region. Together these regions provide enzymatic activity to the ribozyme. While base pairing in these regions is important, those in the art will recognize that other types of pairing interactions, e.g., Hoogsteen pairing, are also useful in this invention. These regions may, as noted, include unpaired regions at the ends of the paired regions, or even within or intermediate these paired regions so long as enzymatic activity is not eliminated. By 50% base-pairing is meant that along a length of the region at least half of the bases in the region interact with other bases to hold the ribozyme in the generally an "I" shape. In preferred embodiments, there is at least 70 or even 80% base pairing, as is illustrated in the attached figures.

35 The proposed "I" configuration is meant to be a non-limiting structure. Those with ordinary skill in the art will recognize modifications (insertions, deletions, base-substitutions and/or chemical modifications) to the proposed "I" structure can be readily generated using techniques known in the art. Additionally, structures

distinct from the proposed "I" configuration can be readily generated by those skilled in the art and are within the scope of this invention.

5 In other preferred embodiments, the "connecting" region further includes a single-strand region of between about 3 and 7 bases inclusive, e.g., the single-strand region is adjacent the "upper" base-paired region as shown in figures 6-8 the "upper" region includes a "left" and "right" hand portion each between at least about 6 and 30 10 bases inclusive; and the "lower" region also includes a "left" and "right" hand portion each between at least about 6 and 30 bases inclusive. Such regions are delineated by the "connecting" region noted above and as shown in the figures.

15 In yet other preferred embodiments, the "lower" region and/or the "connecting" regions includes at least one bulged nucleotide (e.g., A), that is an unpaired base, which may be available for interaction with proteins; the "upper" base-paired region includes bases unpaired with 20 other bases in the "upper" base paired region which are available to base pair with a substrate RNA, e.g., as shown in the figures 8 and 9, where the bases which are unpaired include at least 3 bases. In addition, the substrate for the ribozyme has a base-paired region of at 25 least 2 base pairs, e.g., the substrate has the sequence 3' GANN 5' where cleavage by the ribozyme is between each N (each N independently is any base; throughout the document the term N or N' is independently any base or base equivalent).

30 In further preferred embodiments, the "lower" base-paired region has unpaired bases at its 5' end, available to base pair with a substrate RNA; the ribozyme contacts the RNA substrate only 3' of the cleavage site; the RNA substrate is a double-stranded RNA, and the nucleic acid 35 molecule is able to contact the double-stranded RNA substrate only 3' of the cleavage site and cause cleavage

of the RNA substrate at the cleavage site; the RNA substrate is a single-stranded RNA, and the ribozyme is able to contact the single-stranded RNA substrate only 3' of the cleavage site and cause cleavage of the RNA substrate at the cleavage site.

In a most preferred embodiment, the ribozyme is derived from *Neurospora* VS RNA. That is, the ribozyme has the essential bases of the VS RNA molecule held together in a suitable configuration as described above so that RNA substrates can be cleaved at the cleavage site. Such essential bases and configuration are determined as described below; those in the art will recognize that it is now routine to determine such parameters. One example of such a ribozyme is that having about 80 - 90% the sequence shown in the figures 5-8.

In other embodiments, the ribozyme is enzymatically active to cut an RNA duplex having at least two base-pairs; the ribozyme is enzymatically active to cut 5' to the sequence, 5'NAGN<sub>n</sub>GUCN<sub>m</sub> 3' (see Fig. 6B), where each N is independently any nucleotide base, n and m are independently an integer between 3 and 20 inclusive, and the sequence forms at least two intramolecular base-pairs; the RNA substrate binds the ribozyme at a site distant from the cleavage site; the ribozyme is a circular molecule, where the circular molecule contacts a separate RNA substrate and causes cleavage of the RNA substrate at a cleavage site; and the ribozyme includes RNA.

In other aspects, the invention features a cell including nucleic acid encoding the ribozyme above, an expression vector having nucleic acid encoding this ribozyme in a manner which allows expression of the ribozyme within a cell, and a cell including such an expression vector. Other aspects also include an expression vector where the ribozyme encoded by the vector is capable of cleaving a separate RNA substrate molecule

selected from a group consisting of viral RNA, messenger RNA, pathogenic RNA and cellular RNA.

In further related aspects, the invention features a method for cleaving a single-stranded RNA substrate at a cleavage site by causing base-pairing of the RNA substrate with a nucleic acid molecule only 3' of the cleavage site (Figure 7). Such a method includes contacting the RNA substrate with a nucleic acid molecule having an RNA substrate cleaving enzymatic activity which cleaves a separate RNA substrate at a cleavage site. This nucleic acid molecule includes an RNA substrate binding portion, which base pairs with the RNA substrate only 3' of the cleavage site, and an enzymatic portion (which may include a part or all of the RNA substrate binding portion) having the enzymatic activity. The nucleic acid molecule is able to base pair with the RNA substrate only 3' of the cleavage site, and causes cleavage of the RNA substrate at the cleavage site. The contacting is performed under conditions in which the nucleic acid molecule causes cleavage of the RNA substrate at the cleavage site.

In preferred embodiments of the above aspects, the nucleic acid molecule is derived from *Neurospora* VS RNA; the nucleic acid molecule is active to cleave 5' to the RNA duplex substrate (Fig. 6) of sequence 5'-AAGGGCGUCGUCGCCCCGA, or 5'-NNNNNNNNNNNNNNNNNNNN, where each N independently can be any specified nucleotide base, where the sequence forms at least 2 base-pair duplex structure; the nucleic acid molecule is RNA; the nucleic acid is a mixture of ribo and deoxyribonucleotides; the nucleic acid contains at least one nucleotide-containing modifications of sugar, phosphate and/or base or combinations thereof; the nucleic acid molecule may or contain abasic and/or non-nucleotide substitutions; the nucleic acid molecule contacts the target RNA sequence; the nucleic acid molecule is circular; and the nucleic acid molecule is active to cut a single-stranded RNA (Fig.

7) 5' to the sequence AAGGGCG or NNNNNNN or AAGGGCGUCGUC  
or NNNNNNNNNNNN where each N independently can be any  
specified nucleotide base, where the sequence forms at  
least 2 base-pairs with a complementary sequence in the 5'  
5 region of the enzymatic nucleic acid molecule, where the  
substrate RNA has at least one nucleotide 5' of the  
cleavage site.

By "derived" is meant that the enzymatic portion of  
the proposed "I" ribozyme is essentially the sequence  
10 shown in Fig. 5A and 6A.

In yet another preferred embodiment, the nucleic acid  
molecule derived from *Neurospora* VS RNA contacts a  
separate RNA duplex substrate molecule via base-paired  
interactions (Fig. 8 and 9) and causes cleavage of the  
15 duplex substrate RNA at the cleavage site. This  
interaction improves the specificity of the RNA cleavage  
reaction.

In another aspect, the invention features synthesis  
and assembly of enzymatic nucleic acid in one or more  
20 pieces, where the nucleic acid contacts a separate  
substrate RNA molecule and cleaves the substrate RNA at  
the cleavage site.

In yet another aspect, the invention features a  
circular nucleic acid molecule having an enzymatic  
25 activity which cleaves a separate RNA substrate at a  
cleavage site. The circular nucleic acids can be  
constructed using one of the methods described in the art  
(e.g., Been et al., WO 93/14218; Puttaraju et al., 1993  
*Nucleic Acids Res.* 21, 4253, Blumenfeld et al., WO  
30 93/05157).

Other features and advantages of the invention will be  
apparent from the following description of the preferred  
embodiments thereof, and from the claims.

Description of the Preferred Embodiments

The drawings will first briefly be described.

Drawings

Figure 1 is a diagrammatic representation of a hammerhead ribozyme domain known in the art. Stem II can be  $\geq 2$  base-pair long, or can even lack base pairs and consist of a loop region.

Figure 2a is a diagrammatic representation of the hammerhead ribozyme domain known in the art; Figure 2b is a diagrammatic representation of the hammerhead ribozyme as divided by Uhlenbeck (1987, *Nature*, 327, 596) into a substrate and enzyme portion; Figure 2c is a similar diagram showing the hammerhead divided by Haseloff and Gerlach (1988, *Nature*, 334, 585) into two portions; and Figure 2d is a similar diagram showing the hammerhead divided by Jeffries and Symons (1989, *Nucleic Acids Res.*, 17, 1371) into two portions.

Figure 3 is a diagrammatic representation of the general structure of a hairpin ribozyme. Helix 2 (H2) is provided with a least 4 base pairs (*i.e.*,  $n$  is 1, 2, 3 or 4) and helix 5 can be optionally provided of length 2 or more bases (preferably 3 - 20 bases, *i.e.*,  $m$  is from 1 - 20 or more). Helix 2 and helix 5 may be covalently linked by one or more bases (*i.e.*,  $r$  is  $\geq 1$  base). Helix 1, 4 or 5 may also be extended by 2 or more base pairs (*e.g.*, 4 - 20 base pairs) to stabilize the ribozyme structure, and preferably is a protein binding site. In each instance, each  $N$  and  $N'$  independently is any normal or modified base and each dash represents a potential base-pairing interaction. These nucleotides may be modified at the sugar, base or phosphate. Complete base-pairing is not required in the helices, but is preferred. Helix 1 and 4 can be of any size (*i.e.*,  $o$  and  $p$  is each independently from 0 to any number, *e.g.*, 20) as long as some base-pairing is maintained. Essential bases are shown as

specific bases in the structure, but those in the art will recognize that one or more may be modified chemically (abasic, base, sugar and/or phosphate modifications) or replaced with another base without significant effect.

5 Helix 4 can be formed from two separate molecules, i.e., without a connecting loop. The connecting loop when present may be a ribonucleotide with or without modifications to its base, sugar or phosphate. "q" is  $\geq$  2 bases. The connecting loop can also be replaced with a

10 non-nucleotide linker molecule. H, refers to bases A, U or C. Y refers to pyrimidine bases. " — " refers to a chemical bond.

Figure 4 is a representation of the general structure of the hepatitis delta virus ribozyme domain known in the

15 art (Perrotta and Been, 1991 *supra*).

Figure 5 A is a representation of the general structure of the self-cleaving *Neurospora* VS RNA domain. B is a line diagram representing the "I" ribozyme motif. The figure shows the "Upper" and the "Lower" base-paired

20 regions linked by the "connecting" region. IV (left) and V (right) shows the left and the right handed regions within the "upper" region, respectively. II (left) and VI (right) shows the left and the right handed regions within the "lower" region, respectively).

Figure 6 is a diagrammatic representation of a trans-cleaving VS RNA enzyme catalyzed cleavage of a double-stranded duplex RNA. A) Stem I is an intramolecular helix formed within the substrate RNA. Stems II through VI are intramolecular helices formed within the ribozyme. B)

30 schematic representation of minimal substrate sequence requirement for cleavage by the "I" ribozyme. N, refers to any base. N' refers to any base that is complementary to N. Y, refers to a pyrimidine.

Figure 7 is a diagrammatic representation of a trans-cleaving VS RNA enzyme catalyzed cleavage of a single-

35

stranded RNA. A) Stem I is an intermolecular helix formed between the substrate RNA and the ribozyme. Stems II through VI are intramolecular helices formed within the ribozyme. B) An alternate strategy to facilitate cleavage of a single-stranded RNA by the "I" ribozyme.

Figure 8 is a diagrammatic representation of the VS self-cleaving RNA. Base-paired interactions between nucleotides in the loop 1 (G630, U631 and C632) with complementary nucleotides in loop 5 (C699, A698 and G697) is shown as bold lines.

Figure 9 is an enlarged view of the interaction between loop 1 and loop V. A) shows base-pairing of G630 with C699, U631 with A698 and C632 and G697. B) shows base-paired interaction between nucleotides in loop 1 with nucleotides in loop V, where N can be any base (e.g., A, U, G, C) and N' can be any base that is complementary to N.

By "complementary" is meant a nucleotide sequence that can form hydrogen bond(s) with other nucleotide sequence by either traditional Watson-Crick or other non-traditional types (for example Hoogsteen type) of base-paired interactions.

Figure 10 shows the time course of double-stranded (ds) RNA cleavage by the VS RNA. A plot of fraction of substrate RNA cleaved as a function of time is shown.

Figure 11 shows the rate of RNA cleavage by the VS ribozyme as a function of ribozyme concentration.

Figure 12 shows the effect of temperature variation on the RNA cleavage reaction catalyzed by the VS ribozyme.

Figure 13 shows the effect of pH on RNA cleavage reaction catalyzed by the VS ribozyme.

Figure 14 shows the effect of spermidine concentration on the RNA cleavage reaction catalyzed by the VS ribozyme.

Figure 15 shows the effect of  $Mg^{2+}$  concentration on RNA cleavage reaction catalyzed by the VS ribozyme.

5        Figure 16 shows the kinetics of RNA cleavage reaction  
catalyzed by the VS ribozyme. A) Effect of ribozyme  
concentration on the *trans*-cleavage reaction under optimum  
reaction conditions. B) Effect of substrate RNA  
concentration on the *trans*-cleavage reaction under optimum  
10        reaction conditions.

Figure 17 shows enhancement of RNA cleavage reaction  
catalyzed by the VS ribozyme. Numbers 0, 5, and 30 min  
refers to the length of pre-incubation of VS RNA with 100  
mM viomycin prior to the initiation of RNA catalysis. -  
15        viomycin refers to RNA catalysis in the absence of  
viomycin.

Figure 18 shows viomycin-dependent reduction in the  
concentration of magnesium chloride required for  
catalysis.

20        Target sites

Targets for useful ribozymes can be determined as  
disclosed in Draper et al . WO 93/23569, Sullivan et al.,  
WO 94/02595 as well as by Draper et al., "Method and  
reagent for treatment of arthritic conditions U.S.S.N.  
25        08/152,487, filed 11/12/93, and hereby incorporated by  
reference herein in totality. Rather than repeat the  
guidance provided in those documents here, below are  
provided specific examples, not limiting to those in the  
art. Ribozymes to such targets are designed generally as  
30        described in those applications and synthesized to be  
tested *in vitro* and *in vivo*, as also described. Such  
ribozymes can also be optimized and delivered as described  
therein.

Ribozyme activity can be optimized by chemically synthesizing ribozymes with modifications that prevent their degradation by serum ribonucleases, modifications which enhance their efficacy in cells, and removal of  
5 helix-containing bases to shorten RNA synthesis times and reduce chemical requirements. See e.g., Eckstein et al., International Publication No. WO 92/07065; Perrault 1990 et al., *Nature* 344:565; Pieken et al., 1991 *Science* 253:314; Usman and Cedergren, 1992 *Trends in Biochem. Sci.*  
10 17:334; Usman et al., International Publication No. WO 93/15187; and Rossi et al., International Publication No. WO 91/03162, as well as Usman, N. et al. *US Patent Application* 07/829,729, and Sproat, B. *European Patent Application* 92110298.4 ;Chowrira and Burke, 1992 *supra*;  
15 Chowrira et al., 1993 *J. Biol. Chem.* 268, 19458, which describe various chemical modifications that can be made to the sugar moieties of enzymatic RNA molecules. All these publications are hereby incorporated by reference herein.

20 Ribozymes are added directly, or can be complexed with cationic lipids, packaged within liposomes, or otherwise delivered to target cells. The RNA or RNA complexes can be locally administered to relevant tissues *ex vivo*, or *in vivo* through injection, aerosol inhalation, infusion pump  
25 or stent, with or without their incorporation in biopolymers.

Sullivan, et al., *supra*, describes the general methods for delivery of enzymatic RNA molecules. Ribozymes may be administered to cells by a variety of methods known to  
30 those familiar to the art, including, but not restricted to, encapsulation in liposomes, by iontophoresis, or by incorporation into other vehicles, such as hydrogels, cyclodextrins, biodegradable nanocapsules, and bioadhesive microspheres. For some indications, ribozymes may be  
35 directly delivered *ex vivo* to cells or tissues with or without the aforementioned vehicles. Alternatively, the

RNA/vehicle combination is locally delivered by direct injection or by use of a catheter, infusion pump or stent. Other routes of delivery include, but are not limited to, intravascular, intramuscular, subcutaneous or joint injection, aerosol inhalation, oral (tablet or pill form), topical, systemic, ocular, intraperitoneal and/or intrathecal delivery. More detailed descriptions of ribozyme delivery and administration are provided in Sullivan, et al., *supra* and Draper, et al., *supra* which have been incorporated by reference herein.

Another means of accumulating high concentrations of a ribozyme(s) within cells is to incorporate the ribozyme-encoding sequences into a DNA expression vector. Transcription of the ribozyme sequences are driven from a promoter for eukaryotic RNA polymerase I (pol I), RNA polymerase II (pol II), or RNA polymerase III (pol III). Transcripts from pol II or pol III promoters will be expressed at high levels in all cells; the levels of a given pol II promoter in a given cell type will depend on the nature of the gene regulatory sequences (enhancers, silencers, etc.) present nearby. Prokaryotic RNA polymerase promoters are also used, providing that the prokaryotic RNA polymerase enzyme is expressed in the appropriate cells (Elroy-Stein, O. and Moss, B., 1990, *Proc. Natl. Acad. Sci. U S A*, 87, 6743-7; Gao, X. and Huang, L., 1993, *Nucleic Acids Res.*, 21, 2867-72; Lieber, A., et al., 1993, *Methods Enzymol.*, 217, 47-66; Zhou, Y., et al., 1990, *Mol. Cell. Biol.*, 10, 4529-37). Several investigators have demonstrated that ribozymes expressed from such promoters can function in mammalian cells (e.g. Kashani-Sabet, M., et al., 1992, *Antisense Res. Dev.*, 2, 3-15; Ojwang, J. O., et al., 1992, *Proc. Natl. Acad. Sci. U S A*, 89, 10802-6; Chen, C. J., et al., 1992, *Nucleic Acids Res.*, 20, 4581-9; Yu, M., et al., 1993, *Proc. Natl. Acad. Sci. U S A*, 90, 6340-4; L'Huillier, P. J., et al., 1992, *EMBO J.*, 11, 4411-8; Lisziewicz, J., et al., 1993, *Proc. Natl. Acad. Sci. U. S. A.*, 90, 8000-

4)) .The activity of such ribozymes can be augmented by their release from the primary transcript by a second ribozyme (Draper et al., PCT WO93/23569, and Sullivan et al., PCT WO94/02595, both hereby incorporated in their  
5 totality by reference herein; Ohkawa et al., 1992 *Nucleic Acids Symp. Ser.*, 27, 15-6; Taira et al., 1991, *Nucleic Acids Res.*, 19, 5125-30; Ventura et al., 1993 *Nucleic Acids Res.*, 21, 3249-55; Chowrira et al., 1994 *J. Biol. Chem.* 269, 25856). The above ribozyme transcription units  
10 can be incorporated into a variety of vectors for introduction into mammalian cells, including but not restricted to, plasmid DNA vectors, viral DNA vectors (such as adenovirus or adeno-associated vectors), or viral RNA vectors (such as retroviral and alpha virus vectors).

15 In a preferred embodiment of the invention, a transcription unit expressing an "I" ribozyme that cleaves target RNA is inserted into a plasmid DNA vector or an adenovirus or adeno-associated DNA viral or retroviral vector. Viral vectors have been used to transfer genes to  
20 the lung and these vectors lead to transient gene expression (Zabner et al., 1993 *Cell* 75, 207; Carter, 1992 *Curr. Opi. Biotech.* 3, 533) and both vectors lead to transient gene expression. The adenovirus vector is delivered as recombinant adenoviral particles. DNA may be  
25 delivered alone or complexed with vehicles (as described for RNA above). The DNA, DNA/vehicle complexes, or the recombinant adenovirus particles are locally administered to the site of treatment, e.g., through the use of an injection catheter, stent or infusion pump or are directly  
30 added to cells or tissues *ex vivo*.

In another aspect of the invention, ribozymes that cleave target molecules are expressed from transcription units inserted into DNA or RNA vectors. The recombinant vectors are preferably DNA plasmids or viral vectors.  
35 Ribozyme expressing viral vectors could be constructed based on, but not limited to, adeno-associated virus,

retrovirus, adenovirus, or alphavirus. Preferably, the recombinant vectors capable of expressing the ribozymes are locally delivered as described above, and persist in target cells. Alternatively, viral vectors may be used that provide for transient expression of ribozymes. Such vectors might be repeatedly administered as necessary. Once expressed, the ribozymes cleave the target mRNA. Delivery of ribozyme expressing vectors could be systemic, such as by intravenous or intramuscular administration, by administration to target cells ex-planted from the patient followed by reintroduction into the patient, or by any other means that would allow for introduction into the desired target cell.

Thus, ribozymes of the present invention that cleave target mRNA and thereby inhibit and/or reduce target activity have many potential therapeutic uses, and there are reasonable modes of delivering the ribozymes in a number of the possible indications. Development of an effective ribozyme that inhibits specific function are described in the art.

By "inhibit" is meant that the activity or level of target RNA is reduced below that observed in the absence of the ribozyme, and preferably is below that level observed in the presence of an inactive RNA molecule able to bind to the same site on the RNA, but unable to cleave that RNA.

By "vectors" is meant any nucleic acid- and/or viral-based technique used to deliver a desired nucleic acid.

#### Examples

The following materials and methods were used in the following examples:

Clones and site-directed mutagenesis.

Clone G11 has been described previously (Guo et al., 1993 *J. Mol. Biol.* 232, 351) and contains bases 617 to 881 of VS RNA in vector pTZ19R. Mutations were made in clone  
5 G11 or DG11 (from which the *ScaI*, *AvaI*, *AcyI* sites in the vector had been destroyed to facilitate future subcloning by retaining only a unique site for each enzyme within the VS sequence). Substitutions on the 5' or 3' side of a  
10 helix were made by oligonucleotide directed mutagenesis (Kunkel et al., 1987 in *Methods Enzymol.* eds. Wu and Grossman, vol. 154, pp. 367, Academic Press, San Diego, CA.); compensatory mutants were also made this way unless a unique restriction site separated the 5' and 3' mutations, in which case recombinant DNA techniques were  
15 used to combine the two mutations into a single clone. Usually two separate isolates of each mutant were identified and sequenced from the T7 promoter to the *SspI* site which was the 3' end of the run-off transcripts used to measure cleavage rates.

20 Measurement of self-cleavage rates:

RNAs were synthesized by T7 transcription from plasmid templates linearized with *SspI* (VS RNA nt 783). Uncleaved precursor RNAs were obtained from wild type and active  
25 mutants using decreased magnesium concentrations during transcription (Collins and Olive, 1993 *Biochemistry* 32, 2795). Transcription reactions were extracted once each with phenol/Chloroform.Isoamyl Alcohol (CIA) and once with CIA and precipitated with ethanol. RNAs (approximately 50 nM) were dissolved in water, preincubated at 37°C, and  
30 mixed with one fifth volume of 5X buffer (final concentrations: 50 mM Tris-HCl pH 8.0, 50 mM KCl, 2 mM spermidine, 10 mM MgCl<sub>2</sub>). Aliquots were removed at various times, the precursor and product RNAs separated by electrophoresis and quantitated using a PhosphorImager as  
35 described previously (Collins and Olive, *supra*). First-

order self-cleavage rates were determined from the slopes of plots of fraction of uncleaved RNA versus time.

Site-Directed mutagenesis:

Applicant constructed site-directed base substitution mutants that would be predicted to disrupt helices by changing one or more bases on the 5' or 3' side of predicted helices. Compensatory mutations that would restore a helix, but using a different base pair, were also constructed. Self-cleavage rates were measured for wild-type, the 5' and 3' mutants, and the compensatory mutant, denoted 5'3'. The data for representative mutants are shown in Table 2.

DNA templates and synthesis of RNAs:

Fragments of VS DNA were cloned into vectors pTZ18R or 19R (Pharmacia). Clone G11 (see Guo *et al.*, 1993 *supra*) contains VS nts 617 to 881 numbered as in Saville and Collins (1990 *Cell* 61, 685); the cleavage site is between nucleotides G620 and A621. Substrate RNAs were transcribed (see below) from G11 or its derivatives which had been linearized at the *Ava*I site (nucleotide 639) or the *Ssp*I site (nucleotide 783) to make RNAs designated G11/*Ava* and G11/*Ssp*, respectively. These RNAs begin with nine vector nts (5'gggaaagcu; see Figure 5) followed by VS sequence. A site-directed mutant of G11, clone 621U which contains a single A to U substitution immediately following the self-cleavage site, was also used.

Clone A-3 contains VS sequences downstream of the *Ava*I site (nts. 640-881) in a derivative of pTZ19R that lacks the *Xba*I and *Sph*I sites in the multiple cloning site (constructed for reasons unrelated to the project described here). Transcripts of clone A-3 digested with *Ssp*I (VS nucleotide 783) begin with 9 vector nucleotides (5'GGGAAAGCU) followed by 144 nucleotides of VS RNA; this RNA is designated the *Ava* ribozyme, or Rz.

5 RNAs were prepared by *in vitro* Bacteriophage T7 RNA polymerase transcription from linearized plasmid DNAs. Transcription reactions (usually 300  $\mu$ l) contained 10 to 20  $\mu$ g of appropriately linearized template, 1 mM of each NTP (Pharmacia), 5 mM dithiothreitol, 1X T7 polymerase buffer (Bethesda Research Laboratories: 40 mM Tris-HCl pH 8.0; 8 mM MgCl<sub>2</sub>; 25 mM NaCl; 2 mM spermidine-HCl<sub>3</sub>), 300 U RNAGuard (Pharmacia), 150 to 200 Units T7 RNA polymerase (Bethesda Research Laboratories) for 2 hrs at 37°C.

10 Radioactive transcripts were prepared as above except an additional 30 mCi of [ $\alpha$ -<sup>32</sup>P] GTP (or, for specific experiments, ATP or UTP) was added. Samples were subsequently treated with DNase I (Pharmacia; 5 U/ $\mu$ g DNA template) for 15 minutes, then EDTA was added to 10 mM.

15 RNAs were extracted with phenol: chloroform: isoamyl alcohol, chloroform:isoamyl alcohol (CIA) and ethanol precipitated in the presence of 0.3 M sodium acetate, pH 5.2.

20 Precipitated RNAs were dissolved in water and two volumes of sequencing dye (95% formamide, 0.5X TBE, 0.1% xylene cyanol, 0.1% bromphenol blue), heated at 75°C for 3 min, and fractionated by electrophoresis on denaturing polyacrylamide gels (40:1 acrylamide:bis-acrylamide) of appropriate concentration containing 8.3 M urea and 1X TBE

25 (135 mM Tris, 45 mM boric acid, 2.5 mM EDTA). RNAs were visualized either by autoradiography or UV shadowing. Bands of interest were excised, eluted overnight at 4°C in water and filtered to remove residual polyacrylamide.

30 RNAs were precipitated with ethanol in the presence of 0.3 M sodium acetate and dissolved in water. Concentrations were determined spectrophotometrically, assuming 1 OD<sub>260</sub> to correspond to an RNA concentration of 40 mg/ml.

#### End-labeling of RNAs:

35 RNAs were labeled at 5' termini using T4 polynucleotide kinase and [ $\gamma$ -<sup>32</sup>P] ATP or at 3' termini using T4 RNA ligase and 5' [<sup>32</sup>P] pCp. End-labeled RNAs

were fractionated on denaturing polyacrylamide gels and detected by autoradiography.

In order to remove 5' triphosphates prior to 5' end labeling, some RNAs were treated with 1 U calf intestinal alkaline phosphatase (Boehringer Mannheim) in a 10  $\mu$ l reaction containing 50 mM Tris-HCl pH 8.0, 0.1 mM EDTA at 55°C for 30 min. Reactions were terminated by extraction with phenol:CIA and CIA.

Trans-cleavage reactions:

10        *Trans*-cleavage of substrate RNA (S) by the *Ava* ribozyme (Rz) was carried out following pre-incubation of gel-purified S and Rz in the appropriate 1X reaction solution for 2 min. Reactions were initiated by addition of ribozyme to substrate in a final volume of 20  $\mu$ l. In a  
15        typical reaction, 10 aliquots of 1.5  $\mu$ l were removed at specified times, terminated by addition of 13.5  $\mu$ l of stop mix (70% formamide, 7 mM EDTA, 0.4x TBE, 0.07% xylene cyanol, and 0.07% bromphenol blue) and stored on ice. Samples were fractionated by electrophoresis on denaturing  
20        20% polyacrylamide gels.

The effects of temperature, pH, MgCl<sub>2</sub> and spermidine-(HCl)<sub>3</sub> on the *trans*-cleavage reaction were analyzed by incubating equimolar concentrations of Rz and S (0.05  $\mu$ M each) in solutions described in the figure legends. A  
25        final study of the effects of MgCl<sub>2</sub> under otherwise "optimized" conditions was performed at 30°C, 50 mM Tris-HCl pH 8.0, 2 mM spermidine, 25 mM KCl.

Experiments to establish single-turnover conditions (Fig. 10) were performed at 30°C in 50 mM Tris-HCl pH 7.1,  
30        25 mM MgCl<sub>2</sub>, 25 mM KCl, 2 mM spermidine. Analyses of the effect of pH under single turnover conditions (Fig. 13) were performed as above, except the concentrations of Rz and S were 5  $\mu$ M and 0.13  $\mu$ M, respectively. 50 mM Tris-HCl was used for pHs 7.1 to 8.9; 16.5 mM PIPES/44 mM Tris was  
35        used for pH 6.

Amounts of substrate and products were quantitated using a PhosphorImager" and ImageQuant" version 3.0 software (Molecular Dynamics, Sunnyvale, CA, USA). Estimates of initial cleavage rates were derived from  
5 plots of fraction of substrate cleaved vs. time using Grafit software (Erithacus Software Ltd, Staines, U.K). Up to 90% of the substrate could be cleaved in 60 minutes at approximately equimolar concentration of ribozyme, with the curve indicating the presence of approximately 10%  
10 unreactive starting material. Curves were not adjusted to 100% completion, and the nature of the unreactive substrate has not been characterized further.

Example 1: Mutational analysis of the self-cleaving VS RNA

15 As a starting point for structure prediction, applicant used the MFOLD program of Zuker and collaborators (Zuker, 1989 *Science* 244, 48) to obtain five major families of thermodynamically reasonable models for the minimal self-cleaving RNA. The models differed in the  
20 number or length of helices and/or the predicted pairing partners for a given region of the sequence, and ranged from the structure predicted to be most stable to sub-optimal foldings 10% less stable than the lowest free energy structure. Structures within this range of free  
25 energy have been found to predict the majority of helices in other RNAs (Jaegar et al., 1989 *Proc. Natl. Acad. Sci. USA* 86, 7706). These various structural models were tested by making use of site-directed mutagenesis.

30 Of the various models evaluated, that shown in Fig. 5A was the most consistent with the data from the cleavage activity of all of the mutants. In general, mutations on the 5' or 3' side of predicted helices II through VI inactivated the ribozyme or decreased activity well below that of the wild type sequence. Compensatory  
35 substitutions that restored a helix, but with a different base sequence, restored activity usually to that of wild

type or greater, but always to a level at least greater than that of the individual 5' or 3' mutants. These data showed that regions of each of these helices perform roles that are not sequence-specific but are presumably involved in proper folding of the RNA.

In some cases, mutations on the 5' and 3' side did not reduce activity to the same extent. For example, mutant Va5' shows essentially no activity, but Va3' retains more than half the activity of wild type. It may be that the particular substitutions chosen did not disrupt the helix equally well or that one of the bases makes a specific contribution to local or tertiary structure (Cech, 1988 *Gene* 73, 259).

At some positions activity could not be restored by the compensatory substitutions attempted, even though restoration was possible at other positions in the same helix. This was especially common at predicted base pairs adjacent to natural disruptions in a helix, such as the unpaired adenosines at positions 652 and 718 (Table 2; e.g., positions IIc and IIIc). Mutant G653C showed no activity, as did each of the three substitutions at the predicted complementary position C771; the double mutant G653C:C771G showed some restoration of activity, but was still 10-fold slower than wild type (mutant IIc). Similarly, the A661:U717 pair immediately above unpaired A718 could not be replaced by a U:A (mutant IIIc), even though the next pair, C662:G716, could be substituted by a G:C (mutant IIIb). Deletion of either unpaired adenosine also decreased activity, severely so in the case of A652. These observations suggest that specific local structures may be especially important in these areas, or that some of these bases may be involved in alternative and/or additional interactions.

The structure and sequence requirements of Helix I appear to be more complex than implied by the model in Fig. 5. Although several base substitutions decreased

activity severely (e.g., mutants Ia5', Ic3'), other mutations that might be expected to have an equally disruptive effect on the helix (mutants Ia3', Ib3', Ic5') decreased activity only slightly. We have not found any positions at which the compensatory substitutions that we have tried restored activity much above the level of the individual mutants. This may result in part from the stem of five G-C pairs, possibly extended by non-Watson-Crick interactions, which would be predicted to be very stable. This existence and stability of helix I is supported by chemical structure probing and difficulties in sequencing this region. Taken together, these observations suggest that certain bases in helix I may be involved in alternative secondary structures or tertiary interactions that are crucial for activity.

Based on the above data, applicant has constructed a model for the secondary structure of the VS self-cleaving RNA, which contains the minimal contiguous region of VS RNA required for self-cleavage. In five of the six helices proposed in the model, site directed base substitution mutations that disrupt the helix decrease or eliminate activity. Compensatory substitutions restore activity, usually to wild type level or even greater. These data provide strong support for a sequence-independent, presumably structural, role for portions of these five helices.

Several observations suggest that the formation of the active structure is more complicated than implied above. While site directed mutants of helices II through VI indicate that portions of these helices play a sequence-independent structural role, mutants in helix I show a more complex pattern. Mutations at certain positions in helix I inactivated the ribozyme but compensatory substitutions did not restore activity. Furthermore, there is evidence from site-directed mutagenesis and compensating substitutions for a tertiary interaction that

requires the unwinding of at least the top base pair in helix I (G628:C632), to allow an interaction with loop V (see Figure 8 and 9). Taken together, these observations suggest that a substantial conformational change may occur  
5 in helix I under native conditions. The model predicts that VS RNA contains some structural features found or predicted in other RNAs. The GUA tetraloop capping helix VI is an example of a GNRA loop that is common in rRNAs (Woese et al., 1990 *Proc. natl. Acad. Sci. USA* 87, 8467)  
10 and contains internal hydrogen bond and stacking interactions that stabilize the loop structure (Heus and Pardi, 1991 *Science* 253, 191; Santa-Lucia et al., 1992 *Science* 256, 217).

The secondary structure of VS RNA is different from  
15 the hammerhead and hairpin ribozymes in that, although a short helix upstream of the site of cleavage could form in VS RNA, it is not required for activity (Guo et al., 1993 *supra*) as it is in these two ribozymes (Foster and Symons, 1987 *Cell* 50, 9; Berzal-Herranz et al., 1993 *EMBO.J.* 12, 2567). Also, VS RNA does not contain the set of bases  
20 known to be important for activity of hammerhead (Symon, 1992 *Ann. Rev. Biochem.* 61, 641) or hairpin (Berzal-Herranz et al., *supra*) ribozymes. Like VS RNA, the HDV ribozyme (Been, 1994 *TIBS* 19, 251) requires only a single  
25 nucleotide upstream of the cleavage site, and a GC-rich helix is found downstream of the cleavage site in both ribozymes. Beyond these similarities, however, the secondary structures have nothing in common.

30 Example 2: Trans-cleavage reaction catalyzed by the VS RNA.

The trans-reaction described below was constructed using various restriction fragments of VS DNA cloned in a T7 promoter vector to construct pairs of non-overlapping regions of VS RNA. One member of each pair, the substrate  
35 (S), contained the expected cleavage site, following nucleotide G620 (numbered as in Saville and Collins, 1990

*supra*); the other, the enzyme or ribozyme (Rz), contained the remainder of the VS sequence, terminating at the *SspI* site at nucleotide 783. In preliminary experiments these transcripts were mixed at approximately 1:1 ratio and  
5 incubated under conditions known to support self-cleavage (Collins and Olive, 1993 *supra*). Most combinations showed little or no cleavage; however, almost complete cleavage of a 32 nucleotide substrate RNA that terminates at the  
10 *AvaI* site (nucleotide 639) was observed during a one hour incubation with a ribozyme that begins at the *AvaI* site and ends at the *SspI* site (nucleotide 783); no cleavage was observed in the absence of ribozyme. The electrophoretic mobility of the two cleavage products were approximately those expected for cleavage after nucleotide  
15 620, which is the site of intramolecular self-cleavage of VS RNA. Applicant chose to examine this *trans*-cleavage reaction in further detail.

Example 3: *Trans*-cleavage occurs at the same site as self-cleavage

20 To determine the precise site of cleavage, G11/*Ava* substrate, P1 and P2 were labeled at their 5' ends and sequenced by partial enzymatic digestion using RNases T1 or U2. Cleavage products of a mutant substrate containing  
25 a single base substitution 3' of the cleavage site (A621U) were also characterized to resolve possible ambiguities due to anomalous migration of some bands. Because the substrate and P1 are identical in sequence from the 5' end to the cleavage site, all RNase sequencing bands  
30 comigrated, as expected. Full length P1 comigrated with the 13 nucleotide RNase T1 fragment of G11/*Ava* that terminates at G620, which is the site of intramolecular self-cleavage in VS RNA. Also the 3' end of P1 was found to be guanosine 2'3' cyclic phosphate, indicating that  
35 both the location and chemical pathway of *trans* cleavage are the same as in the self-cleavage reaction.

As expected from the finding of a cyclic phosphate at the 3' end of P1, a 5' hydroxyl group was found at the 5' end of P2, as evidenced by its end-labeling by [ $\gamma$ - $^{32}$ P] ATP and T4 polynucleotide kinase without prior phosphatase treatment. Alkaline hydrolysis ladders of 5' end-labeled P2 contained only 18 of the expected 19 bands. This is the result of a compression artifact involving the formation of a very stable stem-loop structure in the longer RNAs; this is described in detail below. Nonetheless, the 5' terminal nucleotides of P2 derived from cleavage of G11/Ava S and the A621U mutant were A and U, respectively, confirming that cleavage occurred between nts 620 and 621, as in the self-cleavage reaction.

Example 4: Minimal length of the substrate RNA

To determine the minimal sequence required downstream of the cleavage site, applicant used essentially the approach described by Forster and Symons (1987 *supra*). 5' end-labeled G11/Ssp RNA was partially hydrolyzed by treatment at high pH, then incubated with or without the ribozyme. Incubation in the absence of ribozyme confirmed applicant's previous finding that full length G11/Ssp RNA and deletion derivatives lacking ten or fewer nucleotides at the 3' end can self-cleave (Guo et al., 1993 *supra*). Incubation with the ribozyme resulted in the disappearance, or at least decrease in intensity, of bands corresponding to RNAs terminating at nucleotide 639 or longer. A few RNAs were not cleaved to completion under these conditions, indicating that they are relatively poorer substrates. The minimal length substrate terminates at residue 639, which by coincidence corresponds precisely to the RNA used in Fig. 6, which was synthesized by runoff transcription of a template linearized at the *Ava*I site. Thus only 19 nucleotides downstream of the cleavage site are required for *trans*-cleavage by the *Ava* ribozyme.

A parallel experiment using 3' end-labeled RNA showed that only a single nucleotide upstream of the cleavage site is required for *trans*-cleavage. Taken together with the results from 5' end labeled RNA, these data show that the minimum contiguous region of the native RNA required for *trans*-cleavage consists of one nucleotide upstream of the cleavage site and 19 nucleotides downstream.

Example 5: The minimal substrate RNA consists mostly of a hairpin loop

RNA structure prediction using the MFOLD program of Zuker and collaborators (Zuker, 1989 *supra*) suggests that the most thermodynamically reasonable structure of the substrate RNA would be the hairpin-containing structure drawn in Fig. 6. During the characterization of the *trans*-cleavage products applicant noted several observations that were consistent with such a structure. P2 migrated faster than expected relative to size markers for a 19 nucleotide RNA, suggesting that it contained a structure that was not fully denatured even in a gel containing 8.3 M urea. Certain guanosine (623-625, 627 and 633) and adenosine (621 and 622) residues in S and P2 were cleaved weakly or not at all by RNases T1 and/or U2, even though sequencing reactions were performed under putatively denaturing conditions of 50°C, 1 mM EDTA and 7 M urea. Only 18 of the expected 19 bands were observed in the 5' end-labeled partial alkaline hydrolysis products of P2.

Example 6: Biochemical Characteristics of the *Trans*-Cleavage Reaction Conditions:

Applicant has investigated the effects of several variables that would be expected to affect RNA structure and that have been found to affect the cleavage rates of other ribozymes. An equimolar ratio of S and Rz (0.05  $\mu$ M each) for most initial investigations was used; more detailed analysis specifically under either steady-state or single-turnover conditions is described below.

Cleavage rate increased with temperature until an optimum was reached around 30°C, and then decreased sharply above 40°C (Fig. 12). No reaction was observed in the absence of a divalent cation, and reaction rate increased with increasing MgCl<sub>2</sub>, reaching a maximum around 100 mM, when magnesium was the only cation present. To determine whether some of the MgCl<sub>2</sub> was acting simply as a structural counterion, the effects of spermidine (Fig. 14), NaCl, and KCl were investigated in the presence of a subsaturating concentration of MgCl<sub>2</sub> (10 mM). In the presence of 10 mM MgCl<sub>2</sub>, spermidine at 1 mM or greater enhanced the rate of cleavage nearly 10-fold compared to the same reaction without spermidine (Fig. 14). Low concentrations of KCl (< 100 mM) also stimulated the reaction rate up to about 10 fold. Perhaps surprisingly, NaCl had almost no effect. These observations are similar to the effects of cations observed previously on the rate of self-cleavage of VS RNA (Collins and Olive, 1993 *supra*).

The rate of reaction showed only a small pH dependence: the nearly 100-fold increase in the hydroxide concentration between pH 7.1 and 8.9 resulted in only a 2-fold increase in rate (Fig. 13). The effect of pH specifically under single turnover conditions is described below.

Finally, the effect of MgCl<sub>2</sub> was re-assayed under "optimized" reaction conditions containing 50 mM Tris, pH 8.0, 2 mM spermidine, 25 mM KCl, and incubated at 30°C (Fig. 15). Under these conditions 10 mM MgCl<sub>2</sub> allowed the same rate of cleavage as a reaction containing 70 mM MgCl<sub>2</sub> under suboptimal conditions. Thus, the combined effects of temperature, pH, and cations other than magnesium enhanced cleavage substantially. However, no reaction was observed in the absence of MgCl<sub>2</sub>, indicating that neither spermidine nor KCl can replace magnesium in cleavage.

Effects of pH under single turnover conditions:

The trans-cleavage reaction rate showed only a small pH dependence at equimolar concentrations of ribozyme and substrate (Fig. 13). However, these experiments were performed at subsaturating concentrations of MgCl<sub>2</sub> and they were probably not under single turnover conditions. Consequently it was possible that some step in the reaction other than the actual cleavage step itself may have been the rate limiting step, thereby masking the effect of increased hydroxide ion concentration. To investigate this possibility, single turnover conditions were established empirically under optimized reaction conditions by measuring the initial rates of trans-cleavage of 0.13 mM substrate by increasing concentrations of ribozyme. The initial rate of cleavage increased with ribozyme concentration up to about 2.5 mM, and subsequently leveled off, suggesting that the reaction was approaching single turnover conditions (Fig. 11). The cleavage rate as a function of concentration of MgCl<sub>2</sub> was re-investigated using 0.13 μM S and 5 μM Rz and found to be essentially the same shape as in Fig. 15; a concentration of 25 mM MgCl<sub>2</sub> was chosen to ensure that magnesium was not limiting. Trans-cleavage reactions using 0.13 μM substrate and 5 μM ribozyme over a range of pH showed only a minor enhancement in reaction rate.

Steady-state reaction kinetics:

To determine if the Ava ribozyme is capable of multiple turnover, Rz was incubated with approximately a 20-fold molar excess of S (Fig. 16). If each ribozyme molecule cleaved only a single substrate, a maximum of 1/20th of S could be cleaved. In contrast, we observed that cleavage continued at a constant rate until about 40% of S was cleaved, and then decreased slowly as the concentration of available uncleaved S decreased. This indicated that the Ava ribozyme behaved like a true enzyme, in that it was capable of multiple rounds of

cleavage. Also, as expected of an enzyme, the initial rate of cleavage was directly proportional to the concentration of the ribozyme under conditions of substrate excess (Fig. 16).

5 The *trans*-cleavage reaction exhibits a saturation curve with respect to substrate concentration that is typical of Michaelis-Menten kinetics (Fig. 16B). A  $K_M$  of 0.13  $\mu\text{M}$  and  $k_{\text{cat}}$  of 0.7  $\text{min}^{-1}$  were obtained from these data. These values have been observed to vary by about a  
10 factor of about two when experiments were repeated with different batches of ribozyme over a period of two years.

Applicant has modified the natural intramolecular self-cleavage reaction of VS RNA by constructing a ribozyme containing 144 nucleotides of VS RNA that is  
15 capable of an intermolecular *trans*-cleavage reaction. This ribozyme acts as a true enzyme in cleaving a 32 nucleotide substrate RNA. In the presence of excess substrate, the initial rate of cleavage is proportional to ribozyme concentration, and a single ribozyme molecule can  
20 cleave multiple substrate molecules. The ribozyme is specific in cleaving a single phosphodiester bond, the same one as cleaved in the natural self-cleavage reaction. The *trans*-cleavage reaction exhibits Michaelis-Menten kinetics, with  $K_m \approx 0.13 \mu\text{M}$  and  $k_{\text{cat}} \approx 0.7 \text{min}^{-1}$ . Fedor and Uhlenbeck (1990 *Proc. Natl. Acad. Sci. USA* 87, 168)  
25 have noted that  $K_{\text{cat}}$  values in the range of 1  $\text{min}^{-1}$  and  $K_M$  values in the nanomolar range are characteristic of many diverse ribozymes.

The shortest contiguous region of VS RNA that  
30 functions as a substrate for the ribozyme described here contains a single nucleotide upstream of the cleavage site and 19 nucleotides downstream. Applicants previous characterization of the intramolecular self-cleavage reaction also showed that only a single nucleotide is  
35 required upstream of the cleavage site (Guo *et al.*, 1993); in this respect, VS is similar to HDV ribozymes which also

require only a single upstream nucleotide for self- or trans-cleavage (Been, 1994 *supra*). The substrate consists mostly of a stem-loop structure flanked by three nucleotides on the 5' and 3' ends, some of which may be  
5 involved in non-Watson-Crick structure (Fig. 6). This conclusion is based on minimum free energy predictions, aberrant electrophoretic mobility and the pattern of accessibility to single-strand-specific nucleases. Disruption of some base pairs in the stem by certain  
10 single base substitutions has little or no effect on self-cleavage. However, at some positions the identity of one of the bases in a particular pair is critical: even when the compensating substitution is made in the complementary position to restore the helix, cleavage is not restored.  
15 Applicant believes that specific bases at specific positions are more important than simply the presence of a stem-loop structure.

The stem-loop structure of the VS substrate RNA leaves no long regions available for Watson-Crick pairing with  
20 the ribozyme. The secondary structure of the minimal self-cleaving VS RNA has been determined and a working model for the structure of the ribozyme has been proposed (Fig. 5). The ribozyme has no long (*i.e.*, more than 5 nucleotides) single-stranded regions. This is in contrast  
25 to most trans-acting ribozymes derived from hammerhead, hairpin, HDV and Group I intron RNAs, which have been designed to interact with single-stranded regions of their substrates via formation of one or two intermolecular helices flanking the site to be cleaved.

30 In addition to base-pairing, tertiary interactions are known or suspected to contribute to substrate binding of several ribozymes (Pyle et al., 1992 *Nature* 350, 628). In fact, tertiary interactions alone are sufficient to allow very weak ( $K_M > 0.1 \mu\text{M}$ ) but specific binding of the P1  
35 stem-loop of a Group I intron to its catalytic core (Doudna and Szostak, 1989 *Nature* 339, 519). RNase P also

recognizes substrates that contain substantial secondary structure and have very limited potential for Watson-Crick pairing with the ribozyme (Guerrier-Takada and Altman, 1993 *Biochemistry* 32, 7152).

5 We noted in our previous characterization of the VS RNA self-cleavage reaction that the cleavage rate was essentially unaffected by pH (Collins and Olive, 1993 *supra*). Consistent with this observation, the *trans*-cleavage reaction described here also showed little, if  
10 any, pH dependence, even when examined under single turnover conditions. These observations differ from results examining the rate of the chemical cleavage step of hammerhead ribozymes (Dahm et al., 1993 *Biochemistry* 32, 13040), RNase P (Guerrier-Takada et al., 1986  
15 *Biochemistry* 25, 1509; Smith and Pace, 1993 *Biochemistry* 32, 5273; Beebe and Fierke, 1994 *Biochemistry* 33, 10294) and *Tetrahymena* Group I intron (Herschlag et al., 1993 *Biochemistry* 32, 8312). For these ribozymes, the rate of the cleavage step was found to increase with increasing  
20 pH. Failure to observe pH dependence in VS RNA could mean that OH<sup>-</sup> is not involved in the cleavage reaction, that the reaction proceeds via a novel mechanism or, more likely, that the VS *trans* reaction is not limited by the rate of the chemical cleavage step under these conditions,  
25 but rather by some step that precedes actual cleavage.

One interesting candidate for such a rate-limiting step would be a conformational change in the substrate and/or ribozyme following binding. At saturating ribozyme concentration, the pseudo-first-order rate constant for  
30 *trans*-cleavage of S ( $\approx 0.6 \text{ min}^{-1}$ ) is about 10-fold higher than the rate of self-cleavage of G11 RNA under similar conditions (Collins and Olive, 1993 *supra*). Since we envision that the *trans*-cleavage reaction recreates essentially the same RNA conformation as in the self-  
35 cleavage reaction, the higher rate suggests that the cleavable conformation may be more easily attained when S

(stem-loop I; Fig. 5) is not constrained by covalent attachment to the ribozyme core. In support of this idea, we have also found that rate of self-cleavage of G11 RNA can be increased several fold by increasing the distance between stem-loop I and the ribozyme core. These observations are consistent with the idea of at least one conformational change involving the substrate stem-loop occurring during the reaction.

The temperature optimum of the *trans*-cleavage reaction is substantially lower than for the self-cleavage reaction (30°C vs ≈45°C) and activity drops off much more sharply at higher temperatures (Collins and Olive, 1993 *supra*). The retention of activity at higher temperatures in the self-cleavage reaction indicates that the active site of the ribozyme does not begin to denature until at least 45°C. The lower optimum temperature of the *trans*-cleavage reaction may reflect decreased binding of the substrate at higher temperatures.

The observation that the VS ribozyme can recognize a substrate that contains a stable secondary structure may be useful from the perspective of ribozyme engineering. Among the limitations to modifying hammerhead, hairpin or Group I intron ribozymes to cleave non-native target RNAs is the requirement that the target site be in a single-stranded region to allow recognition via base pairing with the ribozyme. Because the cleavage site for the VS ribozyme is adjacent to a stable secondary structure, the VS ribozyme may have unique properties that can be adapted to cleaving certain RNAs that are not accessible to the action of other ribozymes.

Example 7: Antibiotic-mediated enhancement of RNA Cleavage reaction catalyzed by the VS ribozyme

Several examples of inhibition of the function of a ribozyme or RNA-protein interaction have shown that certain antibiotics can interact specifically with RNA

(Yarus, 1988 *Science* 240, 1751; Schroeder et al., 1993 *Science* 260, 1443). Small peptide antibiotics like viomycin has been shown to inhibit reactions of certain RNA and RNA-protein complexes (Liou and Tanaka, 1976 *BBRC* 5 71, 477; Wank et al., 1993 *J. Mol. Biol.* 236, 1001).

Applicant has found that certain peptide antibiotics (e.g., viomycin) enhance RNA cleavage reactions catalyzed by the VS ribozyme. Antibiotics decrease, at least by an order of magnitude, the concentration of metal ions required for ribozyme activity. Additionally, viomycin facilitates inter-molecular interactions between VS RNA molecules.

Referring to Fig. 17, VS RNA are pre-incubated with 100 mM viomycin for 0, 1, 15 and 30 min prior to adding the reaction buffer (40 mM Tris-HCl pH 8.0; 50 mM KCl and 10 mM MgCl<sub>2</sub>). The reaction is carried out at 37°C and aliquots are taken out at regular intervals of time and the reaction is stopped by adding an equal volume of formamide stop buffer. The reaction products are resolved on denaturing polyacrylamide gels. A plot of fraction of substrate cleaved as a function of time is plotted. The fraction of RNA cleavage increased with an increase in the time of preincubation. The antibiotic-mediated enhancement in rates of cleavage is observed in solutions that already contains optimal concentrations of magnesium and KCl.

Referring to Figure 18, antibiotic-mediated lowering of the requirement of divalent cation (Mg<sup>2+</sup>) is discussed. RNA cleavage reaction catalyzed by the VS ribozyme is assayed under varying concentrations of magnesium chloride. VS RNA are pre-incubated with 75 mM viomycin for 30 min in the presence of 40 mM Tris-HCl. Reaction was initiated at 37°C by adding varying concentrations of MgCl<sub>2</sub>. A plot of rate (min<sup>-1</sup>) as a function of time is shown. The presence of viomycin appears to significantly lower the requirement of MgCl<sub>2</sub> in the reaction.

Sequences listed in Figures 6-9 are meant to be non-limiting. Those skilled in the art will recognize that variants (base-substitutions, deletions, insertions, mutations, chemical modifications) of the VS ribozyme can be readily generated using techniques known in the art, and are within the scope of the present invention.

#### Diagnostic uses

Ribozymes of this invention may be used as diagnostic tools to examine genetic drift and mutations within diseased cells, or to detect specific RNA molecules, such as virus RNA. The close relationship between ribozyme activity and the structure of the target RNA allows the detection of mutations in any region of the molecule which alters the base-pairing and three-dimensional structure of the target RNA. By using multiple ribozymes described in this invention, one may map nucleotide changes which are important to RNA structure and function *in vitro*, as well as in cells and tissues. Cleavage of target RNAs with ribozymes may be used to inhibit gene expression and define the role (essentially) of specified gene products in the progression of disease. In this manner, other genetic targets may be defined as important mediators of the disease. These experiments will lead to better treatment of the disease progression by affording the possibility of combinational therapies (e.g., multiple ribozymes targeted to different genes, ribozymes coupled with known small molecule inhibitors, or intermittent treatment with combinations of ribozymes and/or other chemical or biological molecules). Other *in vitro* uses of ribozymes of this invention are well known in the art, and include detection of the presence of mRNA associated with a related condition. Such RNA is detected by determining the presence of a cleavage product after treatment with a ribozyme using standard methodology.

In a specific example, ribozymes which can cleave only wild-type or mutant forms of the target RNA are used for

the assay. The first ribozyme is used to identify wild-type RNA present in the sample and the second ribozyme will be used to identify mutant RNA in the sample. As reaction controls, synthetic substrates of both wild-type and mutant RNA will be cleaved by both ribozymes to demonstrate the relative ribozyme efficiencies in the reactions and the absence of cleavage of the "non-targeted" RNA species. The cleavage products from the synthetic substrates will also serve to generate size markers for the analysis of wild-type and mutant RNAs in the sample population. Thus each analysis will require two ribozymes, two substrates and one unknown sample which will be combined into six reactions. The presence of cleavage products will be determined using an RNase protection assay so that full-length and cleavage fragments of each RNA can be analyzed in one lane of a polyacrylamide gel. It is not absolutely required to quantify the results to gain insight into the expression of mutant RNAs and putative risk of the desired phenotypic changes in target cells. The expression of mRNA whose protein product is implicated in the development of the phenotype is adequate to establish risk. If probes of comparable specific activity are used for both transcripts, then a qualitative comparison of RNA levels will be adequate and will decrease the cost of the initial diagnosis. Higher mutant form to wild-type ratios will be correlated with higher risk whether RNA levels are compared qualitatively or quantitatively.

TABLE ICharacteristics of Ribozymes**Group I Introns**

Size: ~200 to >1000 nucleotides.

Requires a U in the target sequence immediately 5' of the cleavage site.

Binds 4-6 nucleotides at 5' side of cleavage site.

Over 75 known members of this class. Found in *Tetrahymena thermophila* rRNA, fungal mitochondria, chloroplasts, phage T4, blue-green algae, and others.

**RNAseP RNA (M1 RNA)**

Size: ~290 to 400 nucleotides.

RNA portion of a ribonucleoprotein enzyme. Cleaves tRNA precursors to form mature tRNA.

Roughly 10 known members of this group all are bacterial in origin.

**Hammerhead Ribozyme**

Size: ~13 to 40 nucleotides.

Requires the target sequence UH immediately 5' of the cleavage site.

Binds a variable number nucleotides on both sides of the cleavage site.

14 known members of this class. Found in a number of plant pathogens (virusoids) that use RNA as the infectious agent (Figures 1 and 2)

**Hairpin Ribozyme**

Size: ~50 nucleotides.

Requires the target sequence GUC immediately 3' of the cleavage site.

Binds 4-6 nucleotides at 5' side of the cleavage site and a variable number to the 3' side of the cleavage site.

Only 3 known member of this class. Found in three plant pathogen (satellite RNAs of the tobacco ringspot virus, arabis mosaic virus and chicory yellow mottle virus) which uses RNA as the infectious agent (Figure 3).

**Hepatitis Delta Virus (HDV) Ribozyme**

Size: 50 - 60 nucleotides (at present).

Cleavage of target RNAs recently demonstrated.

Sequence requirements not fully determined.

Binding sites and structural requirements not fully determined, although no sequences 5' of cleavage site are required.

Only 1 known member of this class. Found in human HDV (Figure 4).

***Neurospora* VS RNA Ribozyme**

Size: ~144 nucleotides

Found in *Neurospora* VS RNA (Figure 5A).

Table II. Effect of base-substitutions on the rate of self-cleavage of the VS

## RNA

Helix	Base-Substitution	$k_{rel}^1$
--	G11 wild type	1.00 <sup>2</sup>
Ia	5' G624C/G625C	0.02
Ia	3' C634G/C635G	0.64
Ia	5'3'	<0.01
Ib	5' C626G	1.21
Ib	3' G633C	0.74
Ib	5'3'	0.31
Ic	5' G627C	0.64
Ic	3' C632G	<0.01
Ic	5'3'	<0.01
IIa	5' G650C	0.12
IIa	3' C773G	0.29
IIa	5'3'	1.27
IIb	5' G655C	<0.01
IIb	3' C769G	0.18
IIb	5'3'	1.32
IIc	5' G653C	<0.01
IIc	3' C771G	<0.01
IIc	5'3'	0.09
IIIa	5' U659A	<0.01
IIIa	3' A720U	0.05
IIIa	5'3'	1.19
IIIb	5' C662G	0.23
IIIb	3' G716C	0.21
IIIb	5'3'	0.94
IIIc	5' A661U/C662G	0.06
IIIc	3' G716C/U717A	0.02
IIIc	5'3'	0.08

IIIId	5' C665G	0.01
IIIId	3' G711C	F <sup>3</sup>
IIIId	5'3'	0.01
IV	5' U670A/C672G	0.54
IV	3' G678C/A681U	<0.01
IV	5'3'	0.88
Va	5' A690U/C692G	0.07
Va	3' G704C/U706A	0.78
Va	5'3'	1.48
Vb <sup>4</sup>	5' U695G	0.06
Vb <sup>4</sup>	3' A701C	0.04
Vb <sup>4</sup>	5'3'	1.67
Vc	5' A693U/G694C	ND <sup>5</sup>
Vc	3' C702G/U703A	ND <sup>5</sup>
Vc	5'3'	0.31
Vla	5' G722C/C723G	<0.01
Vla	3' G762C/C763G	<0.01
Vla	5'3'	0.75
Vlb	5' G727C/U728A	<0.01
Vlb	3' A759U/C760G	<0.01
Vlb	5'3'	0.94
Vlc	5' A735U/U737A	0.25
Vlc	3' A748U/U750A	0.28
Vlc	5'3'	1.15
652ΔA		<0.01
A652G		<0.01
718ΔA		0.15

<sup>1</sup> rate constant of the mutant divided by the rate constant of wild-type G11.

<sup>2</sup> the rate constant for the G11 varied from <sup>2</sup> 0.06 to 0.08 min<sup>-1</sup>.

<sup>3</sup> cleavage rate not measured accurately, but similar to wild type.

<sup>4</sup> these mutants were made in a variant of G11 that contained two different base pairs in helix V (mutant Vc). Rates are normalized using mutant Vc as the relevant wild type.

<sup>5</sup> cleavage rate not determined.

Claims

1. Ribozyme able to cleave a separate substrate RNA molecule, said ribozyme having three base-paired regions generally in an "I" configuration, wherein the upper and lower base-paired regions comprising between 4 and 80 bases inclusive of which at least 50% are paired with each other, and wherein a connecting region between said upper and lower base paired regions comprises between 4 and 20 bases inclusive of which at least about 50% are paired with each other.
2. The ribozyme of claim 1, wherein said connecting region further comprises a single-stranded region of between 1 and 7 bases inclusive.
3. The ribozyme of claim 2, wherein said single-stranded region is adjacent said upper base-paired region.
4. The ribozyme of claim 1, wherein said upper region comprises a left and right hand portion each between at least 3 and 30 bases inclusive.
5. The ribozyme of claim 1, wherein said lower region comprises a left and right hand portion each between at least 3 and 30 bases inclusive.
6. The ribozyme of claim 1, wherein said lower region comprises at least one bulged base.
7. The ribozyme of claim 1, wherein said connecting region comprises at least one bulged base.
8. The ribozyme of claim 1, wherein said upper base paired region comprises bases unpaired with other

bases in said upper base-paired region which are available to base pair with a substrate RNA.

9. The ribozyme of claim 8, wherein said bases which are unpaired comprise at least 3 bases.
- 5 10. The ribozyme of claim 1, wherein the substrate for said ribozyme comprises a base paired region comprising at least 2 base pairs.
- 10 11. The ribozyme of claim 10, wherein said substrate comprises the sequence 3'GANN 5' wherein cleavage by said ribozyme is between each said N, and wherein each N independently is any base.
12. The ribozyme of claim 1, wherein said lower base-paired region comprises unpaired bases at its 5' end, available to base pair with a substrate RNA.
- 15 13. The ribozyme of claim 1, wherein said ribozyme contacts said RNA substrate only 3' of the cleavage site,
14. The ribozyme of claim 1, wherein said RNA substrate is a double-stranded RNA, wherein said nucleic acid molecule is able to contact said double-stranded RNA substrate only 3' of the cleavage site and cause cleavage of said RNA substrate at the cleavage site.
- 20 15. The ribozyme of claim 1, wherein said RNA substrate is a single-stranded RNA, and wherein said ribozyme is able to contact said single-stranded RNA substrate only 3' of the cleavage site and cause cleavage of said RNA substrate at the cleavage site.
- 25 16. The ribozyme of claim 1, wherein said nucleic acid molecule is derived from *Neurospora* VS RNA.
- 30 17. The ribozyme of claim 1, wherein said ribozyme is enzymatically active to cut an RNA duplex having at least two base-pairs.

- 5 18. The ribozyme of claim 1, wherein said ribozyme is enzymatically active to cut 5' to the sequence,  $NAGN_nGUCN_m$ , wherein each N is independently any nucleotide base, wherein n and m are independently an integer between 3 and 20 inclusive, and wherein said sequence forms at least internal two base-pairs.
- 10 19. The ribozyme of claim 1, wherein, said RNA substrate binds said ribozyme at a site distant from said cleavage site.
- 15 20. The ribozymes of claim 1, wherein said ribozyme is a circular molecule, wherein said circular molecule contacts a separate RNA substrate and causes cleavage of said RNA substrate at a cleavage site.
- 20 21. The ribozyme of claim 1, wherein said ribozyme comprises ribonucleotides.
- 25 22. A cell comprising nucleic acid encoding the ribozyme of claim 1.
23. An expression vector comprising nucleic acid encoding the ribozyme of claim 1, in a manner which allows expression of said ribozyme within a cell.
24. A cell including an expression vector of claim 23.
- 25 25. An expression vector of claim 23, wherein the ribozyme encoded by said vector is capable of cleaving a separate RNA substrate molecule selected from a group consisting of viral RNA, messenger RNA, pathogenic RNA and cellular RNA.
- 30 26. The ribozyme of claim 1, wherein the activity of the said ribozyme is increased by a cofactor.
27. The ribozyme of claim 26 wherein said cofactor is selected from the group consisting of antibiotics and peptides.

28. Method for cleaving a separate RNA molecule comprising, contacting said molecule with a ribozyme of claim 1.

1/22

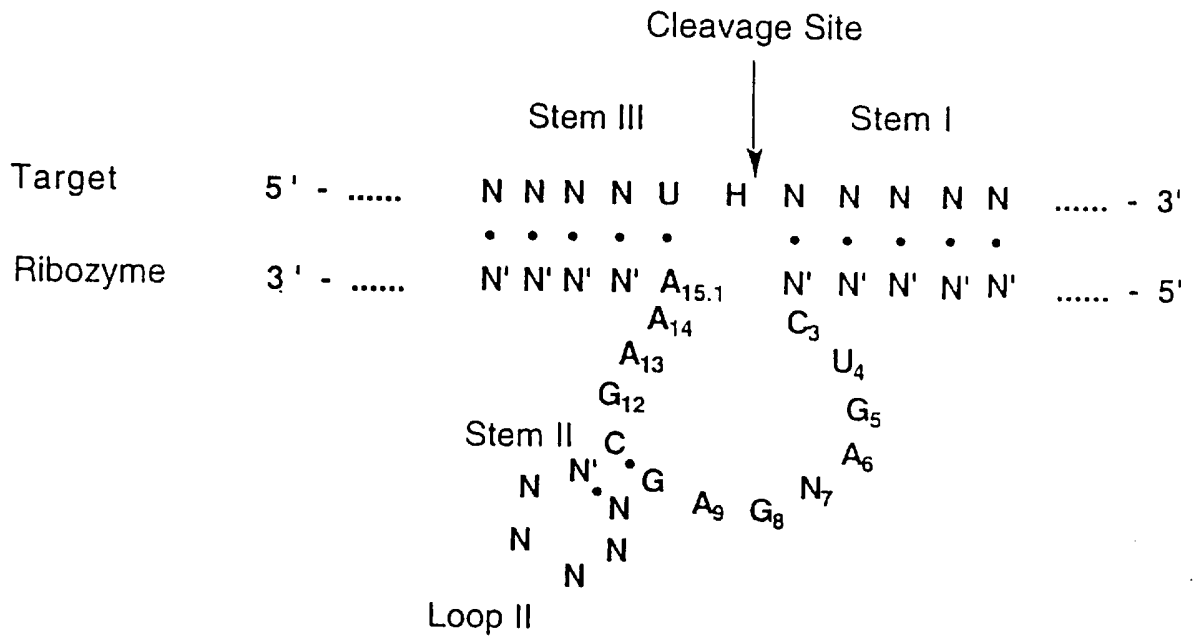

FIG. 1

FIG.2B

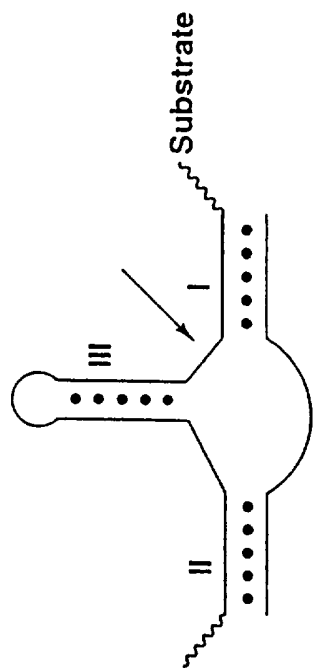

FIG.2D

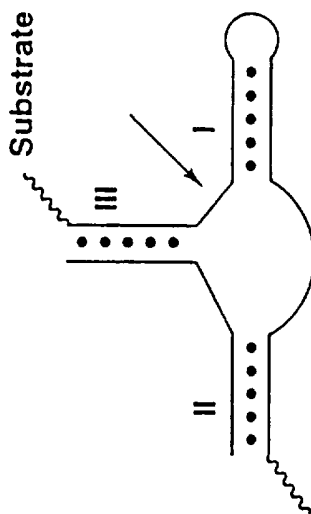

FIG.2A

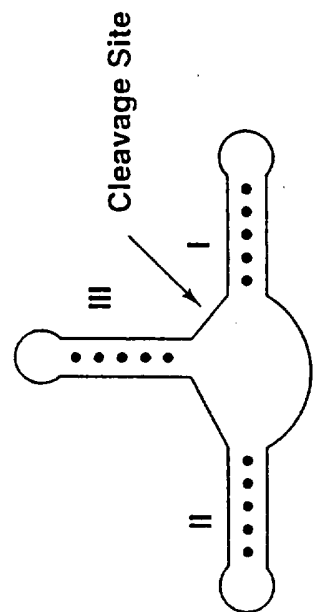
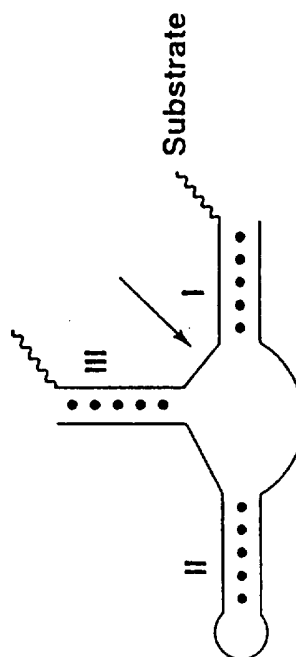

FIG.2C



3/22

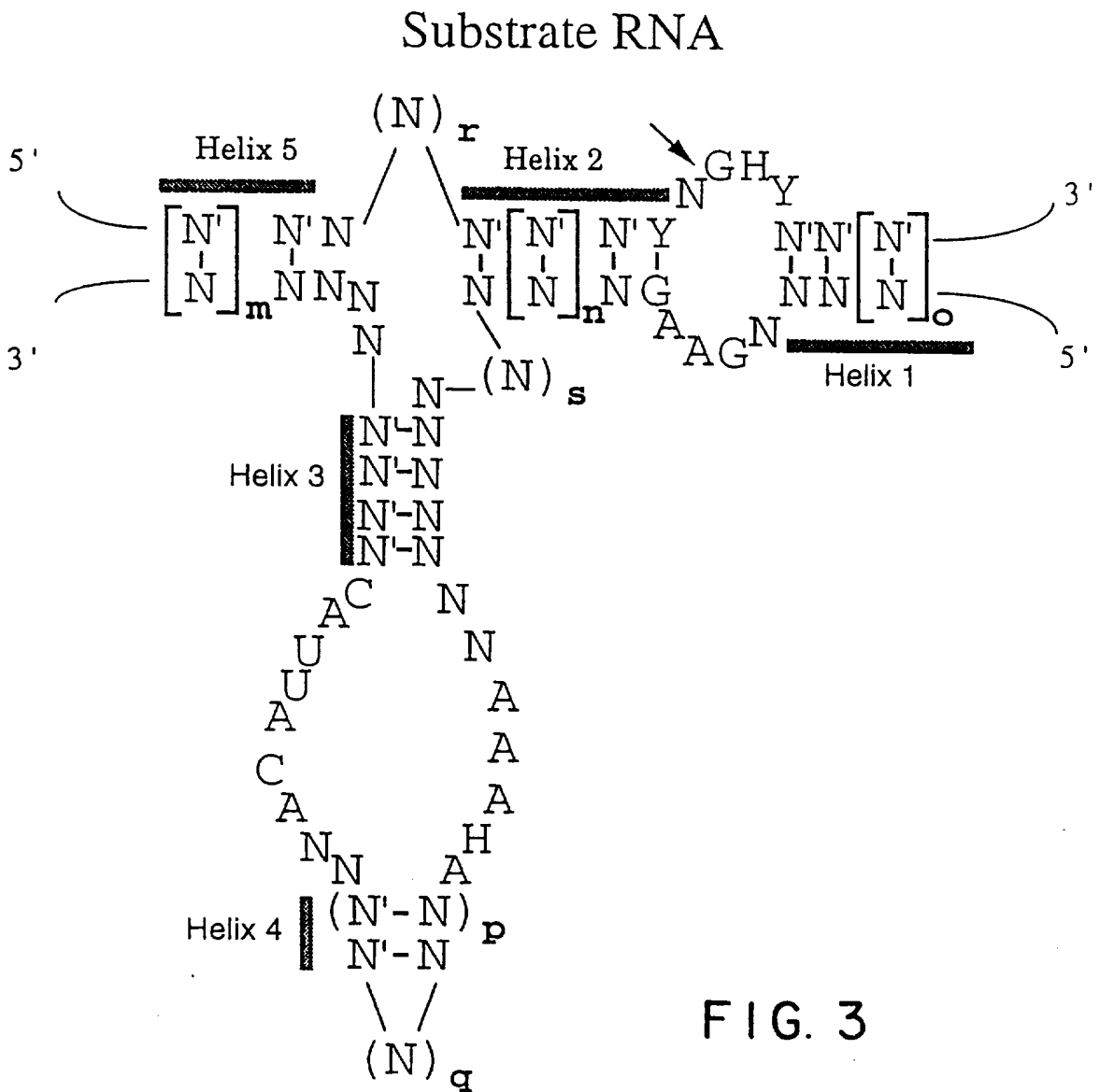

FIG. 3

4/22

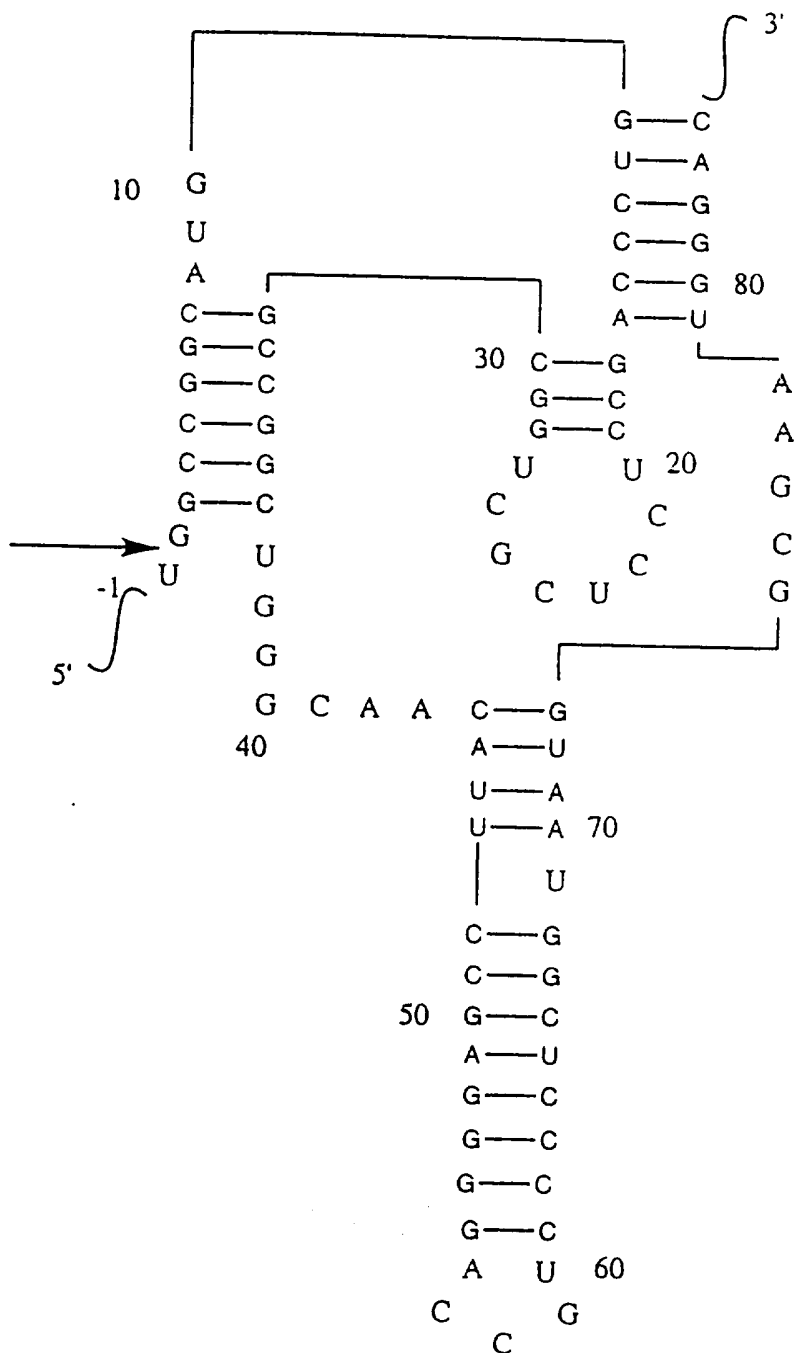
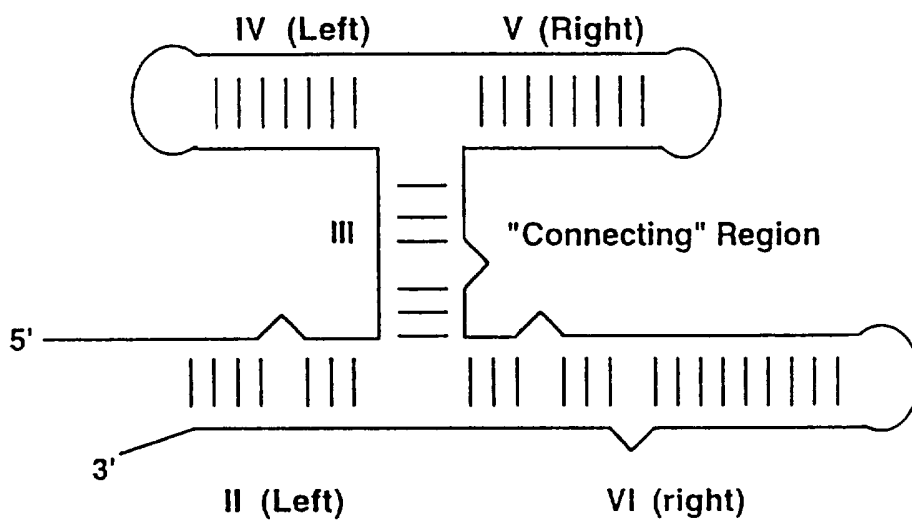

FIG. 4



6/22

"Upper" Base-Paired Region



"Lower" Base-Paired Region

FIG. 5B

7/22

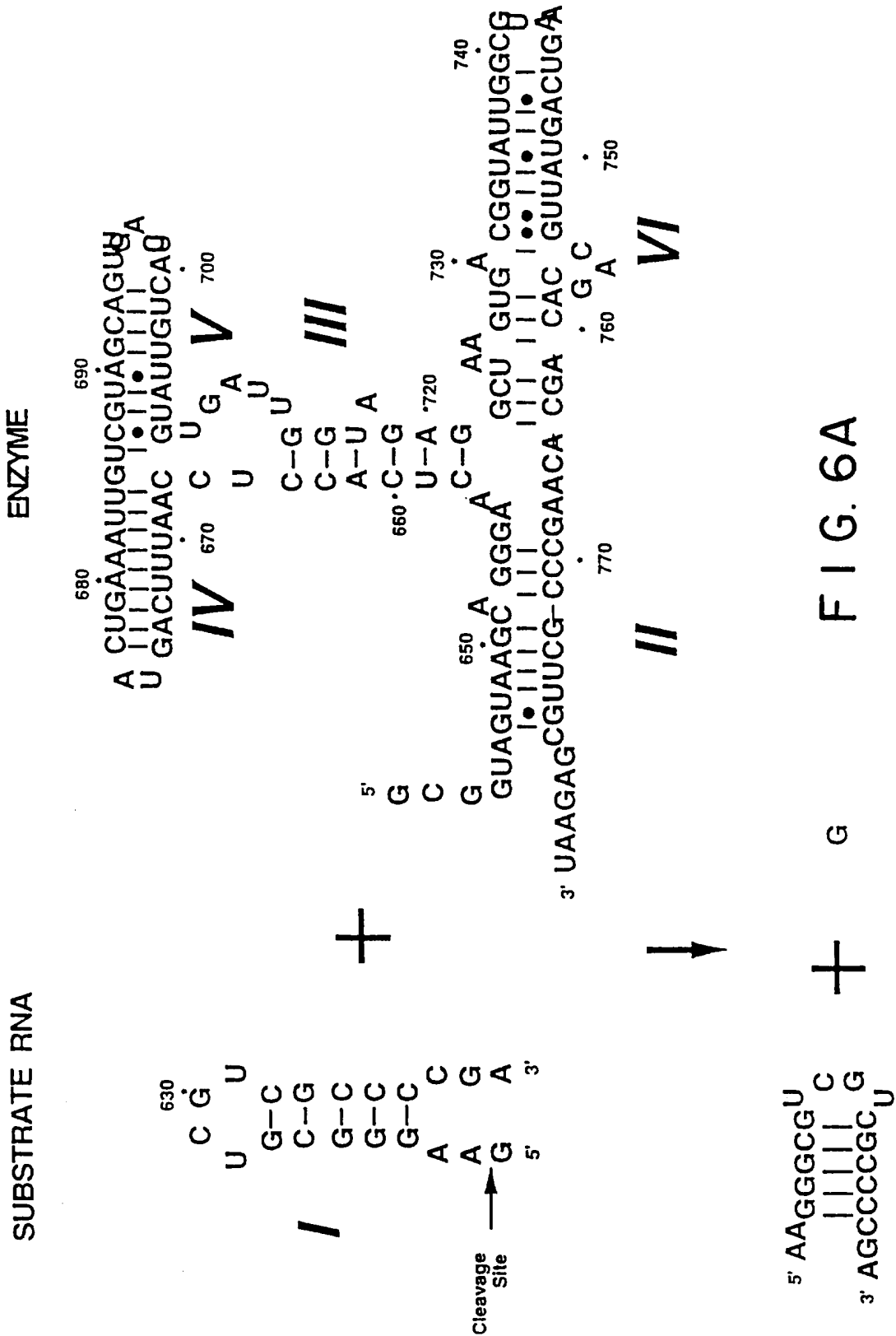







10/22

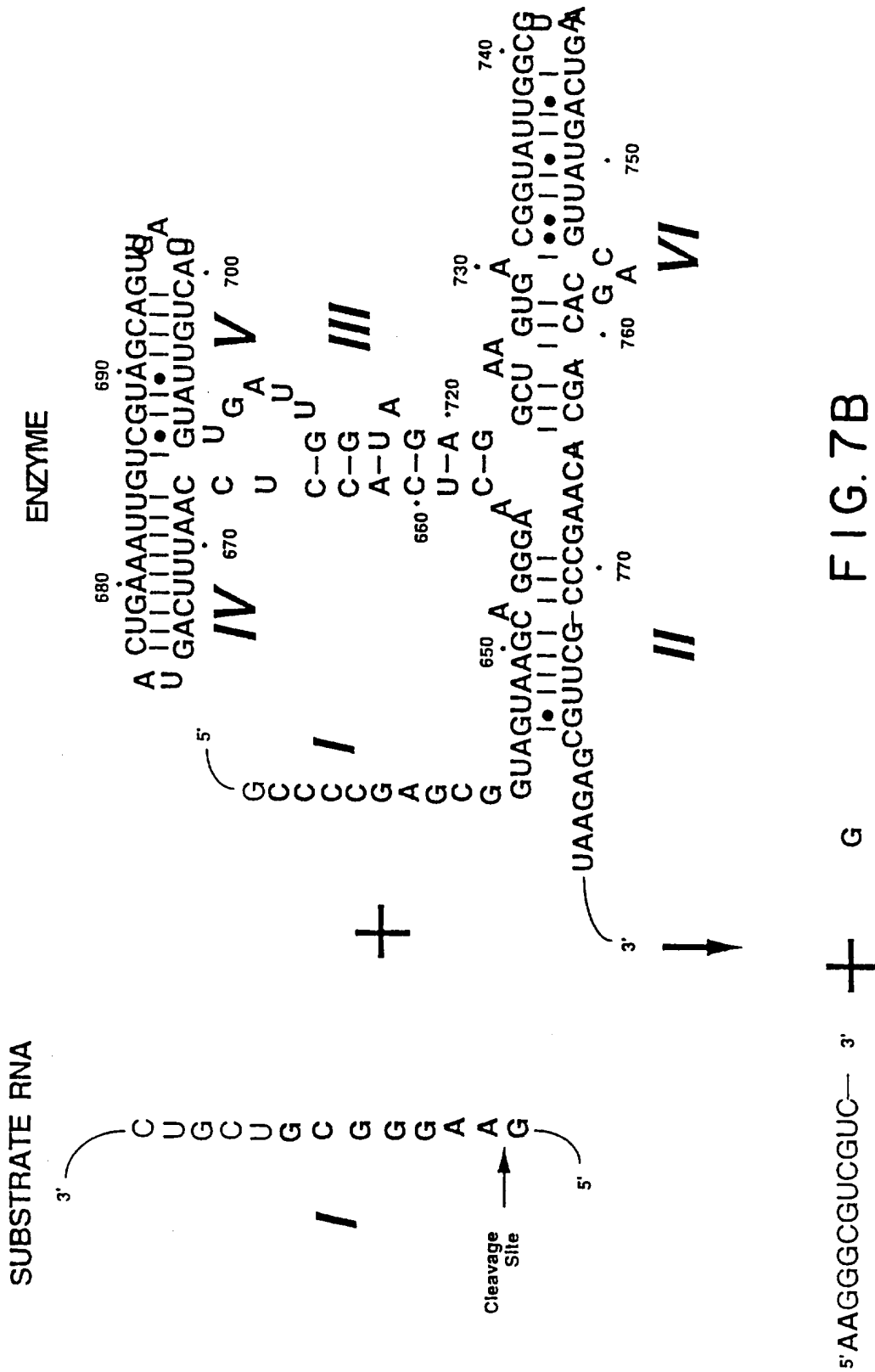

FIG. 7B

11/22

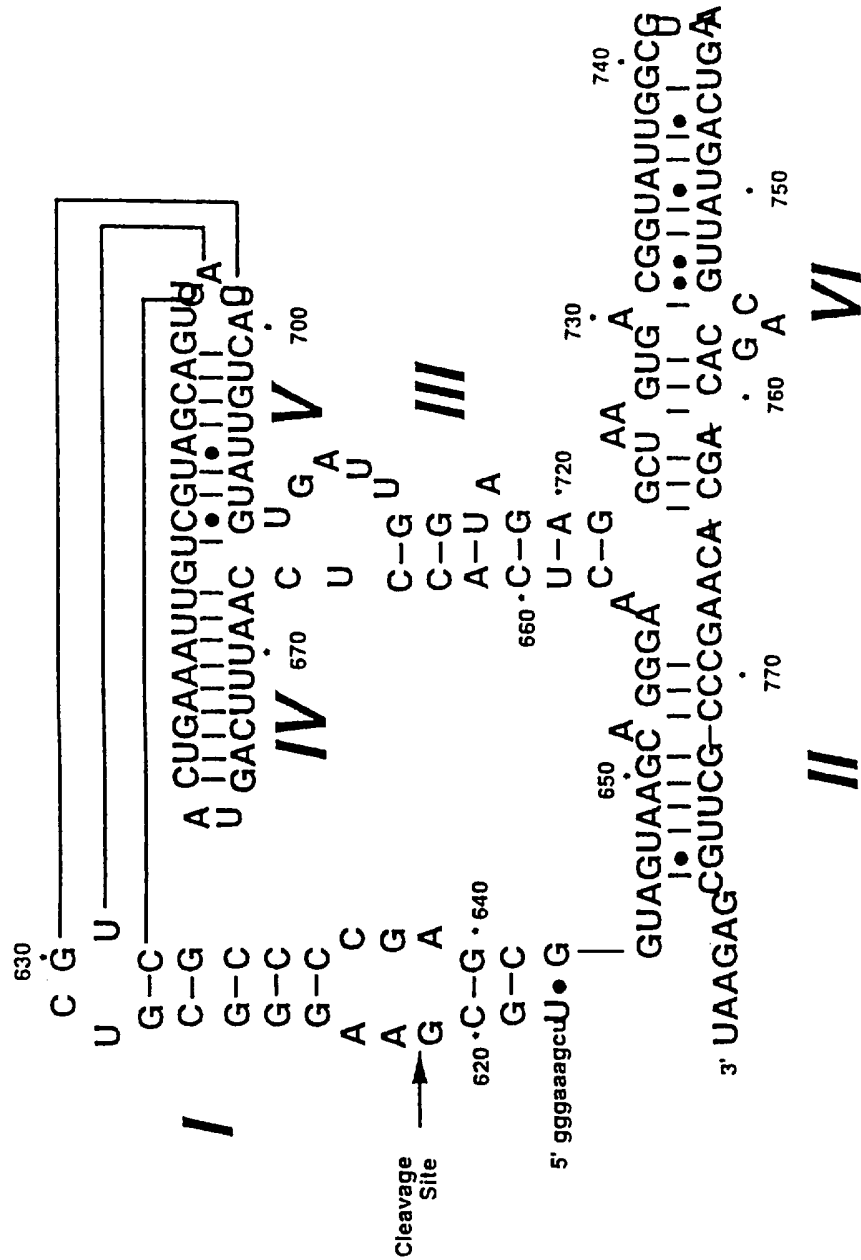
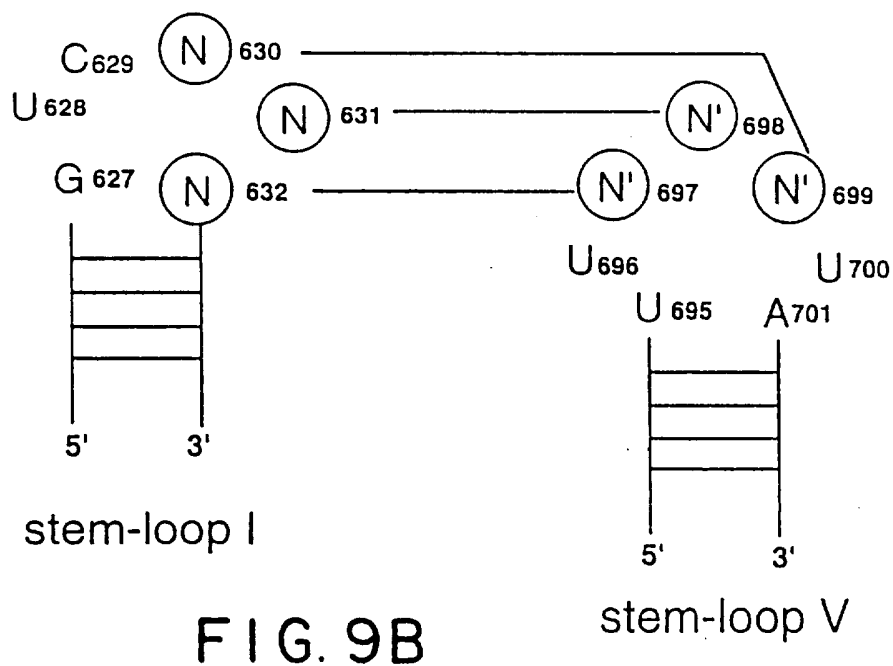
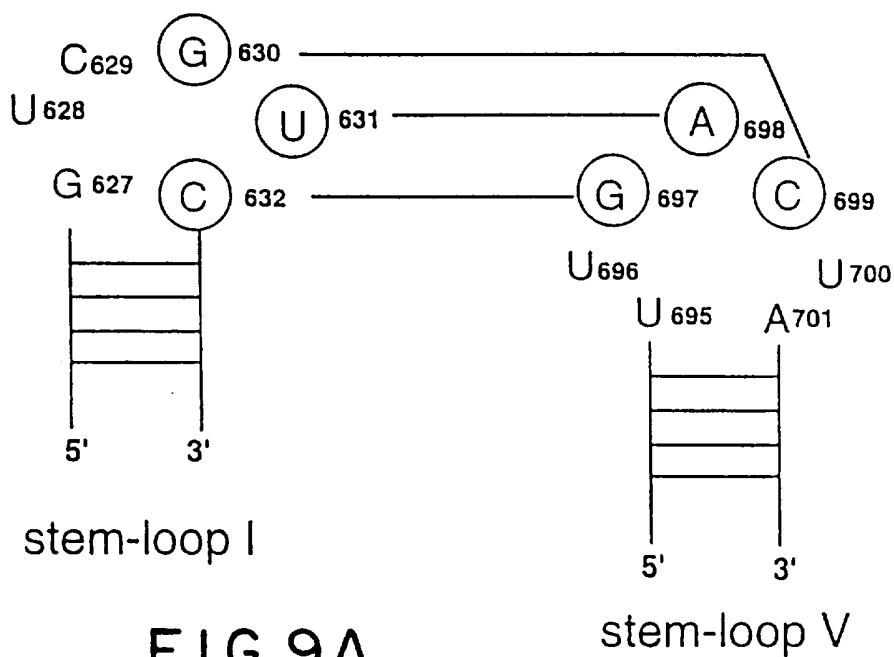

FIG. 8

12/22



13/22

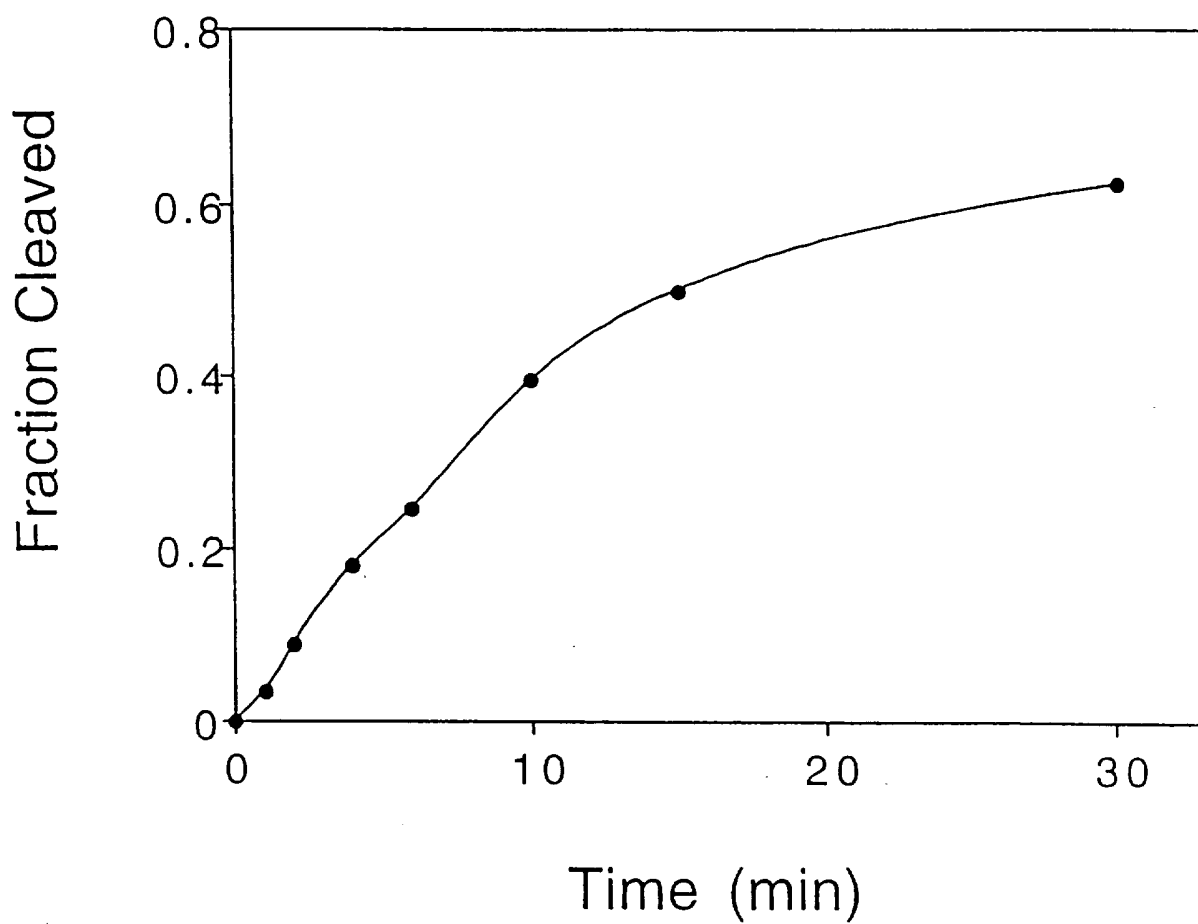

FIG. 10

14/22

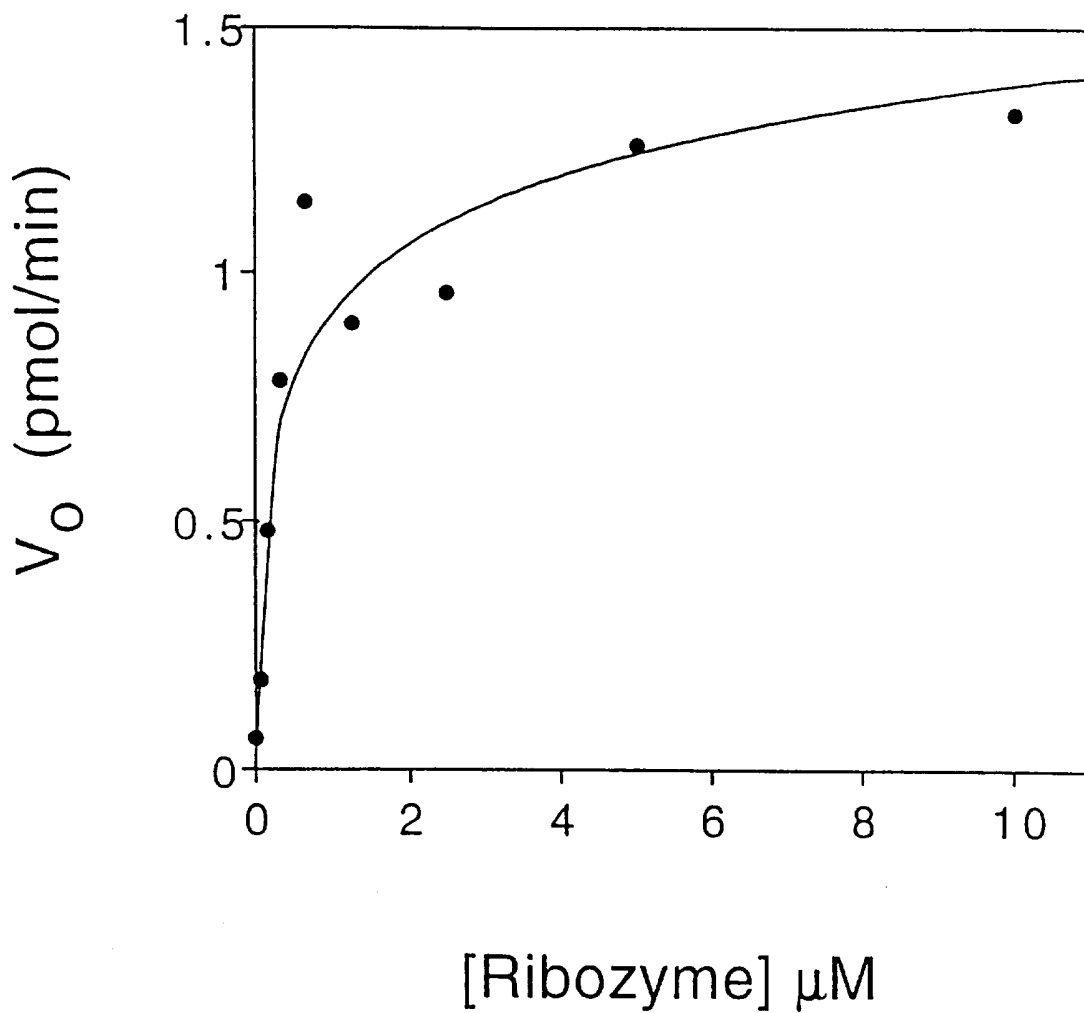

FIG. II

15/22

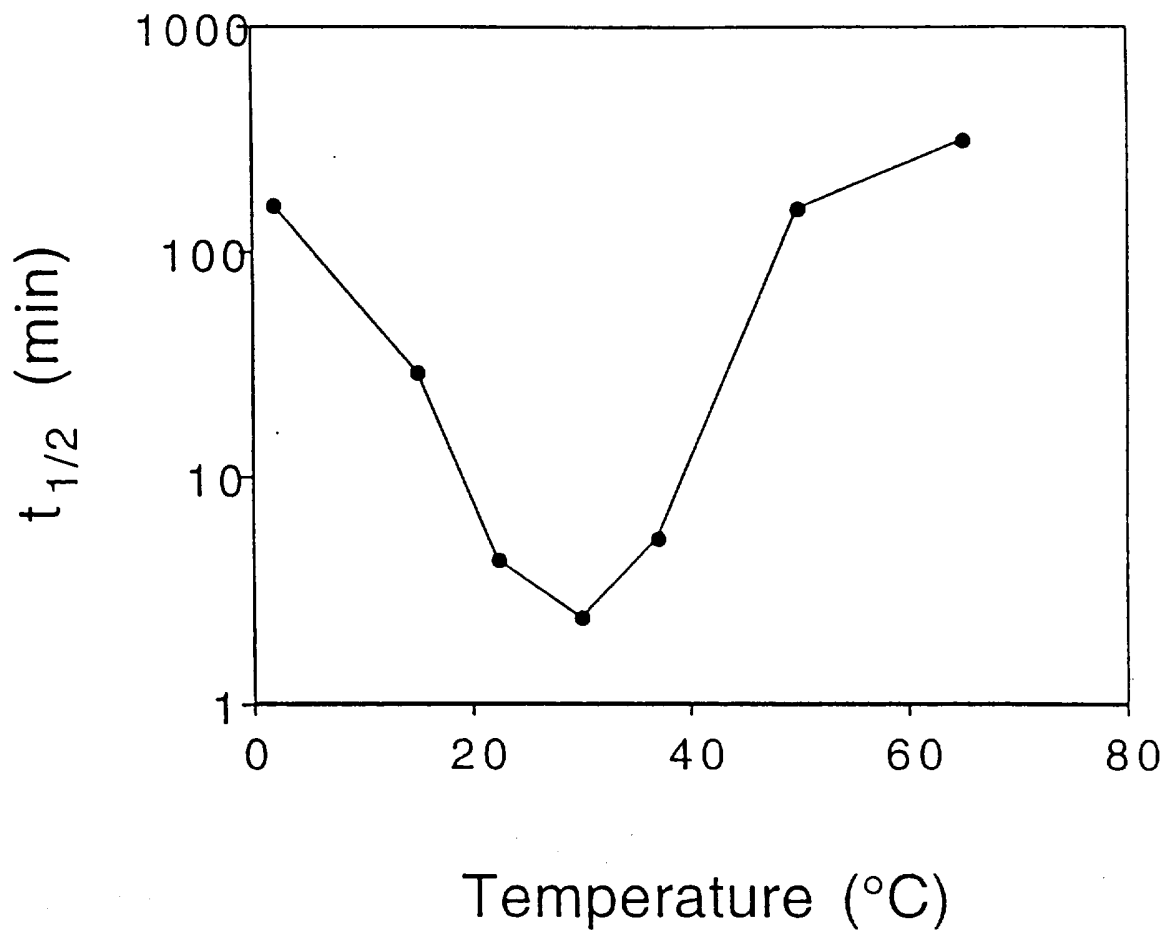

FIG. 12

16/22

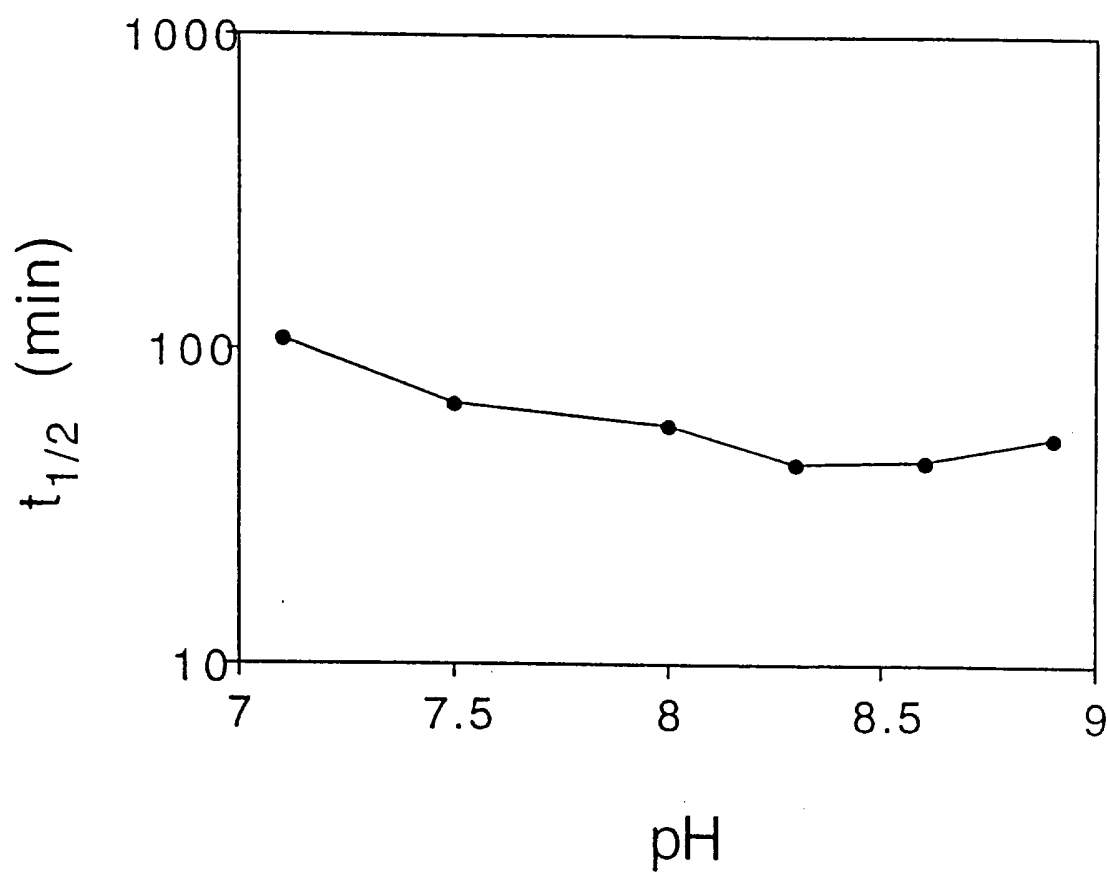

FIG. 13

17/22

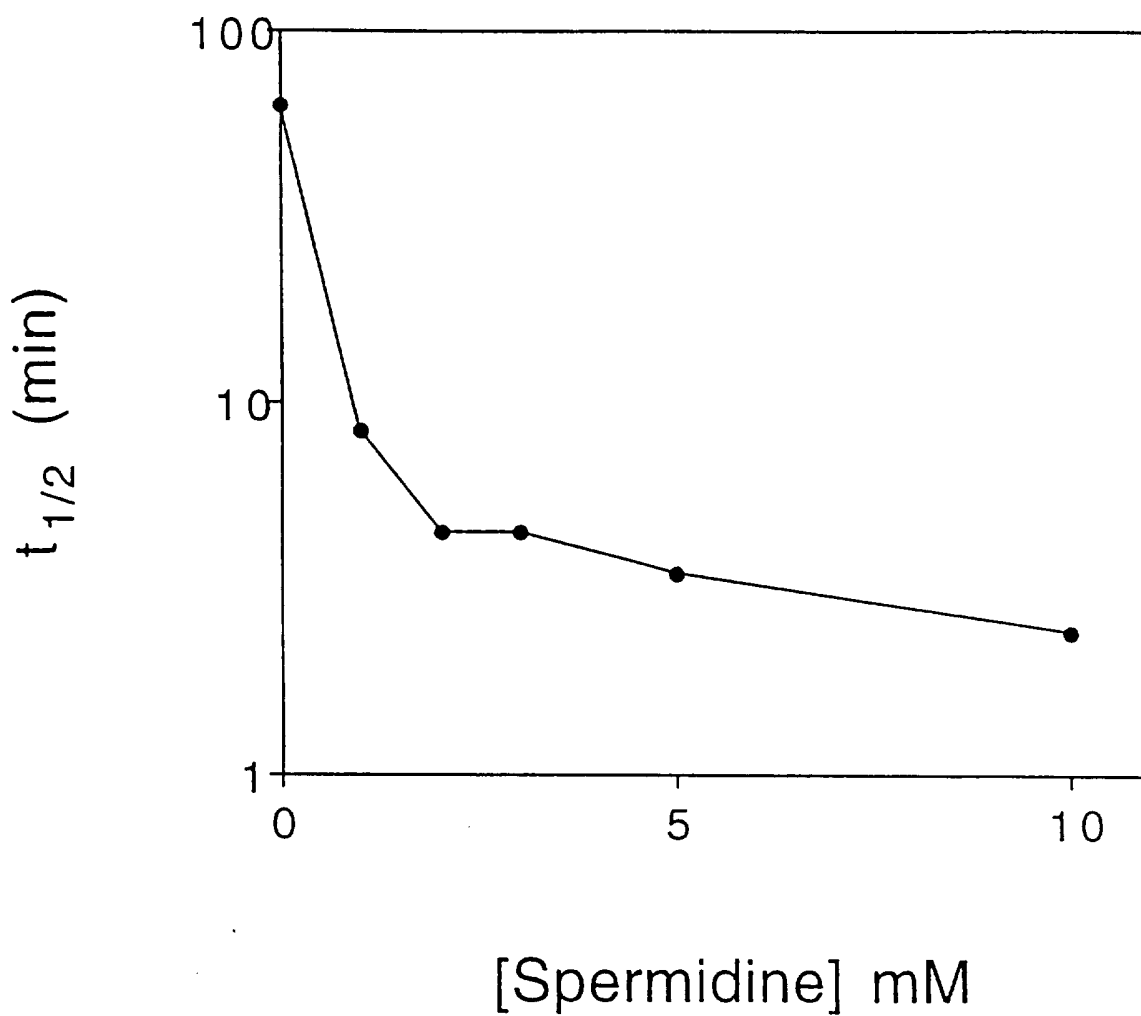

FIG. 14

18/22

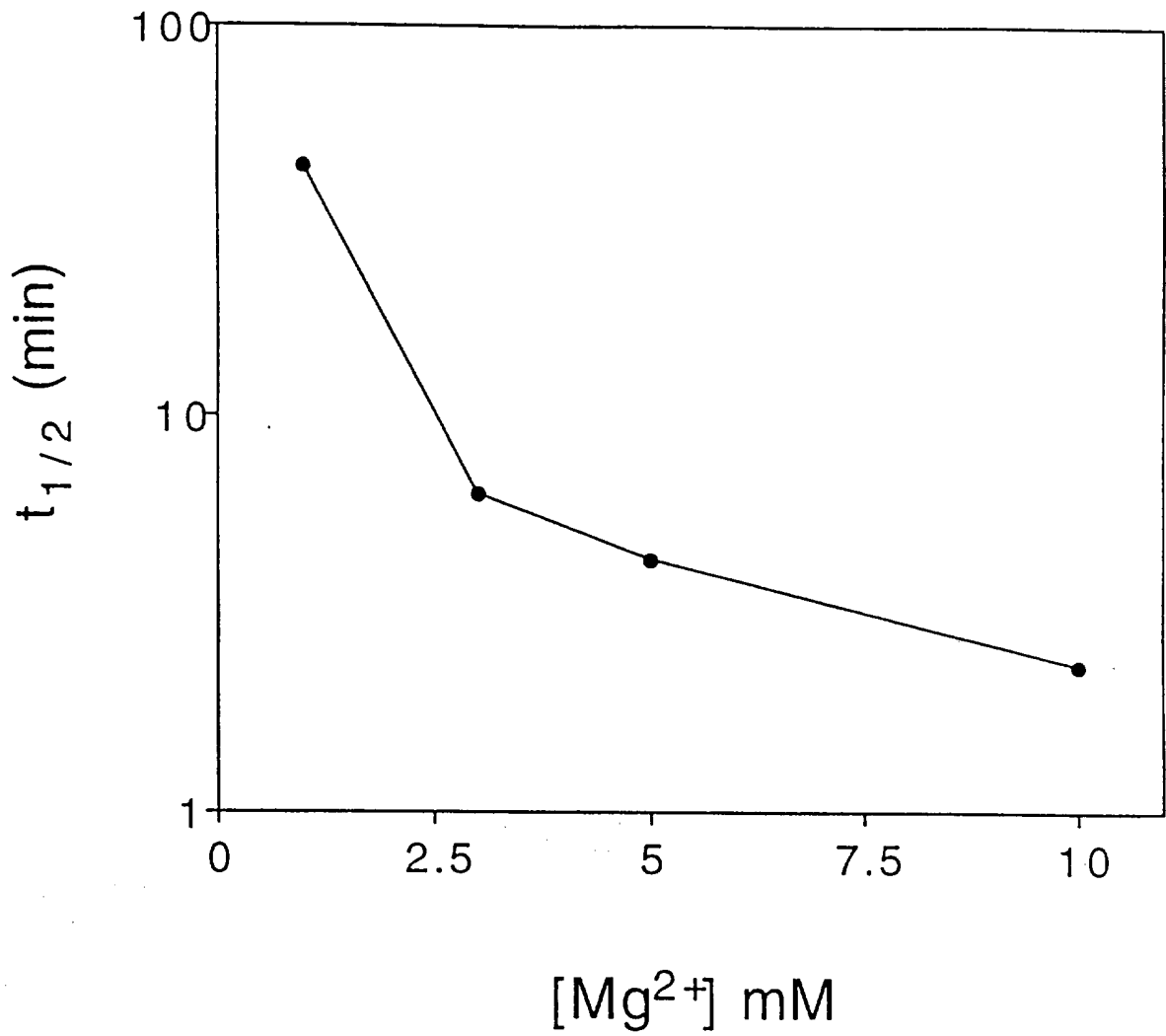

FIG.15

19/22

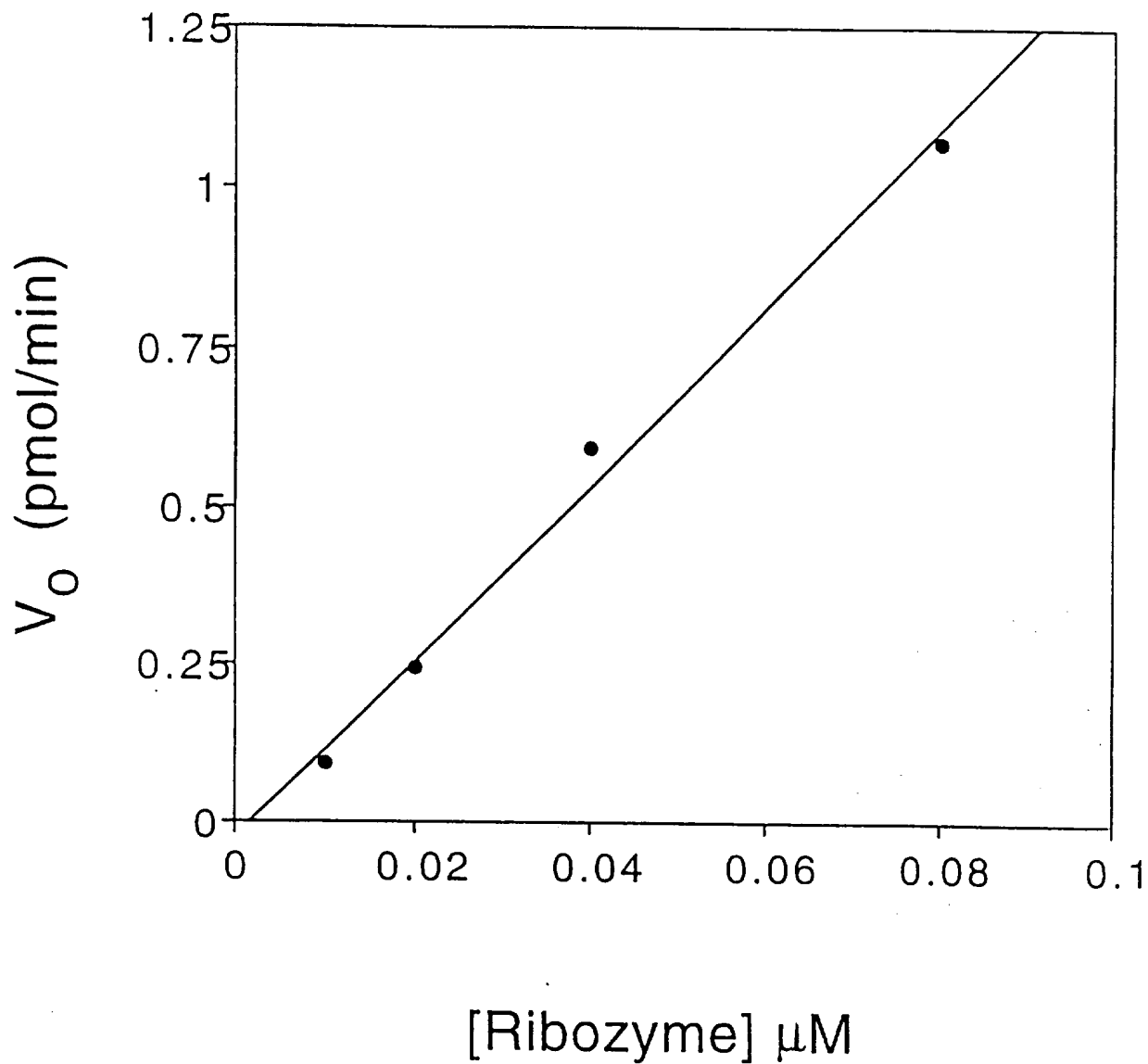

FIG.16A

20/22

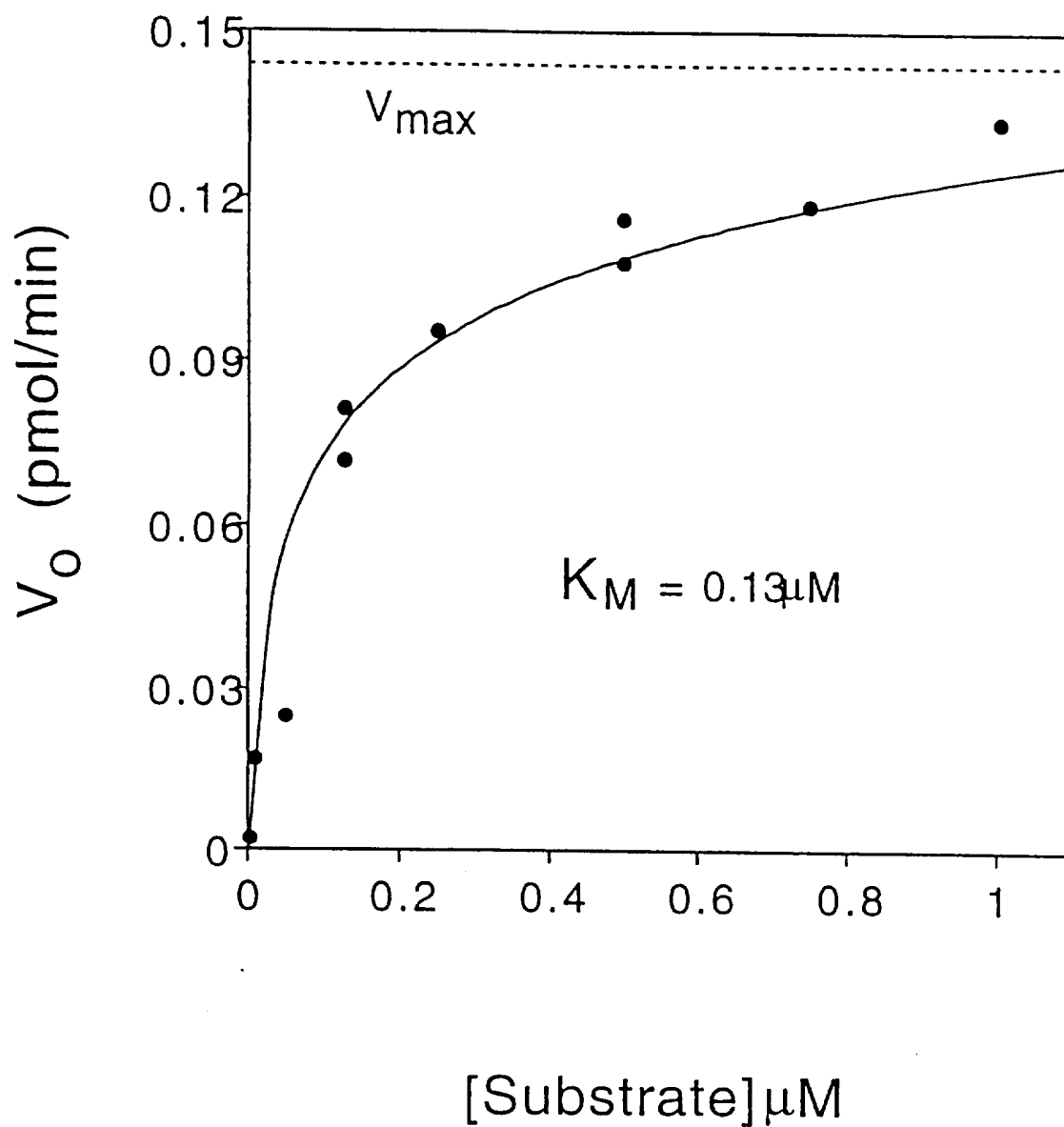

FIG. 16B

21/22

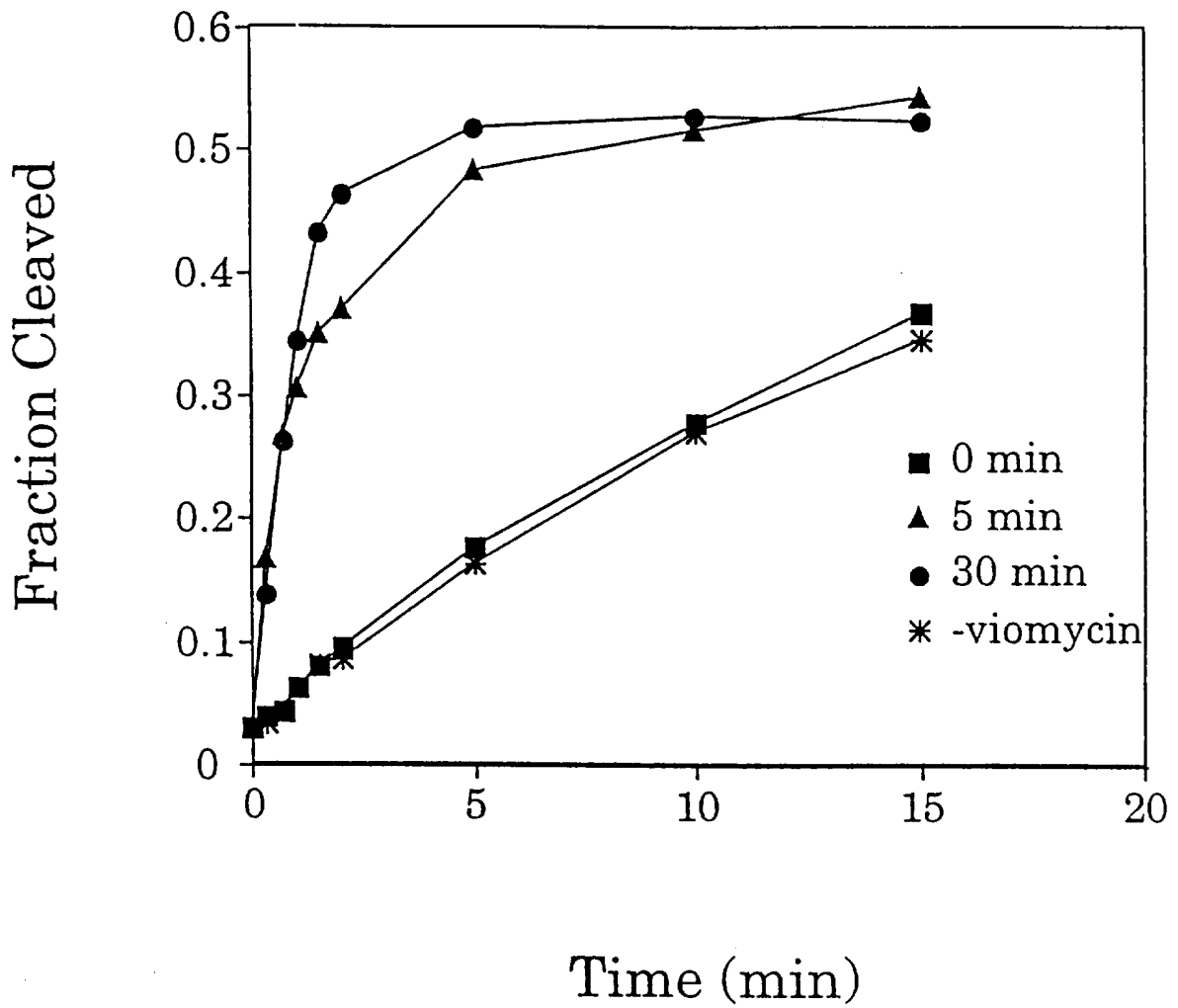

FIG.17

22/22

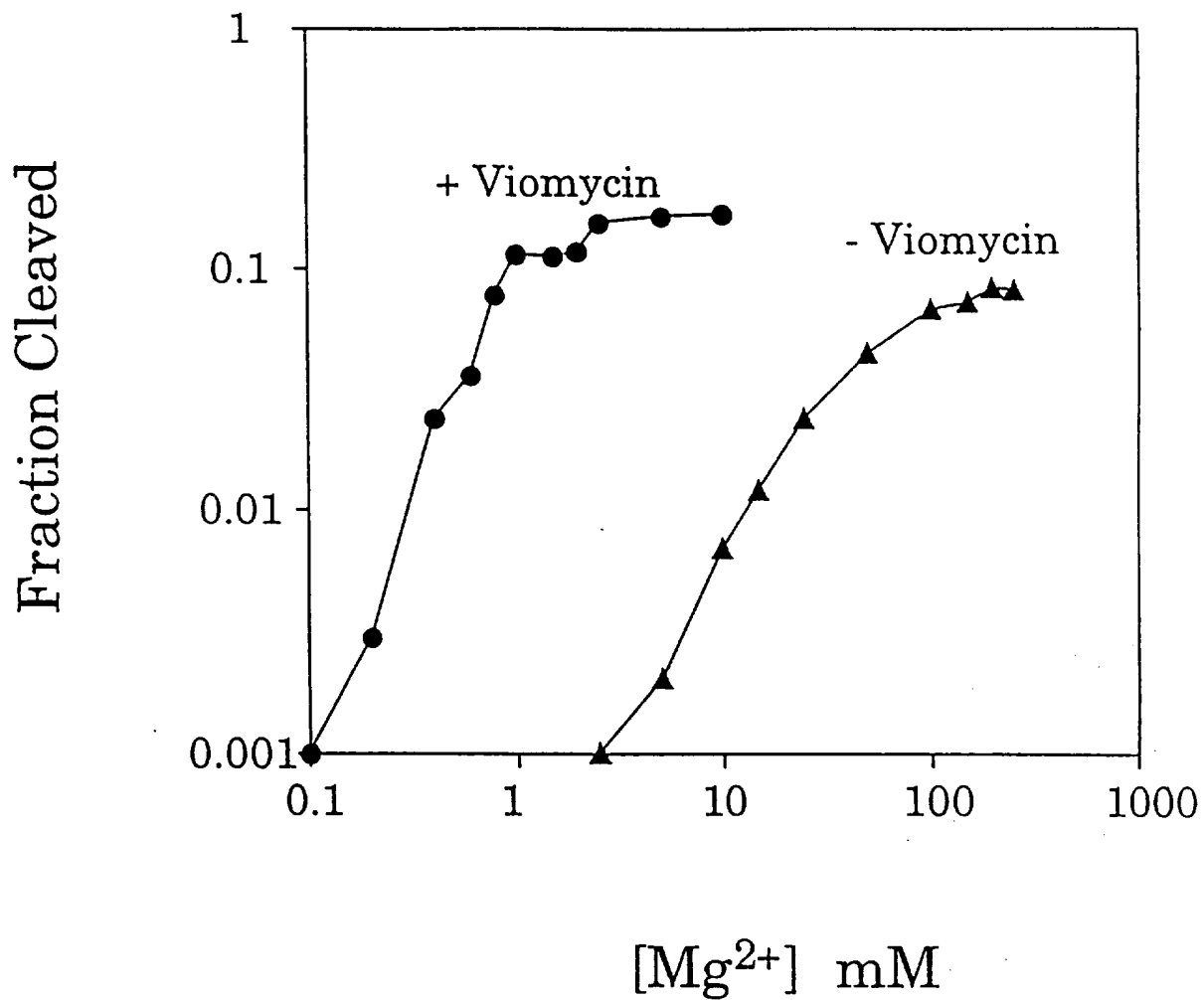

FIG. 18

**INTERNATIONAL SEARCH REPORT**

Intern al Application No  
PCT/IB 95/00141

**A. CLASSIFICATION OF SUBJECT MATTER**  
IPC 6 C12N15/52 C12N9/00 C12Q1/68

According to International Patent Classification (IPC) or to both national classification and IPC

**B. FIELDS SEARCHED**

Minimum documentation searched (classification system followed by classification symbols)  
IPC 6 C12N

Documentation searched other than minimum documentation to the extent that such documents are included in the fields searched

Electronic data base consulted during the international search (name of data base and, where practical, search terms used)

**C. DOCUMENTS CONSIDERED TO BE RELEVANT**

Category *	Citation of document, with indication, where appropriate, of the relevant passages	Relevant to claim No.
X	J MOL BIOL 232 (2). 1993. 351-361, GUO, H. ET AL. 'NUCLEOTIDE SEQUENCE REQUIREMENTS FOR SELF-CLEAVAGE OF NEUROSPORA VS RNA.' cited in the application see the whole document ---	1-13, 16, 18, 21-24, 28
X	BIOCHEMISTRY, vol. 32, 23 March 1993 EASTON, PA US, pages 2795-2799, COLLINS, R. & OLIVE, J. 'Reaction conditions and kinetics of self-cleavage of a ribozyme derived from Neurospora VS RNA' cited in the application see page 2797, right column, paragraph 2; figure 4 ---	1, 16, 22-24, 26
	-/--	

Further documents are listed in the continuation of box C.

Patent family members are listed in annex.

\* Special categories of cited documents :

- |   |   |
|---|---|
| <ul style="list-style-type: none"> <li>"A" document defining the general state of the art which is not considered to be of particular relevance</li> <li>"E" earlier document but published on or after the international filing date</li> <li>"L" document which may throw doubts on priority claim(s) or which is cited to establish the publication date of another citation or other special reason (as specified)</li> <li>"O" document referring to an oral disclosure, use, exhibition or other means</li> <li>"P" document published prior to the international filing date but later than the priority date claimed</li> </ul> | <ul style="list-style-type: none"> <li>"T" later document published after the international filing date or priority date and not in conflict with the application but cited to understand the principle or theory underlying the invention</li> <li>"X" document of particular relevance; the claimed invention cannot be considered novel or cannot be considered to involve an inventive step when the document is taken alone</li> <li>"Y" document of particular relevance; the claimed invention cannot be considered to involve an inventive step when the document is combined with one or more other such documents, such combination being obvious to a person skilled in the art.</li> <li>"&amp;" document member of the same patent family</li> </ul> |
|---|---|

Date of the actual completion of the international search

31 August 1995

Date of mailing of the international search report

19. 09. 95

Name and mailing address of the ISA

European Patent Office, P.B. 5818 Patentlaan 2  
NL - 2280 HV Rijswijk  
Tel. (+ 31-70) 340-2040, Tx. 31 651 epo nl,  
Fax (+ 31-70) 340-3016

Authorized officer

Andres, S

## INTERNATIONAL SEARCH REPORT

Intern. Application No  
PCT/IB 95/00141

C.(Continuation) DOCUMENTS CONSIDERED TO BE RELEVANT		
Category *	Citation of document, with indication, where appropriate, of the relevant passages	Relevant to claim No.
A	<p>CELL, vol. 61, 18 May 1990 NA US, pages 685-696, SAVILLE, B. &amp; COLLINS, R. 'A site-specific self-cleavage reaction performed by a novel RNA in Neurospora mitochondria' cited in the application see the whole document ----</p>	1-25, 28
T	<p>EMBO JOURNAL, vol. 14, no. 13, 3 July 1995 EYNHAM, OXFORD GB, pages 3247-3251, OLIVE, J. ET AL. 'Enhancement of Neurospora VS ribozyme cleavage by tuberactinomycin antibiotics' see the whole document ----</p>	1-28
T	<p>PROCEEDINGS OF THE NATIONAL ACADEMY OF SCIENCES OF THE UNITED STATES OF AMERICA 92 (10). 4686-4690, 9 May 1995 BEATTIE, T. ET AL. 'A secondary-structure model for the self-cleaving region of Neurospora VS RNA.' see the whole document -----</p>	1-28