

A. HAUTY,
RAILROAD SIGNAL.
APPLICATION FILED FEB. 28, 1907.

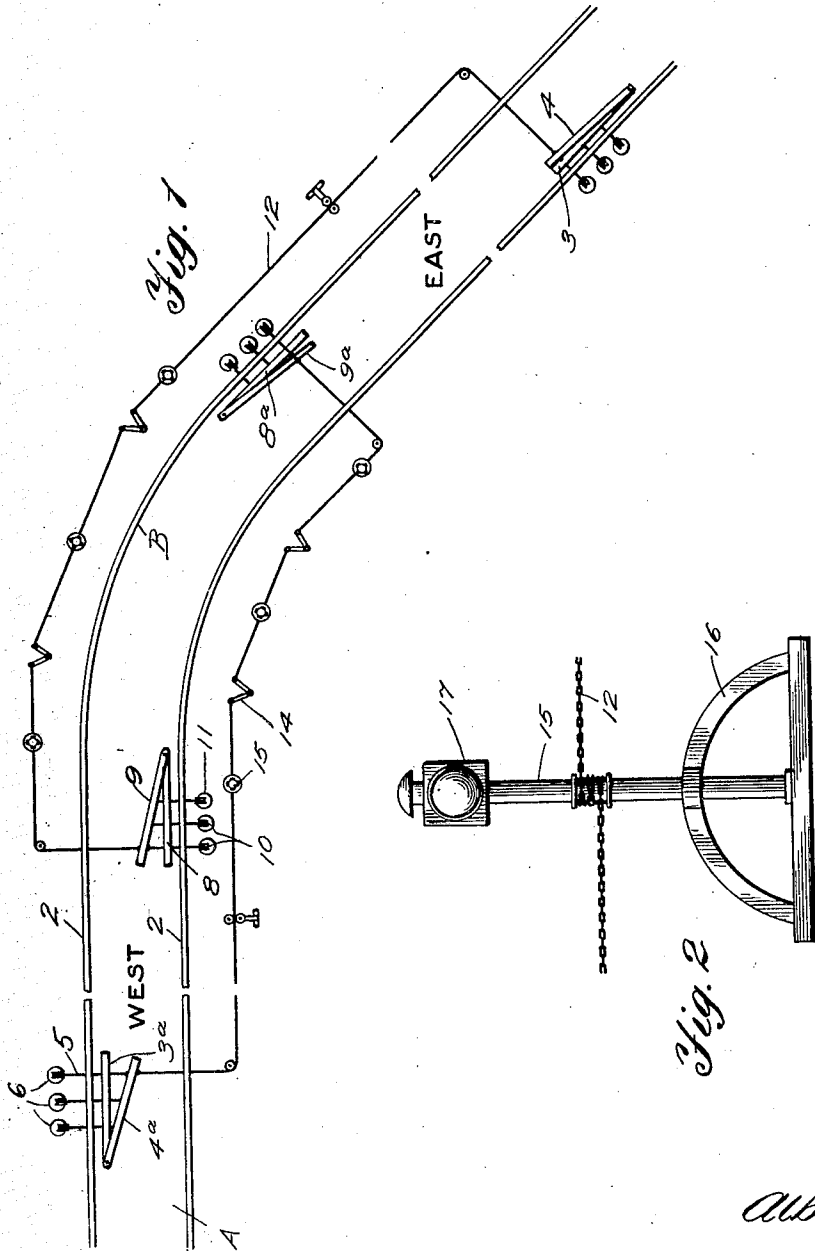

Witnesses
Reelafin
Wm Bagger

Inventor
Albert Hauty
 By *Victor J. Evans*
 Attorney

No. 860,468.

PATENTED JULY 16, 1907.

A. HAUTY.
RAILROAD SIGNAL.
APPLICATION FILED FEB. 28, 1907.

2 SHEETS—SHEET 2.

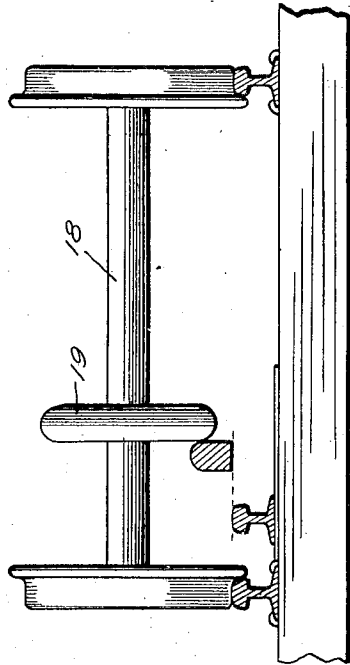

Fig. 4

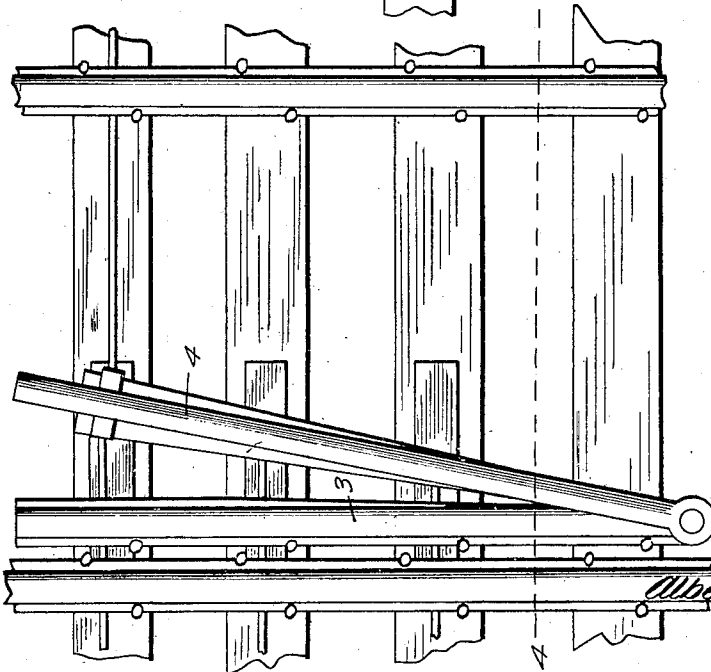

Fig. 3.

Inventor
Albert Hauty

Witnesses

Reedlin
Wm. Bagger

By *Victor J. Evans*
Attorney

UNITED STATES PATENT OFFICE.

ALBERT HAUTY, OF CHICAGO, ILLINOIS.

RAILROAD-SIGNAL.

No. 860,468.

Specification of Letters Patent.

Patented July 16, 1907.

Application filed February 28, 1907. Serial No. 359,753.

To all whom it may concern:

Be it known that I, ALBERT HAUTY, a citizen of the United States, residing at Chicago, in the county of Cook and State of Illinois, have invented new and useful Improvements in Railroad-Signals, of which the following is a specification.

This invention relates to railroad signals and to means for operating the same, and it has for its object to provide a signal which shall be automatically set by a train passing around a curve to indicate danger to a train approaching from the opposite direction upon the same line of rails, so as to avoid disastrous collisions which frequently occur when trains approach each other from opposite directions upon the same line of rails when there is an intervening curve which prevents the engineer of each train from observing the other one approach.

With these and other ends in view which will readily appear as the nature of the invention is better understood, the same consists in the improved construction and novel arrangement and combination of parts which will be hereinafter fully described and particularly pointed out in the claims.

In the accompanying drawing has been illustrated a simple and preferred form of the invention; it being, however, understood that no limitation is necessarily made to the precise structural details therein exhibited, but that changes, alterations and modifications within the scope of the invention may be resorted to when desired.

In the drawings, Figure 1 is a diagram illustrating a railroad curve adjacent to which signals constructed in accordance with this invention have been placed. Fig. 2 is a side view showing in elevation one of the posts carrying the signal lights. Fig. 3 is a detail top plan view of a portion of the track showing the means for actuating the signal. Fig. 4 is a transverse sectional view of a portion of the track taken on the plane indicated by the line 4-4 in Fig. 3, and showing also a portion of a truck having means for engaging the signal actuating mechanism.

Corresponding parts in the several figures are denoted by like characters of reference.

A designates a railroad track the rails of which 2-2 form a distinct curve, at B, the radius of said curve being so short that observation of the track for a considerable distance ahead will be impossible to the engineer of a train approaching the curve from either end. For convenience of description the ends of the curve will be designated respectively "east" and "west."

At a suitable distance from each end of the curve, adjacent to the opposite line rails, are placed guard rails 3-3^a, and upon said guard rails, at the ends thereof which are distant from the curve, are pivoted levers 4-4^a, each disposed to swing in an approximately horizontal plane. Each of the levers 4-4^a is connected

with suitably guided flexible members 5 which are placed under tension by weights 6. It will be seen that the guard rail 3 with its related parts is placed adjacent to the south rail of the track at the east end of the curve while the guard rail 3^a and related parts is placed at the west end of the curve and adjacent to the north rail of the track. Adjacent to the south rail of the track, and to the west of the curve is placed a guard rail 8, and another guard rail 8^a is placed adjacent to the north rail of the track and to the east of the curve. Upon these guard rails, at the ends of said rails which are near the curve, are pivoted levers 9-9^a with which are connected flexible members 10 which are under tension by weights 11 whereby the levers are moved in the direction of the track rails adjacent to which the guard rails carrying said levers are placed. By this arrangement it will be seen that two guard rails are placed adjacent to one of the track rails, with the curve B intervening while two other guard rails are placed adjacent to the opposite track rail with the curve intervening.

A suitably guided flexible connecting member 12 connects the free ends of the levers 4 and 9 which are pivoted upon the guard rails 3 and 8 adjacent to the south rail of the track; said flexible element being guided beneath the north rail and adjacent to the north side of the latter. In like manner a flexible element, suitably guided, connects the free ends of the levers 4^a and 9^a which are pivoted upon the guard rails 3^a and 8^a adjacent to the north rail of the track, said flexible element being guided beneath the south rail of the track and south of the latter. Each of the flexible elements includes a plurality of bell cranks 14, arranged wherever needed to enable the curve to be rounded; and each of said flexible elements is wound upon a plurality of vertically disposed posts or uprights 15, disposed at suitable intervals in bearings as shown at 16 in Fig. 2 of the drawings; said posts carrying at their upper ends signals such as lanterns 17 which, by rocking the posts in their bearings may be turned so as to expose different sides to approaching trains.

It will be seen from the foregoing description that the levers pivoted upon the guard rails adjacent to the south rail of the track will be adapted to be operated by means connected with a train approaching the curve from the east, while the levers pivoted upon the guard rails adjacent to the north rail of the track will be adapted to be operated by means connected with the train approaching the curve from the west. It will further be noticed that the relative arrangement of the levers and the flexible connecting means is such that when the free end of the lever at one end of the flexible connection is swung outward in the direction of the middle of the track, the other lever will be swung in the direction of the guard rail upon which it is piv-

oted. Normally the free ends of the levers 4 and 4^a which are distant from the curve will be positioned in the direction of the middle of the track in the path of the operating means connected with approaching trains, which I will now proceed to describe.

Upon an axle 18, which may be one of the axles of an engine tender is placed a disk or wheel 19, said wheel being disposed to one side of the longitudinal center line of the truck, so that it will engage the lever 4 or 4^a as the train approaches the curve from either end. Assuming, for the purpose of illustration that a train approaches the curve from the east; the wheel 19 will engage the lever 4 and rock the latter upon its fulcrum, thus exerting tension upon the flexible member 12 and through the latter upon the lever 9, which latter will be moved into the path of the wheel 19 of the approaching train, as shown in Fig. 1 of the drawings. By the movement of the flexible member 12, the posts 15 upon which said flexible element is wound will be rocked a sufficient distance to expose a danger signal to a train approaching the curve from the opposite or west end. When the lever 9 is actuated by the train, the curve has been passed, and the view of the track ahead will be unobstructed; by contact with the lever 9, the operating wheel 19 rocks said lever and restores the mechanism, including the signals to its original or normal position.

It will be seen that by this simple mechanism, the approaches to a curve will be efficiently guarded; danger signals being automatically exposed to trains approaching from either direction by the action of operating means connected with trains approaching from the opposite directions. The mechanism will also be automatically recessed, and will require no manual

attention. The improved signal may be constructed and installed at a moderate expense and, after installation, may be operated practically without further expenditure.

The improved device is simple, and thoroughly efficient and practical for the purposes for which it is devised.

Having thus fully described the invention, what I claim as new is:—

1. A railroad signal including guard rails placed adjacent to a track rail, levers pivoted upon said guard rails at the ends of said rails pointing to an approaching train, suitably guided flexible elements under tension connected with said levers and tending to move them in the direction of the line rail adjacent to which the guard rails are disposed, a suitably guided flexible element extending beneath the opposite line rail guided adjacent to the latter, vertical posts supported for oscillation and carrying suitable signals said posts being engaged and actuated by the flexible element, and lever operating means connected with an axle of a railroad train to one side of the longitudinal center line; the levers being so disposed and connected by the flexible element that only one of said levers shall be exposed in the path of the operating mechanism at any one time.

2. In a railroad signal of the character described, a pair of guard rails, levers pivoted upon said guard rails and adapted to swing horizontally above the guard rails, vertically disposed signal carrying posts mounted for oscillation, a flexible element, suitably guided, and wound upon the signal carrying posts, and means for placing the levers and the flexible connecting element under tension.

In testimony whereof, I affix my signature in presence of two witnesses.

ALBERT HAUTY.

Witnesses:

JOHN MARTIG,
LOUIS RUBIN.