



(86) Date de dépôt PCT/PCT Filing Date: 2007/05/08
 (87) Date publication PCT/PCT Publication Date: 2007/11/22
 (85) Entrée phase nationale/National Entry: 2008/11/12
 (86) N° demande PCT/PCT Application No.: EP 2007/004052
 (87) N° publication PCT/PCT Publication No.: 2007/131668
 (30) Priorité/Priority: 2006/05/12 (DE10 2006 022 155.9)

(51) Cl.Int./Int.Cl. *B65G 59/02* (2006.01),
B65G 61/00 (2006.01)
 (71) Demandeur/Applicant:
KUKA ROBOTER GMBH, DE
 (72) Inventeurs/Inventors:
BAUMANN, MICHAEL, DE;
FELLNER, HERBERT, DE
 (74) Agent: SMART & BIGGAR

(54) Titre : PROCÉDE ET DISPOSITIF PERMETTANT DE PRELEVER DES EMBALLAGES SECONDAIRES EMPILES SUR UNE PALETTE

(54) Title: DEVICE AND METHOD FOR DEPALLETIZING STACKED BUNDLES

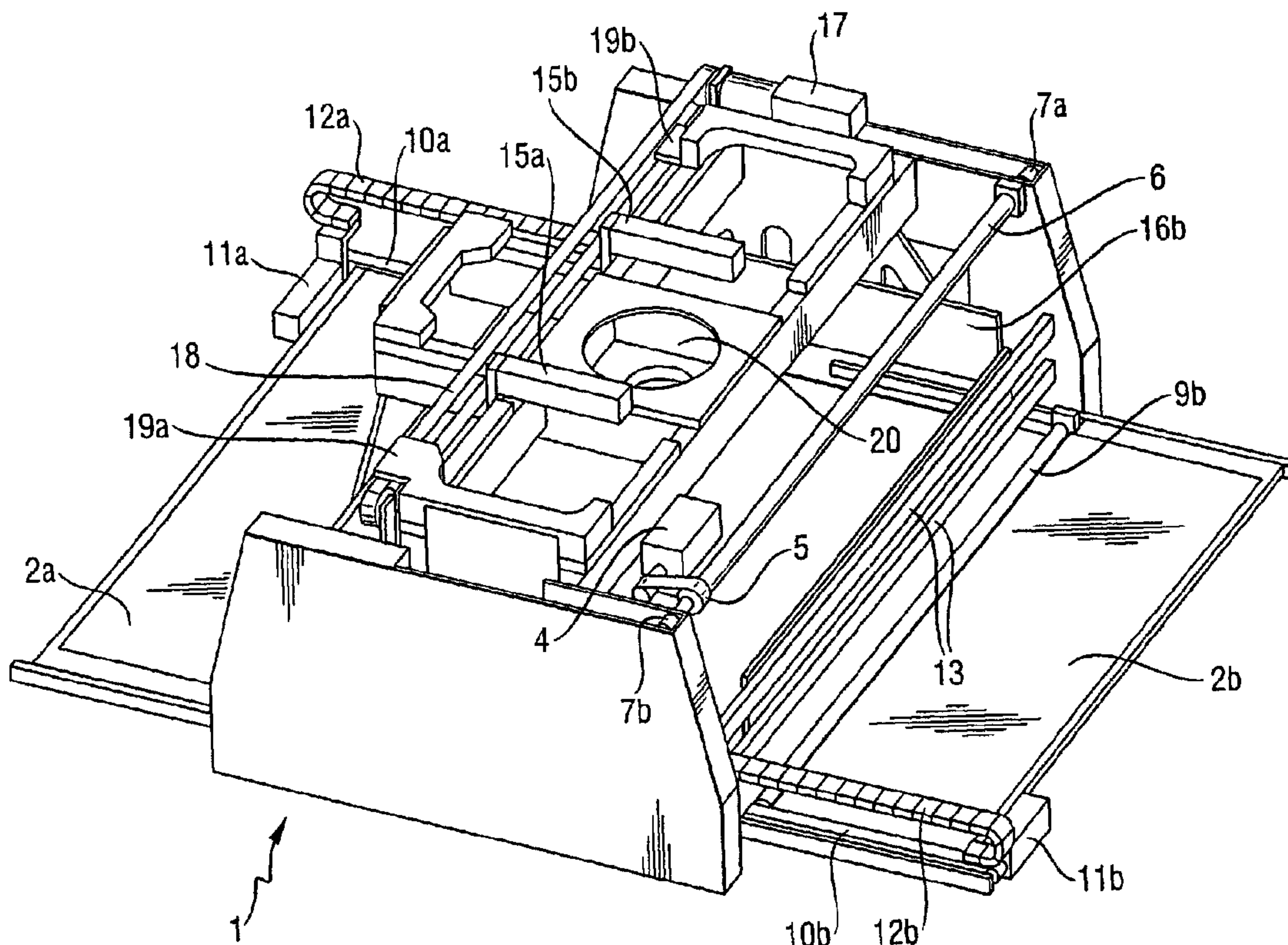

(57) **Abrégé/Abstract:**

According to the invention, the depalletising of stacked bundles may be improved by means of a method for depalletising stacked bundles, wherein bundles are lifted by a frictional engagement and at least one support base is passed beneath the same, wherein the bundle is lifted on two opposing sides. Furthermore, a device for depalletising stacked bundles is disclosed, comprising at least one roller (9a, 9b) for lifting the bundle and a support base (2a, 2b), characterised in having at least two opposing rollers.

ABSTRACT

According to the invention, the depalletising of stacked bundles may be improved by means of a method for depalletising stacked bundles, wherein bundles are lifted by a frictional engagement and at least one support base is passed beneath the same, wherein the bundle is lifted on two opposing sides. Furthermore, a device for depalletising stacked bundles is disclosed, comprising at least one roller (9a, 9b) for lifting the bundle and a support base (2a, 2b), characterised in having at least two opposing rollers.

DEVICE AND METHOD FOR DEPALLETIZING STACKED BUNDLES

The invention concerns a method for depalletizing stacked containers, wherein containers are lifted in a frictionally engaged manner and are underridden by at least one support floor, as well as a device for depalletizing stacked containers, with at least one roller to lift the containers and with a support floor.

The invention in particular concerns the depalletizing of containers stacked on a pallet

10

Individual goods or connected goods containers are typically stacked in multiple layers on a palette and are arranged there for a transport. Given homogeneous palletizing, identical goods (such as beverage containers, for example) are stacked on the pallet. Given mixed palletizing, different goods or goods containers are arranged on a single palette. This is also called mixed commissioning. A widespread application is the arrangement of a mixed pallet of goods based on an order of a retailer with a distributor. The goods ordered by retailer are assembled from a storage of the distributor. The desired goods are thereby removed from homogeneous pallets and individually assembled on a delivery pallet according to the customer order. The mixed, commissioned pallet is then delivered to the buyer, i.e. delivered to the retailer.

US 4,453,874 shows a device according to the species, with a grabber on whose front, free end are mounted rotatable rollers. The rollers serve to lift the goods to be taken on one side by means of frictionally engaged contact with a side surface of said goods, such that they can be loaded onto a support floor of the grabber that can be moved under the goods for this. Alternatively, a conveyer belt can be provided at the grabber, with which the goods can be transported on said grabber. The rollers can be provided with a friction-increasing relief or a coating; for example, they can be fashioned rubberized. The taken goods package can subsequently be deposited again on another pallet in the reverse order. Such

-2-

grabbers are generally permanently installed in a system or are mobile, directed via a portal system.

5 It is disadvantageous that only one single-sided action on the goods is possible, such that a brace is necessary and – since the goods are tilted upon lifting and the distance between brace and lifting roller increases – either the brace or the lifting roller must be elastically arranged, wherein a difficult coordination is to be conducted between elastic yielding force and friction coefficient of the roller.

10 DE 37 18 601 A1 shows a depalletizing tool that is mounted on an articulated robot. The tool possesses rigid, blade-like pickup tongues that can engage below and lift the goods packages. US 2002/0154986 A1 possesses a lifting plate with very low height that can be slid between layers of goods, thereby raises the upper
15 package. This tool can also be attached to a robot.

Depalletizing tools known from the prior art also exhibit the disadvantage that the depalletizing process can be sensitively disrupted or, respectively, hindered by a presence of loose objects arranged on the top of a container unit (for example
20 coverings or cover layers in the most varied embodiments or materials). For example, a sliding or canting of such objects during an unloading process can lead to a complete operational failure of a of a known depalletizing tool, with a significant time and repair cost connected with this.

25 The invention is based on the object to reliably and safely depalletize products in the most varied pakkaging [sic] forms, starting from the aforementioned prior art while avoiding the cited disadvantages.

30 According to the invention, the cited object is achieved in a method of the aforementioned type in that the containers are lifted on two opposite sides.

Accordingly, a device according to the species provides at least two opposite rollers to achieve the cited object.

5 Via the invention, a safe and reliable lifting of containers stacked for removal is enabled in that the containers are attacked in a frictionally engaged manner on at least two opposite sides. The containers are hereby on the one hand lifted in alignment parallel to the container layers (in particular vertically); on the other hand, a higher reliability is achieved in that two opposite sides are attacked in a frictionally engaged manner. Moreover, a difficult coordination between friction
10 coefficient of the lifting elements (such as flat rollers and horizontals of this yielding or elastic force pressing against the containers) is avoided relative to the aforementioned prior art since the lifting elements can be pressed against the containers with such a maximum force that is so large that it only does not damage the containers [sic].

15

According to a preferred development of the method according to the invention, it is provided that the containers are lifted by means of rollers that rotate for this, wherein in particular the – lifted – containers are underridden with a respective support floor part from at least two sides. The underriding thereby in particular
20 ensues from two opposite sides.

Accordingly, a development of the device according to the invention provides that the support floor possesses at least two support floor parts that can be moved against one another. On the one hand, a symmetrical embodiment of the device
25 according to the invention is hereby achieved. This is therefore not excessively unloaded on one side. Moreover, the pick-up and gripping of the containers is hereby likewise improved and provided with greater safety. While (in principle) two support floor parts (thus two support floor halves) that can be moved against one another can be provided, four support floor parts can also be provided that are
30 fashioned in triangle or tongue shapes, wherein two respectively move perpendicular to the other two.

Developments of the device according to the invention provide that the rollers can be driven by at least one roller drive motor, wherein in particular the rollers can be driven via belts from at least one roller motor.

5

To move the plates, in a preferred embodiment it can be provided that the support floor parts can be shifted via carriers, wherein in particular the support floor parts can be shifted again by means of drive belts (if necessary via the carriers). In a development, it can thereby in particular be provided that the support floor parts
10 can be shifted via at least one distributor shaft, wherein the distributor shaft can furthermore be driven by at least one motor via at least one synchronous belt.

In order to also take up the containers in a direction perpendicular to the stops, in a preferred embodiment a centering device is provided that in particular is designed
15 such that at least one slider plate that can be shifted parallel to the extension [sic] direction of two rollers is provided to center the containers, wherein furthermore two slider plates that can be displaced against one another can be provided. A concrete embodiment thereby provides that the slider plates can be shifted via at least one centering motor (advantageously via synchronous belts), wherein in
20 particular the slider plates can be moved synchronously. In a preferred manner, the device according to the invention can possess a connection coupling for connection with a robot, as this is known from the prior art.

In order to furthermore achieve an increased operating safety during the
25 depalletizing process, it is proposed that at least one hold-down clamp acts on the top of the container. According to the invention, a slipping or, respectively, canting of objects arranged on the top of the container unit but not fixed to said container unit can thereby be reliably prevented. These can thereby in particular be loosely positioned covers or liners in different embodiments or materials, as
30 they are typically arranged on the surface of containers for protective purposes.

In regards to a device, to solve this problem the invention provides that a hold-down clamp is arranged on the top of the container. Such a hold-down clamp is preferably fashioned essentially in the shape of a plate. On the one hand, it can thereby be achieved that the hold-down clamp covers the entire top side of a
5 container; on the other hand, it remains simple to position.

In a preferred embodiment, such a hold-down clamp is furthermore fashioned to be flexible, such that it can essentially be adapted to the surface shape of the container. A particularly high degree of operating safety can thus also be achieved
10 in the case of individual objects arranged on specific sub-regions of the surface since, according to the invention, a securing essentially along the entire container top is thus ensured. For example, it can thereby be provided that the hold-down clamp is formed from a chain-shaped material, in particular flat-top chains made from plastic or metal. The hold-down clamp can likewise be formed from rug-
15 shaped, plaited material, in particular wire or fabric. Such a material choice according to the invention enables an adaptation of the hold-down clamp to the respective contours of a respective container layer.

Alternatively, the hold-down clamp can also be fashioned to be rigid. A
20 particularly high contact pressure force of the hold-down clamp on the surface of the container can thus be achieved. Additional embodiments of the hold-down clamp provide an even-surfaced or slack design.

To achieve a particularly simple positioning of the hold-down clamp, it is proposed
25 that the hold-down clamp can be moved vertically from an upper position into a lower position. The lower position preferably corresponds to that position in which the hold-down clamp comes into frictionally engaged contact with the surface of the container top. A use of the hold-down clamp as necessary is also possible. If the hold-down clamp should not be necessary, it is provided that it
30 remains in its upper position upon implementation of the method according to the invention.

In a preferred embodiment, the hold-down clamp can travel continuously; in particular the travel height or, respectively, width can be continuously adjusted. The hold-down clamp is thereby preferably guided by linear units, whereby a
5 precise movement is enabled as necessary. In particular, it can be provided that the linear direction of the hold-down clamp ensues at its respective sides or, respectively, corners, in particular on four sides. A precise, switchable embodiment of a hold-down clamp thereby provides that this can move in a pneumatic and/or motorized manner.

10

Additional advantages and features of the invention result from the Claims and from the subsequent specification, in which an exemplary embodiment of the invention is explained in detail with reference to the drawings. Thereby shown are:

15

Fig. 1 a perspective representation of a device according to the invention, at a robot attacking a container stack;

20

Fig. 2 the preferred embodiment of the device according to the invention in a perspective depiction, angled from above;

25

Fig. 3 the embodiment according to the invention of the device according to the invention in perspective depiction, angled from below in the open state;

Fig. 4 an additional perspective representation of the device according to the invention in an open state;

30

Fig. 5 a perspective depiction of the preferred embodiment of the device according to the invention in a closed state, angled from above;

-7-

- Fig. 6 an additional perspective representation of the device according to the invention in a closed state, angled from below;
- Fig. 7 a vertical section through the device according to the invention in a closed state;
- Fig. 8 a vertical section through the device according to the invention in an open state;
- Fig. 9 a perspective depiction of a device according to the invention in a side view, wherein parts of the base frame are removed so that the internal area with a hold-down clamp according to the invention is visible, by which hold-down clamp the surface of a container stack is covered;
- Fig. 10 the device according to the invention as shown in Fig. 9, in a corresponding side view without a container stack protruding into the internal space; and
- Fig. 11 an additional perspective depiction of the device according to the invention, angled from above.

Fig. 1 is an overview representation in which a device according for depalletizing according to the invention is connected with a robot that encompasses the uppermost layer of a container stack located on a pallet in order to lift this from the remaining stack.

The device for depalletizing according to the invention is described in detail in the following using additional Figures.

30

The depalletizing tool according to the invention possesses a base frame 1 on whose underside two support floor parts 2a and 2b (here as support floor halves) can be moved towards and away from one another by means of slide bearings 3a, 3b. For an automatic movement of the support floor parts 2a and 2b, a common
5 electrically drivable motor 4 is provided that drives (via a first synchronous belt 5) a distributor shaft 6 which drives a right drive belt 7a and a left drive belt 7b. The drive belts 7a and 7b are for their part connected with a carrier 8a and 8b that are in turn respectively connected with one of the two support floor parts 2a and 2b. However, the support floor parts 2a and 2b could also be moved independent of
10 one another if two motors controllable independent of one another were provided, which, however, is not the case in the realized embodiment. A roller 9a and 9b are respectively rotatably borne on the inner, facing longitudinal edges of the support floor parts 2a and 2b. Such rollers can, for example, be realized in the form of rotating, rubberized rollers via which a frictionally engaged force transfer is
15 enabled. Each roller 9a, 9b is connected via an additional belt 10a and 10b with an associated roller drive motor 11a and 11b. The shaft drive motors 11a and 11b are connected with a drive controller (not shown) via electrical lines that are directed with low wear within power track chains 12a and 12b.

20 A fixed stop is designated with the position number 13, against which stop the depalletized goods are shifted together by a movable stop 14, counter to the movement direction of the support floor parts 2a and 2b. The movable stop 14 is moved by means of two cylinders 15a and 15b charged with pressurizing medium. The cylinders 15a and 15b are executed as compressed air cylinders that can be
25 charged with compressed air via electrically activatable valves (not shown).

The collected goods can be centered at a right angle to the movement direction of the support floor parts 2a and 2b and perpendicular to the first centering direction by means of an additional centering device that possess [sic] two opposite,
30 movable slide plates 16a and 16b. The slide plates 16a and 16b are moved jointly and in sync by means of a centering motor 17 that is coupled with an additional

synchronous belt 18 that for its part are [sic] connected with two connection parts 19a and 19b. One connection part 19a and 19b is respectively, permanently connected with one of the slide plates 16a and 16b so that the two slide plates 16a and 16b are synchronously moved towards or away from one another (depending
5 on the rotation direction of the centering motor 17) upon driving the synchronous belt 18.

The surfaces of the support floor parts 2a and 2b are produced from gliding stainless steel plates. The stainless steel plates are stamped or deformed with
10 knobs or ridges to reduce the contact surface with the arranged goods. Alternatively, the surfaces of the support floor parts 2a and 2b can also be equipped with actively drivable conveyor belts or with passive track rollers.

For a positioning of the depalletizing tool at the exact height on a plane between
15 two layers of goods or goods containers, light barriers are provided as sensors that can detect not only the boundary plane between two goods layers but also an interstice between two goods or goods containers in the movement direction of the support floor parts 2a and 2b in the same plane. For this, the sensors for detection of the interstice between two goods or goods containers can be arranged at the
20 forward end of the support floor parts 2a and 2b, i.e. in proximity to the rollers 9a, 9b. Either these sensors can additionally detect the height of the layer, or separate sensors can be provided for this that, for example, are attached to the base frame 1 of the depalletizing tool.

25 A connection of the device according to the invention with a robot is possible via a connection coupling 20 arranged on the top side.

To pick up the uppermost container of a container stack (as this is presented in Fig. 1), the robot bearing the device according to the invention lowers said device over
30 the stack so that the rollers 9a, 9b come to lie in the lower region of the uppermost layer or of the upper container. They are then moved against the container together

-10-

with the support plates 2a, 2b. They are subsequently connected in the opposite direction [sic] and non-positively lift the container until this arrives with its lower edge in the upper region of the rollers 9a, 9b, whereupon these can travel under the container together with the support plates as this is presented in Fig. 5, 6 and 7.

5 After the support plates 2a, 2b have reliably engaged below the container, the robot can lift this from the stack (by means of the device 1 according to the invention that is connected with said robot) and move said container to a depositing location.

In the perspective view (shown in Fig. 9) of a device according to the invention,
10 side parts of the base frame 1 are not shown so that the internal area is visible. The support floor parts 2a, 2b are thereby located in a position wherein they are moved outward, away from one another, so that the accommodation of a container stack 22 is possible, which container stack 22 protrudes into the internal space of the device.

15

A plate-shaped hold-down clamp 21 is arranged on the top side of the connection stack 22, which hold-down clamp 21 is flexibly adapted to the surface of the container and via which a slipping or, respectively, canting of objects (such as covers or liners) loosely positioned on the top side can be reliably avoided. The
20 hold-down clamp 21 possesses a rectangular shape that essentially corresponds to the area that is formed by the support floor parts 2a, 2b when they are moved together. A complete covering of the top side of the respectively picked-up container layer is thus possible.

25 A respective retention clip 23a, 23b, 23c, 23d via which the hold-down clamp 21 is respectively coupled to one of four linear guides 25a, 25b, 25c, 25d by means of a fastener 24a, 24b, 24c, 24d is located at the four corners of said hold-down clamp 21. The linear guides 25a, 25b, 25c, 25d are essentially formed by rails arranged at the respective side edges of the device according to the invention and extending
30 perpendicular to the surface of the hold-down clamp. A continuous, electrically or pneumatically driven lowering or, respectively, raising of the hold-down clamp 21

-11-

onto or, respectively, from the top of the container stack is thus possible. The use of the hold-down clamp 21 can thereby ensue as necessary. For example, a lowering of the hold-down clamp 21 onto the top side of the container stack 22 can be provided only in the event that loose material is present by which the loading or, respectively, unloading process could be affected or disrupted.

Under the assumption that the hold-down clamp is required in a loading or, respectively, unloading process, the device according to the invention is positioned above the uppermost container layer. A lowering of the hold-down clamp 21 onto the top side of the container unit 22 ensues in the next step. In the following step, a raising of the uppermost container layer ensues via the rollers 9a, 9b in the manner described in the preceding, such it is possible for the support plates 2a, 2b to move under the container. During this step, loosely positioned objects (such as covers or liners) are fixed or, respectively, held in position by the hold-down clamp positioned on the top.

In the following step, a pick-up of the layer in the device according to the invention is brought about by the robot, which in turn produces a repositioning of said layer, for example to another pallet or a subtraction table. The hold-down clamp also remains in position on the top side of the container layer during the step of the release of said container layer, and only travels back into its upper, starting position again after the release process of the container layer.

Reference list

	1	base frame
	2a, 2b	support floor parts
5	3a, 3b	slide bearings
	4	motor
	5	synchronous belt
	6	distributor shaft
	7a, 7b	drive belt
10	8a, 8b	carrier
	9a, 9b	roller
	10a, 10b	belt
	11a, 11b	roller drive motor
	12a, 12b	power track chains
15	13	fixed stop
	14	movable stop
	15a, 15b	cylinder
	16a, 16b	slide plate
	17	centering motor
20	18	synchronous belt
	19a, 19b	connection parts
	20	connection coupling
	21	hold-down clamp
	22	container stack
25	23a, 23b, 23c, 23d	retainer clip
	24a, 24b, 24c, 24d	fastener
	25a, 25b, 25c, 25d	linear guide

Patent claims

1. Method for depalletizing stacked containers, wherein containers are lifted in a frictionally engaged manner and are underridden by at least one support floor, characterized in that the containers are lifted on two opposite sides.
5
2. Method according to Claim 1, characterized in that the containers are lifted by means of rollers.
10
3. Method according to Claim 1 or 2, characterized in that the lifted containers are underridden by two support floors from opposite sides.
4. Method according to any of the Claims 1 through 3, characterized in that at least one hold-down clamp (21) acts on the top of the container (22).
15
5. Device for depalletizing stacked containers, with at least one roller to lift the container, and with a support floor, characterized by at least two opposing rollers (9a, 9b).
20
6. Device according to Claim 5, characterized in that the support floor possesses at least two support floor parts (2a, 2b) movable against one another.
- 25 7. Device according to Claims 5 or 6, characterized in that the rollers (9a, 9b) can be driven by at least one roller drive motor (11a, 11b).
8. Device according to Claims 7, characterized in that the rollers (9a, 9b) can be driven via belts (10a, 10b) by at least one roller motor (11a, 11b).
30

-14-

9. Device according to any of the Claims 5 through 8, characterized in that the support floor parts (2a, 2b) via carriers (8, 8a).
10. Device according to any of the Claims 5 through 9, characterized in that the support floor parts (2a, 2b) are displaceable by means of drive belts (7a, 7b), possibly via the carriers (8, 8a).
11. Device according to any of the Claims 5 through 10, characterized in that the support floor parts are displaceable via at least one distributor shaft (6).
12. Device according to Claim 11, characterized in that the distributor shaft (6) can be driven by an [sic] at least one motor (4) via at least one synchronous belt (5).
13. Device according to any of the Claims 5 through 12, characterized by a fixed stop (13) and a stop (14) movable relative to this for positioning of the container.
14. Device according to Claim 13, characterized in that the movable stop (14) can be displaced by means of at least one cylinder, advantageously as a compressed air cylinder.
15. Device according to any of the Claims 4 through 13, characterized by at least one slider plate (16a, 16b) displaceable parallel to the extension [sic] direction of two rollers (9a, 9b) to center the container.
16. Device according to Claim 14, characterized by two slide plates (16a, 16b) displaceable against one another.

-15-

17. Device according to Claim 14 or 15, characterized in that the slide plates (16a, 16b) are displaceable via at least one centering motor, advantageously via synchronous belts.
- 5 18. Device according to Claim 15 or 16, characterized in that the slide plates (16a, 16b) can be moved synchronously.
19. Device according to any of the Claims 4 through 17, characterized by a connection coupling (20) to connect the device with a robot.
- 10 20. Device according to any of the Claims 5 through 19, characterized by a hold-down clamp (21) that is arranged on the top of the container (22).
- 15 21. Device according to Claim 20, characterized in that the hold-down clamp (21) is fashioned essentially in the shape of a plate.
22. Device according to Claim 20 or 21, characterized in that the hold-down clamp (21) is fashioned to be flexible so that it can be significantly adapted to the surface shape of the container (22).
- 20 23. Device according to Claim 22, characterized in that the hold-down clamp (21) is formed from chain-shaped material, in particular flat-top chains made from plastic or metal.
- 25 24. Device according to Claim 22, characterized in that the hold-down clamp (21) is formed from rug-shaped, plaited material, in particular wire or fabric.
- 30 25. Device according to Claim 20 or 21, characterized in that the hold-down clamp (21) is fashioned to be rigid.

-16-

26. Device according to any of the Claims 20 through 25, characterized in that the hold-down clamp (21) can be moved vertically from an upper position into a lower position.
- 5 27. Device according to Claim 26, characterized in that the hold-down clamp (21) can travel continuously.
28. Device according to Claim 26 or 27, characterized in that the lower position corresponds to that position in which the hold-down clamp (21) comes into
10 frictionally engaged contact with the surface of the container top (22).
29. Device according to any of the Claims 26 through 28, characterized in that the hold-down clamp (21) is movable in a pneumatic and/or motorized
15 manner.
30. Device according to any of the Claims 20 through 29, characterized in that the hold-down clamp (21) is fashioned to cover the entire top of the
20 container (22).

Smart & Biggar
Ottawa, Canada
Patent Agents

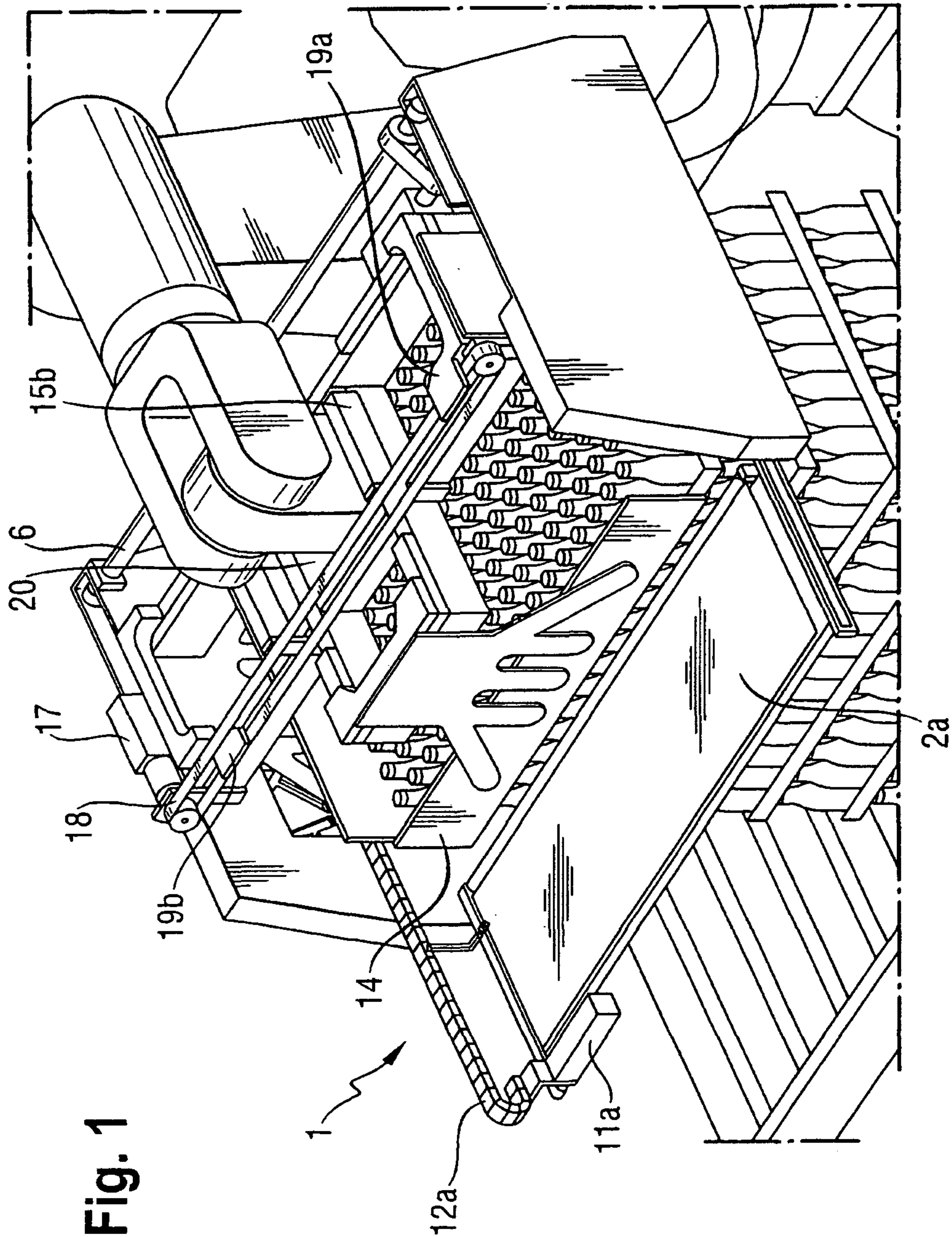

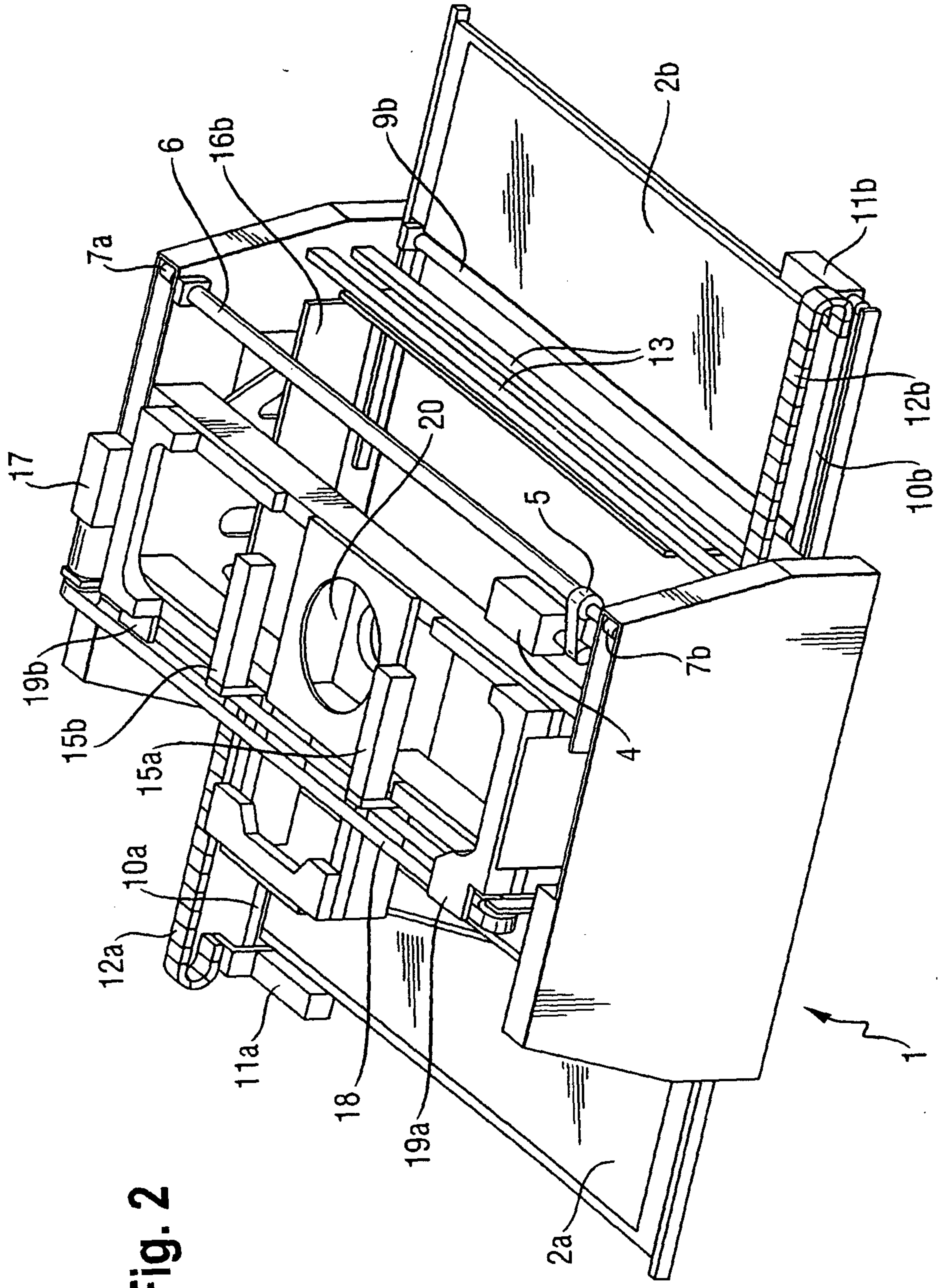

Fig. 2

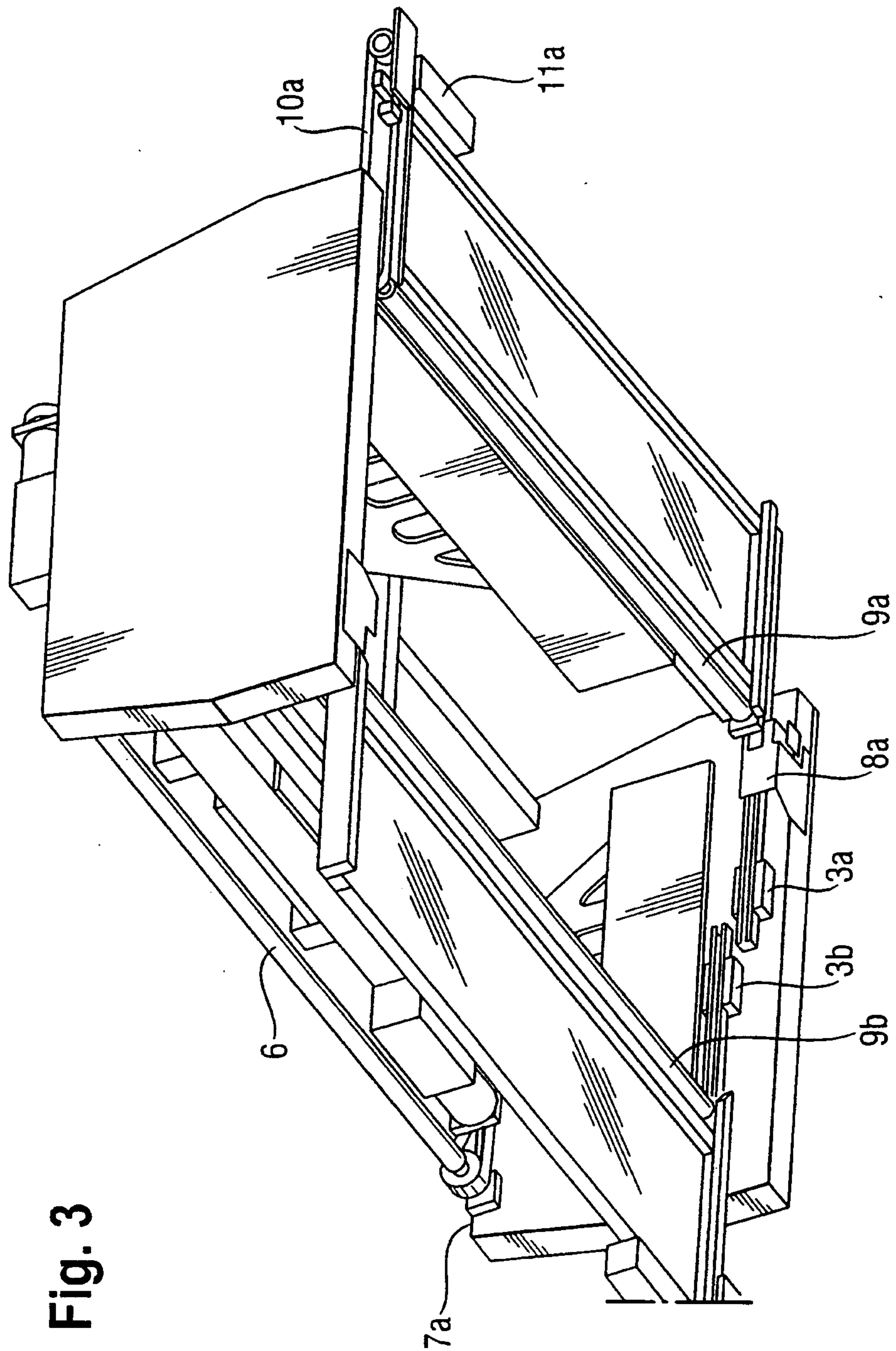
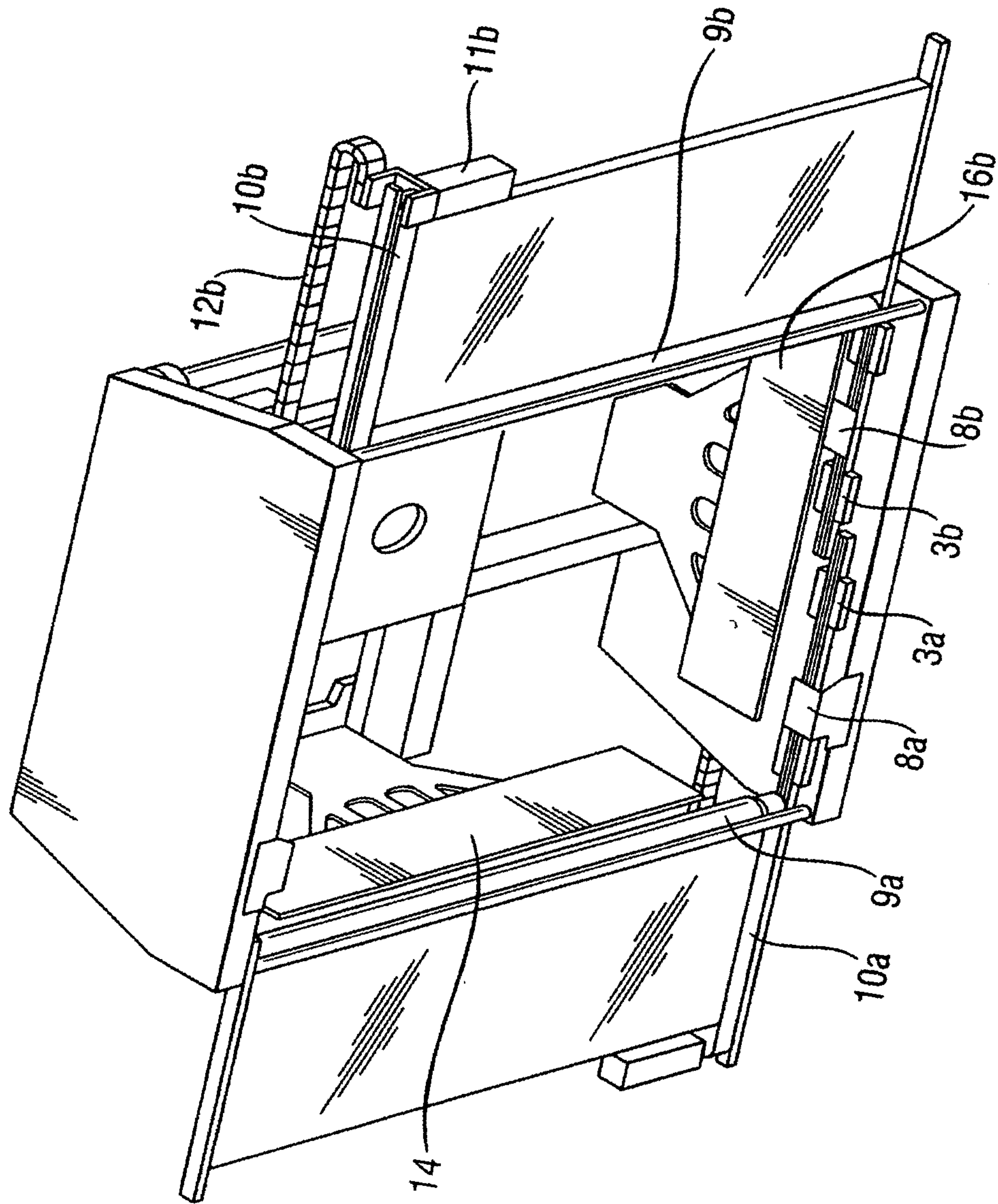
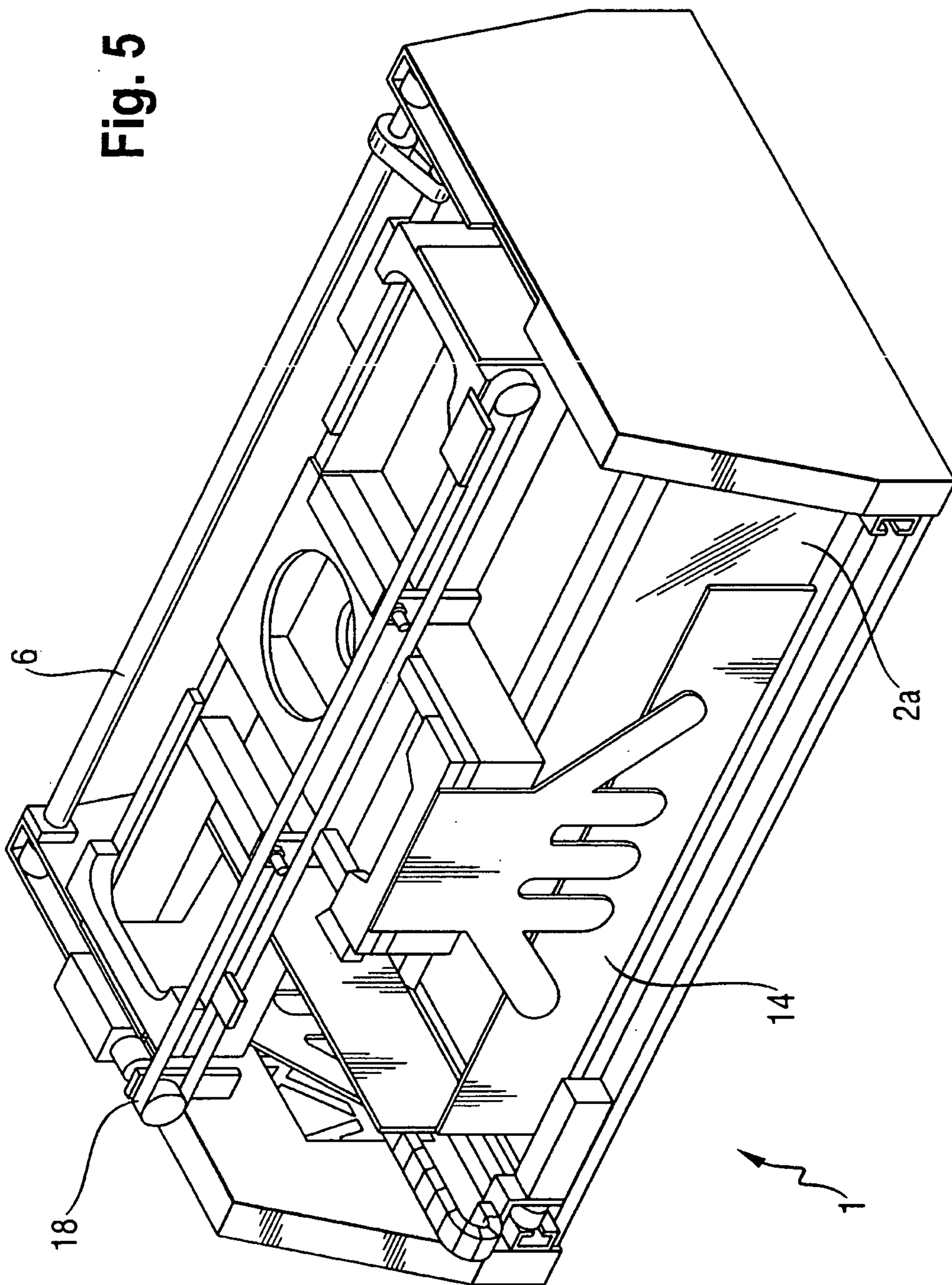

Fig. 3

Fig. 4





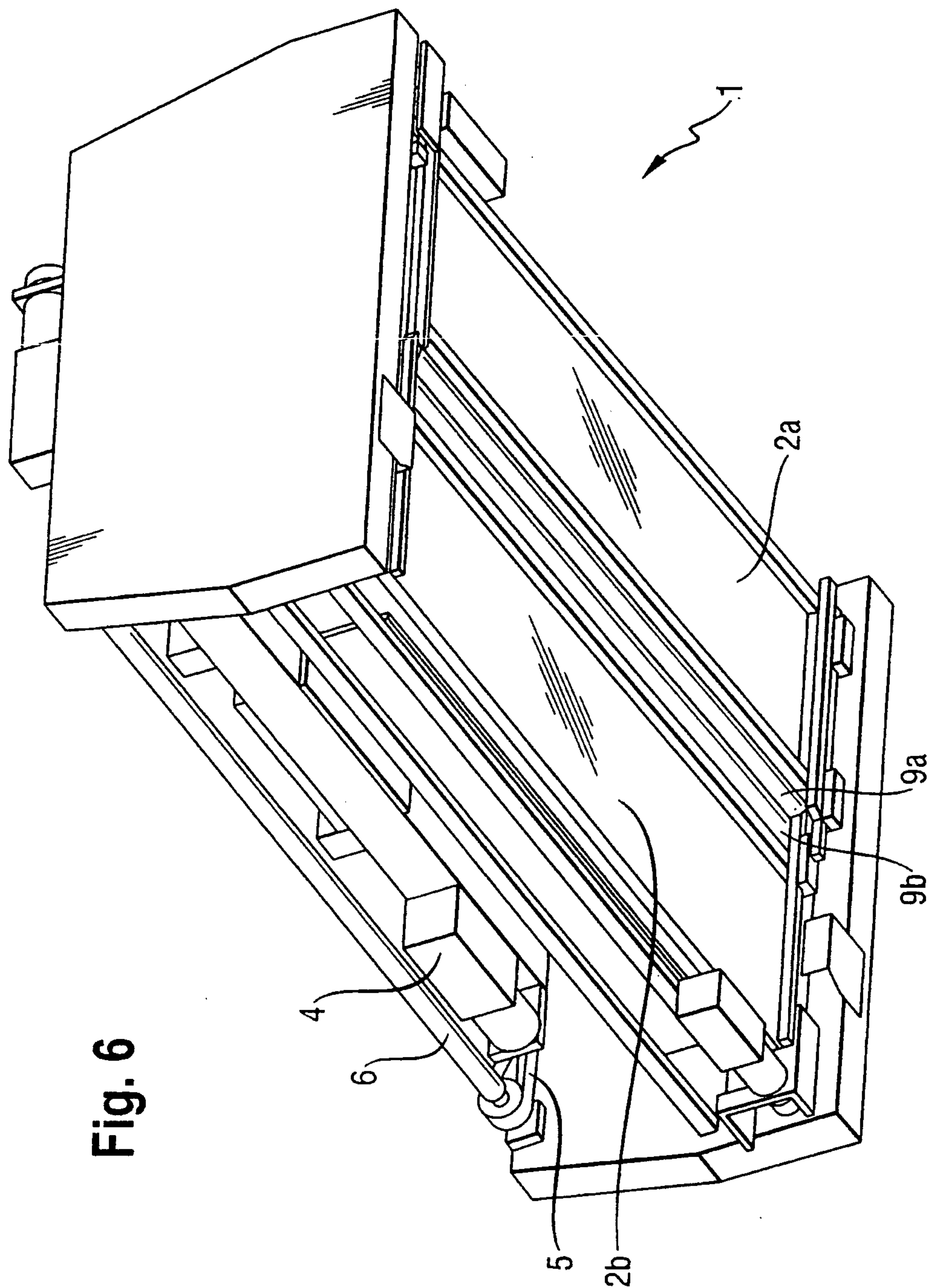

Fig. 6

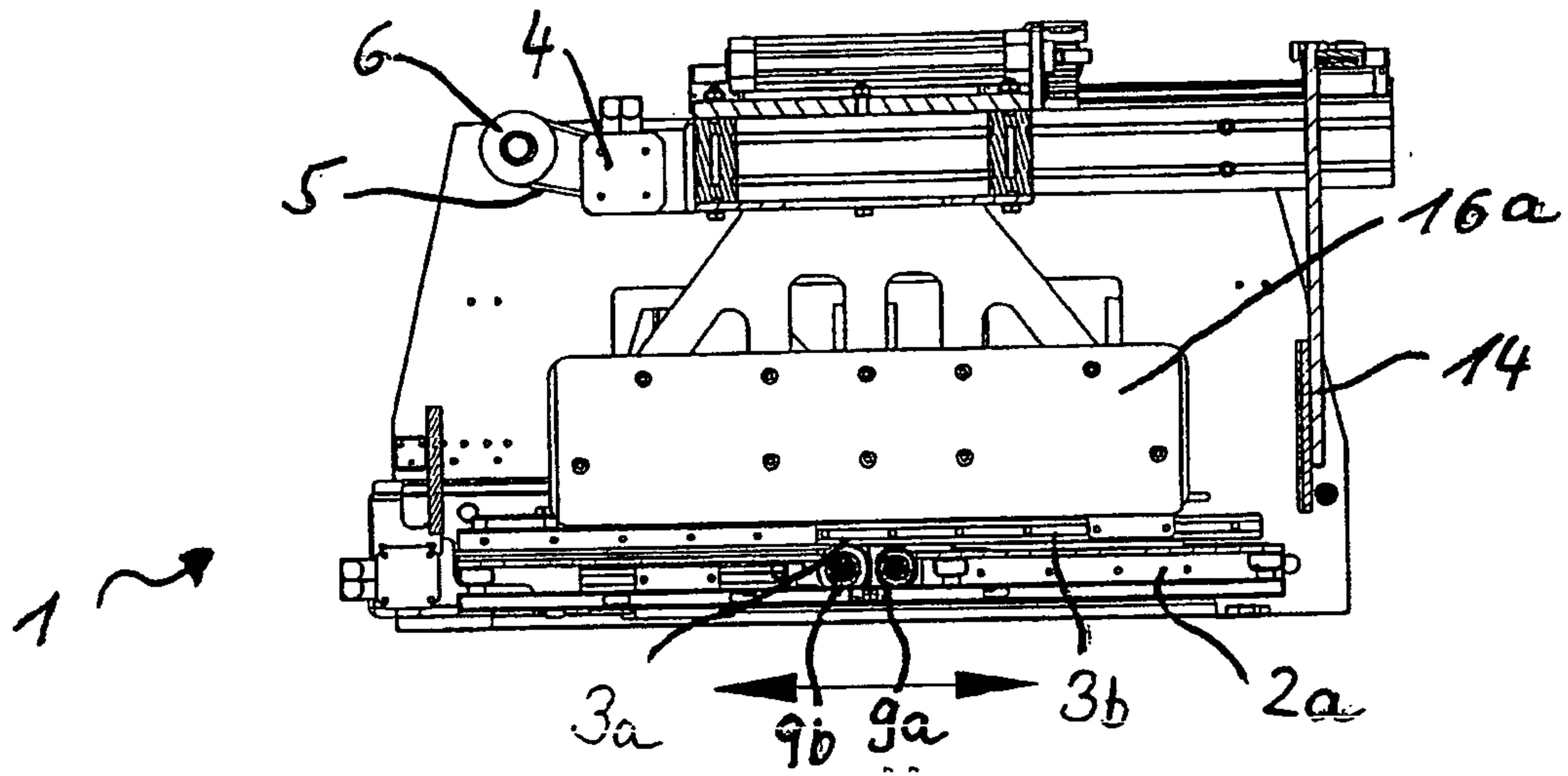

Fig. 7

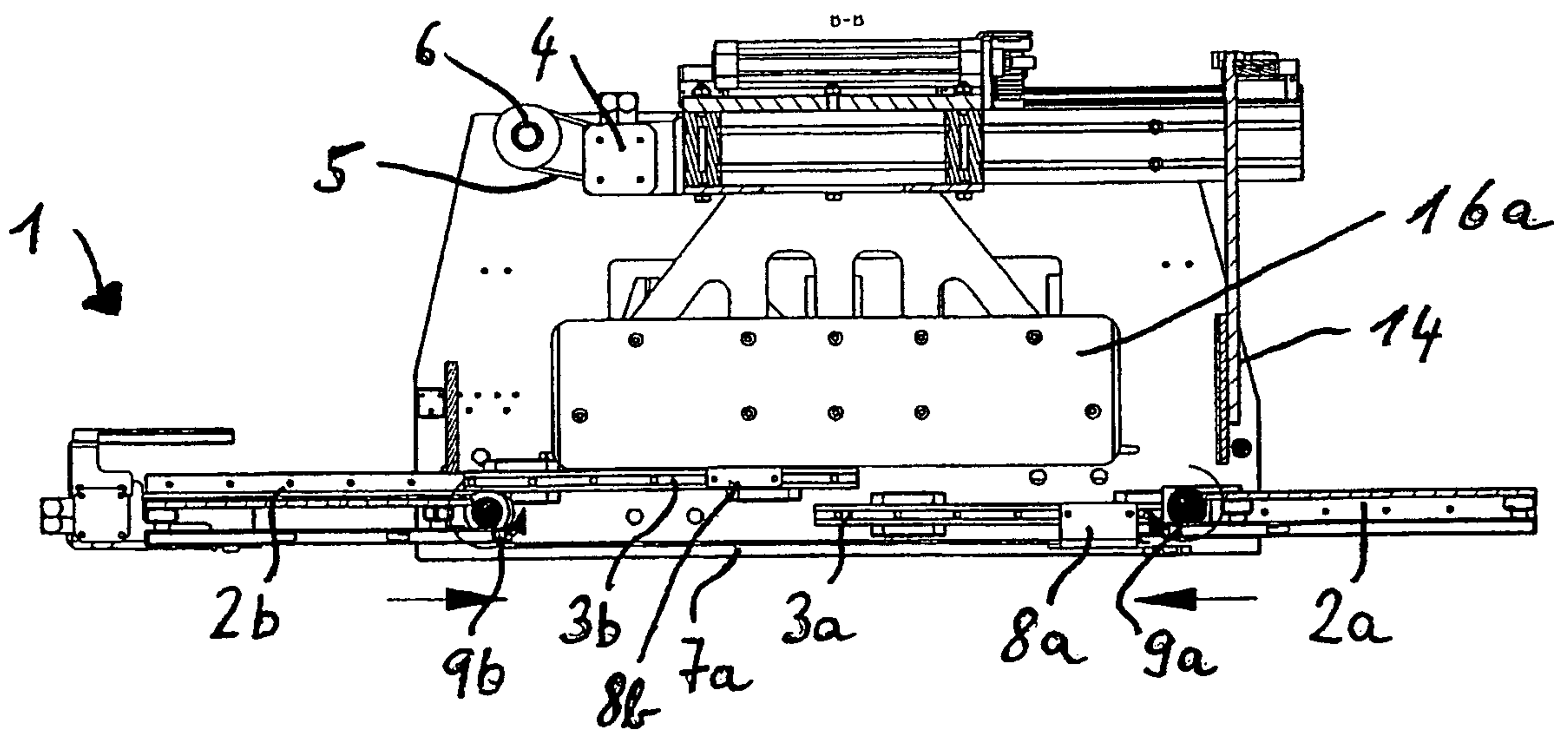

Fig 8

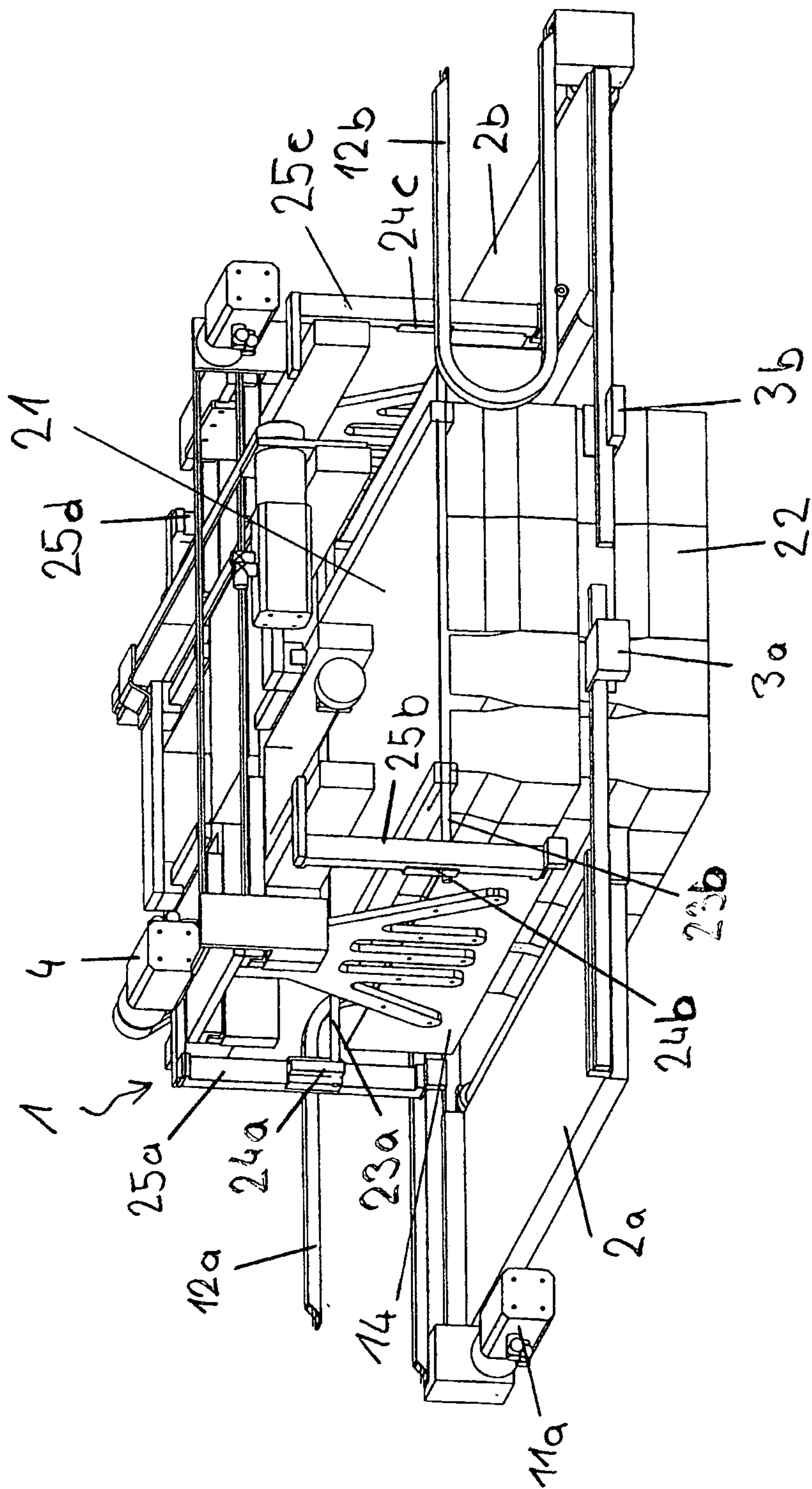

Fig. 9

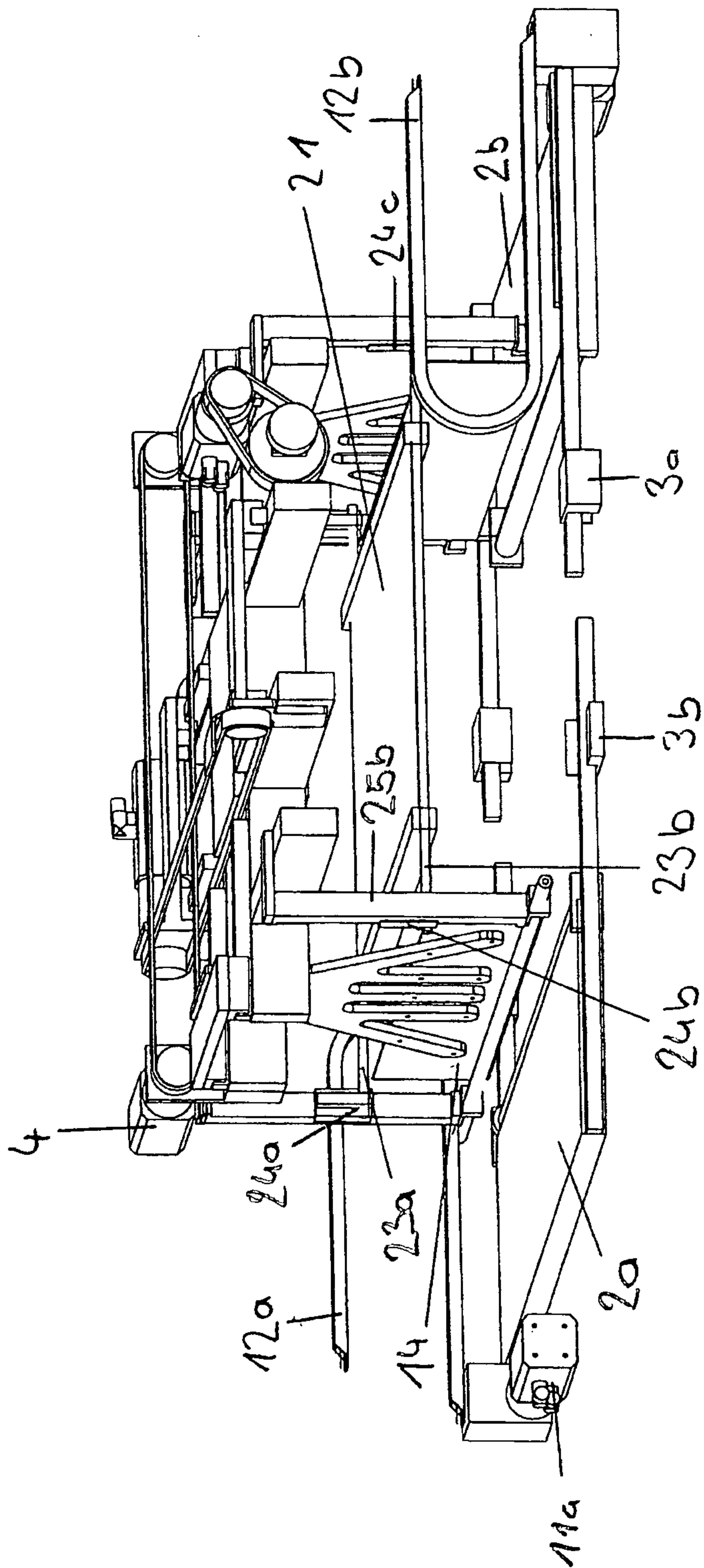

Fig. 10

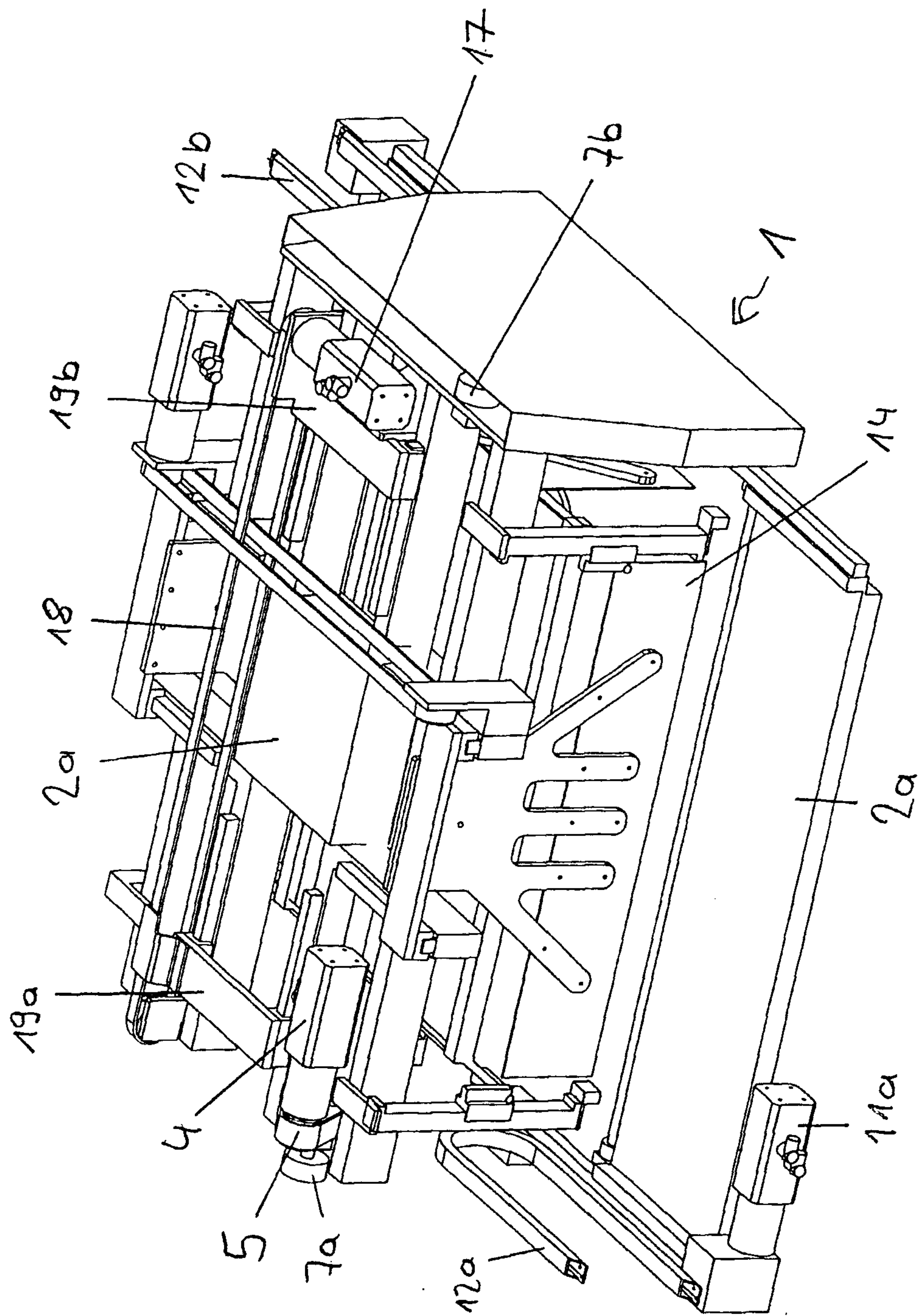

Fig. 11

