

J. A. R. PHIPPS.
MILK BOTTLE HOLDER.
APPLICATION FILED MAR. 30, 1918.

1,298,559.

Patented Mar. 25, 1919.

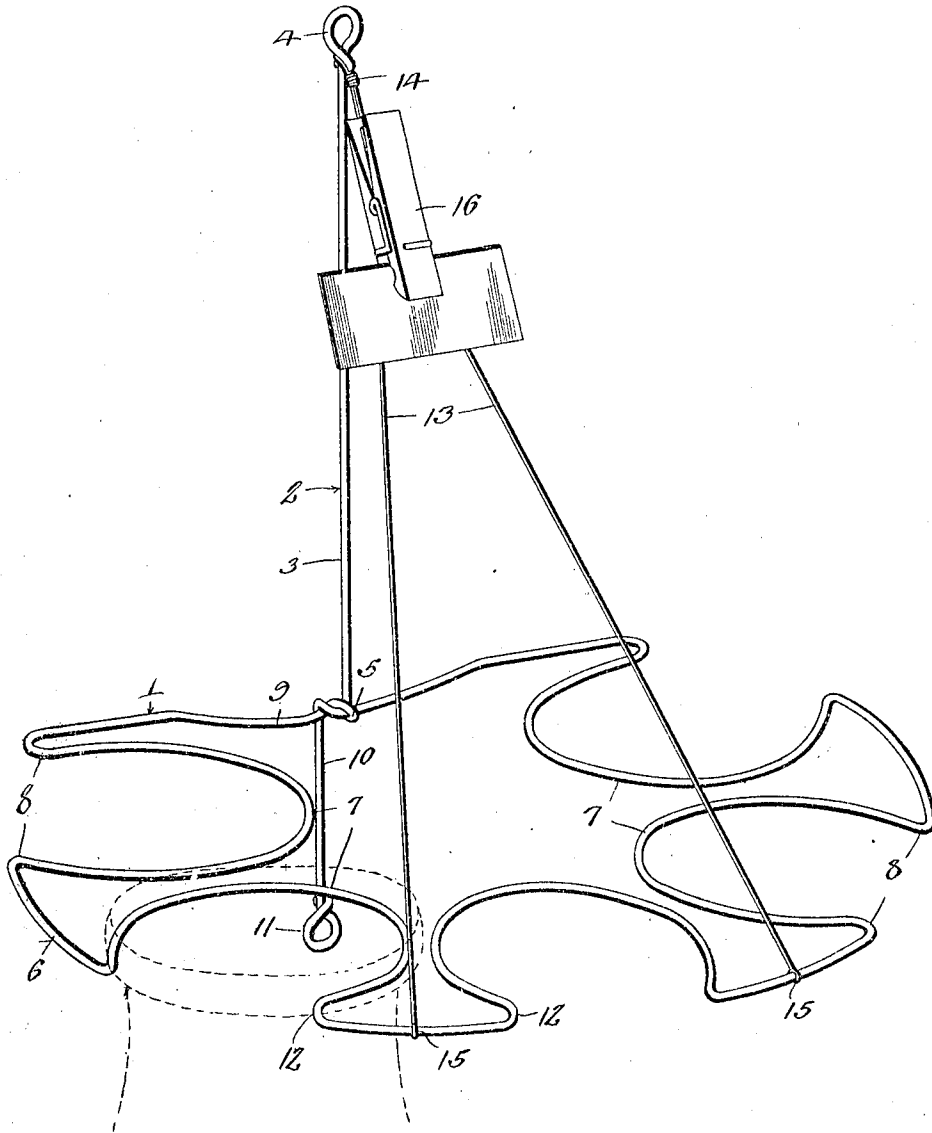

WITNESSES

E. H. Davis

Inventor

J. A. R. Phipps,

By *Victor J. Evans*

Attorney

UNITED STATES PATENT OFFICE.

JAMES A. R. PHIPPS, OF BINGHAMTON, NEW YORK.

MILK-BOTTLE HOLDER.

1,298,559.

Specification of Letters Patent. Patented Mar. 25, 1919.

Application filed March 30, 1918. Serial No. 225,728.

To all whom it may concern:

Be it known that I, JAMES A. R. PHIPPS, a citizen of the United States, residing at 10 Colfax avenue, in the city of Binghamton, in the county of Broome and State of New York, have invented new and useful Improvements in Milk-Bottle Holders, of which the following is a specification.

This invention relates to a holding device for milk bottles, and has for its object to produce an article of this character which is preferably constructed upon a single strand of spring wire, shaped to provide a horizontally disposed body portion or frame and supporting arms therefor, the said frame having its perimeter provided with reëntrant loops which constitute clamps that engage with the necks of bottles and removably hold the bottles on the frame.

It is a further object of the invention to produce a device of this character in which the horizontally disposed body portion of the improvement is integrally formed with spring clamps to engage the necks of bottles, reinforcing means being provided for the said horizontal portion or body, and a clip being arranged upon said reinforcements for holding milk tickets, cards suitably inscribed to indicate to the milkman the required quantity of milk.

It is a further object of the invention to produce a device of this character which shall be of an extremely simple construction, cheap to manufacture and thoroughly efficient for the purpose intended.

Other objects and advantages will appear as the nature of the invention is better understood.

The figure illustrates a perspective view of the improvement.

As disclosed in the drawing the improvement, in the main is constructed of a single strand of bendable wire, and includes a frame 1 and a support therefor which is indicated by the numeral 2. The strand of wire comprising the upper member 3 of the support 2 has its end bent upon itself to provide an eye 4 through which a suitable securing element passes. This strand 3 is further bent upon itself to provide a loop 5 and is thence continued upwardly to its juncture with the frame 1. The perimeter of the frame, indicated by the numeral 6 is

provided with a plurality of equally spaced reëntrant loops 7 of a size to constitute the clamps 8 which engage with the neck portions of the milk bottles, one of which being indicated by the dotted lines in the drawing. The frame 1 is arranged at a right angle with respect to its support 2, and the end strand of the frame is passed through the loop 5, and bent over the lateral extension 9 of the strand 3 outward of its said loop 5, and continued outwardly or in an opposite direction from the strand 3, the last referred to strand being indicated by the numeral 10. The strand 10 at the end thereof is looped or rounded upon itself to provide an eye 11 and through this eye is designed to pass the second securing element for the device.

By reference to the drawing it will be noted that the ends of the clamps 8 are directed toward each other, and the ends or loops 12 of each of the clamps are designed to be spread away when the milk bottle is inserted in the clamp. The milk bottles may be easily inserted and easily withdrawn from the clamps.

The frame 1 is supported on the support 2 preferably through the medium of a comparatively small gage wire 13 which is centrally connected, as at 14 to the eye 4 of the strand 3 and which has its strands extended at opposite angles and wound around or otherwise connected to the perimeter of the frame which is indicated by the numerals 15. The ends of the strands 13 are arranged to the opposite side of the outer and central clamp 8, as clearly illustrated by the drawings. The strands 13 support a spring clip 16, and this clip is designed to hold the milk tickets or a card or paper having suitable instructions thereon for the milkman. The laterally extending strands 9 provide a substantially straight back for the frame, which, abutting with the supporting member for the device stabilizes the frame.

It is believed, from the foregoing description, when taken in connection with the drawings, the simplicity and advantages of the construction will be apparent without further detailed description.

What I claim is:

In a device for the purpose set forth, a frame formed from a single strand of wire

and designed to be disposed horizontally, said frame having equally spaced reëntrant loops constituting spring clamps for engaging with the necks of milk bottles, the end strands of the frame being bent around themselves and continued in opposite directions angularly with respect to the frame, said end strands being formed with loops designed to receive supporting elements, and a supporting wire between the upper strand 10 and the frame.

In testimony whereof I affix my signature.

JAMES A. R. PHIPPS.

Copies of this patent may be obtained for five cents each, by addressing the "Commissioner of Patents, Washington, D. C."