



INTERNATIONAL APPLICATION PUBLISHED UNDER THE PATENT COOPERATION TREATY (PCT)

<p>(51) International Patent Classification ⁶ : A61F 2/06</p>	<p>A1</p>	<p>(11) International Publication Number: WO 98/19628 (43) International Publication Date: 14 May 1998 (14.05.98)</p>
<p>(21) International Application Number: PCT/US97/18201 (22) International Filing Date: 17 October 1997 (17.10.97) (30) Priority Data: 08/744,002 4 November 1996 (04.11.96) US (71)(72) Applicants and Inventors: VARDI, Gil, M. [US/US]; Apartment 1002-B, 333 E. Ontario, Chicago, IL 60611 (US). DAVIDSON, Charles, J. [US/US]; 1311 Sunview Lane, Winnetka, IL 60093 (US). (74) Agent: YOUNG, Richard, W.; Gardner, Carton & Douglas, Suite 3400, 321 North Clark, Chicago, IL 60610 (US).</p>		<p>(81) Designated States: AL, AM, AT, AU, AZ, BA, BB, BG, BR, BY, CA, CH, CN, CU, CZ, DE, DK, EE, ES, FI, GB, GE, GH, HU, IL, IS, JP, KE, KG, KP, KR, KZ, LC, LK, LR, LS, LT, LU, LV, MD, MG, MK, MN, MW, MX, NO, NZ, PL, PT, RO, RU, SD, SE, SG, SI, SK, SL, TJ, TM, TR, TT, UA, UG, UZ, VN, YU, ZW, ARIPO patent (GH, KE, LS, MW, SD, SZ, UG, ZW), Eurasian patent (AM, AZ, BY, KG, KZ, MD, RU, TJ, TM), European patent (AT, BE, CH, DE, DK, ES, FI, FR, GB, GR, IE, IT, LU, MC, NL, PT, SE), OAPI patent (BF, BJ, CF, CG, CI, CM, GA, GN, ML, MR, NE, SN, TD, TG). Published <i>With international search report.</i></p>

(54) Title: EXTENDIBLE STENT APPARATUS AND METHOD FOR DEPLOYING THE SAME

(57) Abstract

An imageable extending stent apparatus (10) for insertion into a bifurcating vessel having a main vessel (8) and branch vessel (7), is disclosed. The stent apparatus (10) comprises a main stent (12) and a flared stent (15), which may be used individually or in combination with each other. The flared stent (15) may be interlocked with the main stent (12) to provide coverage over the entire region of the bifurcation. The flared stent (15) has a proximal end (30) with the flared portion made of extended loops (18) which fit into the side of the main stent (12).

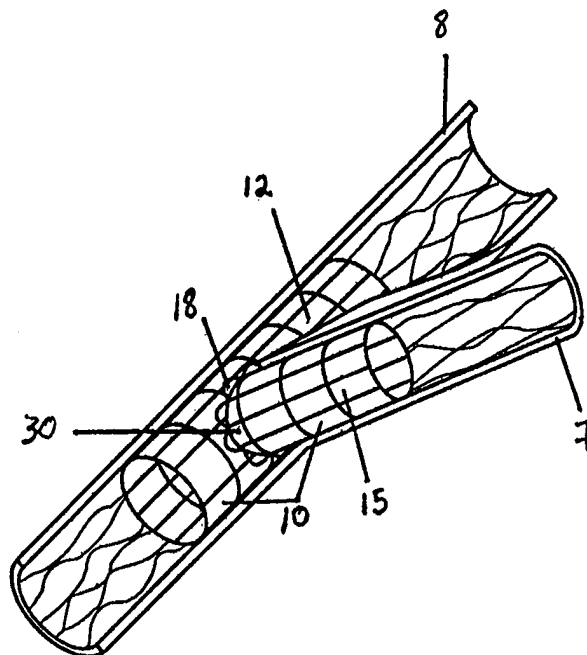

FOR THE PURPOSES OF INFORMATION ONLY

Codes used to identify States party to the PCT on the front pages of pamphlets publishing international applications under the PCT.

AL	Albania	ES	Spain	LS	Lesotho	SI	Slovenia
AM	Armenia	FI	Finland	LT	Lithuania	SK	Slovakia
AT	Austria	FR	France	LU	Luxembourg	SN	Senegal
AU	Australia	GA	Gabon	LV	Latvia	SZ	Swaziland
AZ	Azerbaijan	GB	United Kingdom	MC	Monaco	TD	Chad
BA	Bosnia and Herzegovina	GE	Georgia	MD	Republic of Moldova	TG	Togo
BB	Barbados	GH	Ghana	MG	Madagascar	TJ	Tajikistan
BE	Belgium	GN	Guinea	MK	The former Yugoslav Republic of Macedonia	TM	Turkmenistan
BF	Burkina Faso	GR	Greece			TR	Turkey
BG	Bulgaria	HU	Hungary	ML	Mali	TT	Trinidad and Tobago
BJ	Benin	IE	Ireland	MN	Mongolia	UA	Ukraine
BR	Brazil	IL	Israel	MR	Mauritania	UG	Uganda
BY	Belarus	IS	Iceland	MW	Malawi	US	United States of America
CA	Canada	IT	Italy	MX	Mexico	UZ	Uzbekistan
CF	Central African Republic	JP	Japan	NE	Niger	VN	Viet Nam
CG	Congo	KE	Kenya	NL	Netherlands	YU	Yugoslavia
CH	Switzerland	KG	Kyrgyzstan	NO	Norway	ZW	Zimbabwe
CI	Côte d'Ivoire	KP	Democratic People's Republic of Korea	NZ	New Zealand		
CM	Cameroon			PL	Poland		
CN	China	KR	Republic of Korea	PT	Portugal		
CU	Cuba	KZ	Kazakstan	RO	Romania		
CZ	Czech Republic	LC	Saint Lucia	RU	Russian Federation		
DE	Germany	LI	Liechtenstein	SD	Sudan		
DK	Denmark	LK	Sri Lanka	SE	Sweden		
EE	Estonia	LR	Liberia	SG	Singapore		

5

**EXTENDIBLE STENT APPARATUS
AND METHOD FOR DEPLOYING THE SAME**

Background

A type of endoprosthesis device, commonly referred to as a stent, is placed or implanted within a vein, artery or other tubular body organ for treating occlusions, stenoses, or aneurysms of the vessel. These stent devices are implanted within tubular vessels to reinforce collapsing, partially occluded, weakened, or abnormally dilated segments of the vessel wall. Stents have been used to treat dissections in blood vessel walls caused by balloon angioplasty of the coronary arteries as well as peripheral arteries and to improve angioplasty results by preventing elastic recoil and remodeling of the vessel wall.

15 Stents also have been successfully implanted in the urinary tract, the bile duct, the esophagus and the tracheo-bronchial tree to reinforce those body organs. Two randomized multicenter trials have recently shown a lower restenosis rate in stent treated coronary arteries compared with balloon angioplasty alone (Serruys PW et. al. New England Journal of Medicine 331: 489-495, 1994, Fischman DL et. al. New England Journal of Medicine 331: 496-501, 1994).

20 One of the drawbacks of conventional stents is that they are produced in a straight tubular configuration. The use of such stents to treat disease at or near a branch or bifurcation of a vessel runs the risk of compromising the degree of patency of the primary vessel and/or its branches or bifurcation and also limits the ability to insert a second stent into the side branch if the angioplasty result is suboptimal. This may occur as a result of several mechanisms such as
25 displacing diseased tissue or plaque shifting, vessel spasm, dissection with or without intimal flaps, thrombosis, and embolism.

The risk of branch compromise is increased in two anatomical situations. First the side branch can be compromised when there is a stenosis in the origin of the side branch. Second,

5 when there is an eccentric lesion at the bifurcation site, asymmetric expansion can cause either plaque shifting or dissection at the side branch origin. There are reports of attempting to solve this problem by inserting a balloon into the side branch through the stent struts; however, this technique carries the risk of balloon entrapment and other major complications (Nakamura, S. et al., *Catheterization and Cardiovascular Diagnosis* 34: 353-361 (1995)). Moreover, adequate
10 dilatation of the side branch is limited by elastic recoil of the origin of the side branch. In addition, the stent may pose a limitation to blood flow and may limit access to the side branch. The term "stent jail" is often used to describe this concept. In this regard, the tubular slotted hinged design of the Palmaz-Schatz intracoronary stent, in particular, is felt to be unfavorable for lesions with a large side branch and it is believed to pose a higher risk of side branch vessel
15 entrapment where the stent prevents or limits access to the side branch. *Id.*

One common procedure for implanting the endoprosthesis or stent is to first open the region of the vessel with a balloon catheter and then place the stent in a position that bridges the treated portion of the vessel in order to prevent elastic recoil and restenosis of that segment. The angioplasty of the bifurcation lesion has traditionally been performed using the kissing balloon
20 technique where two guidewires and two balloons are inserted, one into the main branch and the other into the side branch. Stent placement in this situation will require the removal of the guidewire from the side branch and reinsertion of the guidewire via the stent struts and insertion of a balloon through the struts of the stent. The removal of the guidewire poses the risk of occlusion of the side branch during the deployment of the stent in the main branch.

25 Prior art patents refer to the construction and design of both the stent as well as the apparatus for positioning the stent within the vessel. One representative patent to Chaudhury, U.S. Pat. No. 4,140,126, discloses a technique for positioning an elongated cylindrical stent at a region of an aneurysm to avoid catastrophic failure of the blood vessel wall. The '126 patent

5 discloses a cylinder that expands to its implanted configuration after insertion with the aid of a catheter. Dotter, U.S. Pat. No. 4,503,569, discloses a spring stent which expands to an implanted configuration with a change in temperature. The spring stent is implanted in a coiled orientation and is then heated to cause the spring to expand. Palmaz, U.S. Pat. No. 4,733,665, discloses a number of stent configurations for implantation with the aid of a catheter. The catheter includes
10 a mechanism for mounting and retaining the vascular prosthesis or stent, preferably on an inflatable portion of the catheter. The stents are implanted while imaged on a monitor. Once the stent is properly positioned, the catheter is expanded and the stent separated from the catheter body. The catheter can then be withdrawn from the subject, leaving the stent in place within the blood vessel. Palmaz, U.S. Pat. No. 4,739,762, discloses an expandable intraluminal graft.
15 Schjeldahl et. al., U.S. Pat. No. 4,413,989, discloses a variety of balloon catheter constructions. Maginot, U.S. Pat. No. 5,456,712 and Maginot, U.S. Pat. No. 5,304,220 disclose graft and stent assembly and method of implantation where a stent is used to reinforce a graft surgically inserted into a blood vessel in order to bypass an occlusion. However, none of these patents relate to the treatment of bifurcation lesions, or disclose a bifurcating stent apparatus and method for
20 deploying the same.

Taheri , U.S. Pat. No. 4,872,874, Piplani et. al., U.S. Pat. No. 5,489,295, and Marin et al., U.S. Pat. No. 5,507,769, disclose bifurcating graft material which may be implanted with stents. However, there is no mention of bifurcation of the stent, and the stent is used only to anchor the graft into the vessel wall. It does not reinforce the vessel wall, nor does it prevent restenosis
25 after angioplasty.

MacGregor, U.S. Pat. No. 4,994,071, discloses a hinged bifurcating stent. In the 071' patent, in contrast to the present invention, there is a main stent with two additional stents attached at one end, creating a single unit with a bifurcation. The two additional stents are

5 permanently attached and cannot be removed from the main stent. Thus, this invention may not be used in non-bifurcation vessels. In addition, studies with hinge-containing stents have shown that there is a high incidence of restenosis (tissue growth) at the hinge point that may cause narrowing or total occlusion of the vessel and thus compromise blood flow. Furthermore, this design has a relatively large size which makes insertion into the vessel difficult. Also, by having
10 the two additional stents connected to the main stent, tracking into a wide-angle side branch may be difficult and may carry the risk of dissection of the vessel wall. Furthermore, once the device of the '071 patent is implanted, it is impossible to exchange the side branch stent should the need for a different stent size arise.

In general, when treating a bifurcation lesion using commercially available stents, great
15 care should be taken to cover the origin of the branch because if left uncovered, this area is prone to restenosis. In order to cover the branch origin, conventional stents must either protrude into the lumen of the main artery or vessel from the branch (which may causes thrombosis [clotting of blood], again compromising blood flow), or they must be placed entirely within the branch, and will generally not cover the origin of the bifurcation. Another frequent complication experienced
20 with the stenting of bifurcations include narrowing or occlusion of the origin of a side branch spanned by a stent placed in the main branch. Lastly, placement of a stent into a main vessel where the stent partially or completely extends across the opening of a branch may make future access into such branch vessels difficult if not impossible.

In addition, conventional stent technology is inadequate as a means of treating ostial
25 lesions. Ostial lesions are lesions at the origin of a vessel. For example, ostial lesions may form in renal arteries, which are side branches extending from the aorta. Ostial lesions are prone to restenosis due to elastic recoil of the main vessel, such as the aorta. Therefore, the stent cover

5 must include the thickness of the wall of the main vessel. This is extremely difficult to accomplish without protrusion of the stent into the main vessel.

Lastly, conventional stents are difficult to visualize during and after deployment. While some prior art balloon catheters are "marked" at the proximal and distal ends of the balloon with imageable patches, no FDA-approved stents are currently available which are themselves
10 imageable through currently known imaging procedures used when inserting the stents into a vessel.

Accordingly, there is a need for an improved stent apparatus and method for deploying the same which 1) may be used to effectively treat bifurcation lesions which reduces the risk of restenosis or occlusion of the side branch and which completely covers bifurcation lesions with
15 the stent apparatus, 2) may be used to treat lesions in one branch of a bifurcation while preserving access to the other branch for future treatment, 3) may be used to treat ostial lesions, 4) allows for differential sizing of the stents in a bifurcated stent apparatus even after the main stent is implanted, and which 5) may be readily visualized by current or future visualization techniques.

20 SUMMARY OF THE INVENTION

The present invention concerns a novel extendable stent apparatuses and method for deploying the same. More particularly, the invention concerns a stent apparatus comprising an extendable stent which is suitable for treating bifurcation lesions, and which may also be used to treat lesions at the origin of a blood vessel or other organ. As used herein, the term "vessel"
25 means any tubular tissue, and is not limited to vessels of the vascular system. Devices constructed in accordance with the invention include, singularly or in combination, a flared stent comprising a compressible flared portion at its proximal end, which flared portion may comprise hooks, compressible mesh or any other means of creating such a flared portion at the proximal

5 end of the stent, and a main stent comprising at least one substantially circular opening located between its proximal and distal ends. For ease of visualization, both the flared stent and the main stent may be comprised of materials which are imageable, or the stents of the invention may be "marked" at the ends with an imageable substance and the main stent may also be marked at any opening. At least one flared stent may be extended through at least one opening of the main stent
10 into at least one branch vessel for treating bifurcated or branched lesions, or the stents of the invention may be inserted individually for the treatment of ostial lesions, or lesions near bifurcations requiring a stent in either the main or the branch vessel with unobstructed access to the unstented vessel in the bifurcation. The methods of the invention comprises a two-step process used to deploy both the main and the flared stent in a bifurcated vessel, or to deploy the
15 main stent only within a bifurcated vessel.

The stent apparatus of the invention may be constructed from any non-immunoreactive material that allows the apparatus to be expanded from an initial shape to a shape which conforms to the shape of the vessel or vessels into which the apparatus is inserted, including but not limited to any of the materials disclosed in the prior art stents, which are incorporated herein
20 by reference. It is hypothesized that the stent apparatuses of the invention may further be constructed of a substance which is observable by imaging methods including but not limited to magnetic resonance, ultrasound, radio-opaque or contrast-dye, or may be marked at certain points including but not limited to the ends and around any opening or flared portion in a stent of the invention, with a material which is discernable by imaging methods as described above.

25 A stent constructed in accordance with the invention is suitable for implantation into any vessel in the body, including but not limited to vessels in the cardiac system, the peripheral vascular system, the carotid and intracranial vessels, the venous system, the renal system, the

5 biliary system, the gastrointestinal system, the tracheobronchial system, the biliary system and the genitourinary system.

The stents of the invention are deployed utilizing a set of guidewires and catheters, which are then withdrawn from the subject following deployment of the stents. The stents of the invention may be self-expanding to conform to the shape of the subject vessel, or they may be
10 expanded utilizing balloon catheters, or by any method currently known or developed in the future which is effective for expanding the stents of the invention. The flared stent of the invention is constructed such that the flared portion is confined along the wall of the flared stent by a sheath running parallel to the longitudinal axis of the flared stent until deployment, during which the sheath is removed and the flared portion is expanded into a configuration extending
15 radially, at least in part, from the longitudinal axis of the flared stent.

Thus, it is an object of the present invention to provide a double-stent apparatus which makes it possible to completely cover the origin of a bifurcation lesion with a stent apparatus.

Another object of the invention is to provide a single-stent apparatus and method for
20 deploying the same which may be used to treat only one branch of a bifurcation lesion but which will facilitate future treatment of the corresponding branch.

Yet another object of the invention is to provide a single-stent apparatus which is effective in treating ostial lesions.

A further object of the invention is to provide a method for insertion of the extendable double-stent apparatus into both the main and branch vessels of a bifurcation lesion.

25 Additionally, it is an object of the invention to provide a stent apparatus which is imageable during and after insertion.

These objects and other object advantages and features of the invention will become better understood from the detailed description of the invention and the accompanying drawings.

5 BRIEF DESCRIPTION OF THE DRAWINGS

FIG.1 is a schematic depiction of the double-stent apparatus of the present invention in which both the main stent and the flared stent are fully dilated.

FIG.2 is a schematic depiction of the main stent of the apparatus of the invention as deployed, without placement of the flared stent.

10 FIG.3 is a schematic depiction of the flared stent of the apparatus as deployed, without the main stent.

FIG. 4 is a schematic depiction of the main stent of the apparatus deployed within a subject vessel.

FIG. 5 is a schematic depiction of the double-stent bifurcating stent apparatus, where the main
15 stent is deployed and showing the placement of the flared stent apparatus prior to full deployment of the flared stent.

FIG.6 is a schematic depiction of the method of the invention. Figure 6a depicts initial placement of the main stent of the bifurcating stent apparatus into the vessel, along with the insertion of guidewire and stabilizing catheter for placement of the flared stent into the branch
20 vessel of the subject.

FIG. 6b is a schematic depiction of the step of inflating the main stent of the invention.

FIG. 6c is a schematic depiction of the deployment of the flared stent over the side branch guidewire, through an opening in the main stent and into the branch vessel of the subject.

FIG. 6d is a schematic depiction of the removal of the protective sheath of the flared stent,
25 allowing for full expansion of the flared portion prior to placement and deployment.

FIG. 6e is a schematic depiction of the fully extended flared stent positioned into the branch by the catheter, but prior to full deployment.

5 FIG. 6f is a schematic depiction of the fully dilated main stent and the fully positioned flared stent, where the flared stent is being dilated by inflation of the balloon

FIG. 6g is a schematic depiction of the fully dilated bifurcating double stent of the invention, positioned into the bifurcation in a subject vessel.

The rectilinear matrices shown in the drawings are intended to show the shapes of the
10 surfaces only, and do not illustrate the actual surface patterns or appearances of the stent apparatuses of the invention.

DESCRIPTION OF THE PREFERRED EMBODIMENTS

The bifurcating double-stent apparatus **10** of the present invention comprises a generally
15 cylindrical main stent **12** and a generally cylindrical flared stent **15**, which are shown as fully dilated in a subject main vessel **8** and a subject branch vessel **7**, as illustrated in FIG. 1.

The main stent **12** contains at least one generally circular opening **16** located between the proximal end **26** and the distal end **28** of the main stent **12** (FIG. 2), which opening is positioned over the opening **48** of a branch vessel in a vessel bifurcation **50**, as shown in FIG. 2. The ends
20 of the stent **12** and the opening are imaged during imaging procedures by placing markers **56** around the edges of the opening **16** in the main stent **12** and at the proximal end **26** and distal end **28** of the main stent, as illustrated in FIG. 4.

The flared stent apparatus **15** of the present invention comprises a generally cylindrical flared stent comprising a proximal end **30** and a distal end **32**, as shown in FIG3. The proximal
25 end **30** comprises a flared portion, illustrated here as extended loops **18**, which flared portion, when dilated, is positioned within the lumen **58** of the main vessel **8** (FIG. 3). The ends of the flared stent **15** and the flared portion **18** are imaged during imaging procedures by placing

5 markers **56** around the flared portion **18** and at the proximal end **30** and distal end **32** of the flared stent, as illustrated in FIG. 5.

As shown in the embodiment of the invention illustrated in FIG. 4, a guidewire **20** is inserted into the vessel **8** prior to insertion of the main stent **12**, and is used to guide the main stent **12** into position within the vessel **8**. Prior to insertion and dilation, the main stent **12** is
10 disposed around the distal end of a catheter **48** which may include an inflatable balloon **24**. The main stent/catheter apparatus is then threaded onto the main guidewire **20** and into the vessel **8**. The main stent **12** is dilated by inflation of the balloon **24** until it expands the walls of the vessel **8**, and is thus affixed into place.

As shown in the embodiment of the invention illustrated in FIG. 5, prior to insertion of
15 the flared stent **15**, a guidewire **36** and a stabilizing catheter **44** are inserted through the opening **16** in the main stent **12**, and into a branch vessel. The stabilizing catheter **44** is used to place the opening in the main stent **12** over the opening **16** in the bifurcation. The guidewire **36** is used to guide the flared stent **15** into position within a vessel. During insertion and prior to dilation, the flared stent **15** is disposed around the distal end of a branch catheter **54** which may include an
20 inflatable balloon **25**, and the flared portion **18** of the flared stent **15** is held in a compressed position by a protective sheath **34**.

In the bifurcating double-stent apparatus **10** of the invention, once the main stent **12** is dilated and the stabilizing catheter **44** is removed, the flared stent **15** is inserted over the branch guidewire **36** and through the opening **16** of the main stent **12** substantially as shown in FIG. 5,
25 and affixed in place by the expansion of the flared portion **18** positioned at the proximal end **30** of the flared stent, as shown in FIGS. 1 and 5. The angle at which the flared stent **15** is affixed depends upon the vessel structure into which the bifurcating stent apparatus **10** is inserted (FIG. 1).

5 The inventive two-stage method for implanting the novel bifurcating double-stent apparatus **10** begins with insertion of the main guidewire **20** into the subject main vessel **8** and across the bifurcation **50**. Once the main guidewire **20** is in position in the main vessel **8**, the main stent **12** is mounted around a catheter **48** (which may also comprise a balloon **24**), and the catheter **48** and stent **12** are inserted into the main vessel **8**. The stent **12** is positioned so that the opening **16** is directly over the bifurcation point **50** in the subject vessel (FIG. 6a). In order to aid such positioning, a side branch guidewire **36** and a stabilizing catheter **44** (as depicted in FIGS. 5 and 6) are also inserted through the opening **16** of the main stent **12** and into the branch vessel **7** (FIG. 6a).

 In an alternative embodiment of the method of the invention, the main stent **12**, the catheters **44** and **48** and the side branch guidewire **36** may be assembled in advance of insertion (with the stabilizing catheter **44** and the side branch guidewire positioned through the opening **16** of the main stent) into the subject, and then inserted into the bifurcation point **50** in the main vessel **8** simultaneously, after which the side branch guidewire **36** and the stabilizing catheter **44** are threaded into the branch vessel **7** in order to properly align the opening **16** in the main stent **12** (FIG. 6a).

 To affix the main stent **12** in the desired position within the vessel **8**, the stent **12** may be dilated by inflating the balloon **24** until the main stent **12** is in contact with the walls of the vessel **8** (FIG. 6b). Once the main stent **12** is dilated, the catheters **44** and **48** are withdrawn, leaving the fully positioned main stent **12** and the main guidewire **20** in the main subject vessel, and the side branch guidewire **36** in the subject branch vessel (FIG. 6c).

 In the second stage of the method of deploying the bifurcating double-stent of the invention, the flared stent catheter **54**, containing the compressed flared stent **15** in a protective sheath **34** and which may further contain a balloon **25** disposed around the flared stent catheter

5 54 and inside the compressed flared stent 15, is inserted into the subject branch vessel 7 around the side branch guidewire 36 as shown in FIG. 6c. The compressed flared stent 15 is initially positioned so that the compressed proximal end 30 of the flared stent extends into the lumen 42 of the main stent 12 to facilitate full expansion of the flared portion 18 after withdrawal of the protective sheath 34, prior to the final positioning of the flared stent 15 into the branch of the bifurcation (FIG. 6c). The distal end 32 of the flared stent is initially positioned within the branch vessel 7 (FIG. 6c). After the proximal end 30 of the compressed flared stent is properly placed within the lumen 42 of the main stent, the protective sheath 34 is withdrawn from the vessel 8, and the flared portion 18 of the flared stent 15 is decompressed to extend radially, at least in part, to the longitudinal axis of the flared stent 15, as shown in FIG. 6d. After the flared portion 18 of the flared stent 15 is in its flared configuration (as shown in FIG. 6d), the flared stent 15 is advanced into the side branch 7 at its proximal end 30 until at least a portion of flared portion 18 of the flared sheath 15 contacts at least a portion of an edge of the opening 16 of the main stent 12, as shown in FIG. 6e. In this example, a balloon 25 is inflated in order to dilate the flared stent 15 to bring the walls of the flared stent 15 into contact with the walls of the branch vessel 7, as shown in FIG. 6f. All remaining catheters and guidewires are then withdrawn from the subject, leaving the fully deployed bifurcating double-stent apparatus of the invention 10, comprising the main stent 12 with at least one opening 16, and the flared stent 15 positioned through the opening 16 into the branch vessel 7, as shown in FIG. 6g.

When treating ostial lesions, the flared stent 15 alone is used, and is positioned utilizing catheters and guidewires as described above, except that a stabilizing catheter is not used, and the flared portion 18 of the flared stent is positioned at the ostium of a vessel, instead of into a side branch through the an opening 16 in a main branch. After the flared stent 15 is positioned near the ostium of a subject vessel, the protective sheath 34 is retracted in order to allow the flared

5 portion to fully expanded and the flared stent **15** is further advanced with the proximal end of the catheter until the unfolded hooks **18** are in contact with the walls of the subject vessel.

All the stents of the invention may be deployed using the methods of the invention without resort to a balloon catheter. For example, a self-expanding compressed stent contained within a protective sheath could be self-dilated by retraction of a protective sheath. Other
10 methods of dilation of the stents of the invention may exist, or may become available in the future, and such methods are contemplated as being within the scope of this invention. While this example used self-unfolding loops to demonstrate one means of creating a flared portion, any other means of creating a flare, such as but not limited to creating a roll in the stent material which is then compressed, is contemplated as within the scope of this invention.

15 It is the intent that the invention include all modifications and alterations from the disclosed embodiments that fall within the scope of the claims of the invention.

5 We claim:

1. An extending double-stent apparatus for placement in a bifurcating vessel comprising a first generally cylindrical stent having sides extending between first and second opposing ends and at least one opening being defined in a side; and a second generally cylindrical stent adapted to extend through one of said side openings of said first stent, said first and second stents each
10 being constructed from a material which allows said stents to be expanded to conform to the shape of the subject vessel.
2. The stent apparatus of Claim 1 wherein said second cylindrical stent additionally comprises a proximal end and an opposing distal end, wherein the proximal end additionally comprises a flared portion, which flared portion is in contact with the edges of said first stent side
15 opening.
3. The stent apparatus of Claim 1 wherein the stent apparatus is comprised of a biologically acceptable material.
4. The stent apparatus of Claim 1 wherein the stents comprise a self-expanding material.
5. The stent apparatus of Claim 1 wherein the stents comprise a balloon-expandable
20 material.
6. The stent apparatus of Claim 1 wherein at least a portion of the stents are imageable during and after insertion.
7. A generally cylindrical stent apparatus comprising a proximal end and a distal end, wherein the proximal end further comprises a flared portion for anchoring said stent apparatus
25 into place within a vessel.
8. The stent apparatus of Claim 7 wherein the flared portion is expandable from a compressed position to a configuration extending radially, at least in part, to the longitudinal axis of the stent apparatus.

- 5 9. The stent apparatus of Claim 7 wherein the stent apparatus is comprised of a biologically acceptable material.
10. The stent apparatus of Claim 7 wherein the stent comprises a self-expanding material.
11. The stent apparatus of Claim 7 wherein the stents comprise a balloon-expandable material.
- 10 12. The stent apparatus of Claim 7 wherein at least a portion of the stent is imageable during and after insertion.
13. A generally cylindrical stent apparatus having sides extending between first and second opposing ends and at least one opening being defined in a stent side.
14. The stent apparatus of Claim 13 wherein the stent apparatus is comprised of a
- 15 biologically acceptable material.
15. The stent apparatus of Claim 13 wherein the stent comprises a self-expanding material.
16. The stent apparatus of Claim 13 wherein at least a portion of the stents are imageable during and after insertion.
17. A method for deploying a stent apparatus into a bifurcated vessel comprising the steps of
- 20 routing a first guidewire into the main vessel of a subject bifurcating vessel and extending the guidewire beyond the bifurcation point;
- inserting a first generally cylindrical stent apparatus comprising at least one side opening into an area of bifurcation of the main vessel;
- aligning a side opening of the first stent apparatus with the bifurcation point of the
- 25 bifurcated vessel by inserting a second guidewire and a stabilizing catheter into the first stent apparatus and into a subject branch vessel by passing the second guidewire and the stabilizing catheter through a side opening of the first stent apparatus and into the subject branch vessel; and

5 expanding the first cylindrical stent apparatus into contact with the walls of the main vessel.

18. The method of Claim 17 further comprising

inserting along the second guidewire and into the stabilizing catheter of the branch vessel a second generally cylindrical stent apparatus, comprising a distal end and an opposed proximal end and further comprising a flared portion at the proximal end, positioned so that the flared portion is within a lumen of a subject branch vessel and contacts at least part of the edge of a side opening of the first stent apparatus;

withdrawing the stabilizing catheter from the subject vessel; and

expanding the second cylindrical stent apparatus at least into contact with the walls of the subject branch vessel.

19. The method of Claim 17 wherein the step of expanding the first cylindrical stent apparatus is performed by balloon catheterization.

20. The method of Claim 18 wherein the steps of expanding the first and second cylindrical stent apparatuses is performed by balloon catheterization.

21. A method for deploying a flared stent apparatus into the ostium of a vessel comprising:

inserting a guidewire through the ostium of a vessel and into the vessel,

inserting around the guidewire a generally cylindrical flared stent apparatus, the flared stent apparatus comprising a distal end and an opposed proximal end and further comprising a flared portion at the proximal end;

positioning the flared portion so that the flared portion is within the ostium of the vessel and contacts at least part of the ostium of said vessel;

5 dilating the flared stent apparatus at least into contact with the walls of the subject vessel;
and
removing the guidewire from the subject.

22. The method of Claim 21 further comprising the step of dilating the flared stent apparatus by balloon catheterization.

Fig. 1

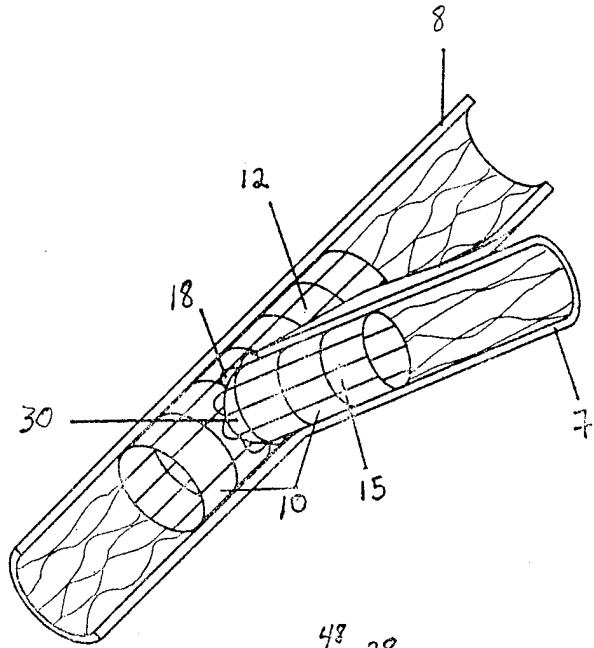

Fig. 2

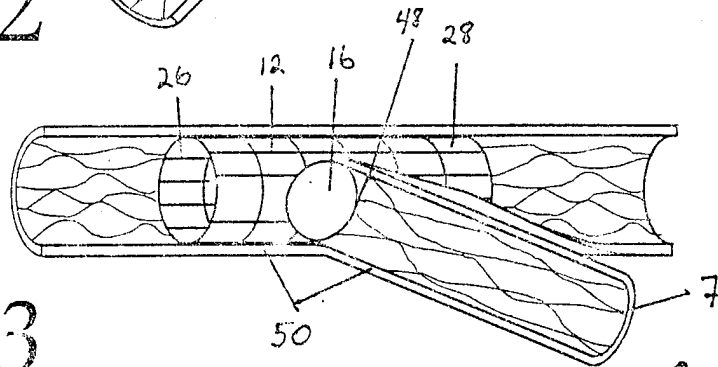

Fig. 3

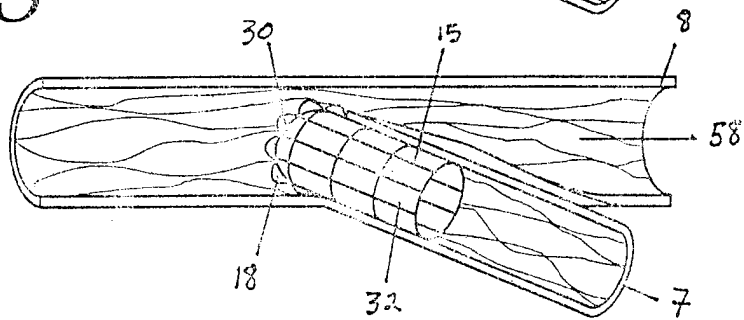
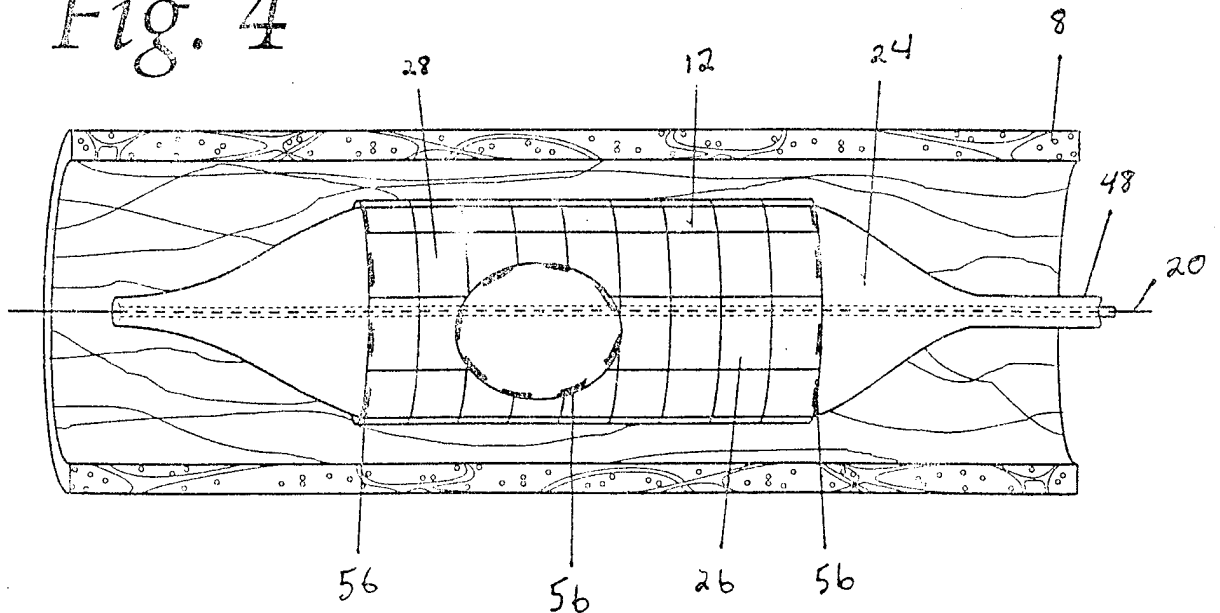

Fig. 4



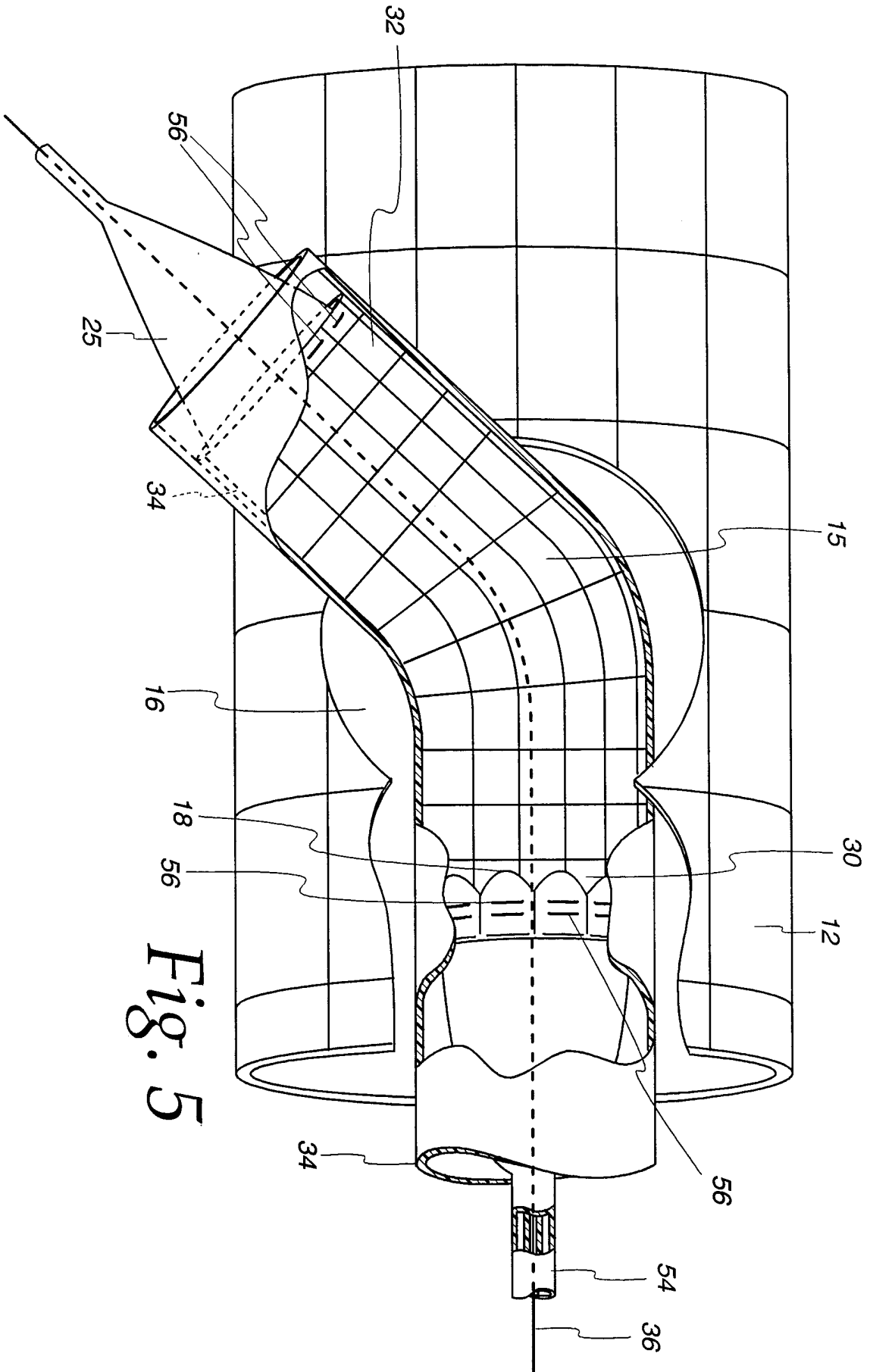

Fig. 5

Fig. 6a

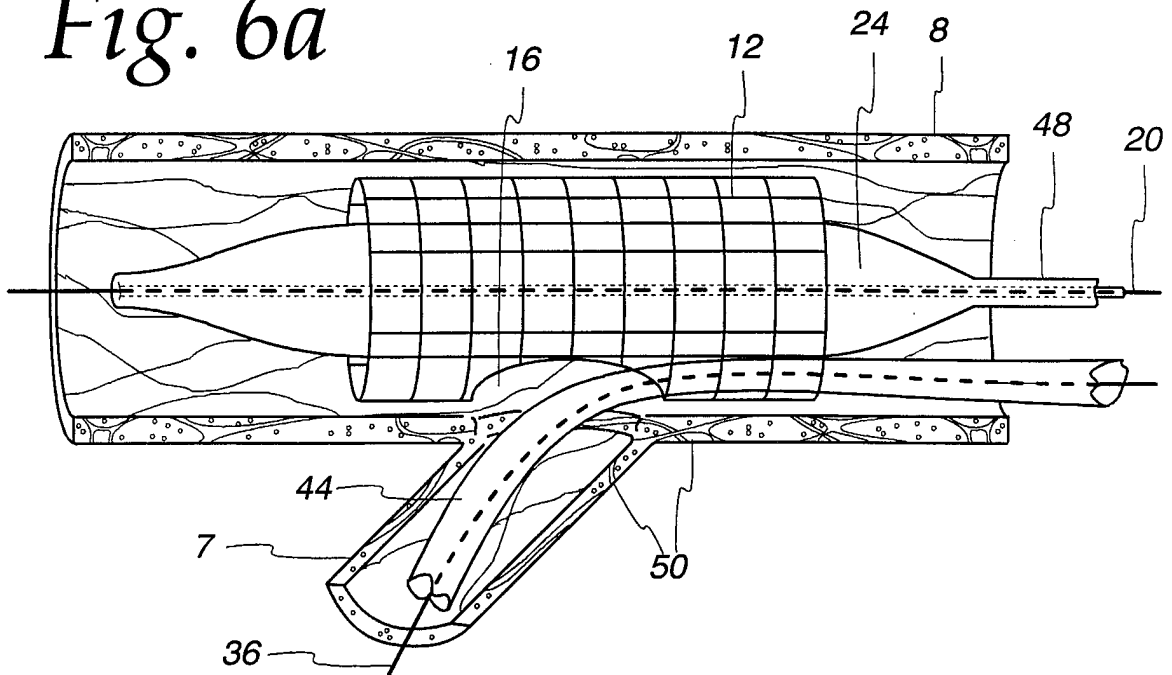

Fig. 6b

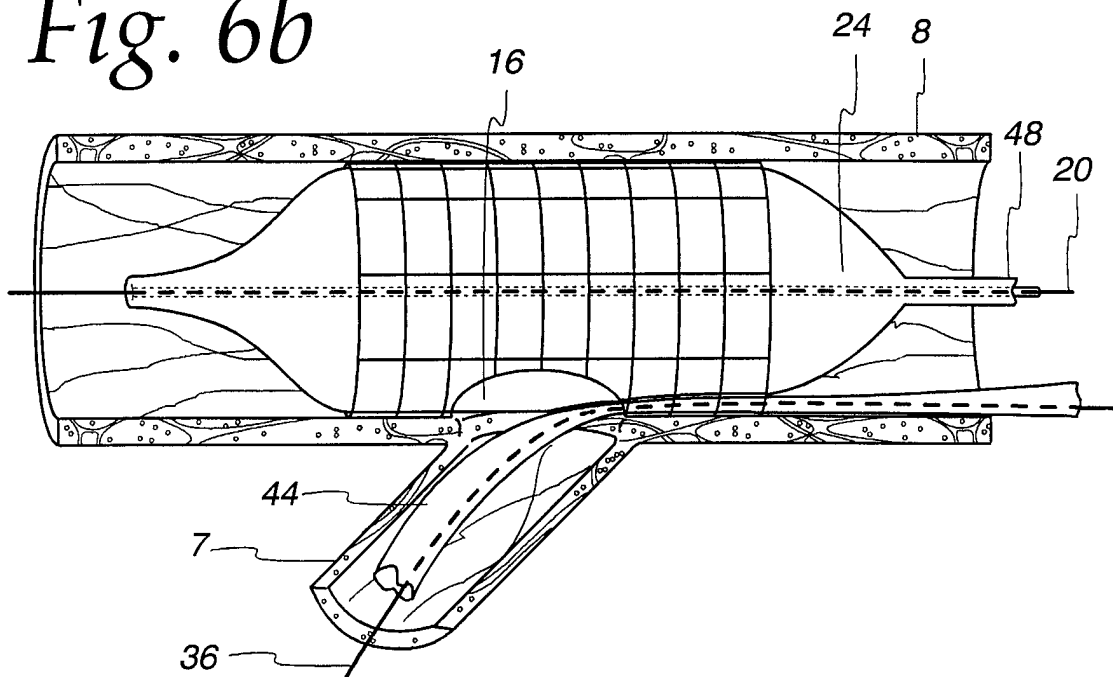

Fig. 6c

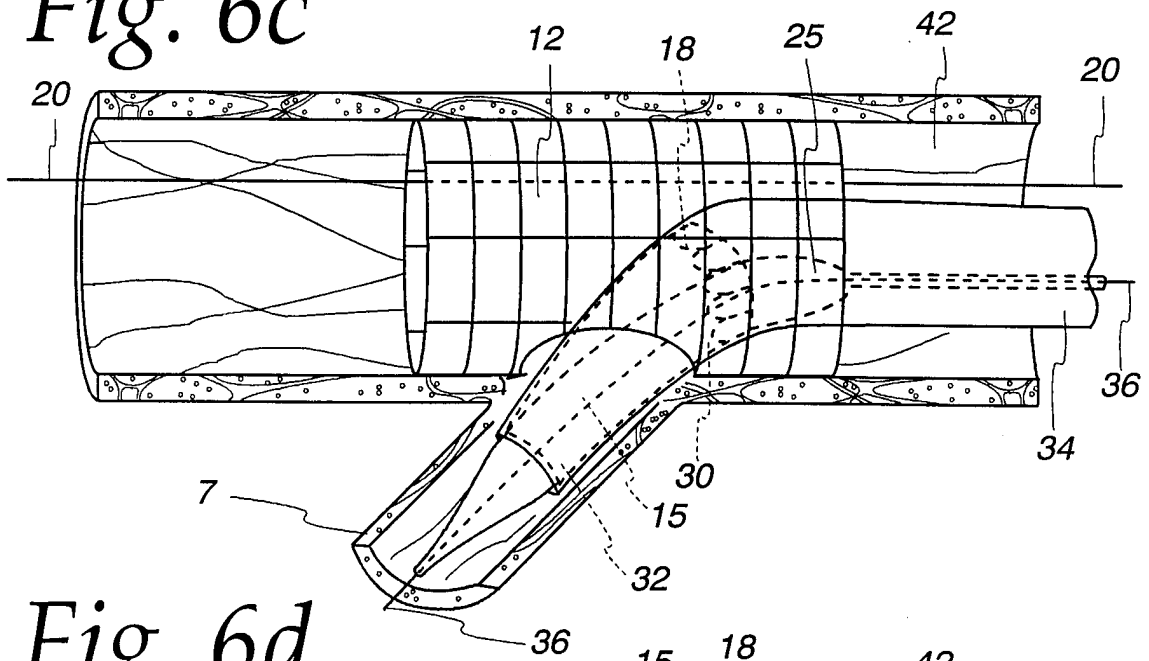

Fig. 6d

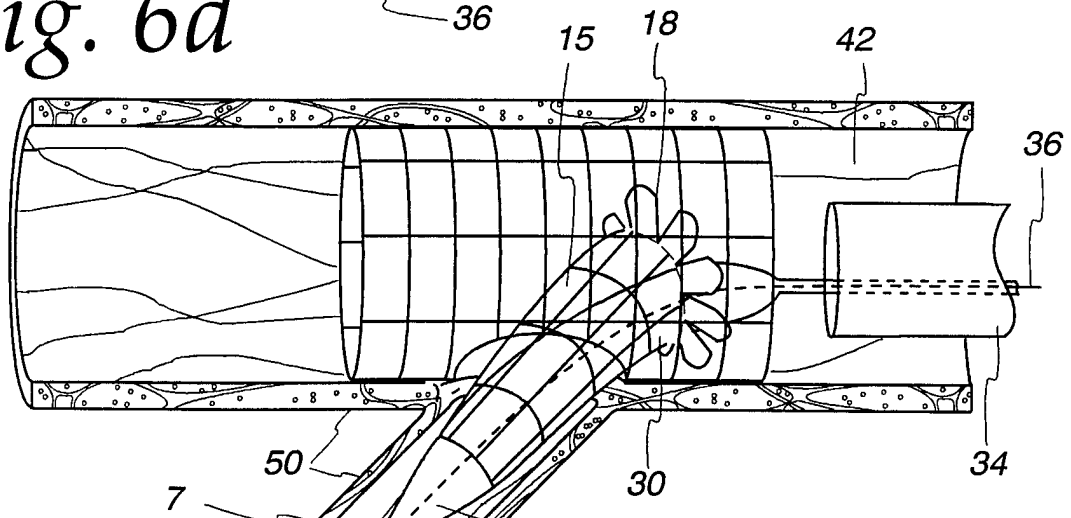

Fig. 6e

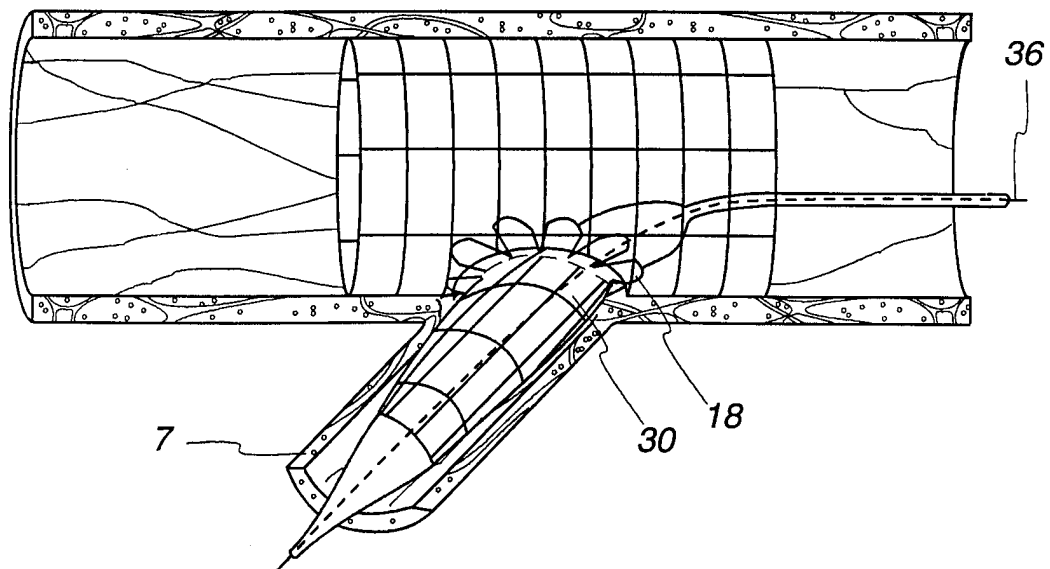

Fig. 6f

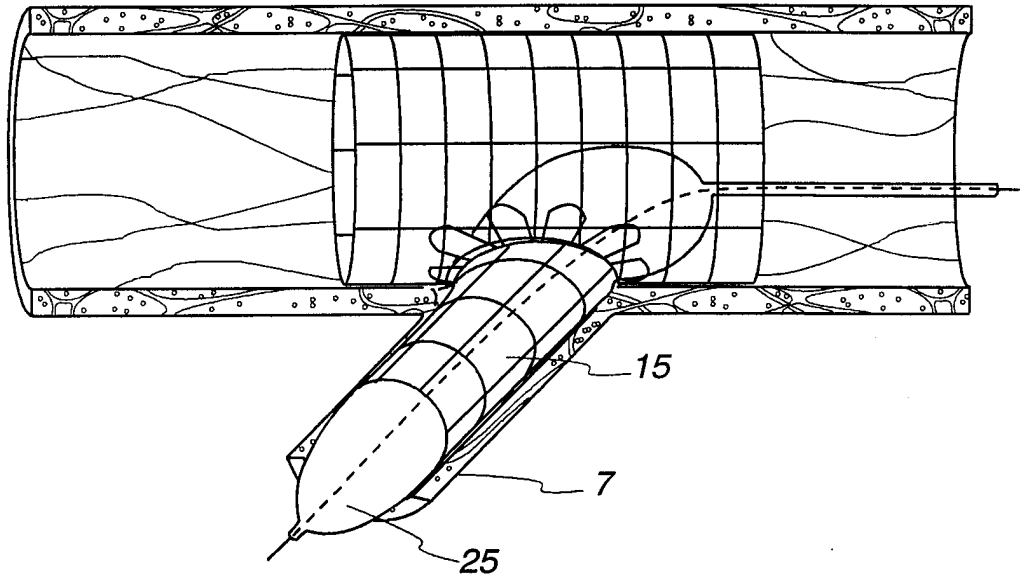
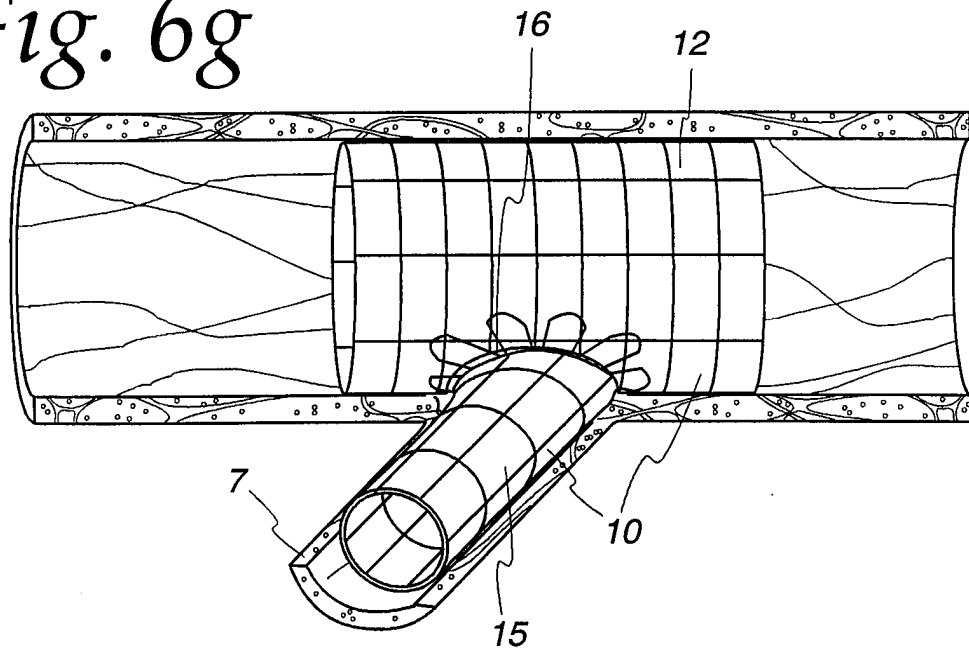

Fig. 6g



INTERNATIONAL SEARCH REPORT

International application No.
PCT/US97/18201

A. CLASSIFICATION OF SUBJECT MATTER

IPC(6) :A61F 2/06
US CL :623/1

According to International Patent Classification (IPC) or to both national classification and IPC

B. FIELDS SEARCHED

Minimum documentation searched (classification system followed by classification symbols)

U.S. : 606/191, 194, 195; 623/1, 11

Documentation searched other than minimum documentation to the extent that such documents are included in the fields searched

Electronic data base consulted during the international search (name of data base and, where practicable, search terms used)

C. DOCUMENTS CONSIDERED TO BE RELEVANT

Category*	Citation of document, with indication, where appropriate, of the relevant passages	Relevant to claim No.
X	US 5,443,497 A (VENBRUX) 22 August 1995, tire document.	1-7, 9, 11, 13-16.
X	US 4,957,508 A (KANEKO et al) 18 September 1990, entire document.	7-12
Y, P	US 5,617,878 A (TAHERI) 08 April 1997, entire document.	17-22

Further documents are listed in the continuation of Box C. See patent family annex.

* Special categories of cited documents:	"T" later document published after the international filing date or priority date and not in conflict with the application but cited to understand the principle or theory underlying the invention
"A" document defining the general state of the art which is not considered to be of particular relevance	"X" document of particular relevance; the claimed invention cannot be considered novel or cannot be considered to involve an inventive step when the document is taken alone
"E" earlier document published on or after the international filing date	"Y" document of particular relevance; the claimed invention cannot be considered to involve an inventive step when the document is combined with one or more other such documents, such combination being obvious to a person skilled in the art
"L" document which may throw doubts on priority claim(s) or which is cited to establish the publication date of another citation or other special reason (as specified)	"&" document member of the same patent family
"O" document referring to an oral disclosure, use, exhibition or other means	
"P" document published prior to the international filing date but later than the priority date claimed	

Date of the actual completion of the international search

28 NOVEMBER 1997

Date of mailing of the international search report

23 DEC 1997

Name and mailing address of the ISA/US
Commissioner of Patents and Trademarks
Box PCT
Washington, D.C. 20231

Authorized officer

PAUL PREBILIC

Facsimile No. (703) 305-3230

Telephone No. (703) 308-2905