



US00RE43016E

(19) **United States**
(12) **Reissued Patent**
Saitoh

(10) **Patent Number:** **US RE43,016 E**
(45) **Date of Reissued Patent:** **Dec. 13, 2011**

(54) **VARIABLE FOCAL LENGTH LENS,
PHOTOGRAPHING LENS UNIT, CAMERA,
AND PORTABLE INFORMATION TERMINAL
DEVICE**

6,545,819	B1	4/2003	Nanba et al.	359/689
6,744,564	B2 *	6/2004	Mihara et al.	359/680
6,822,808	B2 *	11/2004	Nanba et al.	359/689
6,862,143	B2 *	3/2005	Hoshi et al.	359/689
7,212,242	B2	5/2007	Watanabe et al.	348/357

(75) Inventor: **Takao Saitoh**, Tokyo (JP)
(73) Assignee: **Ricoh Company, Ltd.**, Tokyo (JP)
(21) Appl. No.: **12/141,181**
(22) Filed: **Jun. 18, 2008**

FOREIGN PATENT DOCUMENTS

JP	2002-365545	12/2002
JP	2003-35868	2/2003
JP	2003-107352	4/2003
JP	2003-114386	4/2003
JP	2003-131134	5/2003

* cited by examiner

Related U.S. Patent Documents

Reissue of:
(64) Patent No.: **7,002,756**
Issued: **Feb. 21, 2006**
Appl. No.: **10/882,363**
Filed: **Jul. 2, 2004**

Primary Examiner — Mohammed Hasan
(74) *Attorney, Agent, or Firm* — Oblon, Spivak,
McClelland, Maier & Neustadt, L.L.P.

(30) **Foreign Application Priority Data**

Jul. 3, 2003 (JP) 2003-191519

(51) **Int. Cl.**
G02B 15/14 (2006.01)
(52) **U.S. Cl.** **359/689; 359/680**
(58) **Field of Classification Search** **359/680-683,**
359/689
See application file for complete search history.

(57) **ABSTRACT**
A negative first group optical system, a positive second group optical system, and a positive third group optical system are sequentially arranged from the object side. A stop moving integrally with the second group optical system is provided on the object side of the second group optical system. The focal length is changed by changing distances between the group optical systems, and the third group optical system is moved on an optical axis. The first group optical system includes a negative meniscus lens, a negative meniscus lens, and a positive lens. The second group optical system includes a cemented lens of a positive lens and a negative lens, a positive lens, and a positive lens. The third group optical system includes one positive lens not including an aspherical surface.

(56) **References Cited**

U.S. PATENT DOCUMENTS

5,619,301	A	4/1997	Suzuki et al.	396/114
6,308,011	B1	10/2001	Wachi et al.	396/72

14 Claims, 13 Drawing Sheets

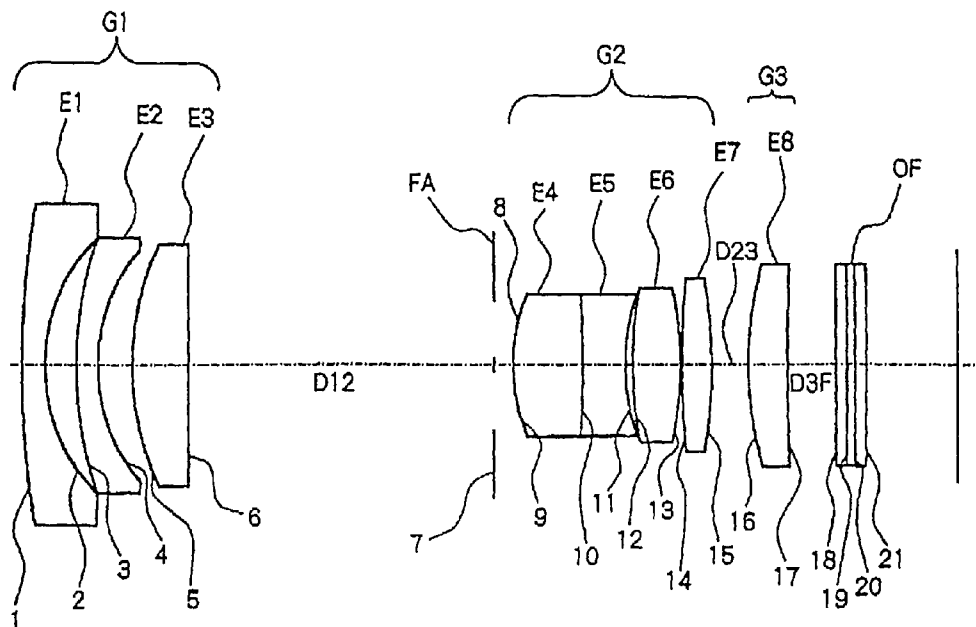

FIG. 1

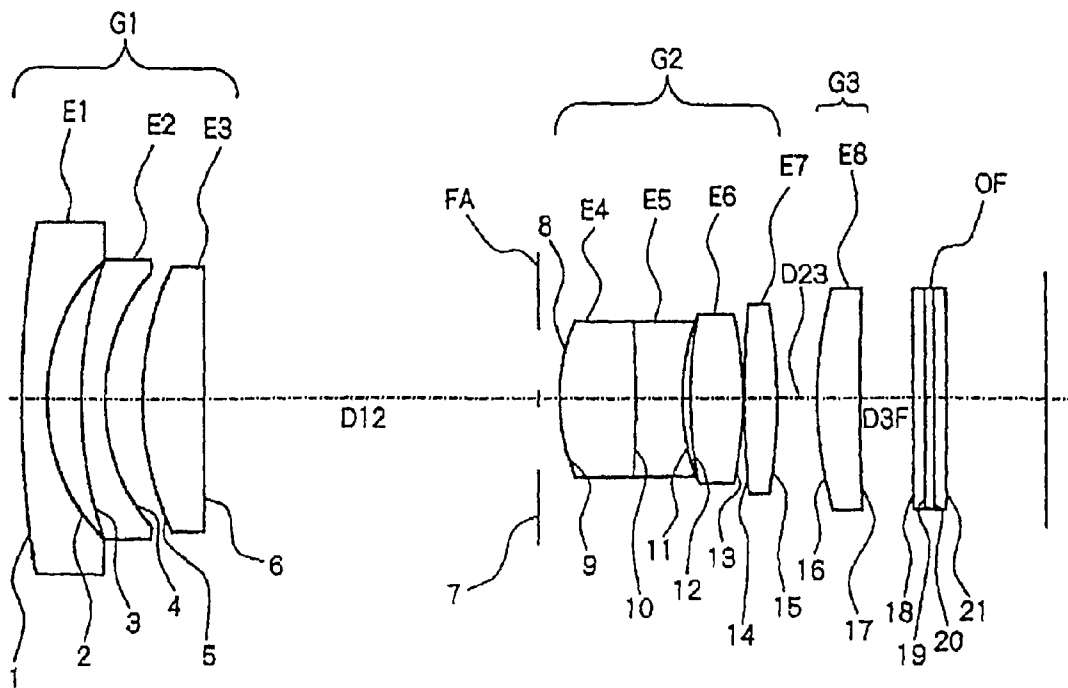

FIG.2

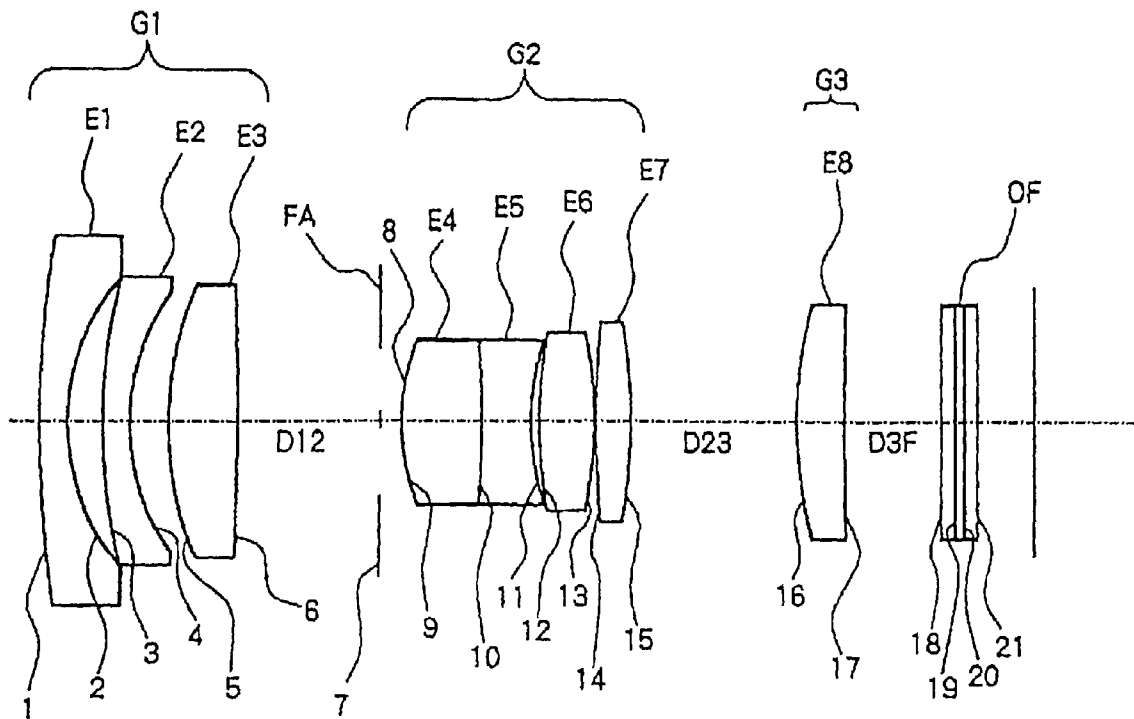

FIG.3

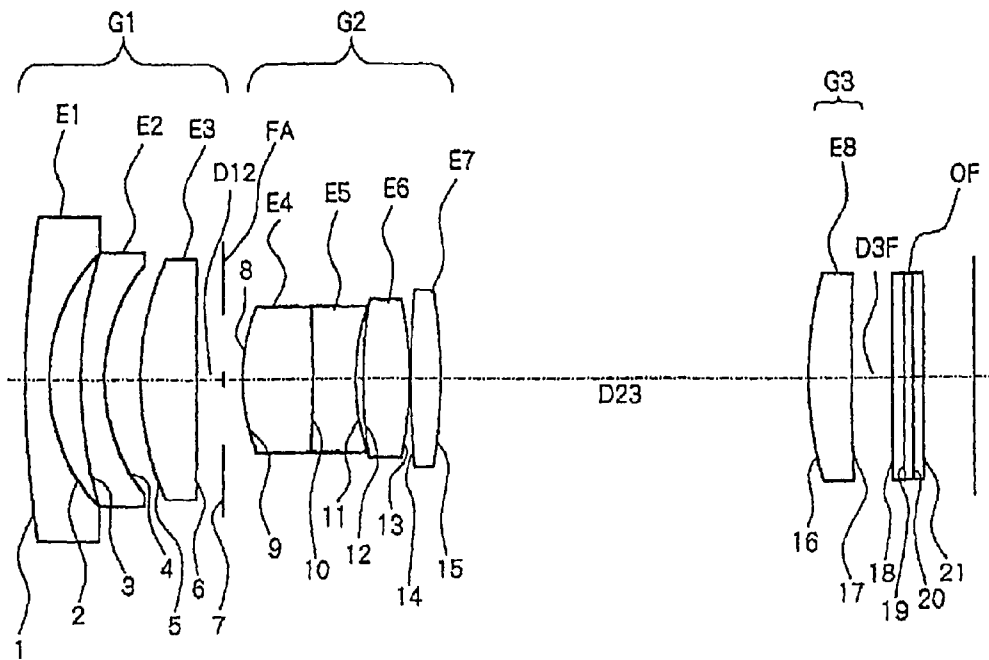

FIG. 4

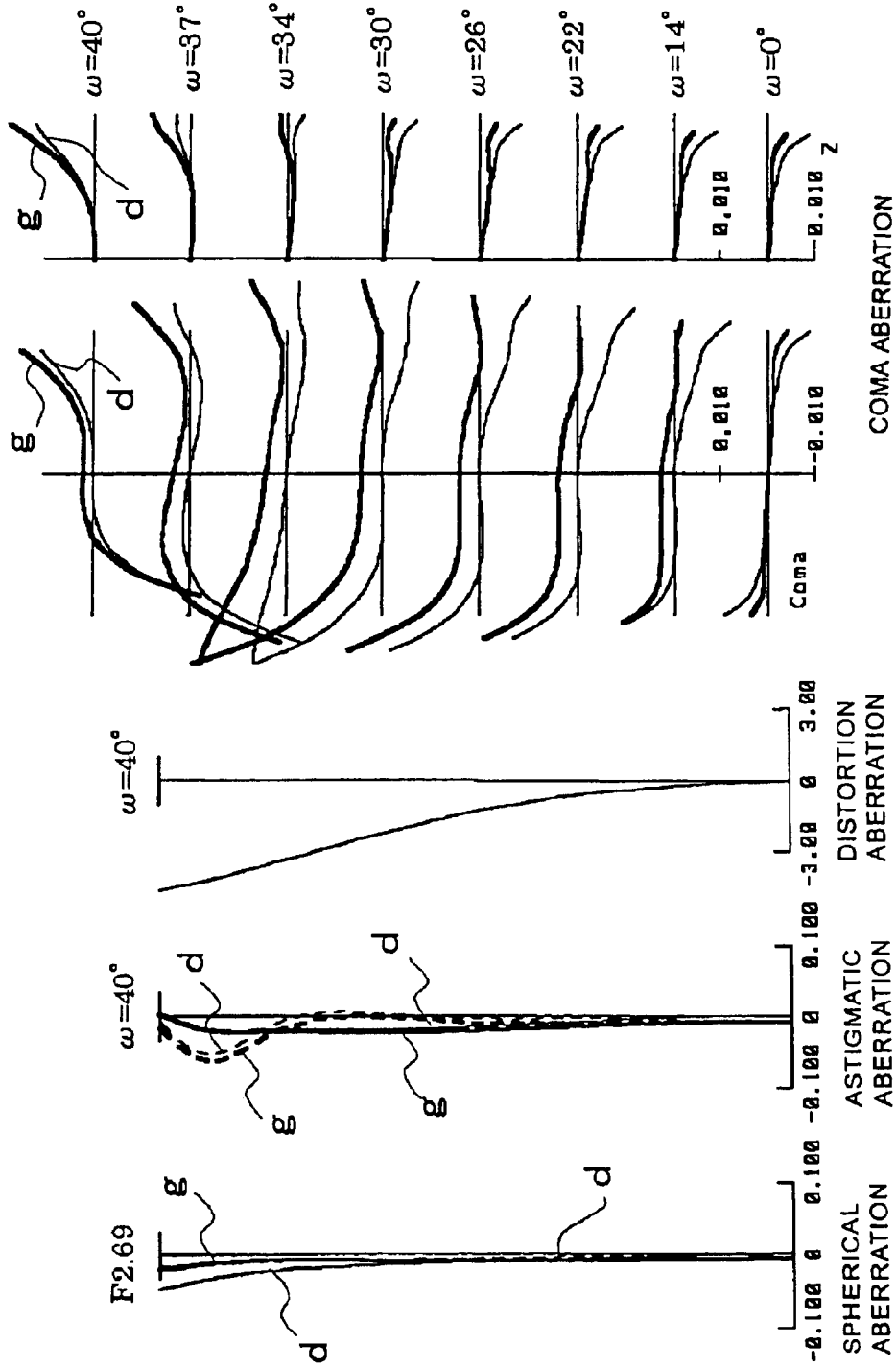

FIG.5

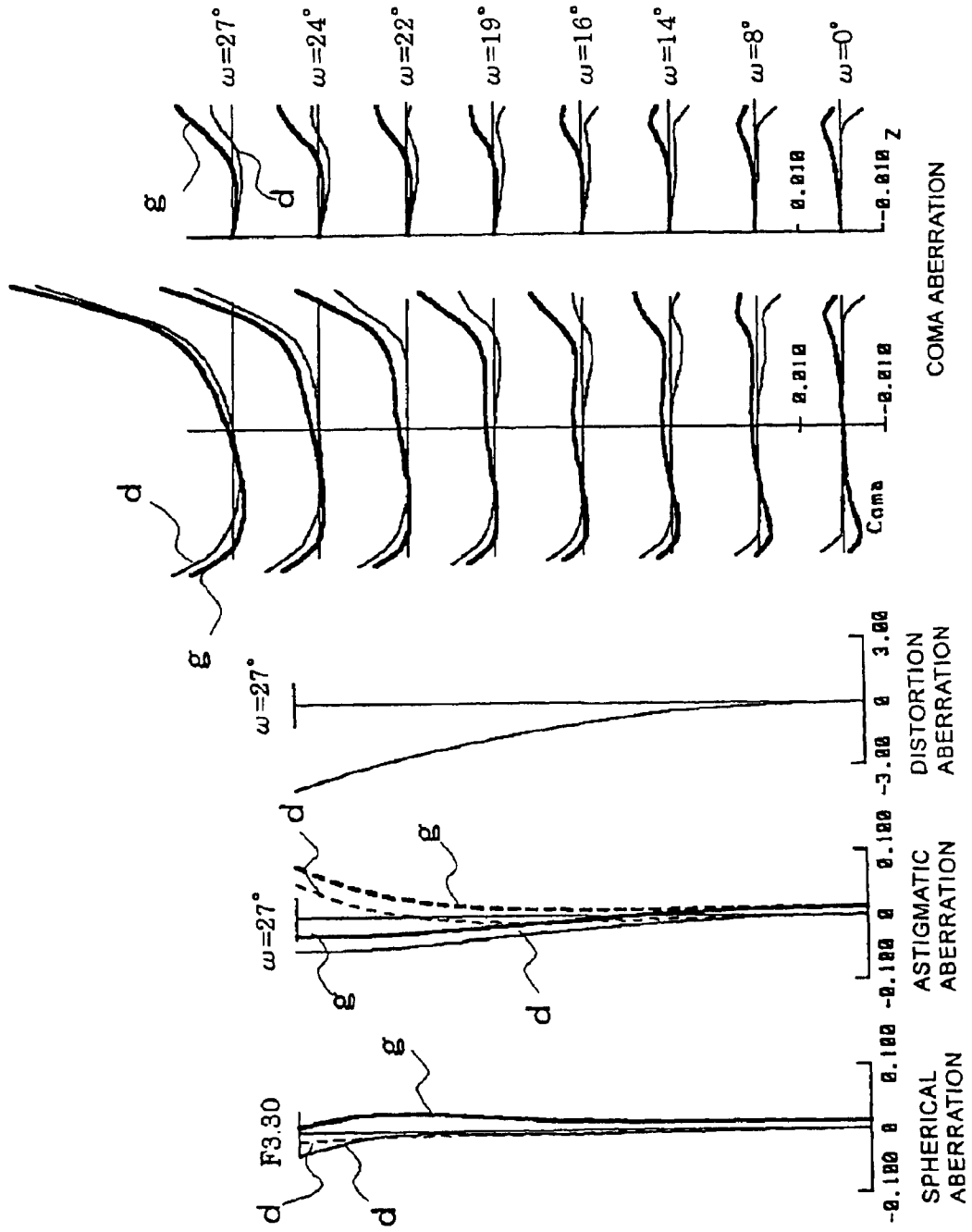

FIG.6

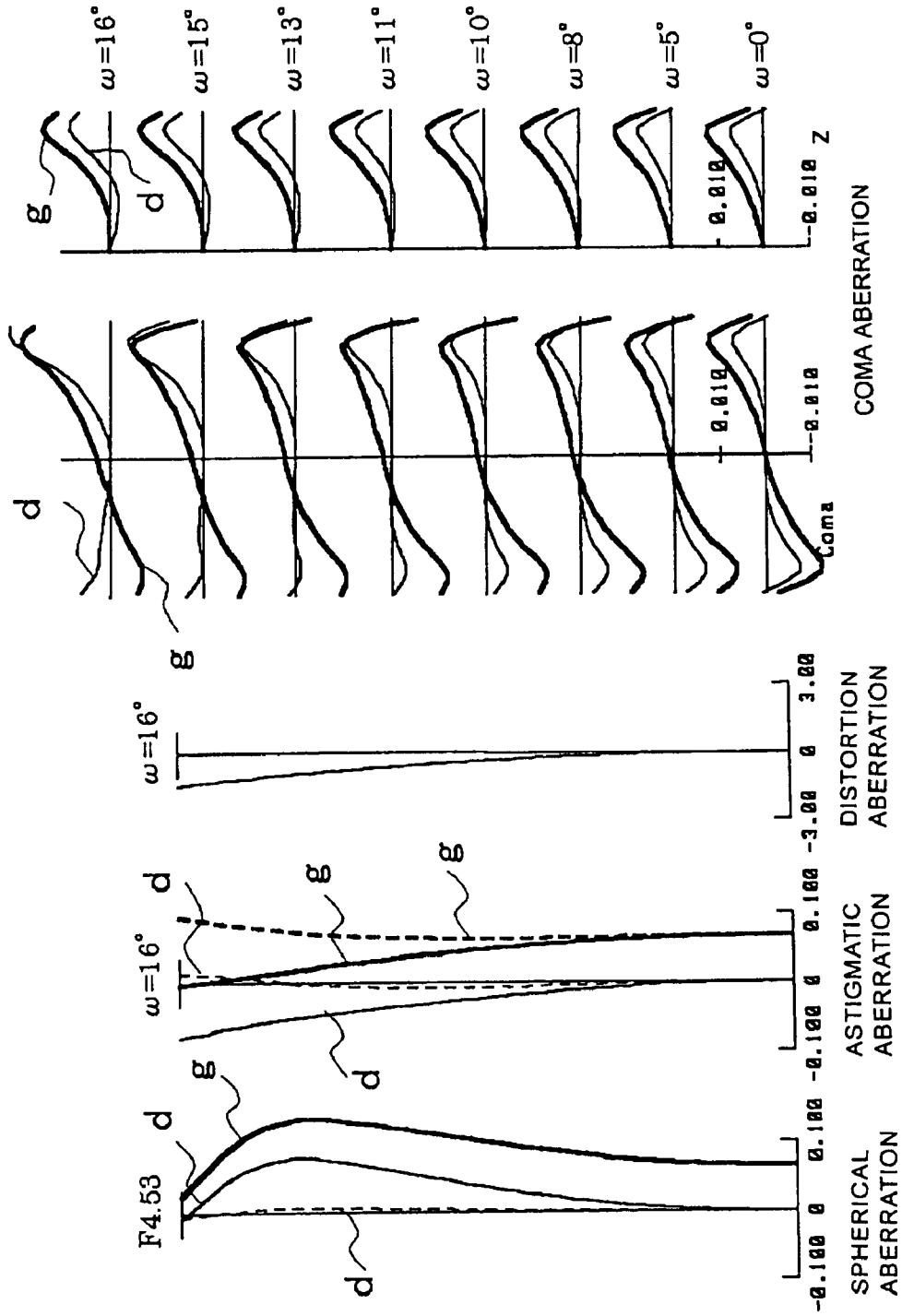

FIG. 7

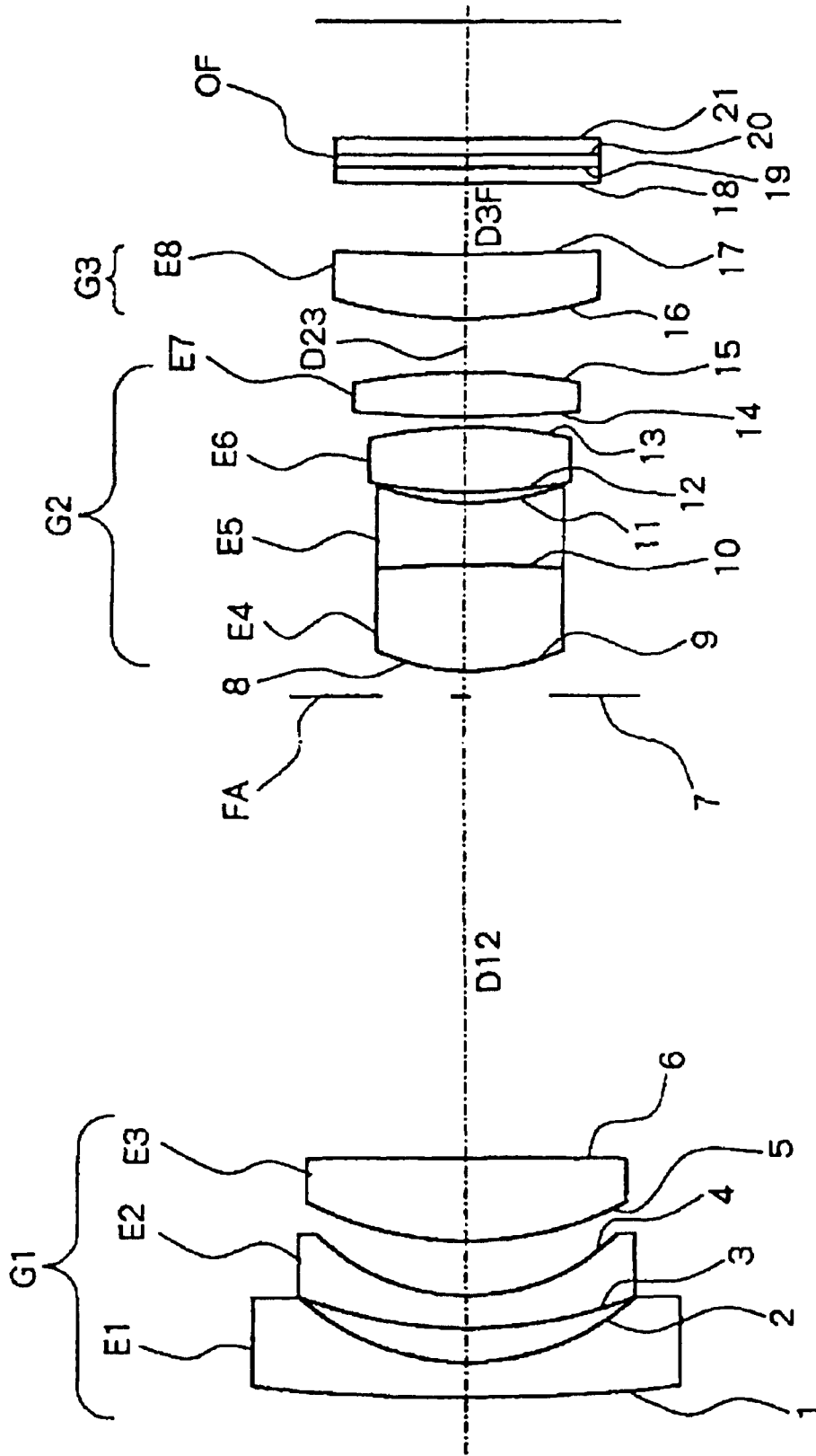

FIG.8

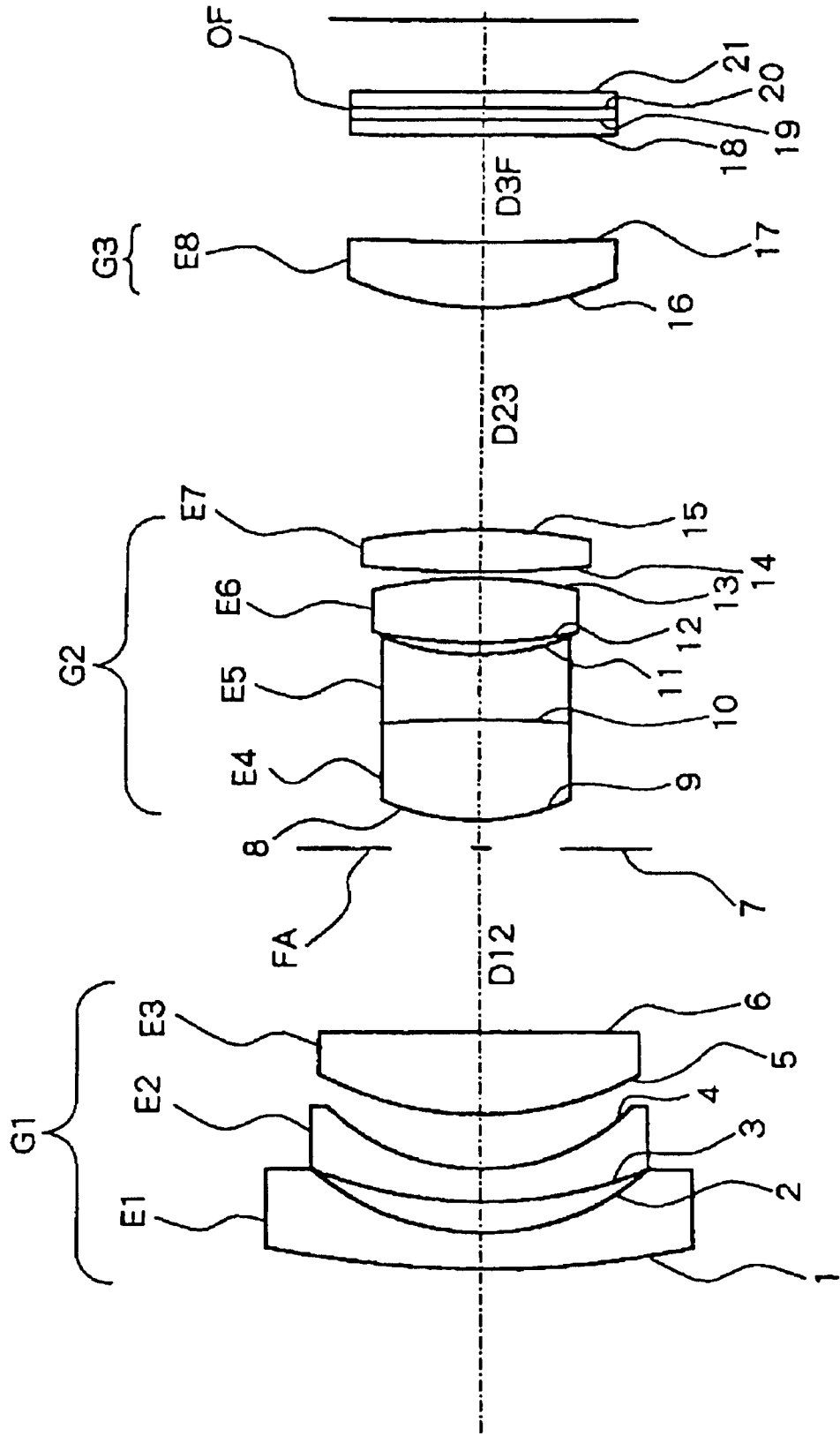

FIG.9

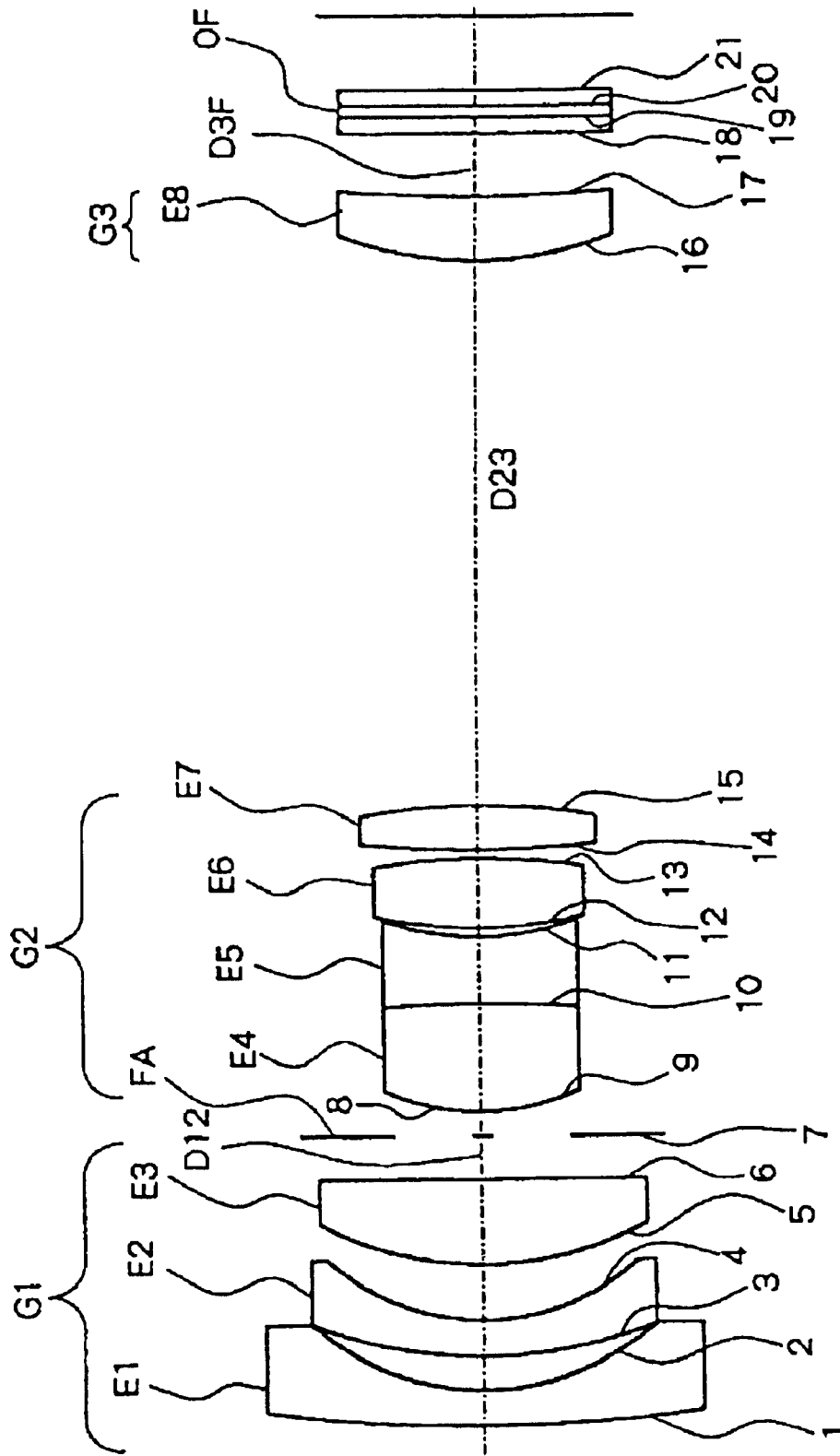

FIG.11

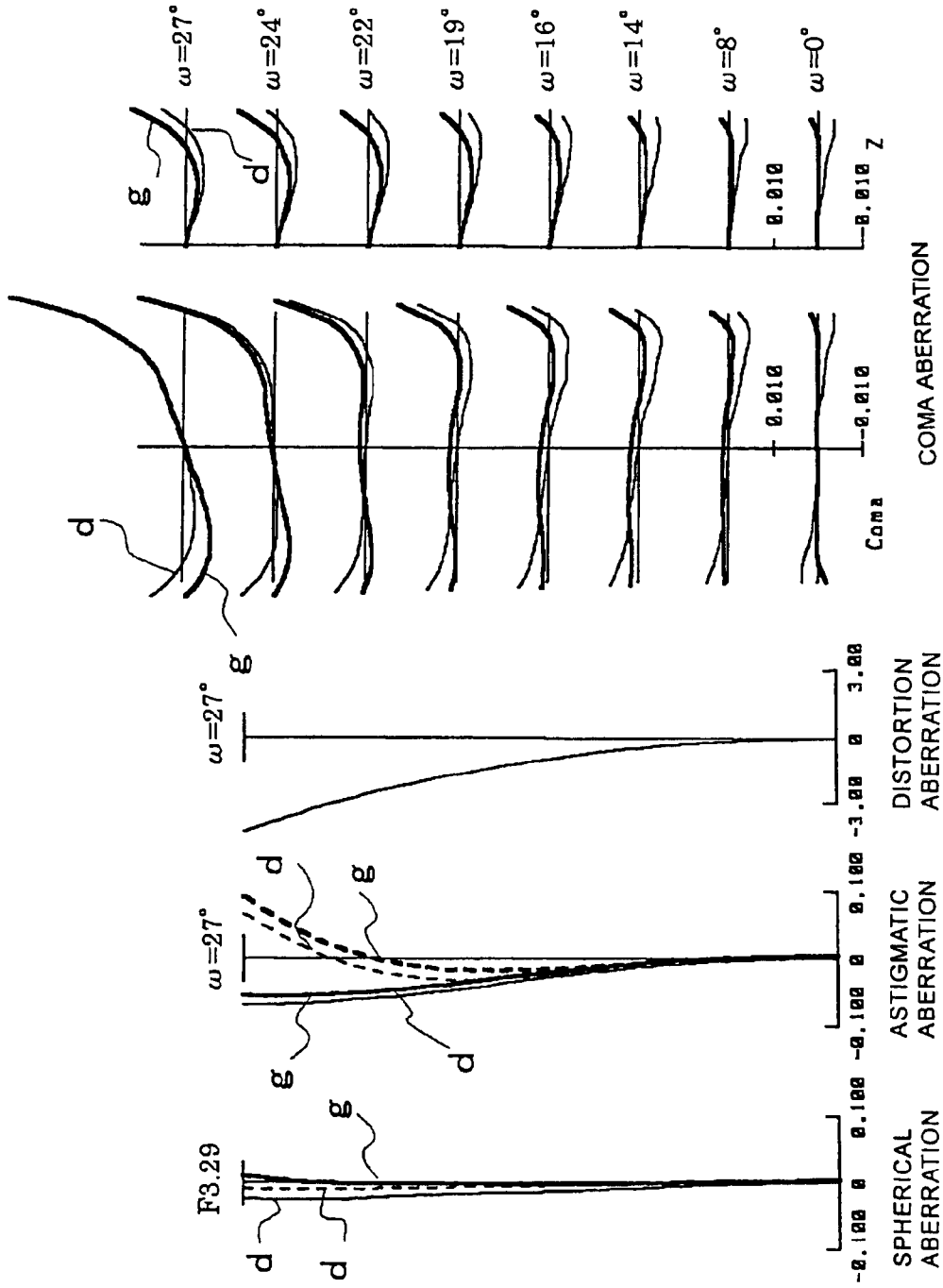

FIG.12

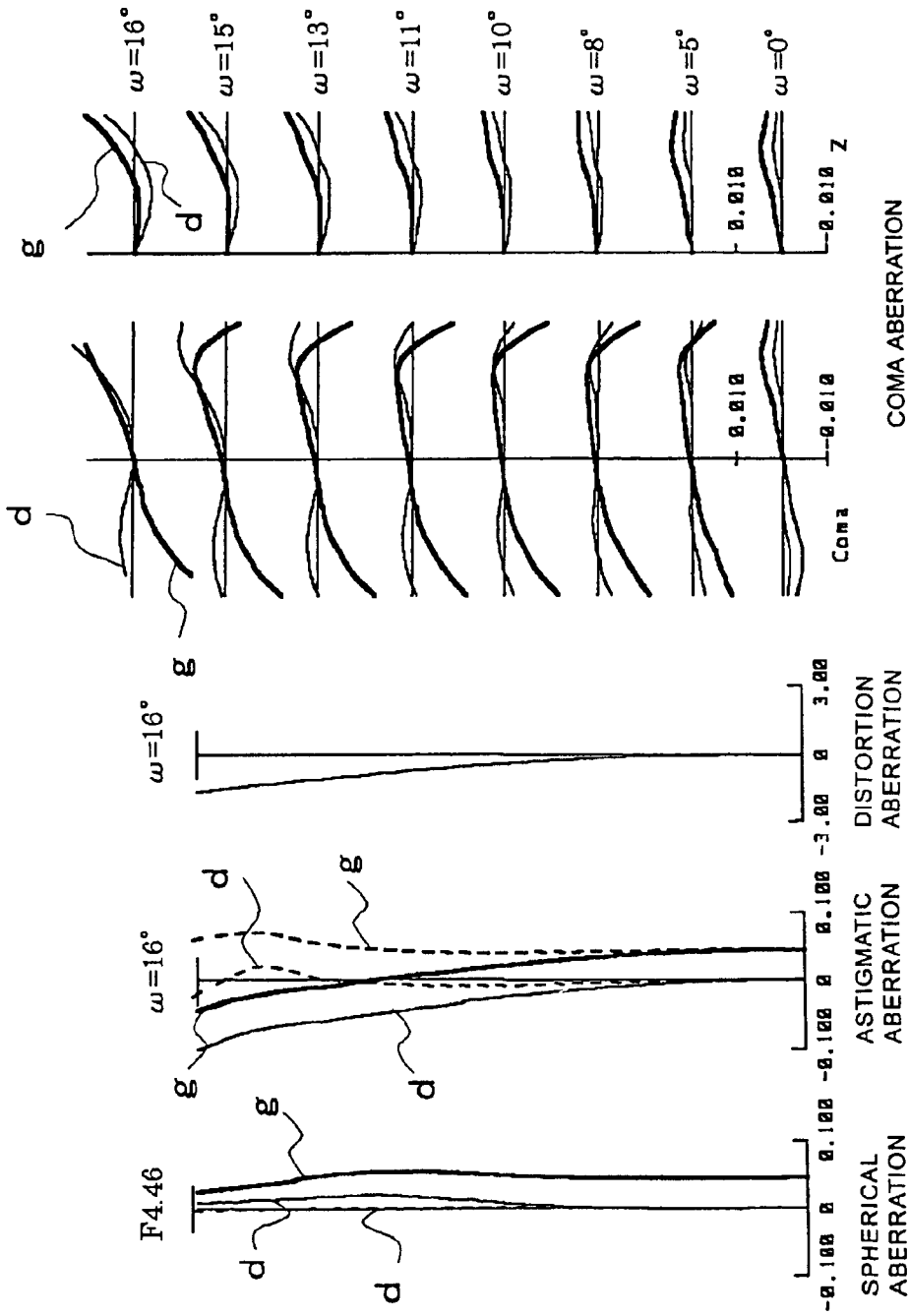
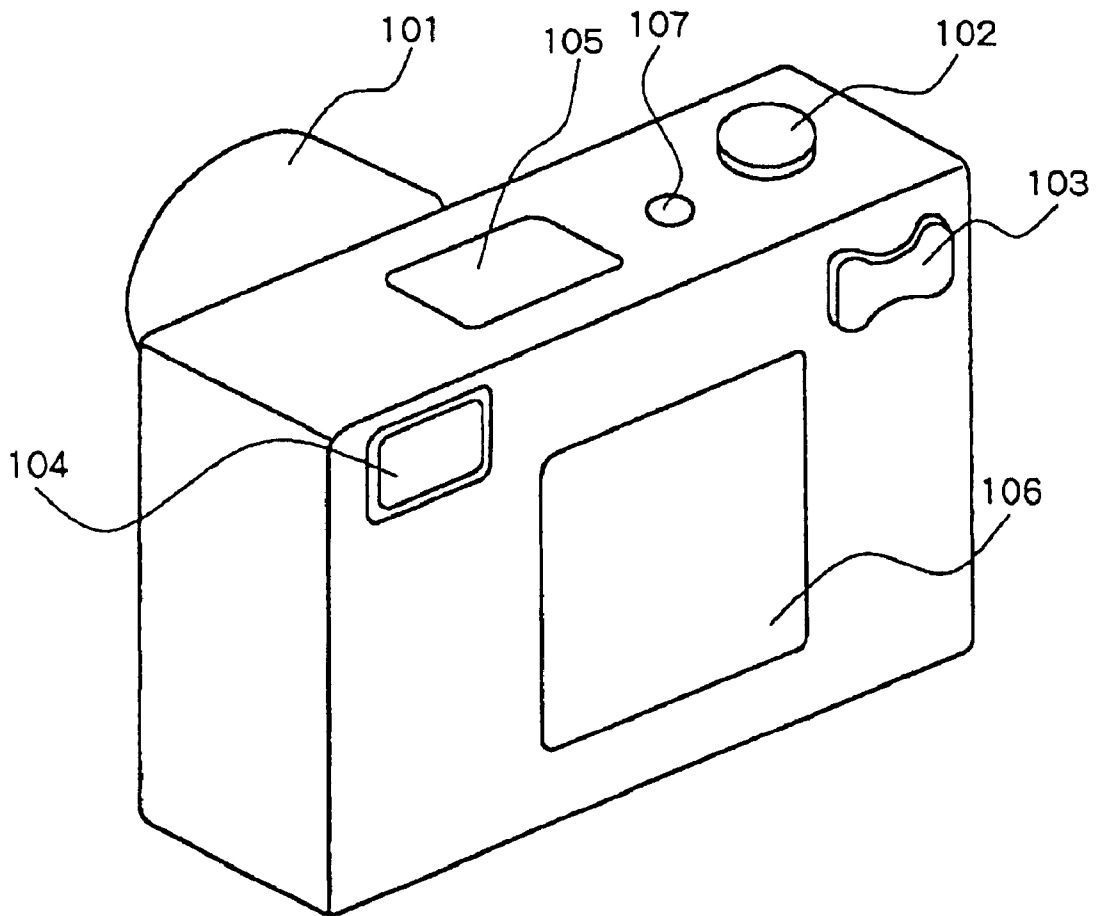

FIG.13



**VARIABLE FOCAL LENGTH LENS,
PHOTOGRAPHING LENS UNIT, CAMERA,
AND PORTABLE INFORMATION TERMINAL
DEVICE**

Matter enclosed in heavy brackets [] appears in the original patent but forms no part of this reissue specification; matter printed in italics indicates the additions made by reissue.

CROSS-REFERENCE TO RELATED
APPLICATIONS

The present document incorporates by reference the entire contents of Japanese priority document, 2003-191519 filed in Japan on Jul. 3, 2003.

BACKGROUND OF THE INVENTION

1. Field of the Invention

The present invention relates to an improvement of a variable focal length lens such as a zoom lens that is used as a photographing optical system in various cameras including a so-called silver-salt camera. In particular, the present invention relates to a variable focal length lens that can be preferably used in cameras such as digital cameras and video cameras, and to a photographing lens unit, a camera, and a portable information terminal device that includes such a variable focal length lens.

2. Description of the Related Art

Recently, cameras such as digital cameras and electronic cameras have become common. Such a camera acquires a photograph of a subject image with a solid-state image pickup element such as a charge-coupled device (CCD) image pickup element to obtain image data of a still image or a moving image (movie image) and digitally records the image data in a nonvolatile semiconductor memory or the like. A flash memory is an example of the nonvolatile semiconductor memory. A traditional camera in which a conventional silver-salt film is used, that is, a silver-salt camera is gradually becoming outdated.

A market for such a digital camera has grown to be extremely large, and demands of users for the digital camera have been diversified. Above all, the users often demand for an improvement in image quality and miniaturization of the digital cameras.

To achieve the characteristics such as small size, light weight, and high performance, variable focal length lenses such as zoom lenses are often used in the digital cameras. Such a zoom lens generally has a two-lens group or three-lens group structure, i.e., a structure that includes only a few lenses. If the zoom lens includes lens groups having several lenses, when the lenses are moved in focusing, the advantage of miniaturization cannot be fully achieved, moreover, the operability become poor, because movement of a center of gravity of the lenses is large. Therefore, sometimes the focusing is performed by moving only some of the lens groups.

For example, zoom lenses have been disclosed in Japanese Patent Application Laid-Open Publication Nos. 2003-131134, 2003-107352, and 2003-35868 as zoom lenses that can be preferably used in digital cameras and are suitable for miniaturization. A typical zoom lens includes a first group optical system having a negative refracting power, a second group optical system having a positive refracting power, and a third group optical system having a positive refracting power. The first to the third group optical systems are sequen-

tially arranged from an object side. A stop is provided on the object side of the second group optical system that moves integrally with the second group optical system. The focal length of the zoom lens can be changed by changing the distance between the respective group optical systems.

The first group optical system includes a negative meniscus lens, a negative meniscus lens, and a positive lens that are sequentially arranged from the object side. The second group optical system includes a positive lens, a negative lens, a positive lens, and a positive lens that are sequentially arranged from the object side. The third group optical system includes one positive lens.

In the zoom lens disclosed in Japanese Patent Application Laid-Open Publication No. 2003-131134, an image side surface of the negative meniscus lens second from the object side of the first group optical system, a surface on the most object side of the second group optical system, a surface on the most image side of the second group optical system, and a surface on the object side of the third group optical system are formed as aspherical surfaces, respectively.

In another exemplary structure, the positive lens on the most object side and the negative lens adjacent to the positive lens of the second group optical system are formed as a cemented lens, and an image side surface of the negative meniscus lens second from the object side of the first group optical system, a surface on the most object side of the second group optical system, a surface on the most image side of the second group optical system, and a surface on the object side of the third group optical system are formed as aspherical surfaces, respectively.

In still another exemplary structure, the positive lens on the most object side and the negative lens adjacent to the positive lens of the second group optical system are formed as a cemented lens, and an image side surface of the negative meniscus lens second from the object side of the first group optical system, a surface on the most object side of the second group optical system, and a surface on the object side of the third group optical system are formed as aspherical surfaces, respectively.

In still another exemplary structure, the negative lens and the negative lens second from the image side adjacent to the negative lens of the second group optical system are formed as a cemented lens, and an image side surface of the negative meniscus lens second from the object side of the first group optical system, a surface on the most object side of the second group optical system, a surface on the most image side of the second group optical system, and a surface on the object side of the third group optical system are formed as aspherical surfaces, respectively.

In this way, in the technology disclosed in Japanese Patent Application Laid-Open Publication No. 2003-131134, the image surface is corrected by using the aspherical surface for the positive lens of the third group optical system. Japanese Patent Application Laid-Open Publication Nos. 2003-107352 and 2003-35868 disclose similar structures.

Thus, in the conventional technology, the image surface is corrected by using the aspherical surface for the positive lens of the third group optical system.

Although it is effective to use the aspherical surface for the third group optical system for correction of the image surface, deterioration of image performance due to the focusing occurs when the third group optical system is moved along an optical axis for focusing.

This point is explained in more detail below. When the third group optical system is used for focusing, it is necessary to secure an amount of movement of the third group optical system. For securing the amount of movement of the third

group optical system, one approach is to increase the distance between the second and the third group optical systems or to increase a refracting power of the third group optical system to reduce the amount of movement of the third group optical system. However, the total length of the zoom lens increases and it becomes bulky if the distance between the second and the third group optical systems is increased. On the other hand, the aberration correction becomes difficult if the refracting power of the third group optical system is increased.

SUMMARY OF THE INVENTION

It is an object of the present invention to solve at least the problems in the conventional technology.

A variable focal length lens according to one aspect of the present invention includes a first group optical system having a negative refracting power, a second group optical system having a positive refracting power, and a third group optical system having a positive refracting power, wherein the first through the third group optical systems are sequentially arranged from an object side; and a stop provided on the object side of the second group optical system and that moves integrally with the second group optical system. A focal length is changed by changing distances between the first through the third group optical systems and when performing focusing the third group optical system is moved along an optical axis, the first group optical system includes a negative meniscus lens, a negative meniscus lens, and a positive lens those are sequentially arranged from the object side, at least one surface of the two negative meniscus lenses being an aspherical surface, the second group optical system includes a cemented lens of a positive lens and a negative lens, a positive lens, and a positive lens those are sequentially arranged from the object side, a surface on the object side of the positive lens on the most object side being an aspherical surface, and the third group optical system includes one positive lens not including an aspherical surface.

A variable focal length lens according to another aspect of the present invention includes a first group optical system having a negative refracting power, a second group optical system having a positive refracting power, and a third group optical system having a positive refracting power, wherein the first through the third group optical systems are sequentially arranged from an object side; and a stop provided on the object side of the second group optical system and that moves integrally with the second group optical system. A focal length is changed by changing relative distances between the first through the third group optical systems and when performing focusing the third group optical system is moved along an optical axis, the first group optical system includes a negative meniscus lens, a negative meniscus lens, and a positive lens those are sequentially arranged from the object side, the second group optical system includes a cemented lens of a positive lens and a negative lens, a positive lens, and a positive lens those are sequentially arranged from the object side, the third group optical system includes one positive lens, at least one surface of the negative meniscus lens in the first group optical system and a surface on the most object side in the second group optical system being aspherical surfaces, and the third group optical system includes only a spherical lens.

A photographing lens unit, a camera, a portable information terminal device according to still another aspect of the present invention include the above variable focal length lens according to the present invention.

The other objects, features, and advantages of the present invention are specifically set forth in or will become apparent from the following detailed description of the invention when read in conjunction with the accompanying drawings.

BRIEF DESCRIPTION OF THE DRAWINGS

FIG. 1 is a side view of an optical system of a variable focal length lens according to a first embodiment of the present invention when the focal length is wide-angle end;

FIG. 2 is a side view of the optical system in FIG. 1 when the focal length is intermediate focal length;

FIG. 3 is a side view of the optical system in FIG. 1 when the focal length is telescopic end;

FIG. 4 is an aberration curve diagram showing various aberrations at the wide-angle end of the variable focal length lens in FIGS. 1 to 3;

FIG. 5 is an aberration curve diagram showing various aberrations at the intermediate focal length of the variable focal length lens in FIGS. 1 to 3;

FIG. 6 is an aberration curve diagram showing various aberrations at the telescopic end of the variable focal length lens in FIGS. 1 to 3;

FIG. 7 is a side view of an optical system of a variable focal length lens according to a second embodiment of the present invention when the focal length is wide-angle end;

FIG. 8 is a side view of the optical system in FIG. 7 when the focal length is intermediate focal length;

FIG. 9 is a side view of the optical system in FIG. 7 when the focal length is telescopic end;

FIG. 10 is an aberration curve diagram showing various aberrations at the wide-angle end of the variable focal length lens in FIGS. 7 to 9;

FIG. 11 is an aberration curve diagram showing various aberrations at the intermediate focal length of the variable focal length lens in FIGS. 7 to 9;

FIG. 12 is an aberration curve diagram showing various aberrations at the telescopic end of the variable focal length lens in FIGS. 7 to 9; and

FIG. 13 is a perspective view from a photographer side schematically showing an external structure of a camera according to a third embodiment of the present invention.

DETAILED DESCRIPTION

Exemplary embodiments of a variable focal length lens, a photographing lens unit, a camera, and a portable information terminal device of the present invention will be hereinafter explained in detail with reference to the accompanying drawings. The principle of the present invention will be explained first.

The variable focal length lens according to the present invention is, in general, a zoom lens. This variable focal length lens includes a first group optical system having a negative refracting power, a second group optical system having a positive refracting power, and a third group optical system having a positive refracting power that are sequentially arranged from an object side, and a stop provided on the object side of the second group optical system that moves integrally

5

[TABLE 2

Combination	Type of Information				
	Number	(1)	(2)	...	(k)
1		Y_{11}	Y_{12}	...	Y_{1k}
2		Y_{21}	Y_{22}	...	Y_{2k}
.				...	
.				...	
n		Y_{n1}	Y_{n2}	...	Y_{nk}
Average		0	0	...	0
Standard Deviation		1	1	...	1]

[All correlation coefficients r_{pq} ($=r_{qp}$) between two combinations of data of k combinations of data are calculated using an expression (2), and are expressed by a matrix R (step 2-3). In addition, the inverse matrix of the matrix R of the correlation coefficients is calculated. The result obtained is expressed by a matrix A (step 2-4). "Σ" in the expression (2) indicates a summation related to a suffix i.]

$$r_{pq} = r_{qp} = \frac{\sum (Y_{ip} Y_{iq})}{(\sum Y_{ip}^2 \sum Y_{iq}^2)^{1/2}} \quad (2)$$

[Correlation Coefficient Matrix]

$$R = \begin{pmatrix} 1 & r_{12} & r_{13} & \dots & r_{1k} \\ r_{21} & 1 & r_{23} & \dots & r_{2k} \\ r_{31} & r_{32} & 1 & \dots & r_{3k} \\ \vdots & \vdots & \vdots & \ddots & \vdots \\ r_{k1} & r_{k2} & r_{k3} & \dots & 1 \end{pmatrix} \quad (3)$$

[Inverse Matrix]

$$A = \begin{pmatrix} a_{11} & a_{12} & a_{13} & \dots & a_{1k} \\ a_{21} & a_{22} & a_{23} & \dots & a_{2k} \\ a_{31} & a_{32} & a_{33} & \dots & a_{3k} \\ \vdots & \vdots & \vdots & \ddots & \vdots \\ a_{k1} & a_{k2} & a_{k3} & \dots & a_{kk} \end{pmatrix} \quad (4)$$

[With the calculations, the values of parameters calculated in a calculation expression, used when only the index value is calculated, is determined. Since all the data groups handled here express a normal state, it is considered that the various pieces of information acquired have a predetermined correlation. When the current state is far from the normal state and is likely to cause an abnormal state such as a failure, the correlations between the parameters are disturbed, and "distances" from original values (averages in a stable state) in the multi-dimensional spaces defined above increase. The distances represent the index values.]

[FIG. 4 is a flowchart of a procedure for calculating the index value in step 1-2 in FIG. 2. An index value at an arbitrary timing is calculated as follows. Data x_1, x_2, \dots, x_k of k types in an arbitrary state are acquired (step 3-1). The types of the data correspond to $y_{11}, y_{12}, \dots, y_{1k}$ or the like. The information acquired is standardized using an expression (5) (step 3-2). In this case, the standardized data are defined as X_1, X_2, \dots, X_k . A calculation expression (6) that is determined using elements a_{kk} of the inverse matrix A, is used to

6

calculate an index value D^2 . A value D that is the square root of the index value is called "Mahalanobis's distance". "Σ" in the expression (6) indicates a summation related to the suffixes p and q.]

$$X_r = (x_r - y_j) / \sigma_j \quad (5)$$

$$[D^2 = (1/k) \sum a_{pq} X_p X_q] \quad (6)$$

[The process of determining the calculation method for the index values includes determining the calculation expression for the index values and calculating the index value D using the calculation expression to update the index value D. This process may be continuously executed while the image forming system 6 is operated. In such case, the flow chart of the processes is obtained by combining the steps in FIG. 2 and those in FIG. 3.]

[FIG. 6 illustrates a configuration of a color copying machine according to an embodiment of the present invention. The color copying machine serves as an image forming apparatus that uses an electronic photographing scheme. The image forming system 6 (see FIG. 1) serving as the image forming unit of the color copying machine includes a printer unit 100, a paper feeding unit 200, a scanner unit 300, and an original convey unit 400. The scanner unit 300 is fixed on the copying machine main body. An original convey unit 400 constituted by an original automatic convey device (ADF) is fixed on the scanner unit 300. In addition, the copying machine main body also includes the control unit 5 (see FIG. 1) that controls the operations of the various devices in the color copying machine. The control unit 5 includes a CPU, a RAM, a ROM, an I/O interface unit, and the like as described above.]

[In the scanner unit 300, a read sensor 36 reads the image information of an original document placed on a contact glass 32 and transmits the image information read to the control unit. A laser, an LED, or the like (not shown) is arranged in an exposure device 21 in the printer unit 100. The control unit controls the laser, the LED or the like, on the basis of the image information received from the scanner unit 300, to irradiate a laser write beam L on photosensitive drums 40Bk, 40Y, 40M, and 40C. With this irradiation, electrostatic latent images are formed on the surfaces of the photosensitive drums 40Bk, 40Y, 40M, and 40C, and the latent images are developed into toner images by a predetermined developing process.]

[In addition to the exposure device 21, the printer unit 100 includes a primary transfer device 62, a secondary transfer device 22, a fixing device 25, a delivery device, a toner supply device (not shown), and the like. The developing process will be described later in detail.]

[The paper feeding unit 200 includes paper feeding cassettes 44 held in a plurality of levels in a paper bank 43, a paper feeding roller 42 that forwards transfer paper P, which serves as a recording medium, from a paper feeding cassette, a separation roller 45 that separates the transfer paper P forwarded to send the transfer paper P along a paper feeding path 46, a convey roller 47 that conveys the transfer paper P to a feeding path 48 of the printer unit 100, and the like. In the apparatus according to the embodiment, in addition to the paper feeding unit 200, a manual paper feeding tray 51 that is used for feeding paper manually and a separation roller 52 that separates sheets of transfer paper P on the manual paper feeding tray one by one toward a manual paper feeding path 53, are arranged on a side surface of the apparatus. A resist roller 49 delivers only one sheet of transfer paper P placed on the paper feeding cassette 44 or the manual paper feeding tray 51, and sends the sheet of transfer paper to a secondary

transfer nip portion located between an intermediate transfer belt 10 serving as an intermediate transfer body and the secondary transfer device 22.]

[In the configuration, when a color image is to be copied, an original document is set on an original table 30 of the original convey unit 400. Alternatively, the original convey unit 400 is opened to set the original document on the contact glass 32 of the scanner unit 300, and the original convey unit 400 is closed to press the original document. When a start switch (not shown) is pressed, the original document is conveyed onto the contact glass 32 if the original document is set on the original convey unit 400. On the other hand, if the original document is set on the contact glass 32, the scanner unit 300 is immediately driven to cause a first moving body 33 and a second moving body 34 to move. The first traveling body 33 reflects a beam from a light source, and a reflected beam from the surface of the original document is reflected to the second traveling body 34. The mirror of the second traveling body 34 reflects the beam and inputs the beam to the read sensor 36 through the image forming lens 35 to read image information. When the image information is received from the scanner unit, the laser writing and a developing process (to be described later) is performed to form toner images on the photosensitive drums 40Bk, 40Y, 40M, and 40C. At the same time, one of four resist-rollers is operated to feed the transfer paper P of a size depending on the image information read.]

[Accordingly, a drive motor (not shown) rotationally drives one of the support rollers 14, 15, and 16, that in turn rotate other two support rollers, and the intermediate transfer belt 10 is conveyed by the rotation of these rollers. At the same time, image forming units 18 rotate the photosensitive drums 40Bk, 40Y, 40M, and 40C to form single-color images of black, yellow, magenta, and cyan on the photosensitive drums 40Bk, 40Y, 40M, and 40C, respectively. With the conveyance of the intermediate transfer belt 10, these single-color images are sequentially transferred to form a synthesized color image on the intermediate transfer belt 10.]

[On the other hand, one of the paper feeding rollers 42 of the paper feeding unit 200 is selectively rotated to forward sheets of transfer paper P from one of the paper feeding cassettes 44. The separation roller 45 separates the sheets of transfer paper P and puts one sheet of transfer paper P at a time, into the feeding path 46. The convey roller 47 guides the sheet of transfer paper P to the feeding path 48 in the printer unit 100 and hits the sheet of transfer paper P against the resist roller 49 to stop the sheet of paper. Alternatively, a paper feeding roller 50 is rotated to forward sheets of transfer paper P on the manual paper feeding tray 51, separated by the separation roller 52, put into the manual paper feeding path 53, and hit against the resist roller 49 to stop the sheet of transfer paper P. The resist roller 49 is rotated at a timing matched with the timing when the synthesized color image is transferred on the intermediate transfer belt 10, and the sheet of transfer paper P is sent to the secondary nip portion that serves as a contact unit between the intermediate transfer belt and a secondary transfer roller 23. The color image is transferred by the influence of a transfer electric field and a contact pressure generated at the nip to record the color image on the sheet of transfer paper P.]

[The sheet of transfer paper P with the image is sent to the fixing device 25 over a convey belt 24 of the secondary transfer device. In the fixing device 25, a pressing roller 27 applies pressure and heat to the toner image to fix the toner image, and a delivery roller 56 delivers the sheet of transfer paper P onto a paper delivery tray 57.]

[The details of the printer unit 100 in the color copying machine according to the embodiment will be described below.]

[FIG. 7 is an enlarged view of a main part of the printer unit 100. The printer unit 100 includes an intermediate transfer belt 10 supported by three support rollers 14, 15, and 16, four photosensitive drums 40Bk, 40Y, 40M, and 40C serving as latent image carriers each of which carries a toner image of one of black, yellow, magenta, and cyan, and developing units 61Bk, 61Y, 61M, and 61C serving as developing units that form toner images on the drum surfaces. The printer unit 100 also includes photosensitive body cleaning devices 63Bk, 63Y, 63M, and 63C. Four image forming units 18Bk, 18Y, 18M, and 18C include the photosensitive drums 40Bk, 40Y, 40M, and 40C, the developing units 61Bk, 61Y, 61M, and 61C, and the photosensitive body cleaning devices 63Bk, 63Y, 63M, and 63C, respectively, and constitute a tandem image forming device 20. A belt cleaning device 17 removes residual toner remaining on the intermediate transfer belt 10 after a toner image is transferred to a sheet of transfer paper, and is arranged on the left of the support roller 15 in FIG. 7.]

[The belt cleaning device 17 has two fur brushes 90 and 91 as cleansing members. The fur brushes 90 and 91 ($\phi 20$ millimeters) are made of acrylic carbon (6.25 D/F), having a resistance of $\times 10^7$, and planted at 0.1 million/inch². The fur brushes 90 and 91 are arranged to be into contact with the intermediate transfer belt 10 and rotated. A power supply (not shown) applies biases having different polarities to the fur brushes 90 and 91. Metal rollers 92 and 93 are brought into contact with the fur brushes 90 and 91, respectively, to make it possible to rotate the metal rollers 92 and 93 in a forward or backward direction with respect to the fur brushes.]

[In the embodiment, a power supply 94 applies a negative voltage to the metal roller 92 on the upstream side of the intermediate transfer belt 10 in the rotating direction, and a power supply 95 applies a positive voltage to the metal roller 93 on the downstream side. The distal ends of blades 96 and 97 are brought into press contact with the metal rollers 92 and 93, respectively. When the intermediate transfer belt 10 rotates in the direction shown by an arrow in FIG. 7, the fur brush 90 on the upstream side is used first, to apply, for example, a negative bias, to thereby clean the surface of the intermediate transfer belt 10. If a voltage of -700 volts is applied to the metal roller 92, the fur brush 90 has a voltage of -400 volts, and positively charged toner on the intermediate transfer belt 10 can be transferred to the side of the fur brush 90. The toner transferred to the fur brush side is transferred from the fur brush 90 to the metal roller 92 by a potential difference, and the blade 96 scrapes out the toner.]

[In this manner, the fur brush 90 removes the toner on the intermediate transfer belt 10. However, a large amount of toner still remains on the intermediate transfer belt 10. The toner is negatively charged by a negative bias applied by the fur brush 90. It is considered that the toner is charged by injection of electric charge or discharge. Therefore, a positive bias is applied next, using the fur brush 91, to clean the intermediate transfer belt 10, to remove the remaining toner. The removed toner is transferred from the fur brush 91 to the metal roller 93 by a potential difference, and the toner is scraped out by the blade 97. The toner scraped out by the blades 96 and 97 is recovered and put in a tank (not shown). The toner may be returned to the developing device 61 by using a toner recycle device (to be described later).]

[Thus, as described above, although most of the toner is removed from the surface of the intermediate transfer belt 10 by cleaning with the fur brush 91, a small amount of toner still remains on the surface. The toner remaining on the interme-

mediate transfer belt 10 is positively charged by a positive bias applied to the fur brush 91. The positively charged toner is transferred to the photosensitive drums 40Bk, 40Y, 40M, and 40C by a transfer electric field applied at a primary transfer position, and can be recovered by the photosensitive body cleaning device 63.]

[A secondary transfer device 22 and the tandem image forming device 20 are arranged on the opposite sides of the intermediate transfer belt 10. The secondary transfer device 22 is constituted such that, in the embodiment, the convey belt 24 is booked between the two rollers 23. The secondary transfer device 22 is brought into press contact with the third support roller 16 through the intermediate transfer belt 10 to form a secondary transfer nip portion, and a color toner image on the intermediate transfer belt 10 is secondarily transferred onto a sheet of transfer paper P. After the secondary transfer, the residual toner on the intermediate transfer belt 10 is removed by the belt cleaning device 17. The intermediate transfer belt 10 prepares for the next image formation. The secondary transfer device 22 also includes function to carry a sheet of transfer paper P, on which the image is transferred, to the fixing device 25. A transfer roller or a non-contact charger may be arranged as the secondary transfer device 22. However, in such a case, it is difficult for the secondary transfer device 22 to execute a function of carrying the transfer paper P.]

[Commonly, the resist roller 49 with earthing is used. However, a bias can also be applied to remove paper powder from the transfer paper P. For example, the bias may be applied via a conductive rubber roller. Conductive NBR rubber having a diameter of $\phi 18$ millimeters and a surface thickness of 1 millimeter is used as the material of the rubber roller. An electric resistance is a volume resistance of the rubber material, i.e., about $10 \times 10^3 \Omega \cdot \text{cm}$, and an application voltage of about -800 volts is applied to a side (front surface side) to which toner is transferred. A voltage of $+200$ volts is applied to the rear surface of the paper.]

[In a general intermediate transfer system, paper powder does not easily move to a photosensitive drum. Therefore, the necessity of considering transfer of paper powder is less, and the photosensitive drum may be grounded. ADC bias is applied as the application voltage. However, an AC voltage having a DC offset may be used to charge the sheet of transfer paper P more uniformly. The paper surface applied with the bias and passing through the resist roller 49 is slightly negatively charged. Therefore, in transfer from the intermediate transfer belt 10 to the sheet of transfer paper P, the transfer conditions are different from those set when no voltage is applied to the resist roller 49, and the transfer conditions may be changed.]

[In the embodiment, a transfer paper reversing device 28 (see FIG. 6) that is arranged in parallel to the tandem image forming device 20, reverses the sheet of transfer paper P to record images on both the surfaces of the sheet of transfer paper P. In this manner, after the image is fixed on one surface of the sheet of transfer paper, the course of the sheet of transfer paper is switched to the transfer paper reversing device side by a switching pawl. At this position, the sheet of transfer paper is reversed, and the toner image is transferred by the secondary transfer nip again. Thereafter, the sheet of transfer paper P may be delivered on the paper delivery tray.]

[The tandem image forming device 20 will be described below.]

[FIG. 8 is a partially enlarged view of the tandem image forming device 20. The four image forming units 18Bk, 18Y, 18M, and 18C have identical configurations, and hence, the four color symbols Bk, Y, M and C are omitted in the descrip-

tion that follows. The configuration of one of the units will be described in detail. As shown in FIG. 8, in the image forming unit, a charging device 60, a developing device 61, a primary transfer device 62, a photosensitive body cleaning device 63, an ionizer 64, and the like are arranged around the photosensitive drums 40Bk, 40Y, 40M, and 40C. Each of the photosensitive drums 40Bk, 40Y, 40M, and 40C, is formed by coating an organic photosensitive material on a material tube consisting of aluminum or the like to form a photosensitive layer. Alternatively, photosensitive drums 40Bk, 40Y, 40M, and 40C may be constituted by endless belts.]

[Although not shown, at least photosensitive drums 40Bk, 40Y, 40M, and 40C are arranged, and a process cartridge is constituted by including all or some of the units in the image forming unit 18. The image forming units 18 may be detachably arranged in the printer unit 100 at once to improve the maintenance properties. Of the units constituting the image forming units 18, the charging device 60 is in the form of a roller in the shown example and brought into contact with the photosensitive drums 40Bk, 40Y, 40M, and 40C to apply a voltage, to charge the photosensitive drums 40Bk, 40Y, 40M, and 40C. Alternatively, a non-contact Scorotron charger may also be used for charging the photosensitive drums.]

[A one-component developing agent may be used as the developing device 61. However, in the example shown, a two-component developing agent consisting of a magnetic carrier and non-magnetic toner is used. A stirring unit 66 conveys the two-component developing agent while stirring the two-component developing agent, supplies the two-component developing agent to a developing sleeve 65, and causes the two-component agent to adhere to the developing sleeve 65. A developing unit 67 transfers the toner of the two-component agent adhering the developing sleeve 65 to the photosensitive drums 40Bk, 40Y, 40M, and 40C. The stirring unit 66 is located at a level lower than that of the developing unit 67.]

[The stirring unit 66 has two parallel screws 68. A partition plate 69 partitions the two screws 68 in regions other than both the end portions. A toner concentration sensor 71 is arranged in a developing case 70.]

[In the developing unit 67, the developing sleeve 65 is arranged in opposition to the photosensitive drums 40Bk, 40Y, 40M, and 40C through an opening of the developing case 70, and a magnet 72 is fixed in the developing sleeve 65. A doctor blade 73 is arranged such that the distal end of the doctor blade 73 is close to the developing sleeve 65. In the example shown, an interval between the doctor blade 73 and the developing sleeve 65 at the closest portion is set to 500 micrometers.]

[The developing sleeve 65 is a non-magnetic rotatable sleeve. A plurality of magnets 72 are arranged in the developing sleeve 65. The magnet 72 is designed to cause magnetic force to act when the developing agent passes through a predetermined position. In the example shown, the diameter of the developing sleeve 65 is set to $\phi 18$ millimeters, and the surface of the developing sleeve 65 is subjected to a sandblast process or a process of forming a plurality of grooves each having a depth of 1 to several millimeters, so that a surface roughness (Rz) falls within the range of 10 to 30 micrometers.]

[The magnet 72 has five polarities N1, S1, N2, S2, and S3 in a direction from the position of the doctor blade 73 in the rotating direction of the developing sleeve 65. A magnetic brush, made of the developing agent and magnetized by the magnet 72, is supported on the developing sleeve 65. The developing sleeve 65 is arranged in opposition to the photo-

sensitive drums 40Bk, 40Y, 40M, and 40C in a region on S1 side of the magnet 72 that forms the magnetic brush for the developing agent.]

[With such configuration, the two-component developing agent is conveyed and circulated while being stirred by the two screws 68, and is supplied to the developing sleeve 65. The developing agent supplied to the developing sleeve 65 is scooped up and held by the magnet 72 to form a magnetic brush on the developing sleeve 65. The magnetic brush is thinned by the doctor blade 73 to have an appropriate amount with rotation of the developing sleeve 65. The cut developing agent is returned to the stirring unit 66.]

[The toner of the developing agent supported on the developing sleeve 65 is transferred to the photosensitive drums 40Bk, 40Y, 40M, and 40C by applying a developing bias voltage to the developing sleeve 65 to change the electrostatic latent images on the photosensitive drums 40Bk, 40Y, 40M, and 40C into visible images. After the visible images are formed, a developing agent remaining on the developing sleeve 65 is separated from the developing sleeve 65 out of the magnetic force of the magnet 72, and returned to the stirring unit 66. As the operations are repeated, the toner concentration in the stirring unit 66 decreases. The toner concentration sensor 71 detects the toner concentration, and toner is supplied to the stirring unit 66.]

[In the apparatus according to the embodiment, the following settings of the units are made. The linear velocity of each of the photosensitive drums 40Bk, 40Y, 40M, and 40C is set at 200 mm/s. The linear velocity of the developing sleeve 65 is set at 240 mm/s. The diameter of each of the photosensitive drums 40Bk, 40Y, 40M, and 40C is set at 50 millimeters, and the diameter of the developing sleeve 65 is set at 18 millimeters. The developing process is performed with these settings. An amount of charge of toner on the developing sleeve 65 preferably falls within the range of -10 to -30 $\mu\text{C/g}$. A developing gap GP, that is, each of gaps between the photosensitive drums 40Bk, 40Y, 40M, and 40C and the developing sleeves 65 can be set to fall within the range of 0.8 millimeter to 0.4 millimeter as in a conventional art. Reducing the developing gap GP improves the developing efficiency. In addition, the thickness of the photosensitive body 40 is set at 30 micrometers, the beam spot diameter of an optical system is set at 50 to 60 micrometer, and light intensity is set at 0.47 mW. A charging potential before exposure V0 of the photosensitive body 40 is set at -700 volts, potential after exposure VL is set at -120 volts, and a developing bias potential is set at -470 volts, i.e., a developing potential is 350 volts. A developing process is performed with these settings.]

[The roller-shaped primary transfer roller 62 is arranged to be in press contact with the photosensitive body 40 through the intermediate transfer belt 10. An electric conductive roller 74 is arranged between the primary transfer devices 62 such that the electric conductive roller 74 is brought into contact with a base layer U of the intermediate transfer belt 10. The image forming units 18 are adjacent to the primary transfer devices 62. Therefore, the electric conductive roller 74 prevents biases, applied by the primary transfer devices 62 in transfer, from flowing in the image forming units 18 through the base layer U having an intermediate resistance.]

[A cleaning blade 75 is made of polyurethane rubber. The photosensitive body cleaning device 63 brings the distal end of the cleaning blade 75 into press contact with the photosensitive body 40. In addition, a fur brush 76, having contact conductivity and an external periphery being in contact with the photosensitive body 40, is rotatably arranged in the direction of an arrow shown in FIG. 8, to thereby improve cleaning properties. A metal electric field roller 77 applies a bias to the

fur brush 76, and is arranged such that the metal electric field roller 77 can be rotated in the direction of the arrow shown. The distal end of a scraper 78 is brought into press contact with the metal electric field roller 77. A recovery screw 79 that recovers the removed toner is also arranged in the photosensitive body cleaning device 63.]

[In the photosensitive body cleaning device 63 with such configuration, the fur brush 76 that rotates in the direction opposite to that of the photosensitive body 40 removes residual toner on the photosensitive body 40. The electric field roller 77 that is in contact with the fur brush 76, applies a bias, and rotates in the direction opposite to that of the fur brush 76, to thereby remove the toner adhering to the fur brush 76. The scraper 78 cleans the electric field roller 77 and removes the toner adhering to the electric field roller 77. The recovery screw 79 collects the toner, recovered by the photosensitive body cleaning device 63, on one side of the photosensitive body cleaning device 63. A toner recycle device 80 returns the toner collected to the developing device 61, and recycles the toner returned.]

[The ionizer 64 uses an ionizing lamp to irradiate a beam on the photosensitive drum 40, to thereby initialize the surface potential of the photosensitive drum 40.]

[The image forming process, in the tandem image forming device 20 with the above configuration, is performed as follows. With rotation of the photosensitive drum 40, the charging device 60 uniformly charges the surface of the photosensitive drum 40, and a write beam L is irradiated on the photosensitive drum 40 to form an electrostatic latent image on the photosensitive drum 40. Thereafter, the developing device 61 performs developing to cause the toner to adhere to the electrostatic latent image, and forms a toner image. The primary transfer device 62 primarily transfers the toner image onto the intermediate transfer belt 10. The photosensitive body cleaning device 63 removes residual toner from the surface of the photosensitive drum 40 after the image transfer, and the ionizer 64 ionizes the surface to prepare image formation again. On the other hand, the residual toner removed from the surface of the photosensitive drum is re-used in developing by a toner recycle device (to be described later). An order of colors forming an image is not limited to the order described above. The order changes depending on objects or characteristics held in the image forming apparatus.]

[The type of information to be acquired for predicting occurrence of an abnormal state in the color copying machine having the above configuration and an acquiring method will be described below.]

[(a) About Sensing Information]

[A drive relationship, various characteristics of a recording medium, characteristics of a developing agent, characteristics of a photosensitive body, various process states of an electronic photograph, an environmental condition, various characteristics of a recording object, and the like are considered as the sensing information to be acquired. The outline of the pieces of sensing information will be described below.]

[(a-1) Information of Drive]

[A rotating speed of a photosensitive drum is detected by an encoder, a current value of a drive motor is read, and a temperature of the drive motor is read.]

[Similarly, drive states of cylindrical or belt-like rotatable units such as a fixing roller, a paper convey roller, and a drive roller are detected.]

[A microphone installed inside or outside the apparatus detects the sound generated by a drive.]

[(a-2) State of Paper Conveyance]

[The positions of the front and rear ends of conveyed paper are read by a transmissive or reflective photo-sensor or a

contact type sensor, to detect occurrence of paper jam or to read a difference between pass timings of the front and rear ends of the sheet of paper and a change of a direction vertical to a transmission direction.]

[Similarly, on the basis of the timings detected by the sensors, a moving speed of the sheet of paper is calculated.] 5

[Slit between a paper feed roller and a sheet of paper in paper feeding is calculated by comparing a value obtained by measuring a rotating speed of the roller with a moving distance of the sheet of paper.]

[(a-3) Various Characteristics of Recording Medium Such As Paper]

[This information considerably affects image quality and the stability of paper conveyance. The information about the paper is acquired by the following methods.]

[The thickness of the sheet of paper is calculated by the following method. The sheet of paper is pinched by two rollers, relative displacements of the roller are detected by an optical sensor, or a displacement which is equal to a moving distance of a member lifted up by insertion of the sheet of paper is detected.] 10

[The surface roughness of the sheet of paper is calculated by the following method. A guide or the like is brought into contact with the surface of the sheet of paper before transfer, and vibration, sliding sound, or the like generated by the contact is detected.] 20

[The gloss of the sheet of paper is calculated by the following method. A light flux having a predetermined open angle is incident at a predetermined incident angle. The light flux reflected in a reflecting direction of a mirror surface and having a predetermined open angle, is measured by a sensor.] 25

[The rigidity of the sheet of paper is calculated by detecting a transformation ratio (curvature) of the pressed sheet of paper.] 30

[To decide whether the paper is a sheet of recycled paper, an ultraviolet ray is irradiated on the sheet of paper and the transmittance of the sheet of paper is detected.] 35

[To decide whether the paper is a sheet of backing paper, a beam is irradiated from a linear beam source such as an LED array, and a beam reflected from a transfer surface is detected by a solid-state image pickup element such as a CCD.] 40

[To decide whether the paper is a sheet of paper for OHP, a beam is irradiated on the sheet of paper to detect a regularly reflected beam having an angle different from that of a transmitted beam.] 45

[Moisture content of the sheet of paper is calculated by measuring absorption of infrared or a μ -wave beam.]

[A photo-sensor, a contact sensor, or the like detects an amount of curl.] 50

[An electric resistance of the sheet of paper is obtained by the following method. A pair of electrodes (paper feeding rollers or the like) is brought into contact with a sheet of recording paper to directly measure the electric resistance. Alternatively, the surface potential of the photosensitive body or the intermediate transfer body after paper transfer is measured to estimate the resistance of the sheet of recording paper, based on the surface potential.] 55

[(a-4) Developing Agent Characteristics]

[The characteristics of a developing agent (toner carrier) in the apparatus have a major effect on the functioning of an electronic photographing process. Therefore, the characteristics of the developing agent serve as an important factor for an operation or an output of the system. It is very important to obtain the information about the developing agent. The characteristics of the developing agent are given below.] 60

[With respect to a toner, charge amounts, a distribution of charge amounts, fluidity, a degree of agglutination, dimensional concentration, an electric resistance, an external additive content, a consumption of external additive or a remaining amount of external additive, fluidity, a toner concentration (mixture ratio of toner and a carrier) are cited.]

[With respect to a carrier, magnetic characteristics, a coat thickness, an amount of spent, and the like are cited.]

[It is generally difficult to independently detect the items in the image forming apparatus. Therefore, these items are detected as integrated characteristics. An example method to measure the integrated characteristics of the developing agent is described below.]

[A test latent image is formed on a photosensitive body and developed under predetermined developing conditions, and a reflection concentration (optical reflectance) of the toner image formed is measured.] 15

[A pair of electrodes is arranged in the developing device to measure a relationship between an application voltage and a current (resistance, dielectric constant, or the like).]

[A coil is arranged in the developing device to measure voltage-current characteristics (inductance).]

[A level sensor is arranged in the developing device to detect a developing agent capacity. An optical level sensor, an electric capacitance type level sensor, or the like is used as the level sensor.] 20

[(a-5) Photosensitive Body Characteristics]

[Like the developing agent characteristics, the photosensitive body characteristics are closely related to the functioning of an electronic photographing process. A thickness of a photosensitive body, surface characteristics (friction coefficient and unevenness), surface potentials (before and after the processes), surface energy, scattering light, a temperature, a color, a surface position (fluctuation), a linear velocity, a potential attenuation rate, a resistance/capacitance, a surface moisture content, and the like are cited as the pieces of information of the photosensitive body characteristics. Of these items, the following pieces of information can be detected in the image forming apparatus.] 30

[A change of the electric capacitance with a change in thickness collates with voltage-current characteristics between a detected current flowing from a charged member to a photosensitive body and a voltage simultaneously applied to the charged member with respect to a dielectric thickness of a predetermined photosensitive body, to thereby calculate a film thickness.] 35

[The surface potential and the temperature can be calculated by a conventionally known sensor.]

[The linear velocity is detected by an encoder fixed to the rotating shaft of the photosensitive body.] 40

[Light scattering from the surface of the photosensitive body is detected by a photo-sensor.]

[(a-6) Electronic Photographing Process State]

[Formation of a toner image by an electronic photographing scheme is performed in the following order. That is, uniform charging of a photosensitive body, latent image formation (image exposure) by a laser beam or the like, developing by a charged toner (color particles), transfer of the toner image to a transfer material (for a color image, overlapping on a recording medium serving as an intermediate transfer body or a final transfer material or overlapping developing on the photosensitive body in developing is performed), and fixing of the toner image to the recording medium. Various pieces of information about these stages considerably affect the image and other outputs from the system. It is important to acquire the pieces of information, to evaluate the stability of the 65

15

system. The following are concrete examples of acquiring the pieces of information of the electronic photographing process state.]

[A conventionally known surface potential sensor detects a charge potential and a potential of an exposing unit.]

[A gap between a charged member and a photosensitive body in non-contact charging is detected by measuring an amount of light caused to pass through the gap.]

[A wide-band antenna captures an electromagnetic wave generated by charging.]

[Sound generated by charging]

[Exposure strength]

[Wavelength of exposure light]

[The following are methods of acquiring various states of a toner image.]

[To calculate a pile height (height of a toner image), a displacement sensor calculates a depth in the vertical direction, and a linear sensor for parallel beams measures a light-shielding length in the horizontal direction.]

[A toner charge amount is calculated by a ratio of a potential of an electrostatic latent image of an all-overlying portion to an amount of adhesion which is measured by a potential sensor that measures a potential in a developing state of the latent image and which is converted from a reflection concentration sensor at the same position.]

[A dot fluctuation or a dot gap is calculated by the following method. An infrared area sensor detects a dot pattern image on a photosensitive body. An area sensor that has wavelengths depending on colors on an intermediate transfer body detects the dot pattern, and an appropriate process is performed.]

[To calculate an amount of offset (after fixing), the corresponding positions on a sheet of recording paper and a fixing roller are read out by an optical sensor and compared with each other.]

[An optical sensor is installed after the transfer process (on a PD or on a belt), and a remaining amount of transfer is decided by an amount of reflected light from a transfer remaining pattern obtained after a specific pattern is transferred.]

[Color unevenness in overlapping is detected by a full-color sensor that detects a fixed image on the sheet of recording paper.]

[(a-7) Characteristic of Toner Image Formed]

[An image concentration and a color are optically detected (Any one of a reflectance and a transmittance may be used. A projecting wavelength is selected depending on a color). A concentration and monochromatic information may be obtained on a photosensitive body or an intermediate transfer body. However, a combination of colors such as color unevenness must be measured on a sheet of paper.]

[To calculate tone property, an optical sensor reflection detects concentration of toner images formed on a photosensitive body at tone levels or toner images transferred to a transfer body.] *with the second group optical system, changes the focal length by changing the relative spacing of the group optical systems, and in order to focus moves the third group optical system along the optical axis. In a variable-focal-length lens of this type, the first group optical system is so constituted that it has a negative meniscus lens, a negative meniscus lens, and a positive lens arranged in that order from the object side, an aspheric surface being formed on at least one surface among the two negative meniscus lenses; the second group optical system is so constituted that it has a cemented lens of a positive lens and a negative lens, a positive lens, and a positive lens arranged in that order from the object side, forming an*

16

aspheric surface on the surface on the object side of the positive lens that is most on the object side; and the third group optical system consists of a single positive lens that does not include an aspheric surface (corresponding to claim 1).

That is, typically with this composition, in a variable-focal-length lens of the type described above, the first group optical system is so constituted that it has a negative meniscus lens, a negative meniscus lens, and a positive lens arranged in that order from the object side; the second group optical system is so constituted that it has a cemented lens of a positive lens and a negative lens, a positive lens, and a positive lens arranged in that order from the object side; and the third group optical system consists of a single positive lens. In addition, an aspheric surface is formed on at least one surface of the negative meniscus lenses in the first optical system and on the surface that is most on the object side in the second group optical system; and the third optical system is constituted with only a spherical lens (corresponding to claim 2).

When this is done, it becomes possible to easily make corrections in image surface by giving the positive lens of the third group optical system a meniscus shape (corresponding to claim 3).

Also, particularly satisfactory correction is possible under the condition that

$$-0.75 < |(R1 - R2) / (R1 + R2)| < -0.65 \quad (1)$$

where R1 is the radius of curvature of the object-side surface of the positive lens of the third group optical system, and R2 is the radius of curvature of the image-side surface of the positive lens of the third group optical system (corresponding to claim 4). If the lower limit of this condition formula (1) is not satisfied, the surrounding image surface will fall on the plus side, that is, in the direction away from the object, and if it exceeds the upper limit, the surrounding image surface will fall on the minus side.

Also, it is possible to shorten the minimum picture-taking distance while minimizing the increase in overall length, and to make satisfactory aberration corrections, under the condition that

$$1.5 < |(D23w \times f3) / fw^2| < 2.5 \quad (2)$$

where D23w is the distance between the second group optical system and the third group optical system at the wide-angle end, fw is the focal length of the entire system at the wide-angle end, and f3 is the focal length of the third group optical system. If the upper limit of this condition formula (2) is exceeded, it becomes difficult to obtain a good image, due to an increase in the Petzval sum and an increase in the negative distortion aberration, and if the lower limit is not satisfied, distortion correction becomes difficult because the refractive power of the third group optical system becomes too strong to ensure the spacing between the second group optical system and the third group optical system (corresponding to claim 5).

If a picture-taking lens system is made using a variable-focal-length lens such as described above as an optical system, a picture-taking lens unit can be made that can satisfactorily correct aberrations, can have a short minimum picture-taking distance and a wide picture-taking range, and can have a low-cost, compact configuration (corresponding to claim 6).

Also, if a camera is made using a variable-focal-length lens such as described above as a picture-taking optical system, a camera can be made that can satisfactorily correct aberrations, can have a short minimum picture-taking distance and a wide picture-taking range, and can be low-cost and compact (corresponding to claim 7).

Similarly, if a portable information terminal is put together using a variable-focal-length lens such as described above as the picture-taking optical system of a camera function unit, a portable information terminal can be made that can satisfactorily correct aberrations, can have a short minimum picture-taking distance and a wide picture-taking range, and can be low-cost and compact (corresponding to claim 8).

WORKING EXAMPLES

Next, we describe in detail specific working examples, based on the above embodiments of this invention. The first and second working examples discussed below are also the first and second embodiments and at the same time are working examples of specific configurations according to examples of specific numerical values for the variable-focal-length lens of this invention, and the third working example is an embodiment of a camera or portable information terminal of this invention that adopts in its picture-taking optical system the picture-taking lens unit of this invention using a variable-focal-length lens such as shown in the first and second working examples.

The first and second working examples showing the variable-focal-length lens of this invention show the composition of the variable-focal-length lens and examples of its specific numerical values.

Aberration is fully corrected in the first and second working examples. It will become clear from these first and second working examples that by putting together a variable-focal-length lens as in this invention, it will be possible to ensure very good imaging performance while achieving satisfactory small size.

The following symbols are used in the descriptions relating to the first and second embodiments below.

An aspheric surface is defined by the following formula, where H is the height from the optical axis, S is the amount of displacement from the plane vertex in the direction of the optical axis, R is the radius of curvature, and A_2 is the asphericity.

[Numerical formula 1]

$$S = \frac{(1/R)xH^2}{1 + \sqrt{1 - (1/R)^2 xH^2}} + \sum_i A_{2i} xH^{2i} \quad (3)$$

First Working Example

FIGS. 1, 2, and 3 show the composition of the optical system of the variable-focal-length lens of the first working example of this invention at, respectively, the single-focal-length [sic; possibly a misprint for "short-focal-length"] end, that is, the wide-angle end, at the middle focal length, and at the long-focal-length end, that is, the telephoto end.

The variable-focal-length lens shown in FIG. 1 to FIG. 3 have first lens E1, second lens E2, third lens E3, fourth lens E4, fifth lens E5, sixth lens E6, seventh lens E7, eighth lens E8, diaphragm FA, and optical filter OF. In this case, the first lens E1 to the third lens E3 constitute the first group optical system G1, the fourth lens E4 to the seventh lens E7 constitute the second group optical system G2, the eighth lens E8 constitutes the third group optical system G3, they are supported by a support frame, etc. that is suitably shared by each group, and the groups move as one when zooming, etc. Also, the surface number of each optical surface is also shown in FIG. 1 to FIG. 3.

In FIG. 1 to FIG. 3, the components are arranged in order, from the side of the object such as the photo subject, first lens E1, second lens E2, third lens E3, diaphragm FA, fourth lens E4, fifth lens E5, sixth lens E6, seventh lens E7, eighth lens E8, and optical filter OF, and the image is formed on the back of the optical filter OF, which has various optical filtering functions.

The first lens E1 is a negative meniscus lens shaped convex on the object side, the second lens E2 is a negative meniscus lens shaped convex on the object side, and the third lens E3 is a positive lens consisting of a plano-convex lens that is convex toward the object side; the first optical system G1, which consists of these lenses, first lens E1 to third lens E3, exhibits negative refractive power as a whole. The fourth lens E4 is a positive lens made up of a biconvex lens that is strongly convex toward the object side; for example, it is a hybrid aspheric surface lens that is made up of glass lenses and forms an aspheric surface with a resin material formed on its object-side surface. The fifth lens E5 is a negative lens made up of a biconcave lens that is strongly concave toward the image side; these lenses, fourth lens E4 and fifth lens E5, are cemented into one, being affixed together so as to form a (two-ply) cemented lens. The sixth lens E6 is a positive lens made up of a biconvex lens, and the seventh lens E7 is a positive lens made up of a biconvex lens that is strongly convex toward the image side. The second group optical system G2, which consists of this three-group four-lens composition of fourth lens E4 to seventh lens E7, exhibits positive refractive power as a whole. The diaphragm FA, which is arranged on the object side of the second group optical system G2, moves as one with the second group optical system G2. The eighth lens E8 is a positive meniscus lens formed to be convex on the object side, and the third group optical system G3, which is made up of only this eighth lens E8, exhibits positive refractive power.

In changing the focal length from the wide-angle end (short-focus end) to the telephoto end (long-focus end), the first group optical system G1 moves toward the object so as to describe a concave locus, and the second group optical system G2 moves monotonically toward the object. In focusing from infinity to a near-distance object, the third group optical system G3 is moved along the optical axis toward the object. The optical filter OF, which is made up of parallel flat plates positioned the most on the image side, is various filters such as a crystal low-pass filter or an infrared cutoff filter. As the focal length changes, the movement of the groups changes the spacing between the groups, specifically: the spacing D12 between the surface most on the image side of the first group optical system G1, that is, the image-side surface (surface number 6) of the third lens E3, and the object-side surface (surface number 7) of the diaphragm FA that is integral with the second group optical system G2; the spacing D23 between the surface most on the image side of the second group optical system G2, that is, the image-side surface (surface number 15) of the seventh lens E7, and the surface most on the object side of the third group optical system G3, that is, the object-side surface (surface number 16) of the eighth lens E8; and the spacing D3F between the surface most on the image side of the third group optical system G3, that is, the image-size surface (surface number 17) of the eighth lens E8, and the object-side surface (surface number 18) of the optical filter OF.

In this first working example, as the focal length changes from the wide-angle side to the telephoto side, other measurements change as well, including
 overall focal length: from 4.33 to 12.22 mm
 F number: from 2.69 to 4.53
 half face angle: from 40° to 16°.

The properties of each optical surface are as in the following table.

[Table 1]
Optical properties

Surface	Radius of curvature	Spacing	Refractive index	Abbe number		
1	33.126	1.00	1.71300	53.94	1 st lens	1 st group optical system
2	6.300	1.35	1.00000			
3	15.009	1.00	1.80610	40.74	2 nd lens	
4*	5.101	1.50	1.00000			2 nd group optical system
5	9.600	2.47	1.76182	26.60	3 rd lens	
6	0.000	13.54	1.00000			
7	0.000	0.80	1.00000		diaphragm	3 rd group optical system
8*	5.828	0.03	1.50703	53.43	(resin)	
9	6.146	3.09	1.72342	37.99	4 th lens	
10	-37.803	1.90	1.84666	23.78	5 th lens	5 th group optical system
11	5.600	0.35	1.00000			
12	13.385	2.03	1.48749	70.44	6 th lens	
13	-13.385	0.10	1.00000			6 th group optical system
14	48.080	1.35	1.48749	70.44	7 th lens	
15	-18.370	1.50	1.00000			
16	12.227	1.75	1.51680	64.20	8 th lens	8 th group optical system
17	77.178	2.10	1.00000			
18	0.000	0.48	1.54892	69.13	Filter	
19	0.000	0.34	1.54892	69.13		Filter
20	0.000	0.50	1.50000	64.00		
21	0.000					

The optical surfaces of surfaces 4 and 8 whose surface number is marked with an asterisk (*) in Table 1 are aspheric surfaces, and the parameters of each aspheric surface in formula (3) are as in the following table.

[Table 2] Asphericities

Surface		4	8
Asphericity	A ₄	-1.07237E-03	-4.94747E-04
	A ₆	-2.62545E-05	-1.37113E-05
	A ₈	-1.39674E-08	8.40768E-07
	A ₁₀	-4.22743E-08	-2.81080E-08
	A ₁₈	-3.64892E-14	0.

The spacing D12 between the first group optical system G1 and the diaphragm FA, which is integral with the second group optical system G2, the spacing D23 between the second group optical system G2 and the third group optical system G3, and the spacing D3F between the third group optical system G3 and the optical filter OF change as in the following table when the focal length changes.

[Table 3] Variable spacing

TABLE 3

Variable spacing			
Surfaces	Wide-angle end	Middle	Telephoto end
D12	13.54	5.56	1.20
D23	1.50	6.30	15.87
D3F	3.87	3.67	1.75

Also, the following are the numerical values of $\frac{1}{R1+R2}$ in condition formula (1) and of $\frac{1}{(D23w \times f3) / fw^2}$ in condition formula (2) referred to above in this first working example.

Condition formula numerical values:

(1) formula = -0.726

(2) formula = 2.23

Therefore the numerical values for the condition formulas of this invention referred to above in this first working example all lie within the range of the condition formulas.

FIG. 4 to FIG. 6 are aberration curve diagrams for the aberrations of the variable-focal-length lenses shown in FIG. 1 to FIG. 3 of the above first working example; FIG. 4 is an aberration curve diagram at the wide-angle end, FIG. 5 is an aberration curve diagram in the middle focal length, and FIG. 6 is an aberration curve diagram at the telephoto end. In each aberration curve diagram, in the spherical surface aberration diagram the dotted line represents the sine condition, and in the stigmatic diagram the solid line represents the saggital, and the dotted line represents the meridional.

According to these aberration curve diagrams in FIG. 4 to FIG. 6, it is clear that aberration is satisfactorily corrected or kept in check by a variable-focal-length lens of the compositions shown in FIG. 1 to FIG. 3 relating to the first working example of this invention.

If done in this way, with a negative-positive-positive three-group variable-focal-length lens it is possible to make a picture-taking lens that can satisfactorily correct aberrations, can have a short minimum picture-taking distance and a wide picture-taking range, and is compact. And because the third group optical system, which formerly used an aspheric surface lens, can be made with a spherical lens, there is the further advantage of keeping down the cost of manufacturing it.

Second Working Example

FIG. 7, FIG. 8, and FIG. 9 show, respectively, the composition of the optical system of the variable-focal-length lens of the second working example (which is also the single-focal-length [sic; possibly a misprint for "short-focal-length"] end, that is, the wide-angle end, at the middle focal length, and at the long-focal-length end, that is, the telephoto end.

The variable-focal-length lens shown in FIG. 7 to FIG. 9 have first lens E1, second lens E2, third lens E3, fourth lens E4, fifth lens E5, sixth lens E6, seventh lens E7, eighth lens E8, diaphragm FA, and optical filter OF. In this case, the first lens E1 to the third lens E3 constitute the first group optical system G1, the fourth lens E4 to the seventh lens E7 constitute the second group optical system G2, the eighth lens E8 constitutes the third group optical system G3, they are supported by a support frame, etc. that is suitably shared by each group, and the groups move as one when zooming, etc. Also, the surface number of each optical surface is also shown in FIG. 7 to FIG. 9. And in order to avoid a more complicated explanation due to a larger number of digits for the reference symbols, the reference numbers for FIG. 7 to FIG. 9 are used independently for each working example, so even if common reference numbers are assigned in FIG. 7 to FIG. 9 and in FIG. 1 to FIG. 3, they do not necessarily represent a common composition with the first working example.

In FIG. 7 to FIG. 9, the components are arranged in order, from the side of the object such as the photo subject, first lens E1, second lens E2, third lens E3, diaphragm FA, fourth lens E4, fifth lens E5, sixth lens E6, seventh lens E7, eighth lens E8, and optical filter OF, and the image is formed on the back of the optical filter OF, which has various optical filtering functions.

The first lens E1 is a negative meniscus lens shaped convex on the object side, the second lens E2 is a negative meniscus lens shaped convex on the object side, and the third lens E3 is a positive lens consisting of a plano-convex lens that is convex

21

toward the object side; the first optical system G1, which consists of these lenses, first lens E1 to third lens E3, exhibits negative refractive power as a whole. The fourth lens E4 is a positive lens made up of a biconvex lens that is strongly convex toward the object side; in this case too, for example, it is a hybrid aspheric surface lens that is made up of glass lenses and forms an aspheric surface with a resin material formed on its object-side surface. The fifth lens E5 is a negative lens made up of a biconcave lens that is strongly concave toward the image side; these lenses, fourth lens E4 and fifth lens E5, are cemented into one, being affixed together so as to form a (two-ply) cemented lens.

The sixth lens E6 is a positive lens made up of a biconvex lens, and the seventh lens E7 is a positive lens made up of a biconvex lens that is strongly convex toward the image side. The second group optical system G2, which consists of this three-group four-lens composition of fourth lens E4 to seventh lens E7, exhibits positive refractive power as a whole. The diaphragm FA, which is arranged on the object side of the second group optical system G2, moves as one with the second group optical system G2. The eighth lens E8 is a positive meniscus lens formed to be convex on the object side, and the third group optical system G3, which is made up of only this eighth lens E8, exhibits positive refractive power.

In changing the focal length from the wide-angle end to the telephoto end, the first group optical system G1 moves toward the object side so as to describe a concave locus, and the second group optical system G2 moves monotonically toward the object. In focusing from infinity to a near-distance object, the third group optical system G3 is moved along the optical axis toward the object. The optical filter OF, which is made up of parallel flat plates positioned the most on the image side, is various filters such as a crystal low-pass filter or an infrared cutoff filter. As the focal length changes, the movement of the groups changes the spacing between the groups, specifically: the spacing D12 between the surface most on the image side of the first group optical system G1, that is, the image-side surface (surface number 6) of the third lens E3, and the object-side surface (surface number 7) of the diaphragm FA that is integral with the second group optical system G2; the spacing D23 between the surface most on the image side of the second group optical system G2, that is, the image-side surface (surface number 15) of the seventh lens E7, and the surface most on the object side of the third group optical system G3, that is, the object-side surface (surface number 16) of the eighth lens E8 and the spacing D3F between the surface most on the image side of the third group optical system G3, that is, the image-size surface (surface number 17) of the eighth lens E8, and the object-side surface (surface number 18) of the optical filter OF.

In this second working example, as the focal length changes from the wide-angle side to the telephoto side, other measurements change as well, including

- overall focal length: from 4.33 to 12.22 mm
- F number: from 2.64 to 4.46
- half face angle: from 40° to 16°.

The properties of each optical surface are as in the following table.

[Table 4] Optical properties

Surface	Radius of curvature	Spacing	Refractive index	Abbe number		
1	48.743	1.00	1.71300	53.94	1 st lens	1 st group optical
2	7.022	0.99	1.00000			

22

-continued

Surface	Radius of curvature	Spacing	Refractive index	Abbe number		
3	13.235	1.00	1.80610	40.74	2 nd lens	system
4*	4.906	1.70	1.00000			
5	9.973	2.41	1.76182	26.60	3 rd lens	
6	0.000	13.83	1.00000			
7	0.000	0.80	1.00000		diaphragm	
8*	6.052	0.02	1.50703	53.43	(resin)	2 nd group optical
9	5.692	3.12	1.72342	37.99	4 th lens	system
10	-29.737	1.93	1.84666	23.78	5 th lens	
11	5.657	0.32	1.00000			
12	14.148	1.95	1.48749	70.44	6 th lens	
13	-14.148	0.30	1.00000			
14	41.652	1.32	1.48749	70.44	7 th lens	
15	-18.843	1.50	1.00000			
16	10.509	1.89	1.51680	64.20	8 th lens	3 rd group optical system
17	58.182	2.14	1.00000			
18	0.000	0.48	1.54892	69.13	Filter	
19	0.000	0.34	1.54892	69.13		
20	0.000	0.50	1.50000	64.00		
21	0.000					

The optical surfaces of surfaces 4 and 8 whose surface number is marked with an asterisk (*) in Table 4 are aspheric surfaces, and the parameters of each aspheric surface in formula (3) are as in the following table.

[Table 5] Asphericities

Surface		4	8
Asphericity	A ₄	-1.17507E-03	-4.43095E-04
	A ₆	-3.05276E-05	-1.70593E-05
	A ₈	2.02661E-06	1.87848E-06
	A ₁₀	-3.84638E-07	-1.33481E-07
	A ₁₂	2.31751E-08	0.
	A ₁₄	-8.01568E-10	0.
	A ₁₆	1.52884E-11	0.
	A ₁₈	-2.98849E-13	0.

The spacing D12 between the first group optical system G1 and the diaphragm FA, which is integral with the second group optical system G2, the spacing D23 between the second group optical system G2 and the third group optical system G3, and the spacing D3F between the third group optical system G3 and the optical filter OF change as in the following table when the focal length changes.

[Table 6] Variable spacing

TABLE 6

Variable spacing			
Surfaces	Wide-angle end	Middle	Telephoto end
D12	13.54	5.63	1.20
D23	1.50	6.77	15.81
D3F	3.51	3.19	1.79

Also, the following are the numerical values of |(R1-R2)/(R1+R2)| in condition formula (1) and of |(D23wxf3)/fw²| in condition formula (2) referred to above in this second working example.

Condition formula numerical values:

- (1) formula = -0.694
- (2) formula = 1.96

Therefore the numerical values for the condition formulas of this invention referred to above in this second working example all lie within the range of the condition formulas.

FIG. 10 to FIG. 12 are aberration curve diagrams for the aberrations of the variable-focal-length lenses shown in FIG. 7 to FIG. 9 of the above second working example; FIG. 10 is an aberration curve diagram at the wide-angle end, FIG. 11 is an aberration curve diagram in the middle focal length, and FIG. 12 is an aberration curve diagram at the telephoto end.

According to these aberration curve diagrams in FIG. 10 to FIG. 12, it is clear that aberration is satisfactorily corrected or kept in check also by a variable-focal-length lens of the compositions shown in FIG. 7 to FIG. 9 relating to the second working example of this invention.

Third embodiment

Next, we describe, with reference to FIG. 13, a third embodiment of this invention that comprises a camera adopting as the picture-taking optical system a picture-taking lens unit made using as a zoom lens the variable-focal-length lens of this invention such as is shown in the above first and second working examples. FIG. 13 is a perspective view showing the appearance of the camera as seen from its rear side, which is the side of the photographer. Also, here we describe a camera, but in recent years products have appeared in which camera functions are built into a so-called PDA (personal data assistant), portable telephone, or other portable information terminal. Such portable information terminals, although they may look somewhat different, include essentially exactly the same functions and features as a camera, and one may adopt the variable-focal-length lens of this invention in such a portable information terminal.

As shown in FIG. 13, the camera has a picture-taking lens unit 101, a shutter button 102, a zoom button 103, an optical viewfinder 104, a liquid crystal display unit 105, a liquid crystal monitor 106, and a main switch 107.

The camera has the picture-taking lens unit 101, a CCD (charge-coupled device) imaging element, or other light-sensing element (not pictured) as an area sensor, and is constituted so that the image of the object to be imaged that is formed by the picture-taking lens unit 101, which is the picture-taking optical system, that is, the image of the photo subject, is read by the light-sensing element. Used as this picture-taking lens unit 101 is a variable-focal-length lens of this invention such as is described in the first and second working examples.

The output of the light-sensing element is processed by a signal processor (not pictured) that is controlled by a central processing unit (CPU) (not pictured) and is converted into digital image information. The image information, digitized by the signal processor, undergoes the prescribed image processing in an image processor (not pictured) that is likewise controlled by the central processing unit, then is recorded in a nonvolatile memory or other semiconductor memory (not pictured). In this case, the semiconductor memory may be a memory card that is mounted in a memory card slot, etc., or it may be a semiconductor memory that is built into the main body of the camera. The image being photographed can be displayed as an electronic viewfinder on the liquid crystal monitor 106, and images recorded in the semiconductor memory may also be displayed. Also, images recorded in the semiconductor memory can be transmitted to the outside via a communication card, etc. mounted in a communication card slot, etc.

The picture-taking lens unit 101 is constructed so that it is held within the body of the camera in retracted state when the camera is being carried around, and when the user operates the main switch 107 and turns on the power, the lens barrel is extended as pictured, and it protrudes from the body of the

camera. At this time, inside the lens barrel of the picture-taking lens unit, the optical system of the groups that constitute the variable-focal-length lens are arranged for example on the short-focus end, and by operating a zoom button 103, the arrangement of the group optical systems can be changed, changing the magnification to the long-focus end. Preferably, the optical viewfinder 104 also changes its magnification coupled to the change in the field angle of the picture-taking lens unit 101. In many cases, focusing is done by half-pressing the shutter button 102. In this case, focusing in the variable-focal-length lens made up of three groups, negative-positive-positive in this invention (the variable-focal-length lens defined in claim 1 to claim 5, or shown in the first and second working examples) can be done by moving the third group optical system G3. Pressing the shutter button 102 in all the way causes a picture to be taken, after which processing is done as described above.

As has already been stated, a variable-focal-length lens such as shown in the first and second working examples can be used as a picture-taking optical system in a camera or portable information terminal such as described above. Therefore it is possible to create a small-size camera or portable information terminal with high picture quality using light-sensing elements in the 3-5 megapixel class or more. In this case, with this portable information terminal one can make high-picture-quality images and transmit them to outside.

Effects of the Invention

As stated above, this invention makes it possible to provide—in a variable-focal-length lens that has a first group optical system having negative refractive power, a second group optical system having positive refractive power, and a third group optical system having positive refractive power arranged in that order from the object side, has on the object side of the second group optical system a diaphragm that moves as one with the second group optical system, and changes the focal length by changing the relative spacing of the group optical systems—a variable-focal-length lens that is small, has a wide field angle, and can have high picture quality, and in addition is low-cost and can focus by moving the third group optical system along the optical axis, as well as a lens unit, camera, and portable information terminal.

That is, according to the variable-focal-length lens of a first aspect of this invention, it is a variable-focal-length lens that has a first group optical system having negative refractive power, a second group optical system having positive refractive power, and a third group optical system having positive refractive power arranged in that order from the object side, has on the object side of the second group optical system a diaphragm that moves as one with the second group optical system, changes the focal length by changing the relative spacing of the group optical systems, and in order to focus moves the third group optical system along the optical axis; the first group optical system has a negative meniscus lens, a negative meniscus lens, and a positive lens arranged in that order from the object side, an aspheric surface being formed on at least one surface among the two negative meniscus lenses; the second group optical system has a cemented lens of a positive lens and a negative lens, a positive lens, and a positive lens arranged in that order from the object side, forming an aspheric surface on the surface on the object side of the positive lens that is most on the object side; and the third group optical system consists of a single positive lens that does not include an aspheric surface; and thereby in particular it can satisfactorily correct aberrations, has a

25

short minimum picture-taking distance and a wide picture-taking range, and can reduce aspheric surfaces, and have a low-cost, compact configuration.

Also, according to the variable-focal-length lens of a second aspect of this invention, it is a variable-focal-length lens that has a first group optical system having negative refractive power, a second group optical system having positive refractive power, and a third group optical system having positive refractive power arranged in that order from the object side, has on the object side of the second group optical system a diaphragm that moves as one with the second group optical system, changes the focal length by changing the relative spacing of the group optical systems, and in order to focus moves the third group optical system along the optical axis; the first group optical system has a negative meniscus lens, a negative meniscus lens, and a positive lens arranged in that order from the object side; the second group optical system has a cemented lens of a positive lens and a negative lens, a positive lens, and a positive lens arranged in that order from the object side; the third group optical system consists of a single positive lens; an aspheric surface is formed on at least one surface of the negative meniscus lenses in the first optical system and on the surface that is most on the object side in the second group optical system; and the third optical system is constituted with only a spherical lens; and thereby in particular it can satisfactorily correct aberrations, has a short minimum picture-taking distance and a wide picture-taking range, and can effectively adopt spherical surfaces and have a low-cost, compact configuration.

According to the variable-focal-length lens of a third aspect of this invention, it is a variable-focal-length lens of the first or second aspect of this invention, and by the positive lens of the third optical system being a positive meniscus lens, in particular it is easy to make corrections to the image surface.

According to the variable-focal-length lens of a fourth aspect of this invention, it is a variable-focal-length lens of the third aspect of this invention, and by satisfying the condition formula:

$$-0.75 < |(R1-R2)/(R1+R2)| < -0.65 \quad (1)$$

where R1 is the radius of curvature of the object-side surface of the positive lens of the third group optical system, and R2 is the radius of curvature of the image-side surface of the positive lens of the third group optical system, in particular better correction is possible.

According to the variable-focal-length lens of a fifth aspect of this invention, it is a variable-focal-length lens of any of the first to fourth aspect of this invention, and by satisfying the condition formula:

$$1.5 < |(D23w \times f3)/fw^2| < 2.5 \quad (2)$$

where D23w is the distance between the second group optical system and the third group optical system at the wide-angle end, fw is the focal length of the entire system at the wide-angle end, and f3 is the focal length of the third group optical system, in particular the minimum picture-taking distance can be shortened while minimizing the increase in overall length, and distortion aberration and other aberrations can be satisfactorily corrected.

According to the variable-focal-length lens of a sixth aspect of this invention, by a variable-focal-length lens of any of the first to fifth aspect of this invention, in particular aberrations can be corrected, the minimum picture-taking distance can be made short and the picture-taking range can be made wide, and a contact configuration can be made at low cost.

26

According to the camera of a seventh aspect of this invention, by including as its picture-taking optical system a variable-focal-length lens of any of the first to fifth aspect of this invention, it is possible to satisfactorily correct aberrations, have a short minimum picture-taking distance and a wide picture-taking range, and have a compact configuration at low cost.

According to the portable information terminal of an eighth aspect of this invention, by including as the picture-taking optical system of its camera function unit a variable-focal-length lens of any of the first to fifth aspect of this invention, in particular it is possible to satisfactorily correct aberrations, have a short minimum picture-taking distance and a wide picture-taking range, and have a compact configuration at low cost.

What is claimed is:

1. A variable focal length lens comprising:

a first group optical system having a negative refracting power, a second group optical system having a positive refracting power, and a third group optical system having a positive refracting power, wherein the first through the third group optical systems are sequentially arranged from an object side; and

a stop provided on the object side of the second group optical system and that moves integrally with the second group optical system, wherein

a focal length is changed by changing distances between the first through the third group optical systems and when performing focusing the third group optical system is moved along an optical axis,

the first group optical system includes a negative meniscus lens, a negative meniscus lens, and a positive lens those are sequentially arranged from the object side, at least one surface of the two negative meniscus lenses being an aspherical surface,

the second group optical system includes a cemented lens of a positive lens and a negative lens, a positive lens, and a positive lens those are sequentially arranged from the object side, a surface on the object side of the positive lens on the most object side being an aspherical surface, and

the third group optical system includes one positive lens not including an aspherical surface.

2. The variable focal length lens according to claim 1, wherein the positive lens of the third group optical system is a positive meniscus lens.

3. The variable focal length lens according to claim 2, wherein when R1 is a radius of curvature a surface on an object side of the positive lens of the third group optical system, and R2 is a radius of curvature of a surface on an image side of the positive lens of the third group optical system, then the relation

$$-0.75 < \{(R1-R2)/(R1+R2)\} < -0.65$$

holds true.

4. The variable focal length lens according to claim 1, wherein when D23w is a distance between the second group optical system and the third group optical system at the wide-angle end, fw is a focal length of all the systems at the wide-angle end, and f3 is a focal length of the third group optical system, then the relation

$$1.5 < \{(D23w \times f3)/fw^2\} < 2.5$$

holds true.

5. A variable focal length lens comprising:

a first group optical system having a negative refracting power, a second group optical system having a positive

27

refracting power, and a third group optical system having a positive refracting power, wherein the first through the third group optical systems are sequentially arranged from an object side; and

a stop provided on the object side of the second group optical system and that moves integrally with the second group optical system, wherein

a focal length is changed by changing relative distances between the first through the third group optical systems and when performing focusing the third group optical system is moved along an optical axis,

the first group optical system includes a negative meniscus lens, a negative meniscus lens, and a positive lens those are sequentially arranged from the object side,

the second group optical system includes a cemented lens of a positive lens and a negative lens, a positive lens, and a positive lens those are sequentially arranged from the object side,

the third group optical system includes one positive lens, at least one surface of the negative meniscus lens in the first group optical system and a surface on the most object side in the second group optical system being aspherical surfaces, and

the third group optical system includes only a spherical lens.

6. The variable focal length lens according to claim 5, wherein the positive lens of the third group optical system is a positive meniscus lens.

7. The variable focal length lens according to claim 6, wherein

when R1 is a radius of curvature a surface on an object side of the positive lens of the third group optical system, and R2 is a radius of curvature of a surface on an image side of the positive lens of the third group optical system, then the relation

$$-0.75 < \{(R1 - R2) / (R1 + R2)\} < -0.65$$

holds true.

8. The variable focal length lens according to claim 5, wherein

when D23w is a distance between the second group optical system and the third group optical system at the wide-angle end, fw is a focal length of all the systems at the wide-angle end, and f3 is a focal length of the third group optical system, then the relation

$$1.5 < \{(D23w \times f3) / fw^2\} < 2.5$$

holds true.

9. A photographing lens unit comprising a variable focal length lens as an optical system, the variable focal length lens including

a first group optical system having a negative refracting power, a second group optical system having a positive refracting power, and a third group optical system having a positive refracting power, wherein the first through the third group optical systems are sequentially arranged from an object side; and

a stop provided on the object side of the second group optical system and that moves integrally with the second group optical system, wherein

a focal length is changed by changing distances between the first through the third group optical systems and when performing focusing the third group optical system is moved along an optical axis,

the first group optical system includes a negative meniscus lens, a negative meniscus lens, and a positive lens those

28

are sequentially arranged from the object side, at least one surface of the two negative meniscus lenses being an aspherical surface,

the second group optical system includes a cemented lens of a positive lens and a negative lens, a positive lens, and a positive lens those are sequentially arranged from the object side, a surface on the object side of the positive lens on the most object side being an aspherical surface, and

the third group optical system includes one positive lens not including an aspherical surface.

10. A photographing lens unit comprising a variable focal length lens as an optical system, the variable focal length lens including

a first group optical system having a negative refracting power, a second group optical system having a positive refracting power, and a third group optical system having a positive refracting power, wherein the first through the third group optical systems are sequentially arranged from an object side; and

a stop provided on the object side of the second group optical system and that moves integrally with the second group optical system, wherein

a focal length is changed by changing relative distances between the first through the third group optical systems and when performing focusing the third group optical system is moved along an optical axis,

the first group optical system includes a negative meniscus lens, a negative meniscus lens, and a positive lens those are sequentially arranged from the object side,

the second group optical system includes a cemented lens of a positive lens and a negative lens, a positive lens, and a positive lens those are sequentially arranged from the object side,

the third group optical system includes one positive lens, at least one surface of the negative meniscus lens in the first group optical system and a surface on the most object side in the second group optical system being aspherical surfaces, and

the third group optical system includes only a spherical lens.

11. A camera comprising a variable focal length lens as a photographing optical system, the variable focal length lens including

a first group optical system having a negative refracting power, a second group optical system having a positive refracting power, and a third group optical system having a positive refracting power, wherein the first through the third group optical systems are sequentially arranged from an object side; and

a stop provided on the object side of the second group optical system and that moves integrally with the second group optical system, wherein

a focal length is changed by changing distances between the first through the third group optical systems and when performing focusing the third group optical system is moved along an optical axis,

the first group optical system includes a negative meniscus lens, a negative meniscus lens, and a positive lens those are sequentially arranged from the object side, at least one surface of the two negative meniscus lenses being an aspherical surface,

the second group optical system includes a cemented lens of a positive lens and a negative lens, a positive lens, and a positive lens those are sequentially arranged from the

29

object side, a surface on the object side of the positive lens on the most object side being an aspherical surface, and

the third group optical system includes one positive lens not including an aspherical surface.

12. A camera comprising a variable focal length lens as a photographing optical system, the variable focal length lens including

a first group optical system having a negative refracting power, a second group optical system having a positive refracting power, and a third group optical system having a positive refracting power, wherein the first through the third group optical systems are sequentially arranged from an object side; and

a stop provided on the object side of the second group optical system and that moves integrally with the second group optical system, wherein

a focal length is changed by changing relative distances between the first through the third group optical systems and when performing focusing the third group optical system is moved along an optical axis,

the first group optical system includes a negative meniscus lens, a negative meniscus lens, and a positive lens those are sequentially arranged from the object side,

the second group optical system includes a cemented lens of a positive lens and a negative lens, a positive lens, and a positive lens those are sequentially arranged from the object side,

the third group optical system includes one positive lens, at least one surface of the negative meniscus lens in the first group optical system and a surface on the most object side in the second group optical system being aspherical surfaces, and

the third group optical system includes only a spherical lens.

13. A portable information terminal device comprising a variable focal length lens as a photographing optical system of a camera function unit, the variable focal length lens including

a first group optical system having a negative refracting power, a second group optical system having a positive refracting power, and a third group optical system having a positive refracting power, wherein the first through the third group optical systems are sequentially arranged from an object side; and

a stop provided on the object side of the second group optical system and that moves integrally with the second group optical system, wherein

30

a focal length is changed by changing distances between the first through the third group optical systems and when performing focusing the third group optical system is moved along an optical axis,

the first group optical system includes a negative meniscus lens, a negative meniscus lens, and a positive lens those are sequentially arranged from the object side, at least one surface of the two negative meniscus lenses being an aspherical surface,

the second group optical system includes a cemented lens of a positive lens and a negative lens, a positive lens, and a positive lens those are sequentially arranged from the object side, a surface on the object side of the positive lens on the most object side being an aspherical surface, and

the third group optical system includes one positive lens not including an aspherical surface.

14. A portable information terminal device comprising a variable focal length lens as a photographing optical system of a camera function unit, the variable focal length lens including

a first group optical system having a negative refracting power, a second group optical system having a positive refracting power, and a third group optical system having a positive refracting power, wherein the first through the third group optical systems are sequentially arranged from an object side; and

a stop provided on the object side of the second group optical system and that moves integrally with the second group optical system, wherein

a focal length is changed by changing relative distances between the first through the third group optical systems and when performing focusing the third group optical system is moved along an optical axis,

the first group optical system includes a negative meniscus lens, a negative meniscus lens, and a positive lens those are sequentially arranged from the object side,

the second group optical system includes a cemented lens of a positive lens and a negative lens, a positive lens, and a positive lens those are sequentially arranged from the object side,

the third group optical system includes one positive lens, at least one surface of the negative meniscus lens in the first group optical system and a surface on the most object side in the second group optical system being aspherical surfaces, and

the third group optical system includes only a spherical lens.

* * * * *