



(86) Date de dépôt PCT/PCT Filing Date: 2016/01/15  
 (87) Date publication PCT/PCT Publication Date: 2016/07/21  
 (85) Entrée phase nationale/National Entry: 2017/07/05  
 (86) N° demande PCT/PCT Application No.: US 2016/013703  
 (87) N° publication PCT/PCT Publication No.: 2016/115523  
 (30) Priorité/Priority: 2015/01/15 (US62/103,928)

(51) Cl.Int./Int.Cl. *A47J 37/04* (2006.01),  
*F24C 15/18* (2006.01)  
 (71) Demandeur/Applicant:  
 W.C. BRADLEY CO., US  
 (72) Inventeur/Inventor:  
 AHMED, MALLIK, US  
 (74) Agent: MACRAE & CO.

(54) Titre : SYSTEME ET PROCEDE D'AMELIORATION DE LA COMBUSTION DU CHARBON DE BOIS POUR LA CUISSON

(54) Title: SYSTEM AND METHOD FOR IMPROVING CHARCOAL COMBUSTION FOR COOKING

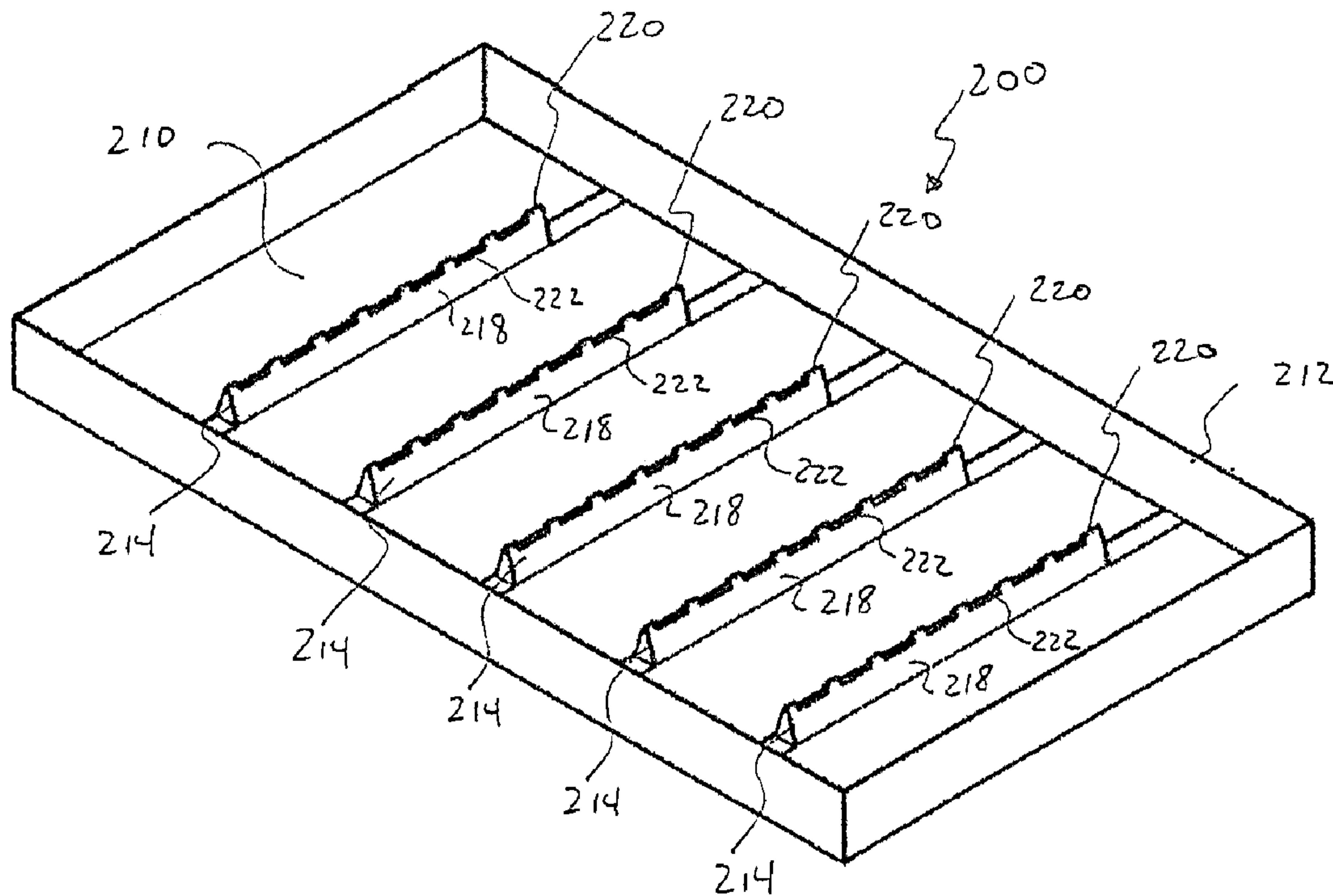

Fig. 2C

(57) Abrégé/Abstract:

A charcoal pan includes a supporting surface for supporting a quantity of charcoal beneath a cooking grate, and a plurality of diffusers that transport air from underneath the supporting surface to an area above at least a portion of the quantity of charcoal.

(12) INTERNATIONAL APPLICATION PUBLISHED UNDER THE PATENT COOPERATION TREATY (PCT)

(19) World Intellectual Property  
Organization  
International Bureau(10) International Publication Number  
**WO 2016/115523 A1**(43) International Publication Date  
21 July 2016 (21.07.2016)

## (51) International Patent Classification:

A47J 37/04 (2006.01) F24C 15/18 (2006.01)

## (21) International Application Number:

PCT/US2016/013703

## (22) International Filing Date:

15 January 2016 (15.01.2016)

## (25) Filing Language:

English

## (26) Publication Language:

English

## (30) Priority Data:

62/103,928 15 January 2015 (15.01.2015) US

(71) Applicant: W.C. BRADLEY CO. [US/US]; 1017 Front Avenue, Columbus, GA 31904 (US).

(72) Inventor: AHMED, Mallik; 1517 Ridge Creek Way, Columbus, GA 31904 (US).

(74) Agent: WOODRAL, David, G.; Fellers, Snider, Blankenship, Bailey &amp; Tippens, P.C., 321 South Boston, Suite 800, Tulsa, OK 74103-3318 (US).

(81) Designated States (unless otherwise indicated, for every kind of national protection available): AE, AG, AL, AM,

AO, AT, AU, AZ, BA, BB, BG, BH, BN, BR, BW, BY, BZ, CA, CH, CL, CN, CO, CR, CU, CZ, DE, DK, DM, DO, DZ, EC, EE, EG, ES, FI, GB, GD, GE, GH, GM, GT, HN, HR, HU, ID, IL, IN, IR, IS, JP, KE, KG, KN, KP, KR, KZ, LA, LC, LK, LR, LS, LU, LY, MA, MD, ME, MG, MK, MN, MW, MX, MY, MZ, NA, NG, NI, NO, NZ, OM, PA, PE, PG, PH, PL, PT, QA, RO, RS, RU, RW, SA, SC, SD, SE, SG, SK, SL, SM, ST, SV, SY, TH, TJ, TM, TN, TR, TT, TZ, UA, UG, US, UZ, VC, VN, ZA, ZM, ZW.

(84) Designated States (unless otherwise indicated, for every kind of regional protection available): ARIPO (BW, GH, GM, KE, LR, LS, MW, MZ, NA, RW, SD, SL, ST, SZ, TZ, UG, ZM, ZW), Eurasian (AM, AZ, BY, KG, KZ, RU, TJ, TM), European (AL, AT, BE, BG, CH, CY, CZ, DE, DK, EE, ES, FI, FR, GB, GR, HR, HU, IE, IS, IT, LT, LU, LV, MC, MK, MT, NL, NO, PL, PT, RO, RS, SE, SI, SK, SM, TR), OAPI (BF, BJ, CF, CG, CI, CM, GA, GN, GQ, GW, KM, ML, MR, NE, SN, TD, TG).

## Published:

— with international search report (Art. 21(3))

(54) Title: SYSTEM AND METHOD FOR IMPROVING CHARCOAL COMBUSTION FOR COOKING

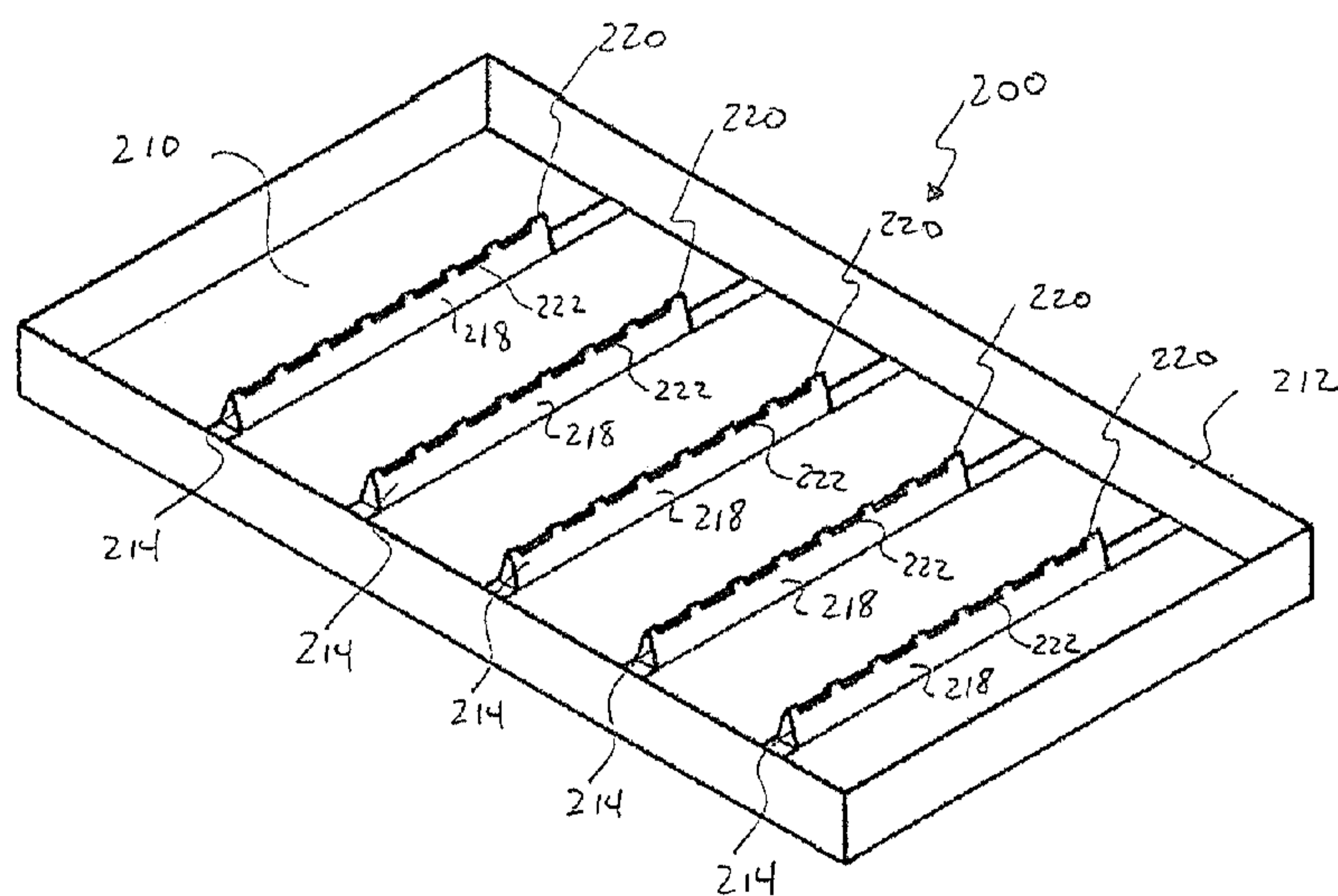

Fig. 2C

(57) Abstract: A charcoal pan includes a supporting surface for supporting a quantity of charcoal beneath a cooking grate, and a plurality of diffusers that transport air from underneath the supporting surface to an area above at least a portion of the quantity of charcoal.

WO 2016/115523 A1

## SYSTEM AND METHOD FOR IMPROVING CHARCOAL COMBUSTION FOR COOKING

### CROSS-REFERENCE TO RELATED CASES

This application claims the benefit of U.S. provisional patent application Serial No. 62/103,928 filed on January 15, 2015, and incorporates such provisional application by reference into this disclosure as if fully set out at this point.

5

### FIELD OF THE INVENTION

This disclosure relates to cooking with solid fuels in general and, more particularly, to an improved device and method for combustion of solid cooking fuels.

### BACKGROUND OF THE INVENTION

10 Portable charcoal grills for cooking food outdoors have been used or manufactured since at least 1948. Since this time construction of such grills has remained largely unchanged with respect to the physical relationship between the charcoal fuel, the supply of air for combustion, and the placement of food. An example grill can be seen in US Patent No. 4,416,248 to Schlosser which places in a bowl shaped space a set of bars on which charcoal is placed, called a fire grate. An air opening is  
15 provided below the fire grate. And another set of bars forming a grate above the fire grate on which food is placed is called the cooking grate. With variations as to the shape of the space in which these elements are placed (which can be rectangular rather than circular) this approach has been widely used.

In the case of the approach where air is admitted to the charcoal bed from below,  
20 the charcoal burns from the bottom of the briquette (or fragment) to the top. This means that during most of the burning life of the piece of charcoal half or more of the released radiant energy is directed downward and away from the food being cooked. Further, with combustion air provided from the bottom, a relatively hotter area of the fire will generate a flue effect that draws in more air for combustion making that area even hotter.  
25 Therefore, there is a tendency for heat to become more and more uneven as the fire develops. The nature of the action is well described in *Modernist Cuisine*, Vol. 2 by Myhrvold, et al., Chapter 7, pp. 14-17.

When air is entrained from below the subsequent thermal draft develops locally high air velocities around the pieces of burning charcoal (like a bellows) with consequently developed small flames. These flames ignite the fat that extracted from cooking food causing flare-ups with undesirable sustained flame contact with the food.

5 Because of these flare-ups the charcoal bed is located spaced substantially far apart from the cooking grate. This results in less efficient cooking with limited sear marks, and requires continuous attention in the cooking process. Further, flare-up conditions can carry ash from charcoal to food.

What is needed is a system and method for addressing the above and related

10 concerns.

### SUMMARY OF THE INVENTION

The invention of the present disclosure, in one aspect thereof, comprises a charcoal pan for use within a grill. The charcoal pan includes a supporting surface for supporting a quantity of charcoal beneath a cooking grate, and a plurality of diffusers that

15 transport air from underneath the supporting surface to an area above at least a portion of the quantity of charcoal.

In some embodiments, the plurality of air diffusers comprise a plurality of parallel peaked structures rising from the supporting surface and having at least one air gap facing upward from the peaks thereof. The air gaps may be at least .5 inches above the

20 supporting surface and the plurality of parallel peaked structures may be spaced apart from 4 inches to 5 inches.

The the plurality of air diffusers may comprise a plurality of parallel peaked structures rising from the supporting surface, each peaked structure having at least one air opening defined in a sidewall below the peak. The supporting surface may bounded

25 by a boundary wall defining at least one air opening therein, the at least one air opening being situated above the supporting surface. In some embodiments, there is a slidable closure on each of the plurality of air diffusers. Each slidable closure defines an opening corresponding with the at least one air opening of the respective air diffuser and is selectively slidable to alter a degree of overlap between the respective adjacent openings

30 to alter airflow volume of the diffuser.

In another embodiment, the plurality of air diffusers comprises a plurality of open-topped cones rising from the supporting surface. The open topped cones may each have a cover that is spaced apart from the top of the cone to define an air gap between the cover and the cone.

5 The invention of the present disclosure, in another aspect thereof, comprises a charcoal pan having a flat support surface bounded by an outer wall, and a plurality of air conduits defining air passageways from below the flat support surface and terminating a predetermined distance above the flat support surface.

10 In some embodiments, the outer wall defines a plurality of air openings around a periphery of the flat support surface. The plurality of air conduits may comprises a plurality of parallel spaced apart peaked structures rising from the flat support surface and having an air opening on the peaks thereof. In another embodiment the plurality of air conduits comprises a plurality of double walled structures rising from the flat support surface and joining at a peak. The double walled structures may define air openings in  
15 the walls. A slidable closure may selectively partially or completely cover the air openings in the walls.

In another embodiment, the plurality of air conduits comprises a plurality of hollow and opened topped conic structures rising from the flat support surface. A covering may be spaced apart from the top of each of the open topped conic structures.

20 The invention of the present disclosure, in another embodiment thereof, comprises a method of providing a flat support surface bounded around the outside to contain a quantity of charcoal below a cooking grate, and forming a plurality of air passageways allowing air flow from below the flat support surface to a predetermined level above the flat support surface.

25 The method may include forming the plurality of air passageways in a repeating equidistantly spaced pattern on the flat support surface. An adjustable closure may be provided on the plurality of air passageways, the adjustable closure having at least selectable positions for complete opening of the air passageways and partial closure of the air passageways. In another embodiment, the method includes providing a spaced  
30 apart cover for each of the plurality of air passageways.

## BRIEF DESCRIPTION OF THE DRAWINGS

Figure 1 is a perspective view of an exterior of a cooking grill according to aspects of the present disclosure.

Figure 2A is an inferior perspective cutaway view of the grill of Figure 1.

5 Figure 2B is an inferior perspective cutaway view of the grill of Figure 1 rotated approximately 60 degrees from that of Fig. 2.

Figure 2C is a perspective view of a charcoal pan for use with the grill of Figures 1-2B.

Figure 2D is a front cutaway view of the grill of Figure 1.

10 Figure 2E is a side cutaway view of the grill of Figure 1.

Figure 3A is an inferior perspective cutaway view of a cooking grill according to aspects of the present disclosure.

Figure 3B is an inferior perspective cutaway view of the grill of Figure 3A rotated approximately 60 degrees.

15 Figure 3C is a perspective view of a charcoal pan for use with the grill of Figures 3A-3B.

Figure 3D is a front cutaway view of the grill of Figure 3A.

Figure 3E is a side cutaway view of the grill of Figure 3A.

20 Figure 4A is an inferior perspective cutaway view of a cooking grill according to aspects of the present disclosure.

Figure 4B is an inferior perspective cutaway view of the grill of Figure 4A rotated approximately 60 degrees.

Figure 4C is a perspective view of a charcoal pan for use with the grill of Figures 4A-4B.

25 Figure 4D is a perspective view of the charcoal pan of Figure 4C shown with air diffusers closed.

Figure 4E is a front cutaway view of the grill of Figure 4A.

Figure 4F is a side cutaway view of the grill of Figure 4A.

30 Figure 5A is an inferior perspective cutaway view of a cooking grill according to aspects of the present disclosure.

Figure 5B is an inferior perspective cutaway view of the grill of Figure 5A rotated approximately 60 degrees.

Figure 5C is a perspective view of a charcoal pan for use with the grill of Figures 5A-5B.

5 Figure 5D is a front cutaway view of the grill of Figure 5A.

Figure 5E is a side cutaway view of the grill of Figure 5A.

Figure 6A is an inferior perspective cutaway view of a cooking grill according to aspects of the present disclosure.

10 Figure 6B is an inferior perspective cutaway view of the grill of Figure 6A rotated approximately 60 degrees.

Figure 6C is a perspective view of a charcoal pan for use with the grill of Figures 6A-6B.

Figure 6D is a front cutaway view of the grill of Figure 6A.

Figure 6E is a side cutaway view of the grill of Figure 6A.

## 15 DETAILED DESCRIPTION OF THE PREFERRED EMBODIMENTS

Referring now to Figure 1, a perspective view of the exterior of a cooking grill **100** is shown. The grill **100** may be a barbecue grill designed for the use of charcoal only, or may be a hybrid gas/charcoal product where a gas burner is used to ignite the charcoal. The grill **100** may also be a convertible device where an interior charcoal  
20 container can be removed and the grill **100** be used as a gas grill.

The grill **100** may be mounted on legs **102** but could also be mounted on a wheeled cart or other location. A lower portion is generally configured as a fire box **104**. The firebox **104** may provide a combustion air intake **106**. The intake **106** is not limited to the location or configuration shown, but may be generally below a level of the internal  
25 charcoal bed. An openable lid **108** may be removably fitted to the fire box **104**. In some embodiments, the lid **108** is hinged to the fire box **104**. The lid **108** may provide an exhaust gas outlet **110**. The outlet **110** is not limited to the location or configuration shown. It should also be understood that there may be multiple intakes and outlets in various locations on the firebox **104** and lid **108**, respectively. In some embodiments, a  
30 gap between the firebox **104** and lid **108** may function as an exhaust outlet.

Referring now to Figure 2A, an inferior perspective cutaway view of the grill **100** of Figure 1 according to aspects of the present disclosure is shown. Figure 2B provides a second inferior perspective cutaway view rotated approximately 60 degrees from Figure A. Figure 2C provides a perspective view of the charcoal pan **200** for use with the grill **100**. Figure 6D is a front cutaway view of the grill **100** of Figure 1 and Figure 6E is a side cutaway view of the grill **100** of Figure 1. Reference to these figures together illustrates a grill **100** with a charcoal pan **200** that may be placed in the firebox **104** of the grill **100**. The charcoal pan **200** may be placed below a food grate **190** and support a bed of charcoal **202**. The charcoal bed **202** may comprise lump charcoal or charcoal briquettes.

The charcoal pan **200** provides a solid and generally planar or flat support surface **210**. The support surface **210** may be rectilinear in shape or otherwise configured to fit within the firebox **104**. It will be appreciated that the charcoal pan **200** may be adapted for grills with a rounded or oval firebox by taking on a round shape itself. The support surface **210** may be bounded around an outer perimeter by a wall **212**. The wall **212** may have a height sufficient for aiding in retention of the charcoal bed **202**.

Proceeding upwardly from the support surface **210** are a plurality of diffusers **214** that provide a passageway or conduit **216** (best seen in inferior views of Figures 2A and 2B and cutaway view of Figure 2D) for air to pass from below the support surface **210** and above the charcoal bed **202**. The diffusers **214** comprise a pair of upwardly angled walls **218** joining at an apex **220** to form a peaked structure. The apex **220** may be interrupted with a plurality of air gaps **222**. In another embodiment, a single air gap occupies what would otherwise be the joiner or apex between the angled walls **218**.

The air gaps **222** are elevated into the charcoal bed **202** in order to provide air to the side or tops of the individual lumps or briquettes in the charcoal bed **202**. This allows the charcoal bed to burn from the top rather than the bottom. Thus, more of the radiant heat is directed upward to the food grate **190** where it can be utilized for cooking. Providing air at or nearer the top of the charcoal bed **202** also reduces flying ash rising to contaminate the food. The heat generated by the burning charcoal bed **202** will provide ample drawing effect of air through the conduits **216** such that no additional motivation is needed.

As best seen in Figure 2C, the diffusers **214** may be arranged “front to back” on the support surface **210** and in parallel with one another. In another embodiment, the diffusers **214** are arranged side to side in parallel. In further embodiments, the diffusers **214** may form squares or other patterns. In cases where the diffusers **214** are parallel, they may be placed on the support surface such that they are from about 4 inches to about 5 inches apart (between adjacent walls **218** of adjacent diffusers **214**). This spacing allows for two standard size charcoal briquettes to fit between the diffusers (as seen in Figure 2D). The height reached by the upwardly angled walls **218** relative to the support surface **210** before terminating or opening into gaps **222** may be from about .5 inches to about 1 inch. A one inch height of the air gaps **222** will allow the air gaps **222** to be at or above the top of a standard charcoal briquette such that air is provided above at least the first layer of briquettes in the charcoal bed **202**. In other embodiments the air gaps **222** are even higher to allow larger or deeper charcoal beds. The air gaps **222** may also be lower but at the risk of diminishing performance of the charcoal pan **200** insofar as keeping charcoal briquettes burning from the top and reducing flying ash.

Figure 2D illustrates exemplary air flow through and around the charcoal bed **202** on the pan **200**. Air is drawn in through intakes **106** where it arrives at the bottom of the pan **200** to be drawn upward through air diffusers **214** to feed the burning charcoal bed **202** from above rather than below. Hot gases rise from the charcoal bed **202** and are used for cooking on the cooking grate **190** before being exhausted via outlets **110**. The cooking grate **190** can be much closer to the charcoal bed **202** than with previous systems since the charcoal bed **202** burns from the top down. This allows better heat transfer and cooking characteristics, while at the same time reducing flying ash since air is not flowing upward through the burning charcoal bed **202**.

Referring now to Figure 3A, an inferior perspective cutaway view of a cooking grill **300** according to aspects of the present disclosure is shown. Figure 3B is an inferior perspective cutaway view of the grill **300** of Figure 3A rotated approximately 60 degrees. Figure 3C is a perspective view of a charcoal pan **301** for use with the grill **300** of Figures 3A-3B. Figure 3D is a front cutaway view of the grill **300**, while Figure 3E is a side cutaway view of the grill **300**. Taken together, these drawings illustrate an

embodiment of a grill **300** that, like the grill **100** previously described, provides enhanced burning characteristics when cooking with solid fuels (e.g., charcoal).

The exterior of the grill **300** is substantially similar to that of the grill **100** of Figure 1. The charcoal pan **301** is adaptable to a wide variety of shapes and configurations in order to fit within the applicable firebox. The illustrated embodiment of the charcoal pan **301** (e.g., Figure 3C) provides a rectilinear shape such as is be suitable for a firebox having a width greater than its length. The charcoal pan **301** is built upon a substantially flat and planar support surface **310** for supporting a bed of charcoal **202**. A wall **312** may be formed around the perimeter of the support surface **310** to aid in retention of the briquettes forming the charcoal bed **202**. The wall **312** provides a series of openings or apertures **324** that provide airflow to the top of the charcoal bed **202**.

Rising from the support surface **310** is a plurality of air diffusers **314**. The diffusers **314** may comprise a pair of sidewalls **318** angled upward from the support surface to form a peaked structure having an apex **320**. In some embodiments, the walls **318** may be flat topped or rounded rather than joining in a peak. Below the apex **320** on each of the sidewalls **318** is a series of opening or apertures **322**. The diffusers **314** each defines an air passageway **316** (best seen in the inferior views of Figures 3A-3B) providing air flow to and out of the openings **322**.

The size and spacing of the apertures **322**, **324** may vary. Generally, they may be sized and spaced so as to provide airflow while retaining the charcoal. Although briquettes would be unlikely to escape or spill through an aperture **322**, **324**, even if piled very high, lump charcoal has a much more random distribution of sizes, which may mean use of smaller apertures **322**, **324** is in order. Smaller apertures result in less air flow per individual aperture so the spacing may be decreased (e.g., the total number of apertures increased) to offset this effect. In one embodiment the apertures may be about .25 inches in diameter with spacing from .25 inches to .5 inches. In other embodiments the apertures may range from as small as about .125 inches to as large as about .5 inches, with spacing scaled accordingly based on performance.

As best seen in Figure 3D, the apertures **322** in the diffusers **314** and the apertures **324** in the wall **312** are defined at a height sufficiently above the supporting surface **310**

so as to provide air flow at least to the top of the first layer of charcoal briquettes of the charcoal bed **202**. In one embodiment, these apertures **322**, **324** are located about .5 inches to about 1 inch above the support surface **310**. A 1 inch height allows air flow to reach the top of a layer of charcoal briquettes from most or all manufacturers. The various embodiments of the present disclosure may also be used with lump charcoal although with slightly less control over where in the layers of the charcoal bed the air reaches given the more random size distribution of lump charcoal.

Spacing between the diffusers **314** (from adjacent walls **318** of adjacent diffusers **314**) may be from about 4 inches to about 5 inches, which allows for two standard size briquettes to be placed between adjacent diffusers. The spacing between diffusers **314** and the perimeter wall **312** may also be from about 4 to about 5 inches for the same charcoal briquette accommodation.

As best seen in Figure 3C, the diffusers **314** may be arranged on the support surface **310** aligned front to back in a parallel array. Diffusers **314** may also be aligned side to side and parallel in an array. Diffusers **314** may also be arranged in other shapes provided the 4 to 5 inch spacing is observed.

Figure 3D illustrates an exemplary manner of airflow through and around the charcoal pan **301**. Air entering through intakes **106** is drawn through the support surface via air conduits **316** terminating in apertures **322** at or near at least the first layer of the charcoal bed **202**. Air may also flow in over the burning charcoal bed **202** through apertures **324** in the perimeter wall **312**. Again, this allows the charcoal bed **202** to burn from the top down increasing heat output and decreasing flying ash.

Referring now to Figure 4A, is an inferior perspective cutaway view of a cooking grill **400** according to aspects of the present disclosure is shown. Figure 4B is an inferior perspective cutaway view of the grill **400** of Figure 4A rotated approximately 60 degrees. Figure 4C is a perspective view of a charcoal pan **401** for use with the grill of Figures 4A-4B. Figure 4D is a perspective view of the charcoal pan **400** of Figure 4C shown with air diffusers **414** closed. Figure 4E is a front cutaway view of the grill **400** while Figure 4F is a side cutaway view of the grill **400**.

The exterior of the grill **400** is substantially similar to those previously described. The layout of the charcoal pan **401** is somewhat similar as well. A support surface **410**

for resting a bed of charcoal **202** is provided and may be bounded by a perimeter wall **412**. The overall shape of the pan **401** may be rectilinear or rounded to depend upon the shape of the firebox in which it is employed.

A plurality of diffusers **414** is arrayed on the support surface **410**. As shown in  
5 Figures 4C-4D, the diffusers are aligned front to back with respect to the charcoal pan **401** but other configurations are possible as previously described. The diffusers **414** are adjustable via a sliding adjustment mechanism **450**. As best seen in Figures 4A-4B the diffusers **414** comprise a pair of upwardly angled walls **418**. The walls **418** may form a peaked structure with an apex **420**. The walls **418** each define a plurality of apertures **422**  
10 that are spaced apart from (e.g., above) the support surface **410**. The walls **418** thus define an air conduit **416** allowing air to pass from below the support surface **410** to an area at or above a charcoal bed **202** resting on the support surface **410**.

Best seen with reference to Figures 4C-4D, the sliding adjusters **450** may be provided with a handle **452** allowing them to be moved back and forth on the walls **418**.  
15 In some embodiments, some or all of the handles **452** are linked together to allow for easy and consistent adjustments. The adjusters **450** may overlap the walls **418** and have a similar shape so as to allow the peaked structure of the walls **418** below to nest in the adjuster **450**. Therefore the adjusters **450** may also form a peaked structure with walls **458** joining at an apex **470**. The walls **458** may define a plurality of apertures **472**.  
20 These may be of similar size, shape, and spacing as the apertures **422** in the walls **418**. The adjusters **450** may be moved such that the apertures **472** align with the apertures **422** of the walls **418** below. In Figure 4C the air conduit **416** is completely open and functions to provide full air flow to the charcoal bed **202**. On the other hand, as shown in Figure 4D, the adjusters **450** may be slid along the respective walls **418** such that there is  
25 no overlap between apertures **422** and apertures **472**. Perhaps of greater use in controlling rate of burn of the charcoal bed **202**, the diffusers **418** may be partially opened by moving the adjusters **450** such that there is partial overlap between the apertures **422**, **472** such that an intermediate airflow is achieved.

Figure 4E illustrates an exemplary airflow within the grill **400** when the adjusters  
30 are open. Here again, air from the intakes **106** is allowed to flow upward through the air conduits **416** and to the top of at least the first layer of the charcoal bed **202**. The

apertures **422**, **472** may be arranged vertically to be from about .5 inches to about 1 inch above the support surface to accommodate standard charcoal briquettes. The diffusers **414** may be spaced apart from one another about 4 inches to about 5 inches (from adjacent walls **418** of adjacent diffusers **414**) to accommodate the width of at least two standard sized charcoal briquettes. In this and other embodiments, the spacing between the end diffusers **414** and the wall **412** may be similar to the inter diffuser spacing.

Referring now to Figure 5A, an inferior perspective cutaway view of a cooking grill **500** according to aspects of the present disclosure is shown. Figure 5B is an inferior perspective cutaway view of the grill **500** of Figure 5A rotated approximately 60 degrees. Figure 5C is a perspective view of a charcoal pan **501** for use with the grill of Figures 5A-5B. Figure 5D is a front cutaway view of the grill **500** while Figure 5E is a side cutaway view of the grill **500**.

As with previous embodiments, the exterior of the grill **500** is substantially similar to the grill **100** discussed above. The grill **500** utilizes a charcoal pan **501** providing a substantially flat or planar supporting surface **510** capable of retaining and supporting a charcoal bed **202**. The supporting surface **510** may be bounded by a perimeter wall **512**. The illustrated embodiment of the charcoal pan **501** is rectilinear but other embodiments may be configured to fit into oval or rounded fireboxes. A plurality of diffusers **514** define air passageways or conduits **516** from below the supporting surface **510** to an area at or above a portion of the charcoal bed **202** (as best seen in Figure 5D). In the present embodiment the diffusers are conic sections terminating in an air opening **522**. The height of the air openings **522** relative to the support surface **510** may be from about .5 inches to about 1 inch to accommodate at least one layer of standard charcoal briquettes on the supporting surface **510**.

As can be seen in Figure 5C, the diffusers **514** may be lined up front to back in parallel lines. Distances between the diffusers **514** arranged in parallel lines may range from about 4 inches to about 5 inches to accommodate at least two charcoal briquettes side by side (e.g., as seen in Figure 5D). The diffusers **514** may also be arranged on parallel lines running from one side of the pan **501** to the other. In other embodiments, the diffusers **415** may be equidistantly spaced in a grid or other repeating pattern.

Figure 5D illustrates exemplary airflow within the grill **500**. The diffusers **514** operate to transport air flow from below the pan **501** to an area above at least a portion of the charcoal bed **202** in order to promote burning from the top of the bed downward and to reduce the chance of ash contacting food cooking on the food grate **190**.

5 Referring now to Figure 6A, an inferior perspective cutaway view of a cooking grill **600** according to aspects of the present disclosure is shown. Figure 3B is an inferior perspective cutaway view of the grill **500** of Figure 6A rotated approximately 60 degrees. Figure 6C is a perspective view of a charcoal pan **601** for use with the grill **600** of Figures 6A-6B. Figure 6D is a front cutaway view of the grill **600** and Figure 6E is a  
10 side cutaway view of the grill **600**.

The grill **600**, and particularly the grill pan **601**, is similar to the components described above with respect to the grill **500** of Figures 5A-5E. The grill pan **601** provides a plurality of conic diffusers **614** defining a conduit **616** from below a support surface **610** to a height above the support surface **610** equal to or greater than a standard  
15 charcoal briquette. An opening **622** in the top of the diffusers **614** may be from about .5 inches to about 1 inch above the support surface **610**. The arrangement of the diffusers **614** on the support surface **610** may be altered from that shown as discussed above with respect to the charcoal pan **501** of grill **500**. Spacing between diffusers **614** (or rows of diffusers **614**) may range from about 4 inches to about 5 inches.

20 Some or all of the diffusers **614** are provided with a cap **615** to be placed over the top of the diffuser **614** but not to plug the openings **622**. In this way, the caps **615** can serve to prevent fat, drippings, and/or other debris from the cooking grill **190** from falling past the charcoal pan **601** and down into the firebox **104**. A tab, riser, or other linkage (not shown) may locate each cap **615** with respect to its associated diffuser **614**. Figure  
25 6D illustrates possible airflow through the charcoal pan **601** and around the caps **615** to the area above the support surface **610**.

It will be appreciated that the various charcoal pans of the present disclosure (e.g., pans **200**, **301**, **401**, **501**, **601**) and their associated components may be formed from machining, casting, punching, folding, spot welding, soldering and other means. In some  
30 cases, the components may be ceramic coated, or formed from sheet metals with other heat resistant coatings. The pans **200**, **301**, **401**, **501**, **601** are also suitable for use in

grills that accommodate charcoal only (whether gas started or otherwise), or in grills that are convertible to utilize charcoal or gas. In some embodiments, the pans **200**, **301**, **401**, **501**, **601** are removable from the firebox **104** and in other embodiments they are affixed thereto.

5 As alluded to previously, one benefit of the solutions of the present disclosure is that fire burns from the top down on the charcoal bed **202**, and less of the radiant heat from the burning pieces of charcoal is radiated downwards away from the grate **190** and food being cooked. This produces more efficient burning, which can translate into lower usage of charcoal. A second benefit is that the air conduits and diffuser features can be  
10 placed so as to produce the most even possible generation of heat across the bed of burning charcoal **202**. A third benefit is that the placement of the ducts and diffusers can provide a short path from the air outlet at the top of the diffuser to any part of the charcoal bed **202** allowing for prompt development of the fire across the entire bed **202** following ignition.

15 Unexpectedly, it has also been found that there is much less tendency for grease drippings from food to ignite in the bed of burning charcoal **202** with the various embodiments of the present disclosure. Air supply to the charcoal **202** and the amount of charcoal on the bed **202** may be controlled to reduce the thermal draft. This during the operation the charcoal **202** will burn fewer open flames reducing the possibility of flare-  
20 ups. With reduced possibility of flare-ups, food can be cooked with close proximity to charcoal bed **202** which makes the grill more efficient. Cooking can be done with defined sear marks similar a gas grill with little to no ash deposit of ash on the food.

Although various embodiments of the present disclosure are described and shown as being loaded with charcoal briquettes, it is understood that the embodiments of the  
25 present disclosure may also be utilized with lump or natural charcoal with similar or identical satisfactory results and improvements.

\* \* \* \* \*

Thus, the present invention is well adapted to carry out the objectives and attain the ends and advantages mentioned above as well as those inherent therein. While  
30 presently preferred embodiments have been described for purposes of this disclosure, numerous changes and modifications will be apparent to those of ordinary skill in the art.

It is to be understood that the terms "including", "comprising", "consisting" and grammatical variants thereof do not preclude the addition of one or more components, features, steps, or integers or groups thereof and that the terms are to be construed as specifying components, features, steps or integers.

5 If the specification or claims refer to "an additional" element, that does not preclude there being more than one of the additional element.

It is to be understood that where the claims or specification refer to "a" or "an" element, such reference is not be construed that there is only one of that element.

10 It is to be understood that where the specification states that a component, feature, structure, or characteristic "may", "might", "can" or "could" be included, that particular component, feature, structure, or characteristic is not required to be included.

15 Where applicable, although state diagrams, flow diagrams or both may be used to describe embodiments, the invention is not limited to those diagrams or to the corresponding descriptions. For example, flow need not move through each illustrated box or state, or in exactly the same order as illustrated and described.

Methods of the present invention may be implemented by performing or completing manually, automatically, or a combination thereof, selected steps or tasks.

20 The term "method" may refer to manners, means, techniques and procedures for accomplishing a given task including, but not limited to, those manners, means, techniques and procedures either known to, or readily developed from known manners, means, techniques and procedures by practitioners of the art to which the invention belongs.

25 The term "at least" followed by a number is used herein to denote the start of a range beginning with that number (which may be a range having an upper limit or no upper limit, depending on the variable being defined). For example, "at least 1" means 1 or more than 1. The term "at most" followed by a number is used herein to denote the end of a range ending with that number (which may be a range having 1 or 0 as its lower limit, or a range having no lower limit, depending upon the variable being defined). For example, "at most 4" means 4 or less than 4, and "at most 40%" means 40% or less than  
30 40%. Terms of approximation (e.g., "about", "substantially", "approximately", etc.) should be interpreted according to their ordinary and customary meanings as used in the

associated art unless indicated otherwise. Absent a specific definition and absent ordinary and customary usage in the associated art, such terms should be interpreted to be  $\pm 10\%$  of the base value.

When, in this document, a range is given as “(a first number) to (a second  
5 number)” or “(a first number) – (a second number)”, this means a range whose lower limit is the first number and whose upper limit is the second number. For example, 25 to 100 should be interpreted to mean a range whose lower limit is 25 and whose upper limit is 100. Additionally, it should be noted that where a range is given, every possible subrange or interval within that range is also specifically intended unless the context  
10 indicates to the contrary. For example, if the specification indicates a range of 25 to 100 such range is also intended to include subranges such as 26 -100, 27-100, etc., 25-99, 25-98, etc., as well as any other possible combination of lower and upper values within the stated range, e.g., 33-47, 60-97, 41-45, 28-96, etc. Note that integer range values have been used in this paragraph for purposes of illustration only and decimal and fractional  
15 values (e.g., 46.7 – 91.3) should also be understood to be intended as possible subrange endpoints unless specifically excluded.

It should be noted that where reference is made herein to a method comprising two or more defined steps, the defined steps can be carried out in any order or simultaneously (except where context excludes that possibility), and the method can also  
20 include one or more other steps which are carried out before any of the defined steps, between two of the defined steps, or after all of the defined steps (except where context excludes that possibility).

## CLAIMS

What is claimed is:

1. A charcoal pan for use within a grill comprising:  
  
a supporting surface for supporting a quantity of charcoal beneath a cooking  
5 grate; and  
  
a plurality of diffusers that transport air from underneath the supporting surface to  
an area above at least a portion of the quantity of charcoal.
2. The charcoal pan of claim 1, wherein the plurality of air diffusers comprise a  
10 plurality of parallel peaked structures rising from the supporting surface and having at  
least one air gap facing upward from the peaks thereof.
3. The charcoal pan of claim 1, wherein the air gaps are at least .5 inches above the  
supporting surface.  
15
4. The charcoal pan of claim 3, wherein the plurality of parallel peaked structures  
are spaced apart from 4 inches to 5 inches.
5. The charcoal pan of claim 1, wherein the plurality of air diffusers comprise a  
20 plurality of parallel peaked structures rising from the supporting surface, each peaked  
structure having at least one air opening defined in a sidewall below the peak.
6. The charcoal pan of claim 5, wherein the supporting surface is bounded by a  
boundary wall defining at least one air opening therein, the at least one air opening being  
25 situated above the supporting surface.
7. The charcoal pan of claim 5, further comprising a slidable closure on each of the  
plurality of air diffusers, each slidable closure defining an opening corresponding with  
the at least one air opening of the respective air diffuser and being selectively slidable to

alter a degree of overlap between the respective adjacent openings to alter airflow volume of the diffuser.

8. The charcoal pan of claim 1, wherein the plurality of air diffusers comprise a plurality of open-topped cones rising from the supporting surface.

9. The charcoal pan of claim 8, wherein the open-topped cones each have a cover that is spaced apart from the top of the cone to define an air gap between the cover and the cone.

10

10. A charcoal pan comprising:  
a flat support surface bounded by an outer wall; and  
a plurality of air conduits defining air passageways from below the flat support surface and terminating a predetermined distance above the flat support surface.

15

11. The charcoal pan of claim 10, wherein the outer wall defines a plurality of air openings around a periphery of the flat support surface.

12. The charcoal pan of claim 10, wherein the plurality of air conduits comprises a plurality of parallel spaced apart peaked structures rising from the flat support surface and having an air opening on the peaks thereof.

13. The charcoal pan of claim 10, wherein the plurality of air conduits comprises a plurality of double walled structures rising from the flat support surface and joining at a peak, the double walled structures defining air openings in the walls.

14. The charcoal pan of claim 13, further comprising a slidable closure that selectively partially or completely covers the air openings in the walls.

15. The charcoal pan of claim 10, wherein the plurality of air conduits comprises a plurality of hollow and opened-topped conic structures rising from the flat support surface.

5 16. The charcoal pan of claim 15, further comprising a covering spaced apart from the top of each of the open-topped conic structures.

17. A method comprising:

10 providing a flat support surface bounded around the outside to contain a quantity of charcoal briquettes below a cooking grate; and

forming a plurality of air passageways allowing air flow from below the flat support surface to a predetermined level above the flat support surface.

15 18. The method of claim 17, further comprising forming the plurality of air passageways in a repeating equidistantly spaced pattern on the flat support surface.

19. The method of claim 17, further comprising providing an adjustable closure on the plurality of air passageways, the adjustable closure having at least selectable positions for complete opening of the air passageways and partial closure of the air passageways.

20

20. The method of claim 17, further comprising providing a spaced apart cover for each of the plurality of air passageways.

25

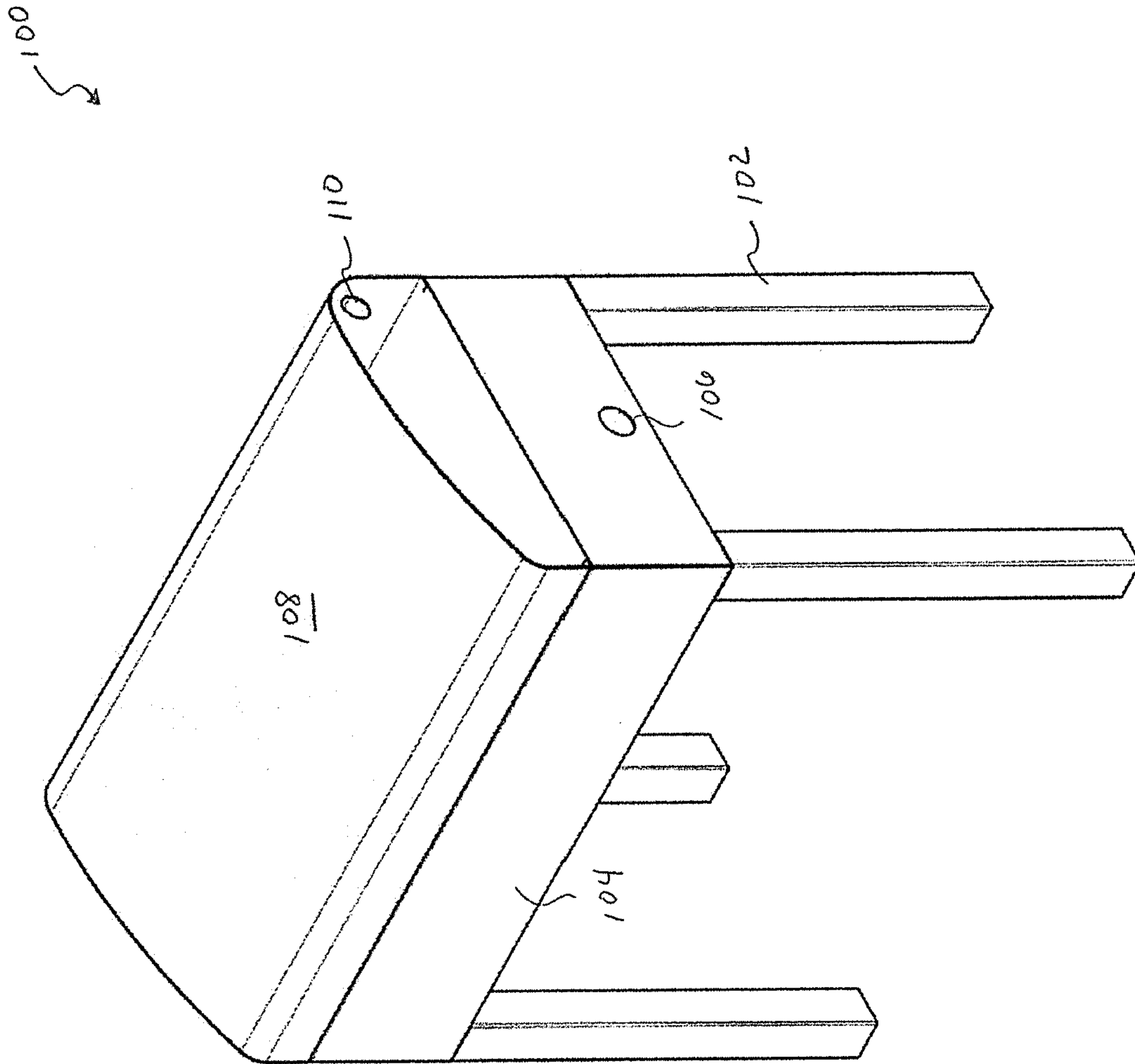

Fig. 1

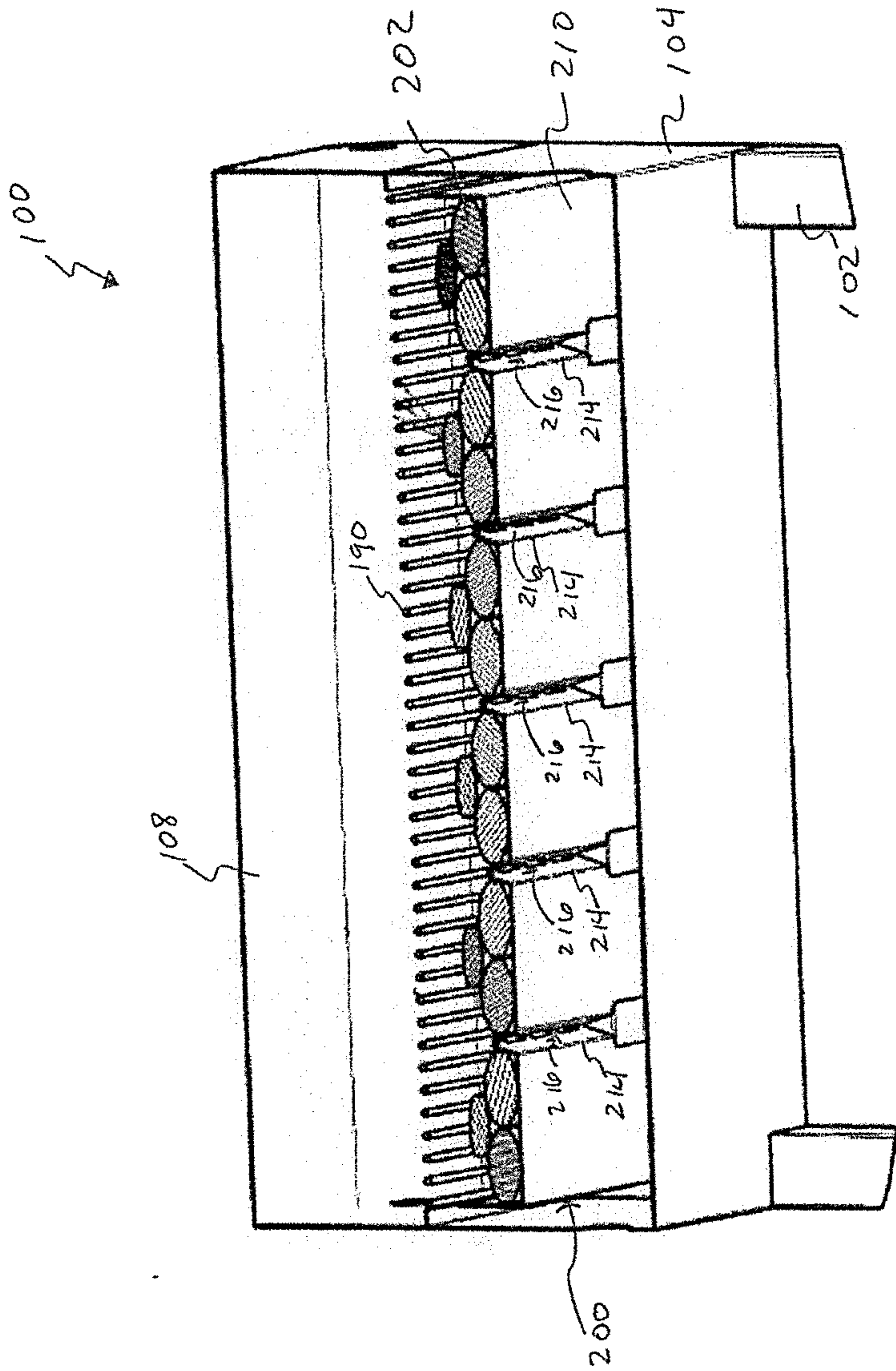

Fig. 2A

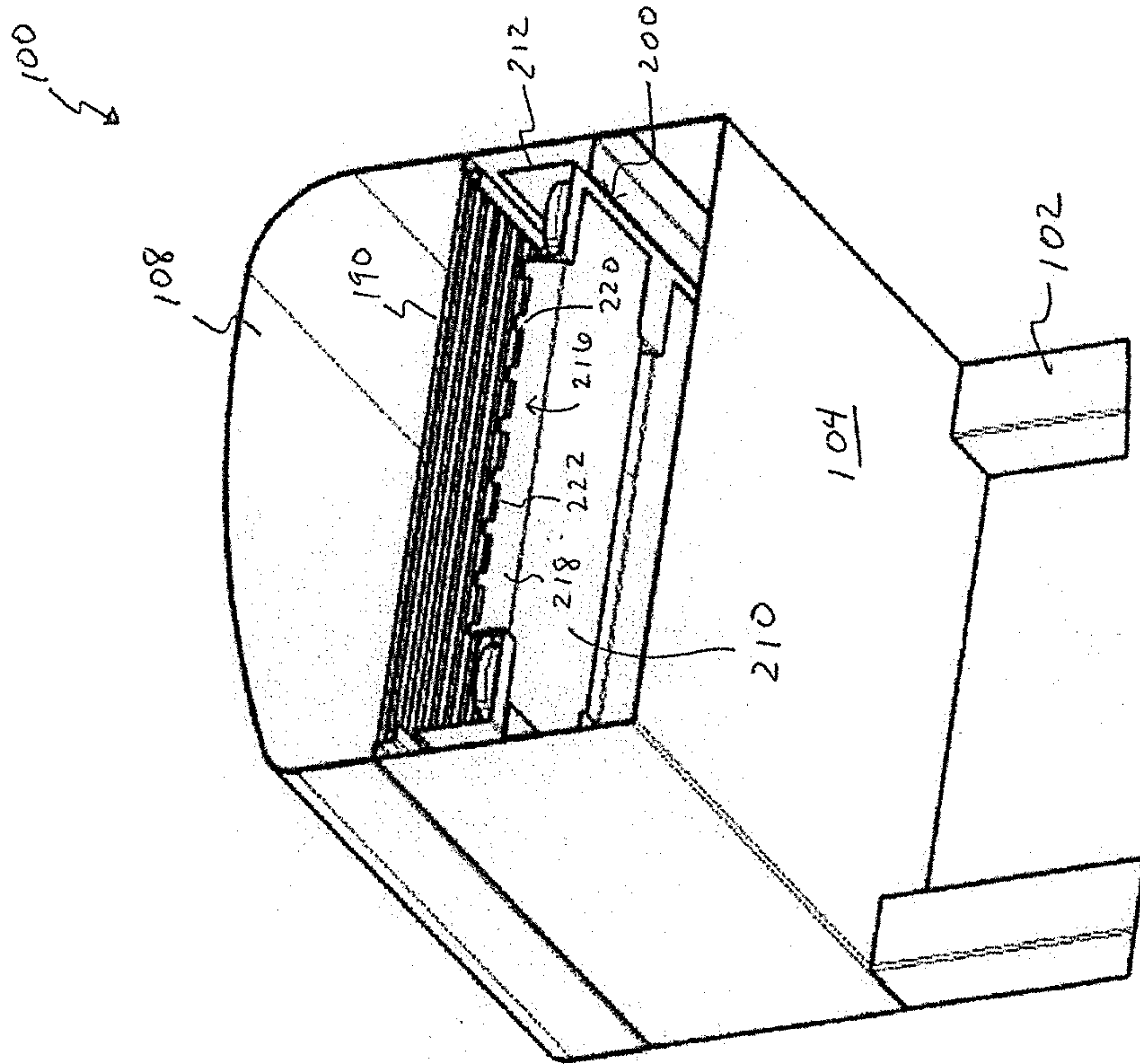

Fig. 2B

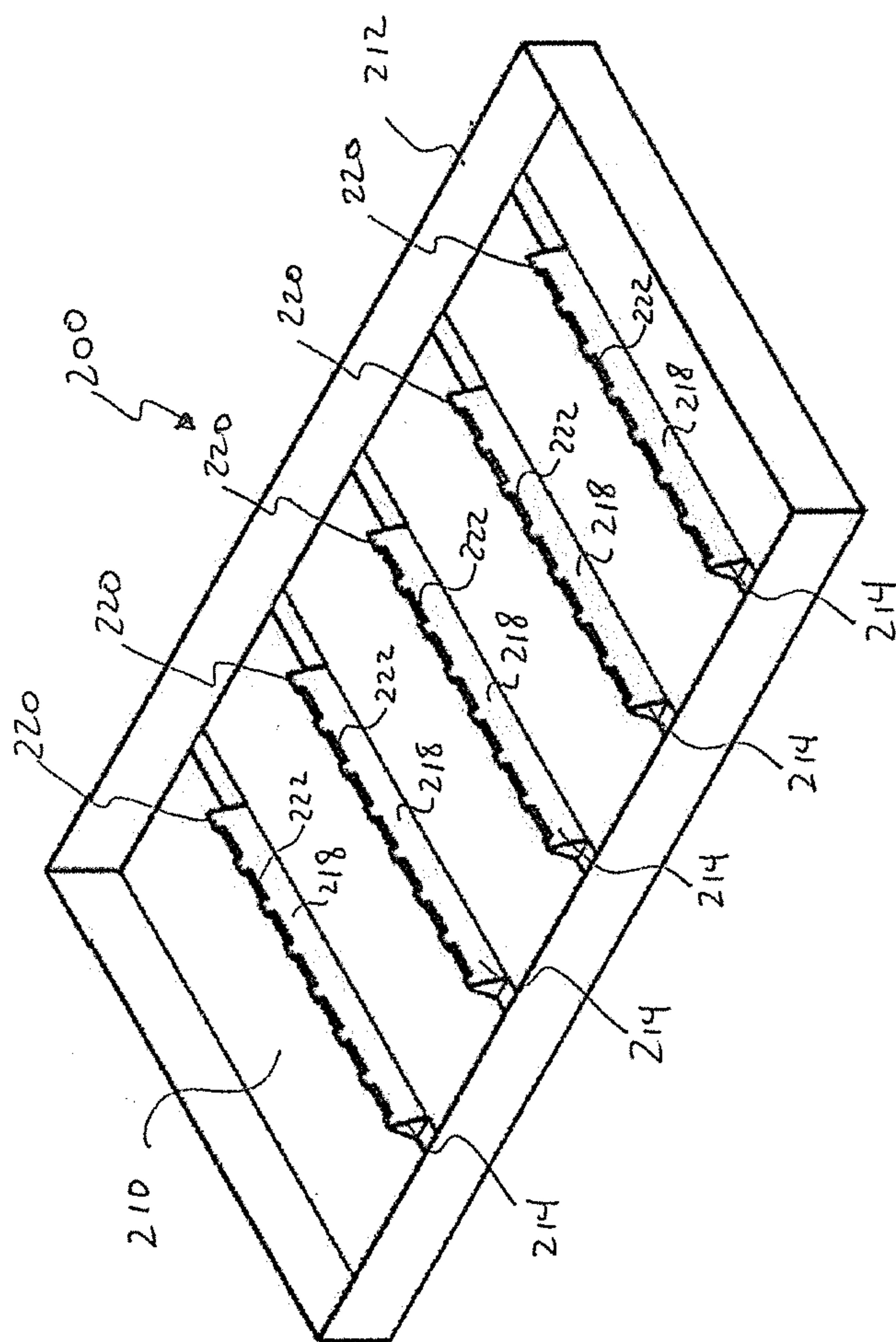

Fig. 2C

5/27

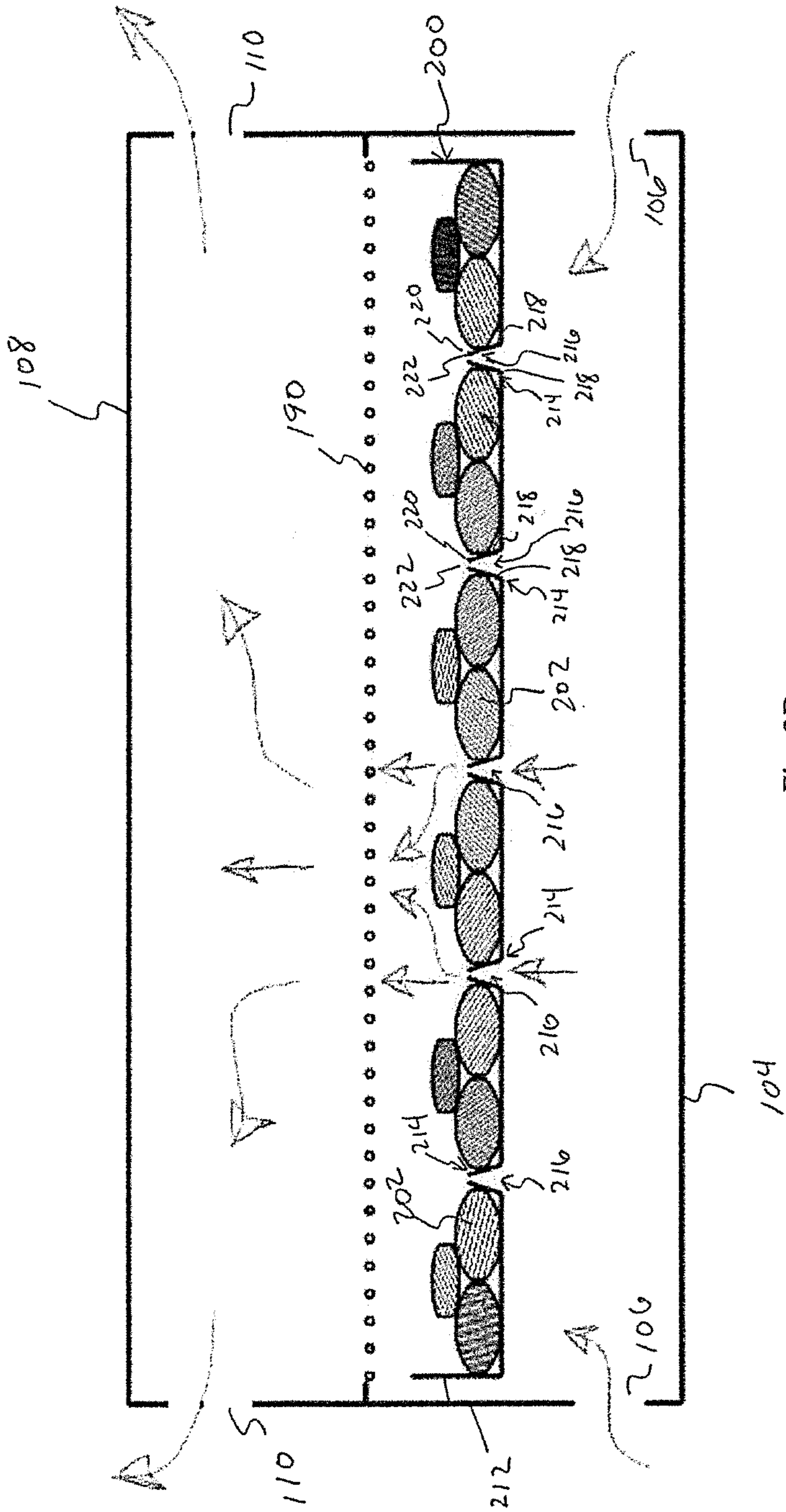

Fig. 2D

6/27

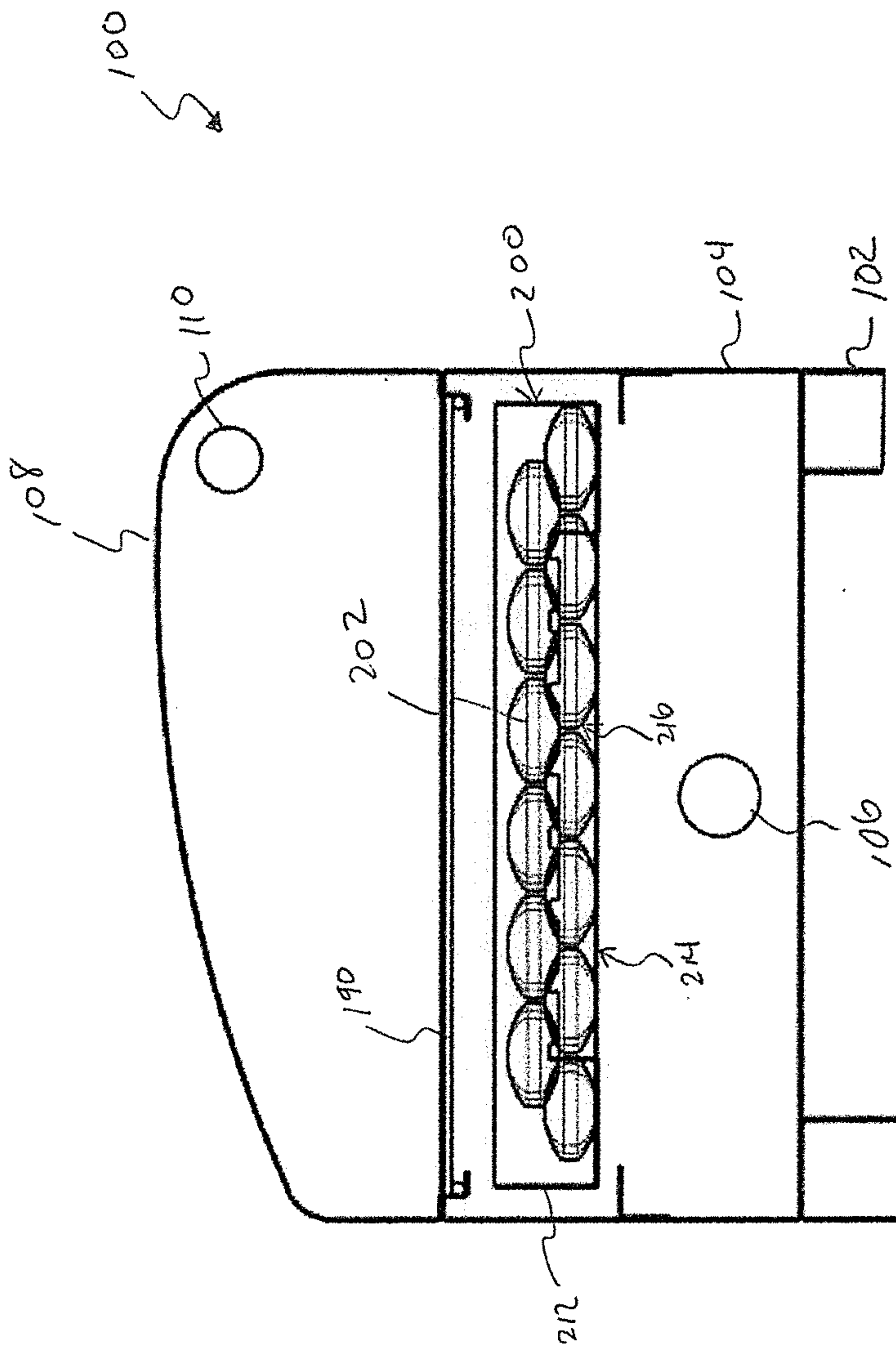

Fig. 2E

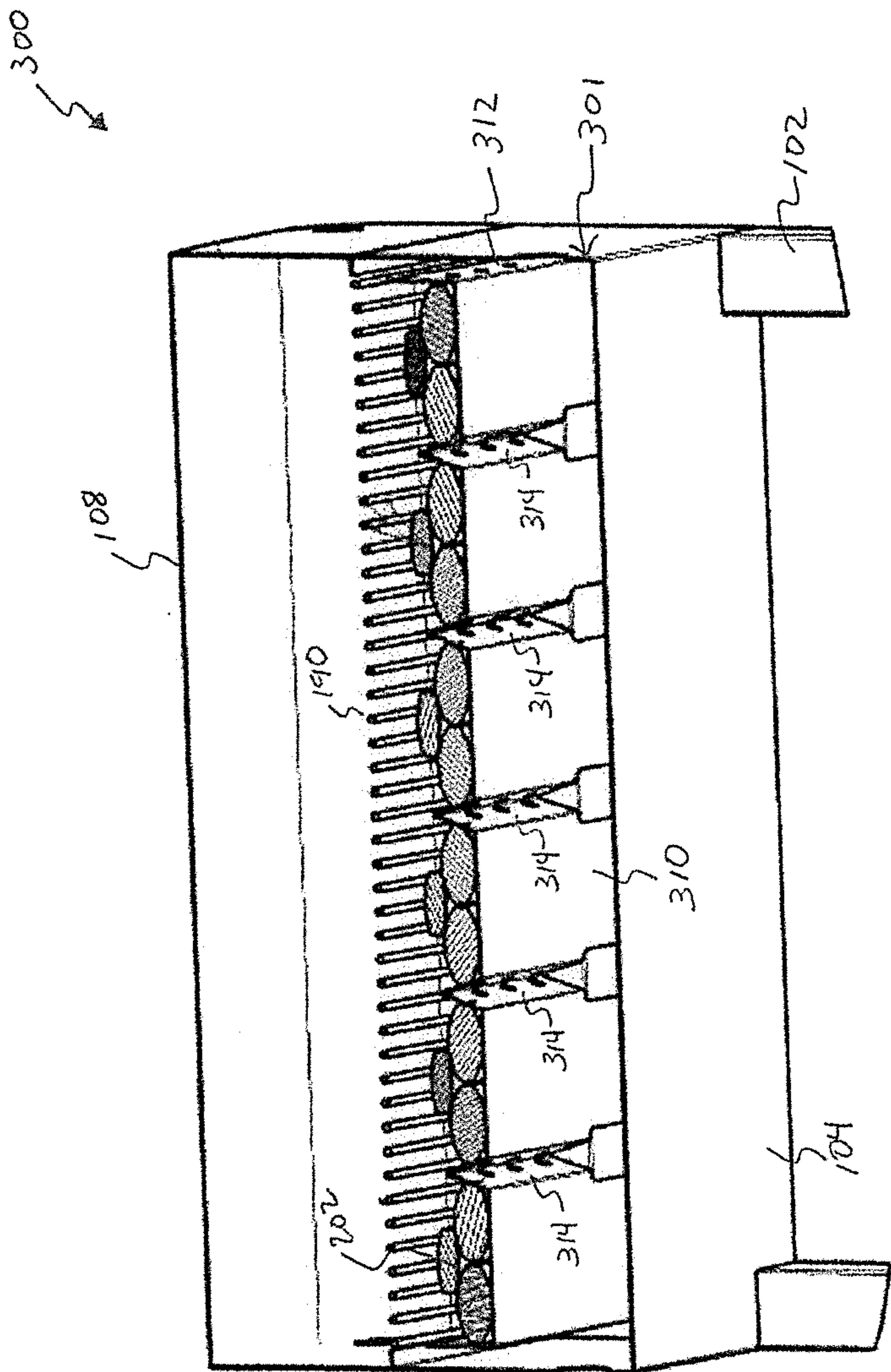

Fig. 3A

8/27

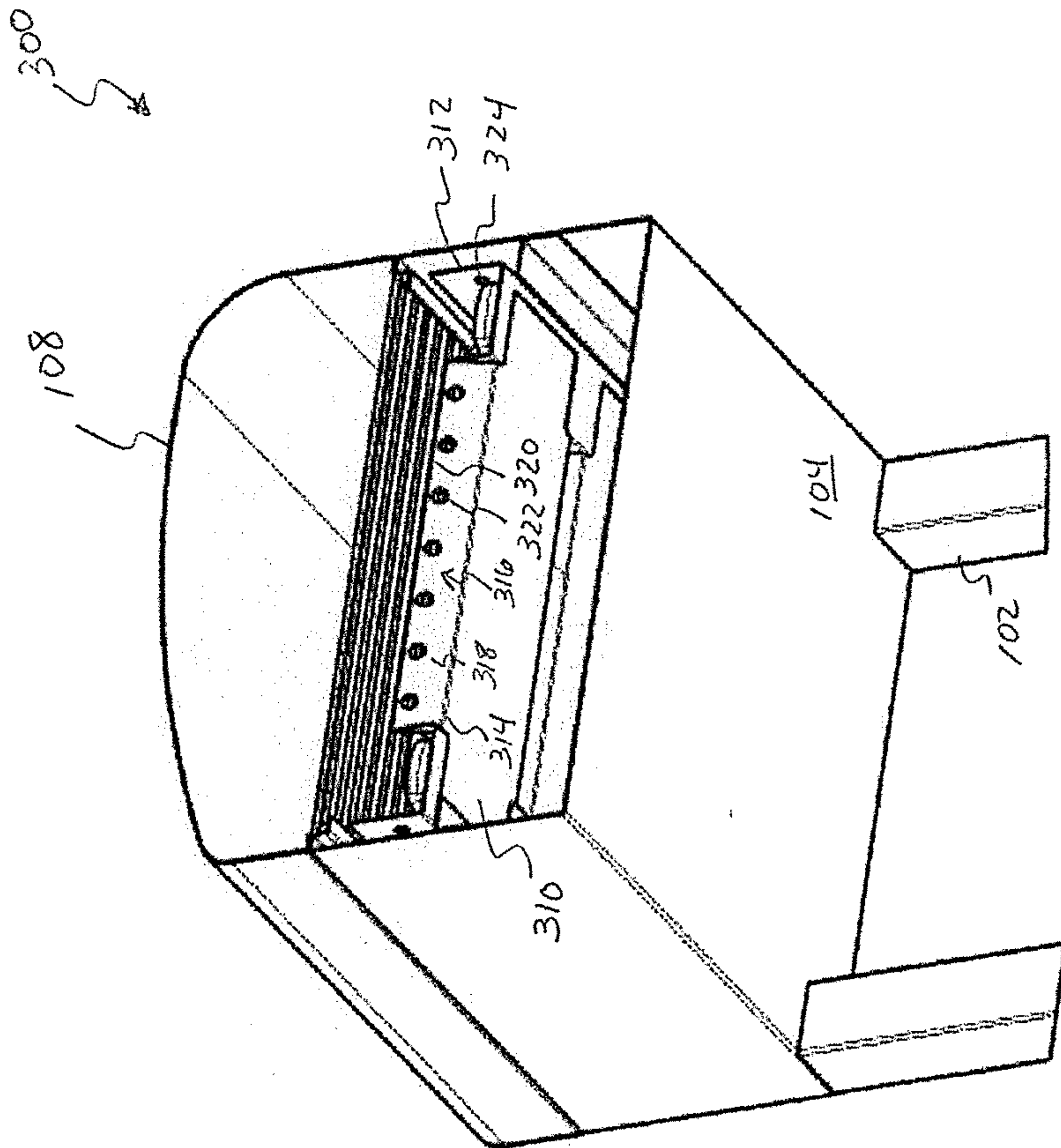

Fig. 3B

9/27

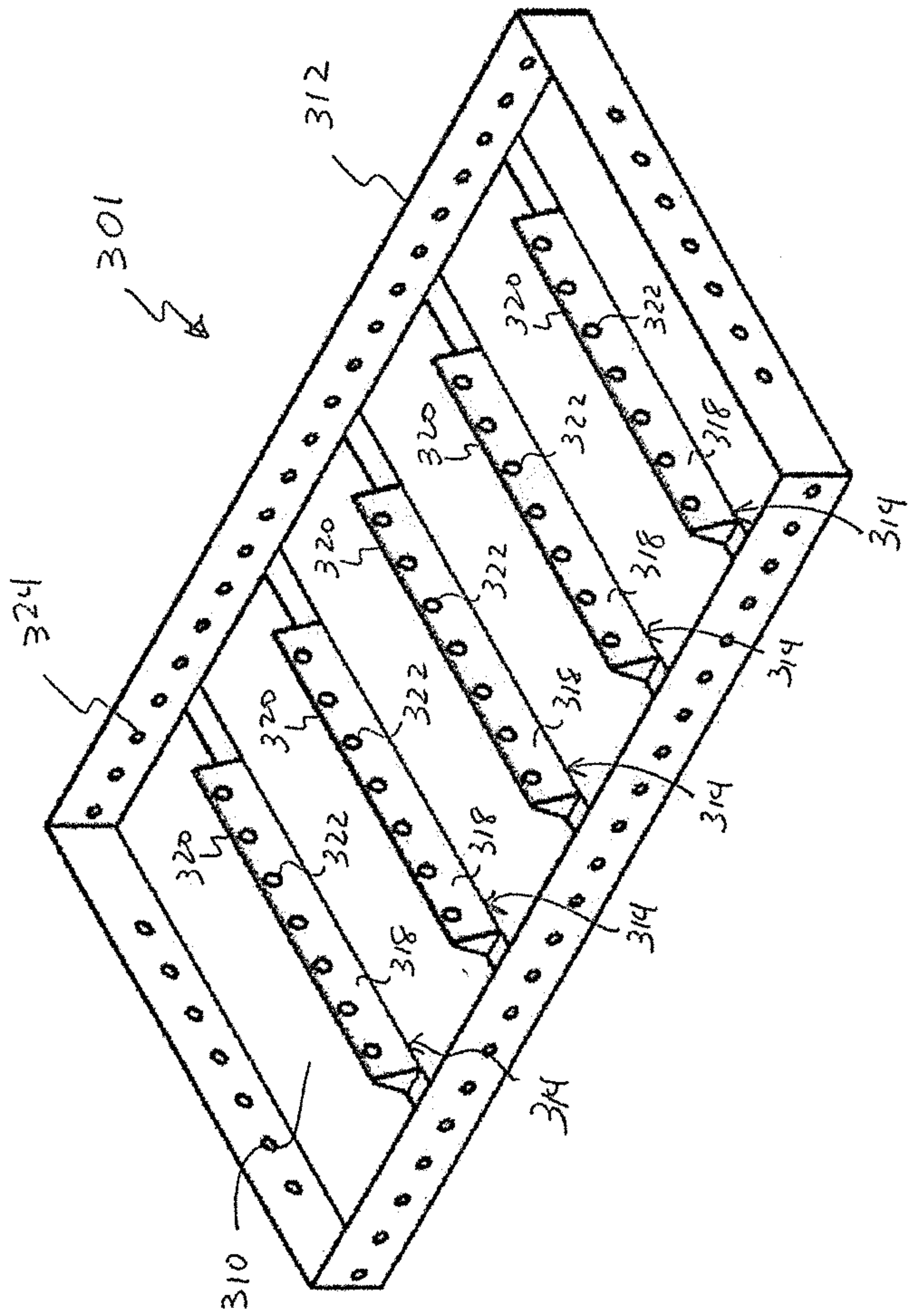

Fig. 3C

10/27

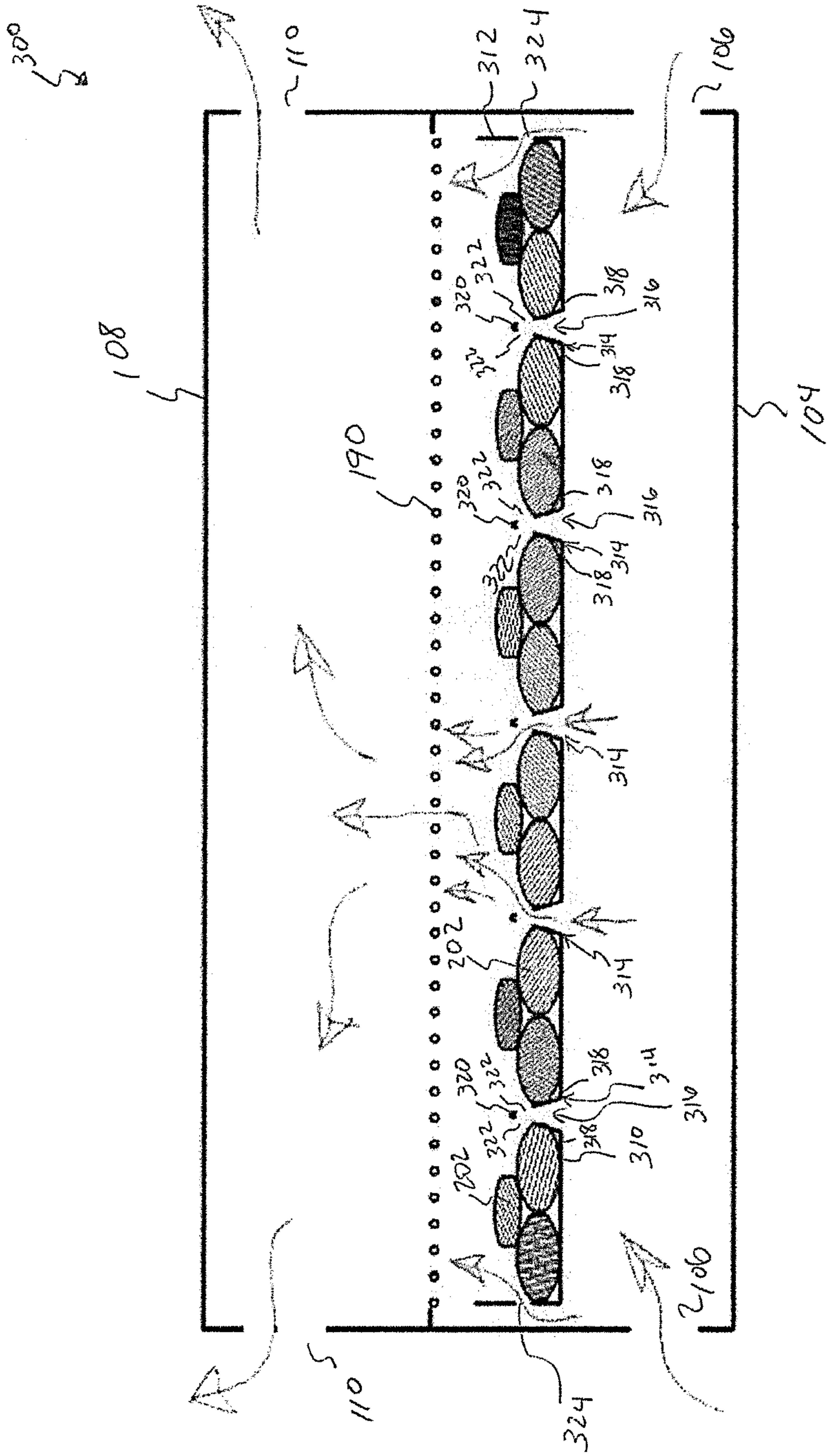

Fig. 3D

11/27

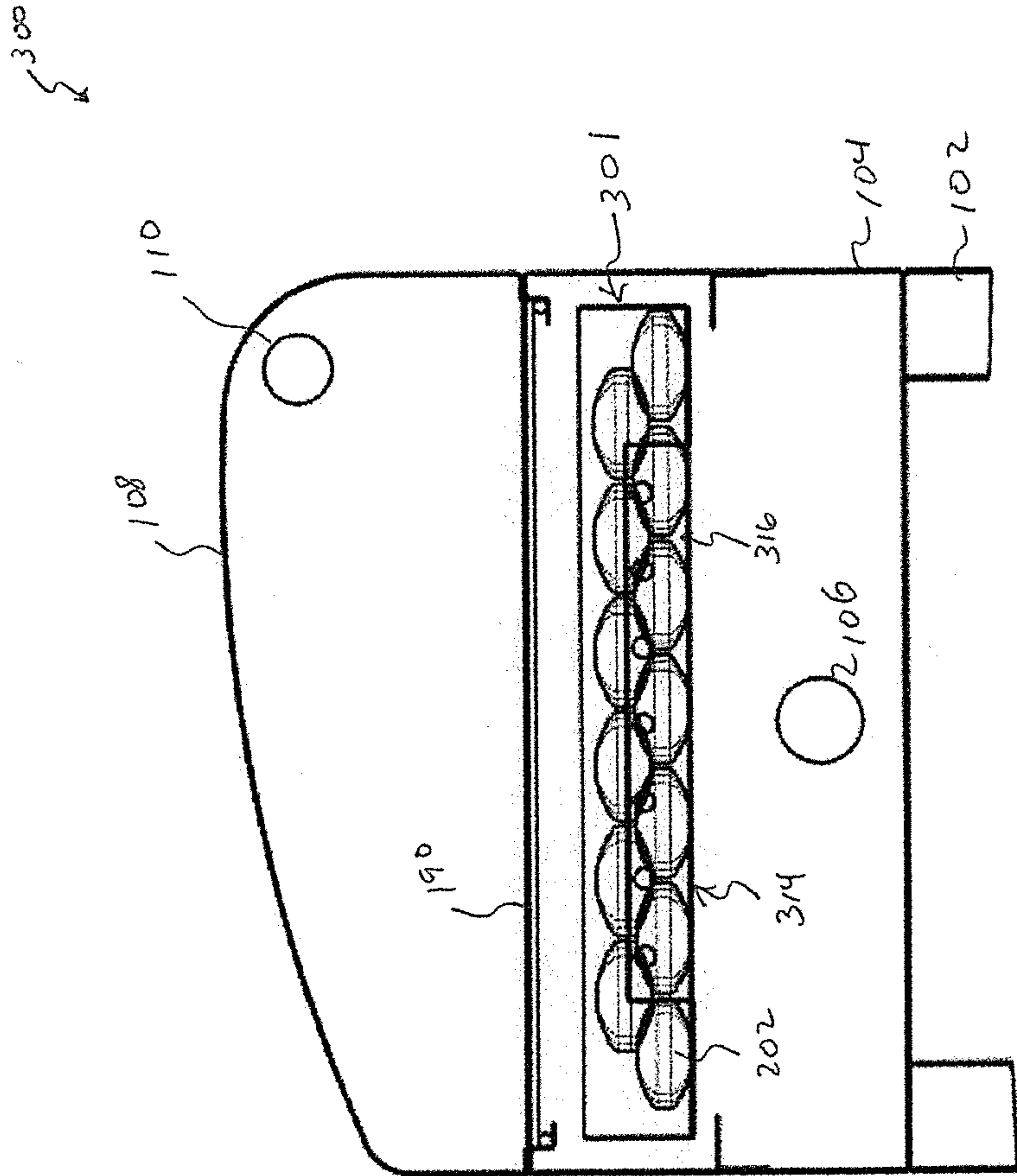

Fig. 3E

12/27

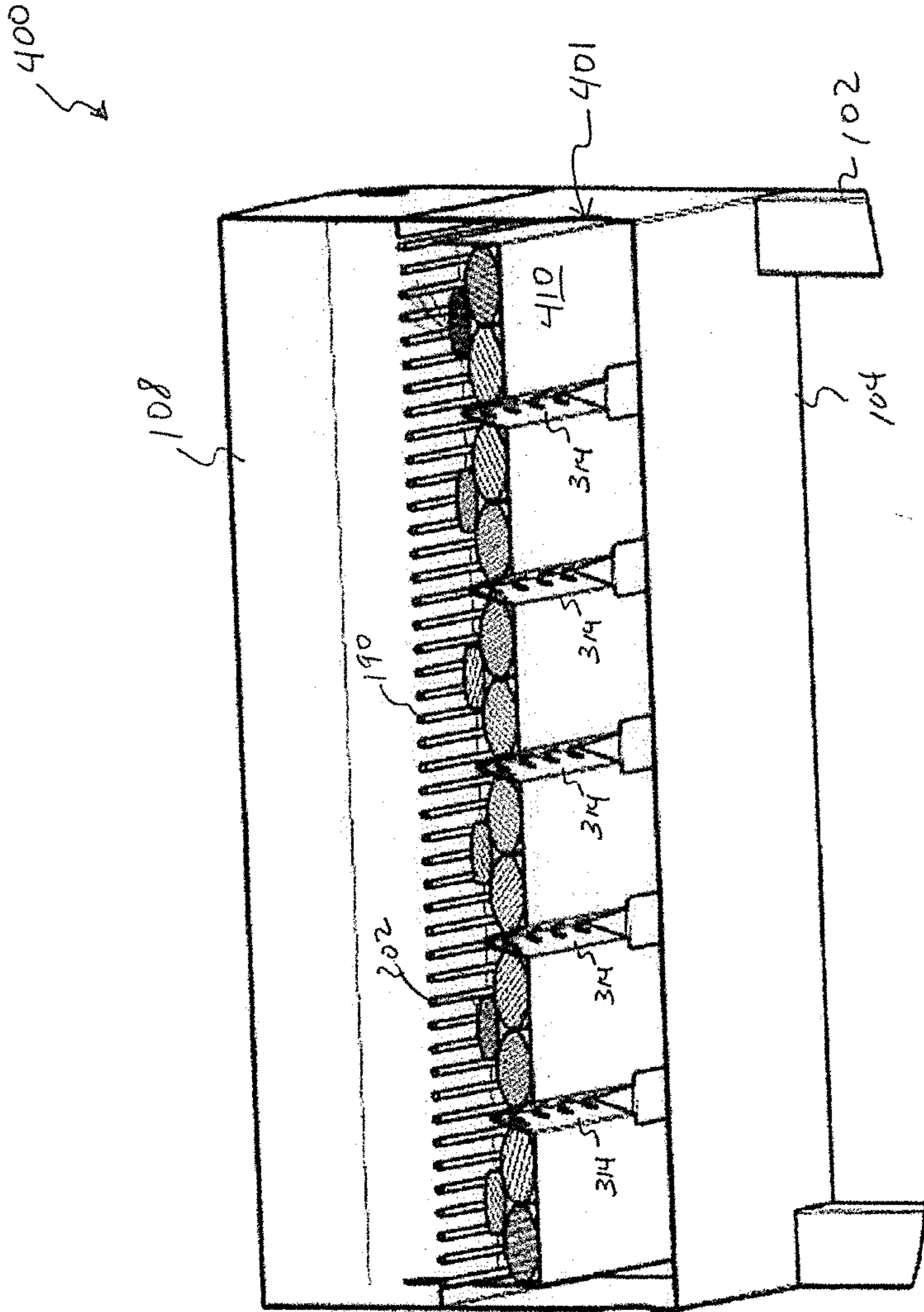

Fig. 4A

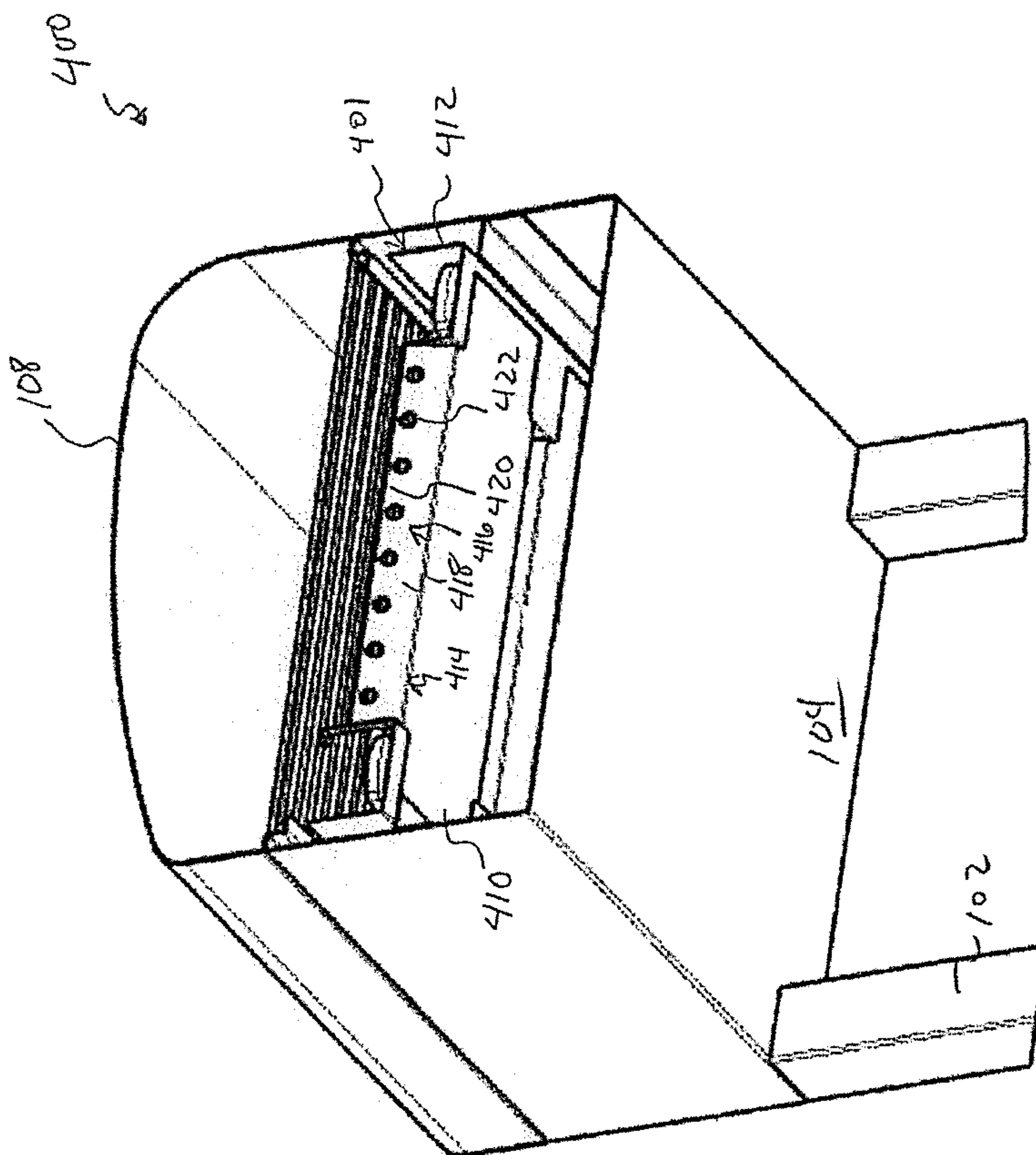

Fig. 4B

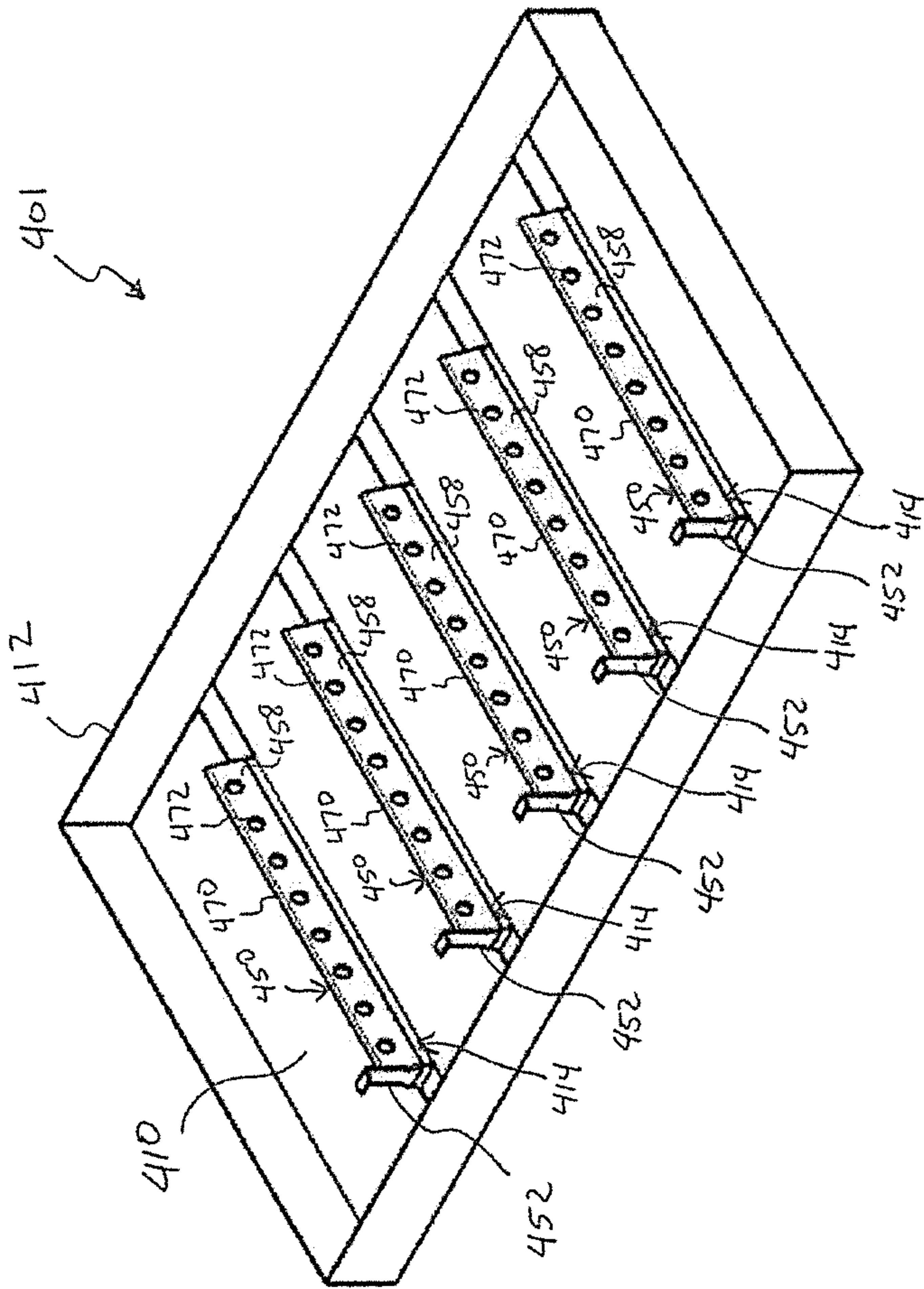

Fig. 4C

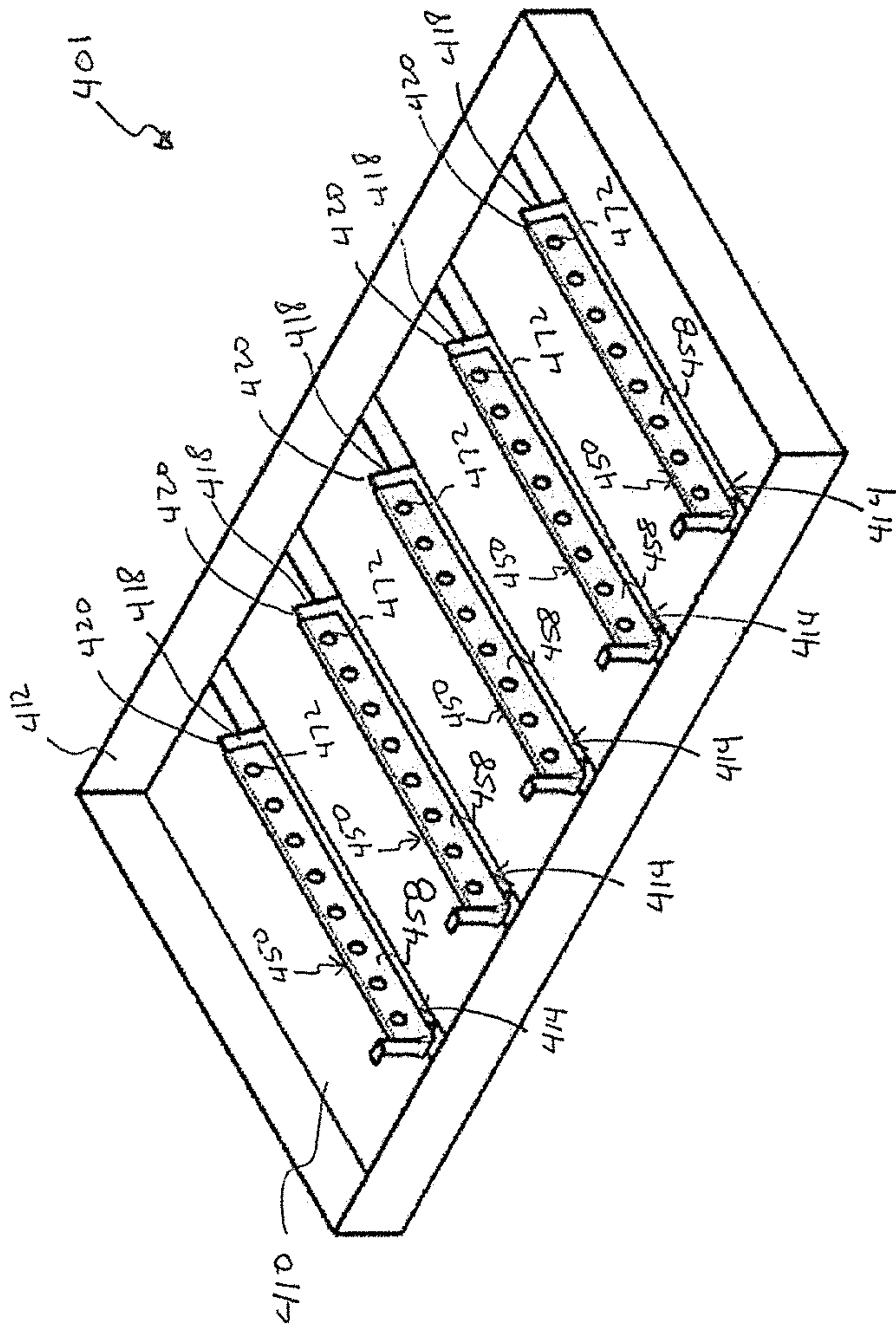

Fig. 4D



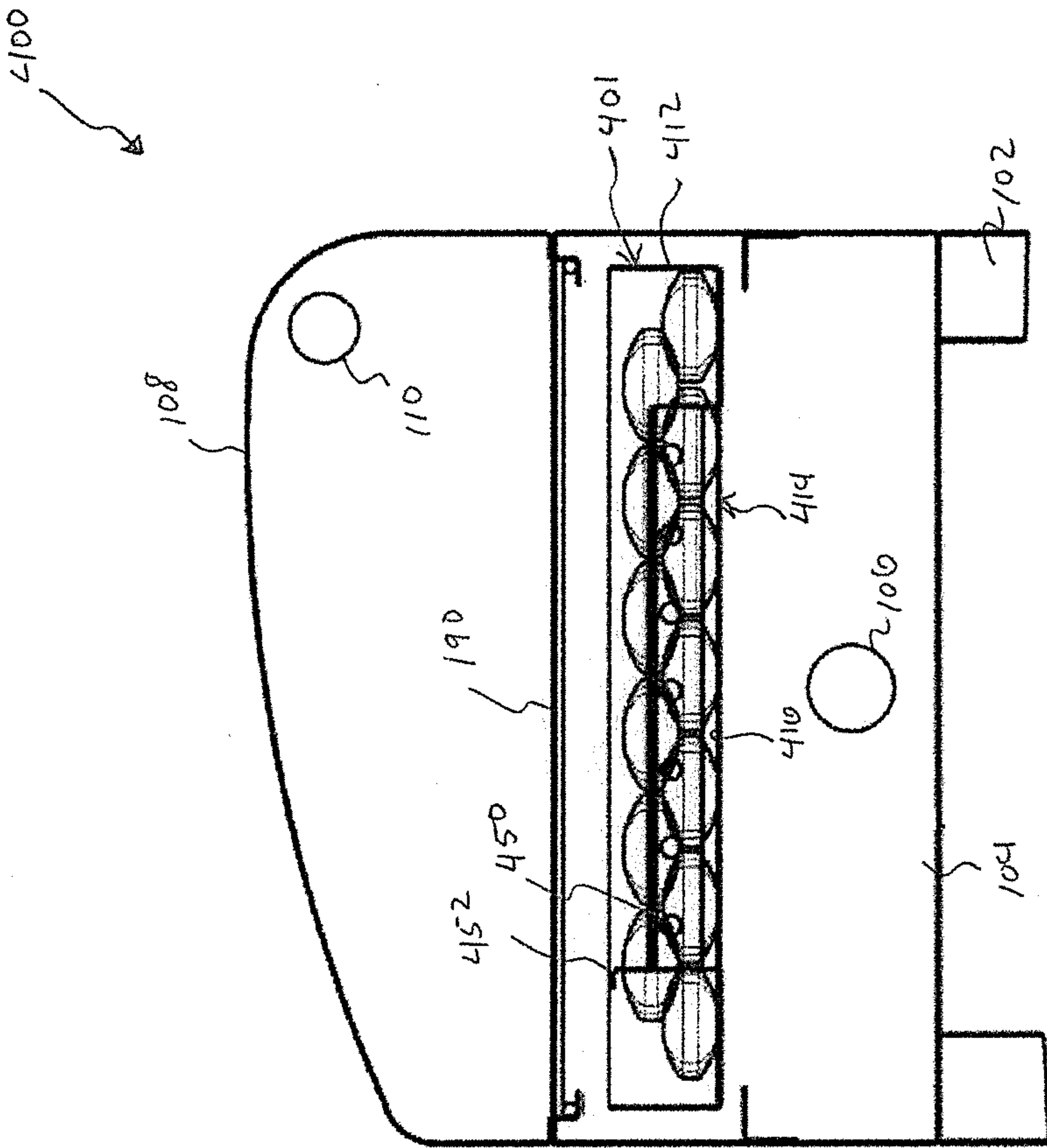

Fig. 4F

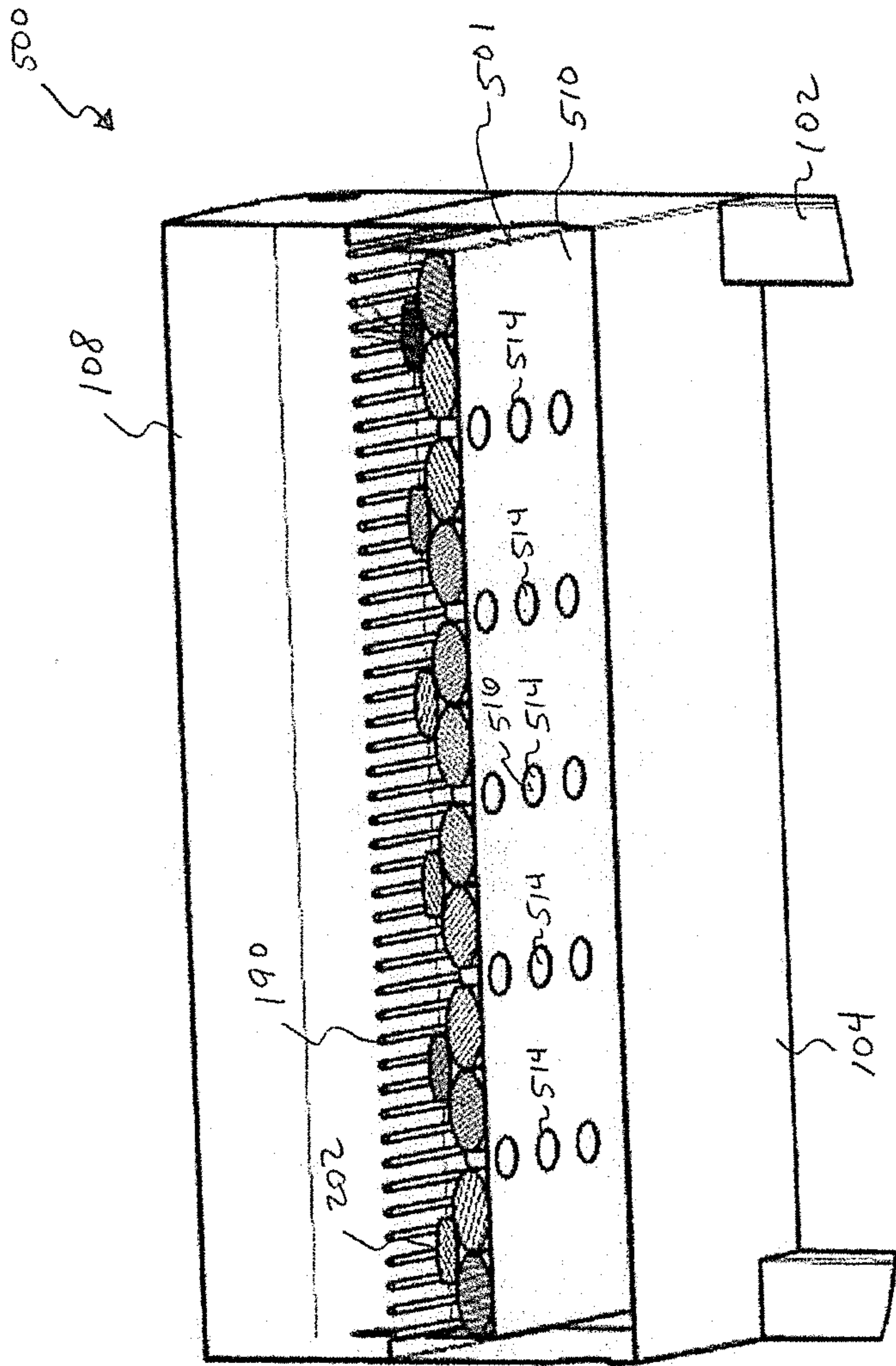

Fig. 5A

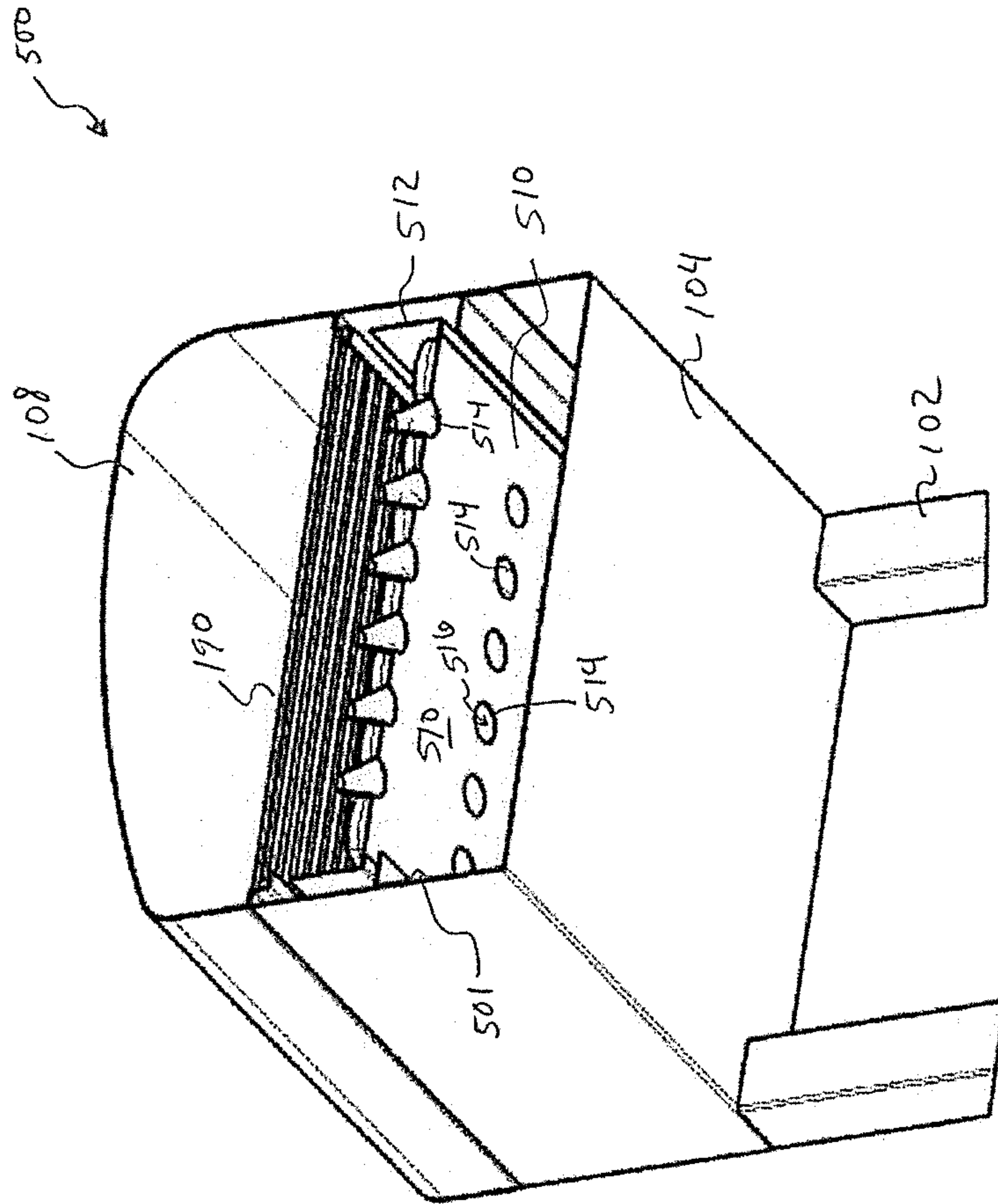

Fig. 5B

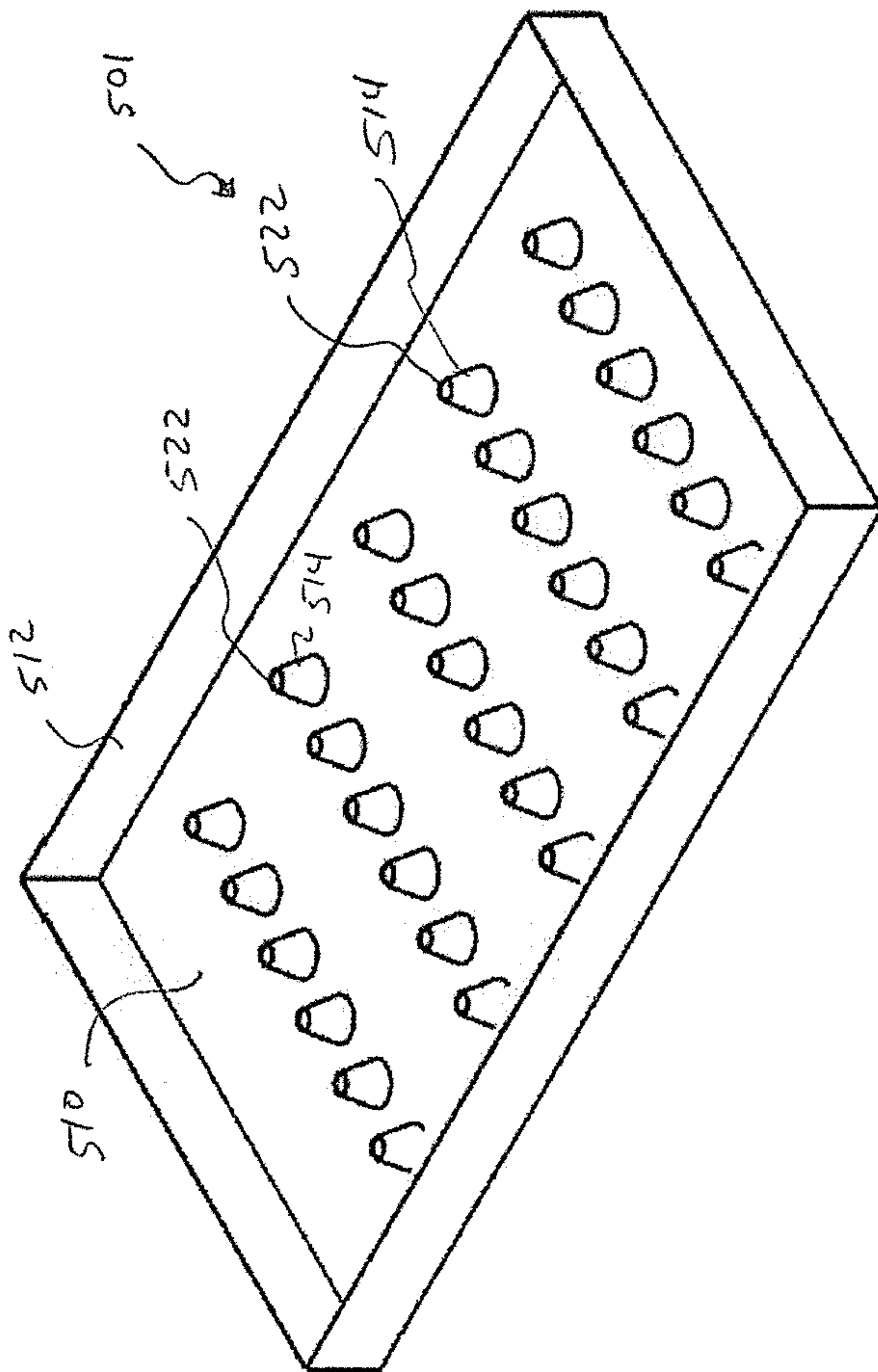

Fig. 5C

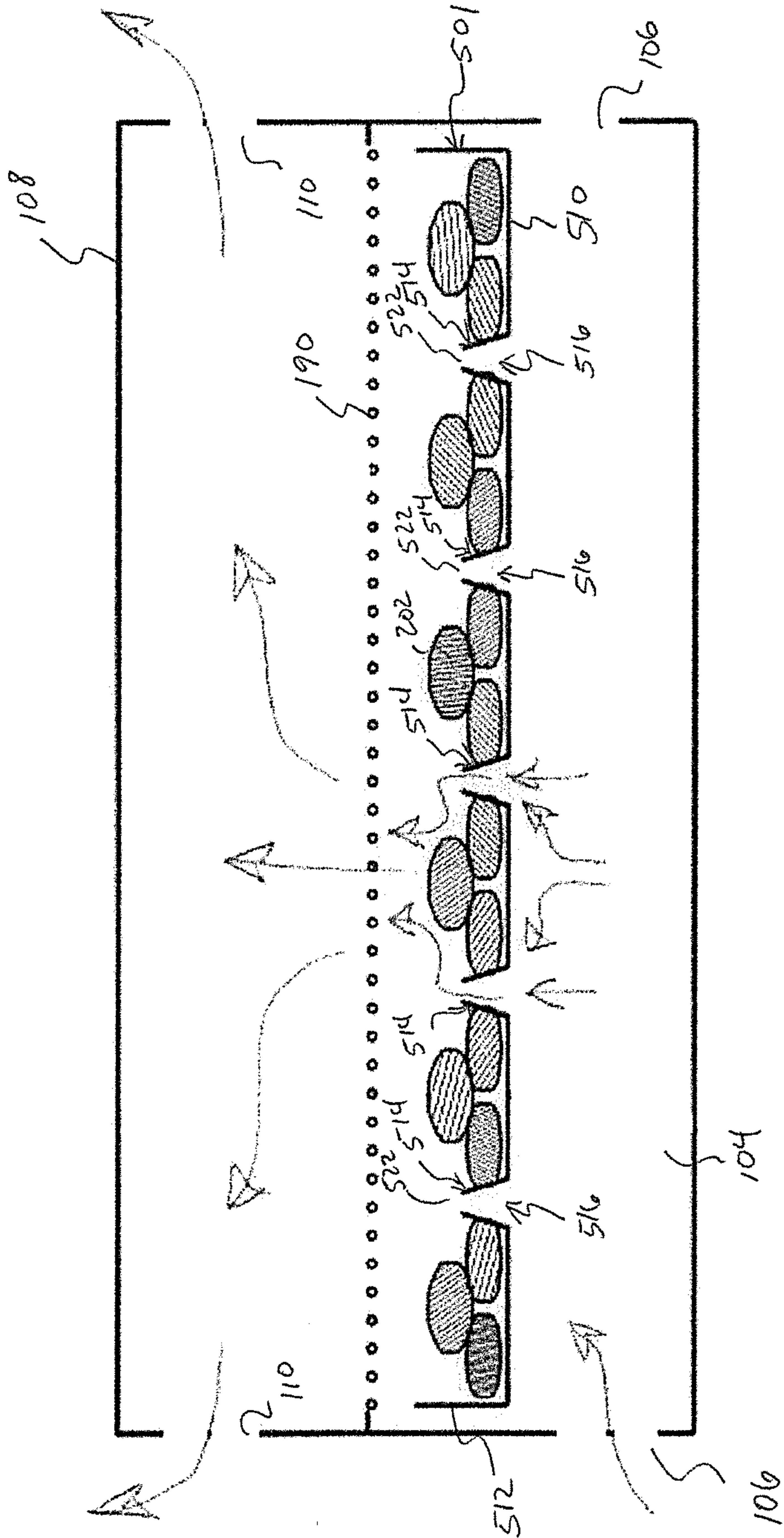

Fig. 5D

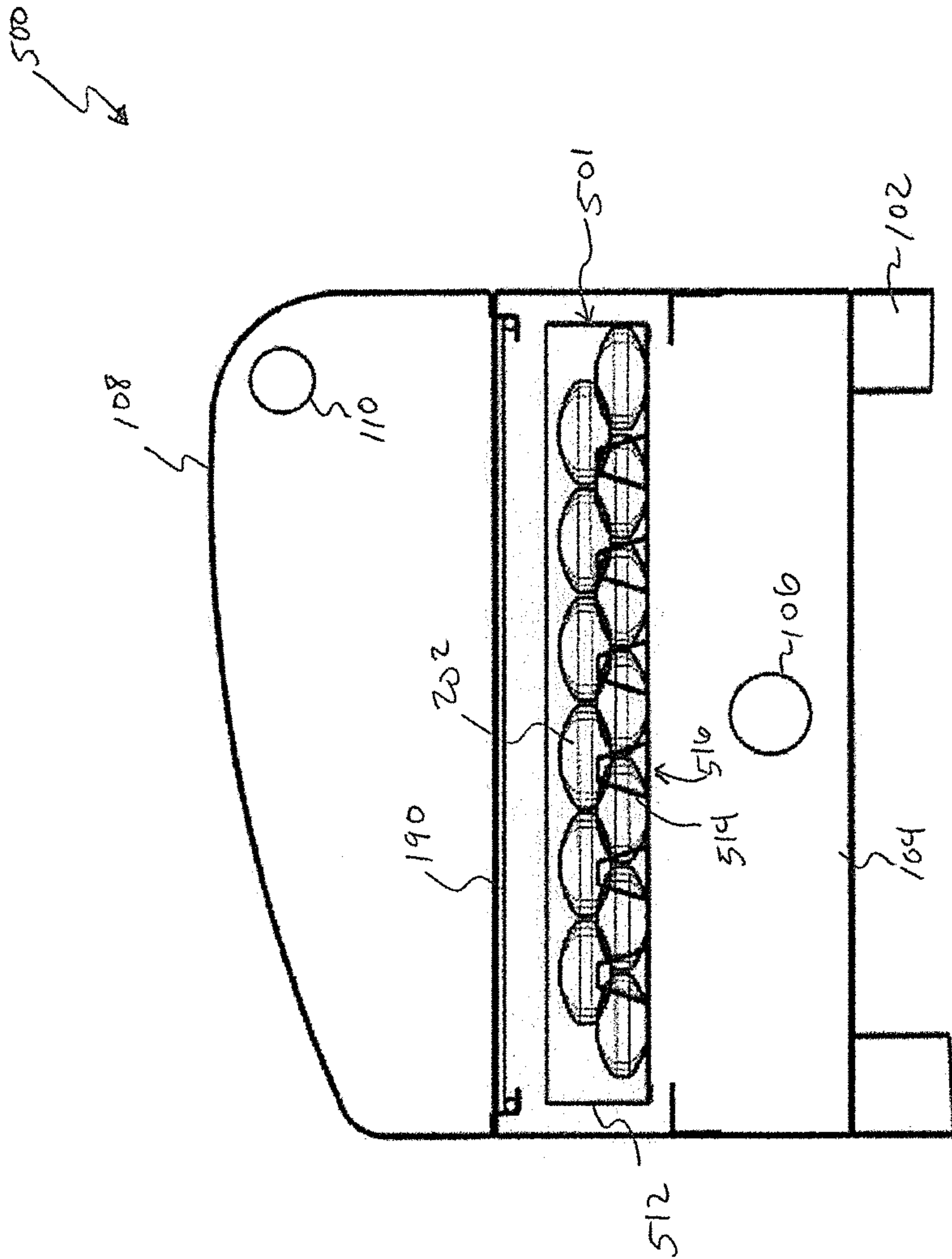

Fig. 5E

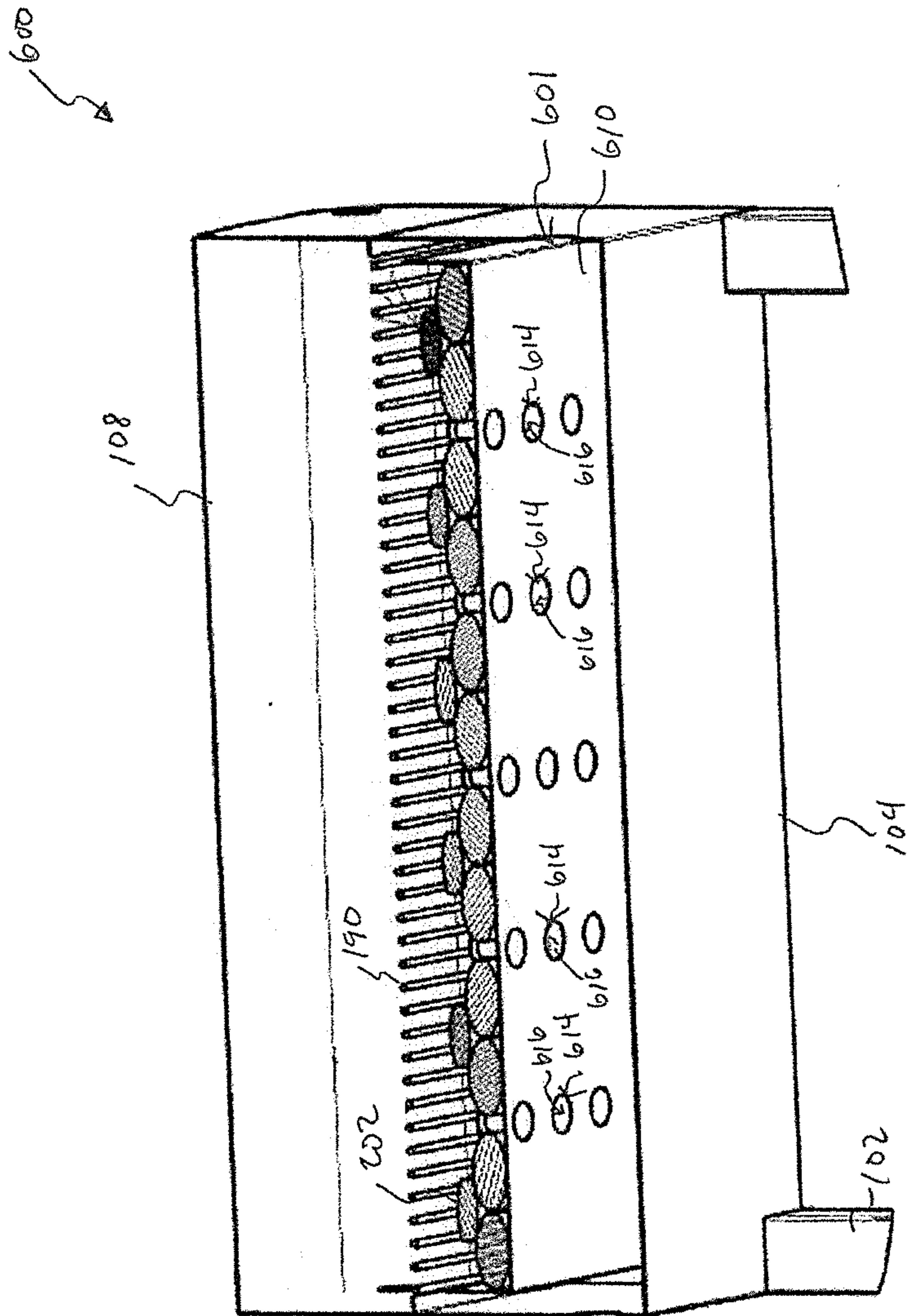

Fig. 6A

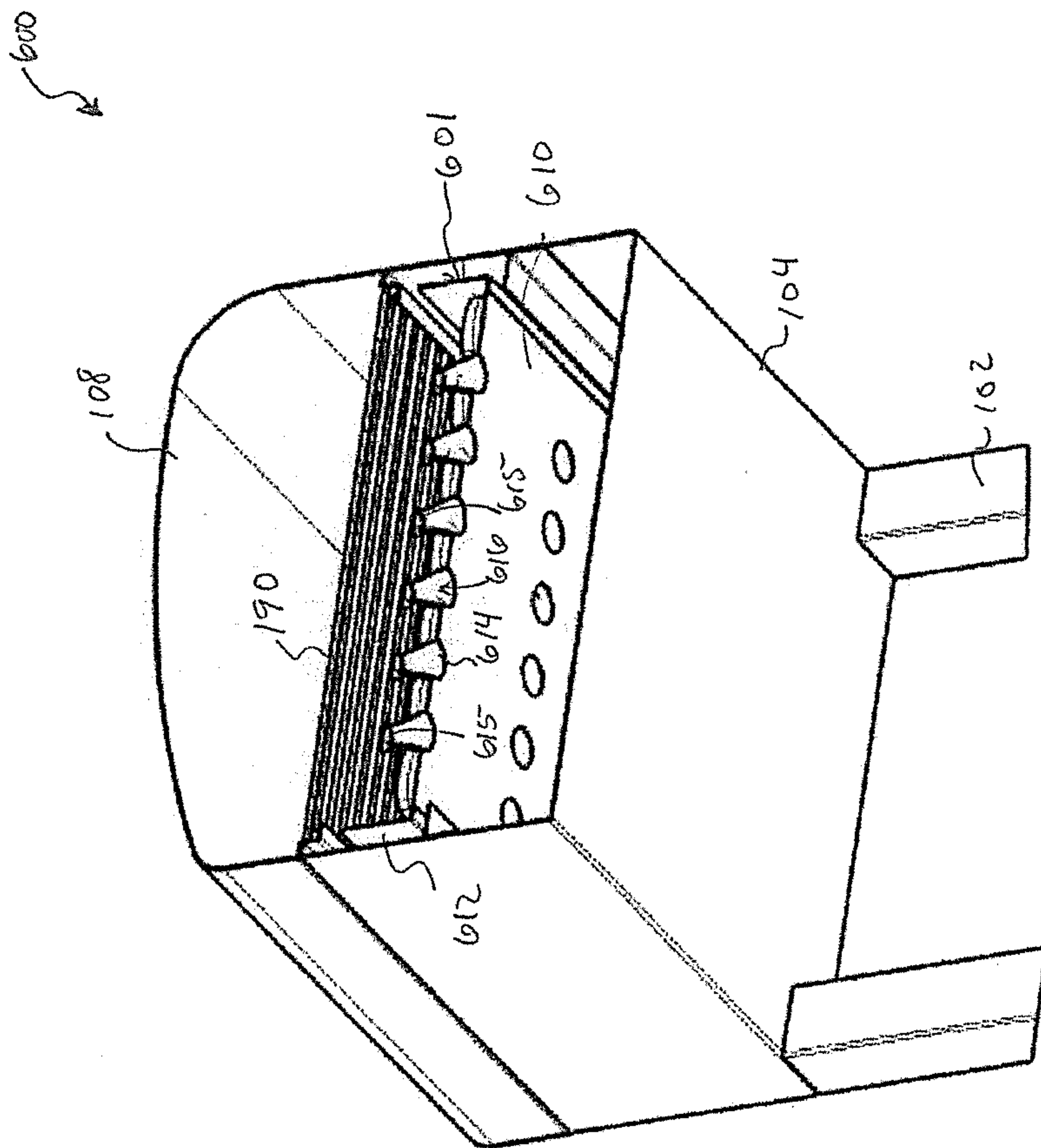

Fig. 6B

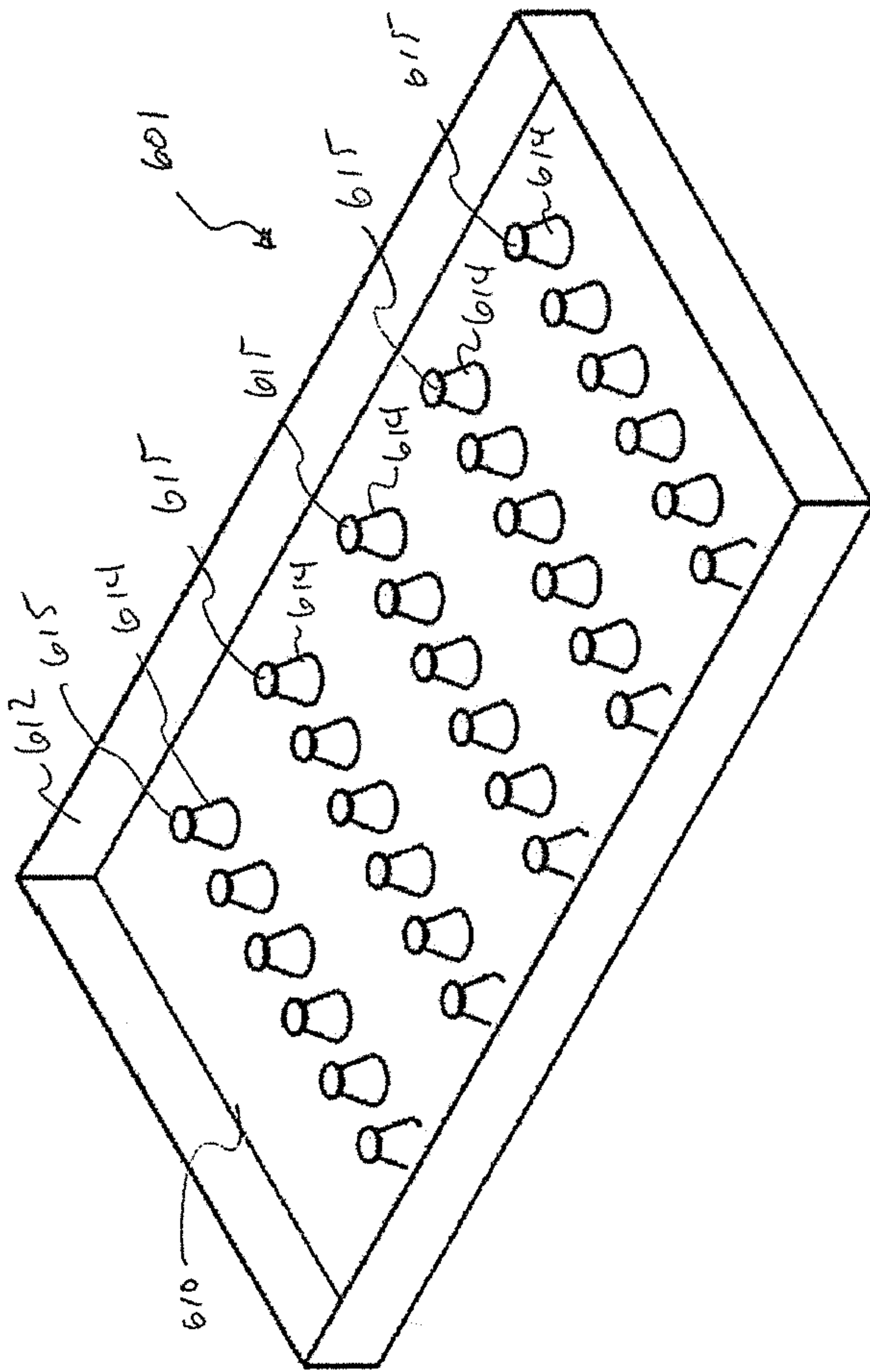

Fig. 6C

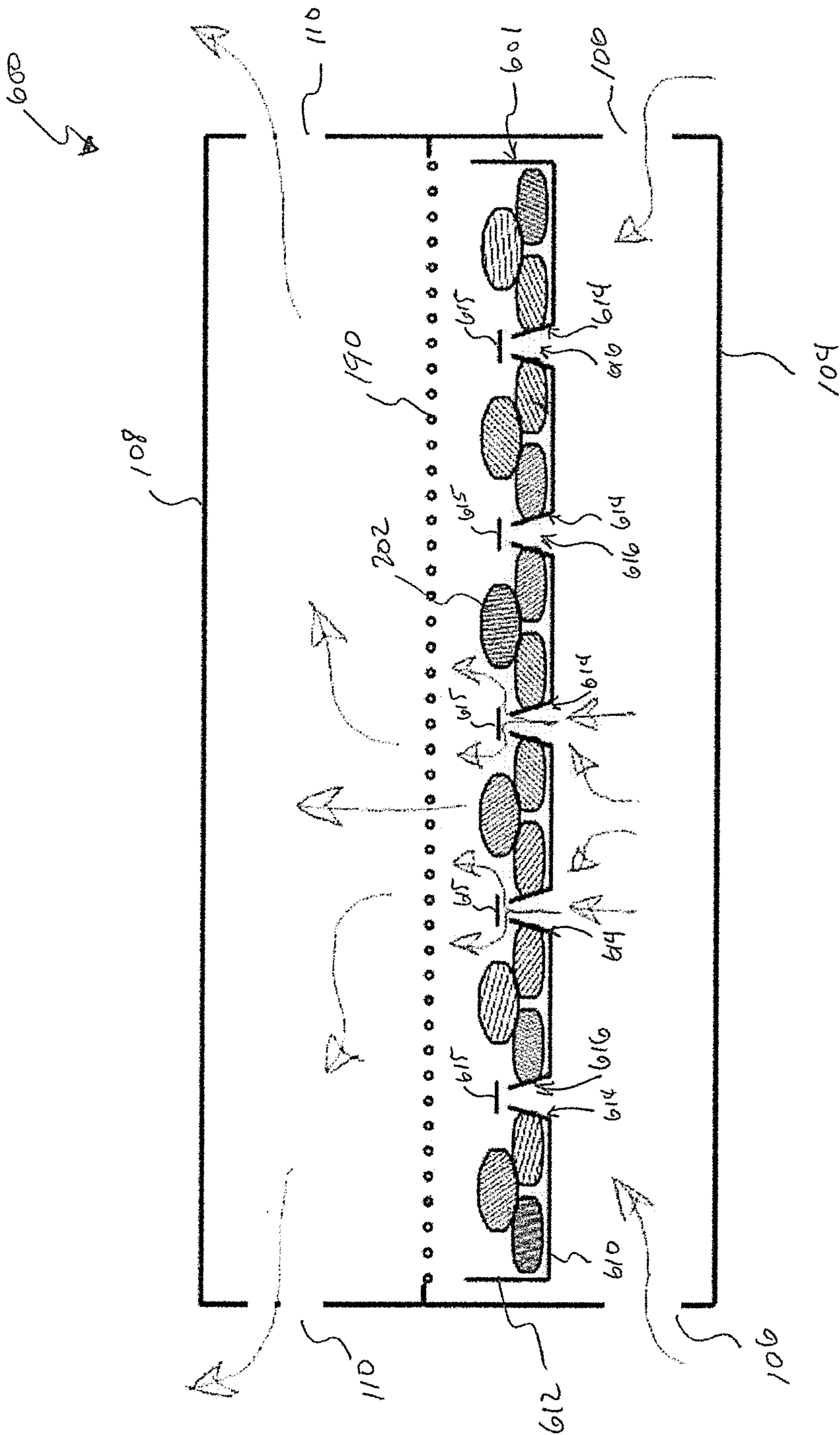

Fig. 6D

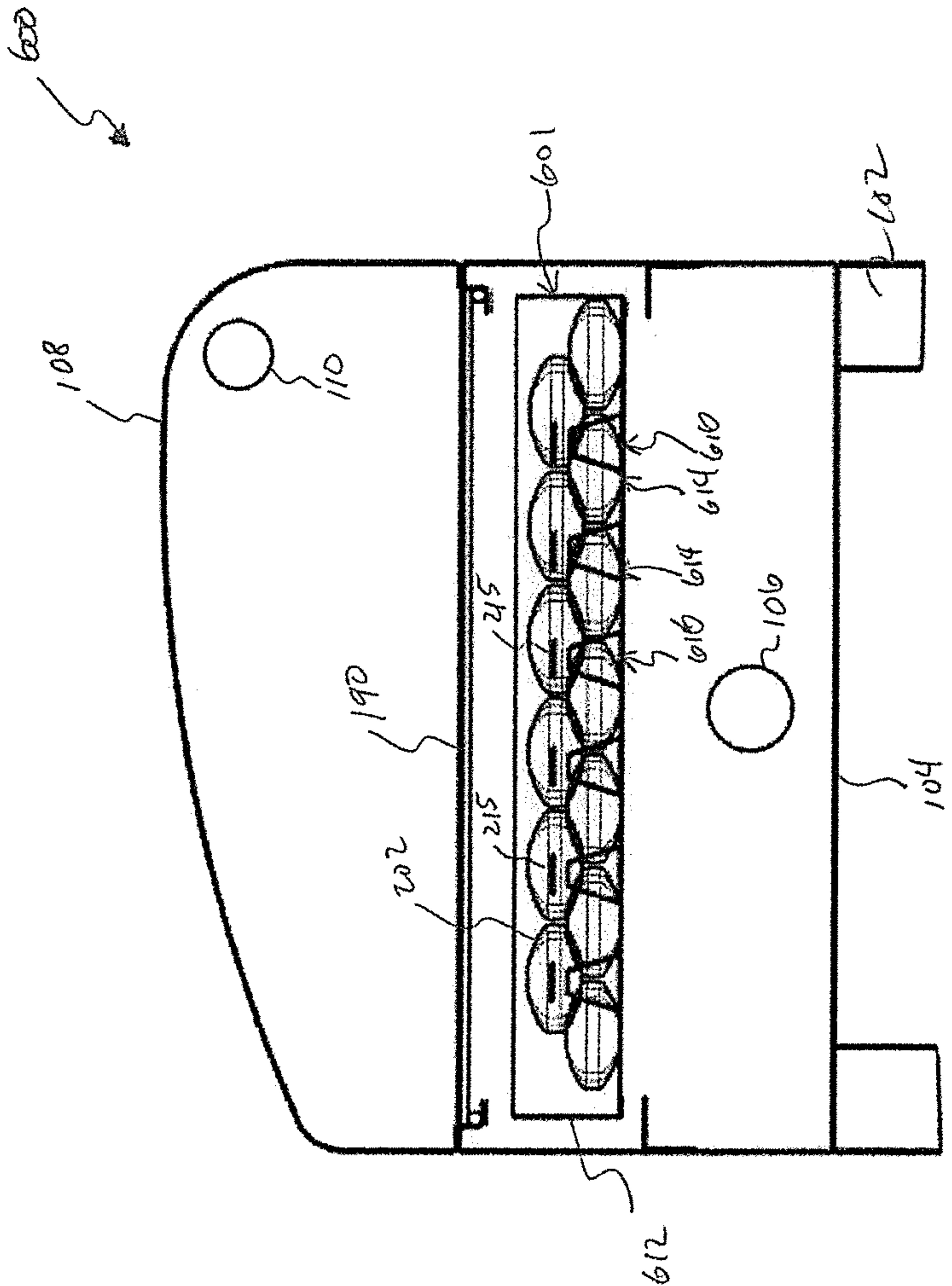

Fig. 6E

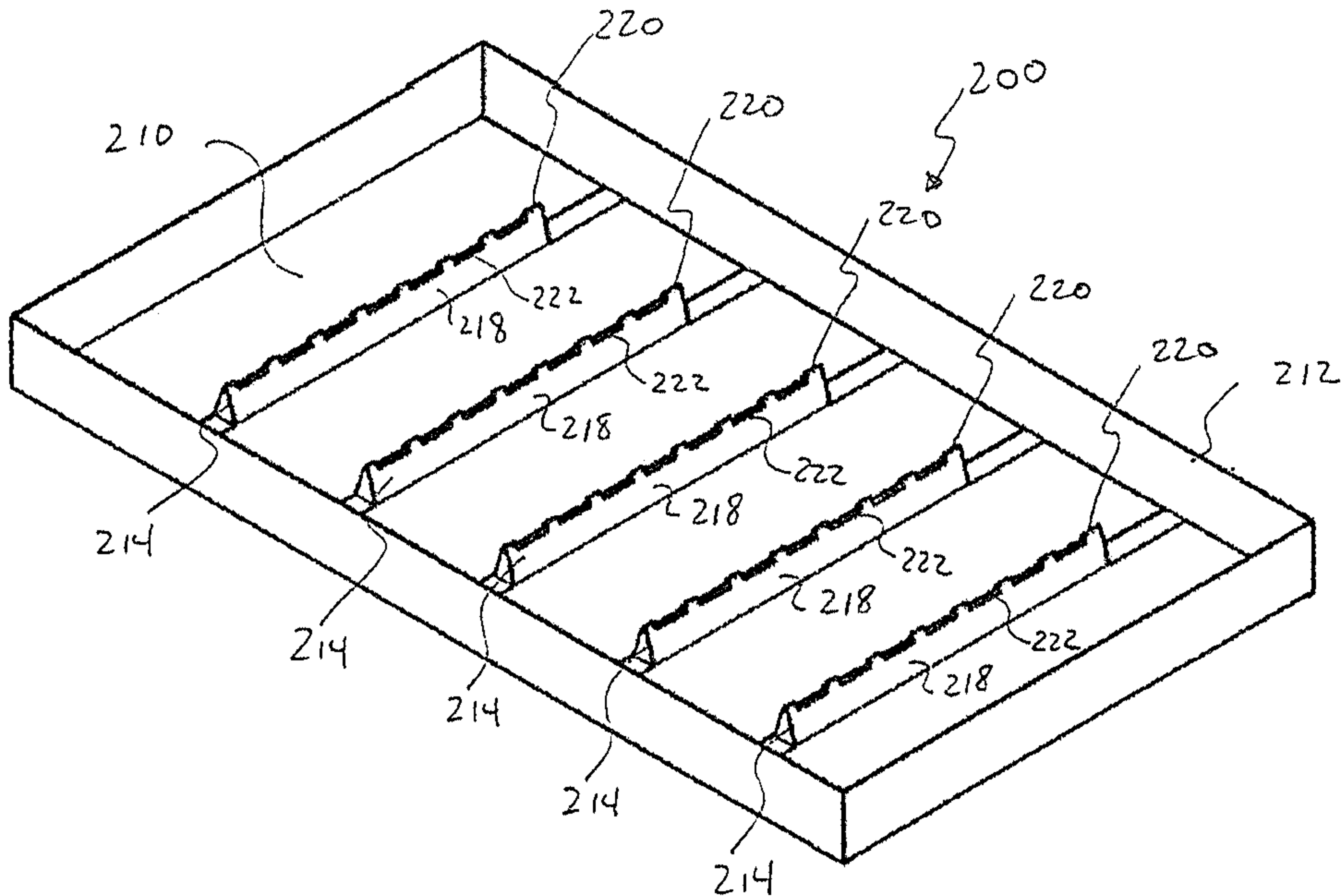

Fig. 2C