

(19) World Intellectual Property Organization
International Bureau



(43) International Publication Date
11 August 2011 (11.08.2011)

(10) International Publication Number
WO 2011/097487 A2

(51) International Patent Classification:

A61M 5/142 (2006.01) A61M 5/168 (2006.01)
B01D 19/00 (2006.01) A61M 5/44 (2006.01)
A61J 1/20 (2006.01) A61M 5/14 (2006.01)

(21) International Application Number:

PCT/US2011/023757

(22) International Filing Date:

4 February 2011 (04.02.2011)

(25) Filing Language:

English

(26) Publication Language:

English

(30) Priority Data:

61/301,957 5 February 2010 (05.02.2010) US

(71) Applicant (for all designated States except US): **DEKA PRODUCTS LIMITED PARTNERSHIP** [US/US];
340 Commercial Street, Manchester, NH 03101 (US).

(74) Agent: **TEMPLE, Michelle, Saquet**; Deka Research & Development Corp., 340 Commercial Street, Manchester, NH 03101 (US).

(81) Designated States (unless otherwise indicated, for every kind of national protection available): AE, AG, AL, AM,

AO, AT, AU, AZ, BA, BB, BG, BH, BR, BW, BY, BZ, CA, CH, CL, CN, CO, CR, CU, CZ, DE, DK, DM, DO, DZ, EC, EE, EG, ES, FI, GB, GD, GE, GH, GM, GT, HN, HR, HU, ID, IL, IN, IS, JP, KE, KG, KM, KN, KP, KR, KZ, LA, LC, LK, LR, LS, LT, LU, LY, MA, MD, ME, MG, MK, MN, MW, MX, MY, MZ, NA, NG, NI, NO, NZ, OM, PE, PG, PH, PL, PT, RO, RS, RU, SC, SD, SE, SG, SK, SL, SM, ST, SV, SY, TH, TJ, TM, TN, TR, TT, TZ, UA, UG, US, UZ, VC, VN, ZA, ZM, ZW.

(84) Designated States (unless otherwise indicated, for every kind of regional protection available): ARIPO (BW, GH, GM, KE, LR, LS, MW, MZ, NA, SD, SL, SZ, TZ, UG, ZM, ZW), Eurasian (AM, AZ, BY, KG, KZ, MD, RU, TJ, TM), European (AL, AT, BE, BG, CH, CY, CZ, DE, DK, EE, ES, FI, FR, GB, GR, HR, HU, IE, IS, IT, LT, LU, LV, MC, MK, MT, NL, NO, PL, PT, RO, RS, SE, SI, SK, SM, TR), OAPI (BF, BJ, CF, CG, CI, CM, GA, GN, GQ, GW, ML, MR, NE, SN, TD, TG).

Published:

— without international search report and to be republished upon receipt of that report (Rule 48.2(g))

(54) Title: INFUSION PUMP APPARATUS, METHOD AND SYSTEM

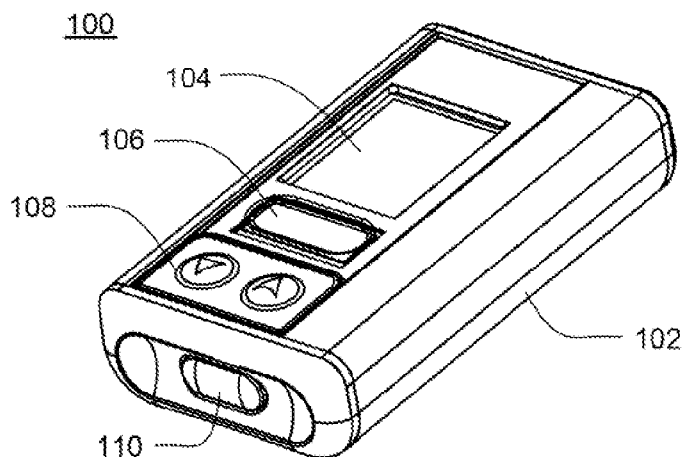

FIG. 1A

(57) Abstract: A system is disclosed. The system includes a fill adapter device including a heat exchanger which includes a heating element and a fluid pathway, the fluid pathway fluidly connected to a filling needle input, whereby fluid enters the heat exchanger through the filling needle input and flows through the fluid pathway and whereby the fluid is heated by the heating element. The system also includes a reservoir including a plunger and a plunger rod and a filling needle configured to be removably attached to the reservoir, wherein the fill adapter is configured to be attached to a vial of fluid and wherein fluid from the vial flows through the fluid pathway and is heated and loaded into the reservoir through the filling needle.



WO 2011/097487 A2

INFUSION PUMP APPARATUS, METHOD AND SYSTEM

5 CROSS REFERENCE TO RELATED APPLICATION(S)

The present application is a Non-Provisional Application which claims priority from U.S. Provisional Patent Application Serial No. 61/301,957, filed February 5, 2010 and entitled **Infusion Pump Apparatus, Method and System** (Attorney Docket No. H91), which is hereby incorporated herein by reference in its entirety.

10 TECHNICAL FIELD

The present disclosure relates to medical devices and more particularly, to an infusion pump apparatus, methods and systems.

BACKGROUND INFORMATION

15 Many potentially valuable medicines or compounds, including biologicals, are not orally active due to poor absorption, hepatic metabolism or other pharmacokinetic factors. Additionally, some therapeutic compounds, although they can be orally absorbed, are sometimes required to be administered so often it is difficult for a patient to maintain the desired schedule. In these cases, parenteral delivery is often employed or could be employed.

20 Effective parenteral routes of drug delivery, as well as other fluids and compounds, such as subcutaneous injection, intramuscular injection, and intravenous (IV) administration include puncture of the skin with a needle or stylet. Insulin is an example of a therapeutic fluid that is self-injected by millions of diabetic patients. Users of parenterally delivered drugs may benefit from a wearable device that would automatically deliver needed
25 drugs/compounds over a period of time.

To this end, there have been efforts to design portable and wearable devices for the controlled release of therapeutics. Such devices are known to have a reservoir such as a cartridge, syringe, or bag, and to be electronically controlled. These devices suffer from a number of drawbacks including the malfunction rate. Reducing the size, weight and cost of
30 these devices is also an ongoing challenge. Additionally, these devices often apply to the skin and pose the challenge of frequent re-location for application.

SUMMARY

In accordance with one aspect of the present invention, a system is disclosed. The system includes a fill adapter device including a heat exchanger which includes a heating element and a fluid pathway, the fluid pathway fluidly connected to a filling needle input, whereby fluid enters the heat exchanger through the filling needle input and flows through the fluid pathway and whereby the fluid is heated by the heating element. The system also includes a reservoir including a plunger and a plunger rod and a filling needle configured to be removably attached to the reservoir, wherein the fill adapter is configured to be attached to a vial of fluid and wherein fluid from the vial flows through the fluid pathway and is heated and loaded into the reservoir through the filling needle.

Some embodiments of this aspect of the invention may include one or more of the following. Wherein the system further includes a pump to pump fluid into the fluid pathway at a predetermined rate. Wherein the system further includes a check valve for metering fluid into the fluid pathway whereby the rate of flow of fluid through the heat exchanger is controller. Wherein the system further includes a processor for controlling the heating of the fluid according to one or more preprogrammed profiles. Wherein the system further includes wherein the filling needle input is a septum. Wherein the system further includes an air trap whereby the air trap allows air to flow out of the heat exchanger. Wherein the system further includes wherein the air trap comprising a hydrophobic filter.

In accordance with one aspect of the present invention, a fill adapter device is disclosed. The fill adapter device includes a heat exchanger including a heating element
5 and a fluid pathway, the fluid pathway fluidly connected to a filling needle input and a vial, whereby fluid from the vial enters the heat exchanger and flows through the fluid pathway and whereby the fluid is heated by the heating element.

Some embodiments of this aspect of the invention may include one or more of the following. Wherein the device further includes a pump to pump fluid into the fluid pathway at a predetermined rate. Wherein the device further includes a check valve for metering fluid into the fluid pathway whereby the rate of flow of fluid through the heat exchanger is controller. Wherein the device further includes a processor for controlling the heating of the fluid according to one or more preprogrammed profiles. Wherein the device further includes wherein the fill adapter is configured to be attached to a vial of fluid. Wherein the device further includes wherein the filling needle input is a septum. Wherein the device

further includes an air trap whereby the air trap allows air to flow out of the heat exchanger. Wherein the device further includes wherein the air trap comprising a hydrophobic filter.

In accordance with one aspect of the present invention, a method for atmospheric mitigation in an infusion pump is disclosed. The method includes a pressure sensor sending data to a pump processor at a predetermined interval, determining if the data exceeds an alarm threshold, if the data exceeds a predetermined alarm threshold, the processor
5 indicating to the user to disconnect from a cannula, determining if the data meets a predetermined safe threshold, and indicating to the user to re-connect to the cannula.

In accordance with one aspect of the present invention, an infusion pump system is disclosed. The system includes a reservoir, an active check valve located downstream from the reservoir and upstream from a cannula, a passive check valve having a cracking pressure
10 located downstream from the reservoir, and a pump processor, wherein the active check valve is opened by the pump processor for scheduled pump deliveries, wherein when fluid pressure overcomes the cracking pressure, the passive check valve opens, and fluid flows from the reservoir and through the passive check valve.

In accordance with one aspect of the present invention, an infusion pump system is disclosed. The system includes a reservoir and at least one valve downstream from the reservoir wherein at least one valve is a pressure compensation valve having a cracking
15 pressure wherein a differential pressure related to the change a altitude of the infusion pump cases the at least one valve to open.

In accordance with one aspect of the present invention, a method for atmospheric mitigation in an infusion pump is disclosed. The method includes receiving information related to a scheduled departure and a scheduled landing time, modifying the frequency of processing data related to altitude based on the information, determining, by comparing the information and the altimeter, whether a change in schedule may be occurring, alerting a user of a change of schedule, requesting updated schedule information, and modifying the
20 scheduled delivery of fluid based on the entered schedule a altimeter data.

In accordance with one aspect of the present invention, an infusion pump system is disclosed. The system includes a reservoir comprising a plunger, at least one sensor for determining the location of the plunger, and a processor configured to receive information from the at least one sensor. The processor is configured to modify the frequency of
30 determination of the location of the plunger and the processor is configured to determine the volume of fluid either siphoned into or delivered out of a reservoir and modify scheduled pump deliveries for a predetermined amount of time.

In accordance with one aspect of the present invention, a system for temperature compensation for an infusion pump is disclosed. The system includes at least one temperature sensor and at least one processor, the processor in communication with the temperature sensor, wherein the processor determines a target plunger position and, based at least upon communication from the temperature sensor, modifies the target plunger position based on the temperature sensed.

5 In accordance with one aspect of the present invention, a system for pressure mitigation for an infusion pump is disclosed. The system includes at least one pressure sensor; and a processor, wherein the pressure sensor sends data to the processor and the processor mitigates pressure changes if the pressure changes meet a preprogrammed threshold.

10 These aspects of the invention are not meant to be exclusive and other features, aspects, and advantages of the present invention will be readily apparent to those of ordinary skill in the art when read in conjunction with the appended claims and accompanying drawings.

15 BRIEF DESCRIPTION OF THE DRAWINGS

These and other features and advantages of the present invention will be better understood by reading the following detailed description, taken together with the drawings wherein:

20 FIGS. 1A-1B are front and back isometric view of an embodiment of an infusion pump;

FIGS. 1C-1E are side and front views of the infusion pump assembly of FIG. 1;

FIG. 1F is a front isometric view of the infusion pump assembly of FIG. 1;

FIG. 3 is an illustrative view of one embodiment of a remote control assembly;

FIG. 4 is a diagrammatic view of the infusion pump assembly of FIG. 1;

25 FIGS. 10A-10E depict a plurality of hook-and-loop fastener configurations according to some embodiments;

FIG. 11 is an illustration of one embodiment of a holder;

FIG. 12 is an illustration of one embodiment of a user wearing a holder;

FIG. 13 is an illustration of one embodiment of the back of a holder;

30 FIG. 14 is an illustration of one embodiment of a vial with a temperature gauge / label;

FIG. 15 is a flowchart of one embodiment of method for atmospheric pressure determination and mitigation;

FIG. 16 is an illustration of one embodiment of a passive and active check valve embodiment;

5 FIG. 17 is an illustration of a cross sectional view of one embodiment of a fill adapter;

FIG. 18 is an illustration of a vial system for maintaining a vacuum within a vial according to one embodiment;

FIG. 19 is an illustration of a vial apparatus according to one embodiment; and

Appendix A is one embodiment of a micro check valve used in some embodiments.

10

DETAILED DESCRIPTION OF THE EXEMPLARY EMBODIMENTS

Definitions

As used in this description and the accompanying claims, the following terms shall
15 have the meanings indicated, unless the context otherwise requires:

A “device” shall mean a medical device, which includes, but is not limited to, an infusion pump and/or a controller, i.e., a device for wireless control of another medical device. In some embodiments, the word “device” is used interchangeably with “pump”, “infusion pump” and/or “controller” and/or “Companion” and/or “remote controller device” and/or
20 “remote controller assembly”.

A “Companion” shall mean a device for wireless control of another medical device. In the exemplary embodiments, the Companion may also include a glucose meter/ strip reader.

An “input” of a device includes any mechanism by which a user of the device or other operator/caregiver may control a function of the device. User inputs may include mechanical
25 arrangements (e.g., switches, pushbuttons, jogwheel(s)), electrical arrangements (e.g., a slider, touch screen), wireless interfaces for communication with a remote controller (e.g., RF, infrared), acoustic interfaces (e.g., with speech recognition), computer network interfaces (e.g., USB port), and other types of interfaces.

A “button” in the context of an input such as the so-called “bolus button” discussed
30 below may be any type of user input capable of performing a desired function, and is not limited to a pushbutton, a slider, switch, touch screen or a jog wheel.

An “alarm” includes any mechanism by which an alert may be generated to a user or third party. Alarms may include audible alarms (e.g., a speaker, a buzzer, a speech generator), visual alarms (e.g., an LED, an LCD screen), tactile alarms (e.g., a vibrating element), wireless

signals (e.g., a wireless transmission to a remote controller or caretaker), or other mechanism. Alarms may be generated using multiple mechanisms simultaneously, concurrently, or in a sequence, including redundant mechanisms (e.g., two different audio alarms) or complementary mechanisms (e.g., an audio alarm, a tactile alarm, and a wireless alarm).

5 “Fluid” shall mean a substance, a liquid for example, that is capable of flowing through a flow line.

A “user” includes a person or animal who receives fluid from a fluid delivery device, whether as part of a medical treatment or otherwise, or a caregiver or third party involved in programming the device or otherwise interacting with the device to infuse fluid to another.

10 “Cannula” shall mean a disposable device capable of infusing fluid to a user. A cannula as used herein may refer to a traditional cannula or to a needle.

“Disposable” refers to a part, device, portion or other that is intended to be used for a fixed duration of time, then discarded and replaced.

“Reusable” refers to a portion that is intended to have an open-ended duration of use.

15 “Acoustic volume measurement” shall mean quantitative measurement of a relevant volume using acoustical techniques such as those described in U.S. Patent Nos. 5,349,852 and 5,641,892, which are hereby incorporated by reference herein in their entireties, as well as other techniques.

A “temperature sensor” includes any temperature determination device / mechanism
20 for measuring temperature and communicating temperature information to a controller and/ or to a pump processor. The devices described herein may include one or more temperature sensors for measuring such things as including, but not limited to, one or more of the following: user skin temperature, AVS temperature, ambient temperature, internal pump temperature, plunger temperature, drive train temperature and fluid temperatures.

25 An exemplary use of embodiments of the devices, methods and systems described here is for the delivery of insulin to people living with diabetes, but other uses include delivery of any fluid, as described above. Fluids include analgesics to those in pain, chemotherapy to cancer patients and enzymes to patients with metabolic disorders. Various therapeutic fluids may include small molecules, natural products, peptide, proteins, nucleic acids, carbohydrates,
30 nanoparticulate suspensions, and associated pharmaceutically acceptable carrier molecules. Therapeutically active molecules may be modified to improve stability in the device (e.g., by pegylation of peptides or proteins). Although illustrative embodiments herein describe drug-delivery applications, embodiments may be used for other applications including liquid dispensing of reagents for high throughput analytical measurements such as lab-on-chip

applications and capillary chromatography. For purposes of description below, terms “therapeutic”, “insulin” or “fluid” are used interchangeably, however, in other embodiments, any fluid, as described above, may be used. Thus, the device and description included herein are not limited to use with therapeutics.

5 Some embodiments of the fluid delivery device are adapted for use by people living with diabetes and/or their caregivers. Thus, in these embodiments, the devices, methods and systems work to deliver insulin which supplements or replaces the action of the person living with diabetes’ (referred to as the user) pancreatic islet beta cells. Embodiments adapted for insulin delivery seek to mimic the action of the pancreas by providing both a basal level of
10 fluid delivery as well as bolus levels of delivery. Basal levels, bolus levels and timing may be set by the user or a caregiver by using a wireless handheld user interface or directly by using a pump. Additionally, basal and/or bolus levels may be triggered or adjusted in response to the output of a glucose meter, which in the exemplary embodiments, is integral to the controller. In other embodiments, the controller additionally includes a glucose monitoring device which
15 receives data from a blood glucose sensor. In some embodiments, a bolus may be triggered by a user using a designated button or other input means located on a device, i.e., on the controller and/or on an infusion pump. In still other embodiments, the bolus or basal may be programmed or administered through a user interface located either on the fluid delivery device/infusion pump and/or on the controller.

20 With respect to the names given to screens and types of screens, as well as proper names given to various features, throughout various embodiments, these terms may vary.

 The systems and methods described herein may be used to control an infusion pump. For purposes of this description, the various embodiments of the user interface and the infusion pump may be described with reference to an insulin pump, or a pump which infuses insulin.
25 However, it should be understood that the user interface may be on an infusion pump and/or on a controller. Additionally, where the description pertains to an infusion pump “screen”, this “screen” may also appear on a controller, or may appear on a controller in lieu of a pump.

 Infusion pumps contemplated by this description include a pump which may pump any fluid, including, but not limited to, a therapeutic fluid, which includes, but is not limited to,
30 insulin. Thus, where this description describes the exemplary embodiment as pertaining to insulin, this is meant merely for descriptive purpose only as the device is not intended to be limited to insulin. Other fluids are also contemplated. In some embodiments, the methods, systems and devices described herein may be used in conjunction with insulin “pens” and/or fluid delivery “pens”, which are known in the art.

The infusion pump may be any infusion pump, for example, but not limited to, the pump devices shown and described with respect to FIGS. 1A-1F and those incorporated herein by reference, and include, but are not limited to, those incorporated herein by reference. In the various exemplary embodiments, the infusion pump is a syringe-pump, i.e., the fluid is
5 pumped or delivered to the user when a plunger advances in a syringe, pushing the fluid inside the syringe into a cannula. Where the cannula is connected to a user (i.e., the cannula is within the user's subcutaneous region) the fluid is delivered subcutaneously to the user.

In the exemplary embodiment, the infusion pump includes hardware for wireless RF communication with a controller. However, in various embodiments, the infusion pump may
10 be any infusion pump. Referring to FIGS. 1A-1F and 2A-2D, in some exemplary embodiments, the infusion pump may include a display assembly 104, however, in other exemplary embodiments, such as those shown in FIGS. 2A-2D, the infusion pump may not include a display assembly. In these embodiments, a display assembly which may be similar to the one shown in FIGS. 1A, 1D and 1F, or may be larger or smaller, is included on a
15 controller or companion device. An embodiment of the controller or companion device is shown in FIG. 3.

Referring to FIGS. 1A-1F, an embodiment of an infusion pump assembly 100 that may be housed within enclosure assembly 102 is shown. Infusion pump assembly 100 may include a display system 104 that may be visible through the enclosure assembly 102. One or more
20 switch assemblies / input devices 106, 108, 110 may be positioned about various portions of the enclosure assembly 102. The enclosure assembly 102 may include infusion port assembly 112 to which cannula assembly 114 may be releasably coupled. A removable cover assembly 116 may allow access to a power supply cavity 118 (shown in phantom on FIG. 1D).

Referring to the infusion pump assemblies shown in FIG. 1A-1F, infusion pump
25 assembly 100 may include processing logic (not shown), which may be referred to as the pump processor, that executes one or more processes that may be required for infusion pump assembly 100 to operate properly. Processing logic may include one or more microprocessors (not shown), one or more input / output controllers (not shown), and cache memory devices (not shown). One or more data buses and/or memory buses may be used to interconnect
30 processing logic with one or more subsystems. In some embodiments, at least one of the subsystems shown in FIG. 4 is also included in the embodiment of the infusion pump assembly 200 shown in FIGS. 2A-2D.

Referring now to FIGS. 1A-1F and FIG. 4, examples of the subsystems interconnected with processing logic 400 may include but are not limited to memory system 402, input system

404, display system 406, vibration system 408, audio system 410 motor assembly 416, force sensor 412, temperature sensor (not shown) and displacement detection device 418 (which may be referred to as a device to determine and/or detect the distance the plunger has moved with respect to the syringe barrel/syringe). Infusion pump assembly 100 may include primary
5 power supply 420 (e.g. a battery) configured to be removable installable within power supply cavity 118 and to provide electrical power to at least a portion of processing logic 400 and one or more of the subsystems (e.g., memory system 402, input system 404, display system 406, vibration system 408, audio system 410, motor assembly 416, force sensor 412, and displacement detection device 418).

10 Infusion pump assembly 100 may include reservoir assembly 430 configured to contain infusible fluid 422. In some embodiments, reservoir assembly 430 may be a reservoir assembly similar to that described in U.S. Patent No. 7,498,563, issued March 3, 2009 and entitled Optical Displacement Sensor for Infusion Devices (Attorney Docket No. D78), which is herein incorporated by reference in its entirety, and/or as described in U.S. Patent No.
15 7,306,578, issued December 11, 2007 and entitled Loading Mechanism for Infusion Pump (Attorney Docket No. C54); PCT Application Serial No. PCT/US2009/060158, filed October 9, 2009 and entitled Infusion Pump Assembly, now Publication No. WO 2010/042814, published April 15, 2010 (Attorney Docket No. F51WO); and U.S. Patent Application Serial No.12/249,882, filed October 10, 2008 and entitled Infusion Pump Assembly, now U.S.
20 Publication No. US-2010-0094222, published April 15, 2010 (Attorney Docket No. F51), all of which are hereby incorporated herein in their entireties. In other embodiments, the reservoir assembly may be any assembly in which fluid may be acted upon such that at least a portion of the fluid may flow out of the reservoir assembly, for example, the reservoir assembly, in various embodiments, may include but is not limited to: a barrel with a plunger, a
25 barrel with a plunger connected to a plunger rod, a cassette and/or a container at least partially constructed of a flexible membrane.

Plunger assembly 424 may be configured to displace infusible fluid 422 from reservoir assembly 430 through cannula assembly 450 (which may be coupled to infusion pump assembly 100 via infusion port assembly 424) so that infusible fluid 422 may be delivered to
30 user 454. In this particular embodiment, plunger assembly 424 is shown to be displaceable by partial nut assembly 426, which may engage lead screw assembly 428 that may be rotatable by motor assembly 416 in response to signals received from processing logic 400. In this particular embodiment, the combination of motor assembly 416, plunger assembly 424, partial nut assembly 426, and lead screw assembly 428 may form a pump assembly that effectuates

the dispensing of infusible fluid 422 contained within reservoir assembly 430. An example of partial nut assembly 426 may include but is not limited to a nut assembly that is configured to wrap around lead screw assembly 426 by e.g., 30 degrees. In some embodiments, the pump assembly may be similar to one described in U.S. Patent No. 7,306,578, issued December 11, 2007 and entitled Loading Mechanism for Infusion Pump (Attorney Docket No. C54); U.S. Patent Application Serial No. 12/249,882, filed October 10, 2008 and entitled Infusion Pump Assembly, now U.S. Publication No. US-2010-0094222, published April 15, 2010 (Attorney Docket No. F51); and U.S. Patent Application Serial No. 12/249,891, filed October 10, 2008 and entitled Infusion Pump Assembly, now U.S. Publication No. US-2009-0099523 published April 16, 2009 (Attorney Docket No. G46), all of which are herein incorporated by reference in their entireties.

USER INTERFACE

Throughout this description, screens may be referenced with respect to the “pump” or “Companion” or “Controller”. However, in various embodiments, a similar screen or a similar method may be accomplished on another device. For example, where the screen or method is referenced with respect to the “pump”, a similarly functional screen or method may be used on the “Companion” or “Controller” in other embodiments. As this description includes embodiments related to both pumps having displays and pumps having no displays, it should be evident that where the embodiment includes an infusion pump without a display, any screens will be visible on a Companion or Controller. Similarly, where a method requires an interaction between the user and the pump, the interaction may be accomplished via a switch assembly on the pump where the pump is an infusion pump without a display.

Processing logic which in some embodiments, includes at least one element as shown in described with respect to FIG. 4, is used to receive inputs from a user or caregiver. The user or caregiver uses one or more input devices or assemblies, including but not limited to, one or more of the following: button / switch assembly, slider assemblies, including, but not limited to, capacitive sliders (which may include, for example, including but not limited to any slider described in U.S. Patent Application Serial No. 11/999,268, filed December 4, 2007 and entitled Medical Device Including a Slider Assembly, now U.S. Publication No. US-2008-0177900, published July 24, 2008 (Attorney Docket No. F14), which is hereby incorporated herein by reference in its entirety, jog wheel and/or touch screen. The infusion device additionally received inputs from internal systems, including but not limited to occlusion detection process 438, confirmation process 440, volume measurement technology (e.g., acoustic volume sensing). Using these inputs, the infusion device produces outputs, for

example including, but not limited to, infusion fluid delivery to the user or comments, alerts, alarms or warnings to the user. The inputs are thus either directly from the user to the pump, directly from the pump systems to the processing logic, or from another device, e.g., a remote controller device (described in more detail below), to the pump. The user or caregiver
5 interaction experience thus includes, but is not limited to, one or more of the following: interaction with a display (either on the infusion pump device itself or a remote controller device or both), which includes but is not limited to, reading/seeing text and/or graphics on a display, direct interaction with a display, for example, through a touch screen, interaction with one or more buttons, sliders, jog wheels, one or more glucose strip readers, and sensing either
10 through touch sensation or audio, one or more vibration motors, and/or an audio system. Thus, the term "user interface" is used to encompass all of the systems and methods a user or caregiver interacts with the infusion pump, to control the infusion pump.

Referring now to FIG. 3, in some embodiments of the infusion pump system, the infusion pump may be remotely controlled using a remote controller assembly 300, also
15 referred to as a controller or a companion. Remote control assembly 300 may include all, or a portion of, the functionality of the infusion pump assembly shown in FIGS. 1A-1F, itself. Thus, in some exemplary embodiments of the above-described infusion pump assembly, the infusion pump assembly (not shown, see FIGS. 1A-1F, amongst other FIGS.) may be configured via remote control assembly 300. In these particular embodiments, the infusion
20 pump assembly may include telemetry circuitry (not shown) that allows for communication (e.g., wired or wireless) between the infusion pump assembly and e.g., remote control assembly 300, thus allowing remote control assembly 300 to remotely control infusion pump assembly 100. Remote control assembly 300 (which may also include telemetry circuitry (not shown) and may be capable of communicating with infusion pump assembly) may include
25 display assembly 302 and an input assembly, which may include one or more of the following: an input control device (such as jog wheel 306, slider assembly 310, or another conventional mode for input into a device), and switch assemblies 304, 308. Thus, although remote control assembly 300 as shown in FIG. 3 includes jog wheel 306 and slider assembly 310, some
30 embodiments may include only one of either jog wheel 306 or slider assembly 310, or another conventional mode for input into a device. In embodiments having jog wheel 306, jog wheel 306 may include a wheel, ring, knob, or the like, that may be coupled to a rotary encoder, or other rotary transducer, for providing a control signal based upon, at least in part, movement of the wheel, ring, knob, or the like.

Remote control assembly 300 may include the ability to pre-program basal rates, bolus alarms, delivery limitations, and allow the user to view history and to establish user preferences. Remote control assembly 300 may also include a glucose strip reader 312.

5 During use, remote control assembly 300 may provide instructions to the infusion pump assembly via a wireless communication channel established between remote control assembly 300 and the infusion pump assembly. Accordingly, the user may use remote control assembly 300 to program / configure the infusion pump assembly. Some or all of the communication between remote control assembly 300 and the infusion pump assembly may be encrypted to provide an enhanced level of security.

10 In the exemplary embodiments of the user interface, the user interface may require user confirmation and user input. The exemplary embodiments of the user interface are centered on ensuring the user knows the effect of various interactions on the pump. Many examples will be presented throughout this description of the pump communicating the result of the user's actions to the user. These features ensure the user understands their actions and therefore,
15 imparts greater safety onto the user. One such example is throughout the exemplary embodiment of the user interface, where the user presses the back button on a screen after a value has been changed, the user interface displays the Cancel Changes confirmation screen, as shown in FIG. 6. If the user selects "Yes", the user interface discards any pending changes, closes the confirmation screen and goes back to the previous screen (i.e., the screen previous to
20 the screen where the user pressed the Back button). When the action selection is "No", on the "Cancel Changes?" confirmation screen, the user presses the enter button or other depending on the embodiment, and the user interface closes the confirmation screen and returns to the screen with pending changes. This feature prevents the outcome where the user assumes the changes have been implemented, but in fact, they have not been. Thus, this feature prevents
25 that circumstance and ensures the user understands that the changes have not been implemented.

TEMPERATURE

In various embodiments of the infusion pump, the user may wear the infusion pump either attached to a belt, attached to another article or clothing or a garment such that the device
30 is worn on the body, or, in some embodiments, attached to an undergarment, in a pocket or, in some embodiments, attached to the skin of the user. The user generally wears the infusion pump as close to twenty-four (24) hours a day as possible, and in some cases, removing the device for short periods of time, for example, but not limited to, during an MRI or other treatment that may effect the device and/or while showering/bathing. Thus, during the normal

course of the user's wearing the infusion pump, the infusion pump may be exposed to various temperatures, including, temperature swings, which may include positive temperature swings and/or negative temperature swings. These temperature swings may be the result of the user stepping out of doors, into a cold room, into a hot room and/or under a blanket or other warming agent.

The fluid contained in the reservoir while in the pump, which, as discussed above, may include, but is not limited to insulin, has a thermal expansion coefficient which may be referred to as a general volumetric thermal expansion coefficient. Thus, during a temperature swing/differential/change, whether positive or negative, the fluid, or insulin, will expand or contract. Various factors may contribute to the expansion or contraction of the fluid including but not limited to the rate of change of the temperature. Thus, in some embodiments, the amount of expansion or contraction may be a function of the temperature.

Additionally, in various embodiments of the various embodiments of the devices described, the components of the pumps also have thermal expansion coefficients. These thermal expansion coefficients may vary depending on the material. Thus, where the various components are made from different materials, the thermal expansion coefficients may vary.

In some embodiments, a change in temperature may affect a thermal expansion or thermal contraction of the fluid and/or one or more components of the infusion pump. For example, but not limited to, an increase in temperature may cause an increase in the diameter of the reservoir / syringe 430 (for illustration only, please refer to FIG. 4). This may be because the relative thermal expansion of the syringe compared with the fluid governs whether fluid is delivered or pulled back. Thus, this in turn may cause any fluid/insulin in the cannula 450 to flow backwards, towards the reservoir 430. In this case, a volume of fluid/insulin is pulled back into the reservoir. Thus, a subsequent request for a delivery by processing logic 400 may only result in this retracted volume being delivered to the user. Thus, a volume of fluid/insulin (the retracted volume) has not been delivered to the user without request or knowledge by the user. Another example includes temperature decrease. In some embodiments, a temperature decrease may cause the reservoir 430 to decrease in diameter, causing fluid/insulin to flow to the cannula 450. Thus, an unintended bolus volume is delivered to this user. In this case, fluid/insulin has been delivered to the user without request or knowledge by the user.

Thus, in the first example, the user may receive less fluid/insulin than is required or requested and thus, may experience hyperglycemia. In the second example, the user may receive more fluid/insulin than is required or requested and thus, may experience

hypoglycemia. In either example, the user receives a fluid/insulin volume that is not the same as the requested or programmed therapy and is not notified of the disparity.

In these examples, the reservoir is assumed to be a cylinder. Below is a mathematical model of the change in volume of a cylinder (assuming a constant coefficient of linear expansion, α). This is a model for explanation purposes. Additional mathematical models may be determined to accommodate additional assumptions, for example, a shape other than a cylinder, or a syringe with a movable plunger.

$$\Delta V = V(3\alpha\Delta T + 3\alpha^2\Delta T^2 + \alpha^3\Delta T^3) \text{ [EQ\#1]}$$

Which may be simplified assuming $\alpha\Delta T \ll 1$ to:

10

$$\frac{\Delta V}{V} \approx 3\alpha\Delta T \text{ [EQ\#2]}$$

Thus, the volume change of a cylinder made from polypropylene where the temperature changes from 30 C to 10 C for polypropylene, which is a material with linear coefficient of linear expansion $\alpha = 86 \times 10^{-6} \frac{cm}{cm \cdot K}$, would be:

15

$$\frac{\Delta V}{V} \approx 3 \left(86 \times 10^{-6} \frac{cm}{cm \cdot K} \right) (20K) = 0.52\% \text{ [EQ\#3]}$$

The change in specific volume for water between 30 C and 10 C is about 0.40%. The difference between the two (about 0.12%) applied to a 3 cc syringe or reservoir would be about 3.6 μL . However, in addition, the syringe plunger may move in response to the thermal expansion depending on the plunger material and the relationship of the syringe in the pump (e.g., the design of the syringe retention in the pump).

Therefore, there may be a desire to minimize the effect of temperature on the delivery of fluid. Thus, it may be desired to limit or minimize, and / or characterize, the thermal expansion of the fluid and/or one or more of the components of the infusion pump. The systems, methods and apparatus described to minimize the effect of temperature on the thermal expansion of the fluid and/or one of more of the components of the infusion pump may include one or more of the following exemplary embodiments.

In some embodiments, selection of materials with predictable and favorable thermal expansion coefficients may minimize the potential under and over delivery of fluids as discussed above. In some embodiments, the syringe material, for example, may be selected to match the thermal expansion of the fluid. For example, the linear expansion coefficient for water at about 20 C is about:

30

$$68.9 \times 10^{-6} \frac{cm}{cm \cdot K} \text{ [EQ#4]}$$

Thus, the syringe material may be selected to have an expansion coefficient close to this value. For example, a blend of polycarbonate and acrylonitrile butadiene styrene (also referred to as "ABS") could be used to match the thermal expansion coefficient of the fluid.

5 In some embodiments, other plastics, for example, but not limited to, polycarbonate, may be close to the correct expansion coefficient such that the volume delivered by the syringe pump due to the expected temperature change is minimal and/or acceptable. In some embodiments, the plastic or material selected may be tailored to the slope of the thermal expansion of the fluid.

10 In some embodiments, the material of the plunger and / or the plunger rod may be selected to thermally differentially compensate for the change in temperature. In some embodiments, the materials for the syringe, plunger and plunger rod may be selected to thermally differentially compensate for the change in temperature. Also, or in addition to, in some embodiments, the material of one or more components of the drive train, or any other
15 component of the infusion pump, may be selected to thermally differentially compensate for the change in temperature.

In some embodiments, the materials for any one or more infusion pump components may be selected to have an opposite thermal coefficient, or a thermally compensating material to minimize the thermal expansion effects of the temperature. For example, in higher
20 temperatures, where the infusion pumps syringe expands, the flow of fluid may be negative. In some embodiments, at least one component of the drive train may have a negative thermal constant, thus, having the opposite thermal coefficient. Thus, upon a temperature increase, the syringe does not experience a change in volume.

In some embodiments, the use of a material which may undergo a phase change during
25 a temperature change event may minimize the effect of the temperature differential/change on the infusion pump. For example, in some embodiments, the plunger may include a predetermined volume of wax, thus, as the temperature increases, the length or position may increase due to the phase change of the wax. Additional wax features may be added in some embodiments to prevent flow. In some embodiments, a wax feature may be added to move the
30 plunger forward a (predetermined) distance such that the resulting change in the volume is equal to the square root of the diameter of the plunger. Thus, in some embodiments, the use of a material which undergoes a phase change in response to temperature/temperature change/differential may be used to compensate for the change of volume of the syringe due to

a temperature change. In some embodiments, the material which undergoes a phase change in response to a temperature change may absorb the energy of the thermal differential, thus, for example, where the temperature is increasing, rather than rising the temperature of the infusion pump, the wax, or other phase change material, may melt the wax/phase change material, thus, acting as an energy sink and absorbing the heat.

In some embodiments, the syringe may be constrained in such a way that a change in temperature may cause the plunger to be advanced or withdrawn to compensate for the volume change of the syringe. For example, in some embodiments, the syringe may be held in a metal case, the metals that may be used include but are not limited to, steel, aluminum, and / or any metal with a low coefficient of thermal expansion, which may include, but is not limited to, FeNi36, also known as INVAR®. The plunger may be made from a material that has a high coefficient of thermal expansion. Thus, in this example, a decrease in temperature may cause the syringe plunger to be withdrawn as the diameter of the syringe barrel is decreasing. Thus, balancing these effects, the change in the total volume may be minimized.

15 **Characterization and Controls Compensation**

In some embodiments, characterizing the effect of a change in temperature on the volume of fluid pumped by the infusion device may be completed. In this embodiment, the pump may be subjected to temperature variation (i.e., both positive and negative) and the corresponding response by the infusion pump may be recorded. The characterization may include, but is not limited to, varying rates of change (i.e., 1 degree Celsius per minute, and whether positive and negative, etc), total temperature variation (e.g., 10 degrees Celsius, 5 degrees Celsius, etc), and / or position of syringe plunger.

The infusion pump may include one or more devices and/or components and/or systems to determine the temperature. In some embodiments, the infusion pump may include one or more thermistors or other temperature sensors to determine the temperature. However, in other embodiments, various methods and/or devices and/or systems to determine the temperature, either directly or indirectly, may be used, including, but not limited to, one or more of the following: at least one resistance temperature device (RTD) and/or at least one non-contact infrared device (non-contact IR). The location of the one or more thermistors and/or temperature determination devices may vary. The locations of one or more of the thermistors and/or temperature determination devices may include, but is not limited to, the drive screw, any location on the drive train, on the syringe barrel, including but not limited to, printed on the syringe barrel, the plunger and / or, the printed circuit board. In various embodiments, the one or more thermistor(s) and/or temperature determination devices location

may be any where away from the heat sources that would render a potentially false reading. In some embodiments, the one or more thermistors may determine the temperature of one or more locations, including, but not limited to, inside of the syringe, the outside of the syringe, the inside of the pump, and / or the outside of the pump. Various controls may be determined
5 based on a temperature model in any one or more of these locations. Thus, in some embodiments, the characterization may be made by taking temperature readings both within the syringe and outside of the syringe. In other embodiments, the characterization may be performed by taking temperature readings from outside the pump and inside the pump. In the various embodiments, the one or more thermistors and/or temperature determination devices
10 are preferably placed in the same location on the pump for use by the user as they were during the characterization.

In some embodiments, the characterization may be completed by measuring the volume of fluid delivered as a function of temperature. In some embodiments, this may be accomplished by using a thermal chamber and an infusion set / cannula connected to the
15 reservoir / syringe delivering fluid to a precision scale. However, in other embodiments, this may be completed by using a thermal chamber and an infusion set/cannula connected to the reservoir/syringe delivering fluid, and following, determining the position of the plunger inside the reservoir to determine the total volume of fluid delivered.

In some embodiments, in practice, the temperature of the pump (in one or more
20 locations and / or taken by one or more thermistors) may be measured and the target position of the plunger may vary as a function of temperature to compensate for the thermal expansion of the syringe and/ or the plunger. The thermal expansion reading may be determined by referencing the characterization data, as discussed above. Thus, in some embodiments, the target position may be modified based on a look-up table or function approximation of the
25 volume change of the syringe with temperature.

In some embodiments, the infusion pump delivers fluid either as a basal or a bolus delivery, and/or a variety thereof. The basal delivery is a programmed rate or volume per hour. The infusion pump delivers a volume of fluid at preset intervals for preset durations of time. The infusion pump may also deliver bolus volumes. A bolus is a requested volume of fluid
30 delivered immediately, i.e., at the time the request is made. One embodiment of the bolus and basal delivery methods is described in PCT Application Serial No. PCT/US2009/060158, filed October 9, 2009 and entitled Infusion Pump Assembly, now Publication No. WO 2010/042814, published April 15, 2010 (Attorney Docket No. F51WO); and U.S. Patent Application Serial No.12/249,882, filed October 10, 2008 and entitled Infusion Pump

Assembly, now U.S. Publication No. US-2010-0094222, published April 15, 2010 and entitled Infusion Pump Assembly (Attorney Docket No. F51), both of which are hereby incorporated herein by reference in their entireties. Further, in some embodiments, for example, in the embodiment described in U.S. Patent No. 7,498,563, issued March 3, 2009 and entitled Optical
 5 Displacement Sensor for Infusion Devices (Attorney Docket No. D78), which is herein incorporated by reference in its entirety, the infusion pump may determine the distance the plunger must move to deliver a volume of fluid, e.g., a basal volume or a bolus volume. Thus, in some embodiments of the infusion pump system, the infusion pump may confirm the distance the plunger moved during a delivery using an optical displacement sensor. In some
 10 embodiments, the infusion pump determines the number of motor encoder counts per delivery and confirms movements of the plunger.

However, in various embodiments, the delivery method includes a determination of the distance the plunger should move (which may be referred to as the target plunger position) to deliver the desired/target volume. As discussed above, this may be done by determining the
 15 number of motor encoder steps, and in other embodiments, may be another method. Regardless, the infusion pump makes a determination of plunger distance movement.

One example of the characterization and controls compensation method is as follows. The first step may be to characterize the volume delivered as the temperature changes. This volume may be a function of the amount of fluid contained in the syringe, call this V , and, due
 20 to variations in the thermal expansion properties of plastics and liquids / fluids, also, a function of the temperature, call this T . A function, $\beta(T)$, may be found empirically that related the volume change to the temperature change.

$$\beta(T) = \frac{1}{V} \frac{\Delta V}{\Delta T} \text{ [EQ#5]}$$

The coefficient $\beta(T)$ may be approximated as a constant, found as a function of
 25 temperature (as shown above) or possible found as a function of both temperature and plunger position $\beta(T, x)$.

Next, the target plunger position may be determined and adjusted. The target position, x , may be adjusted based on the following formula:

$$\Delta x = \frac{\beta(T)V}{\frac{\pi}{4}D^2} \Delta T \text{ [EQ#6]}$$

Where D is the plunger diameter. If we substitute in $V = \frac{\pi}{4} D^2 x$ (assuming that $x = 0$ where the plunger has reached the end of travel and displaced all of the fluid in the syringe) then the relationship may be simplified to:

$$\Delta x = \beta(T) x \Delta T \text{ [EQ#7]}$$

5 In various embodiments, this correction may be performed in different ways, including, but not limited to, the following. In some embodiments, the correction may be done by delivering on an interval which may be more frequent than the basal delivery interval, which may be, but is not limited to, one delivery every e.g., 3 minutes, but in other embodiments, may be more frequent or less frequent. Further, the position of the syringe may be adjusted
10 based on the temperature change, maintaining a zero net volume delivered between regular deliveries, e.g., basal and / or bolus deliveries. In some embodiments, this may be used for low basal rates, where the thermally driven volume may exceed the regularly scheduled basal delivery. This may, however, in some embodiments, require reversing the syringe direction to prevent delivery.

15 Another embodiment may include applying the correction when the fluid / insulin is scheduled for delivery. Thus, the target plunger position may be corrected based on the measured temperature change and estimated thermally-driven volume delivery. In some of these embodiments, the correction may be limited such that the plunger may only be driven in one direction.

20 In some embodiments, modeling may vary, and an assumption may be made with respect to both length and diameter of the syringe. In addition, assumption may be made regarding the effect of temperature on the thermal expansion coefficient of one or more components of the infusion pump, including, but not limited to, the drive train, plunger, plunger rod, infusion pump housing, and cannula.

25 In some embodiments, adjusting the plunger target may include adjusting the target so that it is closer to the exit of the syringe, or further away from the exit of the syringe. In some embodiments, the plunger advancement may be modified. In other embodiments, the plunger may be driven backwards to compensate for temperature. However, in some embodiments, depending on the infusion pump, it may be desired to limit adjustment to closer to the exit of
30 the syringe. This may be due to the potential for backlash.

In some embodiments, a temperature dependant basal rate may be preprogrammed to the pump for temperature compensation. In these examples, the pump processor receives data from at least one temperature sensor. If the temperature data indicates that the temperature is

such, or that the rate of change of temperature is such, that an adjustment should be made, the processor may signal to alter the preprogrammed basal rate. In some embodiments, this alteration may be either an additional or a decrease of the basal rate by a preset percentage, for example, an increase of 30% or a decrease of 15%. Of course, these are only examples, and in
5 these embodiments, the preset alterations may be determined to be different from those stated.

In some embodiments, the infusion pump may include at least one temperature sensor and at least one optical sensor. In some embodiments, the optical sensor may be used to determine that the plunger advanced. In some embodiments, the distance of advancement may also be determined. In some embodiments, a small reflective optical sensor (hereinafter
10 "optical sensor") that fits into the form factor of the infusion pump hardware is used. The optical sensor has a sensing range that overlaps with the plunger displacements. In the exemplary embodiment any optical sensor may be used, including, but not limited to a Sharp GP2S60, manufactured by Sharp Electronics Corporation which is a U.S. subsidiary of Sharp Corporation of Osaka, Japan. This optical sensor contains an infra red emitting
15 diode and infra red sensing detector in a single package. Light from the emitter is unfocused and bounces off the sensing surface, some of which makes it back to the detector resulting in the sensed intensity of light that varies as a function of distance/angle to the reflector. In some embodiments, the sensor is placed such that the reflective surface is the plunger.

20 In some embodiments, an optical sensor may be used to determine the level of fluid in the syringe / reservoir. This information may be used to determine whether the plunger rod has advanced. Together with the temperature sensor information, this may provide added data / information to determine a temperature dependant change.

In some embodiments of the infusion pump system, including those embodiments
25 disclosed and described in U.S. Patent No. 7,498,563, issued March 3, 2009 and entitled Optical Displacement Sensor for Infusion Devices (Attorney Docket No. D78); PCT Application Serial No. PCT/US2009/060158, filed October 9, 2009 and entitled Infusion Pump Assembly, now Publication No. WO 2010/042814, published April 15, 2010 (Attorney Docket No. F51WO); and U.S. Patent Application Serial No. 12/249,882, filed October 10, 2008 and
30 entitled Infusion Pump Assembly, now U.S. Publication No. US-2010-0094222, published April 15, 2010 and entitled Infusion Pump Assembly (Attorney Docket No. F51), all of which are hereby incorporated herein by reference in their entireties, the infusion pump may include an optical displacement sensor. This sensor may be used to determine whether the plunger rod has advanced, either forward or backwards, and the distance of the advancement. Using

this displacement information, together with the information from the one or more temperature sensors, the effect of the temperature change on the plunger may be determined. In turn, this determination may increase the accuracy of controls used to compensate for a temperature change. This may include, but is not limited to, decreasing
5 the amount of fluid delivered due to a sensed forward movement and / or increasing the amount of fluid delivered due to a sensed backwards movement. In either case, the increase and/or decrease of the basal rate and/or amount and/or the amount of bolus (for example, by a percentage of the amount intended) is by a predetermined amount and for a predetermined time.

10 In some embodiments, the infusion pump system may include a system and/or method for adjusting the basal rate and /or bolus amount based on a temperature change. Thus, in various embodiments, where the system determines that a threshold temperature change, either up or down, has occurred, the system may automatically, and/or by request and/or confirmation by the user, enter a mode having a limited period, e.g., a flat pre-set
15 limited time period, e.g., 20 minutes, and/or in some embodiments, the mode may continue until the temperature change threshold is no longer applicable. In some embodiments, where, for example, a decreasing temperature gradient is a primary concern, the infusion pump processor may be pre-programmed with a "decreasing gradient" mode, and the infusion pump may purposefully under deliver in this mode, i.e., an automatic percentage
20 decrease in the basal rate, and, in some embodiments, also, the bolus, may be instituted to compensate for a predicated additional delivery of fluid. As discussed above, determining the percentage change of insulin delivery may depend on the characterization of the infusion pump.

Following, in some embodiments, where, for example, increasing temperature
25 gradient is the primary concern, the infusion pump processor may be pre-programmed with a "increasing temperature gradient" mode, and the infusion pump may purposefully over deliver, i.e., an automatic percentage increase in the basal rate, and, in some embodiments, also the bolus, may be instituted to compensate for the predicated decrease in delivery of fluid. As discussed above, determining the percentage change may depend on the
30 characterization of the infusion pump.

Closed loop Temperature Compensation

For the purposes of this description, the term "advanced" refers to the movement of a plunger within a syringe or reservoir body. Advancement is not limited to movement in a

particular direction. The syringe has an exit end, which is the end of the syringe in which fluid moves outward from the syringe.

In some embodiments, the system may include one or more devices and / or sensors to determine the effect of the temperature on the syringe/plunger and / or the pumping of
5 fluid, either towards the user / cannula or away from the user / cannula. These devices and / or sensors may include, but are not limited to, one or more flow sensors, one more occlusion devices and / or one or more binary valves, and / or one or more strain beams or sensors and / or one or more optical sensors and / or one or more temperature sensors and / or one or more ultrasonic range sensors and / or one or more potentiometers and / or one or more
10 rotor encoders and / or one or more linear encoders.

With respect to optical sensors, in some embodiments, the infusion pump may include at least one temperature sensor and at least one optical sensor. In some embodiments, the optical sensor may be used to determine that the plunger advanced. In some embodiments, the distance of advancement may also be determined. In some embodiments, a small reflective
15 optical sensor (hereinafter "optical sensor") that fits into the form factor of the infusion pump hardware is used. In various embodiments, the optical sensor has a sensing range that overlaps with the plunger displacements. In various embodiments any optical sensor may be used, including, but not limited to one or more of the following: Sharp GP2S60, Sharp GP2S700 and Sharp GP2A240LC, all of which are manufactured by Sharp Electronics
20 Corporation which is a U.S. subsidiary of Sharp Corporation of Osaka, Japan. This optical sensor contains an infra red emitting diode and infra red sensing detector in a single package. Light from the emitter is unfocused and bounces off the sensing surface, some of which makes it back to the detector resulting in the sensed intensity of light that varies as a function of distance/angle to the reflector. In some embodiments, the sensor is placed such
25 that the reflective surface is the plunger.

In some embodiments, an optical sensor may be used to determine the level of fluid in the syringe / reservoir. This information may be used to determine whether the plunger rod has advanced. Together with the temperature sensor information, this may provide added data / information to determine a temperature dependant change.

30 In some embodiments of the infusion pump system, the infusion pump may include an optical displacement sensor. This sensor may be used to determine whether the plunger rod has advanced, either forward (towards the syringe exit) or backwards (away from the syringe exit), and the distance of the advancement. Using this displacement information, together with the information from the one or more temperature sensors, the effect of the

temperature change on the plunger may be determined. In turn, this determination may increase the accuracy of controls used to compensate for a temperature change. This may include, but is not limited to, decreasing the amount of fluid delivered (i.e., decreasing the volume of fluid that was scheduled to be delivered, i.e., basal rate, or requested to be
5 delivered, i.e., bolus amount) to a sensed forward movement and / or increasing the amount of fluid delivered due to a sensed backwards movement.

In some embodiments, the infusion pump may include an exit valve and /or an occluder. Thus, in these embodiments, the infusion pump includes at least one device to prevent the delivery of fluid either from the syringe to the cannula and / or from the cannula
10 to the user. In some embodiments, the device is activated when the at least one temperature sensor sends a signal to the processor and the processor determines that the temperature change meets a threshold, i.e., that the temperature change is large enough to effect a change in delivery due to temperature. In some embodiments, this may activate the occluder and / or exit valve, preventing fluid from flowing into or out of the syringe and / or
15 the cannula. In some embodiments, the occluder and / or exit valve device is deactivated when the at least one temperature sensor sends a signal to the processor and the processor determines that the temperature change no longer meets a threshold, i.e., that the temperature change is no longer large enough to effect a change in delivery due to temperature. In some embodiments, this may deactivate the occluder and / or exit valve,
20 allowing fluid to flow out of the syringe and / or to the cannula and /or to the user. Again, as discussed above, in some embodiments, the plunger target may be adjusted in response to the information from one or more temperature sensors.

In some embodiments, the occluder / exit valve may be closed during the interval when the infusion pump is not actively delivering fluid so as to prevent inadvertent fluid
25 flow in or out of the syringe / reservoir due to a change in temperature. During the time when the infusion pump is not actively delivering fluid, the at least one temperature sensor may continue to send signals to the processor indicating temperature. This information may be used by the control system to determine whether and how to modify the "next delivery" of fluid, i.e., the next plunger target. Thus, when the "next delivery" is made, the occluder /
30 exit valve may open and the fluid is delivered.

Thus, in these embodiments, the occluder / exit valve may act primarily to prevent spontaneous unintended fluid flow that may be caused by temperature change. The control system may adjust the volume delivery, i.e., plunger target, based on the temperature change such that the volume of delivered fluid compensates for the temperature change.

In some embodiments, the infusion pump may include a compliant component. In some embodiments, the compliant component may allow the difference in volume change in the syringe / reservoir while maintaining a pressure constant. Thus, in these embodiments, controller compensation may not be necessary to compensate for temperature change when
5 the occluder / exit valve is open as there would not be a pressure build up from a change in temperature.

In some embodiments, once a threshold temperature change has been determined, the occluder / exit valve may be closed and the plunger rod may be allowed to float, i.e., the plunger rod may become disengaged with the drive train. A change in pressure would thus
10 allow the plunger to float and find equilibrium, thus adjusting without the need for controller compensation in response to a temperature change.

In some embodiments, the infusion pump may include at least one flow sensor, including, but not limited to, a flow sensor positioned in the exit fluid path. The flow sensor may detect the flow of fluid. This information may be correlated with delivery instructions
15 and a determination may be made whether the fluid delivered was requested and / or a proper delivery. In some embodiments, where flow is detected and it is determined that the fluid delivered was not requested and / or not a proper delivery, the occluder and / or exit valve may be closed. Thus, in some embodiments, a flow sensor may determine fluid flow, either inward or outward, and where this is not an expect event, the infusion pump may
20 activate at least one mechanism, including, but not limited to, an occluder and / or a valve to prevent the continued flow of fluid. Additionally, the flow information may be used to determine the amount or volume of fluid that has been delivered or has flowed inward and this information may be used to alter the plunger target during the next scheduled or requested delivery (e.g., basal or bolus), or, in some embodiments, may be used to alter the
25 delivery schedule. In some embodiments, this may be completed without user interaction. In some embodiments, an alert may be sent to the user and the user must accept the proposed course or action to alleviate the under or over delivery of fluid.

In some embodiments, the infusion pump may include one or more optical sensors. These sensors may be placed in the infusion pump to determine the level of fluid in the
30 syringe / reservoir. The one or more optical sensors may determine the level of fluid before the processor signals the drive train to advance the plunger and after. Thus, the volume difference may be determined before and after the plunger is advanced. However, the at least one optical sensor may, in some embodiments, collect data a preset intervals, regardless or whether the drive train has been activated. Thus, the at least one optical

sensor may collect information to determine when and whether the plunger has advanced and / or when and whether fluid has been delivered or pulled in. Thus, the at least one optical sensor may collect data for the processor to determine when a non-requested delivery event may have occurred. The processor may correlate this information with the at least one temperature sensor and thereby determine whether the infusion pump is experiencing a temperature related effect. In some embodiments, the processor may alert the user. In some embodiments, the information may be used to instigate a control algorithm to compensate for the temperature change effect using, for example, but not limited to, the various embodiments discussed herein.

In some embodiments, a strain beam may be used to identify a plunger moving away from the exit of the syringe. In these embodiments, the strain beam may be positioned relative to the plunger rod such that where the plunger rod begins to move away from the syringe exit, the strain beam will sense the strain. In some embodiments of the infusion pump system, the infusion pump includes a strain beam that may be used to detect and / or identify occlusions. The strain beam and methods may be, in some embodiments, similar to those described in U.S. Patent Application Serial No.12/249,882, filed October 10, 2008 and entitled Infusion Pump Assembly, now U.S. Publication No. US-2010-0094222, published April 15, 2010 (Attorney Docket No. F51); and PCT Application Serial No. PCT/US2009/060158, filed October 9, 2009 and entitled Infusion Pump Assembly, now Publication No. WO 2010/042814, published April 15, 2010 (Attorney Docket No. F51WO), which are hereby incorporated herein by reference in their entireties. However, together with the at least one temperature sensor, a strain beam may determine whether a particular temperature change has resulted in plunger movement. Where plunger movement is detected due to a temperature change, the infusion pump may alert the user. In some embodiments, the system may correlate a change in strain with a change in temperature.

Temperature Maintenance

As discussed above, there may be a desire to maintain the temperature of an infusion pump to avoid any consequences from a temperature change. In some embodiments, to minimize or prevent the above-described effects of temperature changes on the infusion pump and delivery of fluid, one or more various apparatus and/or systems may be employed to maintain the temperature of the infusion pump.

In some embodiments, the infusion pump includes a heater device. The heater device may receive instructions from the processor. The heater device may be located anywhere in or on the infusion pump, however, in some embodiments, the heater device is

located within the infusion pump housing. In some embodiments, the heater device is powered by a power source or battery inside the infusion pump. However, in some embodiments, the power source may be outside the infusion pump.

The heater source may be any heating source desired, however, in the exemplary embodiment, the heating source may be a KAPTON® (Polyimide Film) Heater kit, part number KH-KIT-EFH-15001 and available from omega.com®. In some embodiments, at least one temperature sensor is located in or on the infusion pump. The at least one temperature sensor communicates information to the processor. Based on the temperature sensor data, the processor may act as a thermostat and power the heater source to maintain the temperature in the infusion pump at a desired temperature. In some embodiments, the desired temperature may be between 15 and 30 degrees Celsius, but in other embodiments, the maintenance temperature may be different. In some embodiments, it may be desirable to maintain the temperature at the higher end.

In some embodiments the syringe / reservoir may be contained in a metal case in the infusion pump. The metal case may increase the conduction of heat between the heater element and the syringe / reservoir.

In some embodiments, the at least one heater element may be located in one or more locations inside the infusion pump and one or more of these locations may be selected to maintain the temperature of one or more components of the infusion pump, including, but not limited to, the syringe, fluid, plunger, housing, plunger rod and / or the drive train.

In some embodiments, the at least one heater elements may additionally increase the power source and / or battery life in the infusion pump. Maintaining the temperature at or about 35 degrees Celsius may be beneficial to battery life and / or performance.

In some embodiments, it may be desirable to utilize the user's body as a heat sink, wearing the infusion pump close to the user's skin. This may be accomplished using various devices and apparatus, including but not limited to one or more of the following.

A hook and loop system fastener system, for example, but not limited to one offered by VELCRO® USA Inc. of Manchester, NH, may be utilized to allow for easy attachment / removal of an infusion pump from the user. Accordingly, an adhesive patch may be attached to the skin of the user and may include an outward facing hook or loop surface. Additionally, a surface of infusion pump 114 may include a complementary hook or loop surface. Depending upon the separation resistance of the particular type of hook and loop fastener system employed, it may be possible for the strength of the hook and loop connection to be stronger than the strength of the adhesive to skin connection. Accordingly,

various hook and loop surface patterns may be utilized to regulate the strength of the hook and loop connection.

Referring also to FIGS. 10A-10E, five examples of such hook and loop surface patterns are shown. Assume for illustrative purposes that one surface of infusion pump housing is covered in a "loop" material. Accordingly, the strength of the hook and loop connection may be regulated by varying the pattern (i.e., amount) of the "hook" material present on the surface of adhesive patch. Examples of such patterns may include but are not limited to: a singular outer circle 220 of "hook" material (as shown in FIG. 10A); a plurality of concentric circles 222, 224 of "hook" material (as shown in FIG. 10B); a plurality of radial spokes 226 of "hook" material (as shown in FIG. 10C); a plurality of radial spokes 228 of "hook" material in combination with a single outer circle 230 of "hook" material (as shown in FIG. 10D); and a plurality of radial spokes 232 of "hook" material in combination with a plurality of concentric circles 234, 236 of "hook" material (as shown in FIG. 10E).

In another embodiment, a holder, pouch, sack, container or other type of housing (generally referred to as a "holder") may be sized to accommodate an infusion pump. In some embodiments, the holder may be constructed to include multiple layers including but not limited to, one or more insulating layers. In some embodiments, one or more of the layers may include a fabric that when wetted and refrigerated or frozen, the layer provides a cooling effect. This layer may be desired in warmer climates or in situations where the user's infusion pump may be exposed to the sun or a warm environment. In some embodiments, the one or more layers of material may be highly absorbent material. In some embodiments, the holder may include one or more canisters of isopropyl alcohol which may, when deployed, be absorbed into the highly absorbent material of the holder and provide evaporative cooling to the infusion pump. In various embodiments, the holder may include alternative and/or additional methods, systems and/or devices for cooling the infusion pump.

In some embodiments, the holder may include one or more temperature measurement devices and/or temperature sensors that may transmit information to the infusion pump and/or a controller. The one or more temperature sensors may communicate the temperature of the holder and either deploy the one or more canisters of alcohol and or alert the infusion pump/user/controller and / or turn o the heating source, based on the temperature sensor. In some embodiments, the heating and/or cooling may be triggered by reaching a threshold change in temperature. Thus, in some embodiments, the holder may provide for a closed-loop system for maintaining the temperature for the infusion pump.

Referring now to FIG. 11, some embodiments of the holder 500 include an outside layer 502, an inside layer 504 and an inner pocket 506. The pocket 506 may include additional cushion or insulation to both protect the infusion pump from outside forces and / or temperature change. The holder 500 may include a fastener along the front, top or the side. In some embodiments, the holder 500 may include the holder may include a pull down flap (not shown) on the front to expose the screen and / or input assemblies (e.g., including but not limited to buttons, sliders, and / or jog wheels). In some embodiments, the flap may be secured closed using a hook-and-loop system. In other embodiments, the flap may be secured using any other fastener system including, but not limited to, snaps, buttons, magnetic closures and zippers.

In some embodiments, the holder 500 may be attached to a strap 508 designed to be attached to the user (see FIG. 12 for example). However, in various embodiments, the strap 508 may be elastic and / or adjustable and may include at least one closure device. Although shown in FIG. 12 as being worn about the mid section of a user 510, the holder 500 may be worn anywhere the user desires.

Referring now to FIG. 13, an embodiment of the back of the holder 500 is shown. In some embodiments, the holder may include a clip 512 which may be referred to as a "belt-clip" or another type of clip configured such that it securely and removably fits over a belt, handle, piece of clothing or other. In some embodiments, the holder 500 may additionally include an opening 514 for tubing 516 to fit through. In some embodiments, the infusion pump (not shown) may be contained inside the holder 500 and the holder worn close to the insertion site (not shown) on the user such that minimal tubing 516 is exposed to the outside temperature. Thus, embodiments of the holder 500 including an opening 514 for tubing may be beneficial for maintaining the temperature of the tubing 516 and / or the fluid in the tubing.

In some embodiments, a plastic material for example, a Press n' Seal, or another material of similar behavior, may be used to attach and maintain the infusion pump against the user's body. In other embodiments, a cuff or band fitted against the leg, midsection or arm, for example, of a user may include a pouch for the infusion pump. In other embodiments, the infusion pump may be maintained in position against the skin through inner pockets, bra pockets, etc.

Various embodiments are described herein for both utilizing the user's body heat and / or a heating element to maintain the temperature of the infusion pump. However, additional devices and apparatus are within the scope of the invention. Further, various

methods, systems and apparatus for maintaining the temperature of an infusion pump may include at least one temperature sensor.

INSULIN TEMPERATURE

Described herein are various methods, systems, devices and / or apparatus for
5 maintaining the temperature of an infusion pump. Inherent in at least some of these
embodiments is the maintenance of the infusible fluid / insulin temperature. It is well know
that manufacturers of insulin recommend that the temperature of insulin not exceed a high
and a low temperature. Additionally, it may be beneficial to maintain fast-acting (e.g.,
HUMALOG®, NOVOLOG®) at room/ambient temperature (e.g., between 59 and 86
10 degrees Fahrenheit) once the vial has been used, i.e., the manufacturer recommends storing
insulin in a refrigerated area, e.g., between 36 and 46 degrees Fahrenheit, until the vial is
used. From that point on, it is recommended that the vial be stored at room temperature.

As insulin may be less effective or not effective once it has reached a non-
recommended temperature, it may be beneficial for a user to know whether the insulin has
15 been properly stored, whether while in transit, in the refrigerator or while in use.

Referring to FIG. 14, in one embodiment, a stick-on temperature gauge 520 may be
placed on a vial 522 of fluid, and in some embodiments, on a vial of insulin. The gauge
may tell the user the current temperature of the vial. In some embodiments, the temperature
may be indicated as various shades of red and blue, indicating various temperatures towards
20 the high and low range. In some embodiments, once the temperature has reached either the
maximum or minimum temperature (which is predetermined and may, in some
embodiments, be 35 and 87 Fahrenheit respectively), the gauge becomes non-reversible,
thus indicating instantly to the user that the insulin has reached either a maximum or
minimum temperature.

25 Any stick-on temperature gauge may be used including a non-reversible temperature
label such as a Non-Reversible Temperature Labels, 3 Temperature Ranges, part number
TL-3 available from omega.com®, or another similar temperature label. As discussed
above, in some embodiments, a Reversible Temperature Label may be used or a label with
both reversible and non-reversible components

30 Atmospheric Pressure

A decrease in atmospheric pressure may result in unintentional and / or unscheduled
and/or non-requested delivery of fluid from a reservoir in an infusion pump to a user. A
decrease in pressure effects air that may be in the reservoir and/or may be dissolved in the
fluid in the reservoir. Some embodiments of infusion pumps which may be affected are

syringe infusion pumps and those similar to a syringe infusion pump, which may include, but is not limited to, various embodiments shown and described in U.S. Patent No. 7,498,563 issued March 3, 2009 and entitled Optical Displacement Sensor for Infusion Devices (Attorney Docket No. D78); U.S. Patent No. 7,306,578 issued December 11, 2007 and entitled Loading Mechanism for Infusion Pump (Attorney Docket No. C54); and PCT Application Serial No. PCT/US09/060158 filed October 9, 2009 and entitled Infusion Pump Assembly, now Publication No. WO2010/042814, published April 15, 2010 (Attorney Docket No. F51WO) which are all hereby incorporated herein by reference in their entireties, and shown in FIGS. 1A-4. Thus, in operation, where the syringe infusion pump experiences an atmospheric pressure decrease, an unintended bolus may be delivered to a user. This presents a safety concern as the unintended bolus may also be unknown to the user. Thus, the user may experience an over delivery event which, in the embodiments including an insulin pump, may result in a hypoglycemic event.

An increase in atmospheric pressure may result in an unintentional and / or unscheduled siphoning of fluid from the tubing / cannula towards the reservoir in an infusion pump. Some embodiments of infusion pumps which may be affected are those similar to a syringe infusion pump, which may include, but is not limited to, various embodiments shown and described in U.S. Patent No. 7,498,563 issued March 3, 2009 and entitled Optical Displacement Sensor for Infusion Devices (Attorney Docket No. D78); U.S. Patent No. 7,306,578 issued December 11, 2007 and entitled Loading Mechanism for Infusion Pump (Attorney Docket No. C54); and PCT Application Serial No. PCT/US09/060158 filed October 9, 2009 and entitled Infusion Pump Assembly, now Publication No. WO2010/042814, published April 15, 2010 (Attorney Docket No. F51WO), and FIGS. 1A-4. Thus, in operation, where the syringe infusion pump experiences an atmospheric pressure increase, an unintended siphoning of fluid from the tubing / cannula may occur which may result in a less than intended volume delivered to a user. This presents a safety concern as the siphoning volume may also be unknown to the user. Thus, the user may experience an under delivery event which, in the embodiments including an insulin pump, may result in a hyperglycemic event.

In some embodiments, the syringe infusion pump and / or the remote controller for the syringe infusion pump may include a pressure sensor, which in some embodiments may be an altimeter, similar to those known in the art. The terms "pressure sensor" and altimeter" may be used interchangeably herein. The altimeter may be in communication with the pump processor and therefore, the data from the altimeter may be used by the pump

processor. In some embodiments, the processor may include predetermined rate of change and / or atmospheric pressure thresholds (either increases or decreases) that trigger at least one response from the infusion pump.

In some embodiments, the response may include notification to the user. Thus, the
5 infusion pump and / or a remote controller may notify and / or alarm and / or alert the user where the altimeter sends data indicating an increase and / or a decrease in atmospheric pressure which has triggered a threshold. In some embodiments, the processor may recognize, from the altimeter data, potential events, e.g., airplane take-off, airplane decent, traveling to / from high altitudes to low altitudes. These recognized events may, in some
10 embodiments, trigger at least one comment to the user, for example, the pump and / or controller may alert and / or alarm the user with a question, which may include, for example, but is not limited to, "airplane take-off?" and / or "airplane decent?". Upon confirmation by the user, the pump may suggest, e.g., by an alert and / or an alarm e.g., either by an audio and / or visual signal to the user, that the user disconnect from the
15 cannula. Following, when altimeter data indicates that a threshold "safe" altitude has been reached and / or the user is at an appropriate altitude for a predetermined period of time, the pump / controller may alert and or alarm the user to reconnect to the cannula. Thus, in some embodiments, any potential adverse effects caused by atmospheric pressure changes may be minimized and / or mitigated and /or avoided by notification to the user followed by
20 user disconnect and / or reconnect as appropriate.

Referring now also to FIG. 15, a method for atmospheric pressure mitigation 600 is shown. In some embodiments, the pressure sensor/altimeter sends data to a processor at predetermined intervals 602. If the altimeter data indicates a predetermined alert and / or
25 alarm threshold 604, the processor may alert and / or alarm the user to disconnect from the cannula 606. When the altimeter indicates a predetermined appropriate/safe threshold has been met 608, the processor may alert and / or alarm the user to re-connect to the cannula 610. However, until the predetermined appropriate threshold has been met 608, the altimeter continues to send data to the processor at predetermined intervals 612.

In some embodiments, the altimeter may send data to the processor at predetermined
30 intervals which may be, but is not limited to, every minute. In some embodiments, the frequency may increase or decreased based on altimeter data. For example, in some embodiments, where airplane take-off is confirmed by the user, the altimeter may send data to the processor more frequently. In some embodiments, once the user has reconnected, the altimeter may send data to the processor based on entered events by the user. For example,

in some embodiments, where the user foresees airplane travel, (airplane travel is used merely as an example, in other embodiments, the event may be any event which may result in a change in atmospheric pressure) the user may select either on the pump and / or the controller, a menu option in the user interface to indicate to the pump to be placed in

5 "airplane mode". This mode may also request the user to enter additional information, for example, scheduled take-off time, and / or scheduled landing time. Thus, the pump and / or controller may modify the frequency of the altimeter data communication based on user input information. The user input information may additionally be used by the pump and / or controller to recognize changes in the events through readings from the altimeter. For

10 example, the processor may recognize that where a decrease in atmospheric pressure may be anticipated based on a user entered take-off time is not realized, the pump / controller may request further information from the user regarding changed take-off time. The user entered event information may additionally be used by the processor to confirm and altimeter function and / or accuracy. For example, where a reading during take-off is not as

15 expected, even within a preprogrammed margin of error, the pump / controller may alarm / alert as this may indicate a malfunction of the altimeter. In some embodiments, the pump / controller may then alert the user to disconnect during take-off and decent.

In some embodiments, the data from the altimeter and / or data from a pressure sensor may be used to modify the scheduled delivery of fluid. Thus, the altimeter and / or

20 pressure sensor may be in communication with the infusion pump processor. A sensed changed in pressure, either in a positive or negative direction, may be communicated to the processor. In response, the processor may communicate to the controller to either decrease or increase the rate of delivery of the infusible fluid. For example, the controller may increase or decrease any scheduled delivery for a predetermined period of time by a

25 predetermined percentage. In some embodiments, the infusion pump may include a mode or other preprogrammed delivery schedule modifier to address situations where the infusion pump may experience an increase or decrease in pressure which may effect the delivery of fluid. The mode may be selected by a user when the user is experiencing or plans to experience a change in pressure event, for example, but not limited to, flying in an airplane.

30 The user may select the mode which may be termed an "airplane mode" in some embodiments (however, this is merely an example of a name and also, the term may be used to identify any change in pressure event in various embodiments and in various embodiments is not limited to airplane events), and may additionally specify whether taking

off or landing, for example. In response, the infusion pump may increase or decrease the rate of delivery.

In some embodiments, where the altimeter data indicates a change in pressure event which may result in an unintentional / unintended increase or decrease in fluid delivery, and / or where the user has indicated same to the pump and / or controller, for example, but not limited to, one or more of the following, through menu selection and / or manual entry and / voice recognized command, the pump may enter an "airplane mode" which may, in some embodiments, include a modification of the frequency of determination of the location of the plunger. In some embodiments, for example, as described above and / or in U.S. Patent No. 7,498,563 issued March 3, 2009 and entitled Optical Displacement Sensor for Infusion Devices (Attorney Docket No. D78), the infusion pump may include at least one sensor for determining the location of the plunger. Although, in some embodiments, this may be accomplished by using the methods, apparatus and systems described above, and / or in U.S. Patent No. 7,498,563 issued March 3, 2009 and entitled Optical Displacement Sensor for Infusion Devices (Attorney Docket No. D78), in other embodiments, other sensors for determining plunger movement or plunger location may be used. However, in the various embodiments, the frequency at which the sensor determines the position of the plunger may vary in "airplane mode". For example, in some embodiments, during normal operation, the infusion pump may determine the position of the plunger before and after a scheduled and / or requested delivery. However, in some embodiments, in airplane mode, to determine a movement of the plunger which may not be due to a scheduled and / or requested delivery, the infusion pump may modify the frequency of the sensor readings to determine the volume of fluid either siphoned or delivered due to a change in pressure event. Thus, upon entering airplane mode and / or upon the altimeter data triggering the mode, the sensor may take readings at predetermined intervals, e.g., every 1 minute. In some embodiments, where the sensor readings indicate a movement either towards delivery or siphoning, an estimated volume of fluid either delivered or siphoned may be presented to the user. Thus, the user may make appropriate changes in therapy based on this information. In some embodiments, however, the sensed volume of fluid either delivered and / or siphoned may be used by the processor to modify the scheduled deliveries for a predetermined period of time. In some embodiments, the predetermined period of time may be dependant on many factors, including, but not limited to, the volume of fluid for which the infusion pump is correcting.

Referring to the description above with respect to temperature changes and mitigation, in some embodiments, a similar mode regarding sensing the position of the

plunger may be entered into automatically and / or manually upon a change of pressure threshold being met. Thus, the various methods described regarding the various embodiments pertaining to sensor frequency modification and downstream modification of delivery may be used for pressure mitigation.

5 In some embodiments, the infusion pump may include at least one valve located downstream from the reservoir. In various embodiments, the valve may be located anywhere between the distal side of the reservoir to the cannula site, including, but not limited to, built into the infusion set itself, including but not limited to one or more of the following: in the tubing, in the cannula, and/ or on the distal end of the reservoir. In some
10 embodiments, the at least one valve may be a pressure / atmospheric compensation valve. In some embodiments, the valve may be a micro check valve similar to the one shown in Appendix A (Lee 250 Zero Leak Chek® available from The Lee Company, Westbrook, Connecticut, USA), configured such that the valve remains fully closed with any pressure differential that is higher on the cannula side of the valve compared with the reservoir side
15 of the valve (which may also be referred to as “downstream from the valve” and “upstream of the valve” respectively), i.e., when the valve is closed, no fluid may flow back to the reservoir. In some embodiments, the outflow cracking pressure may be selected such that a differential pressure related to the change in altitude would not cause the valve to open. For example, in some embodiments, the cracking pressure may be set to 5 PSI. Thus, in this
20 embodiment, at sea level, the infusion pump may be required to generate 5 PSI to induce flow. During, for example, pressure decreases, such as those experienced during airplane flight, the infusion pump may be required to induce 1 PSI, for example, to induce flow due to the negative pressure bias of the altitude change. In some embodiments, fluid flow based on altitude changes alone may be eliminated and / or decreased and / or mitigated. Thus, in
25 embodiments such as these, the effect of pressure changes may be mitigated while the user receives the intended and / or scheduled and / or requested therapy deliveries.

Air Bubble Management

Air bubbles and / or air dissolved in the fluid in a syringe reservoir similar to the ones shown and described in U.S. Patent No. 7,498,563, issued March 3, 2009 and entitled
30 Optical Displacement Sensor for Infusion Devices (Attorney Docket No. D78); U.S. Patent No. 7,306,578, issued December 11, 2007 and entitled Loading Mechanism for Infusion Pump (Attorney Docket No. C54); and PCT Application Serial No. PCT/US2009/060158, filed October 9, 2009 and entitled Infusion Pump Assembly, now Publication No. WO 2010/042814, published April 15, 2010 (Attorney Docket No. F51WO), may affect fluid

delivery. Air bubbles and/or dissolved air in the fluid de-gassing, displaces fluid, and may expand and / or be compressed, which may effect delivery. Additionally, air bubbles may affect occlusion detection in some embodiments of infusion pumps. For example, with many infusion pump systems, occlusion detection is performed using a strain beam / strain gauge to detect the upstream pressure exerted from the plunger towards the strain beam. When the pressure reaches a threshold, an occlusion is determined and / or assumed by the system and generally, an occlusion alarm and / or alert is given to the user. However, this occlusion detection system relies on the fluid in the reservoir being non-compressible.

When the fluid in the reservoir includes at least one air bubble, as air is compressible, additional force within the reservoir, due to an occlusion, must first compress the air bubbles prior to the force being exerted onto the strain gauge. This may ultimately require more force be present to detect an occlusion. Thus, air bubbles in the reservoir may contribute to a delay in occlusion detection. Therefore, for many reasons, including occlusion detection, it may be desirable to minimize, mitigate and / or eliminate air bubbles and/or dissolved air in the fluid in the reservoir.

Additionally, as air bubbles increase in size, they may increase the fluid pressure within the reservoir. Increased fluid pressure within the reservoir may cause unintentional and / or unscheduled delivery of a volume of fluid (which, in some embodiments, is insulin).

20 Mitigation of Over-delivery Caused By Air

With respect to mitigation of air bubbles to minimize and /or eliminate unintentional and / or unscheduled fluid delivery, in some embodiments, a three-way valve may be located downstream from the reservoir. Referring now to FIG. 16, in some embodiments, both an active check valve 650 and a passive check valve 652 may be located downstream from the reservoir 654. In some embodiments, the active check valve 650 may be opened for intended and / or scheduled and / or requested therapy deliveries but otherwise, remain closed. The passive check valve 652 may be cracked only when sufficient pressure is exerted on the valve to overcome the valve. Thus, in some embodiments, when there are no intended and / or scheduled and / or requested therapy deliveries, the active valve 650 remains closed. This continues unless and until the fluid pressure is sufficient to overcome the passive check valve 652, thus, no fluid will pass through either valve. However, in some cases, increased fluid pressure, e.g., from an air bubble, may overcome the passive check valve 652 (i.e., may overcome the cracking pressure of the passive check valve 652) and flow outside of the pump (and in various embodiments, the fluid flowing through the

passive check valve 652 may flow anywhere desired except to the user). Thus, in this embodiment, only intended and / or scheduled and / or requested therapy deliveries will be made, otherwise, increased fluid pressure may be mitigated (and unintended and /or unscheduled fluid deliveries avoided and / or mitigated and /or decreased) through use of a
5 passive check valve 652.

Air Bubble Minimization

Air bubbles may be introduced into the reservoir by various methods and due to various circumstances, including, but not limited to, fluid out-gassing. In some cases, the fluid may out-gas after being introduced into the reservoir. This may occur as a result of
10 temperature. In some cases, for example, where insulin is used as the fluid, insulin that is below room temperature may experience a certain amount of out-gassing while coming to room temperature. Comparatively, insulin that is and has been at room temperature for a period of time may not experience as much out-gassing, thus, insulin in this state may undergo minimal or less out-gassing in the reservoir as compared with insulin that was
15 below room temperature when loaded into the reservoir.

Therefore, a method, system and apparatus for increasing the out-gassing of insulin and / or a fluid prior to loading into the reservoir may be desired. This may minimize the effects of out-gassing, that is, minimize the effects of air bubbles in the reservoir.

Referring now to FIG. 17, in some embodiments, a fill adapter device 700 may be
20 used to minimize the effects of out-gassing. In some embodiments, the fill adapter 700 may be a reusable fill adapter, however, in other embodiments; the fill adapter 700 may be disposable. In some embodiments, the fill adapter 700 device may be connected to the vial 702 (i.e., configured to be connected and/or removably attached to a vial) of infusible fluid to be used while filling and / or partially filling a reservoir / syringe 704 with infusible fluid
25 which in some embodiments is insulin. In some embodiments, the fill adapter 700 may be attached and/or removably attached to the vial 702 at manufacture and in some embodiments; a user may attach the fill adapter 700 at the time of use (and in some of these embodiments, the fill adapter 700 may be removably attached). In some embodiments, therefore, a vial 702 may be provided together with the fill adapter 700 and in some
30 embodiments, the reservoir 704 may be provided to a user together with the fill adapter 700. In other embodiments, the fill adapter 700 may be a separate device from the vial 702 and / or reservoir 704. In some embodiments, the fill adapter 700 may additionally include a needle (not shown) connecting the fluid from the vial to the fluid pathway 712. In some embodiments, as the fill adapter 700 is being attached to the vial 702, the needle

The device may include a heat exchanger which may include a heating element 706 and a fluid pathway 712, for example, but not limited to, a length of tubing / fluid pathway (which may be made from glass and / or plastic or any fluid compatible material). The fluid pathway 712 may be fluidly connected to a septum and/or a filling needle input 714. In
5 some embodiments the length of tubing may be any length and / or diameter to most efficiently and effectively induce out-gassing. While filling the reservoir / syringe 704 (which may, in some embodiments, include at least one plunger 708), the fluid enters and passes through the heat exchanger including the fluid pathway 712 which is heated by the heating element 706 where it may be heated to a predetermined temperature. While being
10 heated to the predetermined temperature, out-gassing may occur.

Some embodiments of the fill adapter 700 include a heat source and / or heating element 706. In various embodiments, the heating element 706 may be any heating element known in the art which may include, but is not limited to the following, inductive, optical, RF, microwave, electrical or other.

15 In some embodiments, the fluid path 712 and / or the fill adapter 700 may be designed to heat the fluid at a desired and/or predetermined rate. Thus, in some embodiments, there may be additional features on the fill adapter 700 to control the rate of heating of the fluid and or the flow rate of the fluid through the heating element 706. These may include, but are not limited to, a pump and/or an active valve.

20 In some embodiments, the fluid may be heated to room temperature. In other embodiments, the fluid may be heated to less than room temperature and in still other embodiments; the fluid may be heated to above room temperature. In some embodiments, the fill adapter 700 may include a processor (not shown) which may control the heating of the fluid according to one or more preprogrammed profiles. The one or more profiles may
25 be designed for various situations and / or various types of fluids. Depending on the desired temperature, the heat exchanger and / or the fill adapter 700 may be designed accordingly.

Thus, in various embodiments, use of an embodiment of the fill adapter 700 may act to accomplish at least, but not limited to, one or more of the following: minimize, decrease and/ or eliminate downstream effects of out-gassing; minimize, decrease and/or eliminate
30 the subjective amount of out-gassing such that the amount of out-gassing is controlled and / or predictable and therefore may be mitigated through other means; decrease, minimize, eliminate and/ or lessen the occurrence of out-gassing; stabilize the temperature of the fluid to minimize potential effects of the temperature increase between, for example, refrigerated temperature and room temperature; decrease, eliminate, and/ or minimize and /or lessen the

effects of out-gassing in the reservoir 704, including but not limited to, volume changes in the reservoir 704.

In some embodiments, there may be an air trap and / or a hydrophobic filter (not shown) or other to allow the escape of the air from the heat exchanger. Thus, while the fluid is heated to the predetermined temperature out-gassing occurs and therefore may minimize out-gassing which may otherwise have occurred after filling a reservoir and / or syringe 704.

In some embodiments, a heating apparatus (not shown) may be used to heat the reservoir 704 following fill and / or partial fill (the term "fill" may be used to refer to the transfer of any volume of fluid into the syringe / reservoir, regardless or whether the volume of fluid reaches maximum capacity or partial capacity) of the reservoir 704. The heating apparatus may be a nondisposable / reusable type apparatus which may include a heating element, e.g., inductive, optical, RF, microwave, electrical or other. The heating apparatus may be configured such that the filled reservoir is accommodated in heating communication with the heating element. The heating element may be located such that heat may be communicated to the reservoir and the heat may heat the fluid within the reservoir to a desired temperature. In some embodiments, the heating apparatus may be designed to heat the fluid at a desired rate. Thus, in some embodiments, there may be additional features on the heating apparatus to control the rate of heating of the fluid.

In some embodiments, the fluid may be heated to room temperature. In other embodiments, the fluid may be heated to less than room temperature and in still other embodiments; the fluid may be heated to above room temperature. In some embodiments, the heating apparatus may heat the fluid according to one or more preprogrammed profiles. The one or more profiles may be designed for various situations and / or various types of fluids. Depending on the desired temperature, the heating apparatus may be designed accordingly.

Thus, in various embodiments, use of an embodiment of the heating apparatus may act to accomplish at least, but not limited to, one or more of the following: decrease, minimize and/or eliminate downstream effects of out-gassing; decrease, minimize and/or eliminate the subjective amount of out-gassing such that the amount of out-gassing is controlled and / or predictable and therefore may be mitigated through other means; decrease, minimize and/or eliminate and/ or lessen the occurrence of out-gassing; stabilize the temperature of the fluid to minimize potential effects of the temperature increase between, for example, refrigerated temperature and room temperature; decrease, minimize

and/or eliminate and /or lessen the effects of out-gassing in the reservoir, including but not limited to, volume changes in the reservoir.

During the heating, the fluid may out-gas. Thus, following heating, the reservoir may be removed from the heating apparatus and air may be pushed out of the syringe /
5 reservoir through, for example, but not limited to, a filling needle 710, prior to loading the reservoir 704 into the infusion pump. Thus, the heating apparatus may minimize and / or eliminate thermally produced fluid delivery errors.

In some embodiments, degassing of the fluid may be accomplished prior to loading fluid into a reservoir or prior to loading a filled reservoir into an infusion pump by
10 subjecting the fluid to a partial vacuum. This may be accomplished through a number of embodiments, including, but not limited to, the following.

In some embodiments, once fluid is filled into the reservoir, the filling needle may then be removed from the reservoir and the reservoir may be capped with a cap that does not allow the movement of fluid in or out of the reservoir. The plunger may be pulled back
15 to apply a vacuum to the fluid within the reservoir. Out-gassing may occur. Released air may then be pushed out of the reservoir prior to loading into an infusion pump.

In some embodiments, following filling of the reservoir, the reservoir may be placed into a device or other where the reservoir is put under a partial vacuum. The fluid may out-gas. Next, the reservoir may be loaded into the infusion pump.

In some embodiments, in addition to heating to out-gas, a system may also combine a vacuum with an elevated temperature /heating element, which may result in heating the fluid to a higher temperature. In some embodiments, the temperature increase may be minimized when applied together with a vacuum. Additionally, the vacuum applied may be minimized when applied together with a temperature increase. Thus, in some embodiments,
20 where the fluid is heated and a vacuum is applied to the fluid, the temperature increase and/or the level of vacuum applied may be minimized. Thus, in some embodiments, it may be desirable to apply as low a vacuum as possible, thereby decreasing the amount of turbulence and/or rate of flow through a heat exchanger and /or minimizing the contact area over a heat exchange surface, and therefore minimize and or prevent extreme temperature
25 and / or extreme pressure change. This may be desirable for many reasons, including, but not limited to, maintaining the viability of the fluid.

In some embodiments, while under pressure, the fluid may be removed from a vial into a reservoir and/or syringe or other, and once the desired volume of fluid has been loaded into the reservoir/syringe or other, the fluid path between the reservoir/syringe and

the vial may be closed and the syringe plunger may continue to be pulled back, i.e., applying a vacuum onto the fluid. Following, the syringe or other may be vibrated and/or shocked and / or a force may be provided at a predetermined point for a predetermined time, i.e., a force pulse. This may enhance / amplify air bubble formation i.e., fluid de-gas, and thus, in some embodiments, following vibration/force application, the air / gas may be pressed out of the reservoir/ syringe.

In some embodiments, an automated filling device may be used which may connect a reservoir/syringe to a vial of fluid by a fluid line, which, in some embodiments, may be a filling needle. In some embodiments, the device may automate the filling of the reservoir/syringe. Following, in some embodiments, the device may close/occlude the fluid line and provide the vibration and/or force to the reservoir/syringe (i.e., pulling a vacuum into the reservoir/syringe). In some embodiments, this method may be completed more than once, e.g., 2 or more times and/or until, in some embodiments, based on the volume of fluid in the reservoir/syringe and the amount of air extracted on any given attempt, the device may determine whether a threshold volume of air has been removed from the fluid, i.e., there may be a predetermined threshold goal amount of air to be extracted. In some embodiments a syringe having a volume, for example, of 1.5-5 cc, may be used and filled to half or a portion of the volume, followed by a vacuum being applied. In some embodiments, the device may include a camera and/or other sensor to determine the volume of fluid before and after air extraction/de-gas to determine if the threshold goal has been met. In some embodiments, the device may communicate with the controller for the infusion pump and / or the pump to input the amount of fluid in the reservoir prior to the reservoir being loaded into the infusion pump. In some embodiments, this system may be beneficial for many reasons, including but not limited to, improving air mitigation and increasing the accuracy of the volume of fluid filled into a syringe/reservoir. In some embodiments, the above-described system and method may include an optical sensor or other sensor to determine the plunger's displacement.

In some embodiments, the automated filling device may measure the temperature of the fluid and this may be input into a control system 728 that determines the amount of effort that is exerted onto the filled reservoir/syringe, i.e., how much force is applied onto the syringe to extract the air. For example, in colder temperatures it may be more difficult to remove the air and therefore, may require more or longer application of vacuum and/or more or longer application of vibration and/ or force or both. In some embodiments, the temperature of the fluid may be input into a control system 728 and the amount of heating

of the fluid may be determined using the temperature readings. In some embodiments, the temperature readings may be used to determine both the amount of force applied to the syringe and the amount of heating applied to the fluid.

In some embodiments, to minimize the vacuum applied to the reservoir/syringe, for example, where it may be desirable to protect the fluid, the device, in some embodiments, may measure the force (e.g., may include a pressure sensor) being pulled on the syringe to correlate the force with the pressure being exerted onto the fluid and therefore, it may be determined when the vacuum has been depleted such that the vacuum no longer is working. Thus, the force or pull on the reservoir/syringe may be an output to determine when to stop/cease the force or pull and also, to determine when a sufficient amount of air has likely been pulled from the fluid, based on the force.

In some embodiments, using an optical sensor, for example, an optical displacement sensor, to determine the displacement of the plunger, together with the pressure sensor to determine the pressure being exerted onto the fluid, the control system 728 may calculate the volume of air removed as well as correlate pressure with displacement.

Referring now to FIG. 18 one embodiment of a system for maintaining a lower positive pressure within a fluid vial 702 is shown. It may be desirable to maintain the fluid which will eventually be used in a reservoir at or near atmospheric pressure rather than at a pressure which may result in a greater volume of dissolved gas in the fluid. Thus, in some embodiments, maintaining the fluid at or near atmospheric pressure may minimize post reservoir fill fluid out-gassing as the amount/volume of dissolved gas in the fluid is limited compared to embodiments where the pressure inside the vial is higher or increases. As shown in the FIG. 18, in some embodiments, a needle 716 is inserted through the septum 718 of the vial 702. The needle 716 may include two ends which are each open to the atmosphere. However, in some embodiments, the end exposed to the outside of the vial 702 may include a filter, which, in some embodiments, may be a hydrophobic filter (not shown), to maintain sterility and/or to maintain the needle as dry.

In some embodiments, the needle 716 may include a one-way check valve 720 on one end of the needle 716. In some embodiments, the one-way check valve 720 may have a 1 or 2, for example, PSI cracking pressure. When the pressure within the vial 702 is high enough, the vial 702 will vent. This may lower the positive pressure in the vial. In some embodiments, the check valve 720 may limit the internal vial 702 pressure so that it is no greater than atmospheric pressure plus 1 or 2, for example, additional PSI. Thus, in these

embodiments, the apparatus/system shown in FIG. 18 may be beneficial for many reasons, including, but not limited to, limiting the pressure due to atmospheric pressure change.

Referring now also to FIG. 19, in some embodiments, the device/system shown in FIG. 18 may additionally include a vial manager apparatus 722 that may be sized and
5 shaped to accommodate the vial 702 such that the vial manager apparatus 722 may be removably attached to the vial 702. In some embodiments, the vial manager apparatus 722 may include a pump 724, which may also be termed an air pump, in fluid connection with the inside of the vial 702 through a needle 716. The pump may be used for pumping air out
10 of the vial 702, which may be, in some embodiments, an electromechanical pump and / or a pump that may be manually operated. The pump 724 may be used to apply a low vacuum on the inside of the vial 702. In some embodiments, the pump 724 may be a diaphragm pump that may be battery operated and works to pull, e.g., a PSI less than atmospheric pressure, which, in various embodiments, may include pulling at PSI from less than 1 to 12,
15 for example, vacuum on the inside of the vial 702. In some embodiments, the vial manager apparatus 722 may include a power source, i.e., a battery 726, to provide power to at least the pump and/or the processor. In some embodiments, the vial manager apparatus 722 may additionally include a processor 726 and/or a timer that may be preprogrammed to turn the pump 724 on and off to limit the vacuum, e.g., the pump 724 may pump for 30 seconds every 5 minutes. However, in some embodiments, the duration that the pump is on and / or
20 the frequency of the durations may depend on the leak rate of the vial 702. In some embodiments, the pump 724 may run constantly.

In some embodiments, the vial manager apparatus 722 may additionally include a pressure sensor (not shown) located within the path of the needle 716. In various
25 embodiments, the pressure sensor may communicate with the processor/control system 728 and the pump 724 may be activated based on the pressure data from the pressure sensor. In some embodiments, where a pressure sensor is included in the needle 716, the device may determine if the vial 702 has tipped using the pressure sensor reading. In some
30 embodiments, where a tip is determined, the vial manager apparatus 722 may alarm using any type of alarm including but not limited to, blinking or one or more lights, audio alarm and/or vibratory alarm. Determining when the vial 702 has tipped may be beneficial for many reasons, including but not limited to, once the vial 702 has tipped, the air pump 724 may not be able to pump air since fluid may be in contact with the needle 716. Thus, the vial manager apparatus 722 may not be able to pull a vacuum on the vial 702. Thus, it may

be desirable to alarm/alert once the vial 702 has tipped. This alarm/alert may, in some embodiments, be triggered by the pressure sensor.

In some embodiments, the vial manager apparatus 722 may include one or more lights to indicate conditions, for example, one or more green lights and one or more red
5 lights, indicating the status of the vial manager apparatus 722 and/or the vial 702. In some embodiments, the vial manager apparatus 722 may include one light which may, by, e.g., blinking, indicate various status conditions.

In some embodiments, the vial manager apparatus 722 may include at least one
10 accelerometer that may be connected to a processor 728. This may be used to determine when /if the vial has tipped while in storage. In some embodiments, the vial manager apparatus 722 may additionally include at least one alarm (for example, vibratory and/or audio and /or visual) to alert the user/care giver that the device has tipped. In some
15 embodiments, the needle 716 may include a filter, which, in some embodiments, may be a hydrophobic filter (not shown). The hydrophobic filter may be beneficial for many reasons, including, but not limited to, protecting the air pump 724 from pumping fluid

In some embodiments, the vial manager apparatus 722 processor 728 may include a vial manager control system. The system may include at least one temperature sensor which may be located inside the vial manager apparatus 722 and may be in communication
20 with the processor 728. The at least one temperature sensor may provide temperature data on a predetermined frequency, e.g., every 5 minutes, and at a threshold high or low temperature reading, the apparatus 702 may alarm/alert. In some embodiments, the vial manager apparatus 722 may include a time keeper which, when, for example, the vial manager apparatus 722 is connected to a vial 702, the timer may be initiated, and at a
25 predetermined time, e.g., 28 days, the vial manager apparatus 722 may alarm/alert the user that the vial should be replaced and/or has been in use for the predetermined amount of time. This may be beneficial for many reasons, including, but not limited to, alerting the user when the fluid inside the vial 702 may be passed the expiration date thereby ensuring the user does not use expired fluid and/or medication for therapy.

The vial manager apparatus 722, in some embodiments, may be made from any
30 material, including, but not limited to, any type of plastic and/or metal. In some embodiments, the vial manager apparatus 722 is placed over the top of the vial 702 and once the needle 716 pierces the septum 718, the timer may initiate a countdown. Thus, the vial manager apparatus 722 provides a system for maintaining the pressure in a vial 702 and also, for ensuring providing a method for determining when the vial 702 was first used, i.e.,

when the needle 716 is first inserted into the vial 702. In some embodiments, the vial manager apparatus 722 may be used while a vial 702 is "in use", e.g., while a user is using the vial 702 for therapy.

In some embodiments, the vial manager apparatus 722 may include a disposable portion and a reusable portion. For example, in some embodiments, the portion of the vial manager apparatus 722 that connects with the vial 702, including the needle 716, may be contained in the disposable portion. Thus, the reusable portion may include, but is not limited to, the processor, power source, and pump, etc. This may be beneficial for many reasons, including, but not limited to, reusability of many elements of the vial manager apparatus 722.

In some embodiments, a stick-on pressure and/or force gauge may be placed on a vial of fluid, and in some embodiments, on a vial of insulin. The gauge may tell the user the current pressure of the vial. In some embodiments, the pressure may be indicated as various color shades. Any stick-on pressure gauge may be used including a non-reversible pressure label. In some embodiments, a Reversible Pressure Label may be used or a label with both reversible and non-reversible components may be used.

In some embodiments, a pressure and/or force label may be included on the vial. It may be desirable to include a pressure and/or force label for many reasons, including, but not limited to, determining whether a pressure/force was exerted onto the vial that may be indicative of an elevated volume of air saturation in the fluid, i.e., may indicate that there may have been an increase in the volume of dissolved air in the fluid which may lead to additional out-gassing of the air. This may, in some embodiments, be indicative that the vial of fluid may be compromised and therefore, it may be desirable for a user/caregiver to know whether the vial has been compromised.

In various infusion device, for example, including those shown and described herein as well as in U.S. Patent No. 7,498,563, issued March 3, 2009 and entitled Optical Displacement Sensor for Infusion Devices (Attorney Docket No. D78); U.S. Patent No. 7,306,578, issued December 11, 2007 and entitled Loading Mechanism for Infusion Pump (Attorney Docket No. C54); PCT Application Serial No. PCT/US2009/060158, filed October 9, 2009 and entitled Infusion Pump Assembly, now Publication No. WO 2010/042814, published April 15, 2010 (Attorney Docket No. F51WO); U.S. Patent Application Serial No. 11/704,899, filed February 9, 2007 and entitled Fluid Delivery Systems and Methods, now U.S. Publication No. US-2007-0228071-A1 published October 4, 2007 (Attorney Docket No. E70); U.S. Patent Application Serial No. 12/347,985, filed December 31, 2008 and entitled

Infusion Pump Assembly, now U.S. Publication No. US-2009-0299277-A1 published December 3, 2009 (Attorney Docket No. G75); and U.S. Patent Application Serial No. 12/560,106 filed September 15, 2009 and entitled Systems and Methods for Fluid Delivery, now U.S. Publication No. US-2010-0185142-A1, published July 22, 2010 (Attorney Docket No. G47), which are all hereby incorporated herein by reference in their entireties, in some 5 embodiments, the disposable / reservoir portion of the infusion pump may include one or more coatings to mitigate air bubbles. The coatings may be applied to the fluid pathways within the disposable / reservoir portion and / or to the outside of the reservoir. With respect to coatings applied to the fluid pathways, in some embodiments, a coating may be 10 applied to change the surface tension properties such that the surface is more hydrophilic. Increasing the hydrophilic properties of the fluid path may alter the angle of contact between an air bubble and the fluid path surface, thus enabling mitigation of the air bubble by priming or pumping. In some embodiments, the coating may be applied to the hard plastic portion and / or the membrane portion.

15 With respect to the reservoir, in some embodiments, a coating may be applied to the outside of the reservoir. The coating may be selected to decrease the permeability of the reservoir thus, may decrease the incidence of air permeating the reservoir and therefore, may minimize and / or decrease and / or lessen the incidence the air bubbles in the reservoir. As the coating may be applied to the outside of the reservoir, the coating used may be 20 anything desired and is not limited to fluid compatible materials. In some embodiments, the coating may include, but is not limited to, one or more of the following: parylene and/or oil. In some embodiments, the reservoir may be coated on the outside and the coating may prevent air diffusion inward and water vapor diffusion outward. In some embodiments, the inside of the reservoir may be coated with a material, including, but not limited to, a 25 parylene and / or oil and / or a hydrophilic coating material made by SurModics, Inc. of Eden Prairie, Minnesota, U.S.A., or other hydrophilic coatings that may be compatible with the fluid in the reservoir. In some embodiments, this may be desirable to allow for air to move through the reservoir material.

Altimeter

30 Referring now to the various embodiments of infusion pumps including those described in U.S. Patent No. 7,498,563, issued March 3, 2009 and entitled Optical Displacement Sensor for Infusion Devices (Attorney Docket No. D78); U.S. Patent No. 7,306,578, issued December 11, 2007 and entitled Loading Mechanism for Infusion Pump (Attorney Docket No. C54); and PCT Application Serial No. PCT/US2009/060158, filed October 9, 2009 and entitled

Infusion Pump Assembly, now Publication No. WO 2010/042814, published April 15, 2010 (Attorney Docket No. F51WO), and those infusion pumps known in the art, in some embodiments, an altimeter may be introduced to the infusion pump.

Referring to U.S. Patent Application Serial No. 11/704,899, filed February 9, 2007 and
5 entitled Fluid Delivery Systems and Methods, now U.S. Publication No. US-2007-0228071-A1 published October 4, 2007 (Attorney Docket No. E70); and U.S. Patent Application Serial No. 12/347,985, filed December 31, 2008 and entitled Infusion Pump Assembly, now U.S. Publication No. US-2009-0299277-A1 published December 3, 2009 (Attorney Docket No. G75), which are both hereby incorporated herein by reference in their entireties, in some
10 embodiments, the altimeter may be used in Acoustic Volume Measurements, for example, for changing the dampening based on ambient pressure. Still referring to U.S. Patent Application Serial No. 11/704,899, filed February 9, 2007 and entitled Fluid Delivery Systems and Methods, now U.S. Publication No. US-2007-0228071-A1 published October 4, 2007 (Attorney Docket No. E70); and U.S. Patent Application Serial No. 12/347,985, filed
15 December 31, 2008 and entitled Infusion Pump Assembly, now U.S. Publication No. US-2009-0299277-A1 published December 3, 2009 (Attorney Docket No. G75), in some embodiments, the disposable / reservoir portion of the infusion pump may include an intravenous needle connected to the tubing, rather than an infusion set, as discussed in various embodiments. Thus, in some embodiments, the infusion pump may be used to
20 administer intravenously and is not limited to subcutaneous infusion. In some of these embodiments, the fluids infused may be those used to minimize bleeding, for example, but not limited to, morphine and / or blood pressure lowering medications and / or other similar therapeutics.

Cannula Detection

25 In some embodiments of some infusion pumps, the cannula may be inserted into the user such that the cannula may be located directly between the user's skin and the infusion pump. This presents some challenges including, but not limited to, determining when the cannula has become dislodged and determining an occlusion in the cannula.

In some embodiments, two electrode contacts may be used. One electrode contact
30 may be in located between the infusion pump and the user's skin and is in contact with the user's skin, the other that is in electrical contact with the infusion pump. An electrical path between the two electrodes is established. Using high impedance / low voltage, the impedance between the two electrodes is determined and tracked. If the impedance reaches a very high value, for example, "infinity", an occlusion and / or cannula

dislodgement may be inferred. The user may be alerted. This may be desirable because if there is cannula dislodgement, the user is no longer receiving their fluid therapy. In the case of an insulin pump, the user may experience a hyperglycemic event. Early detection and alerting of the user may increase the safety of these types of infusion pumps.

5 While the principles of the invention have been described herein, it is to be understood by those skilled in the art that this description is made only by way of example and not as a limitation as to the scope of the invention. Other embodiments are contemplated within the scope of the present invention in addition to the exemplary embodiments shown and described herein. Modifications and substitutions by one of ordinary skill in the art are considered to be
10 within the scope of the present invention.

What is claimed is:

1. A system comprising:
 - a fill adapter device comprising:
 - a heat exchanger comprising:
 - a heating element; and
 - 5 a fluid pathway, the fluid pathway fluidly connected to a filling needle input, whereby fluid enters the heat exchanger through the filling needle input and flows through the fluid pathway and whereby the fluid is heated by the heating element;
 - a reservoir including a plunger and a plunger rod; and
 - a filling needle configured to be removably attached to the reservoir;
 - 10 wherein the fill adapter is configured to be attached to a vial of fluid and wherein fluid from the vial flows through the fluid pathway and is heated and loaded into the reservoir through the filling needle.
2. The fill adapter of claim 1 further comprising a pump to pump fluid into the fluid pathway at a predetermined rate.
3. The fill adapter of claim 1 further comprising a check valve for metering fluid into the fluid pathway whereby the rate of flow of fluid through the heat exchanger is controller.
4. The fill adapter of claim 1 further comprising a processor for controlling the heating of the fluid according to one or more preprogrammed profiles.
5. The fill adapter of claim 1 wherein the filling needle input is a septum.
6. The fill adapter of claim 1 further comprising an air trap whereby the air trap allows air to flow out of the heat exchanger.
7. The fill adapter of claim 6 wherein the air trap comprising a hydrophobic filter.
- 15 8. A fill adapter device comprising:
 - a heat exchanger comprising:

a heating element; and

a fluid pathway, the fluid pathway fluidly connected to a filling needle input and a vial, whereby fluid from the vial enters the heat exchanger and flows through the fluid pathway and whereby the fluid is heated by the heating element.

9. The fill adapter of claim 8 further comprising a pump to pump fluid into the fluid pathway at a predetermined rate.

10. The fill adapter of claim 8 further comprising a check valve for metering fluid into the fluid pathway whereby the rate of flow of fluid through the heat exchanger is controller.

11. The fill adapter of claim 8 further comprising a processor for controlling the heating of the fluid according to one or more preprogrammed profiles.

12. The fill adapter of claim 8 further comprising wherein the fill adapter is configured to be attached to a vial of fluid.

13. The fill adapter of claim 8 wherein the filling needle input is a septum.

14. The fill adapter of claim 8 further comprising an air trap whereby the air trap allows air to flow out of the heat exchanger.

15. The fill adapter of claim 14 wherein the air trap comprising a hydrophobic filter.

5

16. A method for atmospheric mitigation in an infusion pump comprising:

a pressure sensor sending data to a pump processor at a predetermined interval;

determining if the data exceeds an alarm threshold;

if the data exceeds a predetermined alarm threshold, the processor indicating to the

10 user to disconnect from a cannula;

determining if the data meets a pre-determined safe threshold; and

indicating to the user to re-connect to the cannula.

17. An infusion pump system comprising:

15 a reservoir;

an active check valve located downstream from the reservoir and upstream from a cannula;

a passive check valve having a cracking pressure located downstream from the reservoir; and

5 a pump processor, wherein the active check valve is opened by the pump processor for scheduled pump deliveries;

wherein when fluid pressure overcomes the cracking pressure, the passive check valve opens, and fluid flows from the reservoir and through the passive check valve.

10 18. An infusion pump system comprising:

a reservoir; and

at least one valve downstream from the reservoir wherein at least one valve is a pressure compensation valve having a cracking pressure wherein a differential pressure related to the change a altitude of the infusion pump causes the at least one valve to open.

15

19. A method for atmospheric mitigation in an infusion pump comprising:

receiving information related to a scheduled departure and a scheduled landing time;

modifying the frequency of processing data related to altitude based on the information;

20 determining, by comparing the information and the altimeter, whether a change in schedule may be occurring;

alerting a user of a change of schedule;

requesting updated schedule information; and

25 modifying the scheduled delivery of fluid based on the entered schedule a altimeter data.

20. An infusion pump system comprising:

a reservoir comprising a plunger;

at least one sensor for determining the location of the plunger; and

30 a processor configured to receive information from the at least one sensor and configured to modify the frequency of determination of the location of the plunger and configured to:

determine the volume of fluid either siphoned into or delivered out of a reservoir; and

modify scheduled pump deliveries for a predetermined amount of time.

21. A system for temperature compensation for an infusion pump, the system comprising:
at least one temperature sensor; and
at least one processor, the processor in communication with the temperature sensor,

wherein the processor determines a target plunger position and, based at least upon communication from the temperature sensor, modifies the target plunger position based on the temperature sensed.

22. A system for pressure mitigation for an infusion pump, the system comprising:
at least one pressure sensor; and
a processor, wherein the pressure sensor sends data to the processor and the processor mitigates pressure changes if the pressure changes meet a preprogrammed threshold.

1/14

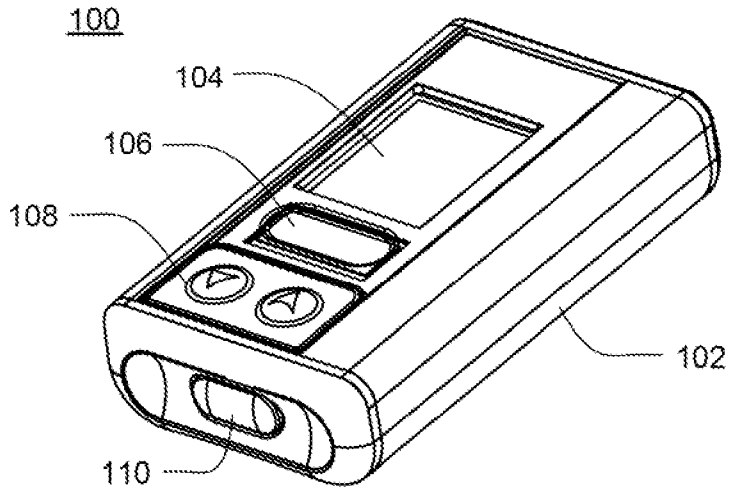

FIG. 1A

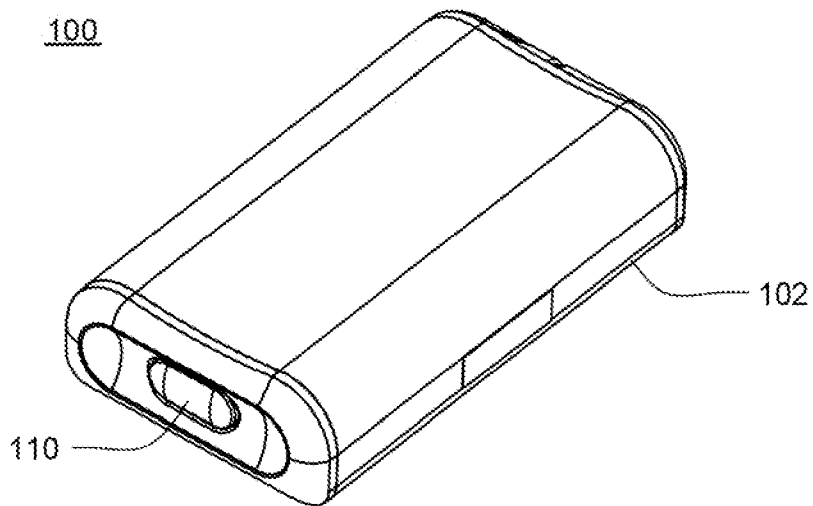

FIG. 1B

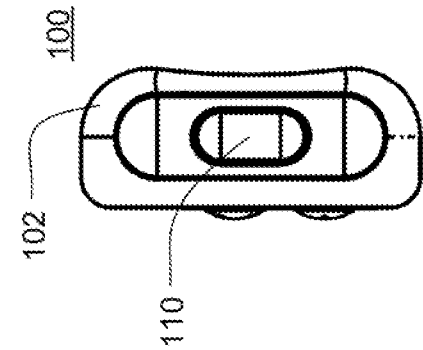

FIG. 1E

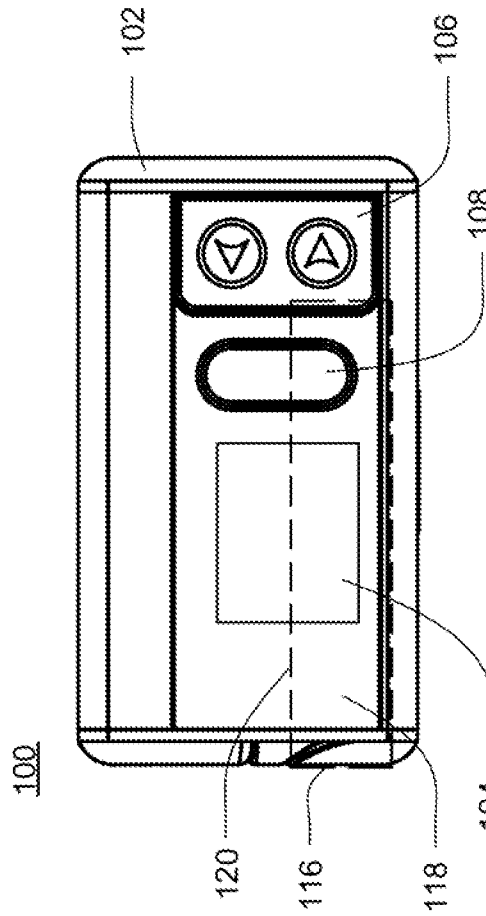

FIG. 1D

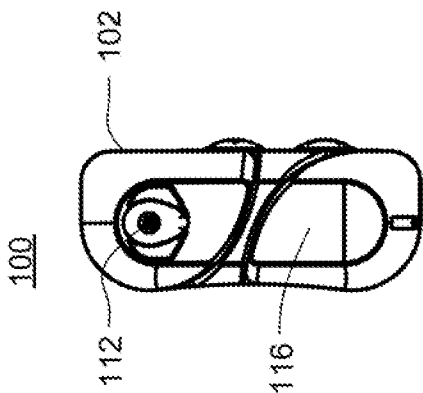

FIG. 1C

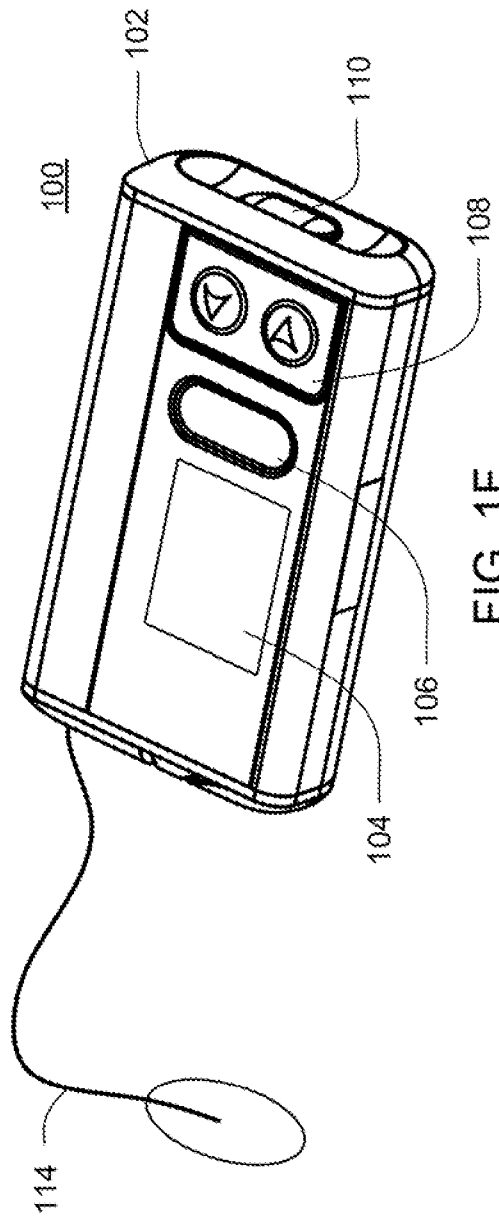

FIG. 1F

3/14

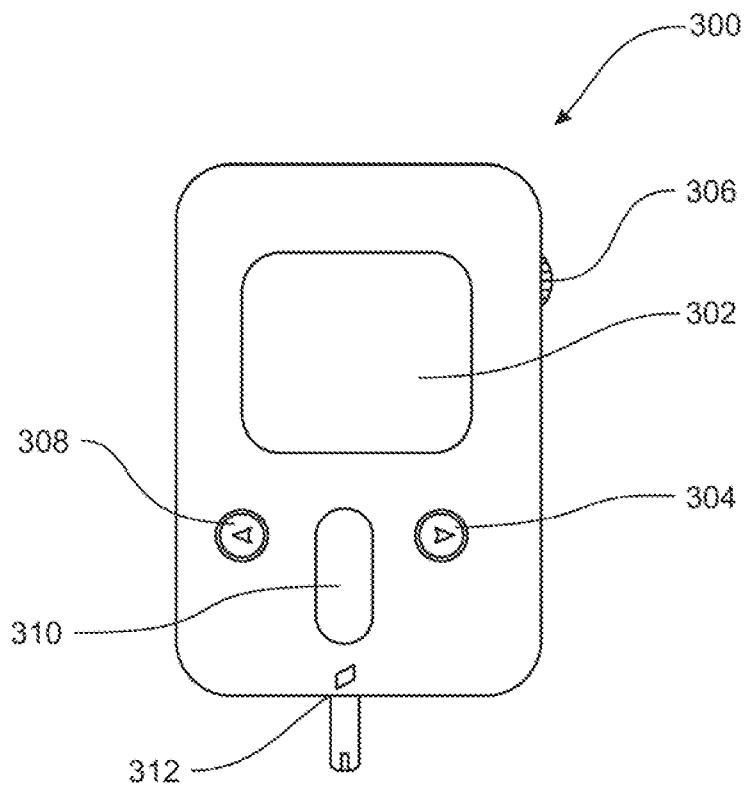

FIG. 3

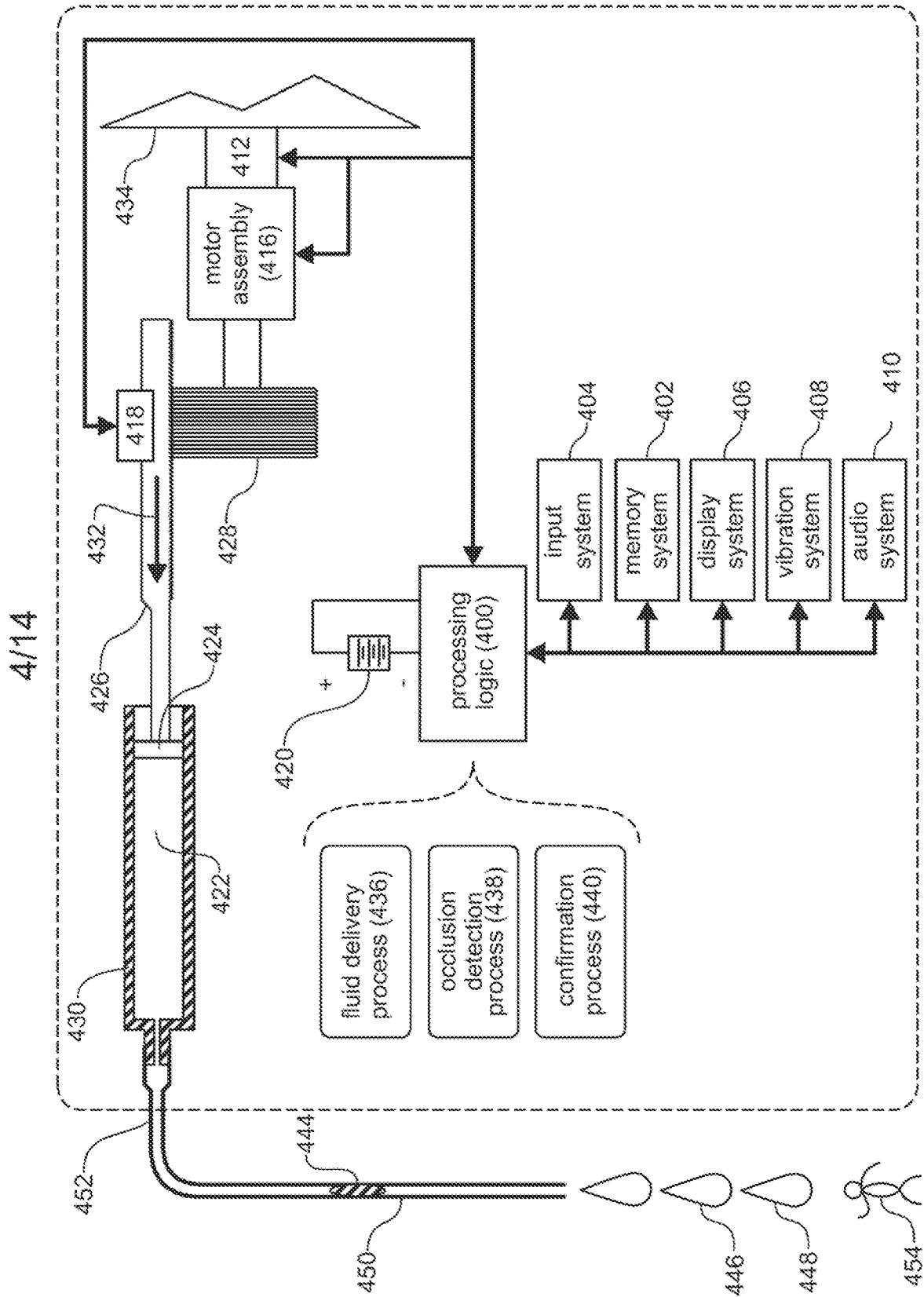

FIG.4

5/14

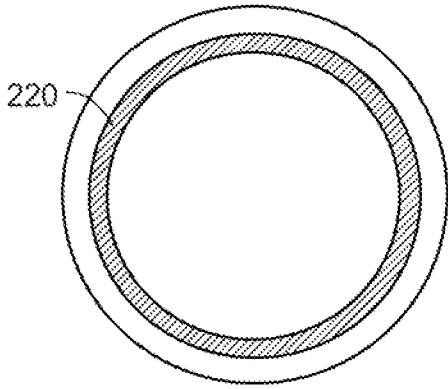

FIG. 10A

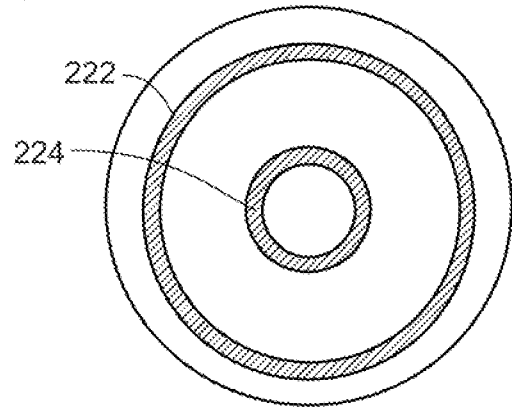

FIG. 10B

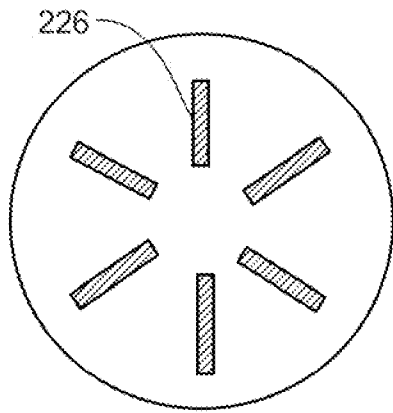

FIG. 10C

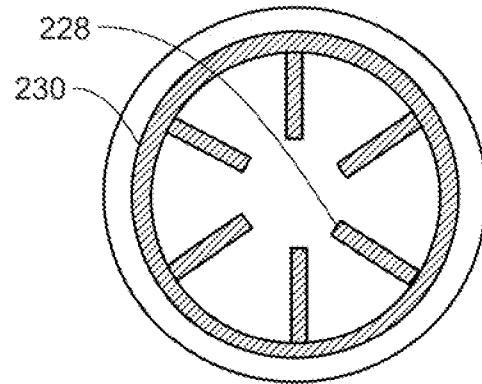

FIG. 10D

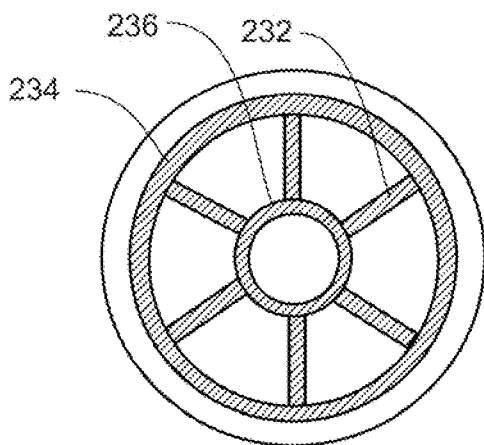

FIG. 10E

6/14

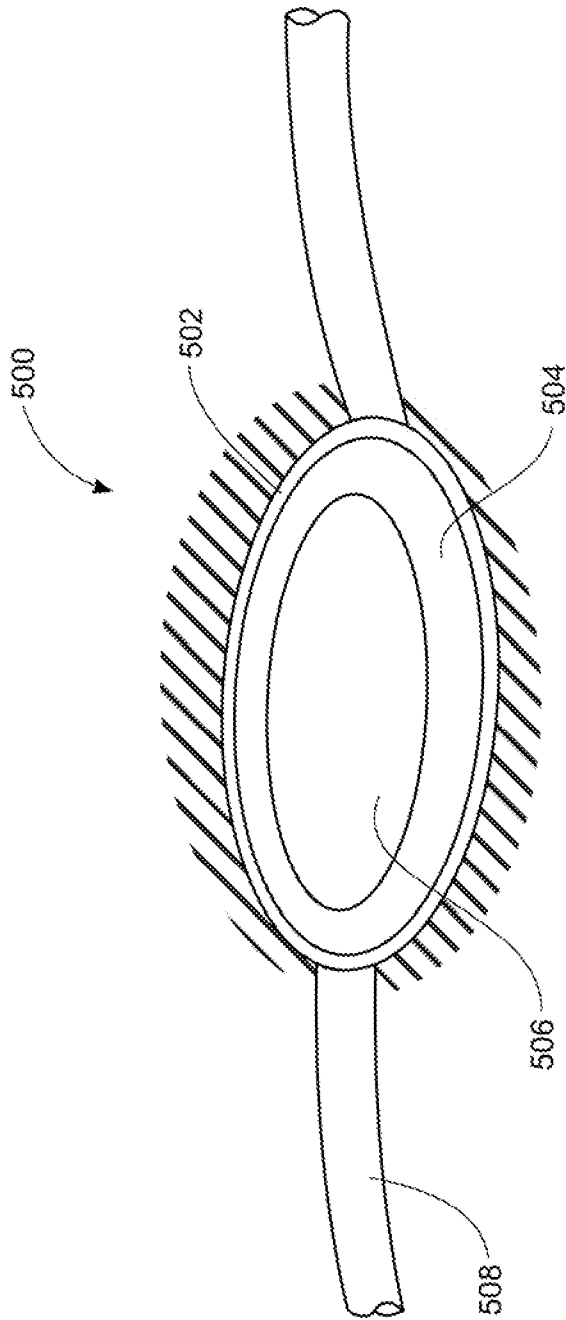

FIG. 11

7/14

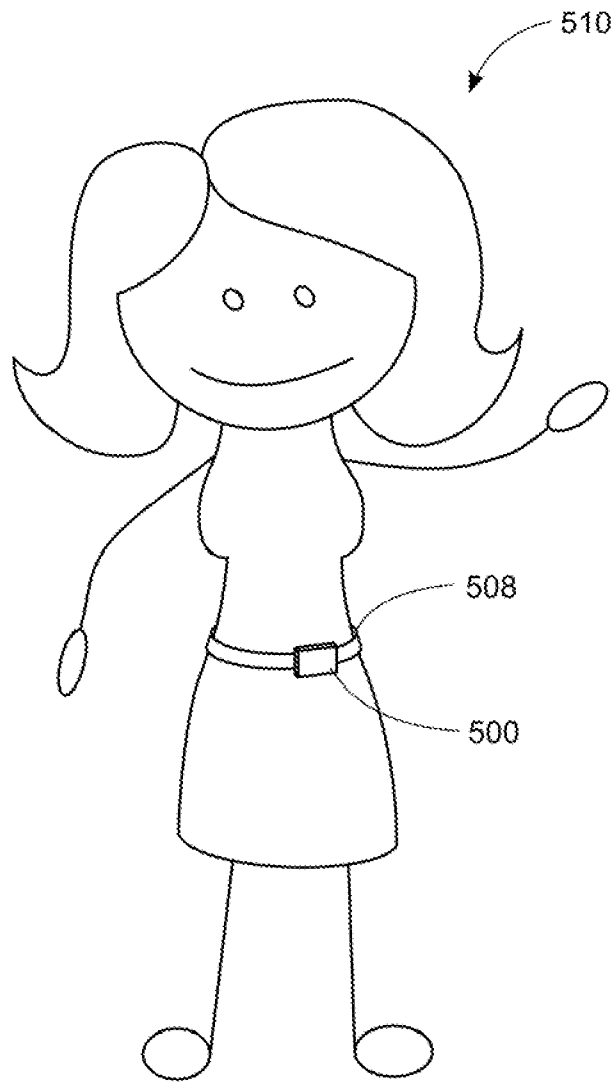

FIG. 12

8/14

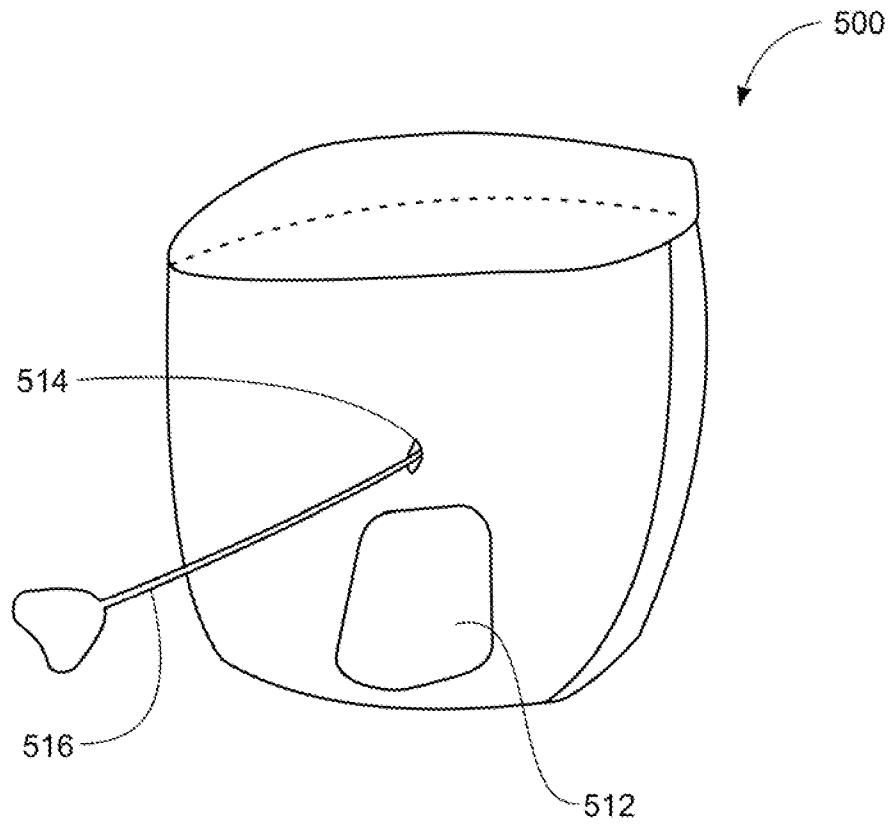

FIG. 13

9/14

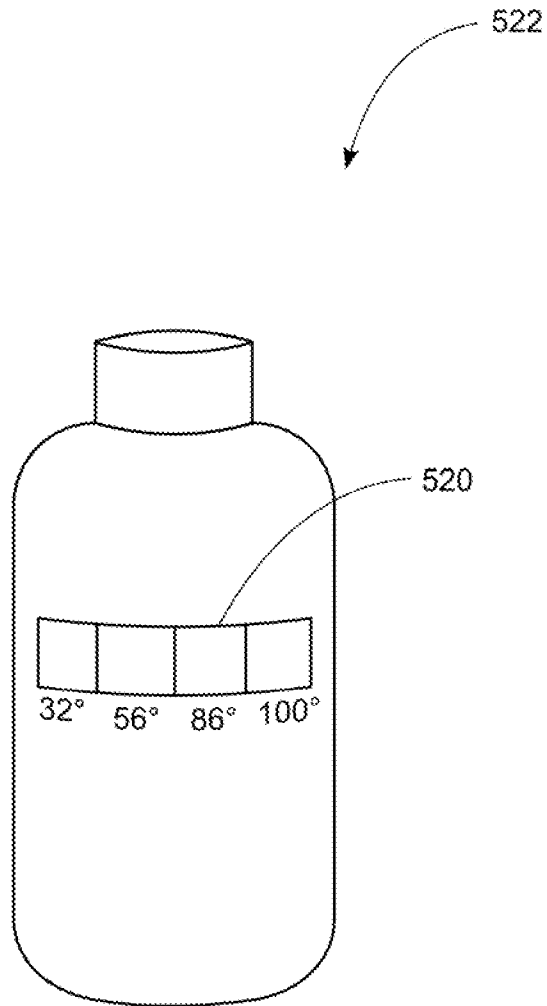

FIG. 14

10/14

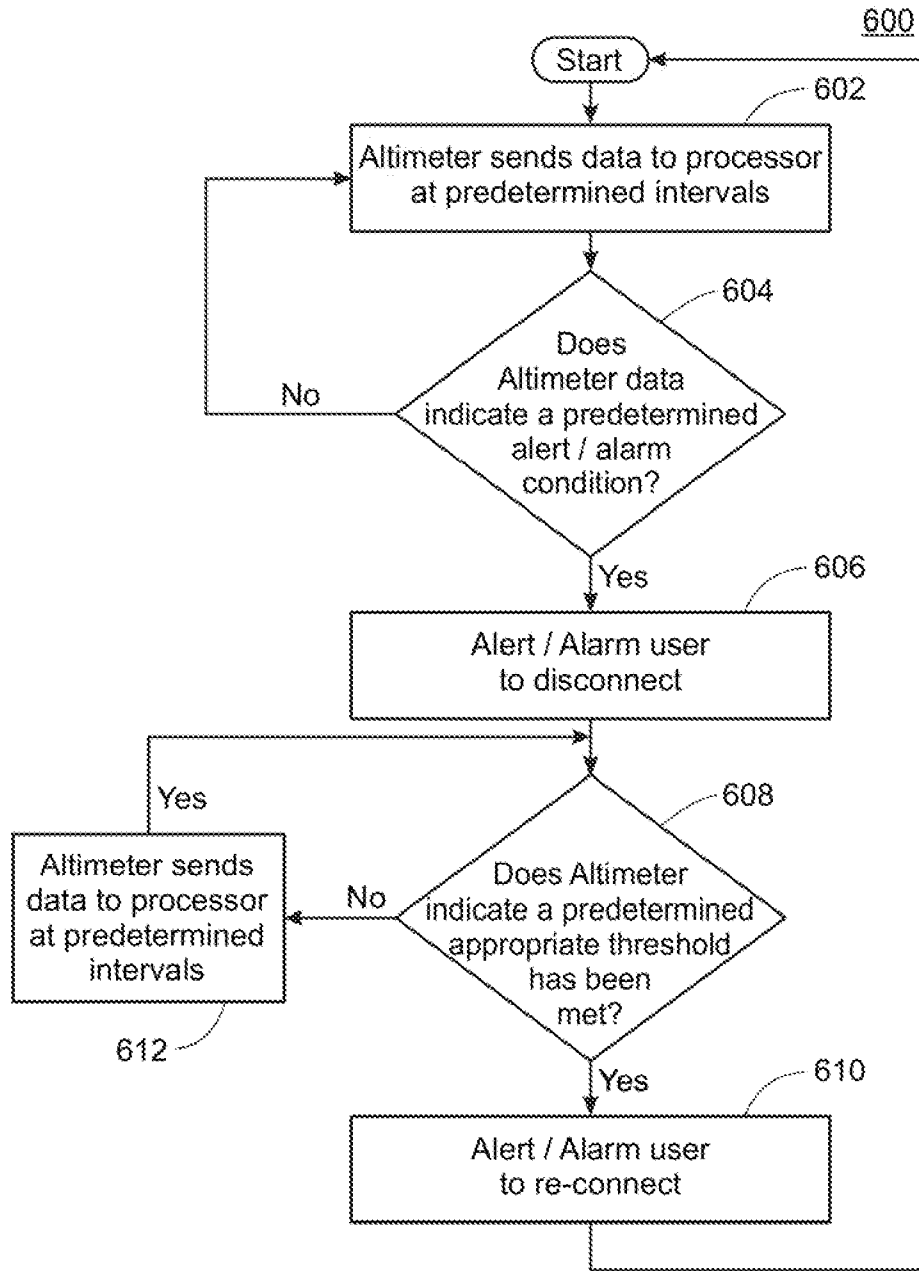

FIG. 15

11/14

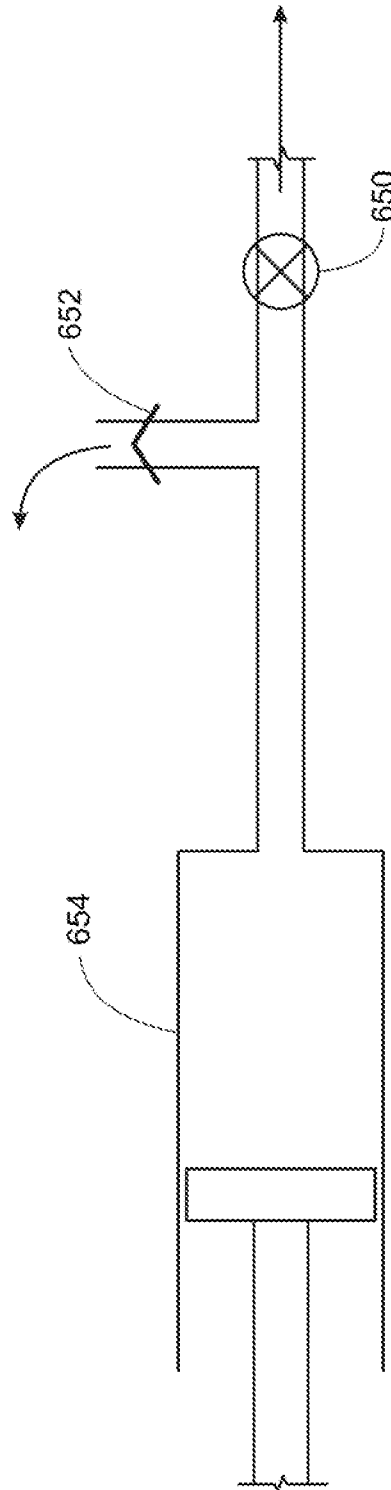

FIG. 16

12/14

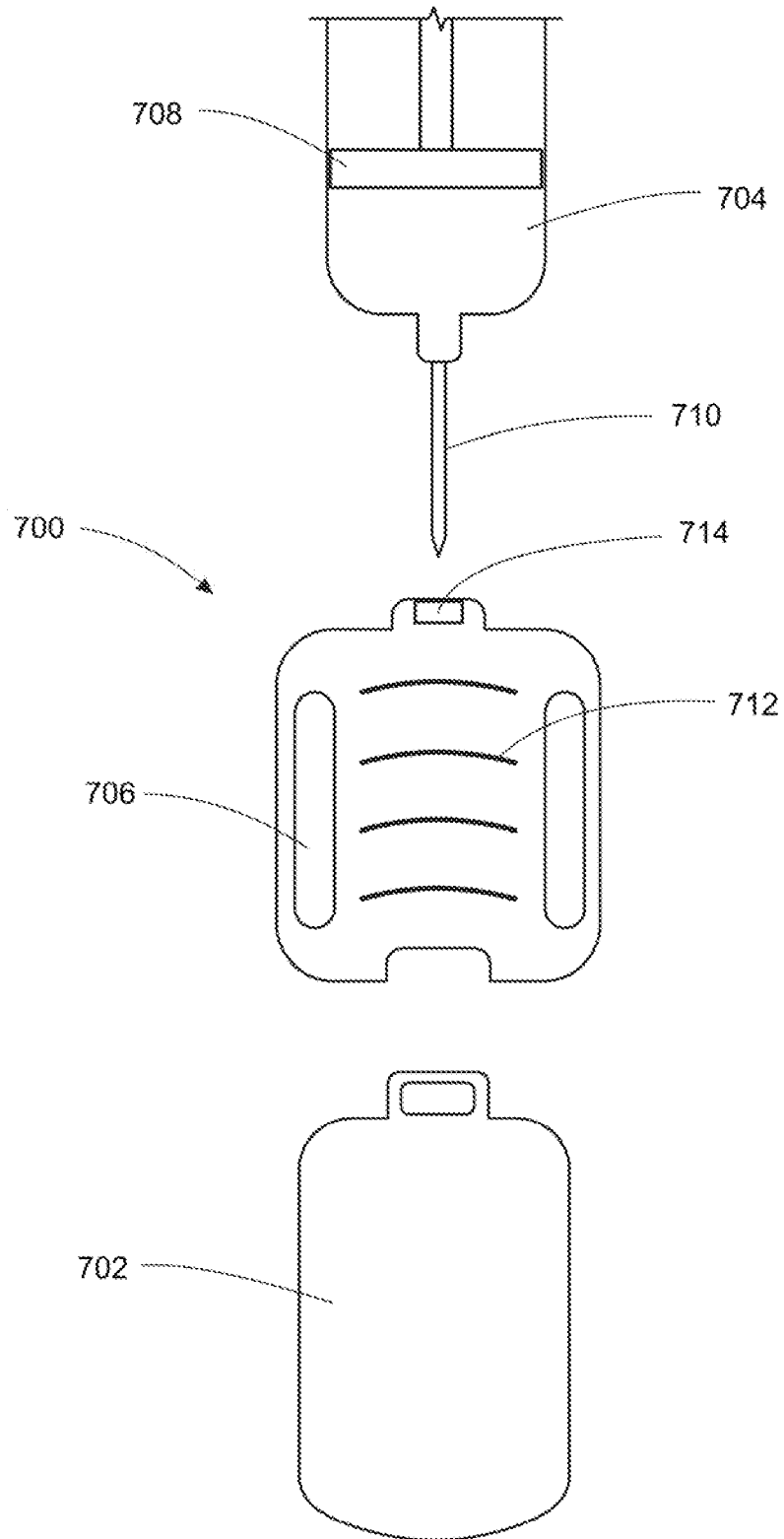

FIG. 17

13/14

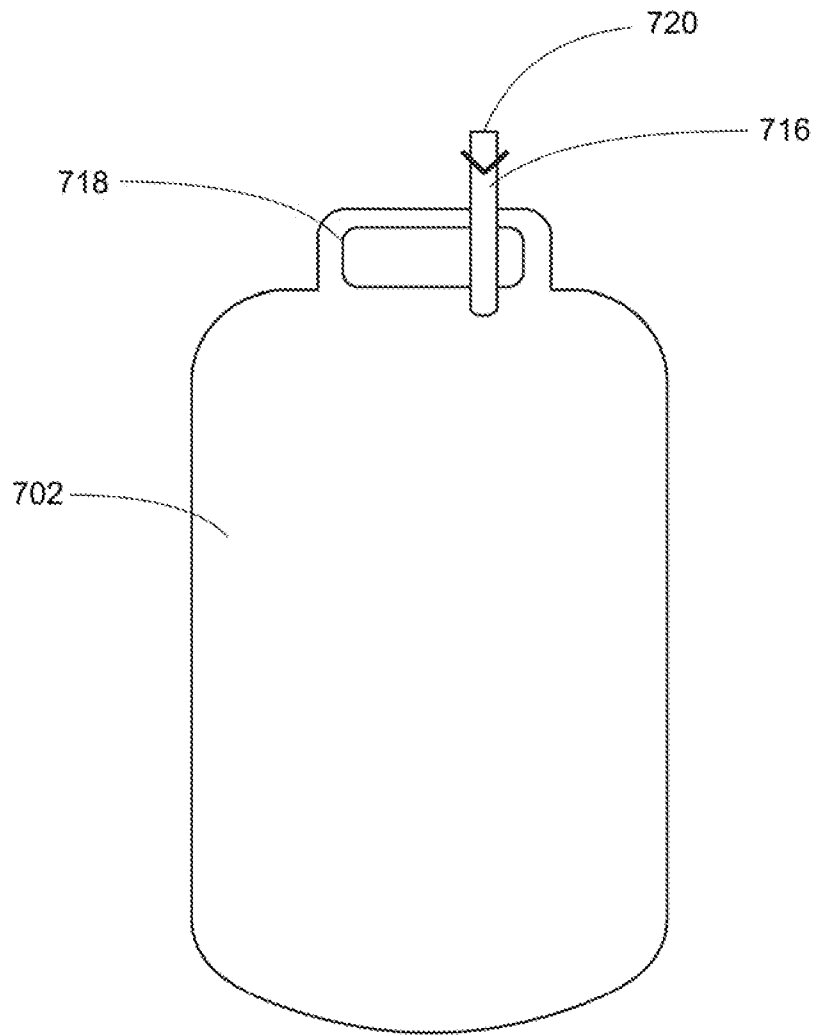

FIG. 18

14/14

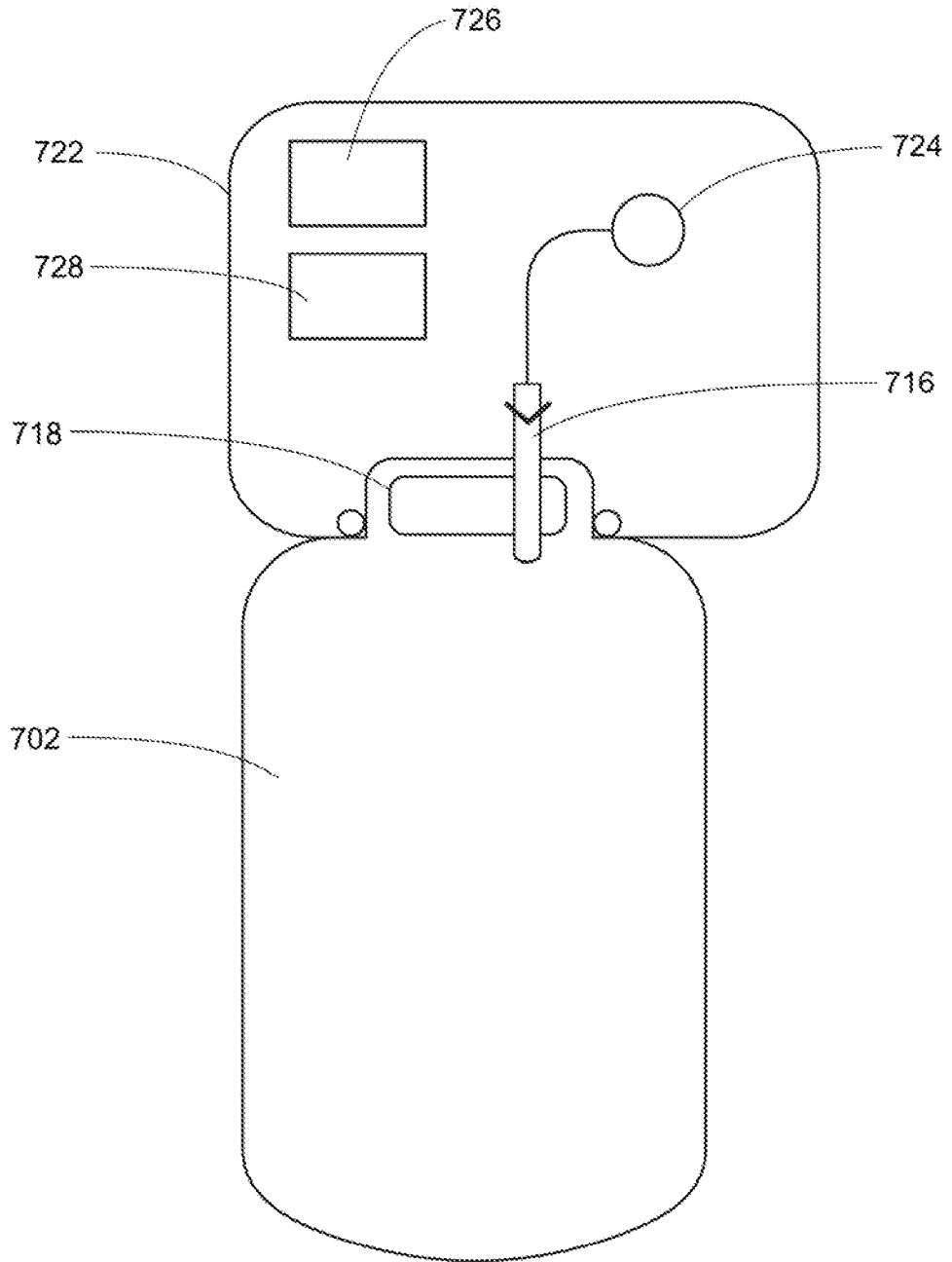

FIG. 19