

(No Model.)

C. H. CURTIS.
METAL LATHING.

No. 460,850.

Patented Oct. 6, 1891.

Fig. 1.

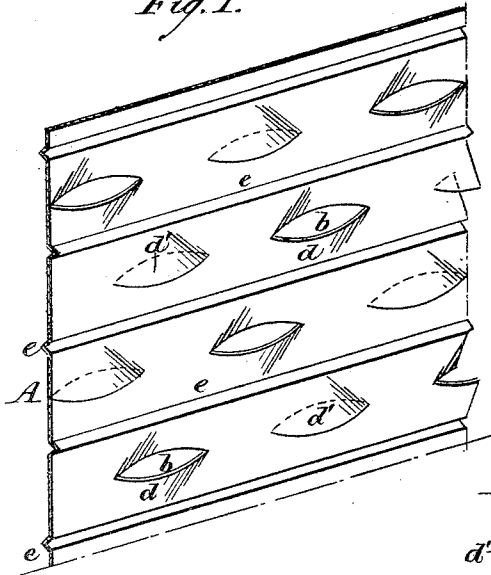

Fig. 2.

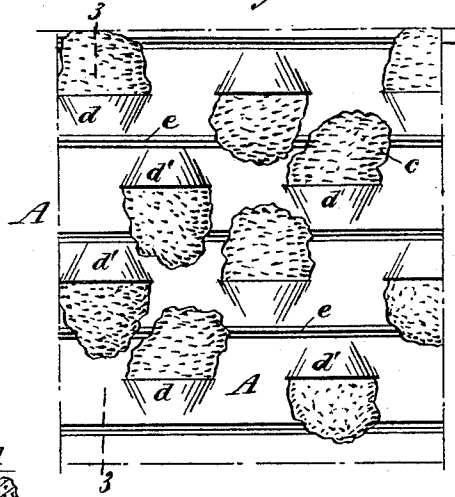

Fig. 3.

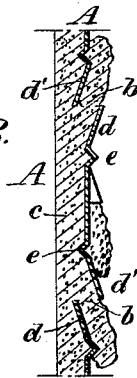
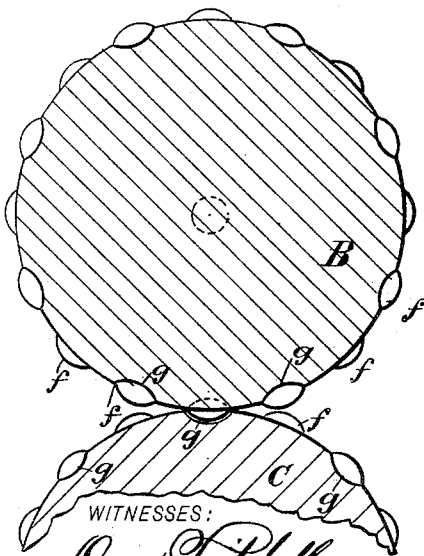

Fig. 4.



WITNESSES:

Donn Twitchell.
C. Sedgwick

Fig. 5.

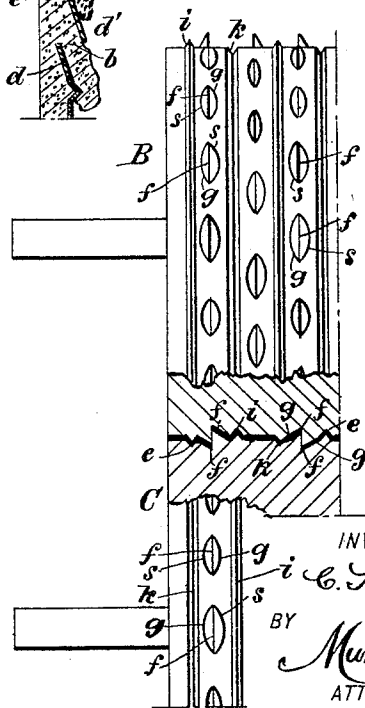

INVENTOR:

C. H. Curtis
BY *Munn & Co.*
ATTORNEYS

UNITED STATES PATENT OFFICE.

CHARLES HENRY CURTIS, OF NILES, OHIO.

METAL LATHING.

SPECIFICATION forming part of Letters Patent No. 460,850, dated October 6, 1891.

Application filed March 30, 1891. Serial No. 386,980. (No model.)

To all whom it may concern:

Be it known that I, CHARLES HENRY CURTIS, of Niles, in the county of Trumbull and State of Ohio, have invented a new and useful Improvement in Metal Lathing, of which the following is a full, clear, and exact description.

This invention relates to that description of metal lathing which is constructed of sheet metal having cuts made in it forming openings for entry and clinching of the plaster and in which the cut portions remain attached and are bent to protrude beyond the surface of the sheet, which is made corrugated in addition, to give strength.

The object of my invention is to produce a simple, easily manufactured, and improved fire and vermin proof metal lath of this description, substantially as hereinafter described, and more particularly pointed out in the claims.

Reference is to be had to the accompanying drawings, forming a part of this specification, in which similar letters of reference indicate corresponding parts in all the figures.

Figure 1 represents a view in perspective of a piece of sheet-metal lath or lathing constructed in accordance with my invention, said view showing the same before as when in use the plaster is applied to it. Fig. 2 is a rear face view of the same after the plaster has been applied to it. Fig. 3 is a transverse section upon the line 3 3 in Fig. 2. Fig. 4 is a transverse section of a pair of rolls in part with attached knives used in producing the lath, and Fig. 5 is a longitudinal or side elevation of said rolls or devices in part with the adjacent or meeting portions of the rolls in section.

A indicates a piece of my improved sheet-metal lath and which may be of any desired length, width, and thickness. The holes *b* in the plate for reception and clinching of the plaster *c* are made in parallel rows at any suitable distance apart and preferably the one row of holes made intermediate of the next adjacent row of holes. These holes, so far as the cutting of them is concerned, are each made by a single sharp incision without removing metal, yet have a large capacity, not running directly or straight through the sheet or plate, but obliquely therethrough or

laterally to the incisions and extending to both or opposite sides of the plate, which is effected by indenting the plate in reverse directions from opposite sides of it, thereby forming reverse curved hoods *d d'* on reverse sides of the plate on opposite sides of each incision. By thus forming the holes or openings through the sheet or plate which constitutes the lath of an enlarged capacity extending obliquely to opposite sides of it a large connecting body of solid plaster to establish the clinch is projected through the lath, as shown in Figs. 2 and 3, which, as it will be seen, is not as liable to loosen as a smaller connecting and clinching body of plaster would be. In addition to this the metal sheet or lath is corrugated to give strength by forming it with ribs *e* of approximately V shape in transverse section between and parallel with the openings *b* and so that each succeeding rib or corrugation is on reverse sides of the sheet or lath. This feature, in connection with the openings made successively or alternately, as described, leaves the lath with no special up or down face or right or left hand side, consequently there need be no delay or trouble in turning a sheet in order to fit one previously put on.

To produce this improved metal lath the sheet of metal forming it is passed between two rolls B C. These rolls are fitted on their peripheral surface with projecting knives, shears, or cutters *f f*, arranged at a suitable distance apart around the rolls and from each other in direction of the length of the rolls to make incisions in the sheet for production of the openings *b* in the latter, arranged as described, and said knives *f f* made with shelving backs *s* and the rolls made with correspondingly-shaped depressions *g* for said backs to work into as the rolls, suitably geared and working in proper housings, rotate in common, in order to form the hoods *d d'* on the sheet, which virtually form the openings *b b* through the sheet. Moreover, as these hoods *d d'* are on reverse sides of the sheet for each opening and on opposite sides of each incision, but respectively on the same side of the sheet for every alternate opening in the same row, the knives, which by their meeting edges and faces as the two rolls rotate in common shear the metal to make the incision, are

arranged to successively face in opposite directions on each roll, whereby only every alternate hood d or d' is made to open on the same side of the sheet in the same direction.

5 To produce the V-shaped corrugations or ribs e successively on reverse sides of the sheet between the rows of openings b , each roll B C is constructed on its periphery alternately with V-shaped annular beads or ribs i and

10 annular correspondingly-shaped grooves k on opposite sides of or between the annular rows of knives thereon, and so that the annular grooves i of either roll come opposite the annular beads k of the other roll.

15 The lath thus made is very rapidly and easily produced, admits of a large number of openings for the plaster being made within a given space with, it may be said, double the

20 the outer surface portion of the plaster with the clinching portion, yet with a very small amount of plaster passing through and falling behind the lath, but sufficient to hold the plaster firmly on account of the large solid

25 body connecting through the lath.

Having thus fully described my invention, I claim as new and desire to secure by Letters Patent—

1. A metal lath consisting of a piece of metal having openings running laterally and obliquely through it formed by longitudinal divisions in the metal and reverse lateral oblique depressions, leaving oppositely-arranged hoods on reverse sides of the body of the lath, whereby provision is made for passage within or through the lath of an enlarged body of mortar or plaster extended to form a clinch, substantially as specified.

2. A sheet-metal lath having a series of openings running laterally and obliquely through it, leaving oppositely-arranged hoods on reverse sides of the sheet, each successive opening in the same line or row having its hood upon either one and the same side of the sheet-face in a reverse direction to that of the hood of the next opening, essentially as described.

3. A sheet-metal lath constructed with a series of openings and parallel V-shaped corrugations having their salient surfaces successively on reverse sides of the sheet, substantially as specified.

CHARLES HENRY CURTIS.

Witnesses:

W. DE P. KNOWLTON,
PAUL H. HUBBARD.