



(43) International Publication Date
18 September 2014 (18.09.2014)

- (51) International Patent Classification:
A61M 5/32 (2006.01)
- (21) International Application Number:
PCT/US2013/072222
- (22) International Filing Date:
27 November 2013 (27.11.2013)
- (25) Filing Language: English
- (26) Publication Language: English
- (30) Priority Data:
13/841,462 15 March 2013 (15.03.2013) US
- (71) Applicant: **RETRACTABLE TECHNOLOGIES, INC.**
[US/US]; 511 Lobo Lane, Little Elm, TX 75068 (US).
- (72) Inventor; and
(71) Applicant : **SHAW, Thomas, J.** [US/US]; 5310 Buena Vista Dr., Frisco, TX 75034 (US).
- (72) Inventors: **SMALL, Mark**; 47442 Caughern Lane, Heavener, OK 74937 (US). **ZHU, Ni**; 4408 Brigade Ct., Plano, TX 75024 (US).
- (74) Agent: **ROSS, Monty, L.**; Ross Barnes LLP, 801 E. Campbell Rd., Ste. 390, Richardson, TX 75081 (US).

(81) Designated States (unless otherwise indicated, for every kind of national protection available): AE, AG, AL, AM, AO, AT, AU, AZ, BA, BB, BG, BH, BN, BR, BW, BY, BZ, CA, CH, CL, CN, CO, CR, CU, CZ, DE, DK, DM, DO, DZ, EC, EE, EG, ES, FI, GB, GD, GE, GH, GM, GT, HN, HR, HU, ID, IL, IN, IR, IS, JP, KE, KG, KN, KP, KR, KZ, LA, LC, LK, LR, LS, LT, LU, LY, MA, MD, ME, MG, MK, MN, MW, MX, MY, MZ, NA, NG, NI, NO, NZ, OM, PA, PE, PG, PH, PL, PT, QA, RO, RS, RU, RW, SA, SC, SD, SE, SG, SK, SL, SM, ST, SV, SY, TH, TJ, TM, TN, TR, TT, TZ, UA, UG, US, UZ, VC, VN, ZA, ZM, ZW.

(84) Designated States (unless otherwise indicated, for every kind of regional protection available): ARIPO (BW, GH, GM, KE, LR, LS, MW, MZ, NA, RW, SD, SL, SZ, TZ, UG, ZM, ZW), Eurasian (AM, AZ, BY, KG, KZ, RU, TJ, TM), European (AL, AT, BE, BG, CH, CY, CZ, DE, DK, EE, ES, FI, FR, GB, GR, HR, HU, IE, IS, IT, LT, LU, LV, MC, MK, MT, NL, NO, PL, PT, RO, RS, SE, SI, SK, SM, TR), OAPI (BF, BJ, CF, CG, CI, CM, GA, GN, GQ, GW, KM, ML, MR, NE, SN, TD, TG).

Published:

— with international search report (Art. 21(3))

(54) Title: NEEDLE RETRACTION APPARATUS

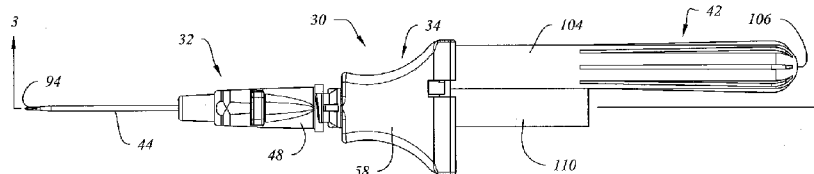

FIG. 1

(57) Abstract: A needle retraction apparatus comprising a body having a forwardly projecting needle, a needle retraction mechanism seated inside the body and biasing the needle rearwardly relative to the body, a slide member attachable to the body and having an opening communicating with a needle retraction cavity projecting away from the body, and an actuator rotatable relative to the slide member to reposition the slide member from a first position preventing needle retraction to a second position permitting needle retraction. An IV catheter introducer comprising the subject needle retraction apparatus is also disclosed.

WO 2014/143220 A1

IN THE UNITED STATES PATENT AND TRADEMARK OFFICE**NEEDLE RETRACTION APPARATUS****CROSS-REFERENCE TO RELATED APPLICATION**

[0001] This application claims the benefit of U.S. Provisional Patent Application No. 61/737,263, filed December 14, 2012. This application is also a continuation-in part of U.S. Patent Application No. 12/846,402, filed July 29, 2010, insofar as Application No. 12/846,402 discloses a trigger or actuator that contacts and moves a lug along an arc defined by a rotatable lug ring, which movement aligns a shaped aperture with a correspondingly shaped flange on the needle holder to facilitate needle retraction.

BACKGROUND OF THE INVENTION

1. Field of the Invention

[0002] This invention relates to a safety needle retraction apparatus for medical devices and, more particularly, to a new safety needle retraction apparatus that is part of a catheter introducer for intravenous or other biomedical applications, or as part of another device useful for other fluid infusion or collection procedures.

[0003] One aspect of the invention relates to an IV catheter introducer having a needle retraction apparatus that is rotationally activated. Another aspect of the invention relates to a needle retraction apparatus for a glass or plastic liquid infusion or collection device, the apparatus having a body, a needle retraction mechanism, and a forwardly facing, rearwardly biased needle.

[0004] Another aspect of the invention is a retractable needle apparatus that is also adapted to be use with a conventional catheter hub and cannula that are attachable to the front of the apparatus.

[0005] Another aspect of the invention relates to a rear slide assembly having a flash chamber and a substantially parallel and laterally spaced-apart needle retraction tube. The rear slide assembly is adapted to move transversely relative to the body as the needle retraction tube is rotated relative to the body to initiate needle retraction following fluid collection or infusion.

[0006] Another aspect of the invention relates to a method for retracting a needle in a medical device whereby rotating a needle retraction tube causes the needle retraction tube to be repositioned laterally into coaxial alignment with a rearwardly biased needle to facilitate retraction of the needle into the needle retraction tube.

2. Description of Related Art

[0007] U.S. Publ. No. 2006/0155244 to Popov discloses a venipuncture device that rotates a port unit following needle retraction. The needle retraction chamber is disposed inside the medical device and remains stable while the port unit is moved rotationally relative to the retraction chamber following needle retraction. The frontal attachment disclosed there cannot be used with a generic luer lock syringe.

[0008] Although many advancements in medical safety technology have been made in recent years, a retractable needle apparatus is needed that can be used in combination with other commercially available fluid collection or infusion devices such as the IV-catheter introducer described here. Such a device will desirably have a needle retraction chamber external to the fluid flow path and will offer the advantages of a retractable needle having sufficient retraction force.

SUMMARY OF THE INVENTION

[0009] A needle retraction apparatus is disclosed that comprises a body, a slide member attachable to the rear of the body, a needle retraction mechanism seated inside the body, a fluid seal seated between the body and the slide member, and a medical grade stainless steel (or approved equivalent) needle projecting forwardly from the body. According to one embodiment of the invention, the body comprises a centrally disposed, stepped axial bore, laterally projecting gripping surfaces, and a forwardly projecting nose to which a conventional catheter hub and cannula are releasably attachable.

[0010] According to one embodiment of the invention, the slide member comprises a forwardly facing surface that is configured to abut and move transversely in slidable relation to the rear of the housing during the needle retraction process. In one embodiment, the rear of the body comprises upper and lower tracks that slidably engage the major transverse portion of the slide member. The slide member desirably further comprises two laterally spaced openings, one of which serves as an opening into a flash chamber projecting rearwardly behind the forwardly facing surface, and another of which serves as an opening for a rearwardly projecting needle retraction tube that is substantially parallel to but spaced laterally apart from the flash chamber.

[0011] The flash chamber is desirably aligned initially with the needle holder, and is preferably transparent or sufficiently translucent that medical personnel using the device can readily determine whether vascular access has been achieved during insertion. A polymeric plug or other suitable apparatus is desirably installed at the rear of the flash chamber to facilitate fluid infusion or collection through the flash chamber. The plug can be pierceable or can be provided with a continuous bore to facilitate connection to other fluid collection or infusion apparatus.

[0012] The needle retraction tube is desirably supported by the slide member but is rotatable in relation to the slide member to facilitate lateral repositioning of the needle retraction tube during the needle retraction process.

According to one embodiment of the invention, the needle retraction tube desirably has an open front end and a closed rear end, and comprises an annular flange disposed around the open end. The annular flange preferably comprises a forwardly projecting lug that is received into a cooperatively aligned positioning notch in the body during assembly. As the needle retraction tube is rotated to initiate needle retraction, the forwardly projecting lug moves arcuately around the longitudinal axis of the retraction tube and engages the sides of the repositioning notch in the body, which causes the slide member to move transversely relative to the body, thereby placing the needle retraction tube in substantially coaxial alignment with the needle holder and needle.

[0013] According to one embodiment of the invention, the needle retraction mechanism comprises an elongate needle holder that is receivable into the axial bore of the body and captures a compressed retraction spring inside the body. Other similarly effective means for biasing the needle holder and needle rearwardly can also be used. The needle holder is desirably restrained inside the housing prior to needle retraction by the facing and abutting slide member, and a fluid seal is desirably disposed between the rearwardly facing head of the needle holder and a forwardly facing annular recess in the opening into the flash chamber.

[0014] The needle retraction apparatus of the invention can be provided separately from or in combination with the catheter hub, but is desirably provided with the catheter hub already installed onto the body. According to one satisfactory method of using the invention, the protective cap (not shown) is removed from the front of the needle and catheter hub, and with the forwardly projecting lug of the needle retraction tube positioning the flash chamber in substantially coaxial alignment with the needle holder and needle, the needle is inserted into a patient. If blood appears in the flash chamber, this signifies successful vascular insertion. The needle can be retracted from the cannula and into the apparatus by rotating the needle retraction tube relative to the body to reposition the needle retraction tube into coaxial alignment with the needle holder. Once the point of coaxial alignment is reached, the rearwardly biased

needle holder is propelled rearwardly into a retraction cavity inside the needle retraction tube. At this point the catheter hub is available for connection to another apparatus such as an IV set.

BRIEF DESCRIPTION OF THE DRAWINGS

[0015] The apparatus of the invention is further described and explained in relation to the following drawings wherein:

FIG. 1 is a top plan view of one embodiment of an apparatus of the invention with the needle projecting forwardly from the needle hub of the apparatus in coaxial alignment with the flash chamber tube of the apparatus;

FIG. 2 is a side elevation view the embodiment of FIG. 1;

FIG. 3 is a cross-sectional side elevation view taken along line 3—3 of FIG. 1;

FIG. 4 is an exploded front perspective view of the embodiment of FIG. 1;

FIG. 5 is a cross-sectional top plan view of the embodiment of FIG. 1 with following needle retraction and with the needle retraction tube repositioned into coaxial alignment with the needle hub;

FIG. 6 is a side elevation view of the embodiment of FIG. 5; and

FIG. 7 is a cross-sectional side elevation of the embodiment of FIG. 1 showing the needle holder and at least a portion of the needle and retraction spring retracted into the needle retraction cavity;

FIG. 8 is a rear elevation view of the apparatus of FIG. 1;

FIGS. 9 and 10 are rear elevation views of the of the apparatus of FIG. 1 wherein the needle retraction tube has been rotated sufficiently to cause the rear slide assembly to begin repositioning the needle retraction tube into coaxial alignment with the needle holder; and

FIG. 11 is a rear elevation view of the apparatus of FIG. 1 with the needle retraction tube fully repositioned to the retraction position.

DESCRIPTION OF THE PREFERRED EMBODIMENTS

[0016] FIGS. 1-4 disclose an IV catheter introducer 30 that comprises the needle retraction apparatus of the invention, which further comprises body 34, forwardly projecting needle 78 (FIG. 4) with beveled tip 94, needle retraction mechanism 36, slide member 38, and needle retraction tube 42. Referring to FIGS. 1-4, catheter hub assembly 32 is a conventional IV catheter hub that is releasably attachable to body 34 and includes a forwardly facing flexible sheath or cannula 44 through which needle 78 is inserted to facilitate vascular insertion. Needle retraction mechanism 36 is seated inside body 34, and is held in place by slide member 38 (FIG. 4) into which needle retraction tube 42 is inserted prior to being slidably engaged with the rear of body 34 during assembly. It will also be appreciated by those of ordinary skill in the art upon reading this disclosure that the needle retraction apparatus of the invention is readily adaptable for use with other medical devices in which a retractable needle and a rotationally activated needle retraction mechanism are desired.

[0017] As depicted, catheter hub 32 further comprises hub nose 46 projecting forwardly from substantially cylindrical barrel 48 that also has a rear opening surrounded by annular attachment collar 50 comprising opposed lugs 52, 54. The inside of annular attachment collar 50 and barrel 48 desirably comprises a tapered female luer surface configured to provide fluid-tight frictional engagement with forwardly projecting male luer tip 56 of body 34.

[0018] Body 34 comprises a stepped inside surface (FIG. 3) and has outside gripping surfaces 58 desirably configured to be easily graspable by a clinician during vascular insertion. The rear portion of body 34 preferably comprises laterally extending upper track 60 and lower track 62 that are desirably configured to slidably engage and retain forwardly facing frame 80 of slide member 38 in close proximity to body 34. A positioning notch 64 is desirably provided at the rear of body 34 to facilitate engagement with forwardly projecting lug 102 of needle retraction tube 42 as further described below in relation to operation of the device.

[0019] Needle retraction mechanism 36 comprising needle holder 70 and spring 76 (depicted in its compressed state to save space for illustrative purposes in FIG. 4 rather than relaxed as shown in FIG. 7) is desirably seated in the stepped cylindrical interior of body 34. Needle holder 70 as shown comprises elongate cylindrical shaft 72 and a larger-diameter head 74. The outside diameter of shaft 72 is desirably slightly less than the inside diameter of coiled spring 76 to permit insertion of shaft 72 through the coiled spring. A continuous axial bore 92 desirably extends through shaft 72 and head 74 of needle holder 70. The outside diameter of head 74 is desirably sufficiently larger than that of shaft 72 to provide a forwardly facing annular surface at the rear end of shaft 72 against which the rear end of spring 76 abuts when compressed and installed inside body 34. The rearwardly facing end of the head 74 of needle holder 70 can comprise a slight recess to facilitate seating of fluid seal 68, although fluid seal 68 is desirably carried by slide member 38 during needle retraction as discussed below. Compressed spring 76 biases needle holder 70 rearwardly in relation to body 34, and needle holder 70 is retained inside body 34 against the spring bias by slide member 38 when slide member 38 is assembled to body 34. Although spring 76 is satisfactory for use in biasing needle holder rearwardly in relation to body 34, other similarly effective configurations can also be used. During assembly of the subject needle retraction apparatus, the rearwardly facing blunt end of needle 78 (FIG. 4) is desirably inserted into bore 92 of needle holder 70 from the front and is attached in fixed relation to needle holder 70 by any known suitable means, such as by gluing or the like.

[0020] Slide member 38 desirably comprises frame 80 and rearwardly projecting, substantially cylindrical fluid flash chamber 110 having an interior space into which fluid can flow from a patient through needle 78, needle holder 70 and aperture 90. Elastomeric plug 40 is desirably fitted into a rearwardly facing opening of flash chamber 110. The forwardly facing portion of slide member 38 desirably comprises first and second circular openings including apertures 90, 86, respectively. Opening 90 is provided rearwardly of annular recess 88 in forwardly facing surface 84. Annular recess 88 is provided for

seating fluid seal 68, which is preferably an elastomeric O-ring disposed between head 74 of needle holder 70 and slide member 38 to prevent fluid leakage during use and prior to needle retraction. Aperture 86 is provided in recessed surface section 82 to facilitate assembly of needle retraction tube 42 with slide member 38.

[0021] Needle retraction tube 42 desirably comprises a first tubular section 104 having a forwardly facing open end 98 surrounded by radially projecting annular collar 100, and a second tubular section 108 having a closed end 106 projecting away from body 34. The substantially cylindrical interior space of needle retraction tube 42 serves as a retraction cavity. A plurality of ribs (or other similarly effective surface texturing) are desirably provided around section 108 to facilitate gripping needle retraction tube 42 to rotate needle retraction tube 42 relative to body 34 to initiate needle retraction. Forwardly projecting lug 102 is desirably provided at the front of needle retraction tube 42, and is desirably cooperatively aligned with positioning notch 64 in body 34. During assembly, needle retraction tube 42 is desirably inserted into aperture 86 from the front of slide member 38 so that tube 42 is rotatable around its longitudinal axis when mounted in slide member 38 and so that the front face of annular collar 100 (except for lug 102) is substantially flush with forwardly facing surface 84 of slide member 38.

[0022] Referring to FIGS. 1-3, when IV catheter introducer 80 is fully assembled, and ready for use (with the needle cap removed), beveled needle tip 94 projects forwardly from cannula 44 and the central longitudinal axis of flash chamber 110 is aligned with the longitudinal axis of the needle. Referring to FIGS. 5-7 and 8-11, when needle retraction tube 42 is rotated relative to body 34 as indicated by arrow 114, the forwardly projecting lug 102 pushes against the side of positioning notch 64 of body 34 and causes slide member 38 to slide relative to body 34 in the direction indicated by arrow 118. As slide member 38 moves laterally relative to body 34, fluid seal 68 (FIG. 4) disengages from head 74 of needle holder 70, eventually reaching the position shown in FIGS. 5-7 and 11 wherein the central longitudinal axis through needle retraction tube 42 is

aligned with needle holder 70. Because the diameter of front opening 98 of retraction tube 42 (FIG. 4) is slightly larger than the outside diameter of head 74 of needle holder 70, the force of expanding spring 76 (FIG. 4) propels needle holder 70 and needle 78 rearwardly into needle retraction tube 42.

[0023] Those of ordinary skill in the art will also appreciate upon reading this specification and the description of preferred embodiments disclosed here that modifications and alterations to the apparatus and method of use can be made within the scope of the invention and it is intended that the scope of the invention be limited only by the broadest interpretation of the appended claims to which the inventors are legally entitled.

[0024] Claims:

1. A needle retraction apparatus comprising a body having a forwardly projecting needle, a needle retraction mechanism seated inside the body and biasing the needle rearwardly relative to the body, a slide member attached to the body and having an opening communicating with a needle retraction cavity projecting away from the body, and an actuator rotatable relative to the slide member to reposition the slide member from a first position preventing needle retraction to a second position permitting needle retraction.

2. The needle retraction apparatus of claim 1 wherein the body further comprises a forwardly projecting luer tip.

3. The needle retraction apparatus of claim 2 in combination with an IV catheter comprising a hub that is releasably attached to the luer tip and a flexible cannula attached to the hub through which the needle projects forwardly of the hub.

4. The needle retraction apparatus of claim 1 wherein the needle retraction mechanism comprises a needle holder seated inside the body.

5. The needle retraction apparatus of claim 4 wherein the needle is attached to the needle holder and is biased rearwardly by a compressed needle retraction spring contacting the needle holder.

6. The needle retraction apparatus of claim 1 where the slide member is disposed in transverse slidable engagement with a longitudinal axis through body.

7. The needle retraction apparatus of claim 1 wherein the slide member is retained in close disposition to the body by spaced-apart tracks connected to the body.

8. The needle retraction apparatus of claim 4 wherein the slide member comprises two laterally spaced openings, each opening being coaxially alignable with the needle holder at different times by repositioning the slide member relative to the body.

9. The needle retraction apparatus of claim 1 wherein a first opening in the slide member communicates with a flash chamber.

10. The needle retraction apparatus of claim 9 wherein a second opening in the slide member communicates with the needle retraction cavity.

11. The needle retraction apparatus of claim 1 wherein the needle retraction cavity is disposed inside a needle retraction tube that projects away from the body.

12. The needle retraction apparatus of claim 11 wherein the needle retraction tube has an elongate portion with a closed end that is receivable through the second opening.

13. The needle retraction apparatus of claim 11 wherein the needle retraction tube has an open end with a radially projecting annular flange that has a diameter larger than the second opening and is supported in a forwardly facing recess in the slide member.

14. The needle retraction apparatus of claim 1 wherein the actuator is a needle retraction tube.

15. The needle retraction apparatus of claim 14 wherein the retraction tube comprises a projecting lug that engages a positioning notch in the body.

16. The needle retraction apparatus of claim 15 wherein rotation of the needle retraction tube repositions the slide member relative to the body.

17. The needle retraction apparatus of claim 9 wherein the flash chamber has a closed end disposed opposite the first opening in the slide member.

18. The needle retraction apparatus of claim 17 wherein the closed end comprises an elastomeric plug.

19. The needle retraction apparatus of claim 18 wherein the elastomeric plug can be penetrated by a cannula to establish a fluid path through the closed end of the flash chamber.

20. An IV catheter introducer comprising the needle retraction apparatus of claim 1.

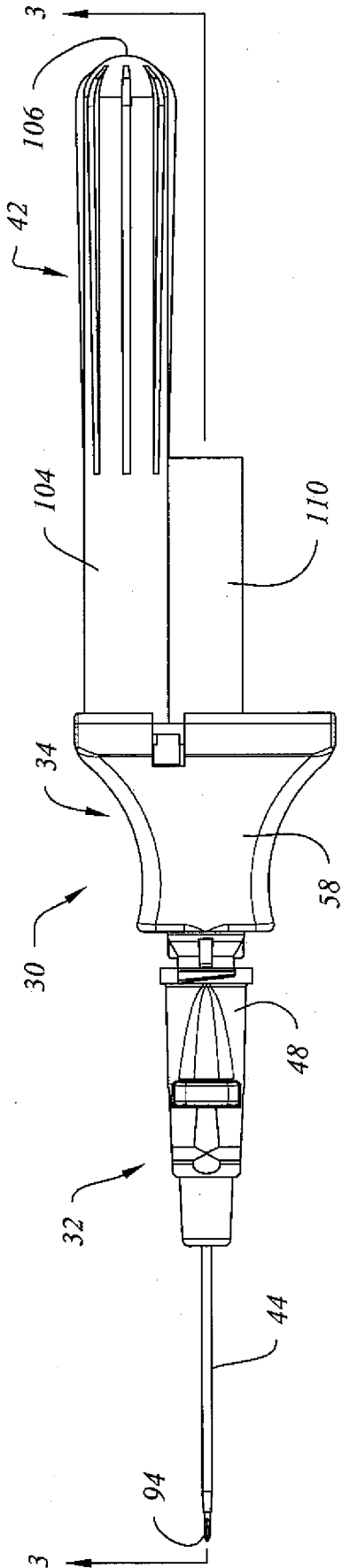

FIG. 1

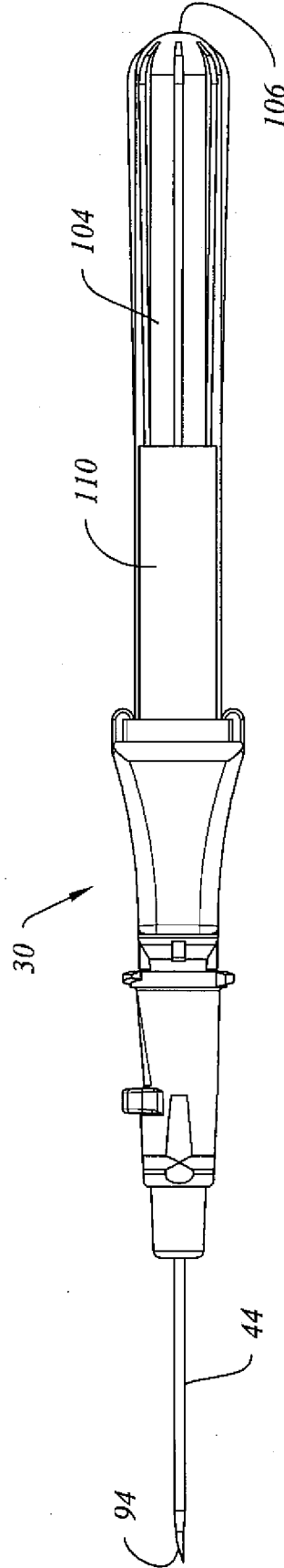

FIG. 2

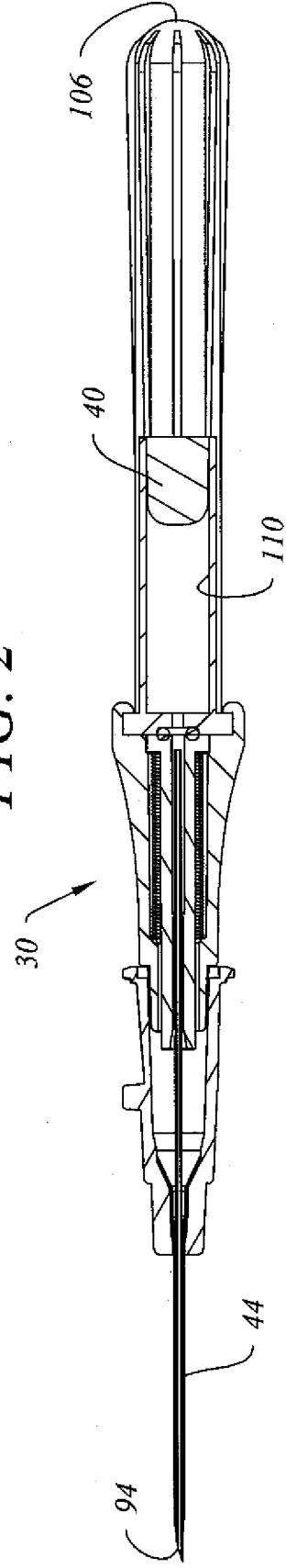

FIG. 3

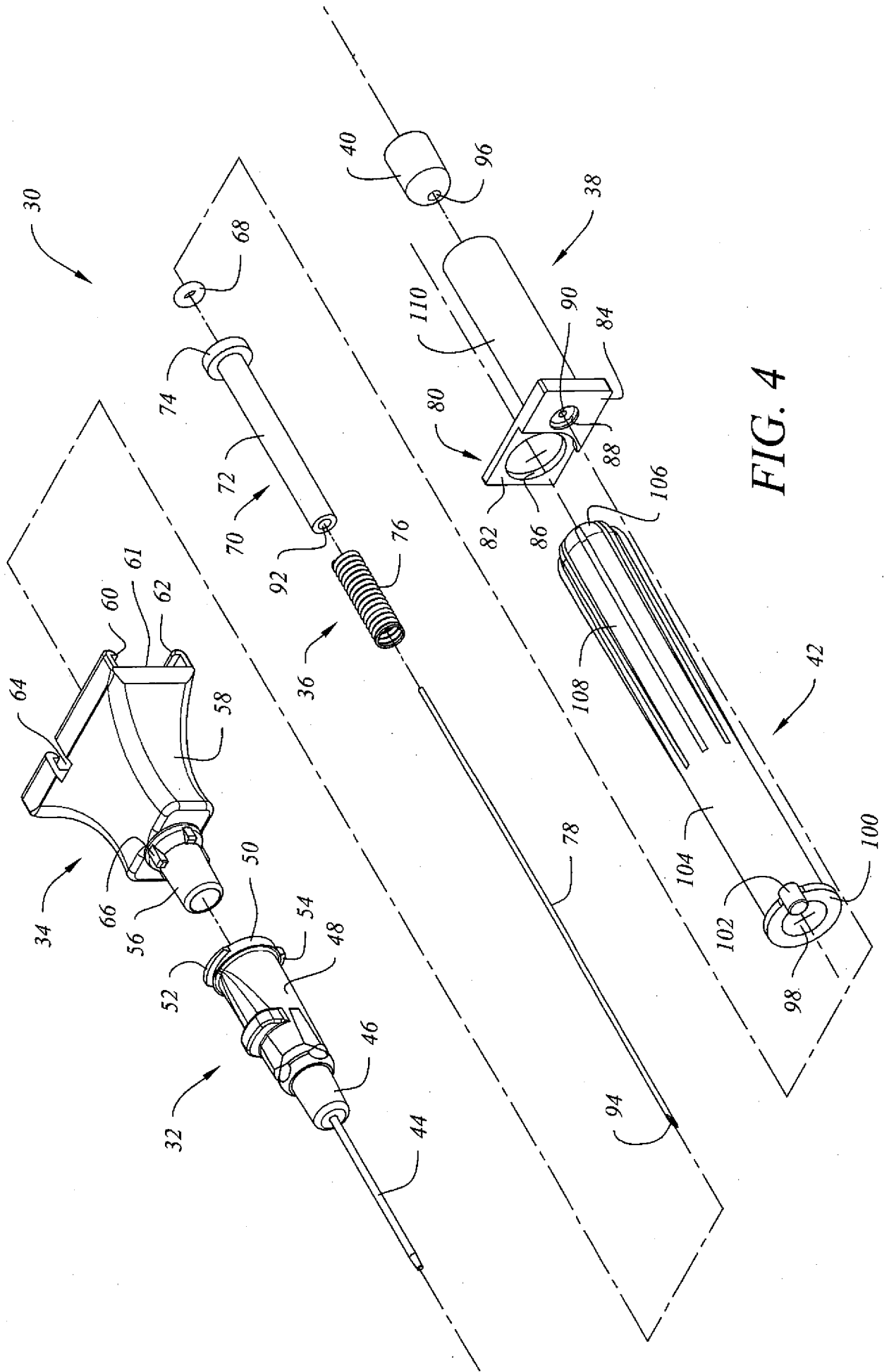

FIG. 4

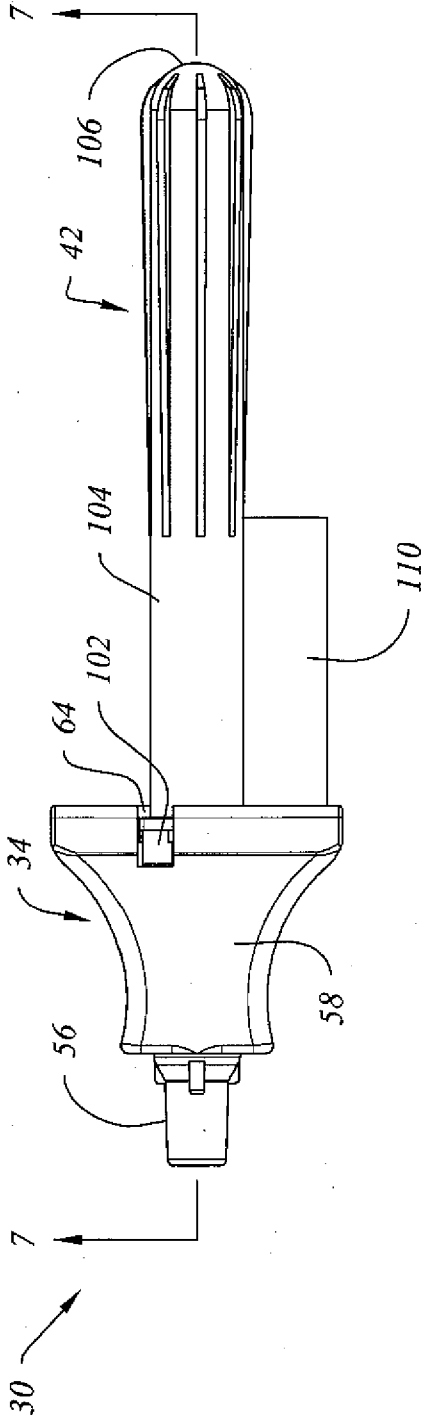

FIG. 5

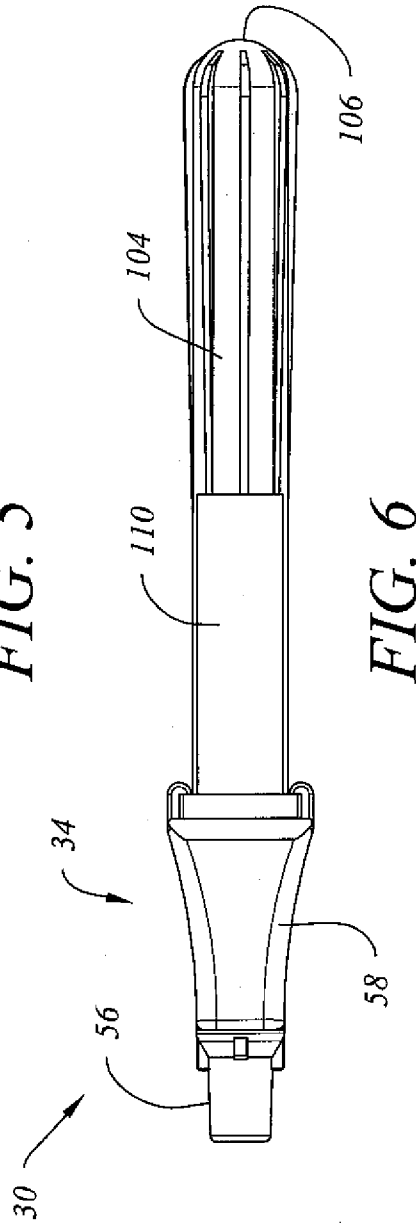

FIG. 6

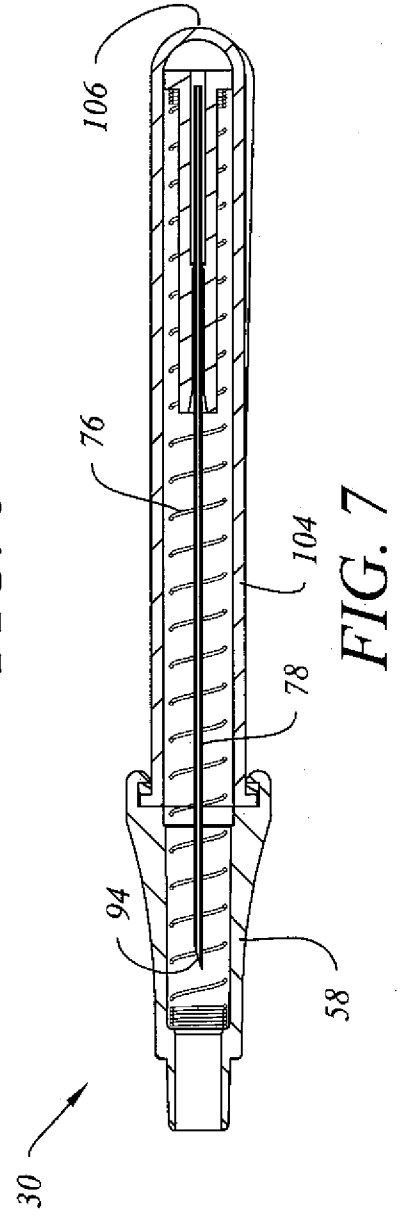

FIG. 7

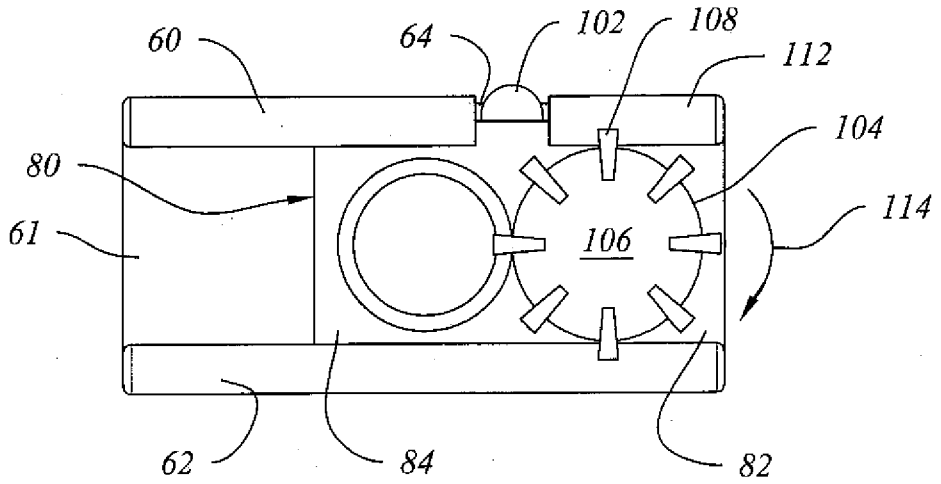

FIG. 8

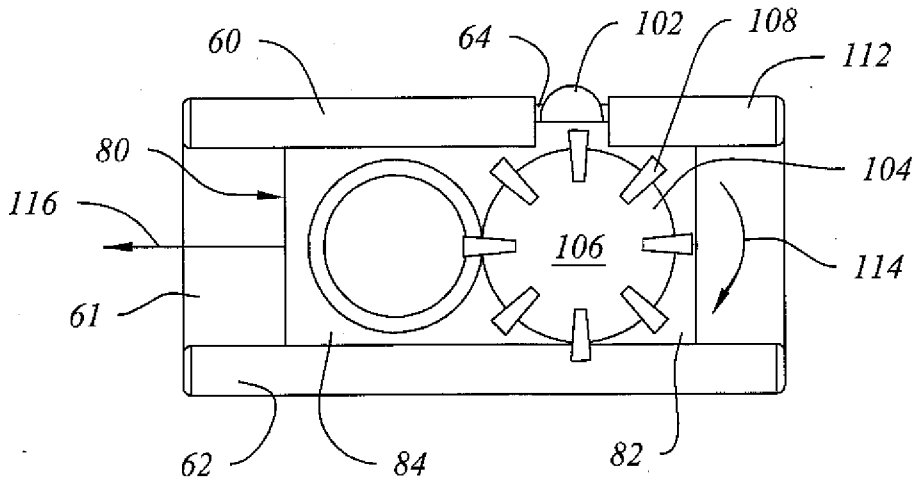

FIG. 9

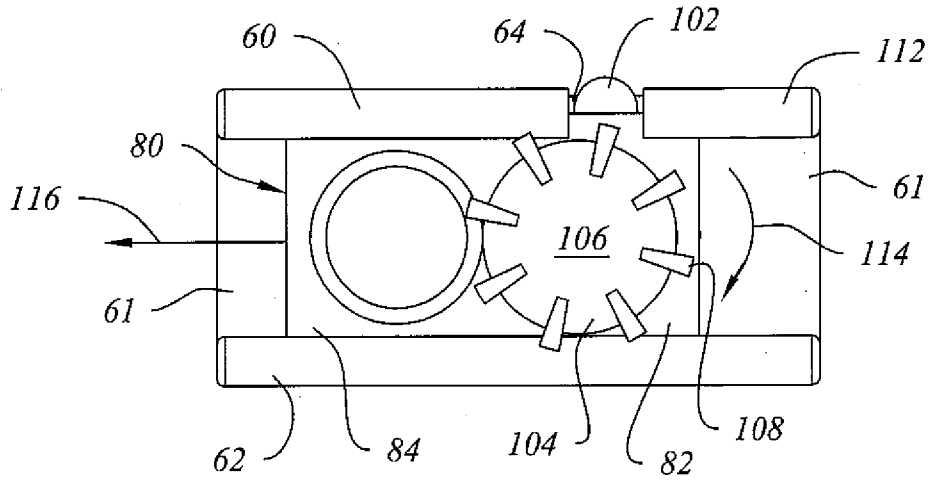

FIG. 10

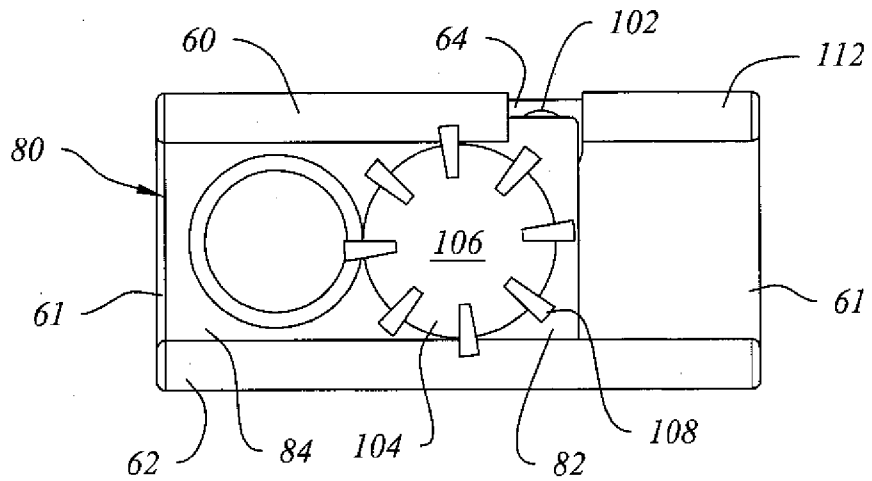

FIG. 11

INTERNATIONAL SEARCH REPORT

International application No.

PCT/US2013/072222

A. CLASSIFICATION OF SUBJECT MATTER
 IPC(8) - A61M 5/32 (2014.01)
 USPC - 604/110
 According to International Patent Classification (IPC) or to both national classification and IPC

B. FIELDS SEARCHED

Minimum documentation searched (classification system followed by classification symbols)
 IPC(8) - A61M 5/32, 5/50, 5/178, 25/00, 25/06 (2014.01)
 USPC - 128/763; 604/110, 164, 164.08, 195, 198, 263, 576

Documentation searched other than minimum documentation to the extent that such documents are included in the fields searched
 CPC - A61M 5/3232, 25/0606, 25/0631 (2014.01)

Electronic data base consulted during the international search (name of data base and, where practicable, search terms used)
 PatBase, Google Patents, Google

C. DOCUMENTS CONSIDERED TO BE RELEVANT

Category*	Citation of document, with indication, where appropriate, of the relevant passages	Relevant to claim No.
Y	US 2010/0317999 A1 (SHAW et al) 16 December 2010 (16.12.2010) entire document	1-5, 9, 11, 12, 14-20
Y	US 5,573,510 A (ISAACSON) 12 November 1996 (12.11.1996) entire document	1-5, 9, 11, 12, 14-20
Y	US 2008/0132854 A1(SHARP) 05 June 2008 (05.06.2008) entire document	2, 3
Y	US 2012/0316466 A1 (CRAWFORD et al) 13 December 2012 (13.12.2012) entire document	18, 19
Y	US 8,292,852 B2 (MULHOLLAND et al) 23 October 2012 (23.10.2012) entire document	20

Further documents are listed in the continuation of Box C.

- * Special categories of cited documents:
- "A" document defining the general state of the art which is not considered to be of particular relevance
 - "E" earlier application or patent but published on or after the international filing date
 - "L" document which may throw doubts on priority claim(s) or which is cited to establish the publication date of another citation or other special reason (as specified)
 - "O" document referring to an oral disclosure, use, exhibition or other means
 - "P" document published prior to the international filing date but later than the priority date claimed
 - "T" later document published after the international filing date or priority date and not in conflict with the application but cited to understand the principle or theory underlying the invention
 - "X" document of particular relevance; the claimed invention cannot be considered novel or cannot be considered to involve an inventive step when the document is taken alone
 - "Y" document of particular relevance; the claimed invention cannot be considered to involve an inventive step when the document is combined with one or more other such documents, such combination being obvious to a person skilled in the art
 - "&" document member of the same patent family

Date of the actual completion of the international search 04 February 2014	Date of mailing of the international search report 20 FEB 2014
---	--

Name and mailing address of the ISA/US Mail Stop PCT, Attn: ISA/US, Commissioner for Patents P.O. Box 1450, Alexandria, Virginia 22313-1450 Facsimile No. 571-273-3201	Authorized officer: Blaine R. Copenheaver PCT Helpdesk: 571-272-4300 PCT OSP: 571-272-7774
---	---