

(19) World Intellectual Property Organization
International Bureau



(43) International Publication Date
4 November 2010 (04.11.2010)

PCT

(10) International Publication Number
WO 2010/126557 A1

- (51) International Patent Classification:
H04L 12/28 (2006.01)
- (21) International Application Number:
PCT/US2009/068776
- (22) International Filing Date:
18 December 2009 (18.12.2009)
- (25) Filing Language: English
- (26) Publication Language: English
- (30) Priority Data:
61/173,459 28 April 2009 (28.04.2009) US
12/637,685 14 December 2009 (14.12.2009) US
- (71) Applicant (for all designated States except US): **WHP WORKFLOW SOLUTIONS, LLC** [US/US]; 6543A Fain Street, North Charleston, SC 29406 (US).
- (72) Inventor; and
- (75) Inventor/Applicant (for US only): **GUZIK, Thomas** [CA/US]; 5125 Juantita Ave., Edina, MN 55424 (US).
- (74) Agents: **PECK, Robert, C.** et al.; Lee & Hayes, PLLC, 601 W. Riverside Ave, Suite 1400, Spokane, WA 99201 (US).

- (81) Designated States (unless otherwise indicated, for every kind of national protection available): AE, AG, AL, AM, AO, AT, AU, AZ, BA, BB, BG, BH, BR, BW, BY, BZ, CA, CH, CL, CN, CO, CR, CU, CZ, DE, DK, DM, DO, DZ, EC, EE, EG, ES, FI, GB, GD, GE, GH, GM, GT, HN, HR, HU, ID, IL, IN, IS, JP, KE, KG, KM, KN, KP, KR, KZ, LA, LC, LK, LR, LS, LT, LU, LY, MA, MD, ME, MG, MK, MN, MW, MX, MY, MZ, NA, NG, NI, NO, NZ, OM, PE, PG, PH, PL, PT, RO, RS, RU, SC, SD, SE, SG, SK, SL, SM, ST, SV, SY, TJ, TM, TN, TR, TT, TZ, UA, UG, US, UZ, VC, VN, ZA, ZM, ZW.
- (84) Designated States (unless otherwise indicated, for every kind of regional protection available): ARIPO (BW, GH, GM, KE, LS, MW, MZ, NA, SD, SL, SZ, TZ, UG, ZM, ZW), Eurasian (AM, AZ, BY, KG, KZ, MD, RU, TJ, TM), European (AT, BE, BG, CH, CY, CZ, DE, DK, EE, ES, FI, FR, GB, GR, HR, HU, IE, IS, IT, LT, LU, LV, MC, MK, MT, NL, NO, PL, PT, RO, SE, SI, SK, SM, TR), OAPI (BF, BJ, CF, CG, CI, CM, GA, GN, GQ, GW, ML, MR, NE, SN, TD, TG).

Published:
— with international search report (Art. 21(3))

(54) Title: CORRELATED MEDIA FOR DISTRIBUTED SOURCES

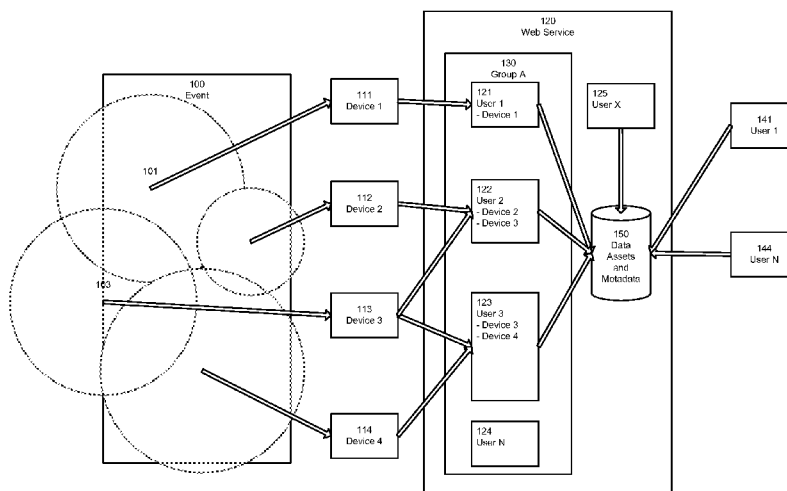

Figure 1

(57) Abstract: A method and a system of associating correlating metadata with data assets, such as video and audio files, so that the files are rendered as a combination presentation are described herein. The system includes a client a media capture device that provides on board storage, network connectivity, preprocessing, preview buffering, file management, and an eventing system. The method includes capturing the media, associating the media with other media via an identifier, and supports associating correlating metadata prior to time of media capture and during media capture on the capture device itself, and after media capture either on a local machine or on an on-line group. When the combination presentation is presented, additional associated advertising and annotations may be provided upon rendering.

WO 2010/126557 A1

CORRELATED MEDIA FOR DISTRIBUTED SOURCES

[0001] This patent claims priority to U.S. provisional patent application serial number 61/173,459 filed on April 28, 2009 and U.S. non provisional
5 patent application 12/637,685 filed on December 14, 2009, which applications are hereby incorporated by reference.

TECHNICAL FIELD OF THE SUBJECT MATTER

[0002] This subject matter of the present application relates to aggregating and correlating distributed media.

10 BACKGROUND OF THE SUBJECT MATTER

Media data comes in many forms including, but not limited to, video, audio, still images, and text. Presently, media data is captured, that is recorded, and stored on a storage media that is dependent on the form of media data. For example, video is captured by video cameras, audio is captured via
15 microphone and recorders, and still images are captured by cameras.

[0003] Currently, video cameras and digital recorders are used for a wide range of applications. While the use of video cameras and digital recorders is typically associated with personal events. There are many applications of the use such devices for commercial purposes including
20 security and surveillance. For example, police car video cameras are used to record stop encounters.

[0004] As described above, more than one form of media may be used to capture an event. For example, a security camera and a digital audio recorder may capture both video and audio data respectively from a crime
25 scene. Afterwards, a police officer or security supervisor may add text

captions to the video using computer-based software or on-camera functions. Combining different forms of media for presentation is termed multimedia, and accordingly there may be multimedia capture of security events and crime scenes.

5 [0005] Presently, captured media is most commonly stored as digital data, thereby becoming a data asset. Digital data assets may be streamed to users or consuming devices in real time, or may be captured and later transported as a file for streaming.

[0006] The consumer electronics revolution has made digital video
10 cameras, digital still cameras, and digital recorders ubiquitous. Accordingly, commoditized video cameras and digital recorders have become available for security applications. Digitization and miniaturization has led to the production of video cameras that can fit in a mobile phone with ever improving resolution. Further, the advent of commoditized compact memory has
15 enabled large amounts of video data to be stored in such devices, in a cost effective manner. As of this writing, 16 gigabytes (GB) of storage space can store 40 hours of video data with average resolution. Accordingly, large amounts of digital data assets may be captured from many different sources and in many different media. Furthermore, the individuals that capture a
20 security event or crime scene with a camera or recorder need not necessarily be related. For example, at a crime scene, there may be surveillance cameras that were stationed in the area long before the scene; there may be police officers with mobile cameras and recorders, and another police officer taking still shots with a digital camera.

[0007] With the Internet, digital data assets may be shared in both in edited and non-edited form. In the past, files were shared simply by transferring peer-to-peer, such as e-mailing files or uploading to a LAN based server. Later, digital data assets were posted and distributed via web pages
5 via internet protocols. Currently police officers and security personnel can post and distribute digital data assets to a centralized location via web services, with facilities to search and tag on posted assets. In this way, different recordings of the same crime scene might be aggregated to help solve a crime case, regardless of who originally captured or uploaded the
10 digital asset.

[0008] In general, there is presently a critical mass of digital data assets that can be correlated and combined together. For example, panoramic software can stitch together different still photos taken at the same time of the same event and result into a single photo. Different video and
15 audio feeds may be mixed together to make a composite rendering. However, such efforts are typically manual in nature and use relatively short media clips.

[0009] At present, automating the correlation and combination of multimedia of relatively large long data assets, such as those hundreds or
20 thousands of hours in length is not done. Moreover, recording metadata to aid in correlating the data assets with other data assets is not presently done. Finally, using such correlating metadata to automate correlations of data assets into a combination presentation is not presently done.

SUMMARY OF THE SUBJECT MATTER

[0010] The embodiments described herein relate to a comprehensive system to store data assets, associate correlating metadata, share data assets in either a peer to peer manner or via a web service or equivalent, 5 retrieve data assets, and present data assets either singularly or in various combinations.

[0011] Method embodiments described herein may include associating an identifier along with correlating metadata such as date/timestamp and 10 location. The identifier may then used to associate data assets that are related to a particular incident. The identifier may be used as a group identifier on a web service or equivalent to promote sharing of related data assets. Additional metadata may be provided along with commentary and annotations. The data assets may be further edited and post processed. The 15 data assets may be then presented either singularly or in various combinations, either locally or in a custom application. A custom application may be hosted at a network operation center as well with capabilities of directing collection of data assets.

[0012] System embodiments described herein may include a mobile 20 client that is based on a modified cell phone. The mobile client may include video cameras and other media recording capabilities, location service functionality such as global positioning system (GPS) functionality, and full networking capabilities. The mobile client may also support a preview mode by which the video camera captures not only an incident at the time of 25 recording starting, but also several seconds of video preceding the event as

stored in a preview buffer. The mobile client may further include a custom charger in the form of inductance coils and a file manager that provides file system capabilities specific to a mobile device. Even further, the mobile client may include a tamper proof chassis and optional features for physical secure
5 storage.

[0013] The mobile client hardware may be exposed to application software via an eventing system that allows programmers to add event handlers for custom software events. The system as disclosed may also include end to end applications covering use of external advertising and
10 annotations and tools.

BRIEF DESCRIPTION OF THE DRAWINGS

[0014] Non-limiting and non-exhaustive examples are described with reference to the following figures. In the figures, the left-most digit(s) of a
15 reference number identifies the Fig. in which the reference number first appears. The use of the same reference numbers in different figures indicates similar or identical items or features.

[0015] Fig. 1 is a diagrammatic illustration showing individual actors, hardware, and software in a web service embodiment of correlating media for
20 distributed services.

[0016] Fig. 2 is a diagrammatic illustration showing individual actors, hardware, and software for sharing and correlating data assets in accordance with a web service embodiment of correlating media for distributed services.

[0017] Fig. 3 is a diagrammatic illustration showing individual actors, hardware, and software for capturing an event, sharing data assets, and correlating the data assets into a final result. In a peer-to-peer embodiment of correlating media for distributed services.

5 **[0018]** Fig. 4 is a flowchart of an exemplary method for correlating media for distributed services.

[0019] Fig. 5 is a diagrammatic illustration showing key components of hardware for an exemplary mobile client in accordance with various embodiments for correlating media for distributed services.

10 **[0020]** Fig. 6 is a diagrammatic illustration of correlating media for distributed services in a cloud computing environment.

[0021] Fig. 7 is a diagrammatic illustration showing key components of software for an exemplary mobile client in accordance with various embodiments for correlating media for distributed services.

15 **[0022]** Figs. 8A and 8B are diagrammatic illustrations of exemplary non-client software applications in accordance with various embodiments for correlating media for distributed services.

[0023] Fig. 9 is a diagrammatic illustration of the individual actors, hardware, and software applied to a personal use scenario of correlating
20 media for distributed services.

[0024] Fig. 10 is a diagrammatic illustration of the individual actors, hardware, and software applied to a law enforcement scenario of correlating media for distributed services.

DETAILED DESCRIPTION OF THE PREFERRED EMBODIMENT

Combining and Correlating Digital Data Assets

[0025] The embodiments described herein pertain to methods,
5 systems, and apparatuses for capturing digital media as data assets,
associating correlating metadata with those assets, and retrieving and
correlating data assets at least partially based on the correlating metadata. In
this way, the task of correlating disparate data assets into a coherent
combination may be automated.

10 **[0026]** There are many different types of combinations of data assets.
Such combinations may be of similar media, as in making a panoramic
composite photo by stitching together different digital photos. Further, such
combinations may be of different media, such as adding a custom audio track
to a video. Such combinations may even be of the same context, such as
15 providing different views of the same police, fire and/or security incident. In
extreme situations, different contexts may be combined such as with a
mashup. Such combinations need not be composites and may be presented
as various different correlated media assets displayed side by side, or as
combined into an integrated whole.

20 **[0027]** To support automating such a varied range of combination
presentations, the embodiments described herein allow a rich range of
correlating metadata to be associated with a data asset. When two or more
data assets are to be combined, as a composite or otherwise, the metadata
may provide a referent by which each data asset may be correlated.

Common metadata may includes, but is not limited to, date/time stamp and location metadata.

[0028] For example, a video clip may have date/time information stored for each frame, and an audio clip may have date/time information stored for each track segment. The video clip and the audio clip may be combined into a multimedia presentation by correlating the date/time stamps of the two files. In this case the correlation is a synchronizing of the two files and the presentation is a composite of the two files. Of course, the number of such files that may be so combined is not limited to just two.

[0029] Correlation can be based on multiple metadata values. For example, multiple still photos might be stored not only with date/time stamp metadata, but also with location metadata, possibly from a global positioning satellite (GPS) stamp. A software tool that collects all stored still photos taken within a window of time, for example during a security or police response to a crime incident, and close to the scene of a crime, may combine the photos of the incident into a sequence of pictures with which for investigation purposes. Here the correlation is both by time and location, and the presentation is a non-composite simultaneous display of different data assets.

[0030] Correlating metadata can be based on a set of custom fields. For example, a set of video clips may be tagged with an incident name. Consider three field police officers each in a different city and in a different time zone, recording videos and taking pictures at exactly at midnight on New Year's Day 2013. Each officer might tag their videos and their still photos with "New Year's Day 2013 Security Watch". A software tool may collect all stored videos with that tag, and may further provide a presentation rotating between

the videos and photos for the event. Here the correlation is made using a custom tag, is not specific either to time or location, and is a non-composite display of different data assets.

[0031] This degree of flexibility means that correlations can be both by absolute referent and by relative referent. Most incidents occur at an absolute time and location, and incidents may occur at different locations (such as a bank robbery occurring at a bank, and a breaking and entering at a power main to shut off the power to enable the robbery). Another example would be the security of an event over multiple locations such as the election or Olympics which are held at different venues in a city or different cities. In other situations, incidents, such as a high speed chase may span multiple counties. The above is a correlating example of synchronizing video and audio by means of a relative referent, whereby the time stamp need not be of absolute time, but could potentially be synchronized to the beginning of the data clips.

15 The above example of the New Year's Day event is an extreme example of correlating by a relative referent. The "New Year's Day 2013 Security" tag is arbitrary, and correlates data assets without regard to traditionally absolute referents of date/time and location. This example is also known as date/time shifting and location shifting.

20 Exemplary Platform for Correlating and Combining Data Assets

[0032] Figs. 1 and 2 illustrate an exemplary platform for correlating and combining data. Fig. 1 illustrates capture of data. Fig. 2 illustrates presentation of data.

[0033] In this exemplary platform, event 100 is to be captured by recording devices 111-114 each of which is to capture some part of event 100 as represented by scopes 101-104, respectively. The data captured by the respective scopes 101-104 may be uploaded in the form of files to a web service 120 by users with accounts 121-123 that can transfer files from their respective devices 111-114. The web service 120 groups users into groups, e.g., users with accounts 121-124 belong to group 130. Note that device 113 can be associated with multiple user accounts 122 and 123. Note that the user with account 124 does not have a device but can still participate in a group. The users thus organized can store the data assets into a central storage 150. The user with account 125 which does not belong to group 130 may potentially belong to any number of other groups on the web service, or alternatively may join group 130. The user with account 125 may have devices (not shown) and upload to the central storage 150. Users 141 and 144, with accounts 121 and 124 respectively, may log on later to tag, comment, annotate, or otherwise associate metadata with the uploaded files. The following discussion describes this configuration in more detail.

[0034] Event 100 may represent the capture of any set of media data. Usually an event consists of a discrete real-world event such as a crime incident. However, some users may wish to combine different events in different locales and time zones. These different events may not even have any context in common, save for a user's preferences. For example, a police supervisor may be looking for patterns of assaults in a jurisdiction. Each individual assault was perpetrated independently, but studying the aggregate data, the police supervisor may detect areas of high risk.

[0035] An event can be captured by one of many commonly available devices 111-114. Exemplary devices include, but are not limited, to video cameras, digital audio recorders, or digital still cameras. Another example of a recording device might be a laptop that stores GPS samples or other location service samples to track location. Devices 111-114 may record data in analog format but then convert the data to digital format later for sharing. Devices 111-114 may further have the capability of capturing different types of media at the same time. For example, a video recorder usually captures video and audio at the same time. Alternatively, many digital cameras support both video and still modes of capture. Notwithstanding the many features of present day devices, usually a single device at best can only capture a subset of an event as represented by scopes 101-104. Each scope only covers a subset, but a combination of the scopes may provide a more complete capture of the event.

[0036] Devices 111-114 may generally store captured media either as files or stream the captured media to a remote device that will persist the data. Eventually the captured media may be stored as a digital data asset, usually as a file. In the alternative, data may be persisted on analog tape.

[0037] Devices 111-114 may have the ability to associate metadata either before capture or at time of capture. For example the respective devices may provide for a user to provide a default tag for all files such as camera identifier (ID). During capture, the respective devices may store data/time stamp information or location service tracking location data such as GPS with the file.

[0038] An example of a default tag associated before time of capture is an Event ID (also called a Pounce™ ID) that may be used to indicate which files are candidates for correlating for an event. Generally an Event ID corresponds to a unique event. The end to end process is discussed in the context of Fig. 4. Metadata association is discussed in more detail below in the context of Fig. 5.

[0039] In the exemplary platform in Fig. 1, each device 111-114 belongs to at least one user (not shown), and each user has an account 121-123. In the case where data is being shared peer to peer, accounts may not be necessary since devices 111-114 may access each other without the need for intermediate storage and because the user is operating only one device. However, in the Fig. 1 exemplary platform, note that the user associated with account 123 is operating both devices 113 and 114. Further note that devices 111-114 need not have been operated at the same time. For example, a user might record video in a police car on a device for an incident and on a separate device record video and/or audio that may or may not begin or end at the same time.

[0040] Accounts 121- 124 may be aggregated on web service as 120 as a group 130. As a default, a group may be identified to include all users with data files with the same Event ID. A group may also be either a predefined or a self selecting group, for example a set belonging to a security agency, or a set of all police officers belonging to the homicide division, or even a set of officers seeking to share data regardless if they bellowing to an organized or unorganized group. A group may also be related to some other grouping external from the web service, e.g., a law enforcement Case ID

seeking all data assets that might have captured an event such as a crime in progress.

[0041] In this exemplary platform, users with accounts associated with devices 111-114 then may upload files to central storage 150. Users may
5 belong to zero, one, or more groups. An example of where a user belongs to zero groups is includes a user having initially established an account, although an alternative embodiment may include a user creating a default group. An example of a user belonging to multiple groups includes a video file belonging both to a group to capture a security event and to a group
10 showing what other security personnel were doing on a given day.

[0042] Users with accounts in a group may also have the ability to add metadata after capture of the media data. As illustrated by users 141 and 144, adding metadata may include, but is not limited to, commenting on files by manually adding meta data or by automation, such as tagging, which may
15 be performed via software tools and by scripting.

[0043] Users with accounts are not limited to associating data assets with metadata. Users with accounts in a group also have the ability to edit the data assets directly. For example, a still photo may be uploaded and later cropped using a digital photo editor. The editor may be provided as on-line
20 tool as part of the web service or, alternatively, may be provided as desktop software by which the user may download the file, edit, and re-upload the edited file.

[0044] User account 124 pertains to a user who is not associated with a device. In general, user accounts may be associated with zero, one, or more

devices. Because users can add metadata after capture, a user may still participate in a group without being responsible for providing data assets to the group. This is a common scenario for master editors as well as mixers who use data assets as samples.

5 [0045] In this exemplary platform embodiment, the result is a central store 150 of data assets that have been associated with correlating metadata from before, during, and after time of capture. At least some subset of the metadata may be used for correlation.

[0046] Fig. 2 includes references to features first introduced with
10 reference to Fig. 1 to continue discussion of this exemplary platform embodiment. Central store 150 may be accessed by external users for metadata inclusion and final presentation. An external user 144 may access correlation and presentation tool 220 that translates user 144's operation into a query performed by search module 210. At least some of the query criteria
15 may be based on correlating metadata. The search module 210 may retrieve data assets, from central store 150, that match the criteria of the query. Additionally the search module 210 may retrieve external data sources. The search module 210 may forward query criteria to an external correlation module 260, which retrieves data assets from an external data store 230 and
20 associates the necessary correlation metadata with the data assets. Examples of external data include, but are not limited to, map data and to advertising data. External data may be retrieved by the search module 210 along with data assets from central store 150. The search module 210 may then return the combined data to the correlation and presentation tool 220.
25 Accordingly, additional correlations may be made, others correlations

removed, and the data assets may be presented side by side, in rotation, or potentially in composite form to user 144. A final presentation may be saved as a single file or single distribution, and persisted on data store 240 where it may then be viewed by other users 250, regardless of affiliation with a group
5 or from the web service. The following discussion describes this process in more detail.

[0047] The correlation and presentation tool 220 is represented as a single entity. However, correlation and presentation may be implemented in different modules, for example as different dynamic link libraries (DLLs) within
10 a single application or as separate plug-ins from a browser. The correlation and presentation tool 220 may have a query tool (not shown) that provides for simple queries, e.g. retrieve all data assets relating to “New Year’s Day 2013 Security Watch.” Alternatively, the tool may provide the back end infrastructure for a domain specific application such as a law enforcement
15 dispatch tool. Several such applications, including applications for law enforcement and for transportation are discussed below.

[0048] The correlation and presentation tool 220 may invoke search module 210 in the form of a query. The query may be a SQL query that retrieves data assets according to a series of where clauses. For example in
20 the following SQL pseudo-code:

```
select data_asset_id  
from data_asset_table, group_table  
where data_asset_table.group_id = group_table.group_id  
and group_id = [group_id]  
25 and data_asset_table.date_time_stamp = [date_time_stamp]
```

the correlation and presentation tool 220 may retrieve all data asset identifiers in a specified group at a particular time. In the alternative, the query may simply be a parameterized DLL call invocation as in, for example, the following function declaration pseudo-code:

5 ReturnDataAssetByTimeStamp([group_id], [date_time_stamp]).

[0049] In addition to filtering and correlating via predefined fields, the embodiments described herein may support filtering on custom metadata. One option to support custom metadata is to support a number of custom fields within a relational database. In this way, a simple text comparison may
10 return all data assets when a custom tag equals, e.g., "New Year's Day 2013 Security Watch." In the alternative, some relational databases may support stored procedures that can invoke binaries. For example, MICROSOFT SQL SERVER (TM) allows invocation of COM object and ORACLE 10G (TM) allows invocation of JAVA (TM) objects.

15 **[0050]** In the above examples, the actual binary to execute the queries is the search module 210. The search module may not only invoke data assets in the central store 150, but also zero, one, or more external databases 230 via the external correlation module 260. Example external databases may store, as examples only, mapping data, advertising data assets, domain
20 data such as public Securities and Exchange Commission (SEC) filing data, or integration with other applications such as law enforcement case management databases. At this stage, correlations may occur in the form of join statements in SQL, or binary equivalents.

[0051] The external correlation module 260 may be responsible for
25 returning data assets from the external database 230 along with correlation

metadata. The data assets may be returned with at least an Event ID to allow general correlation with the other data assets returned from the central store 150. Any metadata that was captured before or during recording may be converted to a format correlatable with the data assets on the central store 5 150. For example, if a date-time stamp is in a different format, the external correlation module may convert the date-time stamp to the central store 150 format.

[0052] The external correlation module 260 may have access to multiple databases, so it may use one external database for data assets and 10 another database for metadata. One example is a Joint Photographic Experts Group (“JPEG”) file that has GPS information which is correlated with a geolocation advertising database that links ads specific to the JPEG’s location.

[0053] When the search module 210 retrieves data assets and 15 associated metadata, it may return the data to the correlation and presentation tool 220 optimally as a rowset. Specifically, it may return a binary enumerable set of rows in which each data row contains a data asset ID, an Event ID, related metadata and at least an accessible reference to the data asset so that the correlation and presentation tool 220 may actually 20 retrieve the data asset. In the alternative, when a high bandwidth dedicated connection is available, the data assets may be served as a binary large object (“BLOB”). In the alternative to a rowset, the search module may return the data asset id, event id, metadata, and data asset reference as an eXtensible Markup Language (“XML”) file.

[0054] Once at the correlation and presentation tool 220, the data assets may be further correlated for presentation. For example, once the data assets are local to the correlation and presentation tool 220, further filtering may be performed resulting in changing correlations. For example, when the
5 rowset returns all data assets focusing on a particular crime incident, it may be possible to retrieve only the data assets focusing only on a particular person under surveillance. Because of the extent of possibilities, correlations may be driven by a custom rules engine.

[0055] The correlation and presentation tool 220 may further support
10 displaying the data assets both simultaneously and as composite. One example of such displaying would be to have multiple synchronized videos of a security incident playing on small screens and providing a control to view images from a selected one of the small screens on a large screen. Another example would be to stitch together individual still images into a single
15 composite. Yet another example would be to display a first video followed immediately by a second correlated video.

[0056] Composite presentations may require editing capabilities on the subject data assets. For example in stitching, the different JPEGs taken from different cameras and different locations will vary in shading, color filtering,
20 and the like. Software post processing modules may be resident in the correlation and presentation tool 220 to apply digital photo processing to correct and homogenize the JPEGs to be stitched.

[0057] As a result of the correlation and presentation functions being integrated into the same tool 220, the correlation engine itself may be used to
25 determine which data assets are to be post processed. For example, the

correlation function may identify which JPEGs have an average darkness beyond a predetermined threshold. In the alternative, the correlation engine might calculate an average darkness and homogenize the images to that average.

5 [0058] After post processing, the correlation and presentation tool 220 may be used to present the final presentation to the user 144. The user may apply other processing as desired.

[0059] The user 144 has the option of storing the final presentation as a single multimedia file or, in the alternative, as a single distribution of multiple
10 files. The single file or distribution may be stored on an intermediate data store 240 where other users 250 may view or access.

[0060] The intermediate data store 240 may be a networked share drive or a file server accessible via the web. In the alternative, it may be portable media such as a memory stick or DVD-ROM. Access to the data on
15 the intermediate data store 240 may be encrypted or password protected.

[0061] In this exemplary platform embodiment, the result is a single multimedia file or single distribution that combines multiple data assets that have been correlated for consumption by a user.

Exemplary Peer to Peer Embodiment

20 [0062] Fig. 3 illustrates a peer to peer embodiment, whereas Figs. 1 and 2 illustrate a web service centric embodiment.

[0063] Event 310 may be captured by mobile clients 321 and 322, both configured in accordance with the embodiments described herein. Mobile client 321 may then capture a portion of event 310 via video recording 331.

Mobile client 322 may similarly capture a portion of event 310 via video recording 332.

[0064] During the recording, both mobile clients 321 and 322 may store metadata identifying the date/timestamp and location of the recording.

5 Potentially each client may also store data assets with different date/timestamps and locations.

[0065] After the event is over, mobile client 321 and mobile client 322 may attempt to establish a peer to peer, mesh, LAN, or WLAN connection over the Infrared Data Association (“IRDA”) protocol. Specifically, if mobile
10 client 321 initiates, the mobile client may first generate an Event ID based on the mobile client’s device number. The user of the mobile client may add additional metadata, e.g., the name of the event. Mobile client 321 may then send this metadata over to mobile client 322 via IRDA. When mobile client 322 sends an acknowledgement, a link 340 may be established. Henceforth,
15 any data assets transferred over the link may be tagged with the Event ID and associated metadata.

[0066] Because this is a peer to peer collection, mobile clients 321 and 322 can enumerate each other’s data assets. Mobile client 321 may enumerate all data assets on mobile client 322 taken near the GPS location of
20 one of his video recordings taken at the event and around the times of the event. Then mobile client 321 may retrieve all those data assets. When the data assets are transferred, the data assets may be tagged with the Event ID and associated metadata. Mobile client 322 may similarly perform such an action to mobile client 321.

[0067] After data transfer, either mobile client 321 or 322 or both may opt to terminate data connection 340.

Exemplary Correlation Method

[0068] Fig. 4 illustrates an exemplary method for correlating data assets regardless of platform.

[0069] In step 410, an Event ID (also called a Pounce™ ID) may be obtained. This Event ID is provided as the minimal amount of metadata to correlate the resulting data asset with other data assets. Data assets with the same Event ID may be retrieved together. A data asset may eventually have more than one Event ID.

[0070] In step 420, correlation metadata prior to capturing the data asset may be applied. Correlation metadata may include, but is not limited to, the Event ID. Other correlation metadata may include the identity of the person capturing the data and a location stamp.

[0071] In step 430, data capture commences. During capture, correlating metadata may be captured along with the media. For example, GPS samples may track location during a mobile video recording in progress.

[0072] Once recording is complete, at decision block 440 a decision is made if the resulting data asset is to be shared in place via a peer-to-peer connection or uploaded to a web service.

[0073] If the data asset is to be uploaded to a web service, a group corresponding to the Event ID may have to be joined 450 and then uploaded to a central store 460 via the web service. Alternatively, if the data asset is to be shared in place, there is no need to upload the data.

[0074] In step 470, the data asset may be modified multiple times. In 471, additional metadata, correlating or otherwise may be applied.

[0075] In step 473, the data asset may be post-processed. For example, if the uploaded data is a still JPEG, it may be cropped. Another 5 example includes correlating the data asset with other data assets and integrating them together.

[0076] At decision block 472, a decision of whether to share the final data asset may be made.

[0077] If the final data asset is to be shared, in step 480 the data asset 10 may be stored in a memory different than central storage, such as a memory stick or a DVD-ROM, and the data asset may then be ready for distribution. Otherwise, the data asset remains in storage for further retrieval and other actions. The following discussion describes this process in more detail.

[0078] In step 410, the Event ID may be created in many different ways 15 provided that the Event ID is sufficiently unique to identify one or more sets of data assets covering at least a portion of an event. Again, while an event may correspond to an actual real world event, for purposes of the embodiments described herein, an event may be a set of recordings that are to be collected together for any reason, real-world, artistic, or otherwise. For clients enabled 20 with consumer software to create an Event ID (e.g., Pounce™ software), the Event ID may be a globally unique identifier ("GUID") generated by software such as guidgen.exe from MICROSOFT™. Alternatively, the Device ID of the capturing device may be used. On a cell phone if the transport is short message service ("SMS"), the SMS ID may be used as an Event ID. For yet

another example, for Twitter™ based distribution, the PID plus additional supporting text may be used for an Event ID.

[0079] In step 420, pre-capture metadata is to be applied to the one or more sets of data assets. The metadata may include the Event ID as well as
5 any metadata globally applicable to the one or more sets of data assets such as, but not limited to, name of the person capturing the event, date/time stamp, location, and device type. The pre-capture metadata preferentially is stored within a data asset persisted as a file. For example the MICROSOFT™ advanced systems format (“ASF”) supports the placing of
10 support metadata within the file format itself. Alternatively, the metadata may be stored separately and distributed as a companion file for the one or more sets of data assets.

[0080] In step 430, media is captures, which may include capturing an event and metadata at the same time. Examples include, but are not limited
15 to, location markers, timestamp, and telemetry. As in step 420, the metadata may be stored along with the data in the asset as a file, but could alternatively be stored separately in a companion file.

[0081] In scenarios where there are a small number of users with a small number of files, the files may be retrieved or edited in place in a peer to
20 peer network. In such situations, a web service may not be necessary, and per step 440, may bypass joining a group and participating in a web service.

[0082] However, in peer to peer connections, the larger the number of users, the more cross-connections and communication overhead is required. For N users, there are $(N * (N+1)) / 2$. Thus, for example, three users would
25 require six cross-connections and four users would require ten cross-

connections. Since the overhead to maintain connections would become prohibitive, for a large number of users, a web service may be preferable. Per step 440, a non peer-to-peer scenario may involve a web service by which a group may be joined corresponding to the Event ID and the data asset being
5 uploaded to a central storage. For example, when uploading a video file to a web-based video repository, a user may upload an associated text field which in turn may contain an Event ID. As part of the upload, the user may also upload license data (not shown). As an alternative to a web service, a service on a corporate LAN might be employed as well.

10 **[0083]** In step 470, once the data asset has been captured, a decision to modify the data asset may be made. The modification may include, but not be limited to, one or more of adding metadata, applying post-processing including combining data assets via correlation metadata, or persisting the data asset for distribution in steps 472 and 480.

15 **[0084]** In step 471, metadata is applied after the data is captured. In fact, the Event ID may be edited or changed, or an additional Event ID may even be added. Further, custom metadata may be added; or if custom fields of metadata are redefined, old metadata may be made consistent with a new format. In the case of external data assets being added, as described in
20 reference to Fig. 2, items 230 and 260, metadata may be converted to match metadata of other data assets. In step 473, data assets are post-processed. Such post-processing may include editing the data asset, e.g., cropping photos, changing color distribution; providing other special effects; or combining data assets. For example, combining and correlating an audio
25 track and a video track may be considered to be post-processing or perhaps

are just combine virtually for during the process. An example is a police video from a car in the form of a file and audio overlaid from the device that recorded audio while outside of the car.

[0085] In step 472, if the decision is to share the data asset separate
5 from the platform as disclosed, the data asset may be stored on a separate portable media such as a memory stick or DVD-ROM. Alternatively it may be stored on a network drive. The sharing may be in the form of a single file, or alternatively in a distribution of one or more data and one or several metadata files.

10 **[0086]** In this exemplary method embodiment, the result is a single multimedia file or single distribution that combines multiple data assets that have been correlated for consumption by a user.

Exemplary Hardware Platform

[0087] The platform implemented by the various embodiments
15 described herein may be based on commodity hardware. In the alternative, custom hardware may be applied to implement the platform for improved speed or efficiency. The server hardware may be based on a standard personal computer ("PC") architecture, or may be based on cloud computing as will be described later. The client may be a PC client with the ability to
20 capture media, or a custom mobile client as described in Fig. 5.

(i) Standard PC Architecture

[0088] Both servers and clients for the platform implemented by the various embodiments described herein may be based on a PC architecture. Specifically, there may be a processing unit comprised of one or more central
25 processing units ("CPUs") that each has one or more cores. There may be an

on board read only memory ("ROM"), e.g., a basic input/output system ("BIOS"), which manages boot up. For working memory, there may be random access memory ("RAM"); for storage, including virtual swap space, there may be one or more hard drives. There may further be an input/output
5 interface to support both serial and parallel operations. The input/output interface may contain support for a mouse and keyboard, or the PC may have a separate interface. All these parts may be connected on a bus to multiplex data and instruction connectivity. There may be a fast bus for CPU communications to RAM and a slow bus for input/output operations.
10 Connectivity between the two buses may be handled by a northbridge.

[0089] The input/output interface may include connectivity to a number of peripherals. Expansion cards or on-motherboard functionality may be directly connected to the bus. Further, there may be a video graphics card, which, in turn, may provide connectivity to a video monitor. If the PC is to be
15 networked, there may be a modem or network interface card ("NIC"). NICs may support a wide range of protocols. The PC may even have a cellular modem. Audio functions such as microphone and speaker support may be supported by an audio card. Interface for optical storage such as CD-ROM, DVD-ROM, and BluRay™ disks may be handled through the input/output
20 interface. Other portable storage such as memory sticks/thumb drives and legacy floppy drives may also be handled through the input/output interface.

[0090] In the case of clients, for media capture, cards supporting fast input/output such as Universal Serial Bus ("USB") 2.0 and Institute of Electrical and Electronics Engineers standard no. 1394 ("IEEE 1394"), also
25 known as "FireWire" interfaces can be supported by a PC, e.g., high

resolution microphones and video cameras. However, fast input/output can be any sort of data acquisition, including, but not limited to, location sampling, telemetry, or other streaming data feeds.

[0091] In the case of servers, large arrays of storage, such as Redundant Array of Inexpensive Disks (“RAID arrays”) are common. Multiple CPU and multiple core configurations with relatively large amounts of RAM provide support for large numbers of users.

(ii) Exemplary Mobile Client

[0092] Fig. 5 shows a client embodied in the form of a multimedia cell phone. Exemplary mobile client 500 contains functionality for cell phone communications including, but not limited to, transceiver 520 and a set of coding functions usually embodied in a chip set 530. Known computing functions such as a processor, bus, system clock, and memory, including but not limited to RAM, ROM, flash ROM and connectivity hardware such as antennae are not shown.

[0093] Mobile client 500 is powered by power functions 560. Information is entered via buttons 540, and potentially via a screen 570 if it is a touch screen. Visual output is provided through screen 570. Media can be captured through media input functions 510, including video and still cameras 511, and microphones 512. Metadata including correlating metadata may be entered via metadata collector functions 550. These functions are described in detail as follows.

[0094] Client 500 may receive a signal via the antenna (not shown), and then signal may then be sent to the receiving function of the transceiver 520. After the transceiver, there may be a function to determine what type of

signal is being received (not shown), to distinguish between background noise and actual voice input. After the signal type has been determined, the signal may be sent to codec 531 in the coding functions 530. The decoded signal may then be forwarded to filters 533 and error corrector 532, both of which
5 may improve the quality of the decoded signal. Finally, the signal may be forwarded to an appropriate rendering mechanism. For example, if the signal is a voice signal, then it may be sent to a transducer such as a speaker (not shown); if the signal is SMS or web browsing data or other software data, it may be sent to an appropriate software application and then displayed on
10 screen 570.

[0095] A signal may be then generated in response, be it through voice from a transducer such as a voice microphone (not shown), through buttons 540, or other inputs such as a stylus (not shown) or screen 570 if it supports touch screen functions. Regardless if the input is voice or software, or a
15 combination of the two, the signal is then forwarded to the appropriate codec 530 for coding, and then for transmission in the transmission function of the transceiver 520, and then to the antenna (not shown).

[0096] Client 500 has the ability to capture media. Contemporary cell phones also support on board media input 510 for video and still data via a
20 camera 511 and via a microphone 512. While these are known forms of input, further media input may be through data connections such as pod casts and other streams (not shown).

[0097] Client 500 further includes the ability to respond to triggering events. For example, a Radio Frequency ID ("RFID") reader (not shown), can
25 provide a software notification that an RFID card has been read an

acknowledged. In turn, the camera may be turned on for recording. Another example is a vehicle collision detector creating a software event to turn on recording.

[0098] In addition to capturing media and triggering events, client 500 includes metadata collection functions 550. For example, samples of location metadata may be collected by location service receiver 551. Geolocation metadata may include Global Positioning System ("GPS") metadata. However, because GPS is prone to error from GPS signals bouncing off of buildings in urban settings, geolocation metadata may alternatively be determined by triangulating signal strength or weakness from different cell towers with known locations. For relatively immobile clients, receiver 551 may collect geolocation metadata via internet protocol ("IP") address.

[0099] Another form of metadata is date/time data. Obtaining date/time metadata for client 500 may be accomplished using an onboard clock (not shown). Alternatively, date/time metadata may be obtained from a signal from a cell phone tower.

[00100] Yet another form of metadata is text, generally entered by a user pushing buttons 540. Client 500 may utilize a software application by which the user enters metadata values via the 10 key pads or via a touch screen 570. Such traditional button entry would be handled via button entry function 552.

[00101] Alternatively, custom functions for hotkeys 553 may be employed. Specifically, hotkeys may be used to enter common tags. For example, a user may enter the "#" key to indicate the use of a metadata tag key. Further, the user may enter a number, for example "2" if the number was

not already defined and text in the value for a metatag, such as "Jane." Thus, the next time the user wanted to tag a photo with the name "Jane", the user would press "#" to trigger metadata mode and then press "2," and then "Jane" would then be associated with the photo. If no photo or media file was
5 available upon triggering the hotkey, the user may be prompted to delete or edit the hotkey for different use. This would ease the otherwise cumbersome task of associating metadata with a restricted user interface.

[00102] Other metadata input/output functions, may include, but not be limited to USB and FireWire. Input/output functions on client 500 may include
10 but are not limited to: (1) providing other sources of media capture, (2) providing sources of detectors of triggering events, and (3) providing sources of metadata capture. Accordingly, in alternative to Fig. 5 where all of these functions are on board the mobile client 500, these functions could be accomplished via peripheral hardware.

15 **[00103]** Not shown are custom chips to aid in functions typically enabled via software. These include but are not limited to data compression chips and encryption algorithms.

[00104] Power functions 560 provide power to the all of client 500. Typically this is in the form of a battery 561. But a charger/AC input 562
20 typically recharges the battery or provides direct power.

[00105] An alternative form of charging may be performed using inductance coils. In situations such as law enforcement, remembering to charge a client device may not always be present in a user's mind. By implementing the charger as an inductance system including a program to
25 manage the charging. Specifically, the program may determine when the

system is being charged, how much power to convert, and when the system is to be disconnected. The on board mobile client processor (not shown) or a separate processor may alternatively be used, as may the on board mobile client RAM (not shown) or separate memory be used. The mobile client may
5 also have an inductance coil to receive energy, and then to the power functions 560 and there to the battery.

[00106] An off board charger may be configured as an inductance coil that connects to an electrical power source, and may further include a processor and memory to indicate when to charge and how much to charge
10 the client device. The off board charger may even further include an indicator having a charge status indicator in the form of colored light emitting diodes (“LEDs”) or, alternatively, an LED array.

[00107] Alternative charging configurations may include placing the mobile client’s charger 562 off of the device and elsewhere on the person of
15 the user. For example, coils may be placed in the sole of a user’s shoe, in or on the seat of the user’s pants, in the user’s belt, or in the web gear of the user. The corresponding charger may further be disposed on the gas pedal of the user’s car or even on a car seat, which could then charge the client device whenever the coils are proximate.

20 (iii) Mobile Client Chassis

[00108] In order to support vehicle mounting, the mobile client may be placed within a chassis of aluminum or other material, with an extendable arm that connects to the windshield of a car, much like a rear view mirror. The chassis may have tamperproof qualities and may include one or more security
25 locks that prevent theft or unauthorized modification of the mobile client.

[00109] The mobile client components may be divided into two portions to support a secure recorder configuration: (1) the data gathering portion, including cameras and microphones, and (2) the storage portion which contains the stored data. This latter storage portion may be secured in a hidden and hardened portion of the vehicle to prevent theft or unauthorized modification. The data gathering portion should be in public view; therefore, in order to best capture the surrounding events, the ability to conceal this portion is limited. However, if a malicious actor steals the camera, the actor steals only the device but not the data, which then may be later used for its intended purpose, or even to help determine who stole the camera. The hidden portion may also be hardened such that in the event of an accident, the data storage may be recovered or still functional to upload data.

[00110] Several alternatives may be exercised to prevent stealing the data gathering portion. One alternative is to integrally mount the data gathering portion into the vehicle's dashboard, such that removal requires removing the dashboard and unbolting the device. This alternative would lengthen the amount of time to remove the data gathering portion to greatly increase the chances that a would-be thief would be caught. For scenarios where an officer wants an option to move the camera, the camera may be removed from the vehicle when not in operation, and stored securely in a separate location. In either alternative, a would-be thief is deterred or prevented from stealing the data gathering portion.

Connectivity

[00111] Embodiments of the platform support data connectivity. Data connectivity from a PC architecture client is primarily from a network interface

card, for example an Ethernet card, or in the alternate from a dial up modem. Data connectivity from a mobile client most commonly would be via a cellular connection. Clients are not limited to just one form of connectivity, and may have multiple data connections. For example, a PC client may have both a
5 modem and a network interface card; or a mobile client may have both a cellular and Wi-Fi connection.

[00112] Connectivity support is not limited to data connectivity. Connectivity support may also be for voice data as with ordinary cellular connectivity. Support for device communication, e.g., Bluetooth support, may
10 also be available.

[00113] Various embodiments of the client may support a full network stack. At the data link layer, client support may include, but is not limited to, Ethernet support for PC clients and Wi-Fi support for both PC clients and mobile clients. For Network/Session/Transport layer protocols, support may
15 include transmission control protocol/internet protocol ("TCP/IP"), user datagram protocol ("UDP"), and other protocols. For application layer protocols, file transfer protocol ("FTP") support for uploading large media files may be available, hypertext transfer protocol ("HTTP") may be available for web access, and simple mail transfer protocol ("SMTP") may be available for
20 email access.

[00114] Embodiments of the platform may support peer-to-peer connectivity, by which client devices may create an ad hoc network to access and trade files. In the alternative, embodiments of the platform as disclosed may also support dedicated networks. For example one remote client may
25 videotape an event and another client may record the audio of an event. The

remote clients may support infrared data association ("IRDA") standards and may be able to transfer files to each other. Since IRDA is slower than Wi-Fi, the remote clients may support Wi-Fi and set up a private ad hoc network between the two. Finally the remote clients may participate in a dedicated
5 network along with PC clients.

Extended Platform

[00115] Since multimedia files are large, even with compression, embodiments of the platform may create large amounts of data. Accordingly the data may be stored on cloud computing centers. By integrating with cloud
10 computing, the embodiments described herein may make available large amounts of storage and further provide access to compute-intensive applications available on cloud computing platforms. However, integration may result in degraded performance and over-reliance on a third party.

[00116] There are a number of compute-intensive applications that may
15 be hosted alone on large computer clusters. Face recognition is one such application. However, when such applications and databases are hosted on a cloud computing node, in addition to having higher availability of a larger number of compute resources, the application is not inherently networked. One application of the various embodiments described herein includes a client
20 camera capturing a video frame or still image, extracting out a subject's face using standard algorithms, and then calling a cloud computing database.

[00117] Fig. 6 indicates an exemplary implementation of such a scheme. Cloud 610 has a number of web servers, hosted applications, including but not limited to the face recognition software, and databases, including but not
25 limited to a database of faces. An application host 630 may include an

uploading web service but may delegate cloud computing requests to applications from non-cloud clients 641 and 642.

[00118] An embodiment of the uploading implementation may be described with respect to remote client 641, which has a still camera, and PC client 642, which has a number of still photos stored as files. PC client 642 with may store a number of still photos with the name of the person stored with the file as correlation metadata in the form of a tag. The PC client 642 may upload the photos to the application host 630 via a web service. The application host may then store the photos to central storage in cloud 610 where is the photos may be available for retrieval via search and correlation. In the alternative, PC client 642 may upload the untagged photos and then tag them with metadata after the uploading.

[00119] An embodiment of the download process may be described with respect to remote client 641, which takes real-time still photos at an event. The context may be in law enforcement surveillance or in photojournalism. Regardless, the user of remote client 641 may automatically tag the photo with the names of individuals on the photos. Remote client 641 may upload the photos to application host 630 via a web service which may then store the photos on a central store in cloud 610. Once on the web service, the remote client 641 may request the photos to be automatically tagged. The application host may then invoke a face recognition application running on the cloud to retrieve all photos that are similar to the faces in the photo uploaded from remote client 641. Where the retrieved photos do not have sufficient similarity to the photo uploaded from remote client 641, third party databases may be invoked. Based on the tags provided from PC client 642 as well as all other

clients that stored photos in the database, the relevant tags may then be applied to the photo uploaded by remote client 641.

[00120] Because the correlation and presentation are integrated together Fig. 2, item 220, custom features such as autotagging are available.

5 More importantly, because the embodiments as disclosed integrates with external data Fig. 2, item 230, and provides for metadata correlation Fig. 2, item 260, it can integrate with third party databases such as facial databases; including integration with cloud computing applications.

[00121] This integration with cloud computing applications provides for
10 faster responses. Accordingly, remote client 241 might receive the names of the individuals just taken in a photo immediately. Additionally, the remote client 241 might receive additional information such as company name or other professional information. On a variation of the above scenario, the user could have taken a picture of a product in a store, used object recognition
15 software in the cloud, and similarly retrieved product information. The foregoing is exemplary and not intended to be a limiting or exhaustive list of possible applications of extending the present platform to include cloud computing.

[00122] The integration of the described herein may not only provide
20 feedback regarding the accuracy of the facial recognition, but may also work to improve matches. For example, if clients 641 and 642 are organized into a group, the likelihood of retrieving false matches from a general database is removed by limiting the face recognition database only to members of the group. Furthermore, by adding autotagged photos to the general database,
25 especially after post capture corrections, provides an ever improving sample

of photos to determine facial matches. Facial recognition capabilities may be augmented by taking changes over time, such as hair style, and the growth of mustaches and beards, and could return name information but also time period information.

5 **[00123]** One problem with cloud computing integration is that data may be widely distributed geographically, thus creating wide variances in network latency and performance. For example, in Fig. 6, cloud 610 may be located in or near Seattle, WA but cloud 620 may be located in or near Washington, DC. Thus, a user located in Seattle would likely experience slow data retrieval if
10 the data were based in cloud 620 but better performance of data based in cloud 610.

[00124] Accordingly the application host 630 may manage offline, edge, and nearline data by (1) caching data on application host 630 itself and (2) invoking server affinity, which guarantees that a particular server, or at least a
15 particular cloud, is to serve data to a particular user. Data that is known to be needed commonly may be placed on the application host that is nearline. Data that is known to be needed by users geographically local to the cloud, but is not commonly used may be pinned to a local server or a local cloud via server affinity. Placing data redundantly on different edge points of the cloud
20 may not be cost or storage prohibitive because cloud computing provides large amounts of storage. Further, data that is not time sensitive may be stored offline or arbitrarily on the cloud.

[00125] Another problem with cloud computing is over-reliance on a single cloud computing provider. For example, where the central storage is
25 hosted on a cloud for a production system such as for law enforcement, cloud

failure means data storage is lost. If the law enforcement force was in a major city such as New York with 1,000 policemen on duty, down time of a cloud for 1 hour would be a loss of almost a man-year of data. Cloud computing is a relatively new technology, cloud computing brownouts and blackouts are possible. Additionally, much data, in particular in law enforcement scenarios must be made secure.

[00126] The application host 630 may integrate storage across clouds 610 and 620 from different cloud computing providers and mirror. Alternatively, the application host 630 may implement a RAID scheme, which may subdivide data across three clouds, all from different providers. Security, which may include auto-encryption, may be enhanced since no single cloud provider is likely to have all the data. In both cases, storage availability is improved.

Exemplary Client Software Platform

[00127] Fig. 7 illustrates an exemplary client software platform 700. The client software platform is based on an ordinary cell phone software stack. However, to support the custom applications, at each stage, a corresponding custom layer may be added. The main hardware interface may be the device drivers 710 and 720. Standard drivers 710 provide functionality to stock hardware. However, custom drivers 720 may be required for custom hardware. Typically drivers will communicate with the cell phone operating system 740. Examples include SYMBIAN (TM) and ANDROID (TM), the operating system for the Open Handset Alliance. The operating system 740, including the operating system kernel may require extensions 750 to provide support for custom software events, as an example. To provide the

necessary information to the operating system 740 and the extensions 750, software “shims” 730A and 730B may intercept and hook notifications from the drivers and may provide alternative functionality. Standards libraries 760 may be built upon the operating system.

5 **[00128]** For custom functionality, the exemplary platform may include custom libraries 770, mostly exposing programmatic support for the software eventing model 751, and to custom hardware as exposed by the custom drivers 720. Finally, applications 780 may be built on top of the libraries 770. The following discussion will cover each of these areas in more detail.

10 **[00129]** Standard drivers 710 may include drivers for stock cell phone hardware including, but not limited to, buttons 711, screen 712, and memory 713. There may be other stock hardware, including *e.g.*, a GPS receiver (not shown).

[00130] Custom drivers 720 may include drivers to support non-stock
15 hardware for a cell phone. Custom drivers may be included in various embodiments by which a mobile client comprises a cell phone with additional hardware functionality.

[00131] One example of a custom driver 720 is a custom network stack
20 721 to compensate for the presence of a partial network stack, as in various cell phone embodiments. However, full implementations are to support functions typically not on a cell phone including Wi-Fi connectivity, FTP, to name a few.

[00132] Other examples of custom driver 730 include a custom USB
implementation 722 and a custom Plug ‘n Play (“PnP”) implementation 723.
25 Not all cell phones support PnP, which is the automatic installation of

hardware drivers and automatic configuration and provisioning thereof. However, some cell phones may have additional hardware added for telemetry and metadata purposes. A full USB stack 722 and support for PnP 723 may provide such functionality in various embodiments. As USB is not
5 the only serial interface stack, it optionally may be replaced with some other serial data interchange stack.

[00133] Standard drivers 710 and custom drivers 720 may serve to forward communications to the operating system 740. Generally there will be an event queue and a series of modifiable event handlers (not shown).
10 Modification of the event handlers may include a recompilation of the operating system 740. An alternative is to create extensions 750 to the operating system 740 to isolate any necessary custom functionality. This includes a custom software eventing model 751.

[00134] Software events are different from the physical events that may
15 be captured via media and multimedia, in accordance with the various embodiments described herein. Other terms for software events include “triggers” and “notifications.” A software event may include a message that software sends when some occurrence discernable by software occurs. An example includes a hardware button being pushed, a driver triggering a
20 software event that sends a message to all applications subscribing to the event for which a button has been pushed. If an application has an event handler, that event handler will contain functionality as to what the application should do when a button is pushed.

[00135] A software eventing model may support software events for
25 custom hardware. For example, if a custom driver provides an interface for

an RFID trigger, the custom driver may send a notification to the operating system extension's internal event queue. The internal event queue may then forward the notifications through custom libraries 770 to application 780. The application 780 may then handle the event of the RFID trigger by turning
5 storing the camera's preview buffer and starting the record function of the camera. Alternatively, software events may be processed via a modification of the operating system's 740 event queue. Additionally, event notifications from applications 780 may be disseminated via the software eventing system 751.

10 **[00136]** The standard drivers 710 preferably are not modified, or are modified as little as possible and custom drivers 720 should be isolated from the operating system as much as possible. To enable custom eventing, in some cases, the communications may be intercepted or hooked by module 730A for the standard drivers and 730B for the custom drivers. For example,
15 if a particular button sequence is to bypass the operating system and perform a custom function such as a triggering a hotkey mode, it may be necessary to intercept the button pushes and redirect execution to a hotkey executable. Further by way of example, if a combination of the default operation and a custom option is required, the button pushes can be simply hooked thus
20 passing through the push notifications to the operating system at the same time triggering a custom button push software event handler.

[00137] The operating system 740 and the operating system extensions 750 generally will expose their functionality via an application programming interface (API). Standard libraries 760 generally provide function calls or
25 object models to aid programming applications. Standard libraries 760

generally are distributed along with the operating system. Library extensions, that is custom libraries 770 provide function calls or objects models to support custom hardware, operating system extensions 750, or to provide new additional functionality on top of the original operating system 740.

5 [00138] There is a wide range of applications 780 now enabled by this extended platform as will be described as follows.

(i) Patch Manager

[00139] Patch manager 781 is an application that handles updates for the drivers and installed software. There are two ways of patching. The first
10 optimizes saving memory, the second optimizes versioning. For both versions, the flash memory contains a lookup table mapping locations in memory for functions. When an application calls a function, it goes to a lookup table that was populated by the table mapping from flash. In this way, the function can proceed to the location of the function and properly execute.

15 [00140] The first example of patching stores the lookup table values in a well known location. It then stores drivers, the operating system, applications, and any other binaries in other locations of the memory. Each binary is allocated more memory than it currently needs in order to account for future patches. When the patch manager receives notice, which includes all new
20 binaries and a new lookup table, perhaps over the network, or via an SMS message, the patch manager triggers a software event. The software event shuts down all software except for those necessary for patch functions. The patch manager first overwrites the lookup table, and then overwrites all binaries with the new binaries. The patch manager then forces a reboot. The
25 reboot then restarts the mobile client, populates the software lookup table with

the lookup table in flash. When an application calls a function, it then will go to the new location and to the new binary.

[00141] While the first example conserves memory, it does not provide provision for falling back in the event bad patches are installed or patches
5 were improperly installed. In a second example of a patch manager, the same triggers and events are used as in the first example. However, additionally, the location of the current lookup table is stored. At a well known location, several bytes of empty storage store each new location of lookup
10 table. The original lookup table address is in the first location. The lookup table of the first patch is in the second location, and so on. Whenever a patch is installed, lookup table and all binaries are stored contiguously. Upon reboot, the operating system looks for the last lookup table and then installs the lookup table into software from that location. In the event a patch has to
15 be backed out, the patch manager can decrement the list of addresses of lookup table versions, reload the older lookup table, and in doing so revert back to the older software.

(ii) File Manager

[00142] File manager 782 is an application that provides advanced file management for on board removable storage. Typically when removable
20 storage such as memory sticks are in a cell phone, the assumption is that the user will remove the memory stick and place it in a PC to remove and otherwise manage files. However, for scenarios such as security cameras where removing the memory stick may take long periods of time, an ability to manage files as not to run out of memory is required. To address these
25 requirements, the file manager 782 contains four main functions: (1) deleting

files upon upload, (2) round robin deletion, (3) metadata tagging upon upload or download, and (4) enumeration of data assets.

[00143] For the first function, as files are written to media, eventually a notification, perhaps from SMS will trigger uploading all files not currently
5 open. Where a file is open, optionally the trigger will force a closing of a file and a reopening, for example with the onboard video camera is currently recording.

[00144] For the second function, where uploading is sporadic or non-existent, the file manager may maintain a queue of files and implement a first
10 stored first out memory management approach. Specifically, when memory is no longer available, the oldest files will be deleted and that space allocated for a new file. The file manager may implement packing and compression algorithms as well.

[00145] For the third function, upon upload or download the file manager
15 checks the Event ID of the data asset. If it is null, it populates the metadata field with the current Event ID on the mobile client. Where the Event ID is associated with other metadata, for example the name of the event, that field is populated if null. In the alternative, it may prevent upload or download.

[00146] For the fourth function, the file manager provides not only for
20 enumeration of data assets, but simple search via metadata. The file manager maintains a table of data assets on the machine and maintains a list of metadata fields and offsets. When request, for example from SMS, or alternatively via a network requires a list of data assets matching metadata criteria, it sequentially iterates through all the data assets in the data asset
25 table and retrieves the file name if the data asset matches. It then writes the

file name into a text file. The text file is then returned over the data connection. The text file may be formatted with XML or with a proprietary format to aid enumeration and presentation on the receiver of the file.

(iii) Quality of Service ("QoS") Failover

5 **[00147]** A QoS Failover application 783 manages multiple media inputs, for example a video camera and a microphone. Consider the case where the mobile client is in a police car and the police officer is wearing a wireless video camera and a wireless microphone configured for the platform as disclosed. Further consider the case such that the video wireless connection
10 has a lower range than the microphone wireless connection. While the police officer is near the car, both video and microphone are streaming data. When the officer exceeds the distance for the video connection, but not the microphone, the QoS Failover application can cut-out storage only for microphone. When the officer then exceeds the distance for microphone, the
15 QoS Failover application can then place a marker in the file indicating no receipt. When the police officer returns to the car, the microphone and video can recommence recording according to range.

(iv) Client Synchronization ("Client Sync")

[00148] Consider the case where data assets from multiple mobile
20 clients are to be correlated. The Client Sync application provides the client side support to aid consistency and reliability of media and metadata across the clients, hence the term sync. Upon activation, the Client Sync registers the mobile client with a web service or equivalent. The web service provides an Event ID and in turn the mobile client via the Client Sync uploads data
25 assets to the web service. The data assets are tagged with the Event ID. The

Client Sync also provides location samples to the web service, as to allow for tracking of the mobile client. When data assets are uploaded, the Client Sync also appends to the data asset a checksum. Upon upload, the web service can validate the authenticity of the uploaded data asset. The checksum (also
5 called a heartbeat) can also contain additional metadata. For its part, the web service can also provide additional metadata. For example, consider a law enforcement scenario with multiple officers. Each of the officers has a mobile client and already is associated with an Event ID. When a particular incident occurs, the web service can provide an Incident ID that gets associated with
10 the officers proximate to the event. This Incident ID gets associated with all data assets uploaded until the web service rescinds the Incident ID. In this way, later the data assets associated with the Incident ID may be easily identified.

[00149] Identifying relevant mobile clients to send the Incident ID relies
15 on knowing the location of the mobile clients. If an officer indicates that an incident has occurred, either through a hotkey or a message, the web service attempts to identify which other mobile clients with the same Event ID are proximate. Usually this may be done via GPS. However, as described in the hardware section above, GPS is prone to error from GPS signals bouncing off
20 of buildings, location may alternatively be determined by triangulating signal strength or weakness from different cell towers with known locations. For relatively immobile clients, such as surveillance tower cameras, geolocation via IP address may be employed.

(v) Remote Control

[00150] The remote control application 785 takes advantage of the full network stack on the mobile client. Consider the case where the mobile client has an IP address and is fully participating on a network. The remote control
5 application contains a proxy to intercept remote instructions, either through SMS or from a direct IP connection to a remote site. Accordingly, a remote user can fully control the client, either for maintenance such as patching and upload of data assets.

(vi) Preview

10 **[00151]** The preview application 786 is not an application to preview data. Rather it is an application to guarantee that media captured in the preview buffer of a video camera is recorded along with the rest of the event. On video cameras with preview, a memory buffer stores the first few seconds of data. This buffer could store an arbitrary amount of time. Upon recording,
15 the video begins recording at the time of triggering, in other words at the start of the event to be recorded. However, for security cameras and other applications, it may be preferable to store the previous few seconds in the preview buffer as well to ensure complete recording. Accordingly, a RFID triggered security camera function in a mobile client configured with the
20 platform as disclosed would store not only the event upon triggering the camera, but also the first 10 seconds. In this way, the video would store not only the event, but the precursor events that led to the event.

(vii) Custom Charger

[00152] Mobile devices such as the mobile client as disclosed require
25 constant recharging. A custom charger application 787 determines how much

charge is left in the battery, and provides alerts when charge is low. Furthermore, in cases of inductance charging, the custom charger can store information about how much power is needed to recharge the battery. It could also store rules on detecting when charging coils were sufficient proximate
5 and stable to trigger charging functions.

(viii) SMS Based Mobile Client Control

[00153] The ability to receive short message system (SMS) messages and trigger software events provides a general mechanism to remotely control a phone. Specifically, a mobile client that has an SMS capable transceiver
10 may monitor SMS calls and perform software routines in responses. Specifically, one of the custom drivers 725 could be an SMS driver to allow the ability to monitor SMS calls for custom commands. Calls to and from the SMS driver could be intercepted and hooked. When a predefined SMS message to a predefined location is received, it could trigger an event in event
15 model 751 which in turn could be utilized in an application 788.

[00154] An alternative embodiment is to have a daemon application 788 without the driver or event model to directly monitor SMS messages such that when a predefined SMS message to a predefined location is received it would perform a particular prespecified task.

[00155] An example application for monitoring SMS messages relates to
20 law enforcement. A "stealth" recording feature may be implemented where a mobile client receives a SMS message which includes a phone number, the SMS message instructs the mobile client to start recording its environment and transmit the audio and/or video over the received phone number.
25 Another SMS message could instruct the mobile client to stop recording and

transmitting. Variations on this scenario where an SMS message instructs the mobile client to initiate a phone call but does not record, as to the type of media to transmit, and whether to use the calling number as the destination to transmit recorded media will be appreciated by one of ordinary skill in the art.

5 **[00156]** In particular, Table A as follows provides an exemplary mapping of events to SMS Messages to be interpreted a control instructions operative to control a mobile client's stealth recording function:

	Event	SMS Message	Description
	Recording Start	#*77	Start recording media
10	Call Start	#*27 + phone #	Initiate call to phone #. If phone # is not specified, then initiate call on the sender's phone #.
15	Recording/Call Start	#*7727 + phone #	Initiate call to phone # and start media recording. If phone # is not specified, then initiate call on the sender's phone #.
20	Recording Halt	#*74	Terminate ongoing media recording.
	Call Halt	#*24	Terminate ongoing phone call.
	Recording/Call Halt	#*7424	Terminate the ongoing media recording and phone call.

25 Table A. Event to SMS Mapping for Stealth Feature

[00157] The mobile client may optionally send a response SMS message to the sender to confirm receipt of messages, proper operation of the client, or error messages. The SMS messages could be used as a protocol, including but not limited to triggering software events by the receiver.

30 For example, an SMS acknowledgement for starting a call could trigger a

software server to start receiving streaming media. Another example would be to receive an error SMS stating that a connection could not be established, and displaying the error message as part of a computer application.

[00158] The mobile client could receive SMS messages from any SMS
5 source. These include but are not limited to other mobile devices and computer applications with a cell that could transmit SMS. Accordingly, protocols could be established over SMS between two mobile devices or with a custom computer application with capable of transmitting and receiving messages compliant with the SMS protocol.

10 **[00159]** Although the SMS messages above are merely exemplary, a sample session may be as follows. The mobile client receives an SMS message `#*27 1-555-555-1234`. In response, the mobile client starts a phone call with 1-555-555-1234, and immediately sends an SMS acknowledgement. The mobile client then receives an SMS message of `#*77`. The mobile client
15 immediate starts recording video and audio. If the recording cannot be performed, the mobile client would send back an SMS error message to 1-555-555-1234. Periodically, the mobile client will upload files to an FTP server or other host. Alternatively, the calling number 1-555-555-1234 could provide a connection to an FTP server or equivalent. In another alternative,
20 the server to which 1-555-555-1234 provides connectivity could trigger a streaming receipt upon receiving the acknowledgement SMS from the mobile client. The mobile client, upon receiving `#*74` and send an acknowledgement SMS and would halt recording. A new recording could be established the mobile client receiving `#*77` and again halted by the mobile client receiving

#*74. Similarly upon receiving #*24, the mobile client would stop the call and send an acknowledgement.

(ix) Other

[00160] The above applications are not intended to be an exhaustive list
5 of applications available. General utilities such as profile management (not shown) are available. A profile manager could store user information such as name to be used as default metadata. It could also store results about memory usage, bit rate, and resolution of stored media.

[00161] Commercial utilities can also be implemented on this platform.
10 For example in the case of law enforcement, the mobile client might have a hot key for a police officer to indicate the officer has been attacked or shot. The video would trigger to store the preview buffer as well as the current events, and a central station could call for backup asking other police to converge on the attacked officer's GPS location.

15 **[00162]** Another law enforcement example is the alternative log on/password utility for undercover policemen. The alternative log on/password utility accepts two passwords. One password activates all the law enforcement functionality on the mobile client and displays a user interface specific to the law enforcement functionality. A second password
20 simply displays an ordinary user interface expected on an ordinary cell phone, and additionally may activate a call for backup to the central station. Specifically, when an undercover policeman begins to be suspected to be a cop by those he or she is investigating, the policeman might be searched. Ordinarily, if the policeman is searched, and the mobile client is found, an
25 inspection of the mobile client might arouse suspicions that the undercover

policeman is a cop. The undercover policeman could enter a the second password into the alternative log on/password utility while would show the ordinary cell phone user interface and may help convince others that the undercover policeman is not a cop. In the meantime, the backup call to the
5 central station would allow other policemen nearby to rescue the undercover cop.

[00163] Commercial utilities are not limited to law enforcement. The mobile client may support applications not specific to its video or networking capabilities. An example of a commercial utility not specific to law
10 enforcement is where the client could store an audit function (not shown) that indicates that an unauthorized person has attempted to open the tamperproof chassis. An example of using the SMS based mobile client control feature, such as used by the Stealth feature described above, is the case of a lost mobile client. The mobile client may host an application that upon receiving a
15 message, such as an SMS text message, may un-mute a mobile client with its ringer turned off or alternatively may activate a mobile client that is in sleep mode, and then ring the device. In this way, a mobile client that has been misplaced in a room, where the ringer has been turned off or cannot otherwise be located simply by dialing the mobile client's number.

20 Exemplary Non-Client Software Applications

[00164] Once the data assets are tagged and available on a central store, they may be searched, correlated, tagged, edited, and presented either collectively via a web service, or to a closed set of users via a standalone application. The platform as disclosed gives rise to both types of applications.

[00165] Regarding a web service, groups may correspond to a group. The data reviewed by the groups, the content of the tags, and comments, made by the group may be queried for possible advertising. Because the group is self selecting, the fit of ad selection will improve a selection algorithm, based strictly on scanning media content, and metadata. In Fig. 2, the external data store 230 as provided with correlating metadata in 260 could be the correlation of advertising.

Network Operations Center

[00166] Figs. 8A and 8B show a non-client based commercial application of the present platform, a network operations center (“NOC”) of a law enforcement agency.

[00167] The NOC provides the capability of viewing individual videos. In video feed 810, a video, or potentially another form of multimedia will be rendered. Annotation tools 811 provide allow a user select one or more frames of running video, superimpose text, links, or other content, perhaps associating to a single object, such that the annotations render upon playback. Many tools presently exist for annotation of video and multimedia in general. Running commentary box 820 provides a control with which to view commentary and commentary edit box 830 provides a place to add additional commentary. Commentary text is persisted to a database and is associated with the multimedia file being rendered. Commentary is distinct from annotation in that the text is visible at all times in the running commentary box 820 during rendering, whereas annotation only appears for specific frames and is superimposed over video as rendered in the video feed 810. Associated videos, stills, text or other multimedia may render at the same time

in browser 840. For example, links from the annotation may render in browser 840. Map 850 may also display the location of the video. For example, if the video is by a police car in hot pursuit, the map may show a point rendering geolocation of the path of the pursuit itself.

5 **[00168]** The NOC has a “supervisor mode” shown in Fig. 8A, where data feeds, including video and audio, are coming from police officers proximate to an incident. Specifically, a police officer encounters an incident and presses a hot key telling the NOC that an incident is under way. The NOC can start an incident record and the police officer’s feed appears in Car Feed 1, item 851.

10 Because it is the first feed, it also appears in the main video feed 860. The map 880 then centers on the location of that particular officer. The incident ID may be used as an Event ID.

[00169] On the map, the user can view other officers near to the incident and can either manually select other officers individually by clicking on the
15 officers, or by dragging and dropping a bounding rectangle over the location. In the alternative, the application can use a predefined distance and automatically join other officers. Each joined officer’s feed then shows in feeds 861, 862, 863, 864, 865 and so on.

[00170] When an officer is joined, the officers’ feed is associated with
20 the Event ID and defines a group. Thus joining officers within a predefined distance and unjoining officers that go out of that predefined distance is an autogrouping feature.

[00171] The main video feed 860 may display which of the feeds 861, 862, 863, 864 or 865 to concentrate on. Alternatively, the main video feed
25 may automatically switch between which officer is closest to the incident.

Note that the video feed is not a composite view, but rather is an example of multiple videos being shown side by side based on correlation metadata.

[00172] If the data is being viewed after the fact, browser 870 can bring up data from the law enforcement's case database. All media files with the
5 Event ID may then be automatically tagged with the Case ID from the case database. In this way, data from the case database may be provided in an integrated view along with the media.

[00173] Law enforcement mobile clients have redundant local storage that is eventually uploaded for archiving. The application can provide a
10 scanner function (not shown) that can manage uploading from the mobile clients, can tag the file as archived thus preventing redundant storage. In the alternative the scanner function could seek similar clips based on Event ID and location and timestamp information and delete redundant clips.

Because of the redundant storage, the NOC can provide security functions.
15 Specifically the scanner function could also detect files tampered with by noting files with the matching data with different checksums. Additionally the NOC can check checksums on uploaded files to detect files intended to spoof the NOC.

Vertical Applications

20 **[00174]** The embodiments as disclosed may be used for both personal and commercial vertical applications. Advantages include but are not limited to: (1) reducing the price of camera monitoring via use of commoditized ever miniaturizing hardware and ever cheaper storage, (2) guaranteed full capture of an event by implementing preview buffers, (3) custom eventing where a
25 camera may be triggered on an arbitrary event, (4) integration with other

media via correlating metadata, and (5) integration with third party data via correlating metadata. The following sections will describe an exemplary application for personal use, an exemplary application for law enforcement, an exemplary application for security cameras, and will more generally
5 enumerate other exemplary commercial scenarios.

Mobile NOC

[00175] The NOC application may be accessible via a web page on a notebook computer or other web enabled mobile device. Accordingly, all or portions of the NOC application may be viewed while in the field by a law
10 enforcement officer.

[00176] An example application would be allowing a junior officer to patrol an area and to view indicia of incidents that occurred within a time frame in the present locale. In this way, the officer could more quickly learn the crime history of his location even though he had never been in the area
15 before.

[00177] One embodiment would be to let an officer travel through a neighborhood. The officer would enter a time range of data to browse for the area, for example over the past year. The NOC application would pick up geolocation information of the roaming officer such as GPS location and
20 display a map in the NOC would show pushpins indicating incidents within the specified time frame. The pushpins could be color coded, or have size or shape changes indicating the severity or recentness of the incidents. The officer could click on the event and view the video or associated media to learn more. In this way, the officer could familiarize himself as to the crime
25 history of an area in near-real time.

[00178] The mobile NOC need not be in real-time. An officer could be in an area, and if he wished to learn more about the crime history of his location, he could open the NOC application and specify his current location and search for crimes within a time area and various search criteria. In this way,
30 upon entering a crime scene the officer might find related crimes not readily discernable from the crime scene itself. For example if there was an assault at a crime scene, the officer could quickly identify other assaults nearby and

consider suspects from those crimes as well as leads from the present crime scene.

Peer to Peer Scenario Embodiment

[00179] Video cameras, digital cameras, and digital recorders are to be
5 ubiquitous among law enforcement officers. It is not uncommon for several
policemen, each with their own camera or recorder, to be proximate to a crime
in progress. The embodiments as disclosed enable sharing and the
automatic correlating of the resulting data assets.

[00180] Fig. 9 illustrates a scenario where three police officers, one with
10 a personal camera 923, the other two with cell phones enabled per the
disclosure 921, 922, are proximate to the same crime scene 910 in progress
and start taking photos. The still shots capture different parts of the crime
scene 910, some overlapping, some not. Mobile client 921 captures still shots
931, mobile client 922 captures still shots 932, and digital camera 923
15 captures still shots 933.

[00181] Because mobile clients 921 and 922 are enabled per the
disclosure, they are able to perform a peer to peer connection. Per the
embodiment as disclosed, the initiating client 921 identifies its device id, and
enters a tag called "Robbery 1" and sends both to 922 to use as an Event ID
20 and as extra metadata. Mobile client 922 sends an acknowledgement back to
921, thus fully establishing data link 940. Mobile client 921 then downloads
via IRDA all photos time stamped during a time frame corresponding to that of
the crime from 922, and mobile client similarly downloads all photos from 921.
Both clients automatically tag the photos moved through the data link 940.

25 **[00182]** Standard camera 923 is not configured per the present
disclosure and cannot perform peer to peer transfer as mobile clients 921 and

922. Instead, the users of mobile clients 921 and 922 establish a group (not shown) on web service 960 using mobile client 921's Device ID as an Event ID. The user of standard camera 923 then joins the group and when standard camera 923 uploads chosen photos to the web service over data link 953, the photos are automatically tagged with the Event ID and the meta tag "Robbery 1."

[00183] A user, such as a police supervisor back at headquarters, who is a member of the group (not shown) subsequently may access the web service 960 via a PC 970 over a data link 980. The user may further upload related photos, such as getaway scenes of the robbery crime scene 910 of persons of interest driving away, and again via the data link the photos are automatically tagged with the Event ID and the meta tag "Robbery 1." The user may also query, edit, tag, and combine photos on the PC.

[00184] It is to be emphasized that in the above scenario, media is not limited to photos. Video or audio could have been uploaded as well. The web service could have been a standalone application running on a network. Most importantly, the event, here exemplified by a crime scene 910, need not have been at the same time or place. An Event ID could tie together any media regardless if they previously were related at all.

20 Law Enforcement Scenario Architecture Embodiment

[00185] Fig. 10 illustrates an exemplary law enforcement architecture embodiment. Consider the case where multiple active duty police officers are carrying mobile clients per the embodiments as disclosed. Police officers on foot carry a mobile client 1010, and police cruisers carry a mobile client 1030 in a chassis where the video camera is connected to the windshield, and the

data is stored in a tamperproof, secure location. Exemplary tamperproof, secure locations include the trunk of the vehicle or glove box of the vehicle. In particularly hot climates, the trunk or glove box could be become so hot as to be beyond the operating temperature range of the data storage hardware
5 portion may be in a secure cage integrated with the chassis of the vehicle, in a shaded and ventilated portion of the backseat. Alternatively, the tamperproof secure location could be integrated with cooling, such as an insulated cavity with refrigeration powered by electricity from the vehicle. Host 1020 provides data asset storage and archiving and backup services.
10 Supervisor application 1040 is based on Wi-Fi connectivity and is hosted on a PC in a NOC. Both mobile clients 1010 and 1030 and the chassis of 1030 are based on the exemplary client described in Fig. 5 and supporting text. The supervisor application is as described in Fig. 8B and supporting text.

[00186] Host 1020 receives data assets from mobile clients 1010 and
15 1030 both in synchronous and via asynchronous upload. A web service 1021 can remotely configure a mobile client 1010 by checking the existing profile 1011 sending an updated profile via client application 1012. In general, client application 1012 functionality includes providing network connectivity to the host. The profile includes and is not limited to frequency of receiving an IP
20 signal to poll the status of the mobile client. This signal is also called a heartbeat. Upon configuration, web service 1021 will send out a heartbeat according to that frequency, for example every 15 seconds. Client application 1012 will receive the heartbeat and return geolocation information, such as GPS coordinates. In the event of connectivity error, website 1027 would be

able to indicate which mobile clients 1010 and 1030 have failed to connect or have not transmitted a heartbeat.

[00187] Because a mobile client 1010 and 1030 in the field broadcast geolocation information, a network operating center (“NOC”) can get mobile location information from the host and know in real time the location of mobile units. This enables map applications. For example a NOC application may display selected units on a computerized view of a map, perhaps accessible via a web site 1027. Alternatively, particular mobile clients may be searched by geolocation. By way of another example, the NOC can have the location of a crime scene and the current location of a mobile unit 1010 and automatically map the optimal route for the mobile unit to get to the crime scene. This feature is also known as a “Get Me There” feature.

[00188] As client application 1012 captures media, it stores the corresponding data assets on storage 1013. Via synchronizing application 1014, the mobile client 1010 may either push the stored media via file transfer protocol (“FTP”) to the file transfer server 1022, or the synchronizing application 1014 may be remotely triggered, for example via an SMS command, to affirmatively upload the stored media as data assets.

[00189] Once the data assets are uploaded to file transfer server 1022, a crawler application 1023 periodically scans the uploaded data assets. The data assets are placed into a folder queue and optionally associated with metadata, for example in the form of metadata tags corresponding to incident, or case. Transcoder 1024 converts the file formats of the data assets into a standard format, for example one based on H.264. Once transcoding is completed, if the transcoding is successful, crawler application 1023 archives

the original file and stores the transcoded video to store 1026 and a reference to the transcoded video to database 1025. In the event of error, the uploaded data asset is placed into another directory for later review.

[00190] One error that may occur in particular with data assets stored as H.264 compliant files is the loss of the file index. A file might be partially uploaded, but because the file index is stored at the end of the file, none of the partial uploaded file is usable. Prior to transmission, synchronization application 1011 might store the H.264 index in a separate file, and redundantly upload the index. Because the index is much smaller than the media data in the H.264 file, corruption is less likely. In the event the uploaded H.264 file is truncated, the complete index, uploaded separately may be used to decode the portion of the H.264 file that arrived. If the H.264 file arrived intact, then the redundant index may be discarded.

[00191] Once data assets have been stored in the database 1025 and store 1026, they are accessible via a website 1027. The website may include functionality to search and view videos including external data such as case data. For example, it may enable "computer aided dispatch", where an officer is dispatched to a crime scene, incident information is entered by the dispatch via website 1027 and uploaded to database 1025, data assets are uploaded from mobile client 1010 or 1030, tagged with metadata corresponding to the incident, and the searched and viewed in composite afterwards.

[00192] Website 1027 may also provide various ways to quickly review video files. For example website 1027 might provide thumbnail or videocap views of videos to aid visual search. In some cases, a scroll bar might be

displayed to allow the user to scan through individual frames in the video, rather than merely viewing a default frame.

[00193] Website 1027 may also integrate with external websites. For example, a supervisor may access website 1027 and upload a video to a public social networking site as part of a public alert such as missing child alert (“Amber alert”).

[00194] Website 1027 may also provide visibility to monitor the status of uploaded data assets, and provide for bandwidth management and prioritization. For example, website 1027 may show what data assets have been uploaded, transcoded, or what percentage of the process is complete. It may also show which data assets have errors or are otherwise corrupt. Specifically, the website 1027, may review the contents of the file transfer server 1022 directories which store uploaded data assets, archived data assets, and corrupt data assets. It may further receive notifications from crawler application 1023 as to what percentage of an operation such as transcoding is complete. If a data file is to be prioritized for upload or transcoding, the website 1027 might provide a control to configure the crawler application 1023 accordingly.

[00195] Mobile client 1030 shows an alternative architecture for a client. Here car service 1031 combines the functionality of client application 1012 and synchronizing application 1014. Additionally, it provides network connectivity to a supervisor application 1040. Supervisor application provides the ability to provide remote control over client 1030 and to view configuration, status, and stored data assets on client 1030. On mobile client 1030, the mobile configuration and the captured data assets are stored in the same

store 1032. Data assets are captured and reviewed locally by application 1033.

[00196] The following describes features and advantages enabled by the platform as disclosed for law enforcement.

5 (i) Chain of Custody

[00197] Police and security video may be used in evidence at trial. However, in order to be admissible, the evidence must be stored such that an unbroken chain of custody can be made, ensuring that the evidence was not tampered with. With the embodiments as disclosed, a metadata tag to store
10 an Officer ID and a metadata tag to store a timestamp and action may be made. When the police video is stored, the tag stored the Officer ID of the owner of the mobile client. When the officer uploads for storage, the officer authorizes the upload which again tags the police video with Officer ID, timestamp, and action. When the data is received and archived, the archival
15 officer may again tag the police video with his Officer ID, timestamp and action. Thus at all stages, the chain of custody of the video may be verified. For further security the metadata may be encrypted. Alternatively, checksums may be archived in a database to detect later tampering.

(ii) Providing Video ID

20 **[00198]** Because all video is uploaded and archived, citizens who have been stopped may request an identifier for the video clip capturing their stop and a limited access account. The citizen may then go to the law enforcement agency's web site, log on, and then view the footage of their stop. This will provide an incentive for officers to avoid excessive force and
25 can provide evidence for and against any culpability.

(iii) Monitored Interrogation

[00199] When suspects in custody are interrogated by police officers, typically there is a camera to memorialize the event. However, a determined police officer can disable a typical security camera. If a mobile client enabled with RFID and preview is in the room, it will be difficult to tamper with the camera. Specifically, an officer with an RFID badge enters the interrogation room. The RFID badge not only triggers video recording, it also makes use of preview mode to capture the first 10 seconds prior to entry. Therefore, even if the officer were to tamper with the camera, the camera would have captured the first few seconds and would detect the tampering.

(iv) Emergency Dispatch

[00200] Often officers enter hazardous situations. When an officer is assaulted, the officer may hit a hotkey on the mobile device that acts as a panic button. The mobile client sends a notification that includes the officer identity and the officer's location which then goes to the NOC. The supervisor mode of the NOC includes map showing nearby officers which are also broadcasting their locations via GPS or other location services. The officer at the NOC may then quickly dispatch the proximate officers to the location.

(v) Blackout Versions of Video

[00201] Police videos are often used as evidence in trial. The embodiments as disclosed support post process editing of videos. Because it may be desirable to black out portions of video as unfairly prejudicial, both district attorneys and defense lawyers may edit out or black out portions of the video to be left out of the trial record. One way to do this is via professional post processing tools. A less expensive alternative would be to use an overly

tool (a block of non color over top of the video) to place overlays blocks over the portions of the video to be blocked out. In this way, not only could portions of frames be provided rather than full blackout, faster turnaround of editing could occur.

5 Security Camera Scenario Embodiment

[00202] A variation of mobile officers carrying mobile clients is to have a mesh of security towers covering a geographic area. This would enable close circuit surveillance over an arbitrary area with minimal installation costs. Examples of locations where these may be applicable include but are not limited to be college campuses, airports, prisons and high crime areas. It is to be noted that a mesh of camera towers need not be limited to law enforcement scenarios. For example, a mesh of camera towers at a sporting event or an entertainment event would provide improved media coverage of the event. Each of the towers would have a mobile client configured with a full network stack to allow remote control over IP and Wi-Fi and a file manager to manage file upload and file deletion. Both the network stack and the file manager are discussed in Fig. 7 and the supporting text.

[00203] Each camera is network enabled and is independent in that it is a self contained recording and storage device that adds metadata such as time and location. Because the cameras house these on board capabilities, all that is needed locally is power. No communication cabling would be required.

[00204] Each camera could be configured to host a synchronizing application that was able to detect proximate cameras. An embodiment would

be to refer to a web service that tracked the location of each installed camera, and from knowledge of its local location, could select proximate cameras.

[00205] To aid in backwards compatibility, where a camera did not have the necessary hardware initially, a hardware block with the missing hardware, 5 e.g. to enable network connectivity, could be attached, and the necessary software components installed. Accordingly, previously purchased hardware could be made to be compatible for mesh applications.

[00206] However, collectively the cameras act together as a mesh of cameras that give a law enforcement agency a comprehensive view of what 10 happened at the same location or close by locations at the same time. A NOC's supervisor mode could quickly search for all uploaded data assets from the camera at a particular time and location, and then view and edit them together.

[00207] Note that the cameras all networked peer to peer devices. 15 Accordingly, an officer could come to a location where there were several devices present, such as the scene of a crime or other event, and could determine on his laptop or cell phone the locations of all the cameras. The officer could then choose cameras to download video to his laptop or cell phone, or by default download all videos from the surrounding cameras.

20 **[00208]** A camera need not start out as part of a mesh. A camera may operate independently until another camera is added to the network to establish a mesh. Thus a single camera, perhaps mounted on a pole, could provide ad hoc surveillance in a relatively short period of time. As time went on, other cameras could be incrementally added to establish a mesh. 25 Cameras could also be removed as necessary.

Sports Replay Scenario Embodiment

[00209] A non-law enforcement scenario for using mesh is to replay sports games. Professional and other sports team's videotape games and practices to better assess points of weakness and to identify ways to improve
5 the team and individual player's performance. An ability to view a play or action from multiple angles would provide a comprehensive way to assess the action.

[00210] By providing a mesh of multiple cameras incorporating the disclosures herein, multiple cameras may synchronize to the same clock. If
10 four surrounding cameras were configured to view a play and were synchronized, the configuration would provide a quad view. Alternatively, cameras in the mesh could provide a mix of different views, for example a coach's view, views from two different players, and perhaps two sideline shots.

[00211] Per editing software using the metadata features disclosed herein, metadata specific to game analysis indicating for example the particular play, the context of the game and players involved could be added. For example for a football game, metadata indicating that a particular
15 segment of media represented a first down, a running play, where Jones was the runner could be added. In addition to providing context upon playback, it
20 also provides metadata enabling searching and filtering on kinds of plays, players, and other elements of interest in analyzing the game.

[00212] The game analysis metadata need not be rendered, but could also be used for statistical analysis of the game. One could determine
25 likelihood of how a team or player reacted according to different situations.

For example in football, one could determine that a team was significantly more likely to do a long pass on a first down than other teams.

[00213] Cameras using the present embodiment have a sharable format, thus different teams could agree to share media with each other. Because
5 the camera's clocks could be synced to a global source, e.g. a web accessible value of global time, the different media could be synchronized with each other, even though they had been recorded separately by different parties. Accordingly, different views designed from different perspectives may be correlated together.

10 Other Possible Commercial Embodiments

[00214] Commercial embodiments are not limited to law enforcement. The following are some other commercial scenarios supported by the platform.

(i) Taxicab Scenario

15 **[00215]** The embodiments as disclosed can replace a taxicab's meter box and camera with a single device. Currently, most taxicabs install a meter box to show the fare charge. Some taxicabs also install a camera to show the face of the driver to the passenger. However meter boxes only show charges, not distance, route, or other information that may be of interest to the
20 passenger.

[00216] A taxicab hosted client as disclosed, with a video camera and a GPS or other geolocation tracker, integrated with a map database and an external charge database may perform the roles of the meter box and camera for a lower price and with greater functionality including but not limited to: (a)
25 a view for the passenger with start and end points on the map, with the

specified route as calculated by software also shown so the passenger could proactively request a different route; (b) the passenger view displaying progress on the route by showing the taxicab's GPS tracking samples as the trip progresses; (c) the passenger view additionally showing not just taxicab fare information, but also time and distance information, traffic alerts, predictions of arrival time; (d) a log of the trip could be stored and uploaded via the mobile connection, or in the alternative could update via Wi-Fi upon parking, in order to provide an audit trail to a central office; (e) the passenger view could provide average trip times and other aggregated information from the audit information; (f) the client integrated with a printer could give a receipt with the information from the view upon request of the passenger; and (g) uploaded audit information could be used in training new taxicab drivers.

(ii) School Bus Scenario – Child Tracking

[00217] The present embodiments could monitor pickup and drop off of children. Currently typical school buses do not have onboard cameras. Accordingly, determining whether a child was dropped off at the correct location on the way home, or in the alternative determining if a child was correctly picked up relies on the bus driver's memory. In the case of a missing child, the camera could provide objective evidence as to whether the child was on the bus or not.

[00218] A school bus hosted client of the present embodiments with an eventing system for door opening and closing, a video camera with preview, and a geolocation tracker, integrated with a map database includes but is not limited to the following advantages: (a) when the school bus door opens or closes, the custom eventing system could trigger recording of the video

camera; (b) the video camera would have several seconds of preview buffer, so would record a those several seconds along with the actual event of a child entering or exiting the school bus; (c) the custom eventing system could trigger turning off the video camera; (d) the geolocation tracker could trigger
5 upon turning on the camera as well and along with a map database indicate where the pickup or drop off occurred; (e) the information could be archived to a central office via cellular upload or Wi-Fi; and (f) the archived information could be aggregated for statistics and in where no errors of pickup or drop off occurred, the information could be deleted to save storage.

10 (iii) Trucker Scenario

[00219] The present embodiments could monitor accidents for bulk transportation such as semi-rig trucks. Currently semi-rigs do not have onboard cameras. Accordingly, disproving the liability of a semi-rig in the event of an accident is difficult.

15 **[00220]** A truck hosted client of the present embodiments with an eventing system triggered by a vehicle crash detector such as disclosed in U.S. Patent No. 4,161,228 which triggers airbags, a video camera with preview, a geolocation tracker integrated with a map database includes but is not limited to the following advantages: (a) when the vehicle crash detector
20 detects a crash, the custom eventing system could trigger recording of the video camera; (b) the video camera would have several seconds of preview buffer, so would record a those several seconds along with the actual event of the crash; and (c) the geolocation tracker could trigger upon turning on the camera as well and along with a map database indicate where the accident
25 occurred and upon upload could notify a central office as to dispatch a

response team. Additional advantages may be realized by further integration with a telematics system which provides additional digital telemetry about the state of the truck. For areas that did not have cell phone coverage, alternative data transport such as packet radio could be implemented.

5 (iv) School Bus Scenario – Accident Tracking

[00221] As a hybrid of the previous School Bus and Trucking scenarios, an embodiment of the present disclosure could monitor accidents on school buses as well. Currently school buses do not have onboard cameras. Accordingly, determining causality and harm to children on the bus is difficult
10 to prove.

[00222] A set of school bus hosted clients as described by the present disclosure, specifically with one or more cameras recording events outside of the bus and one or more cameras recording events within the bus, with an eventing system for crash detection, a video camera with preview, and a
15 geolocation tracker, integrated with a map database includes but is not limited to the following advantages: (a) comprehensive monitoring for how events outside of the bus impact events inside the bus, including but not limited to bus collisions; (b) the video camera would trigger from a collision and would have several seconds of preview buffer enabling it to record several seconds
20 prior to the collision; (c) the crash detector event could also trigger a collision message to a central location along with geolocation data indicating where the collision occurred; (d) the information could be archived to a central office via cellular upload or Wi-Fi; and (e) the central office could collect media from cameras not on the bus to provide different angles of the accident.

[00223] The descriptions of the above scenarios are not intended to be an exhaustive list of uses of the present embodiments and are only some of the many possible applications made possible.

Conclusion

5 **[00224]** In compliance with the statute, the subject matter of this application has been described in a language more or less specific as to structure and method features. It is to be understood, however, that the embodiments are not limited to the specific features described, since the disclosure herein comprise exemplary forms of putting the present
10 embodiments into effect. The present embodiments are, therefore, claimed in any of its forms or modifications within the proper scope of the appended claims appropriately interpreted in accordance with the doctrine of equivalents and other applicable judicial doctrines.

We claim:

1. A method, comprising:
 - generating at least one identifier for at least one data asset (410);
 - 5 associating the at least one data asset (410) with other data assets based on the at least one identifier, wherein the other data assets are associated with correlating metadata;
 - associating the correlating metadata with the at least one data asset (410);
 - 10 storing the correlating metadata (150) of the at least one data asset;
 - correlating the at least one data asset and the other data assets based on at least one of the stored correlating metadata (210);
 - retrieving at least a portion of the at least one data asset correlated with the other data assets (210); and
 - 15 generating a combination presentation of the retrieved portions (220).
2. The method of claim 1, wherein the associating of the at least one data asset and the other data assets based on the at least one identifier is performed within an organized or unorganized network group (130, 200).
- 20 3. The method of claim 1, wherein the generating of the at least one identifier (410) is performed automatically, and the associating of the at least one data asset and the other data assets is based on the at least one identifier automatically in real-time.

4. The method of claim 1, wherein the correlating metadata includes both metadata acquired upon a media capture occurrence (420) as well as metadata associated after the media capture occurrence (471).
- 5 5. The method of claim 1, wherein the correlating of the at least one data asset and the other data assets is based on at least some of the stored correlating metadata results (150) and the correlating is not synchronized according to time of media capture.
- 10 6. The method of claim 1, wherein the retrieving of at least a portion of the at least one data asset correlated with the other data assets is based on at least a portion of the stored correlating metadata (150).
7. The method of claim 1, further comprising:
- 15 rendering the generated combination presentation (220); and
interactively selecting a portion of the generated combination presentation to view during the rendering (473).
8. A portable system to capture media, comprising:
- 20 a digital camera (511) to capture media as a digital data asset;
a removable digital storage media to store the digital data asset in the form of a persistent file; and
a software metadata correlation system (550) to associate correlating metadata with an arbitrary portion of the digital data asset.

9. The system of claim 8, further comprising:
a data receiver (520) to receive control data;
a data transmitter (520) to transmit acknowledgement data and file data from the system; and
- 5 a network connection over the data transmitter and the data receiver to transmit the persistent file along with the associated correlating metadata based at least on part of the control data.
10. The system of claim 8, further comprising:
10 a preview memory buffer to capture media;
a commit mechanism to commit at least some of the captured media in the preview memory buffer prior to time of triggering into a digital data asset (786); and
storing the digital data asset in the storage media.
- 15
11. The system of claim 10, further comprising:
an eventing system (751) to trigger the commit mechanism.
12. The system of claim 11, further comprising:
20 an RFID reader (720) to trigger notifications (730B) upon being proximate to an RFID;
and wherein the eventing system (751) is to further receive notifications from the RFID reader and trigger the commit mechanism.

13. The system of claim 8, wherein the removable storage media is located in a secure location remote from the camera.

14. The system of claim 8, wherein at least the removable storage media
5 portion of the system is located in a tamper proof container accessible upon proper authorization.

15. The system of claim 8, further comprising:
a codec (531) to preprocess the data asset according to a
10 predetermined file format prior to storage on the removable storage media.

16. The system of claim 8, further comprising:
a file system (782) to apply predetermined rules to store and delete
files on the removable storage media.

15

17. The system of claim 8, further comprising:
a battery (561) to power the system;
a inductance charging system (562) comprising:
a memory to store data relating to receiving inductive energy;
20 a processor to process the stored data;
a coil to receive inductive energy;
a power supply, coupled to the processor, to convert the
received inductive energy into direct current and to supply the direct
current to the battery.

25

18. The system of claim 8, further comprising:

a transceiver (520) capable of receiving and transmitting messages compliant with a short message service (SMS) protocol;

a first software module (720) to monitor the transceiver for an incoming message, the incoming message comprising at least one instruction to control at least media capture by the digital camera;

a second software module (730B, 751) to interpret the at least one instruction in the incoming message and to trigger at least one software event responsive to the interpreted at least one instruction; and

a third software module (785) to perform the interpreted at least one instruction.

19. A computer readable medium storing computer readable instructions that, when executed, cause one or more processors to:

receive a data asset and an associated identifier (121, 122, 123);

associate the data asset with other data assets that are associated with correlating metadata, based on the identifier (410);

associate the correlating metadata with the data asset (150);

store the correlating metadata of the data asset (150);

correlate the data asset with other data assets based on at least some of the stored correlating metadata (150);

retrieve a portion of the data correlated with the other data assets (210);

generate a combination presentation of the retrieved portions (220);

and

present the generated combination presentation upon demand (220).

20. The computer readable medium as recited in claim 19, wherein the computer readable instructions further instruct the one or more processors to:

5 store data assets (150);

retrieve at least some of the stored data assets based on at least some of the correlating metadata (210); and

present the retrieved data assets with the generated combination presentation (220).

10

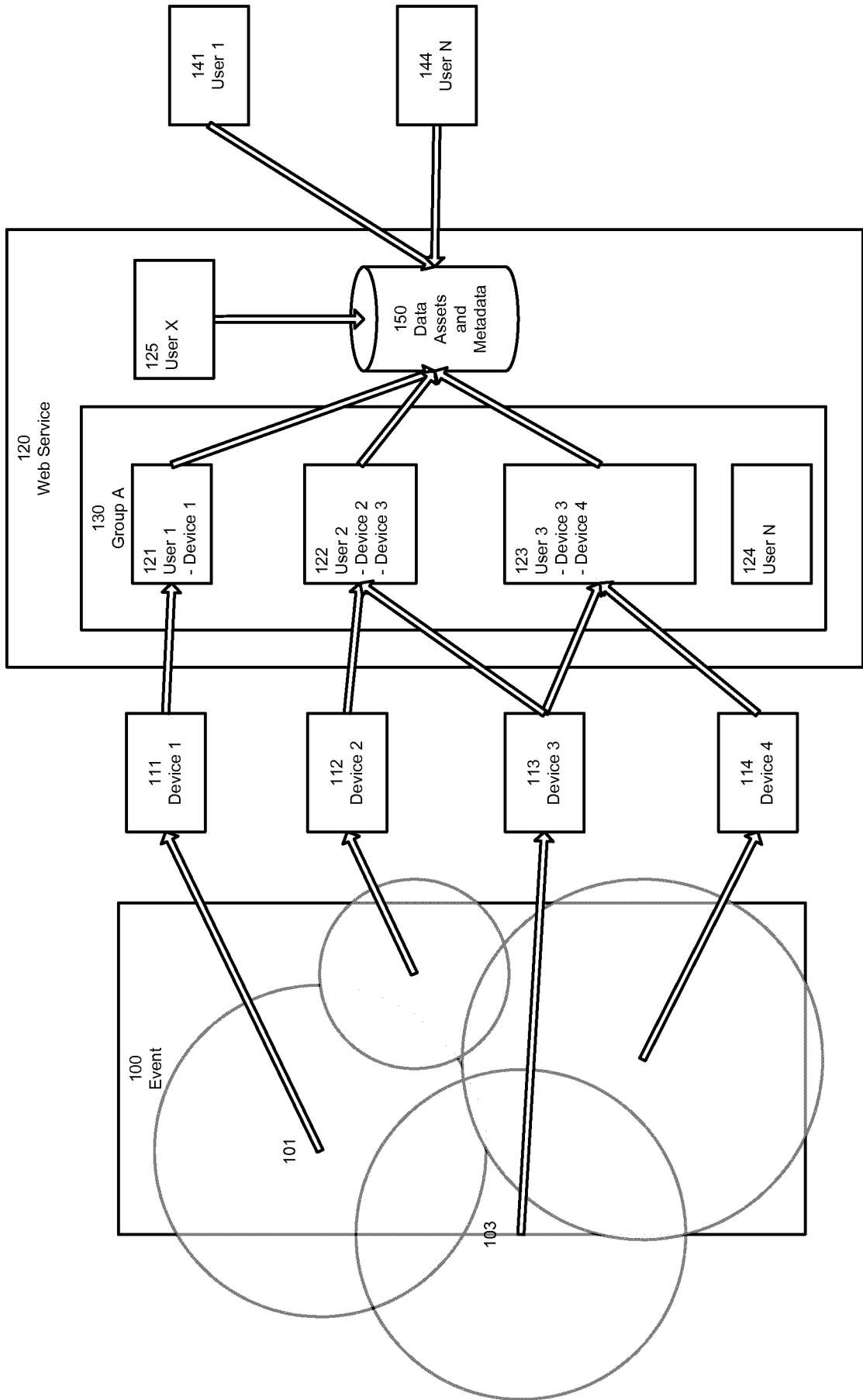

Figure 1

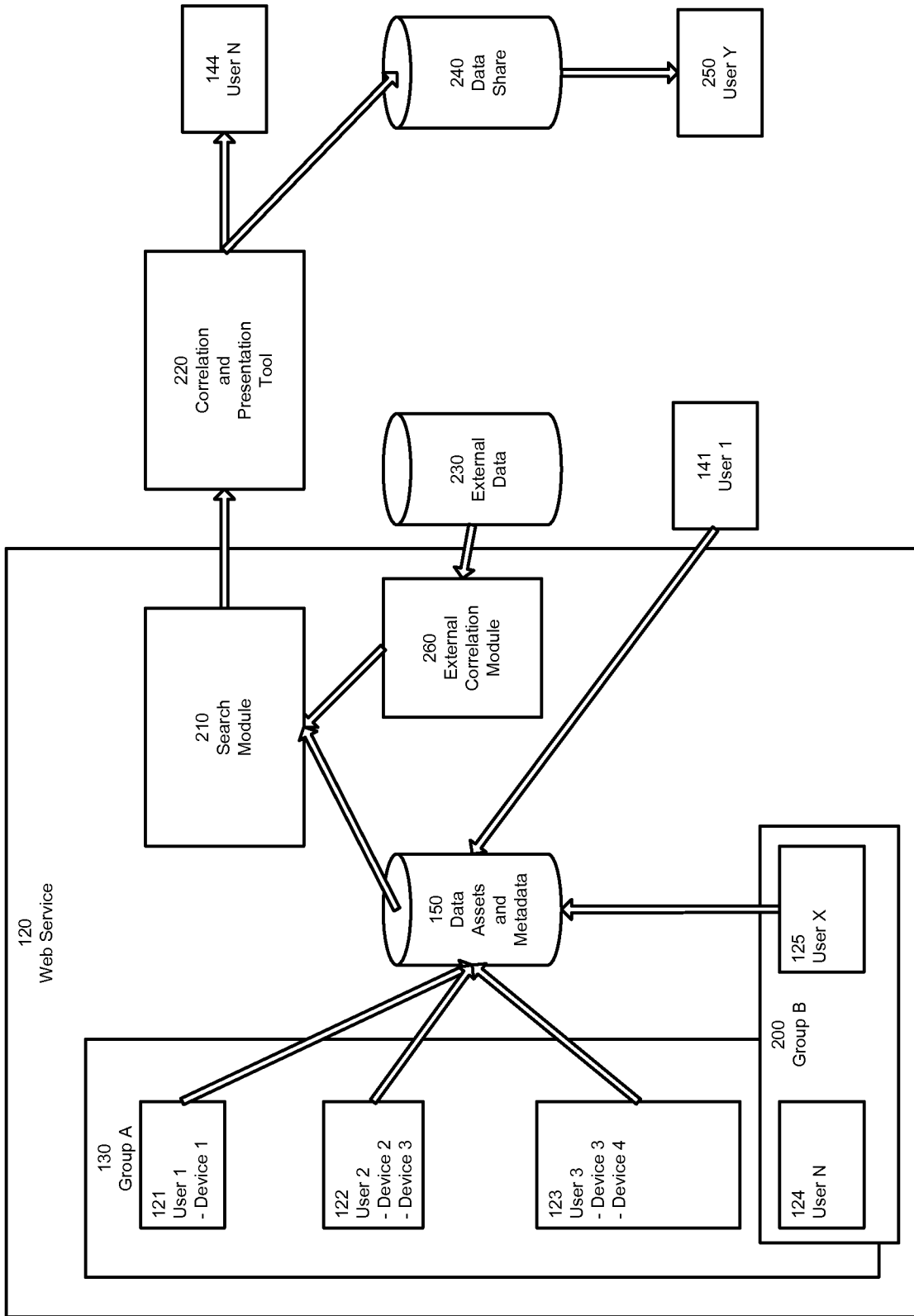

Figure 2

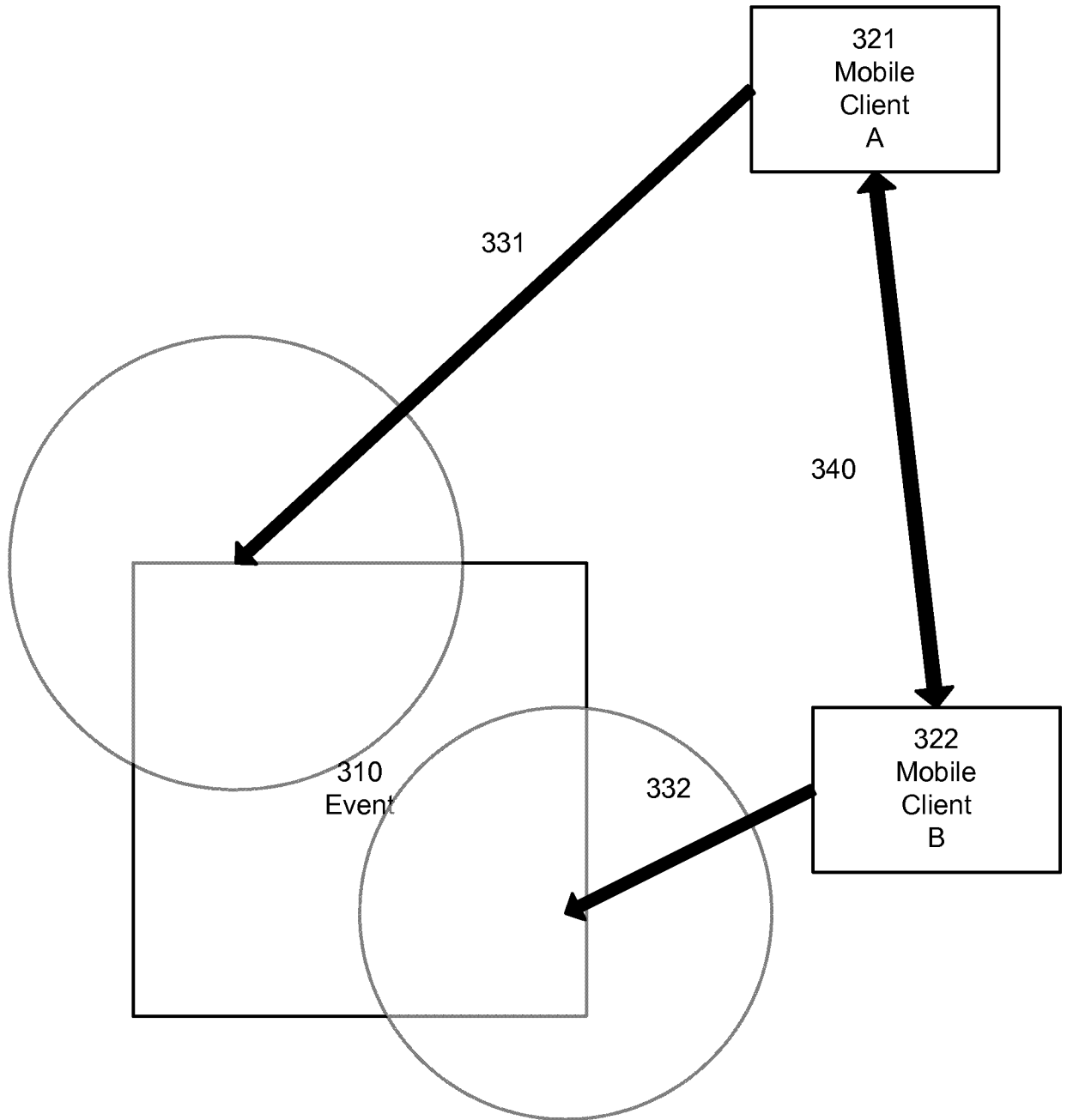

Figure 3

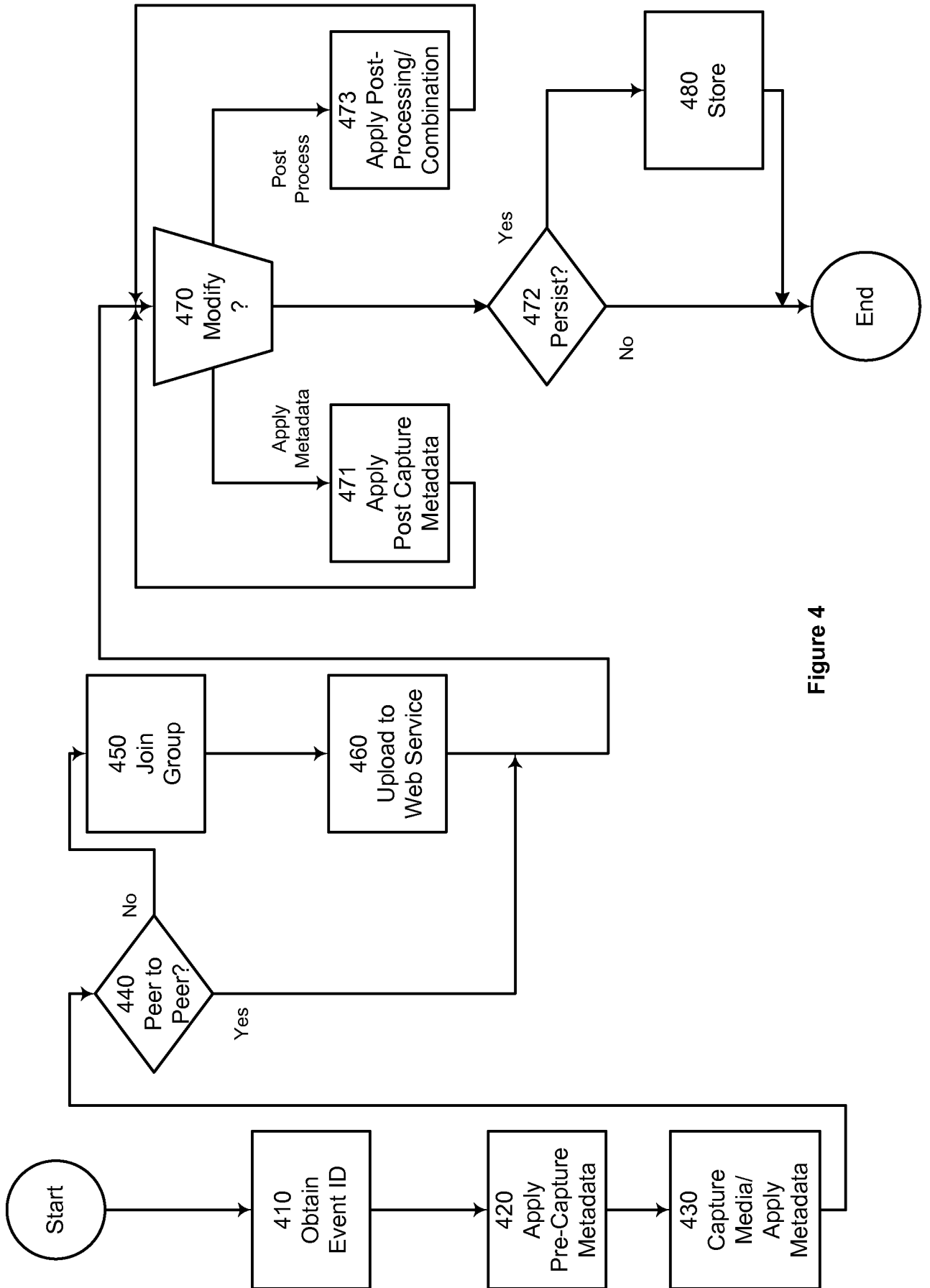

Figure 4

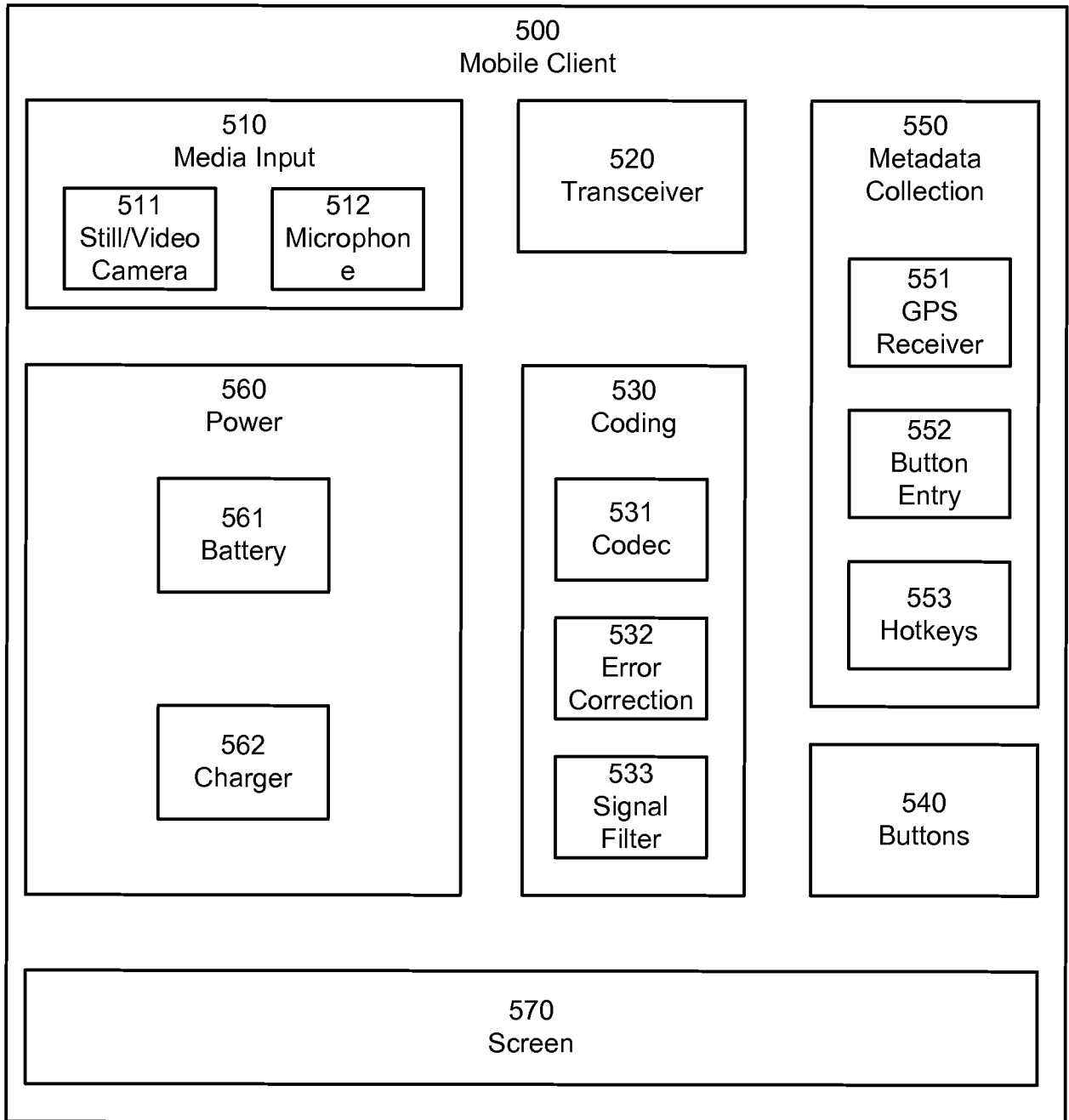

Figure 5

6/10

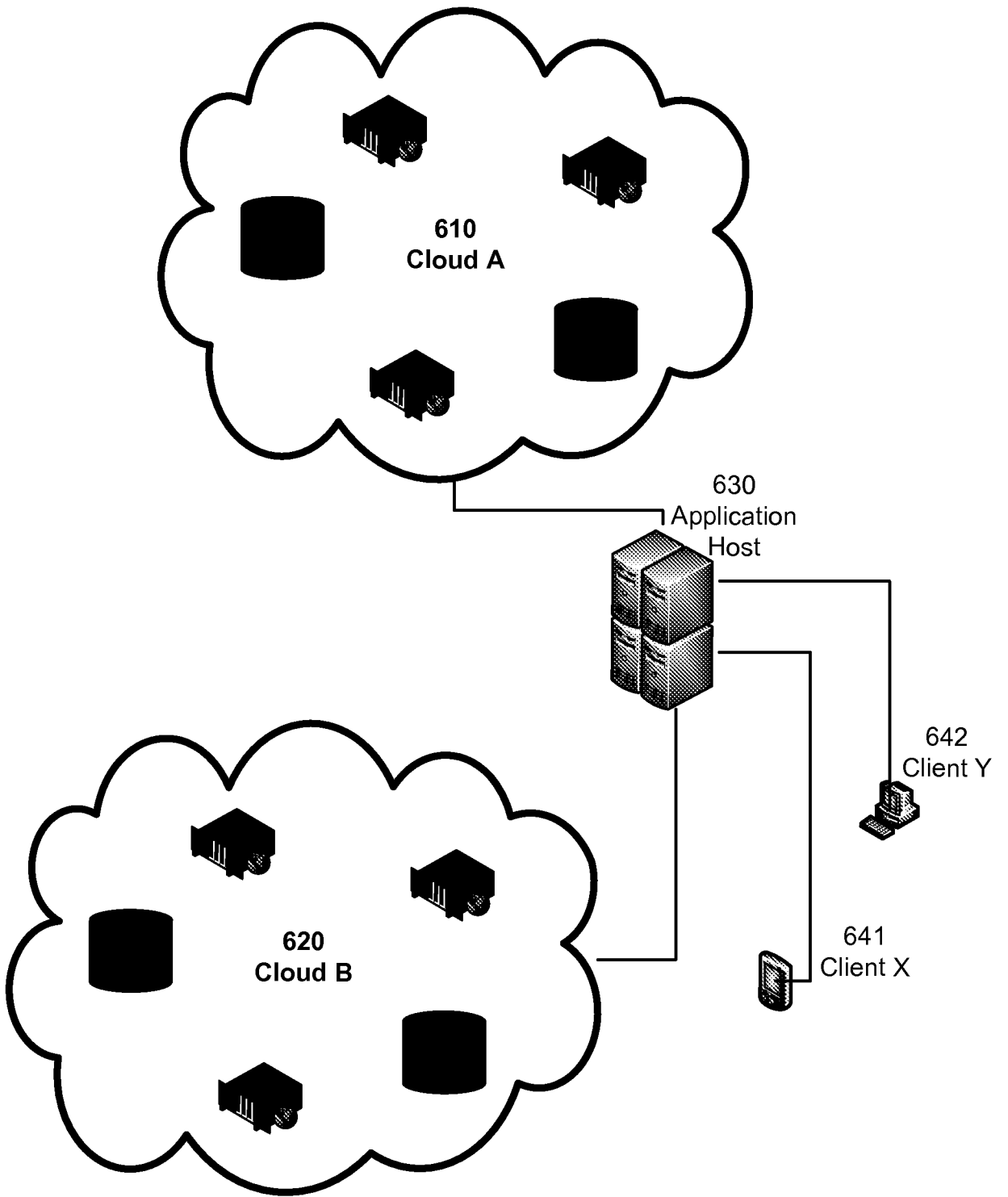

Figure 6

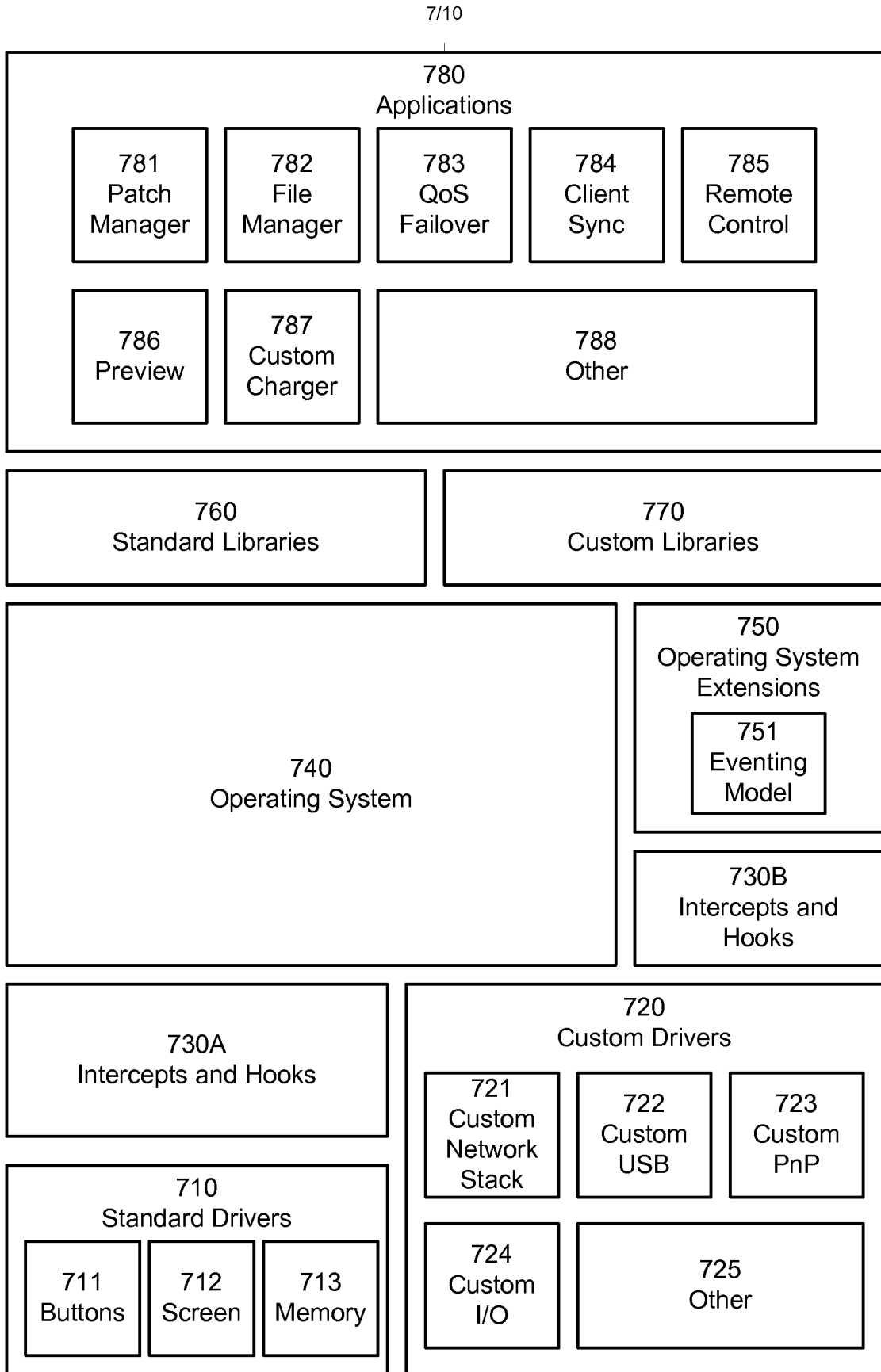

Figure 7

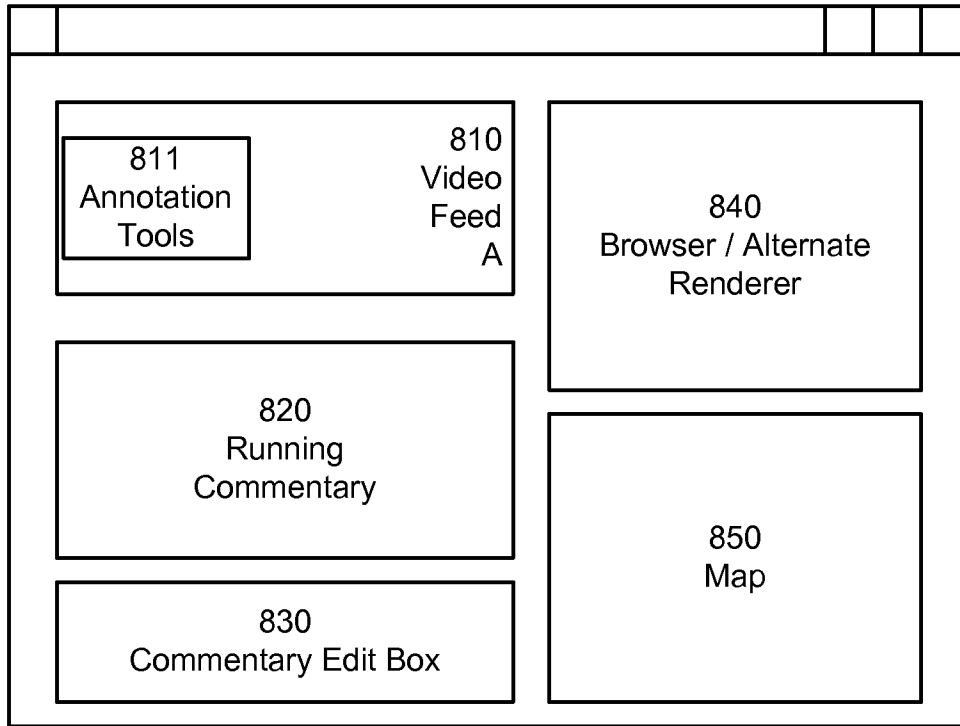

Figure 8A

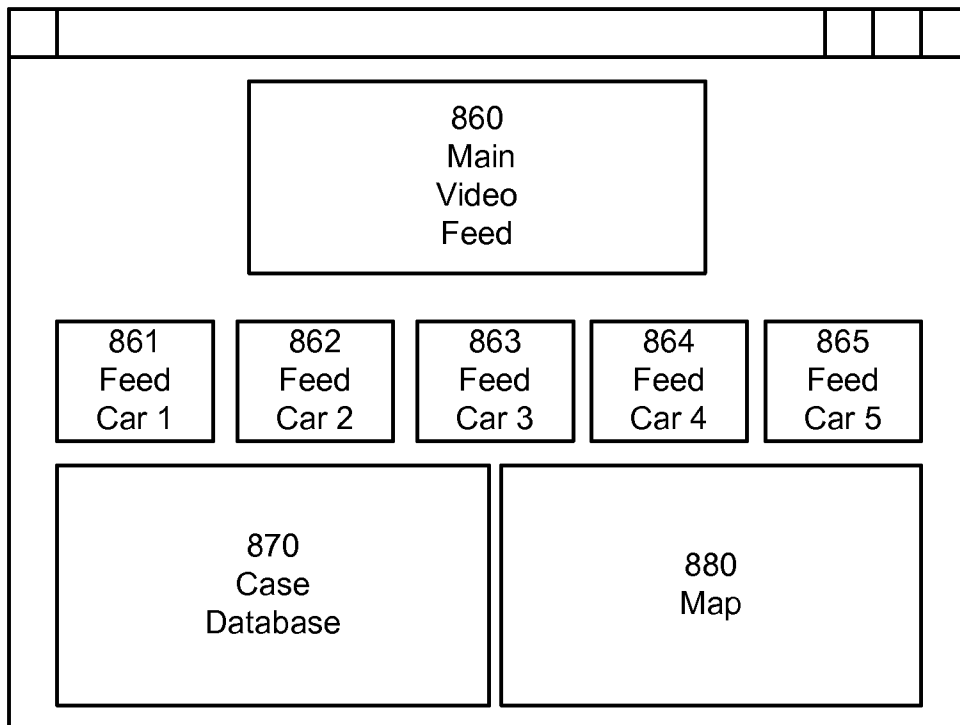

Figure 8B

9/10

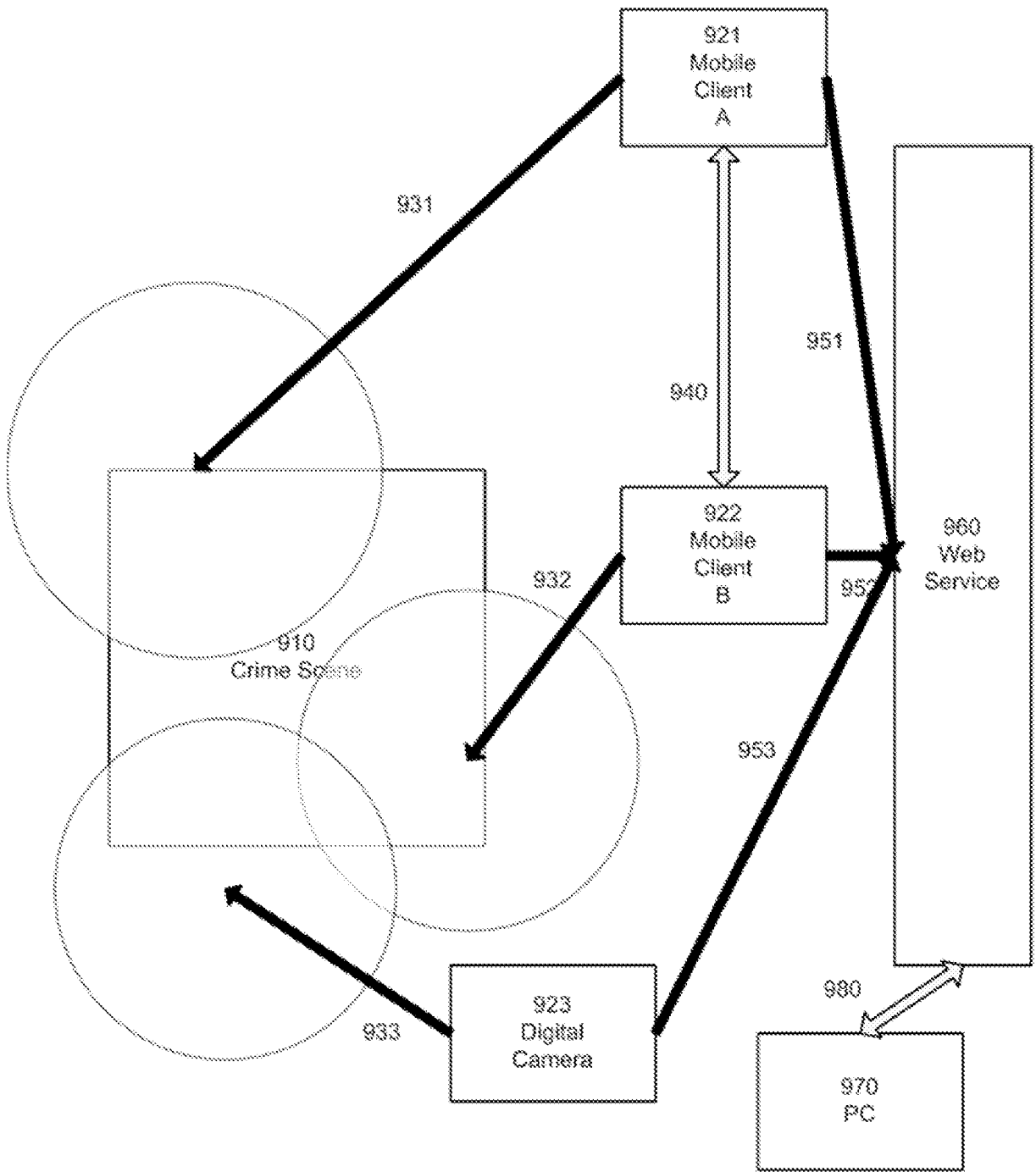

Figure 9

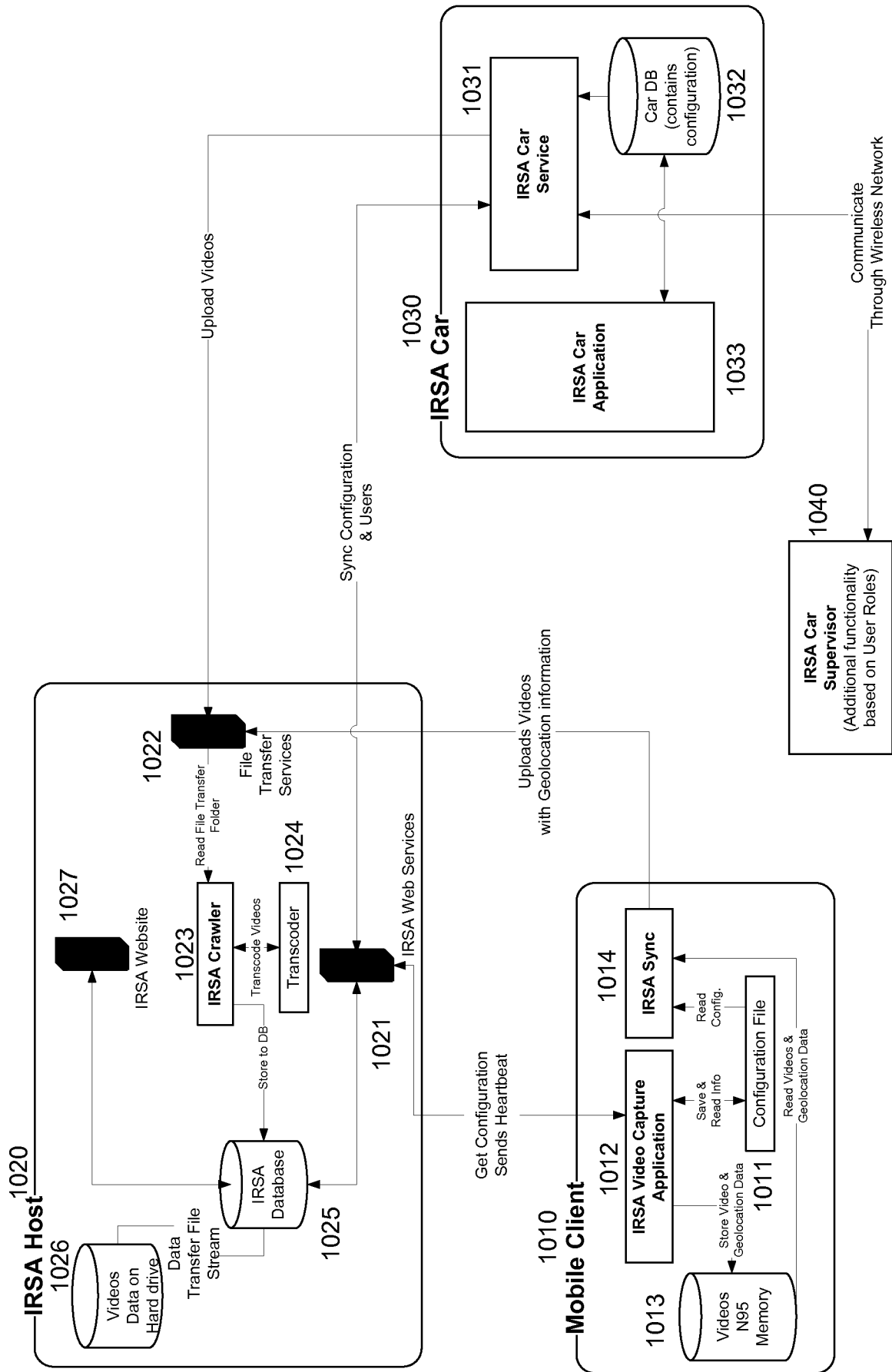

Figure 10

INTERNATIONAL SEARCH REPORT

International application No.
PCT/US2009/068776**A. CLASSIFICATION OF SUBJECT MATTER****H04L 12/28(2006.01)i**

According to International Patent Classification (IPC) or to both national classification and IPC

B. FIELDS SEARCHED

Minimum documentation searched (classification system followed by classification symbols)

IPC : H04B, H04L, H04W

Documentation searched other than minimum documentation to the extent that such documents are included in the fields searched
KOREAN UTILITY MODELS AND APPLICATIONS FOR UTILITY MODELS SINCE 1975Electronic data base consulted during the international search (name of data base and, where practicable, search terms used)
eKOMPASS, DELPHION, ESPACENET & Keywords : digital camera, identifier, data asset, correlating metadata, retrieved portions, combination presentation, digital storage, metadata correlation system and similar terms.**C. DOCUMENTS CONSIDERED TO BE RELEVANT**

Category*	Citation of document, with indication, where appropriate, of the relevant passages	Relevant to claim No.
X	EP 1550968 A1 (NOKIA CORPORATION) 06 July 2005 See whole documents.	8
A	US 2008-0250328 A1 (HANNU KONTTINEN) 09 October 2008 See abstract, pages 1-2 and claims 1-3.	1-20
A	US 2008-0187181 A1 (WILLIAM D. MEADOW et al.) 07 August 2008 See abstract, claims 1-3 and figure 1.	1-20
A	US 2007-0255618 A1 (JASON R. MEEBERBERGEN et al.) 01 November 2007 See abstract, pages 1-2 and claim 1.	1-20

 Further documents are listed in the continuation of Box C. See patent family annex.

* Special categories of cited documents:

"A" document defining the general state of the art which is not considered to be of particular relevance

"E" earlier application or patent but published on or after the international filing date

"L" document which may throw doubts on priority claim(s) or which is cited to establish the publication date of citation or other special reason (as specified)

"O" document referring to an oral disclosure, use, exhibition or other means

"P" document published prior to the international filing date but later than the priority date claimed

"T" later document published after the international filing date or priority date and not in conflict with the application but cited to understand the principle or theory underlying the invention

"X" document of particular relevance; the claimed invention cannot be considered novel or cannot be considered to involve an inventive step when the document is taken alone

"Y" document of particular relevance; the claimed invention cannot be considered to involve an inventive step when the document is combined with one or more other such documents, such combination being obvious to a person skilled in the art

"&" document member of the same patent family

Date of the actual completion of the international search

27 JULY 2010 (27.07.2010)

Date of mailing of the international search report

27 JULY 2010 (27.07.2010)

Name and mailing address of the ISA/KR

Korean Intellectual Property Office
Government Complex-Daejeon, 139 Seonsa-ro, Seo-
gu, Daejeon 302-701, Republic of Korea

Facsimile No. 82-42-472-7140

Authorized officer

KIM Dae Sung

Telephone No. 82-42-481-8237



INTERNATIONAL SEARCH REPORT

Information on patent family members

International application No.

PCT/US2009/068776

Patent document cited in search report	Publication date	Patent family member(s)	Publication date
EP 1550968 A1	06.07.2005	KR 20050069918 A KR 10-0651048 B1 US 2009-276531 A1 US 07685134 B2 US 2005-0165795 A1	05.07.2005 29.11.2006 05.11.2009 23.03.2010 28.07.2005
US 2008-0250328 A1	09.10.2008	CN 101652776 A EP 2130150 A1 KR 10-2010-0004108 A WO 2008-120111 A1	17.02.2010 09.12.2009 12.01.2010 09.10.2008
US 2008-0187181 A1	07.08.2008	NONE	
US 2007-0255618 A1	01.11.2007	EP 2021911 A2 WO 2007-127054 A3 WO 2007-127054 A2 WO 2007-127054 A3	11.02.2009 21.12.2007 08.11.2007 08.11.2007