



US 20140046508A1

(19) **United States**
(12) **Patent Application Publication**
Himmelstein

(10) **Pub. No.: US 2014/0046508 A1**
(43) **Pub. Date: Feb. 13, 2014**

(54) **PROVIDING VEHICLE SERVICES AND CONTROL OVER A CELLULAR DATA NETWORK**

- (71) Applicant: **Seong Sang Investments LLC**,
Wilmington, DE (US)
- (72) Inventor: **Richard B. Himmelstein**, Kure Beach,
NC (US)
- (73) Assignee: **Seong Sang Investments LLC**,
Wilmington, DE (US)

continuation of application No. 12/018,588, filed on Jan. 23, 2008, now Pat. No. 7,536,189, which is a continuation of application No. 11/524,858, filed on Sep. 20, 2006, now Pat. No. 7,450,955, which is a continuation of application No. 10/705,674, filed on Nov. 10, 2003, now Pat. No. 7,123,926, which is a continuation of application No. 09/659,074, filed on Sep. 11, 2000, now Pat. No. 6,647,270.

(60) Provisional application No. 60/153,424, filed on Sep. 10, 1999.

- (21) Appl. No.: **14/053,237**
- (22) Filed: **Oct. 14, 2013**

Related U.S. Application Data

- (63) Continuation of application No. 12/870,219, filed on Aug. 27, 2010, now Pat. No. 8,565,734, which is a continuation of application No. 12/841,433, filed on Jul. 22, 2010, now Pat. No. 7,885,685, which is a continuation of application No. 12/546,645, filed on Aug. 24, 2009, now Pat. No. 7,783,304, which is a continuation of application No. 12/389,245, filed on Feb. 19, 2009, now Pat. No. 7,599,715, which is a

Publication Classification

- (51) **Int. Cl.**
H04W 4/00 (2006.01)
- (52) **U.S. Cl.**
CPC **H04W 4/00** (2013.01)
USPC **701/2**

(57) **ABSTRACT**

Providing vehicle services and control over a cellular data network is disclosed. Vehicle maintenance and operation information may be provided to a vehicle. An instruction to remotely control locks or a horn of the vehicle based on security levels and other criteria is also disclosed.

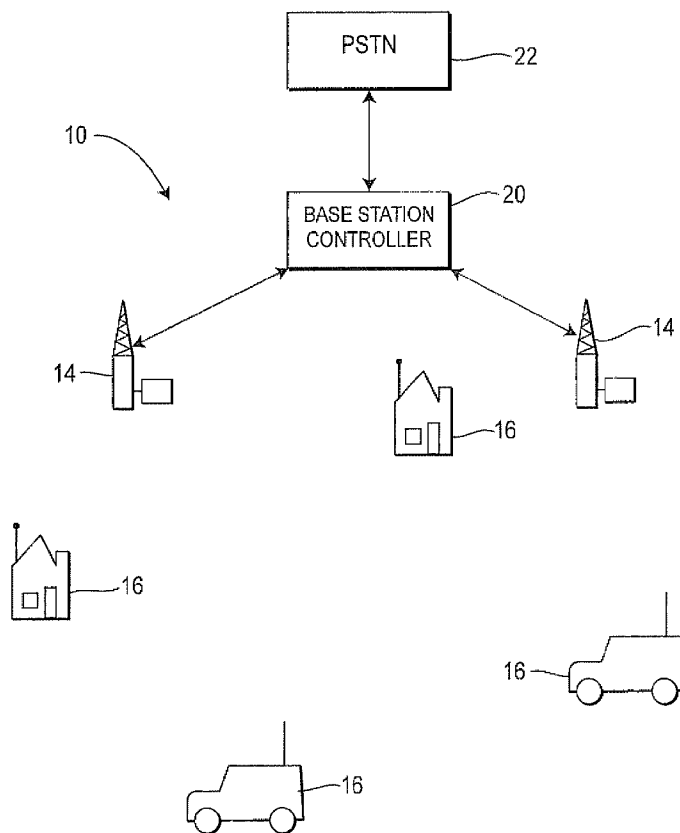

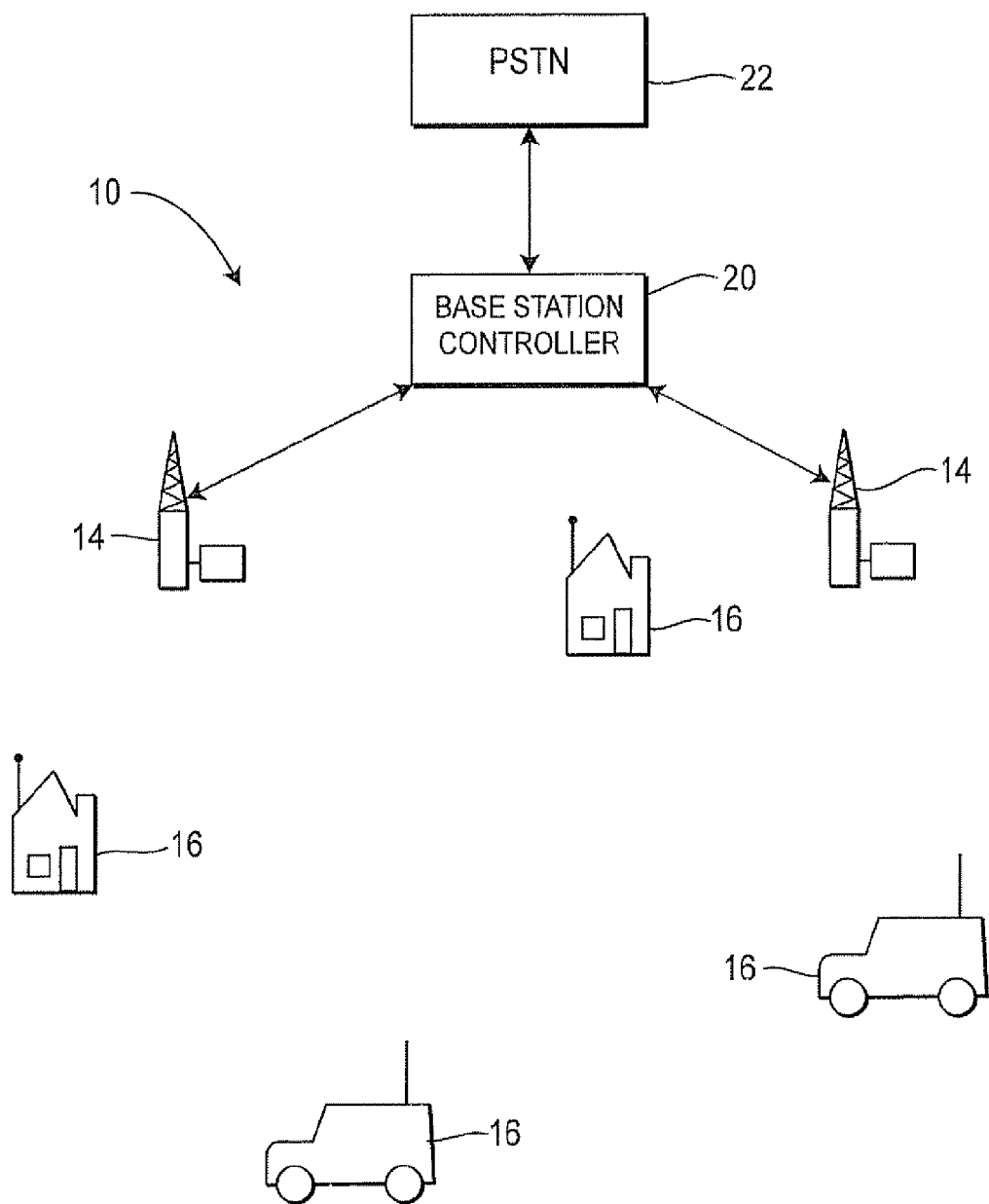

FIG. 1

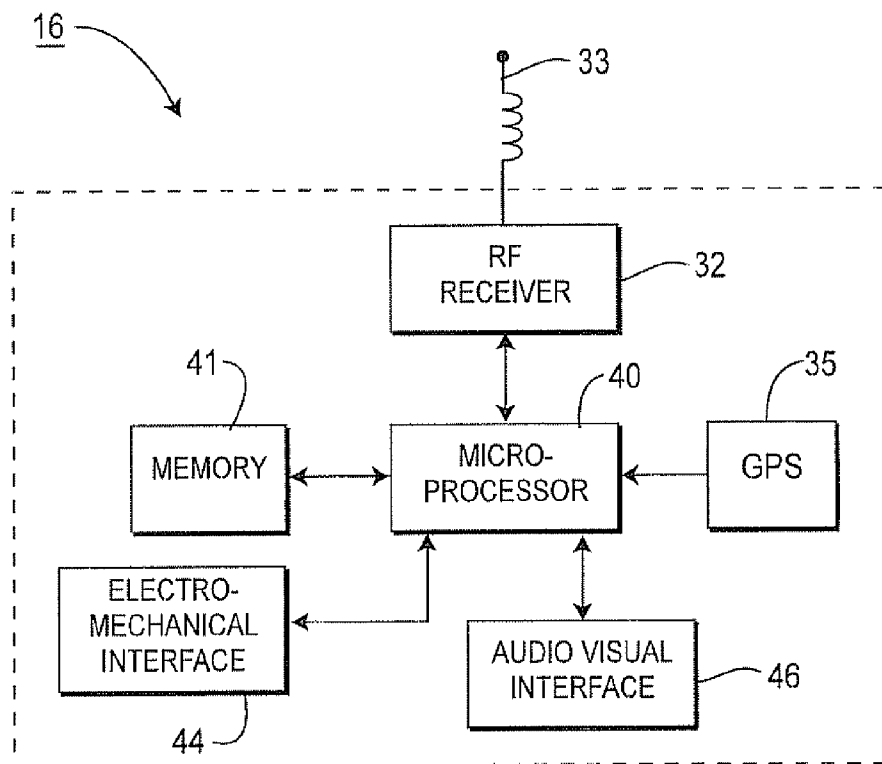

FIG. 2

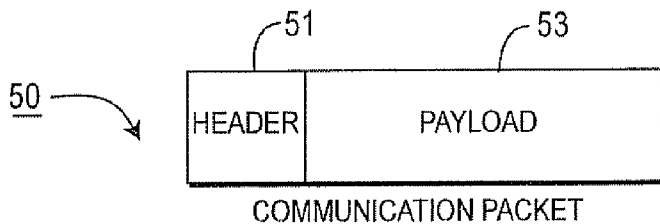

FIG. 3A

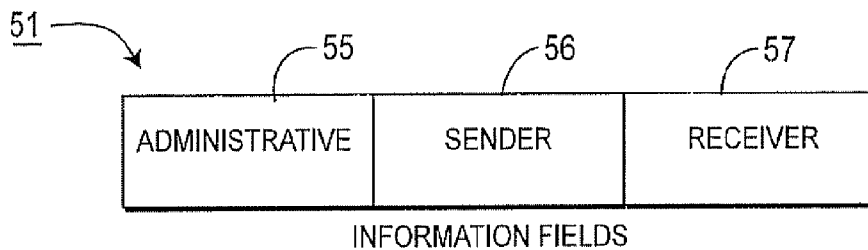
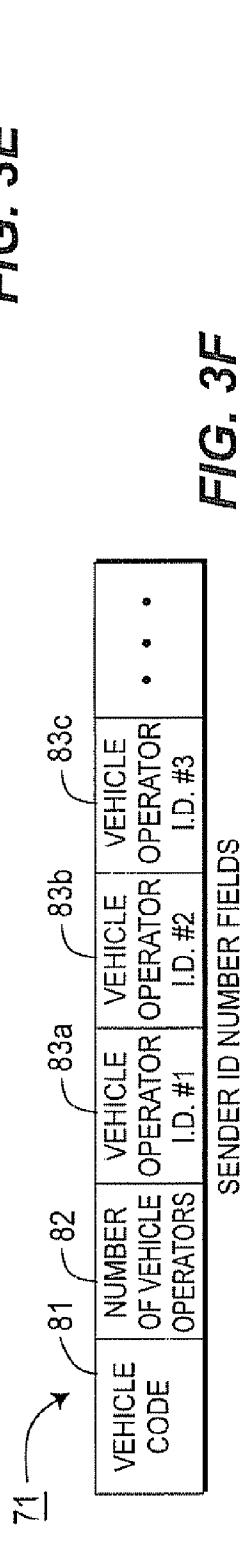
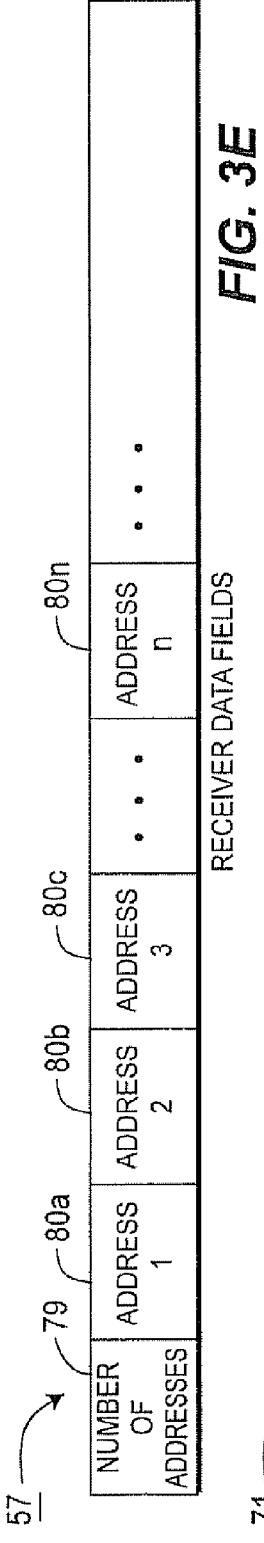
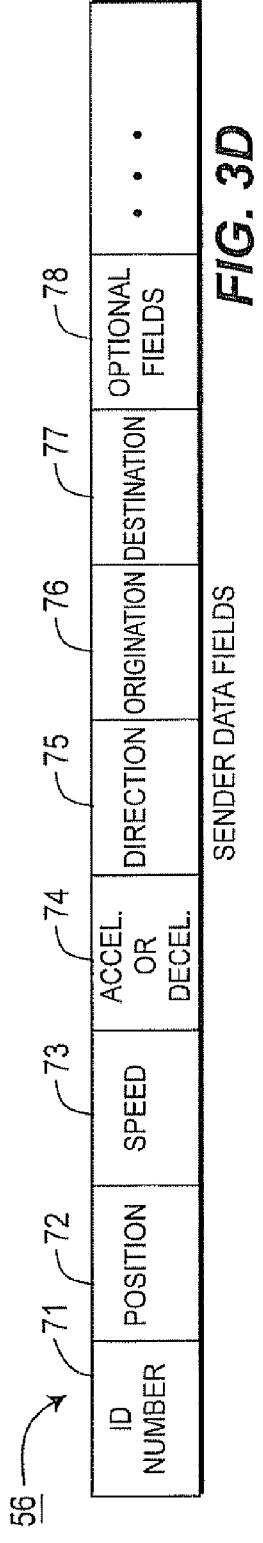
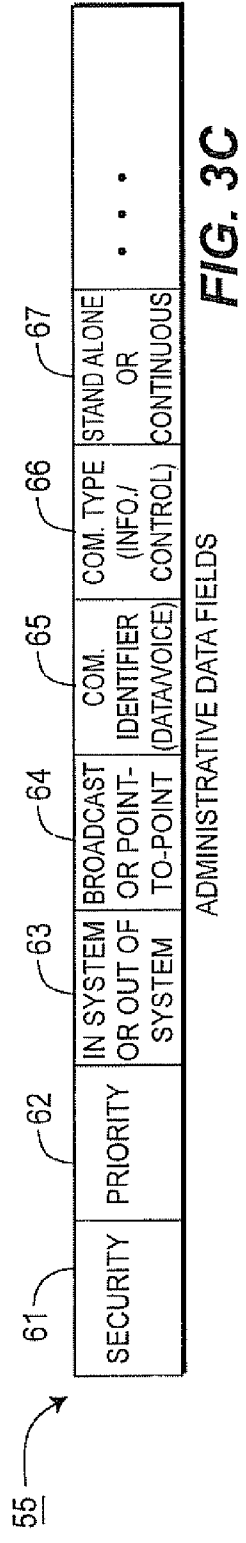

FIG. 3B



90

90a	90b	90c	90d	90e	90f
TIME	DATE	POSITION	SPEED	ACC./DECEL.	DIRECTION
08:50	09/01/2000	42°34,18'31	65	A	NNW

FIG. 4A

92

92a	92b	92c	92d	92e	92f	92g	92h	92i	92j	92k
TIME	DATE	INCOMING/ OUTGOING	ADDRESSES	PRIORITY	BROADCAST/ POINT-TO-POINT	IN/OUT OF SYSTEM	SECURITY	DATA/ VOICE	INFO/ CONTROL	CONTENTS
08:52	09/01/2000	I	432967185	4	B	I	5	V	I	TRAFFIC MESSAGE
12:08	09/01/2000	I	458341788	1	P	I	1	D	C	REDUCE SPEED CONTROL INSTRUCTION

FIG. 4B

105

105a	REGISTRATION	INSURANCE COMPANY	INSURANCE POLICY NUMBER	VEHICLE MAKE	VEHICLE MODEL	VEHICLE COLOR	OTHER ID INFO	VEHICLE MODEL YEAR	EZ PASS NUMBER	GARAGE PARKING ACCOUNT #	GARAGE DOOR ACCESS CODE	DRIVING RECORD	CREDIT CARD INFO

FIG. 4C

110

110a	TIME	DATE	ADDRESS	COLOR	MAKE	MODEL
						•••

FIG. 4D

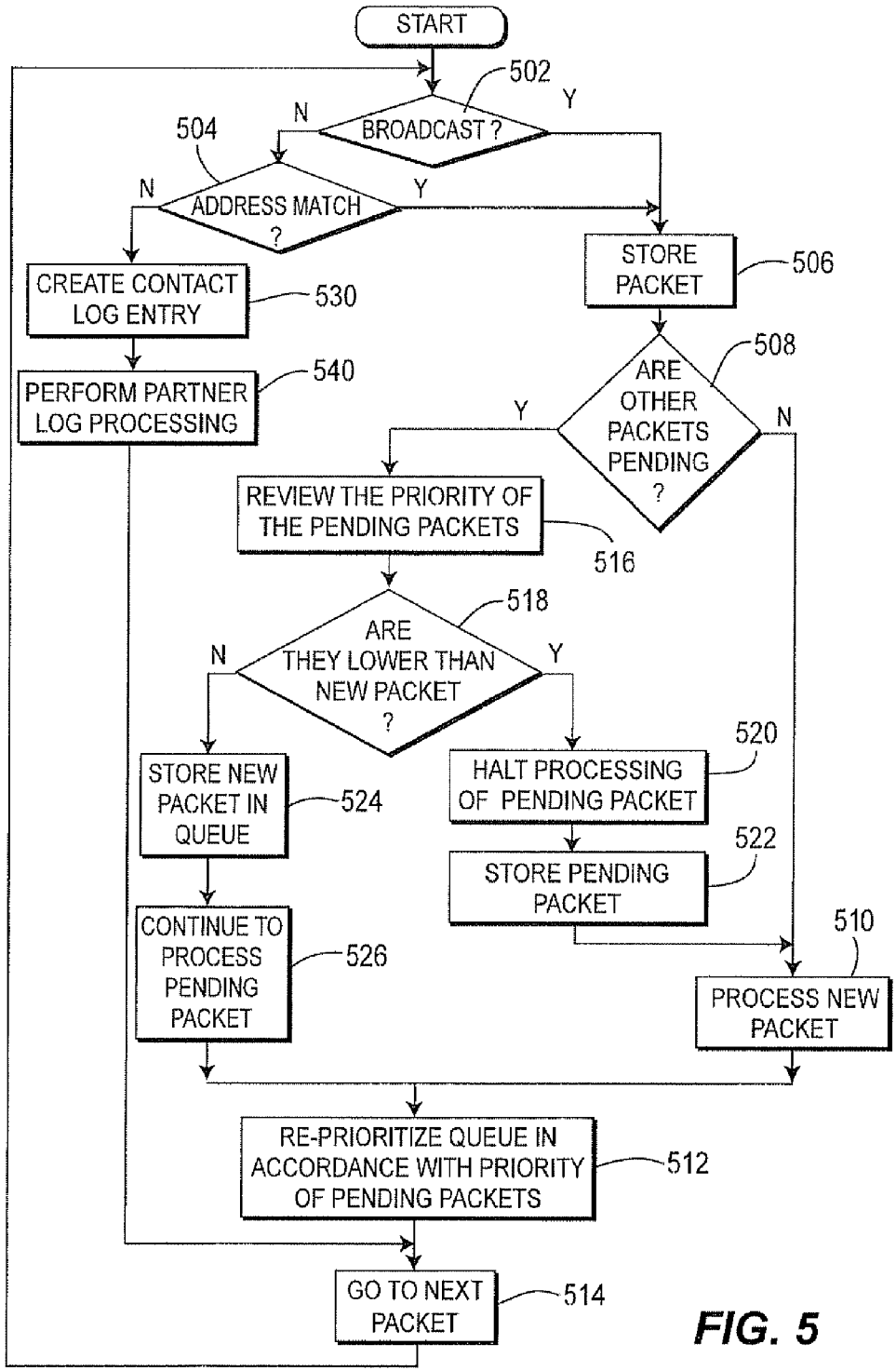

FIG. 5

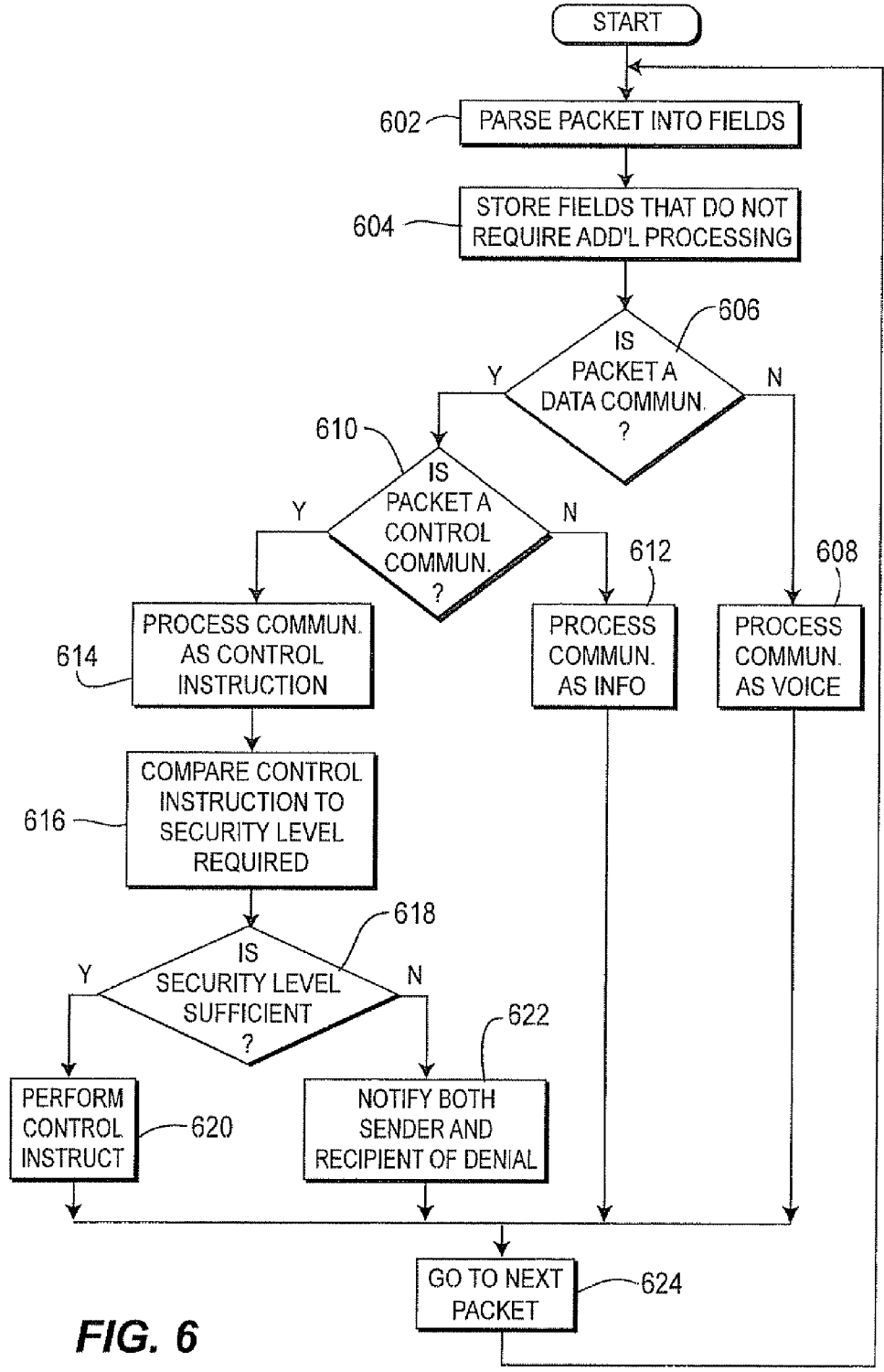

FIG. 6

PROVIDING VEHICLE SERVICES AND CONTROL OVER A CELLULAR DATA NETWORK

CROSS REFERENCE TO RELATED APPLICATION

[0001] This application is a continuation of U.S. patent application Ser. No. 12/870,219 filed Aug. 27, 2010, which is a continuation of U.S. patent application Ser. No. 12/841,433 filed Jul. 22, 2010, issued as U.S. Pat. No. 7,885,685 on Feb. 8, 2011, which is a continuation of U.S. patent application Ser. No. 12/546,645 filed Aug. 24, 2009, issued as U.S. Pat. No. 7,783,304 on Aug. 24, 2010, which is a continuation of U.S. patent application Ser. No. 12/389,245 filed Feb. 19, 2009, issued as U.S. Pat. No. 7,599,715 on Oct. 6, 2009, which is a continuation of U.S. patent application Ser. No. 12/018,588 filed Jan. 23, 2008, issued as U.S. Pat. No. 7,536,189 on May 19, 2009, which is a continuation of U.S. patent application Ser. No. 11/524,858 filed Sep. 20, 2006, issued as U.S. Pat. No. 7,450,955 on Nov. 11, 2008, which is a continuation of U.S. patent application Ser. No. 10/705,674 filed Nov. 10, 2003, issued as U.S. Pat. No. 7,123,926 on Oct. 17, 2006, which was a continuation of U.S. patent application Ser. No. 09/659,074 filed Sep. 11, 2000, issued as U.S. Pat. No. 6,647,270 on Nov. 11, 2003, which claims the benefit of U.S. Provisional Application No. 60/153,424 filed Sep. 10, 1999, all of which are hereby incorporated by reference herein as if fully set forth.

[0002] This application is related to U.S. patent application Ser. No. 10/705,065 filed on Nov. 10, 2003.

BACKGROUND

[0003] The present invention generally relates to communication systems. More particularly, the invention relates to a mobile communication system which allows mobile vehicles to communicate with neighboring vehicles and roadside communication networks.

[0004] Various communication systems have been used by automobile drivers to communicate with other vehicles while the vehicle is in motion. While many advances have been made in vehicle to vehicle communication, numerous disadvantages still remain in using conventional communication systems.

[0005] Conventional mobile communication systems include cellular telephones and CB or two-way radio. When using a cell phone as a means of mobile communication, there is no practical way of discovering whether a neighboring vehicle operator possesses a cell phone. Additionally, there is no process for determining the phone number of the targeted cell phone. Accordingly, the cell phone as a communication medium is severely limited.

[0006] CB radio is a widely broadcast public medium where mobile users may talk to other mobile or stationary users in their vicinity. However, since there is no ability to prevent others from listening, there is no privacy between mobile communicators.

[0007] Automobile accidents are one of the greatest causes of serious injury and fatalities in society. Accordingly, the development of improved control and warning systems to minimize personal and financial losses resulting from automobile accidents is of utmost importance. The limitations of present forms of communication are even more severe when

considering the extent to which a communication link can improve both the driving experience and the safety statistics of modern vehicles.

SUMMARY

[0008] The present invention provides a communication link among vehicles which eliminates these pitfalls. The system comprises a broadband RF transceiver with antenna, a position determining means, such as a GPS receiver, an audio-visual interface, an electro-mechanical interface and a microprocessor with associated memory. These components are incorporated into a mobile unit located within each vehicle.

[0009] The GPS receiver receives signals from GPS satellites and calculates the position of the vehicle. The microprocessor carries out overall control of the system. The memory includes identification information that is unique to each vehicle. In response to input from the GPS receiver, information received by the transceiver and instructions input by the vehicle operator via the audio-visual interface, the microprocessor determines the necessary subsequent actions.

[0010] The transmission from a vehicle may include information describing the status of the vehicle for use by the receiving vehicle. For example, the transmission may provide information regarding the speed, direction and position of the transmitting vehicle. This information is received and processed by the receiving vehicle to provide a visual or audible display of the position, direction and speed of the transmitting vehicle.

[0011] According to one aspect of the present invention, there is provided a communication system for transmitting information between a mobile unit within a vehicle traveling on a road and a fixed communication network installed on a roadside. The fixed communication network includes a base station having a transceiver for communicating with the vehicle by transmitting and receiving a plurality of communication packets. This communication can include payment instructions, security instructions and/or access codes which can be transmitted with or without intervention by the vehicle operator.

BRIEF DESCRIPTION OF THE DRAWING(S)

[0012] FIG. 1 shows a vehicle communication system embodying the present invention.

[0013] FIG. 2 is a block diagram showing a vehicletalk mobile unit in accordance with the preferred embodiment.

[0014] FIG. 3A is a diagram illustrating the contents of a communication packet transmitted by the vehicletalk mobile unit.

[0015] FIG. 3B illustrates the header of the communication packet.

[0016] FIG. 3C illustrates the information fields of the header's transmission administration.

[0017] FIG. 3D illustrates the information fields of the header's sender portion.

[0018] FIG. 3E illustrates the information fields of the header's receiver portion.

[0019] FIG. 3F illustrates the sub fields contained in the identification number field.

[0020] FIG. 4A illustrates the memory of a typical vehicletalk mobile unit.

[0021] FIG. 4B is a diagram of a vehicle communication log.

[0022] FIG. 4C is a diagram of a vehicle user log.

[0023] FIG. 4D is a diagram of a vehicle contact log.

[0024] FIG. 5 is a flow diagram of the procedure utilized by the microprocessor upon receipt of a communication packet.

[0025] FIG. 6 is a flow diagram of the procedure for processing communication packets.

DETAILED DESCRIPTION OF THE PREFERRED EMBODIMENT(S)

[0026] The preferred embodiment will be described with reference to the drawing figures where identical numerals represent similar elements throughout.

[0027] A vehicle communication system embodying the present invention is shown in FIG. 1. The vehicle communication system 10 generally comprises one or more base stations 14, each of which is in wireless communication with a plurality of vehicletalk remote units 16. Although the remote units 16 may be fixed or mobile, they will be referred to hereinafter for simplicity as vehicletalk mobile units 16. Each mobile unit 16 can communicate with another mobile unit 16, the closest base station 14 or the base station 14 which provides the strongest communication signal. The base stations 14 communicate with a base station controller 20, which coordinates communications among base stations 14 and vehicletalk mobile units 16. The communication system 10 may be connected to a public switched telephone network (PSTN) 22, wherein the base station controller 20 also coordinates communications between the base stations 14 and the PSTN 22. Preferably, each base station 14 communicates with the base station controller 20 over a wireless link, although a land line may also be provided. A land line is particularly applicable when a base station 14 is in close proximity to the base station controller 20. The fixed vehicletalk remote units 16 may also communicate with a base station 14 over a land line.

[0028] The base station controller 20 performs several functions. Primarily, the base station controller 20 provides all of the operations, administrative and maintenance (OA&M) signaling associated with establishing and maintaining all of the wireless communications between the mobile units 16, the base stations 14 and the base station controller 20. The base station controller 20 can provide the routing of all communications between mobile units 16, and between the mobile units 16 and the PSTN 22. The base station controller 20 also provides an interface between the mobile units 16 and the PSTN 22. This interface includes multiplexing and demultiplexing of the communication signals that enter and leave the system 10 via the base station controller 20. Although the vehicle communication system 10 is shown employing antennas to transmit RF signals, one skilled in the art should recognize that communications may be accomplished via microwave or satellite uplinks. Additionally, the functions of the base station controller 20 may be combined with a base station 14 to form a "master base station".

[0029] A preferred embodiment of the vehicletalk mobile unit 16 is shown in FIG. 2. Each mobile unit includes an RF transceiver 32 with an antenna 33 capable of transmitting and receiving a plurality of RF signals, a GPS receiver 35, a microprocessor 40 with associated memory 41, an interface to the vehicle's electro-mechanical systems 44 and an audio-visual interface 46.

[0030] The RF transceiver 32 transmits and receives RF signals at a plurality of RF frequencies to one or more

vehicles which include a vehicletalk mobile unit 16. Received signals are downloaded to baseband and forwarded to the microprocessor for further processing. Transmitted signals are forwarded from the microprocessor 40 to the RF transceiver 32 for upconversion and transmission over one of the plurality of RF frequencies. The vehicle communication system 10 also provides for the option of transmitting a communication over currently licensed radio station channels, for example 105.9 FM. This can permit a vehicletalk operator to broadcast to non-vehicletalk operators. It also can provide a "scanning channel", such that non-vehicletalk operators can listen to broadcast vehicletalk communications.

[0031] The GPS receiver 35 is configured to receive signals from GPS satellites and compute the position of the mobile unit 16. There are many commercially available GPS receivers 35 that can perform such a function. GPS readings which are provided to the microprocessor 40 permit the microprocessor 40 to accurately calculate the speed, direction and acceleration or deceleration rate of the vehicle.

[0032] The microprocessor 40 provides central control of the vehicletalk mobile unit 16. As will be explained in greater detail hereinafter, the microprocessor 40 also performs packet handling including packet assembling for outgoing communication packets 50 and packet disassembling for incoming communication packets 50 received from the RF transceiver 32. Communication packets 50 received by the microprocessor 40 are stored in memory 41. The memory 41 is also used to store identification information that is unique to each vehicle and/or vehicle operator. For example, license and registration for each vehicle can be read if positioned with a bar code or magnetic strip in a specific location of the vehicle. Optionally, the system may have a card reader where the operator must place their card prior to the vehicle starting. This card can be a license with a magnetic strip or can be a smartcard that may identify the driver and the vehicle. This unique information regarding the vehicle may also include the position of the vehicle, speed of the vehicle and rate of acceleration or deceleration as calculated by data obtained from the GPS receiver 35.

[0033] The audio-visual interface (AVI) 46 preferably comprises a microphone, speakers and graphic display along with alphanumeric and directional keypads. However, those of skill in the art should realize that the AVI 46 may encompass other input devices which are known, such as a voice activated input unit, an IR remote control, a full keyboard or any other type of electronic or manual data input means. Additionally, the output portion of the AVI 46 may comprise any type of output means such as a stereo system or a heads-up display.

[0034] The electro-mechanical interface 44 provides an electrical coupling to the electro-mechanical systems of the vehicle over which the vehicletalk mobile unit 16 has control. These systems may include the radio, lights, horn, windows, locks, steering, breaking and any other electro-mechanical systems of the vehicle.

[0035] Communications between vehicletalk mobile units 16 using the vehicle communication system 10 are accomplished through a stream of transmitted communication packets 50. As shown in FIG. 3A, each communication packet 50 comprises a header 51 and a payload 53. The header 51 comprises a plurality of predefined information fields which provide information regarding the particular communication, the sender which originated the communication and the receiver to which the communication is destined. It should be

recognized that a voice or data communication may be segmented or “packetized” and transmitted using a plurality of packets **50**. The present invention is not restricted to transmitting a communication having a predefined length. Accordingly, the payload **53** may comprise only a portion of the communication that is sent between mobile units **16**, and a single communication may be sent using a plurality of packets **50**. Communications may comprise data transmissions, such as uploads from, or downloads to, the mobile unit **16**; or may comprise voice communications.

[0036] Referring to FIG. 3B, the header **51** comprises a plurality of information fields which can be generally categorized by three different functional groups: 1) transmission administrative information **55**; 2) sender information **56**; and 3) receiver information **57**. These fields will be explained in greater detail hereinafter.

[0037] Referring to FIG. 3C, the information fields associated with the transmission administration **55** are shown. These fields provide information that defines the particular communication being transmitted. Although the number of fields may be more or less, and the type of fields described in this specification may change depending on the particular communication and the requirements of the system **10**. In one embodiment of the present invention the fields associated with transmission administration **55** comprise the following fields: 1) security **61**; 2) priority **62**; 3) in system/out of system **63**; 4) broadcast/point-to-point **64**; 5) communication identifier (data/voice) **65**; 6) communication type (information/control) **66**; and 7) communication length (standalone or continuation) **67**.

[0038] Since the vehicle communication system **10** in accordance with the present invention permits control of a vehicle and overall control of the communication system **10** by law enforcement authorities via a “security instruction”, the system **10** has a plurality of security levels to ensure that unauthorized individuals will not use the system **10** for subversive purposes. Optionally, driver may override law enforcement. System may ask for permission for law enforcement to control vehicle. The security field **61** is defined as follows: 0—access to all functions of the vehicle communication system **10** including the physical control of the vehicle and all of the information stored within the memory **41**. 1—access only to the physical control of the vehicle. 2—access only to the information stored within the memory **41**. 3—access for transmitting and receiving communications. 4—access only to receiving communications.

[0039] The security field **61** may also include a security code, which permits authentication of the entity sending the security instruction. As aforementioned, it should be understood by those skilled in the art that additional fields may be added or defined as desired to increase the functionality of the system **10** or the security layers. Additionally, it should be recognized that although the system **10** is capable of a broad range of functionality, there are legal implications to implementing all of the functionality. For example, a court order would most likely be necessary before permitting law enforcement officials access to information in, or control of, the mobile unit **16**.

[0040] The priority field **62** is an indicator of the urgency of the transmitted communication. The priority field **62** can be a numeric priority from one to ten; with urgent communications having the highest priority of one (e.g., communications from law enforcement officials) and non-urgent communications having the lowest priority of ten, (e.g. advertisements).

[0041] The in system/out of system field **63** indicates whether the communication is destined for, or originated from, another vehicletalk mobile unit **16** or an entity located outside of the vehicle communication system **10**. Communications with entities outside the vehicle communication system **10** can be routed between the vehicletalk mobile unit **16** and the outside entity over the PSTN **22**.

[0042] The broadcast/point-to-point field **64** identifies whether the message is intended for broadcast to all vehicletalk mobile units **16** or whether it is intended to be routed to a particular mobile unit **16**. As will be explained in detail hereinafter, the receiver field **57** will specify the particular address, or multiple addresses, of the mobile units **16** to which the communication will be transmitted.

[0043] The communication identifier field **65** identifies whether the communication is a voice or data transmission since each transmission may be encoded and processed differently by the receiving microprocessor **40**.

[0044] The communication type field **66** identifies whether the communication comprises information for output to the user via the AVI **46**, or whether the information is a control instruction that will permit electro-mechanical control of the vehicle.

[0045] The communication length field **67** indicates whether the entire communication is included within the current packet **50**, or whether the packet **50** is part of a multi-packet communication.

[0046] Referring to FIG. 3D, the fields associated with the sender portion **56** of the header **51** include identification number **71**, position **72**, speed **73**, acceleration or deceleration **74**, direction **75**, origination **76** and destination **77**, and may include many more optional fields **78** as specified by the vehicle operator.

[0047] The identification number **71** provides a unique identification for the sending vehicletalk mobile unit **16**. The identification number may be the vehicle license number with two additional letters representing the state where the license plate was issued such as PA for Pennsylvania. Depending upon system administration, the identification number **71** may further relate to one or more individual operators of the vehicle. As shown in FIG. 3F, the identification number field **71** may comprise a plurality of subfields including vehicle code **81**, number of authorized vehicle operators **82**, a vehicle operator identification number **83a, b . . . n** for each operator. This feature is particularly useful if the vehicle is part of a commercial fleet of vehicles with multiple drivers. Upon turning on the vehicle, the vehicle operator inputs their identification number **71**. This number **71** is compared to the list of authorized operators previously stored in memory **41**. If the input operator identification number **71** matches favorably with one of the authorized operators previously stored in memory **41**, operation of the vehicle is permitted; if not, operation is denied. Optionally, license plate, registration, insurance information and driver’s license information can be additional fields for FIG. 3F.

[0048] Use of a vehicle operator identification number **71**, such as a driver’s license, also permits different operators to use the vehicle while retaining their distinct identity and storing information particular to that vehicle operator, (similar to a screen name for internet use such as the America Online (AOL) system).

[0049] Referring back to FIG. 3D, the next four fields associated with the sender portion of the header **51** include position **72**, speed **73**, acceleration or deceleration **74** and direc-

tion **75**, which are automatically created from the information obtained from the sender's GPS receiver **35**.

[0050] The origination field **76** includes the location of the vehicle when the vehicle was turned on. The destination field **77** includes the destination of the vehicle. This, of course, requires that the destination be input into the mobile unit **16**, such as when a destination is input into a navigation system. It should be understood that the vehicletalk operator may override certain fields to ensure that this information is not obtained by other vehicletalk operators. For example, the origination **76** and destination fields **77**, which may include personal information that the vehicletalk operator does not desire other vehicletalk operators to have access to, may include null data such that the sender's destination and origination will be listed as "not available" to the receiver. The vehicle operator configures their mobile unit **16** as desired to specify which fields should be transmitted with null data.

[0051] Referring to FIG. **3E**, the fields associated with the receiver portion **57** of the header **51** are shown in greater detail. As discussed with reference to FIG. **3C**, the broadcast or point-to-point field **64** indicates whether the communication is destined for one, multiple or all operators. If the communication is to be broadcast to all vehicletalk operators, the number of addressees field **79** is designated as zero, indicating that all operators will receive the communication. For point-to-point or point-to-multipoint communications, (whereby a plurality of operators may be included within a conversation or communication), the number of addressees field **79** includes the number of operators which will be receiving the communication. For example, if a point-to-point communication is desired, the number of addressees field **79** will include the number one (1) and address field number one **80a** will be the only field which includes an address. If a point-to-multipoint communication is desired between, for example four additional vehicletalk operators, the number of addressees field **79** will include the number four (4) and address fields one through four **80a-d** will include the addresses of the four receivers to be sent the communication.

[0052] Once all of the aforementioned fields have been populated with the information, the microprocessor **40** builds each communication packet **50** and forwards the packet **50** to the transceiver **32** for transmission. The packets **50** are preferably transmitted to the base station **14**, and then forwarded to the base station controller **20**. The base station controller **20** routes all of the communication packets **50** to the specified addresses, either to one or more vehicletalk operators, one or more outside entities, or both. This routing function is the same as an internet router, whereby the destination address or addresses are read by the router and the communication packet **50** is forwarded to those addresses. If the communication packet **50** is to be forwarded to multiple addresses or broadcast to all addresses, the base station controller **20** provides such a routing function.

[0053] The base station controller **20** may also confirm to sender whether or not a signal has been received by the recipient. In an alternative embodiment, each communication may require a confirmation packet be sent from the recipient to the sender to provide the confirmation. Using such an embodiment, the sending vehicletalk operator will know whether or not the communication packet **50** has reached its destination.

[0054] Although the present invention has been explained with reference to a plurality of base stations **14** and a base

station controller **20**, the system **10** can also use technology similar to Bluetooth wireless technology. Using technology such as Bluetooth allows mobile units and base stations to communicate through other mobile units and base units (i.e. repeaters). This permits a wireless interconnect between mobile devices, and between mobile devices and their peripherals. The mobile devices can form a secure piconet and communicate among the connected devices. Accordingly, using this technology, vehicletalk mobile units **16** can talk directly to other vehicletalk mobile units **16** without the intervention of the base stations **14** and the base station controller **20**. It is intended that the present invention be used with any type of wireless communication standard including Bluetooth, MPEG2, MP3 or other wireless or data transmission standard. The particular standard used in transmitting the data is not critical since there are many types of wireless technologies and standards that can be used to transfer information between vehicletalk mobile units **16**. It should be recognized that any of the communications could be encrypted by currently known technologies so that only certain authorized vehicletalk vehicles can communicate with each other. For example, if two vehicletalk users were communicating with one another and either requested a private conversation the system can immediately encrypt their communication.

[0055] As should be understood by those of skill in the art, if the address of the receiver is outside of the system **10** and must be routed via the PSTN **22**, the base station controller **20** formats the communication packet **50** in a format that may be handled by the PSTN **22**. Although the present invention has been explained using a general packet **50** "structure" as illustrated by FIGS. **3A-3F**, this structure is intended to serve as an example of the information to be transmitted by the system **10** in each communication. It is not the intention herein to specify a new communication standard since the present invention may be utilized with any current or future wireless communication standard. For example, the packets **50** transmitted over the vehicle communication system **10** may use the internet protocol (IP) format such that they may be transmitted seamlessly to any communication system which uses the IP format. The discussion of the particular format and/or conversion to another format for forwarding over the PSTN **22** is outside the scope of the present invention.

[0056] As shown in FIGS. **4A** and **4B**, the memory **41** is used to store information which populates the aforementioned fields. As will be described in greater detail hereinafter with reference to FIG. **4C**, the memory **41** is also used to store other detailed information which may be helpful to the vehicletalk operator, other vehicletalk operators, the base station controller **20** or law enforcement agencies. The information stored in memory **41** may originate from a received communication, or maybe input into the mobile unit via the AVI **46**. For example, information that is specific to a particular operator, such as those fields illustrated in FIG. **4C**, may be input by the vehicletalk operator via the AVI **46**.

[0057] Referring to FIG. **4A**, one of the uses of the memory **41** is to automatically store a current vehicle activity log **90** and previous entered logs. The vehicle activity log **90** comprises a plurality of fields including the time **90a**, date **90b**, position **90c**, speed **90d**, acceleration/deceleration **90e** and direction **90f** of the vehicle. This log **90** is updated on a periodic basis as determined by the vehicletalk operator. For example, private individuals may desire the log **90** to be updated every 15 minutes whereas commercial businesses may require the log **90** to be updated every 15 seconds or even

less. It should be realized that the vehicle activity log 90, if updated on the order of fractions of a second, would be extremely useful during accident reconstruction.

[0058] Referring to FIG. 4B, a vehicle communication log 92 is shown. The communication log 92 includes the following fields: the time of the communication 92a; the date of the communication 92b; an indication of whether the communication was incoming or outgoing 92c; the address(es) of the communicating entity 92d; the priority of the communication 92e; an indication of whether the communication is broadcast or point-to-point 92f; an indication of whether the communicating entity is within the vehicletalk system or outside the system 92g; the security level of the communicating entity 92h; an indication of whether the communication is data or voice 92i; an indication of whether the communication is information or control 92j; and the actual contents of the communication 92k. The vehicle communication log 92 continually tracks each ongoing communication and stores the contents of the communication in the contents field 92k and all of the related information in the remaining fields 92a-j.

[0059] Referring to FIG. 4C, a vehicletalk operator may input via the AVI 46 a plurality of fields related to the specific user and/or vehicle in a user log 105. One example of a user log 105 is shown in FIG. 4C which includes the following fields: registration number 105a; insurance company 105b; insurance policy number 105c; vehicle make 105d; vehicle model 105e; vehicle color 105f; other identifying information 105g; vehicle model year 105h; EZpass number 105i; garage parking account number 105j; garage door access code 105k; driving record 105l; and credit card information 105m. There is no limit to the number of fields which may be stored in the user log 105, and all fields can be defined by the vehicle operator. Since many of these fields include sensitive information, the vehicle operator may decide not to send any information from the user log 105 and the microprocessor 40, when constructing the data packets, will place null data in those fields.

[0060] The procedure utilized by the microprocessor 40 upon receipt of a communication packet 50 is shown in FIG. 5. The microprocessor 40 first determines whether the incoming packet 50 is addressed to the specific vehicletalk mobile unit 16. Accordingly, at step 502, the microprocessor determines whether the incoming packet is a broadcast, and at step 504, the microprocessor determines whether the specific address matches the vehicletalk mobile unit address. If either of these determinations is affirmative, the new packet is stored (step 506). The microprocessor then determines if there are other communication packets pending for processing (step 508). If no other packets are pending, the new packet is processed (step 510). If applicable, any packets in the queue are reprioritized in accordance with the priority of each packet (step 512) which, in the case where no other packets are pending, would not be necessary. The microprocessor then goes on to reviewing the next packet step (514).

[0061] If it has been determined in step 508 that other packets are pending, the priority of all of the pending packets are reviewed (step 516) and a determination is made (step 518) whether the pending packets have a lower priority than the new packet. If the new packet has a higher priority than the pending packets, the microprocessor halts processing of the pending packet currently being processed (step 520), re-stores the pending packet into memory (step 522) and proceeds with processing the new packet (step 510).

[0062] If, however, the pending packets do not have a lower priority than the new packet, the microprocessor stores the new packet in a queue with all other pending packets (step 524) and continues to process the pending packet (step 526). In this manner, the microprocessor 40 is able to process higher priority packets first, and delay processing of lower priority packets to a more appropriate time when the microprocessor has the proper resources.

[0063] Optionally, even if the microprocessor determines in steps 502 and 504 that the communication is not addressed to the particular vehicletalk mobile unit 16, either as point-to-point communication or as part of a broadcast communication, the microprocessor may still undertake minimal processing of such packets. This is performed in step 530 whereby a contact log is created.

[0064] As shown in FIG. 4D, the contact log 110 may comprise a minimum number of fields such as the time 110a, date 110b, address 110c, color 110d, make 110e, and model 110f of the vehicle related to the incoming communication packet 50. The number and type of fields is determined by the vehicletalk operator. The payload of the packet may not be stored. The contact log 110 is used by the microprocessor 40 to search for "matches" with other vehicletalk operators. Upon request by the vehicletalk operator, the microprocessor 40 searches the contact log 110 for any addresses (i.e., sending addresses) that have multiple entries in the log 110. Once the microprocessor 40 searches the contact log 110 and outputs the addresses which show up on the contact log 110 greater than a certain frequency threshold as set by the vehicletalk operator, the operator can determine whether those addresses should be placed in a "commuter" log; which is a list of vehicletalk operators as identified by their addresses.

[0065] This information is provided to the vehicle operator via the AVI 46. This permits the operator to identify, (either graphically as located on a real-time map or via a list), other vehicletalk operators which may be in the vicinity during a certain portion of the day. For example, during a commute to work if other vehicletalk operators are typically within the vicinity of the present vehicletalk operator during a certain time of day, a "partner log" may be created by each vehicletalk operator to permit vehicletalk operators to identify, contact and establish a rapport with other vehicletalk operators.

[0066] Since the communication packet headers 51 include very detailed information about other vehicletalk mobile units 16, the system 10 can provide extreme flexibility in contacting other vehicletalk operators in the vicinity. For example, if a vehicletalk operator observes a vehicle that they would like to establish a private conversation with, the operator may command the mobile unit 16 to "talk" to blue car. If more than one vehicletalk mobile unit 16 is in a blue car in the vicinity, the microprocessor 40 can filter the commuter log to vehicles having the color blue. If more than one blue car was in the vicinity, the microprocessor 40 presents the make and model of each blue car and requests further instructions.

[0067] Since all of the detailed information is available in the packet header 51, the system 10 can provide the speed, direction and location of the other vehicle in relation to the present vehicle. This information is also important in order to evaluate whether another vehicletalk mobile unit 16 will be available for a conversation having a duration of a minimum length. For example, if a vehicletalk operator notes that one of the vehicle operators on his partner log is currently traveling in the vicinity, and the vehicletalk operator would like to

establish communications with the other vehicletalk operator, the system 10 can calculate the duration of a potential conversation based upon the speed and direction of both vehicles and their ultimate destinations, if available. The system 10 can combine that information and advise both vehicletalk operators by an audible alarm or a voice message that there is a certain amount of time left in the conversation. The microprocessor 40 can also filter out any vehicletalk mobile units 16 that will not be in the range long enough to establish a reasonable conversation.

[0068] Referring back to FIG. 5, at step 540, the microprocessor 40 reviews all incoming communication packets 50 to determine if a particular communication packet 50 originates from an address that is on the vehicle operator's partner log. As the communication packets 50 are reviewed at step 540, the vehicletalk operator is notified and can decide whether or not they want to establish a communication with the particular vehicle operator having the address that has compared favorably with the partner log. It should be noted that vehicle operators can block out transmissions being received from particular individuals or cancel conversations at any time. Further, vehicle talk operators can require information such as driver's license, license plate and registration to be provided before they allow any other transmissions to be received.

[0069] Referring to FIG. 6, the procedure for processing communication packets 50 by the microprocessor 40 is shown. The microprocessor first parses the packets into separate fields (step 602) and stores all of the fields that do not require additional processing (step 604). The microprocessor then determines whether a packet includes a data communication by viewing the communication identifier field (step 606). If the microprocessor determines that the packet is not carrying a data communication, then it is a voice communication and the microprocessor processes the communication as such (step 608).

[0070] If the packet includes a data communication, the microprocessor must make a determination whether the data communication is a control communication (step 610). If it is not a control communication, the data communication is an information communication and it is processed as such (step 612). Examples of packets which include information communications include audio, visual and text files that are downloaded over the internet, facsimile transmissions, and transmissions from peripheral devices such as laptop computers, handheld palm devices and the like.

[0071] If it has been determined that the packet includes a control communication, the communication is processed as such (step 614). The microprocessor compares the control instruction to the security level required (step 616). This includes reviewing the security field, including the optional security access code. If the security access code is proper (i.e. authorized), the security level is reviewed and the microprocessor makes a determination of whether the security level is sufficient (step 618). If so, the microprocessor performs the control instruction (step 620). If not, the microprocessor generates a transmission to the sender of the control instruction that they are not authorized to control the particular mobile unit (step 622). The microprocessor 40 also notifies the particular vehicletalk operator that a control attempt was made and was unsuccessful. This will alert the vehicletalk operator that someone may be utilizing the system for subversive purposes. Optionally, the system may require the vehicle talk operator to authorize their vehicle to accept a control instruc-

tion, prior to undertaking any control instructions. Once the processing of the packet is performed, the microprocessor goes to the next packet (step 624).

[0072] With respect to the step of performing a control instruction (step 620), this may include instructions for the microprocessor to exert electromechanical control over certain aspects of the vehicle's operation, or may simply include a request for the microprocessor to upload data to the recipient. For example, if the control instruction is a request for the microprocessor to upload information, the microprocessor may upload one or a plurality of the fields shown in FIG. 4C.

[0073] In a first example relating to a request for information, if the vehicle is entering a toll booth which utilizes the EZpass system, the control instruction from the transmitting toll booth may request that the EZpass number be transmitted. The microprocessor 40 will transmit the number in the EZpass number field shown in FIG. 4C in response thereto.

[0074] In a second example relating to a request for information, a request for information may occur in a parking garage, gas station or any other establishment which requires payment from the vehicle operator, such as a drive-in fast-food restaurant. In this example, the vehicle operator will drive up to an ordering kiosk and order the desired food. After the food has been ordered, the driver pulls up to the window whereby the proper food order is presented to the driver. Meanwhile, the restaurant's communication system sends a communication requesting the credit card information for billing purposes. The information shown in the credit card information field 105m of FIG. 4C can then be presented to the communication system of the restaurant for payment. Optionally, the vehicle talk operator may require that they must first approve of any information being released. Moreover, the communication log for both the fast-food restaurant and the vehicle may store the communication noting the charge amount. For the vehicle it can be a "virtual receipt".

[0075] With respect to an instruction which exerts electromechanical control over the vehicle, as shown in FIG. 2, the electromechanical interface 44 will interface with those systems of the vehicle over which the vehicletalk mobile unit 16 has control. These systems may include the radio, lights, horn, steering, breaking and any other electromechanical systems of the vehicle. For example, if a vehicletalk operator is listening to their favorite radio station and a point-to-point or broadcast communication is received by the mobile unit 16, the microprocessor 40 through the electromechanical interface 44 will stop the radio, or turn down the volume of the radio, so that a vehicletalk conversation can commence.

[0076] It should be understood that due to the amount of information set forth in the header 51 of each communication packet 50, the system 10 provides extreme flexibility in processing and filtering communications. For example, the microprocessor 40 can be programmed to accept only communication from certain makes and models of vehicles. As such, the system 10 set up as part of a Mercedes can be programmed by the manufacturer to be able to talk to only other Mercedes operators.

[0077] The present invention has the ability to greatly increase safety to drivers and can be a valuable resource for emergency services personnel and law enforcement personnel. For example, emergency vehicles can automatically send signals to warn motorists that an emergency vehicle is approaching. This may supplement the emergency light and siren which are standard on emergency vehicles. Since the packets 50 are prioritized, a communication sent from an

emergency vehicle in transit may have the highest priority and can override all other signals having a lower priority. At the scene of an accident, the signal output from an emergency vehicle may, at a slightly lower priority, transmit instructions for avoiding the accident scene and may provide detour instructions.

[0078] With respect to motor vehicle code enforcement, law enforcement agencies can automatically review the status of a driver, vehicle registration and insurance and may provide warnings for expired or soon to be expired license, registrations or insurance policies.

[0079] If an authorized operator has gained access to the vehicle and has not input the proper operator identification number, the microprocessor **40** can transmit an emergency instruction to alert law enforcement agencies that the vehicle has been stolen. The signal sent from the vehicle can automatically include the vehicle's position, speed, acceleration or deceleration rate and direction. Law enforcement officials may send an instruction in response to limit the vehicle speed to no greater than 30 miles per hour until the unauthorized operator of the vehicle is apprehended. It should be noted that various fixed units may be strategically placed along highways, major intersections, toll booths and bridges to monitor traffic and to relay messages back to law enforcement agencies.

[0080] Another law enforcement use can be to limit speeding of vehicles by notifying law enforcement agencies when a vehicle has exceeded a certain speed limit, e.g., 20% over the speed limit. A law enforcement official, in response, may send an instruction for the vehicle to slow down or risk a traffic citation. This can eliminate the need for "speed traps" and high speed police chases.

[0081] For public safety applications, specifically located fixed units can warn drivers as the vehicle approaches a traffic light at an intersection that the vehicle must slow down or stop because it will not "make" the green light. The traffic light can make this determination based upon the speed and direction of the mobile unit and the cycle of the traffic light. Other selectively placed fixed units can warn drivers that an intersection or roadway is dangerous for various reasons, such as an accident, a sharp bend or heavy traffic. The signals output by these locations can be periodically updated as weather and traffic conditions change. In the same manner, vehicles may be warned that a particular vehicle is driving in an erratic manner or that law enforcement officials are currently involved in a pursuit of the vehicle. The warnings to drivers are output through the AVI **46** and may comprise an audible warning, or may comprise a status light such as red, yellow and green being located on the graphical operator interface of the AVI **46**. In extreme circumstances, selectively placed fixed units may automatically overtake control of a vehicle, for example, during extremely icy conditions to slow the vehicle prior to the danger zone.

[0082] It should be noted that although the mobile units **16** were described hereinbefore as being located in a vehicle or in a fixed location, they can be incorporated as part of a cellular phone or palm unit that is portable.

[0083] The present invention is particularly adaptable for interfacing with the internet and providing a wealth of information for all vehicletalk operators. In one internet-related embodiment such as vehicletalk.com, the website permits storage of information and system administration through the internet. A system administrator operating at the website or the base station controller **20** monitors and track all vehicle-

talk mobile units **16**. Through the system administrator, the fixed locations are provided with weather and traffic updates or advertisements which are specifically geared to the immediate vicinity of the vehicletalk fixed unit. In this manner, advertisers advertise both on the vehicletalk.com website and advertise their companies and products as vehicles approach or pass certain properties, stores or business locations. This also permits stores to provide information to vehicles arriving or leaving the place of business, such as directions for parking or thanking them for their patronage.

[0084] The system administrator also provides centralized housekeeping functions in order to track all different types of information that are typically a nuisance to vehicle operators, such as the date their registration and insurance policy expire. The system administrator also tracks general vehicle maintenance information and traffic violation records. The tracking of vehicle maintenance can be particularly useful when a recall notification is issued from a manufacturer or even when regularly scheduled maintenance is required.

[0085] In a second internet-related embodiment, the system **10** is used to aid law enforcement official and insurance companies to determine when a traffic accident has occurred and to collect all of the detailed information regarding the traffic accident. This function is centralized in a website such as vehicleaccident.com. When an accident occurs, a signal is automatically sent to all vehicles involved (or in the vicinity) to transmit all pertinent information to vehicleaccident.com. This can include time, speed, direction, acceleration and deceleration, duration of trip and other pertinent information such as the vehicle maintenance records, traffic citation records insurance and registration information. The system **10** permits all of this information to be stored in a centralized location at vehicle accident.com for later review by law enforcement officials. The system **10** also stores law enforcement officials reports regarding the accident.

[0086] The insurance industry should benefit by having vehicletalk operators agree in advance to accept a fact finding by an officer utilizing all of the information from the vehicletalk mobile units **16**. This avoids costly litigation and subrogation. A vehicletalk operator accepting these terms may be permitted special insurance discounts for agreeing to such.

[0087] In another embodiment, the system can provide mobile units that do not include a GPS unit. It can be similar to portable phone(s) operating on the same frequency(s). If a user tunes their radio to a particular station, they can receive a transmission through their car stereo system. The mobile unit, in this instance, can have the microphone inside of it so a user can speak "hands free". This embodiment allows the mobile unit to beep (or voice activate) if another user comes within range advising both mobile units that they have someone they can talk to. The mobile unit detects another mobile unit by actually receiving the signal of the other mobile unit. Accordingly, positioning of either mobile unit is not required.

[0088] Although the invention has been described in part by making detailed reference to the preferred embodiment, such detail is intended to be instructive rather than restrictive. It will be appreciated by those skilled in the art that many variations may be made in the structure and mode of operation without departing from the spirit and scope of the invention as disclosed in the teachings herein.

What is claimed is:

- 1. A management system comprising:
 - circuitry configured to send, via a cellular data network using internet protocol (IP) to a vehicle, vehicle maintenance and operation information;
 - the circuitry is further configured to send, via the cellular data network using IP, an instruction to remotely control locks or a horn of the vehicle; and
 - wherein the instruction is provided based on a plurality of security levels and based on a request for permission of control of the vehicle.
- 2. The management system of claim 1, wherein the management system is capable of contacting law enforcement.
- 3. The management system of claim 1 further comprising:
 - circuitry configured to receive, from the vehicle, a notification of an unauthorized operator accessing the vehicle; and
 - wherein the accessing of the vehicle indicates that the vehicle was stolen.
- 4. The management system of claim 1 wherein a connection to the internet over the cellular data network is provided to the vehicle.
- 5. A vehicle computer configured in a vehicle, the vehicle computer comprising:
 - the vehicle computer configured to receive, via a cellular data network using internet protocol (IP), vehicle maintenance and operation information;
 - the vehicle computer is further configured to receive an instruction, via the cellular data network using IP, to remotely control locks or a horn of the vehicle; and
 - wherein the instruction is provided based on a plurality of security levels and based on a request for permission of control of the vehicle.
- 6. The vehicle computer of claim 5, wherein the vehicle computer is capable of contacting law enforcement.
- 7. The vehicle computer of claim 5, wherein unauthorized access of the vehicle indicates that the vehicle was stolen.
- 8. The vehicle computer of claim 5, further comprising:
 - the vehicle computer is configured to connect to the internet over the cellular data network.

- 9. A method performed by a management system, the method comprising:
 - sending, by the management system to a vehicle via a cellular data network using internet protocol (IP), vehicle maintenance and operation information;
 - sending, by the management system via the cellular data network using IP, an instruction to remotely control locks or a horn of the vehicle; and
 - wherein the instruction is provided based on a plurality of security levels and based on a request for permission of control of the vehicle.
- 10. The method of claim 9, wherein the management system is capable of contacting law enforcement.
- 11. The method of claim 9 further comprising:
 - receiving, by the management system from the vehicle, a notification of an unauthorized operator accessing the vehicle; and
 - wherein the accessing of the vehicle indicates that the vehicle was stolen.
- 12. The method of claim 9 wherein a connection to the internet over the cellular data network is provided to the vehicle.
- 13. A method performed by a vehicle computer configured in a vehicle, the method comprising:
 - receiving, by the vehicle computer via a cellular data network using internet protocol (IP), vehicle maintenance and operation information;
 - receiving, by the vehicle computer via the cellular data network using IP, an instruction to remotely control locks or a horn of the vehicle; and
 - wherein the instruction is provided based on a plurality of security levels and based on a request for permission of control of the vehicle.
- 14. The method of claim 13, wherein the vehicle computer is capable of contacting law enforcement.
- 15. The method of claim 13, wherein unauthorized access of the vehicle indicates that the vehicle was stolen.
- 16. The method of claim 13, further comprising:
 - connecting, by the vehicle computer, to the internet over the cellular data network.

* * * * *