

M. MARCIL.

MECHANISM FOR ACTUATING NEEDLE BARS.

No. 331,204.

Patented Nov. 24, 1885.

Fig:2.

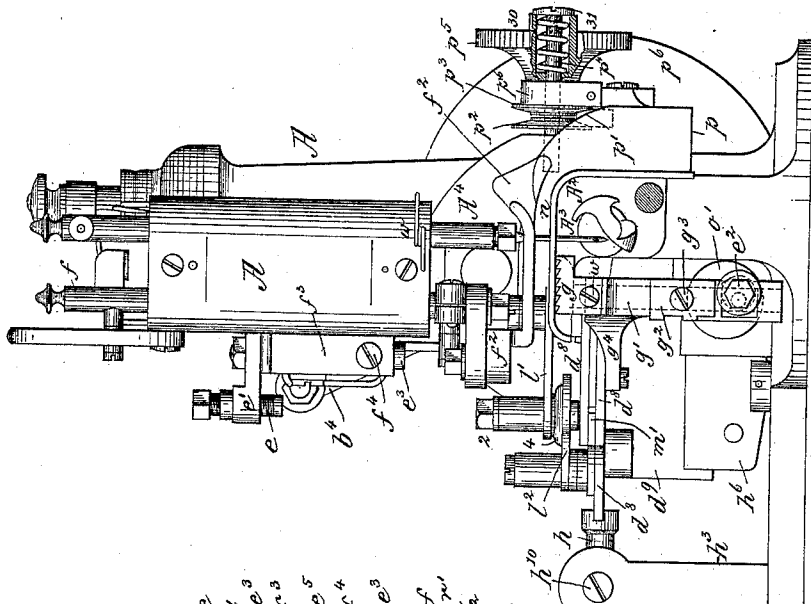
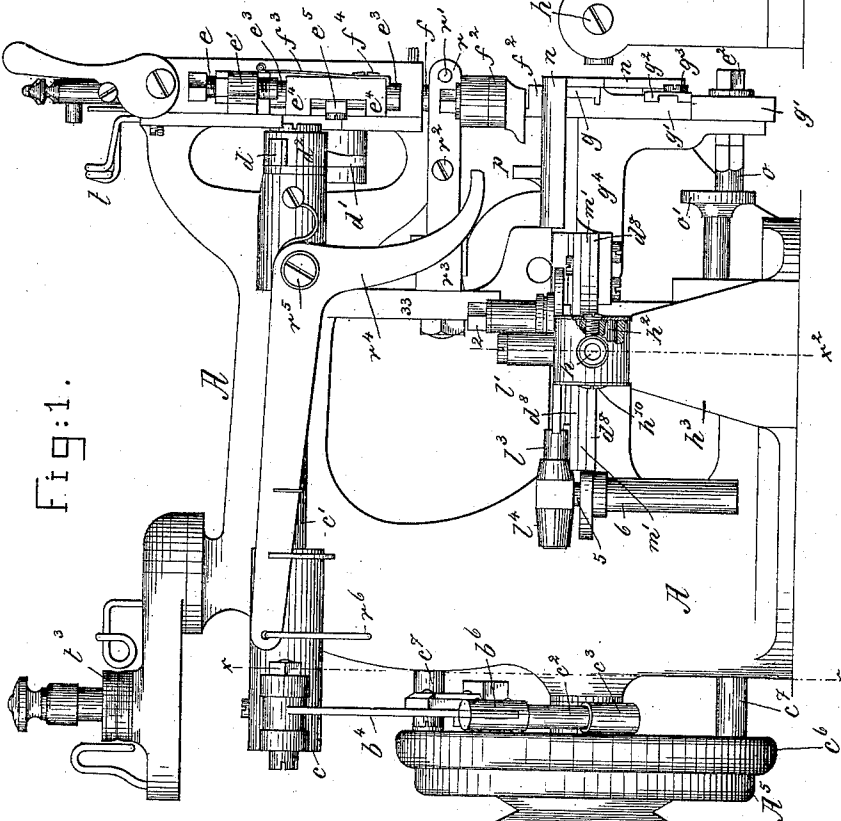

Fig:1.



Witnesses.

Arthur Lippertsen.
John P. C. Prinkhorn

Inventor.

Michael Marcil,
by Crosby & Gregory
attys

M. MARCIL.
MECHANISM FOR ACTUATING NEEDLE BARS.

No. 331,204.

Patented Nov. 24, 1885.

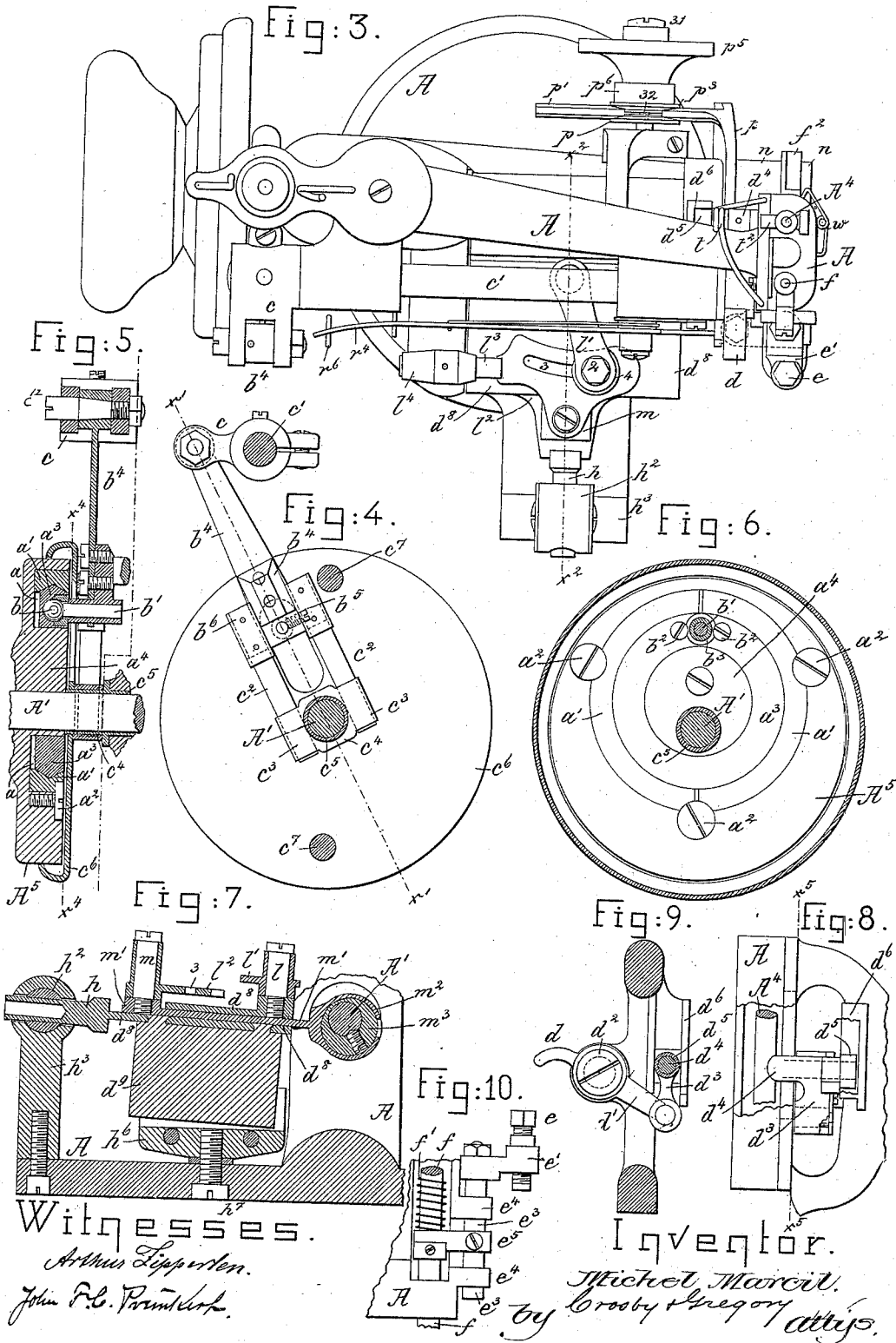

UNITED STATES PATENT OFFICE.

MICHEL MARCIL, OF AMHERST, MASSACHUSETTS, ASSIGNOR TO THE HILLS COMPANY, OF SAME PLACE.

MECHANISM FOR ACTUATING NEEDLE-BARS.

SPECIFICATION forming part of Letters Patent No. 331,204, dated November 24, 1885.

Application filed September 15, 1884. Serial No. 143,133. (No model.)

To all whom it may concern:

Be it known that I, MICHEL MARCIL, of Amherst, county of Hampshire, State of Massachusetts, have invented an Improvement in Sewing-Machines, of which the following description, in connection with the accompanying drawings, is a specification, like letters on the drawings representing like parts.

The invention herein contained relates especially to improvements in mechanism for actuating the needle-bar, my invention being an improvement on the machine represented in United States Patent No. 292,124.

My invention consists in a needle-bar-actuating rock-shaft, its attached rocker, a needle-bar, its connected link and horizontally-extended pin, and a block pivoted thereon, combined with a guide into which the said block is extended, as will be described; also, in the combination, with the main shaft, its attached wheel, eccentric, eccentric ring and gib, and pin having a ball-like head and a rock-shaft, and a connecting-rod to join it with the pin, of a needle-bar and connecting mechanism between it and the needle-actuating rock-shaft, substantially as will be described.

Other features of invention will be described in the claims at the end of this specification.

Figure 1 in side elevation represents a sewing-machine embodying my improvements; Fig. 2, a front end elevation thereof, part of the gage-adjusting device being shown as broken out; Fig. 3, a top or plan view; Fig. 4, a section in the line $x x$, Fig. 1, looking toward the left; Fig. 5, a section of Fig. 4 in the line $x' x'$. Fig. 6 is a section of Fig. 5 in the line $x'' x''$, showing the eccentric and other parts to be described which form part of the mechanism for actuating the needle-bar. Fig. 7 is a partial vertical section in the lines x^2 , Figs. 3 and 1. Fig. 8 is a detail in side elevation, partially broken out to illustrate the guide employed to prevent the needle-bar from being rotated as it is reciprocated; Fig. 9, a section of Fig. 8 on the line $x^3 x^3$; and Fig. 10, a detail of the auxiliary presser-bar and the main presser-bar and its spring.

The frame-work A of the machine, of proper shape to sustain the working parts, has a main

rotating shaft, A', provided at its front end 50 with a hook, A², of well-known construction to co-operate with the needle A³ in the needle-bar A⁴ for the formation of a chain-stitch. The shaft A', at its rear end, is provided with a wheel, A⁵, properly shaped to receive a driving-band, the said wheel being provided at its inner side with an eccentric groove, a , in which are placed semicircular gibs $a' a'$, which are held in place by the screws a^2 , the said gibs being V-shaped in cross-section, and serving 55 as guides for the eccentric-ring a^3 , which surrounds the eccentric a' , attached to or forming part of the said wheel, as best shown in Figs. 4 to 6. The eccentric-ring a^3 is provided with a seat for the reception of the ball-like head b 65 of a pin, b' , which is secured loosely in place in the said ring by screws b^2 acting against a cap, b^3 . (See Fig. 6.) The pin b' receives over it the socketed lower end of the connecting-rod b^4 , attached to the arm c of the needle-bar-actuating rock-shaft c' by the tapering bolt c^2 , the said rod and pin being secured together by the set-screw b^5 . (See Fig. 4.) The 70 connecting-rod b^4 has a cross-head, b^6 , to which are secured two guide-rods, c^3 , which at their lower ends enter guides or eyes $c^3 c^3$ of a collar, c^4 , loose on a bushing, c^5 , about the main shaft A'. Preferably the inner face of the wheel A⁵ will be covered by a stationary cap, c^6 , joined by pins c^7 to the main frame 80 A. By the employment of the eccentric-ring and the pin having the ball-like head, to which the connecting-rod is pivoted, the movement of the latter is produced with the least amount of strain and vibration. By the 85 employment of the pin having the ball-like head all irregularities in strain between the connecting-rod and ring are obviated. The needle-bar-actuating rock-shaft, at its front end, is provided with a rocker having two 90 arms, $d d'$, secured thereto by a screw, d^2 . The arm d' of this rocker is connected by link d^3 with a pin, d^4 , projecting from the needle-bar A⁴ at its rear side, the said pin at its rear end entering a socket of a block, d^5 , having two 95 straight sides and fitted into a vertical guide, d^6 , attached to or forming part of the frame-work, such block and guide insuring the move-

ment of the needle-bar in its guides in the head without twisting, and also obviating draft-strain on the link d^3 . The arm d of the rocker is adapted as the needle-bar descends 5 to act upon the screw e of the arm e' , pivoted on the auxiliary presser-bar e^2 , which is adapted to slide up and down in the guides e^4 , forming part of the rigid frame-work. This auxiliary presser-bar (see Figs. 1 and 10) has attached 10 to it a forked arm or finger, e^5 , which is extended laterally to and past the main presser-bar f and under the usual spiral spring, f' , which normally acts to keep the presser-foot f^2 , attached thereto, down upon the work. The 15 arm e' is provided with a head having two flat faces, and a spring, f^3 , attached by screw f^4 , acts against one or the other of the said faces to hold the said arm in either of its two positions. When a hat is to be commenced at the 20 tip of the crown, the braid, while the needle is down, should be subjected to the least possible pressure to permit the work to be turned on the needle as a center, and to provide for this the arm e' may be turned into the position 25 shown by dotted lines, Fig. 3, and thereafter the arm d at each descent of the needle will act upon the arm e' or the screw e therein and lift the bar e^2 , so that its attached arm e^5 will by its action on the spring f' relieve the regu- 30 lar presser-foot f^2 and its bar of the pressure of the said spring.

The presser-bar lifting device referred to forms the subject-matter of an application, Serial No. 171,320, and the feeding mechanism 35 shown, as also the gage, form subject-matter of two applications, Serial Nos. 171,319 and

171,318, subdivided from this in accordance with the requirements of the Patent Office, and hence said features are not herein claimed.

I do not broadly claim a pin having a ball-like head as a connecting device, for such is old in United States Patent No. 198,705.

I claim—

1. The needle-bar-actuating rock-shaft, its attached rocker, the needle-bar, its connected 45 link and horizontally-extended pin, and the block pivoted thereon, combined with the guide into which the said block is extended, substantially as described.

2. In a sewing-machine, the main shaft, its 50 attached wheel and eccentric, and the eccentric ring and gib, and the pin having a ball-like head and entering a seat in the said ring, and the connecting-rod and the needle-bar-actuating rock-shaft and its rocker, combined 55 with the needle-bar and intermediate connecting mechanism, substantially as described.

3. The main shaft A' , the wheel A^2 , its eccentric and the eccentric-ring, and the pin b' , having the globular head, and the cap b^3 , at- 60 tached to the eccentric-ring loosely and holding the pin, combined with the needle-bar-actuating rock-shaft and the connecting-rod b^4 , to operate substantially as described.

In testimony whereof I have signed my 65 name to this specification in the presence of two subscribing witnesses.

MICHEL MARCIL.

Witnesses:

LEONARD M. HILLS,
F. H. WALKER.