

(19) **DANMARK**

(10) **DK/EP 1692918 T3**



(12) **Oversættelse af
europæisk patentskrift**

Patent- og
Varemærkestyrelsen

-
- (51) Int.Cl.: **H 04 R 25/00 (2006.01)**
- (45) Oversættelsen bekendtgjort den: **2018-11-26**
- (80) Dato for Den Europæiske Patentmyndigheds bekendtgørelse om meddelelse af patentet: **2018-08-15**
- (86) Europæisk ansøgning nr.: **04797470.4**
- (86) Europæisk indleveringsdag: **2004-11-22**
- (87) Den europæiske ansøgnings publiceringsdag: **2006-08-23**
- (86) International ansøgning nr.: **DK2004000809**
- (87) Internationalt publikationsnr.: **WO2005055655**
- (30) Prioritet: **2003-12-05 DK 200301802**
- (84) Designerede stater: **AT BE BG CH CY CZ DE DK EE ES FI FR GB GR HU IE IS IT LI LU MC NL PL PT RO SE SI SK TR**
- (73) Patenthaver: **Oticon A/S, Kongebakken 9, 2765 Smørum, Danmark**
- (72) Opfinder: **FREDERIKSEN, Peter, c/o OTICON A/S, Strandvejen 58, 2900 Hellerup, Danmark**
- (74) Fuldmægtig i Danmark: **Oticon A/S, Kongebakken 9, 2765 Smørum, Danmark**
- (54) Benævnelse: **KOMMUNIKATIONSANORDNING MED MIKROFON**
- (56) Fremdragne publikationer:
WO-A-00/74915
DE-B- 1 153 797
US-A- 3 123 678
US-A- 3 239 093
US-A- 3 359 377

DESCRIPTION

AREA OF THE INVENTION

[0001] The invention concerns a head worn communication device with at least one microphone. In modern communication devices like hearing aids or head sets a microphone is often placed inside a casing, which is associated with the ear of the user of the communication device.

BACKGROUND OF THE INVENTION

[0002] The microphone inside the casing usually has access to the surrounding air through a canal and an orifice in the casing of the communication device. If a sound tight fit between the orifice in the casing and the canal is not provided, there is a risk that sounds provided to the ear from a possible sound generating device in the casing may leak into the microphone canal and cause feedback problems. Further an air and fluid tight fit between the orifice in the casing and the canal is advantageous, as this aids to prevent foreign substances such as sweat, salt or dust from entering or migrating into the casing, where such substances would harm the delicate electronic components of the device. In head worn communication devices it is also desired that the microphone opening in the casing should be as inconspicuous as possible in order not to draw unnecessary attention to the device.

[0003] In prior art document US 3239093 a hearing aid is disclosed wherein two shell parts having matching rim portions enclose the electronic components, and where opposing recesses of the rim portions define openings for battery access and for sound input to the microphone.

[0004] Prior art document WO 00/74915 describes the use of multicomponent injection technique in generating a gasket material along a rim of a casing part in a hearing aid.

SUMMARY OF THE INVENTION

[0005] It is an object of the invention to provide a hearing aid as claimed in claim 1.

[0006] Preferred embodiments of the invention are disclosed in claims 2 and 3.

BRIEF DESCRIPTION OF THE DRAWINGS

[0007]

Fig. 1 shows an exploded view of a communication device according to the invention,

Fig. 2 shows the receiver assembly,

Fig. 3 shows an exploded view of the receiver with receiver suspension parts,

Fig. 4 is a cross section through the outlet from the receiver enclosure.

DESCRIPTION OF A PREFERRED EMBODIMENT

[0008] The exploded view of fig. 1 displays the various parts of the hearing aid. The hearing aid comprises a bottom shell 1 and a top shell 20. When assembled the bottom shell 1 and the top shell 20 encloses a receiver assembly 50 and the microphones 11, 12. A hook 7 is insertable into the bottom shell 1 in order to provide a sound guide from the receiver 60 to the surroundings.

[0009] The receiver assembly 50 is described in more detail with respect to figs. 2 and 3. The receiver 60 has a sound outlet opening (not visible) in a first side and a flexible tube part 62 is coupled to the sound opening. The flexible tube 62 is shaped along with a tube 63 in order to form a combined sound outlet duct and receiver suspension part. At a side 67 the receiver has connection terminals 64 and also a further flexible suspension pole 66 is arranged at this side. The receiver assembly in fig. 2 comprises the receiver 60 with suspensions 66, 62 and a receiver enclosure cover 50.1. This cover 50.1 has a first wall part 59 extending along the first side 69 of the receiver 60 and a second wall part 58 extending along the second side 68 of the receiver 60. From the second wall part 58 a beam 52 extends along the third side 67 of the receiver 60. The first wall part 59 has means for receiving and holding the tube 63, and the beam 52 has means for receiving and holding the pole 66. When the receiver is assembled to the receiver enclosure cover 50.1, the receiver is suspended by the pole 66 and the flexible tube 62. Both the tube 63 and the pole 66 extend through respective openings in the wall part 59 and the beam 52 respectively. The flexible bellows part 62 and the pole 66 are both made of a flexible polymer, such that the suspended receiver 60 may move in any direction. This helps to absorb any vibrations coming from the receiver or coming from handling the hearing aid, such that the receiver is vibrational isolated from the remaining hearing aid once assembled therewith.

[0010] As seen in figs. 2 and 3 a further shock absorbing means 70 is provided which prevents the receiver from bouncing on the internal walls of the enclosure.

[0011] In fig 1 it is shown how the receiver assembly may be placed in the bottom shell 1 of the hearing aid. The bottom shell comprises a bottom wall 2, two side walls 3,4 and a battery

enclosure wall 5. These four walls, together with the two walls 58, 59 of the receiver enclosure cover 50.1 form a receiver cabinet which is completely isolated from the remainder of the interior of the hearing aid. In order to achieve a sound tight seal between the wall parts of the hearing aid and the receiver enclosure cover 50.1, the receiver enclosure cover 50.1 has a flexible sealing material 51 placed along the edges of the first and second wall parts 58, 59.

[0012] The electric connection to the receiver 60 is accomplished by use of flexible wires, which are soldered to the connection points 64 and connected to connection pins 65 embedded in the wall part 58.

[0013] The hook 7 shown in fig. 1 has a straight tube part 8 and a connection part 9. The straight tube part is to be inserted in the bottom shell 1 through an orifice and into the tube 63. In this way sound may be guided through tube 63, the straight tube part 8 and to the connection part 9. At the connection part 9 a flexible tube is to be connected to the hook in order to guide the sound to the ear of the user. As seen in fig. 4 the receiver enclosure cover 50.1 has an opening 53, and the tube 63 is positioned inside this opening 53. The tube part 8 of the hook 9 is then placed inside the tube 63 and embraced by the inside surface of opening 53. In this manner it is ensured that sound cannot radiate from any radially extending surface of the tube 63, as no radial part thereof extend outside the opening 53. Both the receiver casing and the sound path to the ear of the user are then sealed acoustically off from the remainder of the hearing aid and no sound will leak to the microphones and cause feed-back even at high output levels of the receiver. The hermetic receiver enclosure also provides the possibility to use a vented receiver. Such a receiver uses the inside of the receiver enclosure described as part of the back volume with respect to the receiver membrane and this provides the possibility of a better receiver performance. A vent opening 6 is shown in the receiver wall.

[0014] The receiver 60 and the microphones 11, 12 are connected by usual electrical circuitry (not shown) which also comprises a signal processing unit (not shown) and a battery. In the present embodiment a front microphone 11 and a back microphone 12 are shown, but one, three or more microphones may be employed. The electrical circuitry gains connection with the connection pins 65 which are embedded in the wall part 58 of the receiver enclosure cover 50.1.

[0015] The top shell 20 has an edge outline which matches the top edges of side wall 3,4 of the bottom shell part 1. Along the edge outline of the top shell 20 a sealing material 21 is placed. This sealing material 21 is interrupted at places 23, 24 in order that the microphone inlets 13,14 of the microphones 11, 12 may gain access to the surrounding. As seen in fig. 1 the microphones 11, 12 are placed symmetrically in the centre of the hearing aid and the microphone inlets 13, 14 are open to both sides of the hearing aid, and thus the interruptions 23, 24 in the sealing material 21 of the top shell 20 are provided at both sides to accommodate the microphone inlets. In this way both the top-shell 20 and the microphone inlets 13, 14 will have the same shape for both right and left side hearing aids. If wished, the microphone inlets pointing towards the users head when the hearing aid is placed on the ear may be filled out with a plug of suitable material. This can happen at the production facility or at the final

dispenser, who sells the hearing aid to the end-user. Having the microphone inlets placed in the sealing line between the two shell parts has the further advantage, that when the two shell parts are pressed together a tight seal is obtained between the microphone inlets and the shell parts. This aid to avoid the penetration into the hearing aid of contaminating substances such as sweat or dust which otherwise could damage the delicate electronic parts of the hearing aid. This further aids to prevent sounds generated by the receiver inside the hearing aid casing to leak into the sound inlet openings of the microphones. The two packing lines: the line between the two shell parts and the line between the receiver enclosure cover together assures, that no sound will leak from the receiver and through the air reach the microphones. Also the placement of the microphone inlets in the packing material renders the microphone inlets less visible which lends more possibilities for agreeable designs of the hearing aid.

[0016] It should be noted, that the receiver suspension described in detail here serves the purpose of isolating the receiver from the remainder of the hearing aid with regards to mechanical vibration transmitted through the casing wall, and this is a necessary requirement if the full benefit of the sound isolation between receiver and microphone inlets is to be enjoyed.

[0017] Preferably the sealing material at the sealing lines 51 and 21 are applied in a multi component injection moulding technique.

[0018] The receiver sub assembly 50 of fig. 2 is produced and may easily be placed in the bottom shell 2 as seen from fig. 1. The receiver sub assembly 50 may be held in place by suitable and well known click connections (not shown). Placement of the receiver 60 with suspensions 66, 62 in the receiver assembly cover 50.1 is done by drawing the tube 63 through the hole in the wall part 59 and likewise placing the pole 66 through the hole or slot in the beam 52. If the receiver should mal-function it is easily exchanged. This is done simply by lifting the receiver assembly cover 50.1 out of the hearing aid and removing the connection wires from their connection points with the receiver. Thereafter the receiver is easily removed from the receiver assembly cover, and a new receiver can be manually inserted to take its place. Soldering the connection wires to the new receiver is a formality.

[0019] Also the suggested positioning of the microphone inlets in the parting line between the two shell parts provides possibility of very simple microphone suspension. Also exchange of a microphone will be easy because the microphones are immediately accessible when the two parts of the hearing aid are taken apart. When the receiver is isolated from the rest of the hearing aid with respect to sound and vibration as described above it becomes possible to suspend the microphone without the use of flexible suspension means as is otherwise the usual practise. This simplifies the hearing aid as fewer components are necessary.

REFERENCES CITED IN THE DESCRIPTION

This list of references cited by the applicant is for the reader's convenience only. It does not

form part of the European patent document. Even though great care has been taken in compiling the references, errors or omissions cannot be excluded and the EPO disclaims all liability in this regard.

Patent documents cited in the description

- US3239093A [0003]
- WO0074915A [0004]

Patentkrav

1. Høreapparat, der omfatter

en nederste skal (1) og en øverste skal (20),

5 hvor den nederste skal (1) og øverste skal (20) indeslutter en modtagerindkapsling (50) og i det mindste en eller flere mikrofoner (11, 12), der hver omfatter en mikrofonindgang (13, 14),

10 hvor den øverste skal (20) har et kantomrids, som omfatter et tætningsmateriale (21), der strækker sig langs kanten af kantomridset, hvor kantomridset passer til kanter på sidevægge (3, 4) på den nederste skal (1), hvor tætningsmaterialet (21) er i form af en pakning, og tætningsmaterialet (21) omfatter i det mindste en eller flere afbrydelser (23, 24), som er indrettet til at tillade mikrofonindgangene (13, 14) for den i det mindste ene eller de flere mikrofoner (11, 12) adgang til omgivelserne, kendetegnet ved, at to afbrydelser (23, 24), der er placeret ved to modstående sider af høreapparatet, er tilvejebragt for hver mikrofonindgang (13, 14).

20 2. Høreapparat ifølge krav 1, kendetegnet ved, at den nederste skal (1) er indrettet til at hvile bag brugerens øre, og den øverste skal (20) er indrettet til at danne et dæksel for høreapparatet.

25 3. Høreapparat ifølge et hvilket som helst af kravene 1 til 2, hvor mikrofonindgangene (13, 14) afbryder tætningsmaterialet (21) helt eller kun delvist.

DRAWINGS

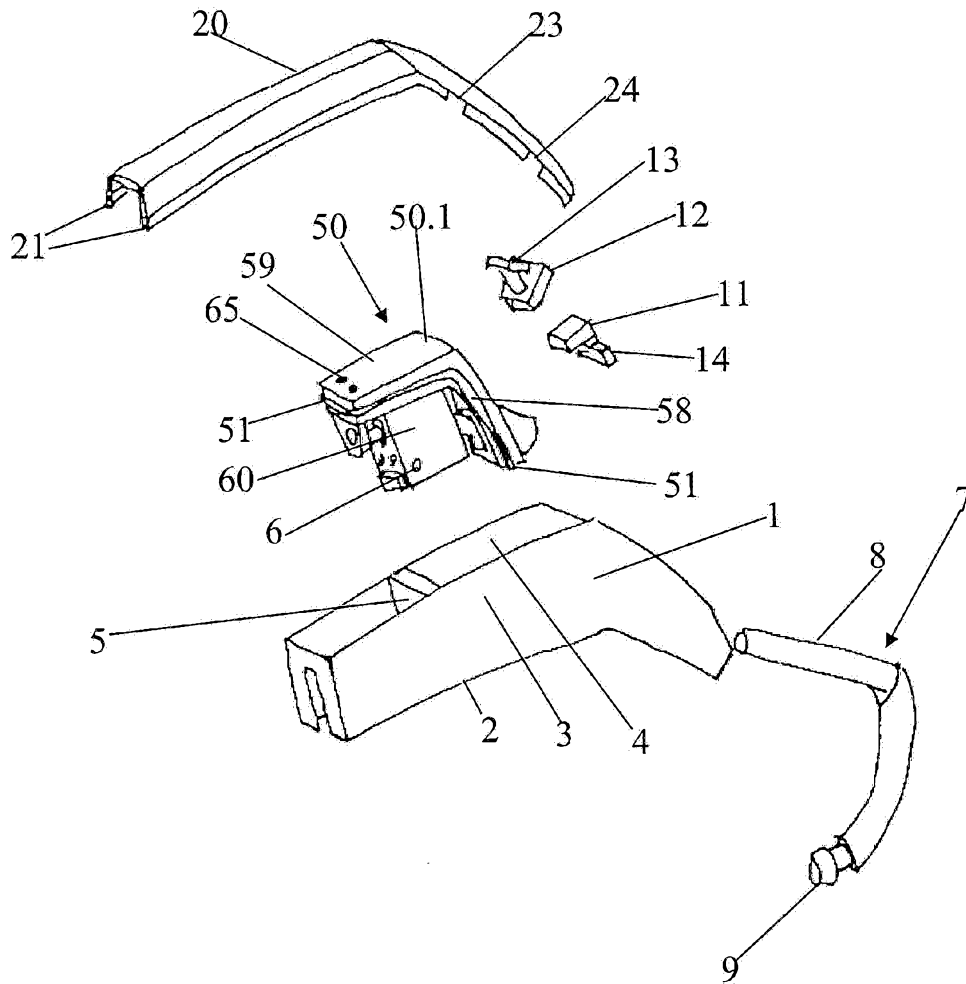

Fig. 1

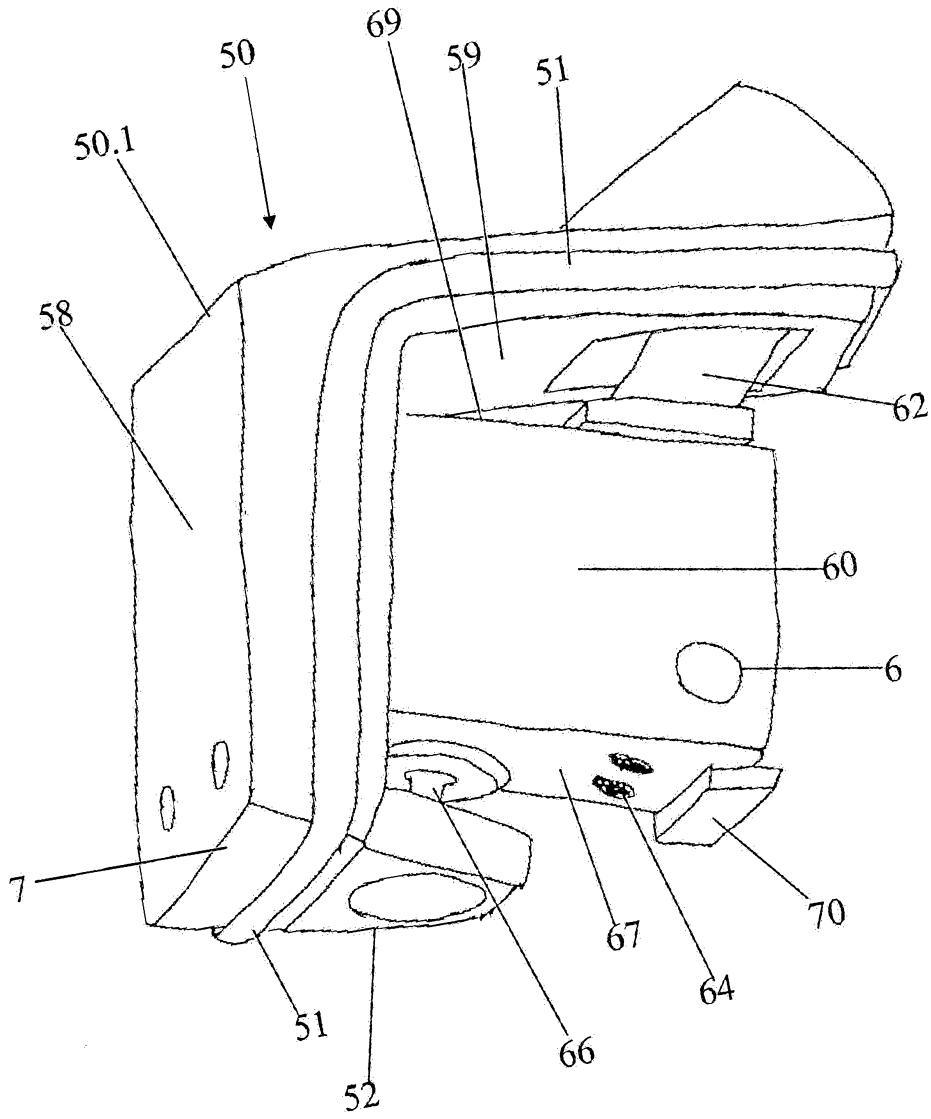

Fig. 2

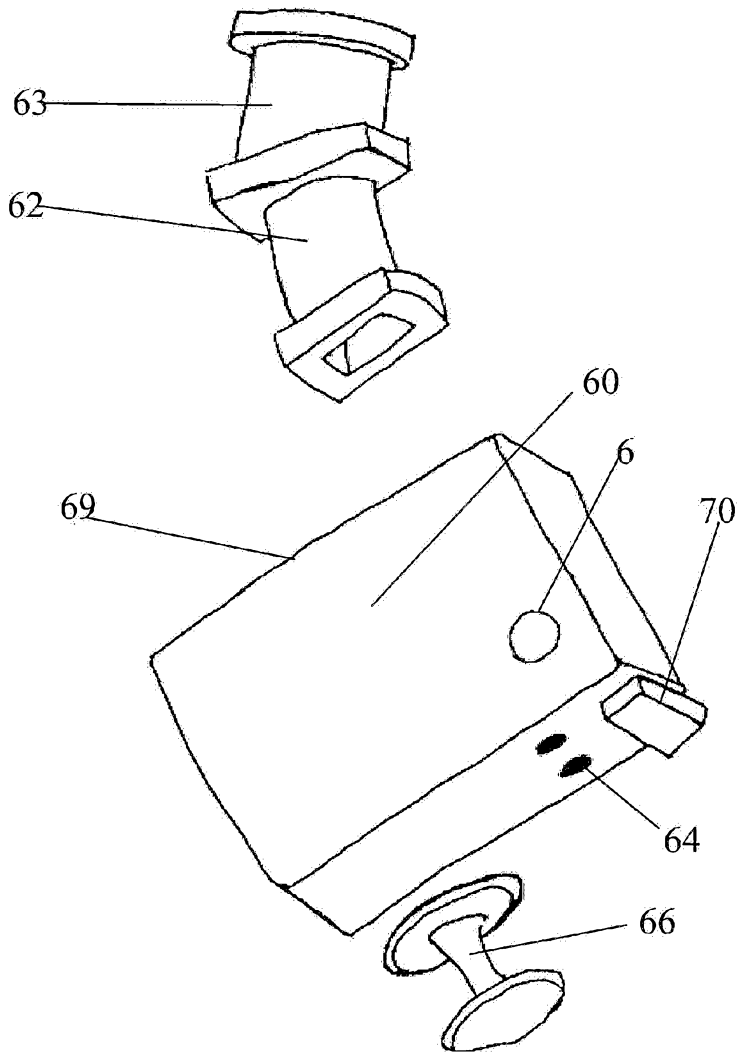

Fig. 3

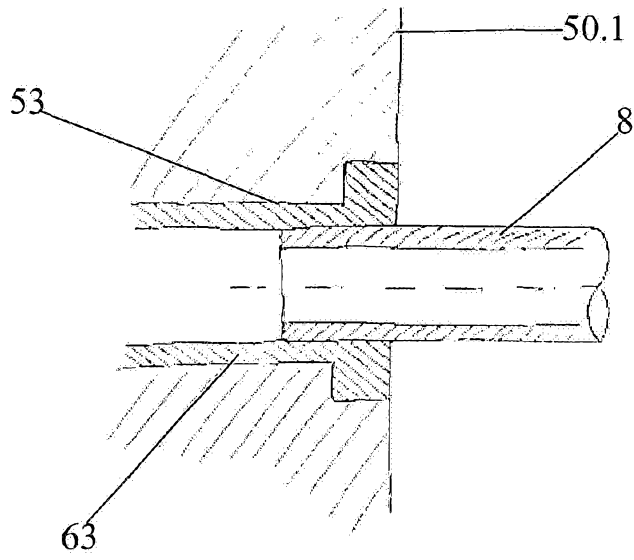

Fig. 4