

(19)



(11)

**EP 2 011 399 A1**

(12)

**EUROPEAN PATENT APPLICATION**

(43) Date of publication:  
**07.01.2009 Bulletin 2009/02**

(51) Int Cl.:  
**A21B 3/02<sup>(2006.01)</sup> F24C 15/04<sup>(2006.01)</sup>**

(21) Application number: **07012904.4**

(22) Date of filing: **02.07.2007**

(84) Designated Contracting States:  
**AT BE BG CH CY CZ DE DK EE ES FI FR GB GR HU IE IS IT LI LT LU LV MC MT NL PL PT RO SE SI SK TR**  
 Designated Extension States:  
**AL BA HR MK RS**

(71) Applicant: **Electrolux Home Products Corporation N.V.**  
**1930 Zaventem (BE)**

(72) Inventor: **Dalvander, Göran**  
**59151 Motala (SE)**

(74) Representative: **Schröer, Gernot H. et al**  
**Patentanwälte Meissner, Bolte & Partner**  
**Bankgasse 3**  
**90402 Nürnberg (DE)**

(54) **An oven door with a door frame and a door panel**

(57) The invention relates to an oven door including at least one door frame (10) and at least one door panel (12). The door panel (12) is integrated within the door frame (10). The door frame (10) grips directly an outer portion of at least one door panel (12) on three circum-

ferential sides of said door panel (12). The door frame (10) is formed as a one-piece injection moulded part made of a temperature-resistant material. The door panel (12) is made of a temperature-resistant material and at least partially of a transparent material. Further, the invention relates to a method for producing said oven door.

Fig. 2

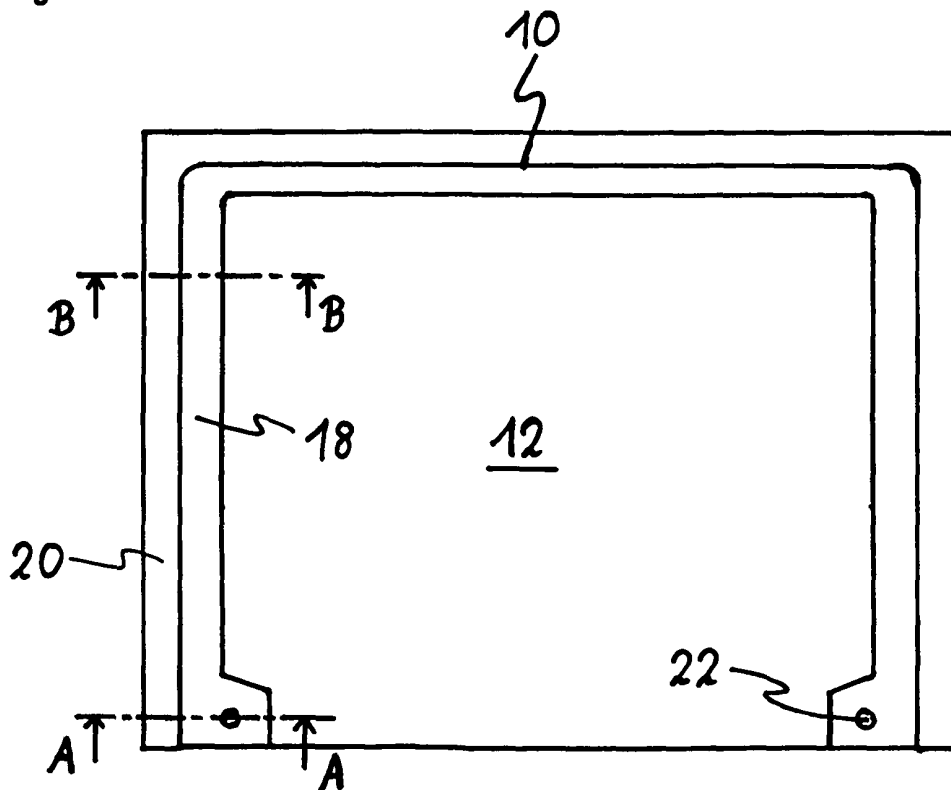

EP 2 011 399 A1

## Description

**[0001]** The present invention relates to an oven door according to claim 1. Further, the present invention relates to a method for producing an oven door according to claim 11.

**[0002]** An oven requires a window in the oven door, so that the user is able to look inside the oven without opening the oven door. The oven door further should be made of temperature-resistant materials.

**[0003]** Known oven doors consist usually of several parts. A typical oven door comprises one or more transparent door panels, which are made of glass or transparent plastics. The door panel is integrated in a door frame. Usually the door frame consists of several frame parts and each frame part is provided for one circumferential side of the door panel.

**[0004]** The production of such an oven door is very complex and generates high costs. The frame parts have to be put together to the door frame. This requires several working steps. Additionally the door panel must be inserted into the door frame before or after putting together the door frame.

**[0005]** DE 10 2004 002 470 A1 discloses an oven door with a door frame. The door frame includes an injection moulded part enclosing all four circumferential sides of a door panel. In order to attach a further door panel, additional fixing elements are required. The oven door cannot be completely disassembled without destroying the door frame.

**[0006]** DE 102 02 144 A1 discloses an oven door with a door frame enclosing all four circumferential sides of a door panel. The door frame includes also an injection moulded part. Further door panels must be glued onto the outer side of the door frames.

**[0007]** It is an object of the present invention to provide an oven door and a method for producing the oven door, which allow a simple and cheap production.

**[0008]** This object is achieved by the oven door according to claim 1.

**[0009]** According to the present invention the oven door includes at least one door frame and at least one door panel, wherein

- the door panel is integrated within the door frame,
- the door frame grips directly an outer portion of at least one door panel on three circumferential sides of said door panel,
- the door frame is formed as a one-piece injection moulded part made of a temperature-resistant material, and
- the door panel is made of a temperature-resistant material and at least partially of a transparent material.

**[0010]** The core idea of the present invention is on the one hand, that the door frame is formed as the one-piece injection moulded part, and on the other hand, that the

door frame grips directly the outer portion of the door panel on three circumferential sides. This allows a reduced production process by using the injection moulding. The door frame is produced around the door panel by a single step. The door panel is fixed within the door frame by the same single step. Thus, the door frame and the door panel form a compact unit. By the injection moulding it is not necessary to make any glue operation in order to fix together the door frame and the door panel.

**[0011]** In a preferred embodiment of the present invention the door panel comprises at least one hole in the outer portion of the door panel, wherein the hole is penetrated or filled by material of the injection moulded part. The hole or the holes, respectively, allow an additional fastening between the door frame and the door panel.

**[0012]** In particular, the hole is arranged in a corner of the door panel. This allows a big area for a window integrated within the oven door. Preferably the door panel is formed as a substantially rectangular sheet.

**[0013]** In the preferred embodiment of the present invention the door frame has a U-shaped form and grips the outer portion of the door panel on three circumferential sides of said door panel with said U-shaped form. This structure allows a simple production process, in particular for the step of injection moulding. Further, the door panel can be separated in an easy way from the door frame by moving the door panel through the open side of the U-shaped door frame at a later time.

**[0014]** At each end portion of the U-shaped door frame at least one of the holes may be arranged in the door panel. The holes in this position increase the stability of the oven door.

**[0015]** In an alternative embodiment of the present invention the door panel grips the outer portion of the door panel on each circumferential side of said door panel. In this case the door frame is a closed frame around the door panel. In this embodiment the hole or the holes, respectively, in the door panel are optional.

**[0016]** In the preferred embodiment of the present invention the door panel is made of glass.

**[0017]** Alternatively, the door panel may be made of transparent plastics. In this case the oven door has a very low weight.

**[0018]** For example, the door frame is formed of a polymer material, preferably a single polymer material.

**[0019]** Further, the door frame may comprise at least one portion, which is formed as a profile part. The profile part allows a low weight and requires less material.

**[0020]** Preferably, the outer portion of the door frame is formed as one or more profile parts. This allows an arbitrary contour of the oven door.

**[0021]** In particular, the oven door is provided for a cooking oven, preferably for domestic use.

**[0022]** Further the door panel may comprise at least one shield grid in order to screen electromagnetic waves. Thus, the oven door also may be provided for a microwave oven.

**[0023]** In order to guarantee the screening the electro-

magnetic waves it may be provided, that the door panel covers the cross-section of the inner space of the microwave oven.

**[0024]** The object of the present invention is further achieved by the method according to claim 11.

**[0025]** The inventive method for producing an oven door with at least one door frame and at least one door panel includes the following steps:

- providing the door panel made of a temperature-resistant material and at least partially of a transparent material, and
- injection moulding of the door frame along three circumferential sides of the door panel, so that the door frame grips directly least a part of the outer portion of the door panel.

**[0026]** This method allows a reduced production process by using the injection moulding. The door frame is produced around the door panel by a single step. The door panel is fixed within the door frame by the same single step. Thus, the door frame and the door panel form a compact unit.

**[0027]** In particular, the method is provided for producing the oven door described above.

**[0028]** The novel and inventive features believed to be the characteristic of the present invention are set forth in the appended claims.

**[0029]** The invention will be described in further detail with reference to the drawing, in which

FIG 1 illustrates a schematic front view of a door panel for an oven door according to a preferred embodiment of the present invention,

FIG 2 illustrates a schematic front view the an oven door according to the preferred embodiment of the present invention,

FIG 3 illustrates a section view A-A of the oven door according to the preferred embodiment of the present invention,

FIG 4 illustrates a section view B-B of the oven door according to the preferred embodiment of the present invention,

FIG 5 illustrates a perspective view of the oven door according to a further embodiment of the present invention, and

FIG 6 illustrates a perspective view of the oven door in FIG. 5 from the opposite side according to the further embodiment of the present invention.

**[0030]** FIG 1 illustrates a door panel 12 for the oven door according to a preferred embodiment of the present

invention. The door panel 12 has a substantially rectangular form. In this example the door panel 12 is made of glass. Alternatively, the door panel 12 can be made of other temperature-resistant and transparent materials. For example, the door panel is made of transparent plastics.

**[0031]** The door panel 12 comprises two holes 14. The holes 14 are arranged in two neighbouring corners of the door panel 12. In this embodiment the holes 14 have a diameter of about 10 mm.

**[0032]** FIG 2 illustrates a front view of an oven door according to the preferred embodiment of the present invention. The oven door comprises the door panel 12 according to FIG. 1 and a door frame 10. The door frame 10 is formed as a one-piece injection moulded part. The material of the door frame 10 is temperature-resistant. For example, the door frame 10 is formed of a polymer material. Preferably, the door frame 10 is formed of a single polymer material.

**[0033]** The door frame comprises an inner portion 18 and an outer portion 20. The inner portion 18 grips the door panel 12. The outer portion 20 is formed as a profile part. The door frame 10 with the profile part allows a low weight and requires less material than a massive door frame.

**[0034]** The door frame 10 is U-shaped and borders three sides of the door panel 12. The holes 14 of the door panel 12 are partially filled with the material of the door frame 10. Within each of the holes 14 is a clearance hole 22 in the inner part 18 of the door frame 10.

**[0035]** FIG 3 illustrates a section view A-A of the oven door according to the preferred embodiment of the present invention. The section view A-A relates to the corner of the door frame 10. FIG. 3 shows how the inner portion 18 of the door frame 10 grips the door panel 12. The outer portion 20 is formed as the profile part. Additionally, the outer portion 20 may comprise one or more hollow-profile parts.

**[0036]** FIG 3 shows further, how the holes 14 of the door panel 12 are partially filled with the material of the door frame 10. The clearance hole 22 is arranged coaxially to the hole 14 of the door panel 12.

**[0037]** FIG 4 illustrates a section view B-B of the oven door according to the preferred embodiment of the present invention. The section view B-B represents the cross-section of the bigger part of the door frame 10. The inner portion 18 of the door frame 10 grips three circumferential sides of the door panel 12. The outer portion 20 is formed as the profile part.

**[0038]** The structure of the oven door according to the present invention allows a reduced production process by using the injection moulding. The door frame 10 is produced around the door panel 12 by a single step. The door panel 12 is fixed within the door frame by the same single step. The door frame 10 and the door panel 12 form a compact unit. It is not necessary to make any glue operation in order to fix together the door frame and the door panel.

**[0039]** The oven door according to the present invention may include further door panels 12. The further door panels 12 may be fixed either in the same way as described above or in another suitable way.

**[0040]** FIG 5 illustrates a perspective view of the oven door 10 according to a further embodiment of the present invention. The oven door 10 according to the further embodiment includes also the door frame 10 and the door panel 12. The door frame 10 encloses three circumferential sides of the door panel 12. In each of the lower corners of the door panel 12 is one hole 14, which is at least partially filled with the material of the door frame 10.

**[0041]** The outer portion 20 of the door frame 10 includes two profile parts 24 on two opposite sides of said door frame 10. In this example the profile parts 24 are an integrated part of the vertical portions of the door frame 10. The profile parts 24 are provided for supporting one or more further door panels.

**[0042]** FIG 6 illustrates a perspective view of the oven door 10 of FIG 5 from the opposite side according to the further embodiment of the present invention. FIG. 6 shows partially the profile parts 24 from the inner side.

**[0043]** For special applications the door panel 12 may comprise one or more additional layers. If the oven door is provided for a microwave oven, then the door panel 12 may comprise a layer formed as a shield grid in order to screen the electromagnetic waves.

**[0044]** Although illustrative embodiments of the present invention have been described herein with reference to the accompanying drawing, it is to be understood that the present invention is not limited to those precise embodiments, and that various other changes and modifications may be affected therein by one skilled in the art without departing from the scope or spirit of the invention. All such changes and modifications are intended to be included within the scope of the invention as defined by the appended claims.

#### List of reference numerals

#### [0045]

10	door frame
12	door panel
14	hole
18	inner portion
20	outer portion
22	clearance hole
24	profile part

#### Claims

1. An oven door including at least one door frame (10) and at least one door panel (12), wherein
  - the door panel (12) is integrated within the door frame (10),

- the door frame (10) grips directly an outer portion of at least one door panel (12) on three circumferential sides of said door panel (12),
- the door frame (10) is formed as a one-piece injection moulded part made of a temperature-resistant material, and
- the door panel (12) is made of a temperature-resistant material and at least partially of a transparent material.

2. The oven door according to claim 1, **characterized in, that** the door panel (12) comprises at least one hole (14) in the outer portion of the door panel (12), wherein the hole (14) is penetrated or filled by material (16) of the injection moulded part, wherein preferably the hole (14) is arranged in a corner of the door panel (12).
3. The oven door according to claim 1 or 2, **characterized in, that** the door panel (12) is formed as a substantially rectangular sheet.
4. The oven door according to claim 3, **characterized in, that** the door frame (10) has an U-shaped form and grips the outer portion of the door panel (12) on three circumferential sides of said door panel (12) with said U-shaped form, wherein preferably at each end portion of the U-shaped door frame (10) at least one of the holes (14) is arranged in the door panel (12).
5. The oven door according to any one of the claims 1 to 3, **characterized in, that** the door panel (12) grips the outer portion of the door panel (12) on each circumferential side of said door panel (12).
6. The oven door according to any one of the preceding claims, **characterized in, that** the door panel (12) is made of glass or transparent plastics and/or that the door frame (10) is formed of a polymer material, in particular a thermoplastic material and/or a single polymer material.
7. The oven door according to any one of the preceding claims, **characterized in, that** the door frame (10) comprises at least one portion, which is formed as a profile part (18).
8. The oven door according to claim 7, **characterized in, that** the outer portion of the door frame (10) is formed as one or more profile parts (18).

9. The oven door according to any one of the preceding claims,  
**characterized in, that**  
the oven door is provided for a cooking oven, preferably for domestic use. 5
10. The oven door according to any one of the preceding claims,  
**characterized in, that**  
the door panel (12) comprises at least one shield grid in order to screen electromagnetic waves and/or that the oven door is provided for a microwave oven, wherein preferably the door panel (12) covers the cross-section of the inner space of the microwave oven. 10  
15
11. A method for producing an oven door with at least one door frame (10) and at least one door panel (12), wherein said method includes the following steps: 20
- providing the door panel (12) made of a temperature-resistant material and at least partially of a transparent material, and
  - injection moulding of the door frame (10) along three circumferential sides of the door panel (10), so that the door frame (10) grips directly at least partially the outer portion of the door panel (12). 25
12. The method according to claim 11, 30  
**characterized in, that**  
the method is provided for producing an oven door according to any one of the claims 1 to 10.

35

40

45

50

55

Fig. 1

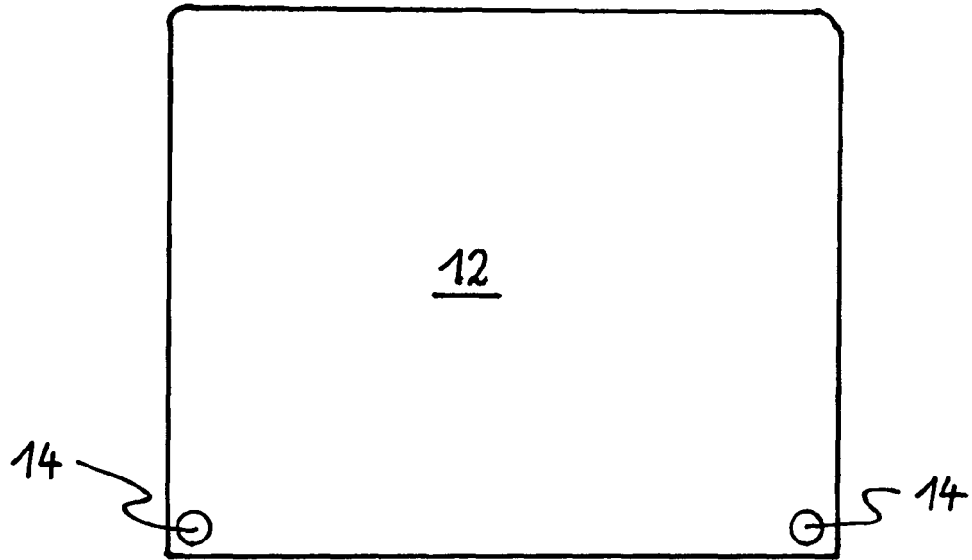

Fig. 2

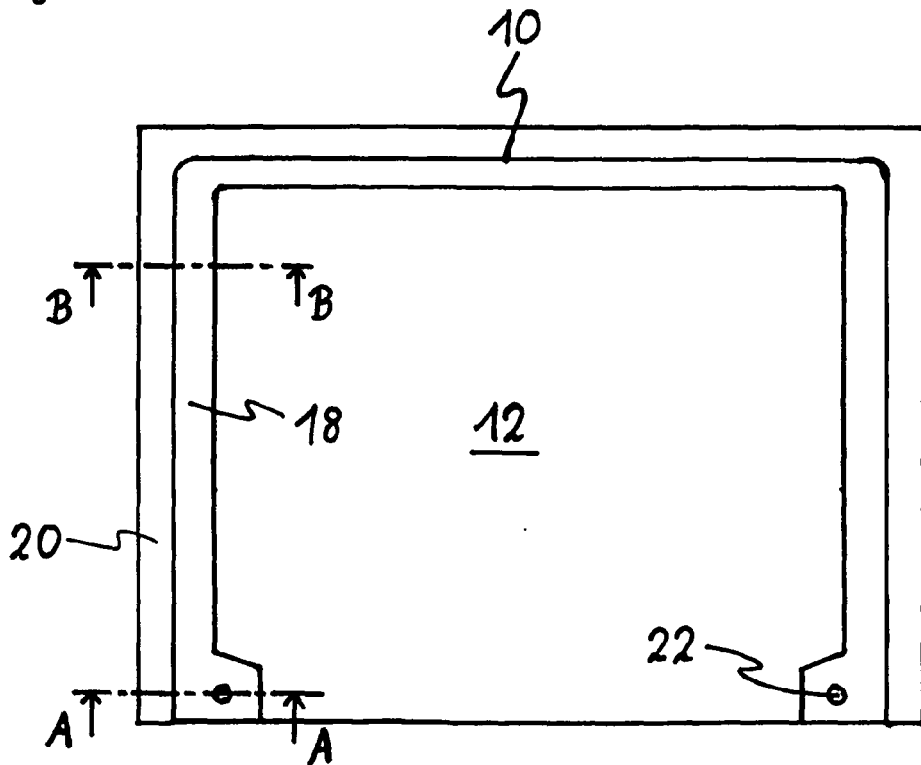

Fig. 3

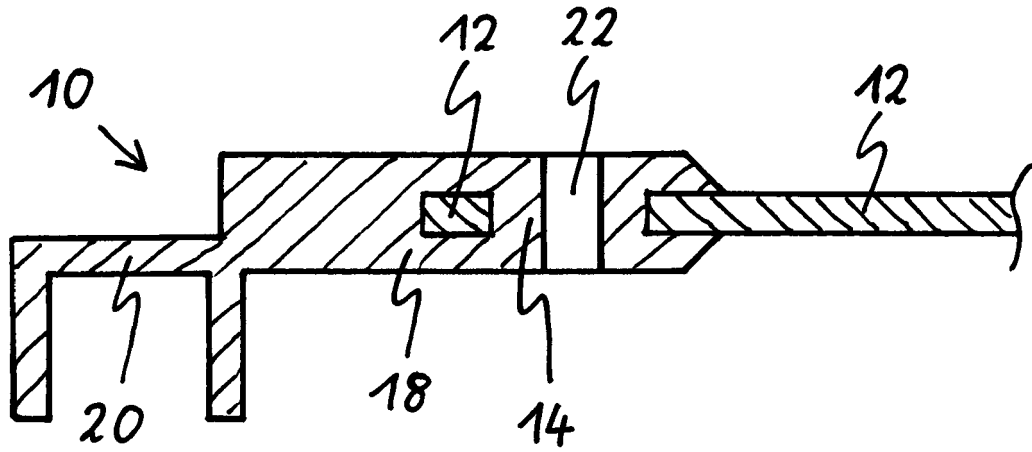

Fig. 4

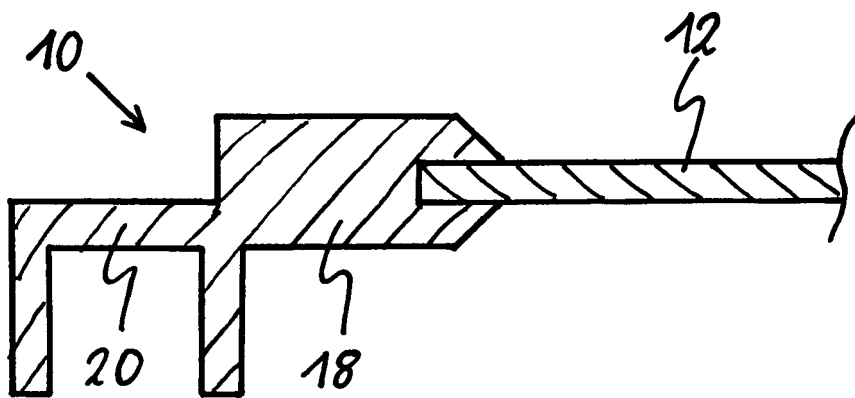

Fig. 5

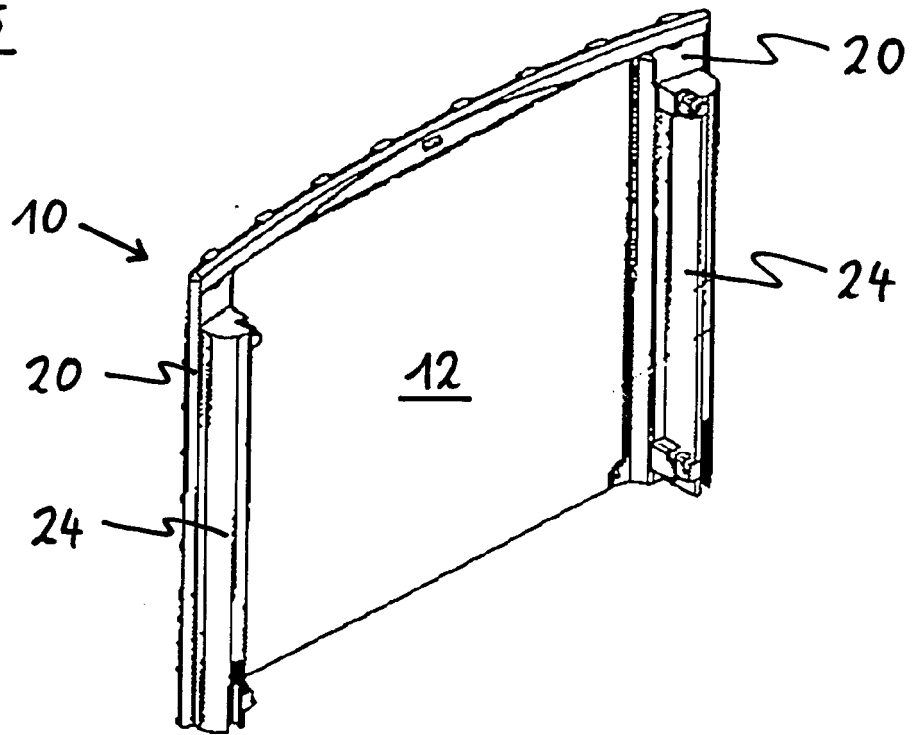
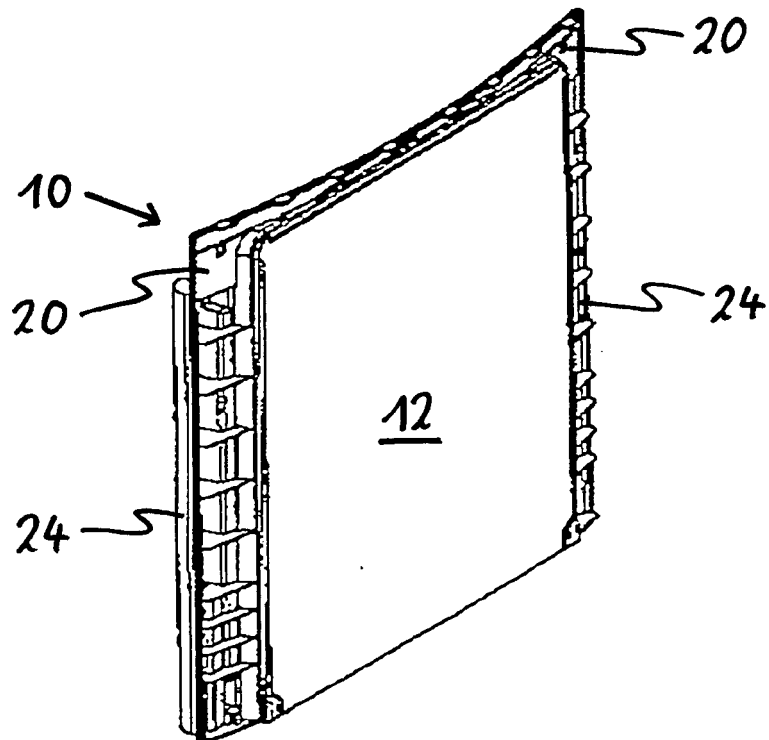

Fig. 6





DOCUMENTS CONSIDERED TO BE RELEVANT			
Category	Citation of document with indication, where appropriate, of relevant passages	Relevant to claim	CLASSIFICATION OF THE APPLICATION (IPC)
X	EP 0 919 361 A (GEMTRON CORP [US] GEMTRON CORP) 2 June 1999 (1999-06-02)	1,3,5-9, 11,12	INV. A21B3/02 F24C15/04
Y	* paragraph [0006]; figure 1 *	2,4	
X	US 5 789 724 A (LERSSEN BEN D [US] ET AL) 4 August 1998 (1998-08-04) * page 3, lines 27,28 - page 4, lines 22-26 * * page 5, paragraph 6 - page 6, paragraph 1 *	1,3,7-10	
X	DE 102 43 552 A1 (BSH BOSCH SIEMENS HAUSGERAETE [DE]) 1 April 2004 (2004-04-01)	1,3,5, 7-9	
Y	* paragraphs [0022], [0033], [0034], [0036]; figure 1 *	6,11,12	
Y	US 5 676 894 A (SPECHT PAUL [US]) 14 October 1997 (1997-10-14) * column 3, paragraph 1 *	2,4	
Y	US 2004/253471 A1 (THIEL JAMES P [US] ET AL) 16 December 2004 (2004-12-16) * page 6, paragraph 53 *	6	TECHNICAL FIELDS SEARCHED (IPC)
Y	EP 1 106 932 A (AEG HAUSGERAETE GMBH [DE]) 13 June 2001 (2001-06-13) * column 10, lines 17-24; figure 3 *	11,12	F24C A21B
The present search report has been drawn up for all claims			
Place of search		Date of completion of the search	Examiner
The Hague		7 December 2007	Rodriguez, Alexander
CATEGORY OF CITED DOCUMENTS			
X : particularly relevant if taken alone		T : theory or principle underlying the invention	
Y : particularly relevant if combined with another document of the same category		E : earlier patent document, but published on, or after the filing date	
A : technological background		D : document cited in the application	
O : non-written disclosure		L : document cited for other reasons	
P : intermediate document		& : member of the same patent family, corresponding document	

2  
EPO FORM 1503 03.82 (P04C01)

**ANNEX TO THE EUROPEAN SEARCH REPORT  
ON EUROPEAN PATENT APPLICATION NO.**

EP 07 01 2904

This annex lists the patent family members relating to the patent documents cited in the above-mentioned European search report. The members are as contained in the European Patent Office EDP file on  
The European Patent Office is in no way liable for these particulars which are merely given for the purpose of information.

07-12-2007

Patent document cited in search report	Publication date	Patent family member(s)	Publication date
EP 0919361	A	02-06-1999	CA 2254660 A1 01-06-1999
			DE 69811184 D1 13-03-2003
			DE 69811184 T2 27-11-2003
			ES 2192734 T3 16-10-2003
			US 6210618 B1 03-04-2001
-----			
US 5789724	A	04-08-1998	NONE
-----			
DE 10243552	A1	01-04-2004	NONE
-----			
US 5676894	A	14-10-1997	AU 2650995 A 04-01-1996
			CA 2191839 A1 14-12-1995
			EP 0781192 A1 02-07-1997
			WO 9533614 A1 14-12-1995
			US 5527500 A 18-06-1996
			US 5661944 A 02-09-1997
			US 5593706 A 14-01-1997
-----			
US 2004253471	A1	16-12-2004	US 2007275253 A1 29-11-2007
-----			
EP 1106932	A	13-06-2001	NONE
-----			

EPO FORM P0459

For more details about this annex : see Official Journal of the European Patent Office, No. 12/82

**REFERENCES CITED IN THE DESCRIPTION**

*This list of references cited by the applicant is for the reader's convenience only. It does not form part of the European patent document. Even though great care has been taken in compiling the references, errors or omissions cannot be excluded and the EPO disclaims all liability in this regard.*

**Patent documents cited in the description**

- DE 102004002470 A1 **[0005]**
- DE 10202144 A1 **[0006]**