



(51) International Patent Classification:

*B65D 71/12* (2006.01)    *B65D 71/30* (2006.01)  
*B65D 71/20* (2006.01)    *B65D 71/36* (2006.01)

(21) International Application Number:

PCT/US2015/021423

(22) International Filing Date:

19 March 2015 (19.03.2015)

(25) Filing Language:

English

(26) Publication Language:

English

(30) Priority Data:

61/967,594    21 March 2014 (21.03.2014)    US

(71) Applicant: **GRAPHIC PACKAGING INTERNATIONAL, INC.** [US/US]; Law Department - 9th Floor, 1500 Riveredge Parkway, Suite 100, Atlanta, GA 30328 (US).

(72) Inventor: **THOMPSON, Jon**; 172 Earlstone Crescent, Cadbury Heath, Bristol BS30 8AJ (GB).

(74) Agent: **CLAERBOUT, Andrew, N.**; Womble Carlyle Sandridge & Rice LLP, P.O. Box 7037, Atlanta, GA 30357-0037 (US).

(81) Designated States (unless otherwise indicated, for every kind of national protection available):

AE, AG, AL, AM, AO, AT, AU, AZ, BA, BB, BG, BH, BN, BR, BW, BY, BZ, CA, CH, CL, CN, CO, CR, CU, CZ, DE, DK, DM, DO, DZ, EC, EE, EG, ES, FI, GB, GD, GE, GH, GM, GT, HN, HR, HU, ID, IL, IN, IR, IS, JP, KE, KG, KN, KP, KR, KZ, LA, LC, LK, LR, LS, LU, LY, MA, MD, ME, MG, MK, MN, MW, MX, MY, MZ, NA, NG, NI, NO, NZ, OM, PA, PE, PG, PH, PL, PT, QA, RO, RS, RU, RW, SA, SC, SD, SE, SG, SK, SL, SM, ST, SV, SY, TH, TJ, TM, TN, TR, TT, TZ, UA, UG, US, UZ, VC, VN, ZA, ZM, ZW.

(84) Designated States (unless otherwise indicated, for every kind of regional protection available):

ARIPO (BW, GH, GM, KE, LR, LS, MW, MZ, NA, RW, SD, SL, ST, SZ, TZ, UG, ZM, ZW), Eurasian (AM, AZ, BY, KG, KZ, RU, TJ, TM), European (AL, AT, BE, BG, CH, CY, CZ, DE, DK, EE, ES, FI, FR, GB, GR, HR, HU, IE, IS, IT, LT, LU, LV, MC, MK, MT, NL, NO, PL, PT, RO, RS, SE, SI, SK, SM, TR), OAPI (BF, BJ, CF, CG, CI, CM, GA, GN, GQ, GW, KM, ML, MR, NE, SN, TD, TG).

[Continued on next page]

(54) Title: CARTON FOR CONTAINERS

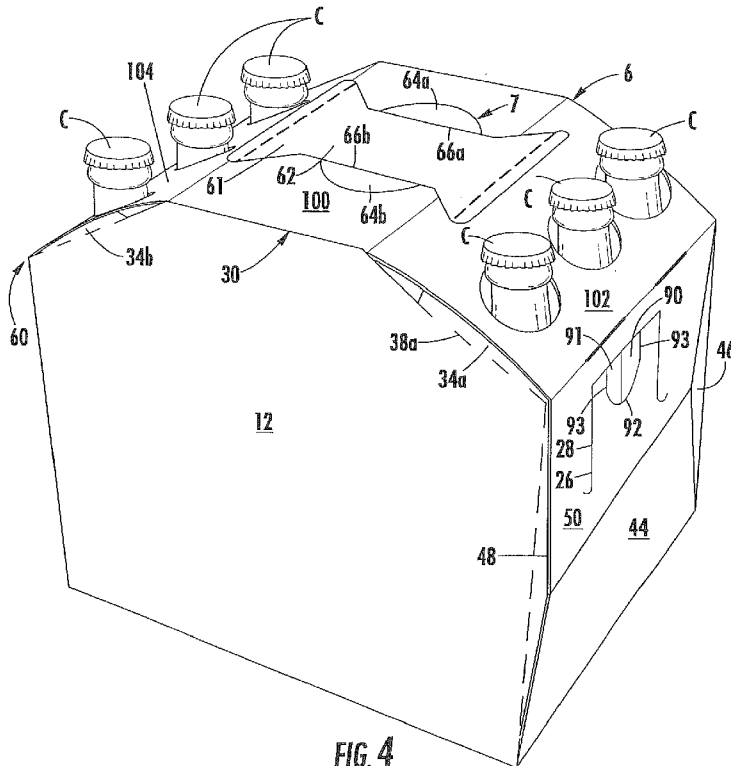

(57) Abstract: A carton for containing a plurality of articles. The carton includes a plurality of panels that extends at least partially around an interior of the carton. The plurality of panels includes a top panel, a bottom panel, and at least one side panel foldably connected to the top panel. At least one end flap is foldably connected to at least one panel of the plurality of panels. The at least one end flap at least partially closes an end of the carton. The top panel includes a first portion foldably connected to a second portion at a fold line. The second portion is positioned at an oblique angle relative to the first portion and configured to receive at least a portion of at least one of the plurality of articles. At least one of the plurality of articles extends through the second portion.

WO 2015/143128 A1

**Declarations under Rule 4.17:**

- *as to applicant's entitlement to apply for and be granted a patent (Rule 4.17(ii))*
- *as to the applicant's entitlement to claim the priority of the earlier application (Rule 4.17(iii))*

**Published:**

- *with international search report (Art. 21(3))*

**CARTON FOR CONTAINERS**CROSS-REFERENCE TO RELATED APPLICATION

[0001] This application claims the benefit of U.S. Provisional Patent Application No. 61/967,594, filed March 21, 2014.

INCORPORATION BY REFERENCE

[0002] The disclosure of U.S. Provisional Patent Application No. 61/967,594, which was filed on March 21, 2014, is hereby incorporated by reference for all purposes as if presented herein in its entirety.

BACKGROUND

[0003] The present disclosure generally relates to carriers or cartons for holding containers. More specifically, the present disclosure relates to a carrier having article displaying features.

SUMMARY

[0004] In one aspect, the disclosure is generally directed to a carton for containing a plurality of articles. The carton comprises a plurality of panels that extends at least partially around an interior of the carton. The plurality of panels comprises a top panel, a bottom panel, and at least one side panel foldably connected to the top panel. At least one end flap is foldably connected to at least one panel of the plurality of panels. The at least one end flap at least partially closes an end of the carton. The top panel comprises a first portion foldably connected to a second portion at a fold line. The second portion is positioned at an oblique angle relative to the first portion and configured to receive at least a portion of at least one of the plurality of articles. At least one of the plurality of articles extends through the second portion.

[0005] In another aspect, the disclosure is generally directed to a blank for forming a carton for containing a plurality of articles. The blank comprises a plurality of panels. The plurality of panels comprises a top panel, a bottom panel, and at least one side panel foldably connected to the top panel. At least one end flap is foldably connected to at least one panel of the plurality of panels. The at least one end flap is for at least partially closing an end of the carton when the carton is formed from the blank. The top panel comprises a first portion foldably connected to a second portion at a fold line. The second portion is positionable at an oblique angle relative to the first portion and configured to receive at least a portion of at least one of the plurality of articles when the carton is formed from the blank. At least one of the plurality of articles extends through the second portion when the carton is formed from the blank.

[0006] In another aspect, the disclosure is generally directed to a method of forming a carton for containing a plurality of articles. The method comprises obtaining a blank comprising a plurality of panels. The plurality of panels comprises a top panel, a bottom panel, and at least one side panel foldably connected to the top panel. At least one end flap is foldably connected to at least one panel of the plurality of panels. The top panel comprises a first portion foldably connected to a second portion at a fold line. The method further comprises forming an interior of the carton at least partially defined by the plurality of panels. The forming of the interior of the carton comprises forming an open-ended sleeve. The method further comprises positioning the second portion at an oblique angle relative to the first portion and extending at least one of the plurality of articles through the second portion.

[0007] Those skilled in the art will appreciate the above stated advantages and other advantages and benefits of various additional embodiments reading the following detailed description of the embodiments with reference to the below-listed drawing figures. It is within the scope of the present disclosure that the above-discussed aspects be provided both individually and in various combinations.

#### BRIEF DESCRIPTION OF THE DRAWINGS

[0008] According to common practice, the various features of the drawings discussed below are not necessarily drawn to scale. Dimensions of various features and elements in the drawings may be expanded or reduced to more clearly illustrate the embodiments of the disclosure.

[0009] Fig. 1 is an exterior plan view of a blank for forming a carton according to a first embodiment of the disclosure.

[0010] Fig. 2 is a perspective view of a sleeve formed from the blank of Fig. 1.

[0011] Fig. 3 is a perspective view of a partially closed carton of the first embodiment.

[0012] Fig. 4 is a perspective view of a carton formed from the blank of Fig. 1.

[0013] Fig. 5 is a side view of the carton of Fig. 4.

[0014] Fig. 6 is a perspective view of the carton of Fig. 4 showing the activation of a handle.

[0015] Fig. 7 is an exterior plan view of a blank for forming a carton according to a second embodiment of the disclosure.

[0016] Fig. 8 is a perspective view of a carton formed from the blank of Fig. 7 according to the second embodiment of the disclosure.

- [0017] Fig. 9 is a side perspective view of the carton of Fig. 8.
- [0018] Fig. 10 is a front perspective view of the carton of Fig. 8.
- [0019] Corresponding parts are designated by corresponding reference numbers throughout the drawings.

#### DETAILED DESCRIPTION OF THE EXEMPLARY EMBODIMENTS

- [0020] The present disclosure generally relates to cartons for containing articles such as containers, bottles, cans, etc. The articles can be used for packaging food and beverage products, for example. The articles can be made from materials suitable in composition for packaging the particular food or beverage item, and the materials include, but are not limited to, glass; aluminum and/or other metals; plastics such as PET, LDPE, LLDPE, HDPE, PP, PS, PVC, EVOH, and Nylon; and the like, or any combination thereof.
- [0021] Cartons according to the present disclosure can accommodate articles of any shape. For the purpose of illustration and not for the purpose of limiting the scope of the disclosure, the following detailed description describes beverage containers (e.g., glass, plastic, or metal beverage bottles) as disposed within the carton embodiments. In this specification, the terms “lower,” “bottom,” “upper” and “top” indicate orientations determined in relation to fully erected and upright cartons.
- [0022] Fig. 1 is a plan view of the exterior side 2 of a blank, generally indicated at 4, used to form a carton 6 (Fig. 4) according to an exemplary embodiment of the disclosure. The carton 6 can be used to house a plurality of articles such as containers C (Fig. 3). The carton 6 has a handle, generally indicated at 7 (Fig. 6), for grasping and carrying the carton. In the illustrated embodiment, the carton 6 is sized to house twelve containers C in a single layer in a 3x4 arrangement, but it is understood that the carton may be sized and shaped to hold containers of a different or same quantity in more than one layer and/or in different row/column arrangements (e.g., 1x6, 3x6, 2x6, 4x6, 2x6x2, 3x4x2, 2x9, etc.). In the illustrated embodiment, the containers C are bottles, but other types of containers can be used in the carton 6.
- [0023] The blank 4 has a longitudinal axis L1 and a lateral axis L2. The blank 4 has a bottom panel 8 foldably connected to a first side panel 10 at a lateral fold line 14 and a second side panel 12 at a lateral fold line 16. An outer top panel 18 is foldably connected to the first side panel 10 at a lateral fold line 22. An inner top panel 20 is foldably connected to the second side panel 12 at a lateral fold line 24. In the embodiment, the outer and inner top panels 18, 20 are overlapped in the erected carton 6 to form a top wall 30 (Figs. 2-6).

[0024] In the illustrated embodiment, the first side panel 10 is foldably connected to two gusset panels (i.e., first and second gusset panels) 32a, 32b along respective oblique fold lines 36a, 36b and the second side panel 12 is foldably connected to two gusset panels (i.e., third and fourth gusset panels) 34a, 34b along respective oblique fold lines 38a, 38b. The outer top panel 18 is foldably connected to the first and second gusset panels 32a, 32b along at least a portion of fold line 22 and inner top panel 20 is foldably connected to the third and fourth gusset panels 34a, 34b along at least a portion of fold line 24. The first gusset panel 32a comprises first and second gusset portions 33a, 37a foldably connected along oblique fold line 40a. The second gusset panel 32b comprises third and fourth gusset portions 33b, 37b foldably connected along oblique fold line 40b. The third gusset panel 34a comprises fifth and sixth gusset portions 34a, 39a foldably connected along oblique fold line 42a. The fourth gusset panel 34b comprises seventh and eighth gusset portions 34a, 39a foldably connected along oblique fold line 42b. In one embodiment, the gusset panels 32a, 32b, 34a, 34b may include cutouts 43 at the end of the gusset panels 32a, 32b, 34a, 34b adjacent the outer top panel 18 and inner top panel 20, and respective first side panel 10 and second side panel 12, respectively.

[0025] According to an exemplary embodiment, as shown in Fig. 1, the bottom panel 8 is foldably connected to a first bottom end flap 44 and a second bottom end flap 45. The first side panel 10 is foldably connected to a first side end flap 46 and a second side end flap 47. The second side panel 12 is foldably connected to a first side end flap 48 and a second side end flap 49. The outer top panel 18 is foldably connected to a first top end flap 50 and a second top end flap 51. The inner top panel 20 is foldably connected to a third top end flap 52 and a fourth top end flap 53.

[0026] In one embodiment, the end flaps 44, 46, 48, 50, 52 extend along a first marginal area of the blank 4, and are foldably connected at a first longitudinal fold line 56 that extends along the length of the blank. The end flaps 45, 47, 49, 51, 53 extend along a second marginal area of the blank 4, and are foldably connected at a second longitudinal fold line 57 that also extends along the length of the blank. The longitudinal fold lines 56, 57 may be, for example, substantially straight, or oblique at one or more locations to account for blank thickness or for other factors. Additionally, portions of the longitudinal fold lines 56, 57 can be weakened areas, such as portions of the longitudinal fold lines 56, 57 that are overlapped by respective other portions of the longitudinal fold lines 56, 57. A weakened area can be two or more scores, creases, or other lines. For example, weakened areas 56a, 56b can be generally aligned with the first longitudinal fold line 56 and weakened areas 57a, 57b can be generally aligned with the second longitudinal fold line 57. When the carton 6 is erected, the end flaps 44, 46, 48, 50, 52 close a first end 59 of the carton, and the end flaps 45, 47, 49, 51, 53 close a second end 60 of the carton. In accordance with an alternative embodiment of the disclosure, different flap arrangements can be used for closing the ends 59, 60 of the carton 6.

[0027] According to one embodiment of the disclosure, the features that comprise the handle 7 (Fig. 2) include an outer handle panel 61 that is in the outer top panel 18. The outer handle panel 61 comprises a central portion 62 with two handle flaps 64a, 64b, each foldably connected at respective lateral fold lines 66a, 66b. As shown in Fig. 1, the ends of the outer handle panel 61 may be flanged or widened with respect to the central portion 62. The periphery of the outer handle panel 61 may be defined by a tear line 68 in the top panel 18, so that the outer handle panel 61 is detachable. In one embodiment the outer handle panel 61 may include lines of weakness 65 near the outer portions of the outer handle panel. The lines of weakness 65 may facilitate bending of the outer handle panel when the handle is activated by a user. The lines of weakness 65 could be otherwise shaped, arranged, positioned, and/or omitted without departing from the disclosure.

[0028] In one embodiment, the features that are for forming the handle 7 further comprise an inner handle panel 70 in the inner top panel 20, and an intermediate handle panel 72 in the inner top panel 20. The inner handle panel 70 has a central portion 71 foldably connected to a first end portion 74 and a second end portion 75 along respective fold lines 115a and 117a. Similarly, the intermediate handle panel 72 has a central portion 73 foldably connected to a third end portion 76 and a fourth end portion 77 along respective fold lines 115b and 117b. End flap 52 comprises a portion of end portions 74, 76 and end flap 53 comprises a portion of end portions 75, 77. In the illustrated embodiment, the central portions 71, 73 can be generally narrower than the respective end portions 74, 75 and 76, 77, and the narrowness can be provided as a result of portions of the inner top panel 20 having been cut out/removed. In one embodiment, the central portions 71, 73 are generally the same or have similar dimensional length and width as the central portion 62 of the outer handle panel 61. The inner handle panel 70 is foldably connected to the intermediate handle panel 72 at respective lateral fold lines 80, 81 that extend from the inner top panel 20 into respective end flaps 52, 53. The intermediate handle panel 73 is detachably connected to the inner top panel 20 and top end flaps 52, 53 at respective lateral tear lines 82, 83 that extend from the inner top panel 20 into respective end flaps 52, 53. Article-receiving features of the handle 7 include respective openings 86, 87 at respective end portions 74, 75 of the inner handle panel 70 and openings 88, 89 at respective end portions 76, 77 of the intermediate handle panel 72.

[0029] In the illustrated embodiment, the features that are for forming the handle 7 further comprise handle flaps 26, 27 in the respective top end flaps 50, 51. The handle flaps 26, 27 are defined by a respective tear line 28, 29 in a respective top end flap 50, 51, and the handle flaps 26, 27 are spaced apart from a respective longitudinal fold line 56, 57 and the top panel 18. Portions of the tear lines 28, 29, or all of the tear lines 28, 29, can be replaced by a cut line without departing from the disclosure. The article-receiving features further include article-receiving flaps 90, 91 foldably connected to each of the handle flaps 26, 27. The flaps 90, 91 can be defined by cut lines 92 and fold lines 93 extending

to the respective tear lines 28, 29. The features that are for forming the handle 7 could be otherwise shaped, arranged, and positioned without departing from the disclosure.

[0030] In the illustrated embodiment, the blank 4 comprises features for displaying or showing one or more of the containers C through the carton 6. The outer top panel 18 comprises a central portion (i.e., first portion or stationary portion) 100, a first article display portion (i.e., second portion or first moveable portion) 102 foldably connected to and moveable with respect to the central portion 100 along a fold line 103, and a second article display portion (i.e., third portion or second moveable portion) 104 foldably connected to and moveable with respect to the central panel 100 along fold line 105. In one embodiment, the article display portions 102, 104 have three apertures 110 for receiving a portion of the containers (i.e., bottle necks) so that a portion of the containers extends from the interior of the carton and is visible to a consumer. The apertures 110 could be circular, round, oval, elliptic, ovate, otherwise shaped, arranged, and/or configured without departing from the disclosure.

[0031] As illustrated in Fig. 1, the inner top panel 20 comprises two apertures 112 that are configured to align (e.g., generally or substantially align) with the apertures 110 in the article display portions 102, 104 of outer top panel 18 to receive the containers C when the blank is formed into a carton. The necks of containers C extend through the apertures 110, 112 and are displayed through the carton 6. In one embodiment the inner top panel 20 may comprise apertures 120 located along fold lines 56, 57, however, apertures 120 could be otherwise shaped, arranged, configured and/or omitted without departing from the disclosure.

[0032] In one embodiment, the top panel 18 can be larger than the bottom panel 8 in the lateral direction L2 so that some or all of each the article display portions 102, 104 can be angled inwardly and substantially align with the respective side of the carton. The gusset panels 32a, 32b, 34a, 34b, angled fold lines 36, 38 and cutouts 43 facilitate forming of the carton 6 in a manner so that the article display portions 102, 104 conform to the angle A of the fold lines 36, 38. The angle A may range between 0 to 90 degrees, preferably between 5 and 45 degrees, and most preferably 30 degrees from fold lines 22, 24.

[0033] An exemplary method of forming the carton 6 is discussed in detail below. At various stages in the method for forming, respective portions of the blank 4 are mounted to one another in any suitable manner. For example, at various stages of the carton forming process, glue or other adhesive material can be applied at various portions of the blank 4. For example, the adhesive material may be present where appropriate surfaces of the blank are in face-to-face contact. Depending upon the amount and/or type of adhesive material or other fastening mechanisms used, each of the face-to-face contacts described in this disclosure may be more generally referred to as the respective features being in substantially face-to-face contact.

[0034] In one embodiment, the blank 4 is first positioned with the exterior surface 2 facing down. First the inner handle panel 70 is folded about fold lines 80, 81 so that the inner handle panel overlaps and is in face-to-face contact with the intermediate handle panel 72. Glue can be applied to portions of either the inner or intermediate handle panel 70, 72 to adhesively secure the inner and intermediate handle panels. When the inner and intermediate handle panels 70, 72 are overlapped, the openings 86, 88 in the respective end portions 74, 76 of the respective inner and intermediate handle panels 70, 72 are generally aligned and form an article-receiving opening, and the openings 83, 87 in the respective end portions 75, 77 of the respective inner and intermediate handle panels 70, 72 are generally aligned and form an article-receiving opening.

[0035] Subsequently, the blank 4 can be folded at the lateral fold line 24 to position the overlapped inner and intermediate handle panels 70, 72 to be in face-to-face contact with the side panel 12. Next, the blank 4 is further assembled by folding so that the outer top panel 18, overlaps the inner top panel 20 to form the top wall 30 (Fig. 2), and the partially erected carton is in the form of a flattened sleeve formation. In the flattened sleeve formation, the outer handle panel 61 of the outer top panel 18 is in face-to-face contact with a portion of the intermediate handle panel 72 that overlaps the inner handle panel 70. Also, the handle flap 26 is in face-to-face contact with a portion of the end portion 76 of the intermediate handle panel 72, and the handle flap 27 is in face-to-face contact with a portion of the end portion 77 of the intermediate handle panel 72. In one embodiment, the outer handle panel 61 is adhesively secured to the central portion 73 of the intermediate handle panel 72, the handle flap 26 is adhesively secured to the end portion 76 of the intermediate handle panel 72, and the handle flap 27 is adhesively secured to the end portion 77 of the intermediate handle panel 72. The article-receiving features can be generally overlapped so that a portion of the article receiving-opening (formed by overlapped openings 86, 88) is generally aligned with the article-receiving flaps 90, 91 in the handle flap 26 and a portion of the article-receiving opening (formed by overlapped openings 87, 89) is generally aligned with the article-receiving flaps 90, 91 in the handle flap 27 (Fig. 6).

[0036] The flattened sleeve formation can be erected into an open-ended sleeve, as illustrated in Fig. 2, so that products or containers C can be loaded into the erected sleeve. After loading the containers C, the ends 59, 60 of the carton can be closed by first inwardly folding gusset panels 32a, 32b, 34a, 34b along respective fold lines 40a, 40b, 42a, 42b such that gusset panels 33a, 37a; 33b, 37b; 35a, 39a; and 35b, 39b are in face-to-face contact and the display portions 102, 104 (e.g., second portion) are lowered relative to the central portion 100 (e.g., first portion) and a respective container extends through the apertures 110 as shown in Figs. 3-6. As shown in Figs. 5 and 6, the second portions 102, 104 are positioned at an oblique angle relative to the first portion 100. Next, each respective end can be closed by at least partially overlapping and adhering the end flaps 44, 46, 48, 50, 52 at one end of the carton and at least partially overlapping and adhering the end flaps 45, 47, 49, 51, 53 at the other

end of the carton. The overlapped top end flaps at each end (e.g., 50, 52 at end 59 and 51, 53 at end 60) are downwardly folded and secured to the bottom end flap (e.g., 44, 45) and side end flaps (46, 48 and 47, 49), respectively. The assembled carton 6 is shown in Fig. 4. The ends 67, 69 of the carton 6 could be closed by other closing steps and features without departing from the disclosure. Additionally, alternative closing and loading sequences may be used without departing from the disclosure. For example, the containers C can be loaded into the carton 6 after closing the first end 59 or the second end 60.

[0037] As shown in Fig. 6, the handle 7 is activated by separating the outer handle panel 61 from the outer top panel 18 by tearing the tear line 68 to form an opening 130 in the top wall 30 exposing the carton interior 132. The overlapped outer handle panel 61 and central portions 71, 73 of the inner and intermediate handle panels 70, 72 can be grasped and lifted upwardly. The handle flaps 64 can be folded downwardly to underlap the central portions 71, 73, 62 of the respective handle panels 70, 72, 61 when separating the outer handle panel 61 from the outer top panel 18. By upwardly lifting the outer handle panel 61 and overlapped central portions 71, 73, the overlapped handle flap 26 and end portions 74, 76 at one end 59 and the overlapped handle flap 27 and end portions 75, 77 at the other end 60 are caused to fold inwardly toward the interior of the carton 6.

[0038] In the illustrated embodiment, the handle 7 formed from the handle features of the blank comprises three layers of material (e.g., the outer handle panel 61, the central portion 73 of the intermediate handle panel 72, and the central portion 71 of the inner handle panel 70) in the top of the carton 6, three layers of material (e.g., the handle flap 26, the end portion 76 of the intermediate handle panel 72, and the end portion 74 of the inner handle panel 71) at the first end of the carton 59, and three layers of material (e.g., the handle flap 27, the end portion 77 of the intermediate handle panel 72, and the end portion 75 of inner handle panel 70) at the second end of the carton 60. The handle 7 could have other features and could include additional or fewer reinforcing layers or portions without departing from the disclosure.

[0039] It is noted that the handle 7 is formed in a manner that has end portions in the end 59, 60 of the carton 6 while keeping the corners of the carton at the ends 59, 60, intact and free from any portion of the handle. The handle flaps 26, 27 are spaced apart from the top wall 30 so that the handle 7 extends from the carton 6 without disrupting the interior 132.

[0040] As further illustrated in Fig. 6, the article flaps 90, 91 in each of the handle flaps 26, 27 and the openings 124, 126 in the overlapped inner and intermediate handle panels 70, 72, allow the handle 7 to conform to or accommodate the end container C that is adjacent a respective end 59, 60 of the carton 6 when the handle is lifted. One or more of the containers C adjacent or proximate the second end 60 can be received in the article-receiving opening 126 (the overlapped openings 87, 89 in the

respective end portions 75, 77 of the respective handle panels 71, 72) when the handle 7 is activated. The article-receiving opening 124 and article-receiving flaps 90, 91 of the handle flap 26 at the first end of the carton can conform to or accommodate a container C, as well as article-receiving opening 126 conforming to or accommodating a container C, upon lifting of the handle 7. Accordingly, the handle 7 can be lifted upwardly relative to the top wall 30 and the ends of the handle can move inwardly from the ends 59, 60 of the carton 6 while accommodating the products in the carton.

[0041] Fig. 7 is a plan view of another embodiment of the disclosure illustrating a carton blank 204 that is similar to the previously described embodiment, with like or similar features having like or similar reference numbers. The blank 204 comprises a top panel 218 foldably connected to first and second side panels 210, 212 at lateral fold lines 222, 224, a bottom panel 208 foldably connected to the second side panel 212 at a lateral fold line 216, and an adhesive flap 219 foldably connected to the bottom panel 208 at a lateral fold line 213 and may serve as a glue flap.

[0042] In the illustrated embodiment, the blank 204 may comprise gusset panels 232, 234 foldably connected to side panels 210, 212 along oblique fold lines 236, 238, and the top panel 218 along fold lines 222, 224, respectively. The first gusset panel 232 comprises portions 232a, 232b foldably connected along fold line 240. The second gusset panel 234 comprises portions 234a, 234b foldably connected along fold line 242. In one embodiment, the gusset panels 232, 234 may comprise apertures (including, cutouts, slots) 220 and 221 configured to align with and at least partially receive a container when the blank 204 is formed into a carton 206. The gusset panels 232, 234 may comprise cutouts 43 adjacent the top panel 218 and a respective side panel 210, 212.

[0043] In one embodiment, the top panel 218 is foldably connected to a first top end flap 50 and a second top end flap 51. The bottom panel 208 is foldably connected to a first bottom end flap 44 and a second bottom end flap 45. The first side panel 210 is foldably connected to a first side end flap 46 and a second side end flap 47. The second side panel 212 is foldably connected to a first side end flap 48 and a second side end flap 49.

[0044] In one embodiment, the end flaps 44, 46, 48, 50 extend along a first marginal area of the blank 204, and are foldably connected at a first longitudinal fold line 56 that extends along the length of the blank. The end flaps 45, 47, 49, 51 extend along a second marginal area of the blank 204, and are foldably connected at a second longitudinal fold line 57 that also extends along the length of the blank. The longitudinal fold lines 56, 57 may be, for example, substantially straight, or oblique at one or more locations to account for blank thickness or for other factors. When the carton 6 is erected, the end flaps 44, 46, 48, 50 close a first end 59 of the carton, and the end flaps 45, 47, 49, 51 close a second end 60 of the carton. In accordance with an alternative embodiment of the disclosure, different flap arrangements can be used for closing the ends 59, 60 of the carton 206.

[0045] As illustrated in Fig. 7, the top panel 218 may include an article display portion 224 (e.g., second portion) foldably connected to a central portion 223 (e.g., first portion) of the top panel 218 along fold line 205. In the illustrated embodiment, the article display portion 224 includes six apertures 110 in a 2x3 arrangement. The apertures 110 are configured to receive the necks of containers C for display when the carton is formed from the blank. The apertures 110 may vary in size to accommodate the varying size of the neck of the containers at the location where a respective container passes through the aperture. The apertures 110 could be alternatively shaped, arranged, and/or configured without departing from the disclosure.

[0046] An exemplary method of erecting the carton 206 is discussed in detail below. At various stages in the erecting, respective portions of the blank 204 are mounted to one another in any suitable manner. For example, at various stages of the erecting process, glue or other adhesive material can be applied at various portions of the blank 204. For example, the adhesive material may be present where appropriate surfaces of the blank are in face-to-face contact. Depending upon the amount and/or type of adhesive material or other fastening mechanisms used, each of the face-to-face contacts described in the Detailed Description section of this disclosure may be more generally referred to as the respective features being in substantially face-to-face contact.

[0047] In one embodiment, the blank 204 is positioned with the exterior surface 2 facing down. The bottom panel 208 and first side panel 210 are folded about fold lines 216, 222 so that the adhesive panel 219 overlaps and is in face-to-face contact with the first side panel 210. Glue can be applied to portions of either the adhesive panel 219 or the first side panel 210 to adhesively secure the adhesive panel 219 and the first side panel 210. The partially erected carton is in the form of a flattened sleeve formation.

[0048] The flattened sleeve formation can be erected into an open-ended sleeve so that products or containers C can be loaded into the erected sleeve. After loading the containers C, the ends 59, 60 of the carton can be closed by first inwardly folding gusset panels 232, 234 along fold lines 240, 242 such that gusset panels 232a, 232b and 234a, 234b are in face-to-face contact and the display portion 224 (e.g., second portion) is lowered relative to the central portion 223 (e.g., first portion) and a respective container extends through the apertures 110 as shown in Figs. 8-10. As shown in Fig. 8, the second portion 224 is positioned at an oblique angle relative to the first portion. Next, each respective end can be closed by at least partially overlapping and adhering the end flaps 44, 46, 48, 50 at one end of the carton and at least partially overlapping and adhering the end flaps 45, 47, 49, 51 at the other end of the carton. The top end flaps at each end (e.g., 50 at end 59, 51 at end 60) are downwardly folded and secured to the bottom end flap (e.g., 44, 45) and side end flaps (47, 49 and 46, 48), respectively. The assembled carton 206 is shown in Fig. 8. The ends 59, 60 of the carton 206 could be closed by other closing steps and features without departing from the disclosure.

Additionally, alternative closing and loading sequences may be used without departing from the disclosure. For example, the containers C can be loaded into the carton 206 after closing the first end 59.

[0049] The blanks according to the present disclosure can be, for example, formed from coated paperboard and similar materials. For example, the interior and/or exterior sides of the blanks can be coated with a clay coating. The clay coating may then be printed over with product, advertising, price coding, and other information or images. The blanks may then be coated with a varnish to protect any information printed on the blanks. The blanks may also be coated with, for example, a moisture barrier layer, on either or both sides of the blanks.

[0050] In accordance with the exemplary embodiments, the blanks may be constructed of paperboard of a caliper such that it is heavier and more rigid than ordinary paper. The blanks can also be constructed of other materials, such as cardboard, hard paper, or any other material having properties suitable for enabling the carton package to function at least generally as described above. The blanks can also be laminated to or coated with one or more sheet-like materials at selected panels or panel sections.

[0051] In accordance with the exemplary embodiments of this disclosure, a fold line can be any substantially linear, although not necessarily straight, form of weakening that facilitates folding therealong. More specifically, but not for the purpose of narrowing the scope of this disclosure, fold lines include: a score line, such as lines formed with a blunt scoring knife, or the like, which creates a crushed portion in the material along the desired line of weakness; a cut that extends partially into a material along the desired line of weakness, and/or a series of cuts that extend partially into and/or completely through the material along the desired line of weakness; and various combinations of these features. In situations where cutting is used to create a fold line, typically the cutting will not be overly extensive in a manner that might cause a reasonable user to incorrectly consider the fold line to be a tear line.

[0052] As an example, a tear line can include: a slit that extends partially into the material along the desired line of weakness, and/or a series of spaced apart slits that extend partially into and/or completely through the material along the desired line of weakness, or various combinations of these features. As a more specific example, one type tear line is in the form of a series of spaced apart slits that extend completely through the material, with adjacent slits being spaced apart slightly so that a nick (e.g., a small somewhat bridging-like piece of the material) is defined between the adjacent slits for typically temporarily connecting the material across the tear line. The nicks are broken during tearing along the tear line. The nicks typically are a relatively small percentage of the tear line, and alternatively the nicks can be omitted from or torn in a tear line such that the tear line is a continuous

cut line. That is, it is within the scope of the present disclosure for each of the tear lines to be replaced with a continuous slit, or the like. For example, a cut line can be a continuous slit or could be wider than a slit without departing from the present disclosure.

[0053] The above embodiments may be described as having one or more panels adhered together by glue. The term “glue” is intended to encompass all manner of adhesives commonly used to secure carton panels or flaps in place.

[0054] The foregoing description illustrates and describes various embodiments of the present disclosure. As various changes could be made in the above construction without departing from the scope of the disclosure, it is intended that all matter contained in the above description or shown in the accompanying drawings shall be interpreted as illustrative and not in a limiting sense. Furthermore, the scope of the present disclosure covers various modifications, combinations, and alterations, etc., of the above-described embodiments. Additionally, the disclosure shows and describes only selected embodiments, but various other combinations, modifications, and environments are contemplated and are within the scope of the inventive concept as expressed herein, commensurate with the above teachings, and/or within the skill or knowledge of the relevant art. Furthermore, certain features and characteristics of each embodiment may be selectively interchanged and applied to other illustrated and non-illustrated embodiments without departing from the scope of the disclosure.

**WHAT IS CLAIMED IS:**

1. A carton for containing a plurality of articles, the carton comprising:  
a plurality of panels that extends at least partially around an interior of the carton, the plurality of panels comprises a top panel, a bottom panel, and at least one side panel foldably connected to the top panel;  
at least one end flap foldably connected to at least one panel of the plurality of panels, the at least one end flap at least partially closes an end of the carton,  
the top panel comprises a first portion foldably connected to a second portion at a fold line, the second portion is positioned at an oblique angle relative to the first portion and configured to receive at least a portion of at least one of the plurality of articles, and at least one of the plurality of articles extends through the second portion.
2. The carton of claim 1, wherein the second portion comprises at least one aperture for receiving at least a portion of at least one of the plurality of articles.
3. The carton of claim 1, wherein the carton further comprises at least one gusset panel foldably connected to the second portion of the top panel and a portion of the at least one side panel.
4. The carton of claim 3, wherein the at least one gusset panel comprises at least one opening aligning with the at least one aperture to at least partially receive a portion of the at least one of the plurality of articles.
5. The carton of claim 1, wherein the fold line is a first fold line and the top panel comprises a third portion foldably connected to the first portion along a second fold line, the third portion is positioned at an oblique angle relative to the first portion and configured to receive at least a portion of at least one of the plurality of articles, and at least one of the plurality of articles extends through the third portion.
6. The carton of claim 1, wherein the top panel is a first top panel, the at least one side panel is a first side panel foldably connected to the top panel, and the carton further comprises a second top panel, and a second side panel foldably connected to the second top panel,  
the first top panel and the second top panel being at least partially overlapped to form a top wall of the carton.
7. The carton of claim 6, further comprising a handle in the top wall, the handle comprises handle panel in the first top panel.

8. The carton of claim 7, wherein the handle panel extends across the first portion of the first top panel.
9. The carton of claim 8, wherein the handle panel is a first handle panel and the handle comprises a second handle panel in the second top panel, the second handle panel being operatively connected to the first handle panel.
10. The carton of claim 9, wherein the handle comprises a third handle panel in the second top panel, the second handle panel and the third handle panel are in face-to-face contact.
11. The carton of claim 9, wherein the at least one end flap comprises a first top end flap foldably connected to the first top panel and a second top end flap foldably connected to the second top panel, the handle the first handle panel comprises a first central portion in the first top panel and the second handle panel comprises a second central portion in the second top panel.
12. The carton of claim 11, wherein the handle comprises a handle end flap in the first top end flap and a handle end portion in the second top end flap, the handle end portion being foldably connected to a central portion of the second handle panel.
13. The carton of claim 12, wherein the handle end portion comprises an opening and the handle end flap comprises article-receiving flaps, the opening in the handle end portion being aligned with the article receiving flaps to create an article-receiving feature of the handle.
14. The carton of claim 6, wherein the first top panel comprises a plurality of openings for receiving a respective article of the plurality of articles.
15. The carton of claim 14, wherein the second top panel comprises at least one opening for being aligned with a respective opening of the plurality of openings in the first top panel.
16. The carton of claim 6, further comprising a first gusset panel foldably connecting the first top panel and the first side panel and a second gusset panel foldably connecting the second top panel and the second side panel.

17. A blank for forming a carton for containing a plurality of articles, the blank comprising:  
a plurality of panels, the plurality of panels comprises a top panel, a bottom panel, and at least one side panel foldably connected to the top panel;  
at least one end flap foldably connected to at least one panel of the plurality of panels, the at least one end flap for at least partially closing an end of the carton when the carton is formed from the blank,  
the top panel comprises a first portion foldably connected to a second portion at a fold line, the second portion is positionable at an oblique angle relative to the first portion and configured to receive at least a portion of at least one of the plurality of articles when the carton is formed from the blank, and at least one of the plurality of articles extends through the second portion when the carton is formed from the blank.
18. The blank of claim 17, wherein the second portion comprises at least one aperture for receiving at least a portion of at least one of the plurality of articles when the carton is formed from the blank.
19. The blank of claim 17, wherein the blank further comprises at least one gusset panel foldably connected to the second portion of the top panel and a portion of the at least one side panel.
20. The blank of claim 19, wherein the at least one gusset panel comprises at least one opening configured to align with the at least one aperture to at least partially receive a portion of the at least one of the plurality of articles when the carton is formed from the blank.
21. The blank of claim 17, wherein the fold line is a first fold line and the top panel comprises a third portion foldably connected to the first portion along a second fold line, the third portion is positionable at an oblique angle relative to the first portion and configured to receive at least a portion of at least one of the plurality of articles when the carton is formed from the blank, and at least one of the plurality of articles extends through the third portion when the carton is formed from the blank.
22. The blank of claim 17, wherein the top panel is a first top panel, the at least one side panel is a first side panel foldably connected to the top panel, and the blank further comprises a second top panel, and a second side panel foldably connected to the second top panel, and  
the first top panel and the second top panel are configured to at least partially overlapped to form a top wall of the carton when the carton is formed from the blank.
23. The blank of claim 22, further comprising handle features in the top wall, the handle features comprises handle panel in the first top panel.

24. The blank of claim 23, wherein the handle features extend across the first portion of the first top panel.
25. The blank of claim 24, wherein the handle panel is a first handle panel and the handle features comprise a second handle panel in the second top panel, the second handle panel being operatively connectable to the first handle panel when the carton is formed from the blank.
26. The blank of claim 25, wherein the handle features comprise a third handle panel in the second top panel, the second handle panel and the third handle panel are in face-to-face contact when the carton is formed from the blank.
27. The blank of claim 25, wherein the at least one end flap comprises a first top end flap foldably connected to the first top panel and a second top end flap foldably connected to the second top panel, the first handle panel comprises a first central portion in the first top panel and the second handle panel comprises a second central portion in the second top panel.
28. The blank of claim 22, wherein the first top panel comprises a plurality of openings for receiving a respective article of the plurality of articles when the carton is formed from the blank, and the second top panel comprises at least one opening for being aligned with a respective opening of the plurality of openings in the first top panel when the carton is formed from the blank.
29. The blank of claim 22, further comprising a first gusset panel foldably connecting the first top panel and the first side panel and a second gusset panel foldably connecting the second top panel and the second side panel.
30. A method of forming a carton for containing a plurality of articles, the method comprising:  
obtaining a blank comprising a plurality of panels, the plurality of panels comprises a top panel, a bottom panel, and at least one side panel foldably connected to the top panel, at least one end flap foldably connected to at least one panel of the plurality of panels, the top panel comprises a first portion foldably connected to a second portion at a fold line;  
forming an interior of the carton at least partially defined by the plurality of panels, the forming the interior of the carton comprising forming an open-ended sleeve;  
positioning the second portion at an oblique angle relative to the first portion; and  
extending at least one of the plurality of articles through the second portion.
31. The method of claim 30, wherein the second portion comprises at least one aperture for receiving at least a portion of at least one of the plurality of articles.

32. The method of claim 30, wherein the blank further comprises at least one gusset panel foldably connected to the second portion of the top panel and a portion of the at least one side panel.
33. The method of claim 32, wherein the at least one gusset panel comprises at least one opening, the forming the open-ended sleeve comprises aligning the at least one opening with the at least one aperture to at least partially receive a portion of the at least one of the plurality of articles.
34. The method of claim 30, wherein the fold line is a first fold line and the top panel comprises a third portion foldably connected to the first portion along a second fold line,  
the method further comprises positioning the third portion at an oblique angle relative to the first portion and extending at least one of the plurality of articles through the third portion.
35. The method of claim 30, wherein the top panel is a first top panel, the at least one side panel is a first side panel foldably connected to the top panel, and the blank further comprises a second top panel, and a second side panel foldably connected to the second top panel, and  
the forming the open-ended sleeve comprises overlapping the first top panel and the second top panel to form a top wall of the carton.
36. The method of claim 35, further comprising forming a handle in the top wall, the handle comprises handle panel in the first top panel.
37. The method of claim 36, wherein the handle panel extends across the first portion of the first top panel.
38. The method of claim 37, wherein the handle panel is a first handle panel and the handle comprises a second handle panel in the second top panel, the forming the handle comprises connecting the second handle panel to the first handle panel.
39. The method of claim 38, wherein the handle comprises a third handle panel in the second top panel, the forming the handle comprises positioning the second handle panel and the third handle panel in face-to-face contact.
40. The method of claim 38, wherein the at least one end flap comprises a first top end flap foldably connected to the first top panel and a second top end flap foldably connected to the second top panel, the first handle panel comprises a first central portion in the first top panel and the second handle panel comprises a second central portion in the second top panel.

41. The method of claim 40, wherein the handle comprises a handle end flap in the first top end flap and a handle end portion in the second top end flap, the handle end portion being foldably connected to a central portion of the second handle panel.

42. The method of claim 41, wherein the handle end portion comprises an opening and the handle end flap comprises article-receiving flaps, the forming the handle comprises aligning the opening in the handle end portion with the article receiving flaps and creating an article-receiving feature of the handle.

43. The method of claim 35, wherein the first top panel comprises a plurality of openings for receiving a respective article of the plurality of articles and the second top panel comprises at least one opening, the method comprises aligning the at least one opening with a respective opening of the plurality of openings in the first top panel.

44. The method of claim 35, wherein the blank comprises a first gusset panel foldably connecting the first top panel and the first side panel and a second gusset panel foldably connecting the second top panel and the second side panel.



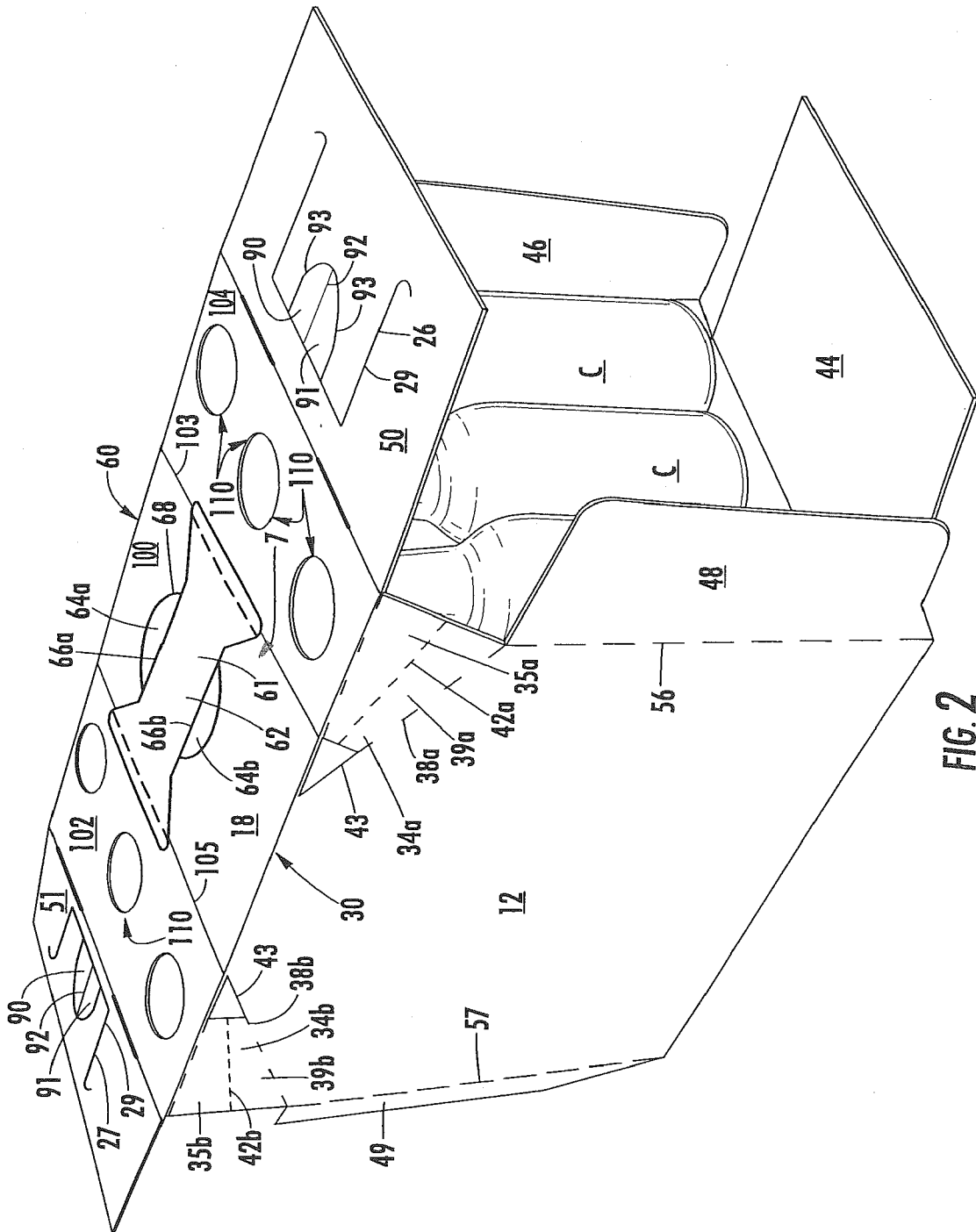

FIG. 2

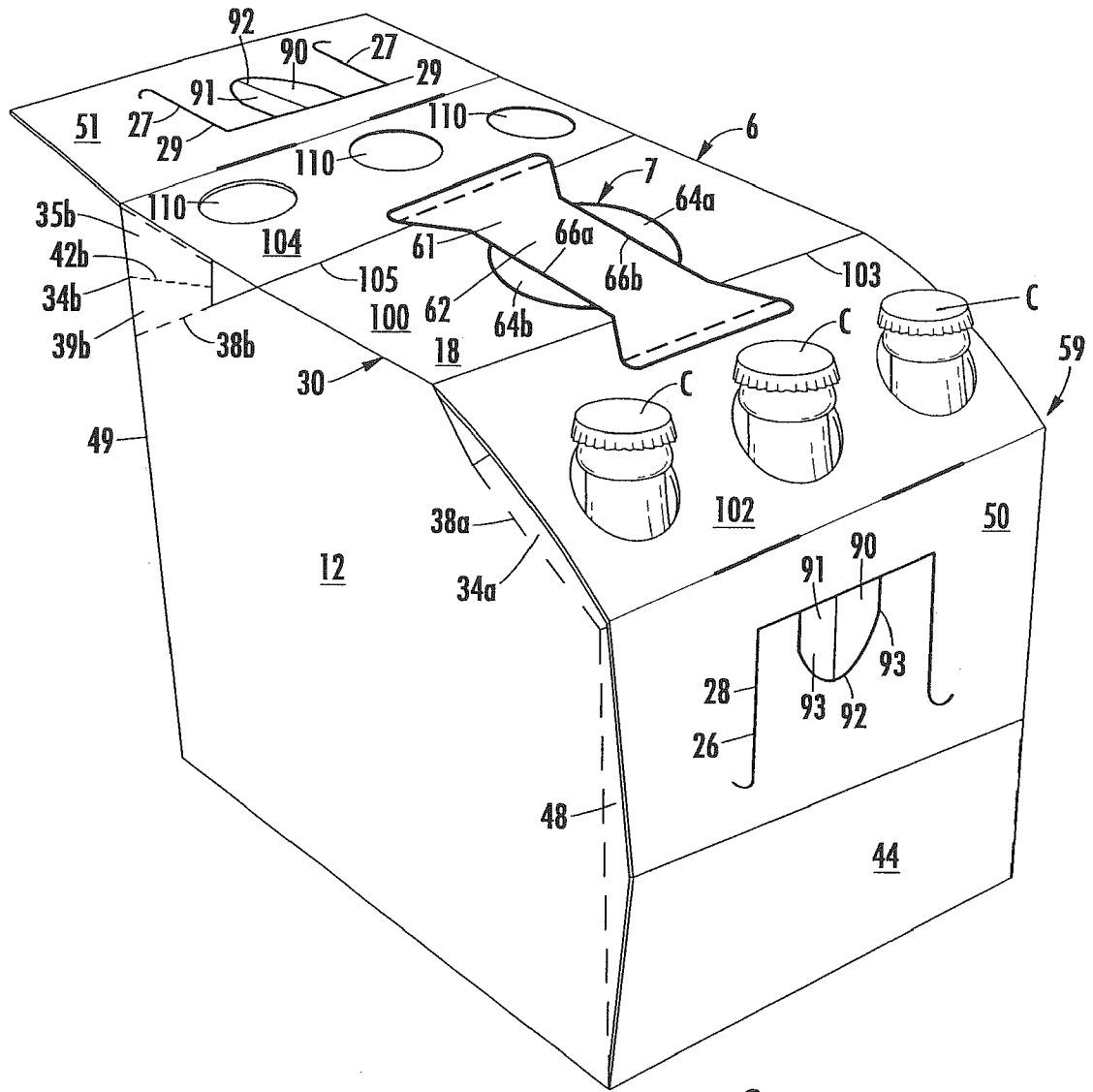

FIG. 3

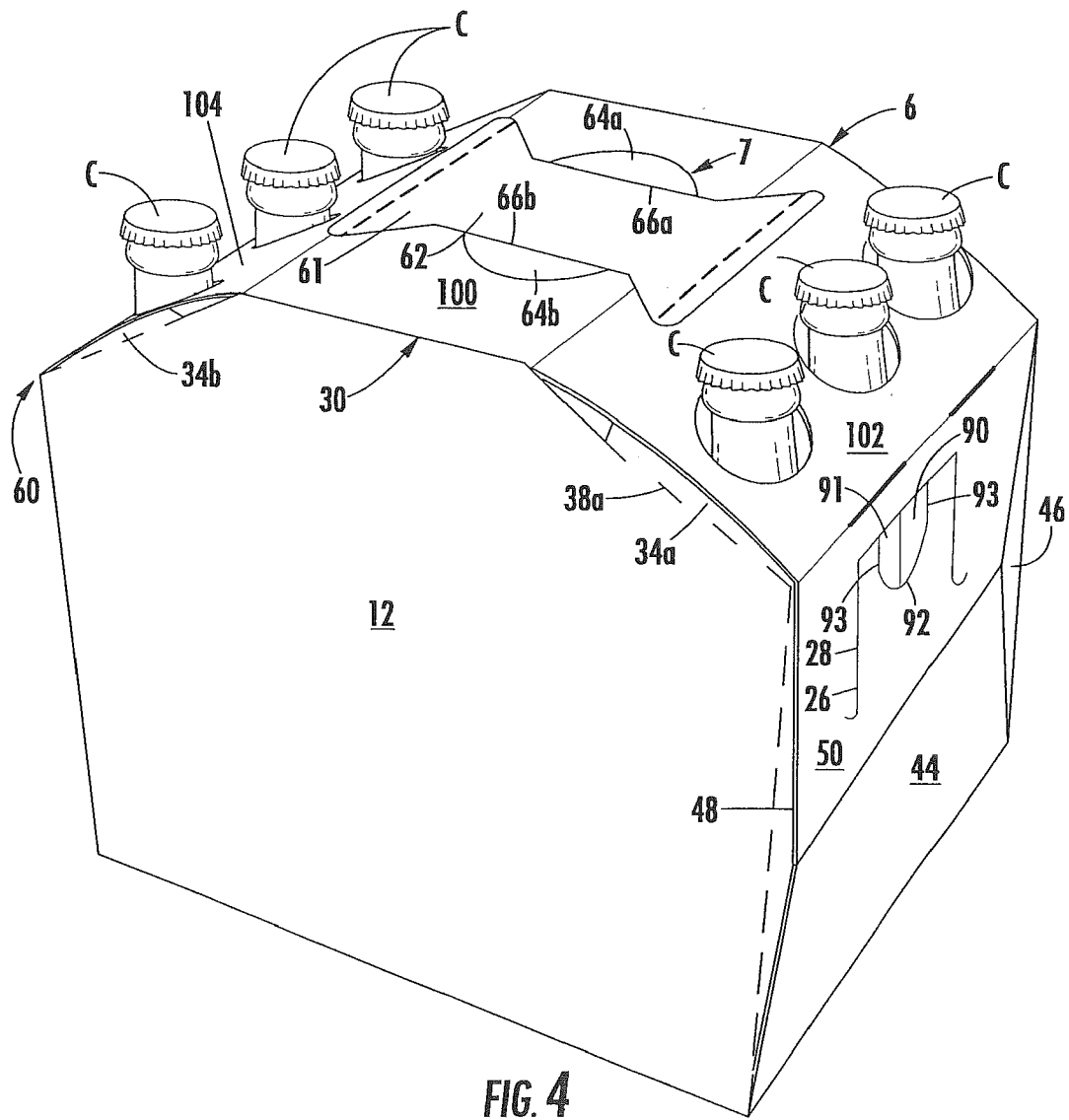
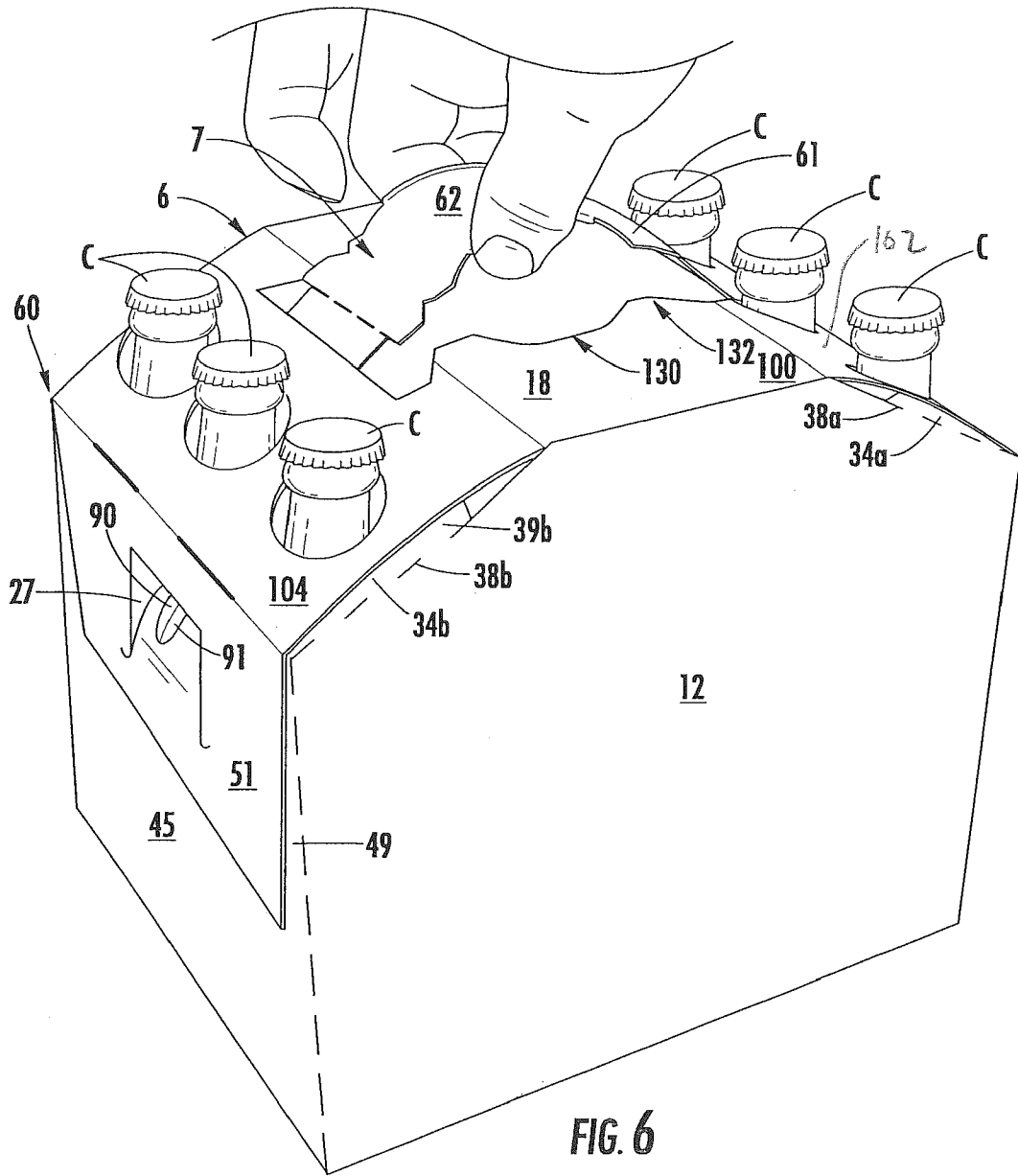

FIG. 4





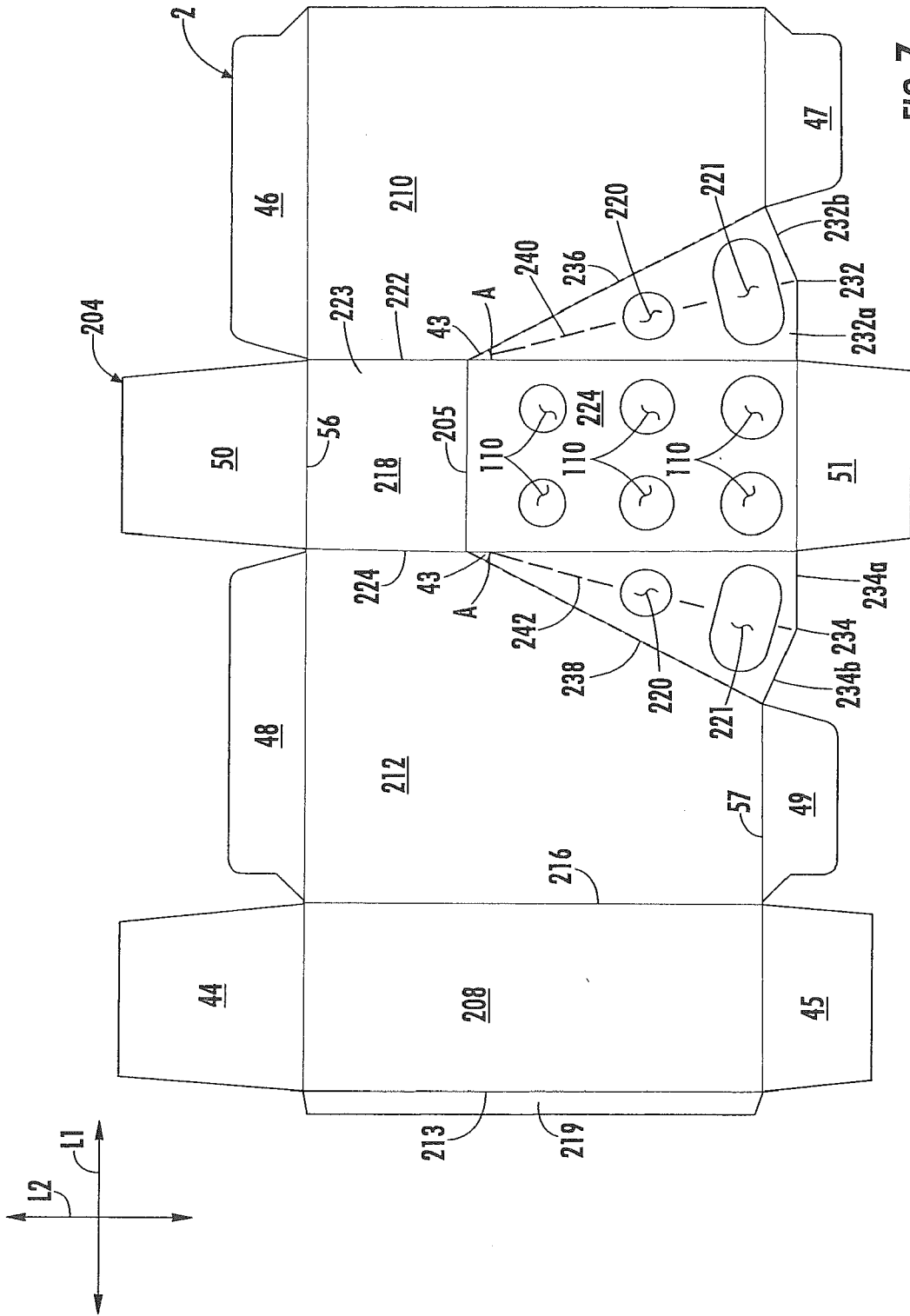

FIG. 7

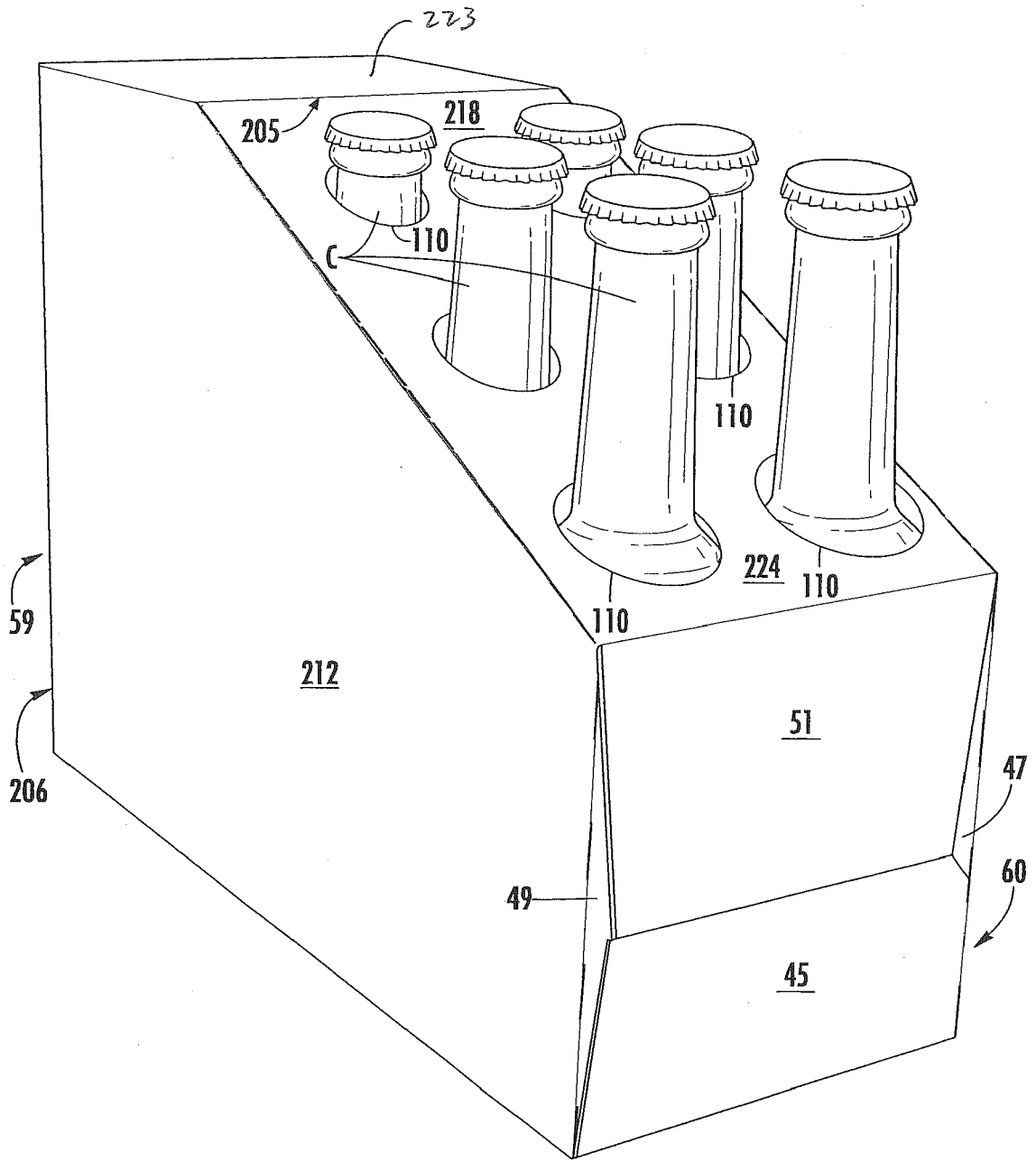

FIG. 8

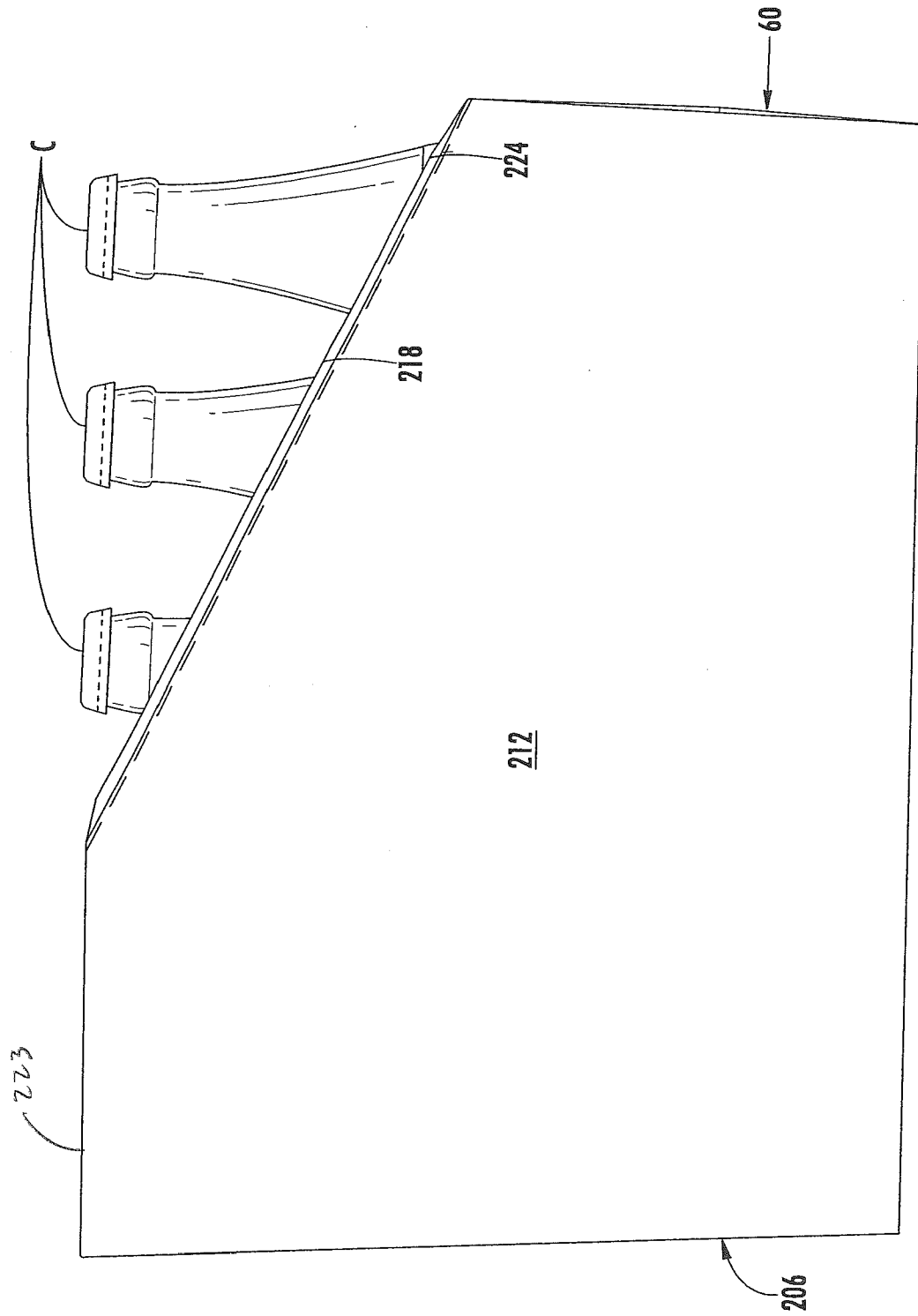
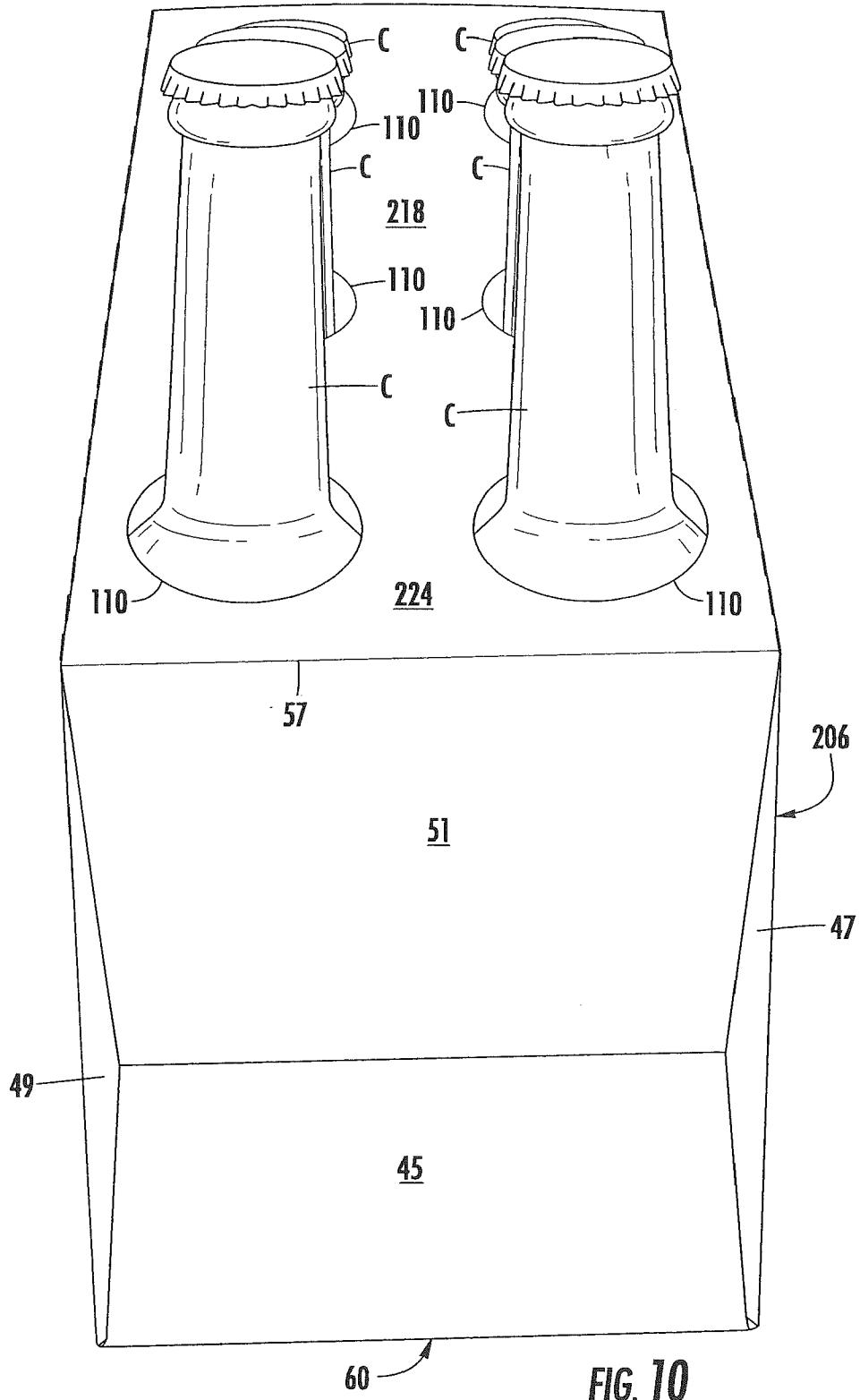

FIG. 9

10/10



**A. CLASSIFICATION OF SUBJECT MATTER****B65D 71/12(2006.01)i, B65D 71/20(2006.01)i, B65D 71/30(2006.01)i, B65D 71/36(2006.01)i**

According to International Patent Classification (IPC) or to both national classification and IPC

**B. FIELDS SEARCHED**

Minimum documentation searched (classification system followed by classification symbols)

B65D 71/12; B65D 5/46; B65D 5/42; B65D 5/36; B65B 5/10; B31B 3/00; B65B 43/10; B65D 71/00; B65D 85/20; B65D 71/20; B65D 71/30; B65D 71/36

Documentation searched other than minimum documentation to the extent that such documents are included in the fields searched

Korean utility models and applications for utility models  
Japanese utility models and applications for utility models

Electronic data base consulted during the international search (name of data base and, where practicable, search terms used)

eKOMPASS(KIPO internal) &amp; Keywords: carton, article, panel, flap, fold, aperture, opening, oblique, receive, and extend

**C. DOCUMENTS CONSIDERED TO BE RELEVANT**

Category*	Citation of document, with indication, where appropriate, of the relevant passages	Relevant to claim No.
X	US 2014-0021080 A1 (FITZWATER et al.) 23 January 2014 See paragraphs [0019]-[0021], [0026]-[0028] and figures 1-2.	1-5, 17-21, 30-34
Y		6-16, 22-29, 35-44
Y	US 2010-0237138 A1 (BRADFORD, PAUL) 23 September 2010 See paragraphs [0020]-[0021], [0024]-[0025] and figure 1.	6-16, 22-29, 35-44
A	US 5549197 A (SUTHERLAND, ROBERT L.) 27 August 1996 See column 2, lines 48-67, column 3, lines 57-67 and figures 1, 7.	1-44
A	US 2011-0226845 A1 (DEPAULA et al.) 22 September 2011 See paragraphs [0023], [0034] and figures 1, 5.	1-44
A	WO 2010-048126 A1(MEADWESTVACO PACKAGING SYSTEMS, LLC. et al.) 29 April 2010 See page 9 and figures 3-4.	1-44

 Further documents are listed in the continuation of Box C. See patent family annex.

\* Special categories of cited documents:

"A" document defining the general state of the art which is not considered to be of particular relevance

"E" earlier application or patent but published on or after the international filing date

"L" document which may throw doubts on priority claim(s) or which is cited to establish the publication date of another citation or other special reason (as specified)

"O" document referring to an oral disclosure, use, exhibition or other means

"P" document published prior to the international filing date but later than the priority date claimed

"T" later document published after the international filing date or priority date and not in conflict with the application but cited to understand the principle or theory underlying the invention

"X" document of particular relevance; the claimed invention cannot be considered novel or cannot be considered to involve an inventive step when the document is taken alone

"Y" document of particular relevance; the claimed invention cannot be considered to involve an inventive step when the document is combined with one or more other such documents, such combination being obvious to a person skilled in the art

"&amp;" document member of the same patent family

Date of the actual completion of the international search

23 June 2015 (23.06.2015)

Date of mailing of the international search report

**23 June 2015 (23.06.2015)**

Name and mailing address of the ISA/KR



 International Application Division  
 Korean Intellectual Property Office  
 189 Cheongsu-ro, Seo-gu, Daejeon Metropolitan City, 302-701,  
 Republic of Korea

Facsimile No. +82-42-472-7140

Authorized officer

HWANG, Chan Yoon

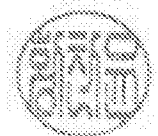
Telephone No. +82-42-481-3347



## INTERNATIONAL SEARCH REPORT

Information on patent family members

International application No.

**PCT/US2015/021423**

Patent document cited in search report	Publication date	Patent family member(s)	Publication date		
US 2014-0021080 A1	23/01/2014	AU 2013-290749 A1	22/01/2015		
		AU 2013-290750 A1	22/01/2015		
		AU 2013-290757 A1	22/01/2015		
		CA 2876182 A1	23/01/2014		
		CA 2876572 A1	23/01/2014		
		CA 2877287 A1	23/01/2014		
		US 2014-021071 A1	23/01/2014		
		US 2014-021081 A1	23/01/2014		
		US 8978889 B2	17/03/2015		
		WO 2014-014505 A1	23/01/2014		
		WO 2014-014506 A1	23/01/2014		
		WO 2014-014513 A1	23/01/2014		
		US 2010-0237138 A1	23/09/2010	CA 2751509 A1	23/09/2010
				CA 2751509 C	29/07/2014
EP 2408686 A2	25/01/2012				
EP 2408686 A4	27/06/2012				
EP 2408686 B1	25/06/2014				
ES 2477222 T3	16/07/2014				
MX 2011009613 A	28/09/2011				
US 8459534 B2	11/06/2013				
WO 2010-107873 A2	23/09/2010				
WO 2010-107873 A3	13/01/2011				
US 5549197 A	27/08/1996			EP 0740629 A1	06/11/1996
		EP 0740629 A4	27/12/2000		
		EP 0740629 B1	05/03/2003		
		JP 03808503 B2	16/08/2006		
		JP 09-509126 A	16/09/1997		
		KR 10-1996-0704774 A	09/10/1996		
		WO 96-17781 A1	13/06/1996		
		US 2011-0226845 A1	22/09/2011	CA 2784750 A1	23/06/2011
CN 102725206 A	10/10/2012				
EP 2512951 A2	24/10/2012				
EP 2512951 A4	01/05/2013				
JP 05535333 B2	02/07/2014				
JP 2013-514946 A	02/05/2013				
MX 2012006833 A	15/08/2012				
US 2013-104500 A1	02/05/2013				
US 8353398 B2	15/01/2013				
WO 2011-075626 A2	23/06/2011				
WO 2011-075626 A3	17/11/2011				
WO 2010-048126 A1	29/04/2010			DE 112009002545 T5	28/03/2013
				WO 2010-048132 A1	29/04/2010