

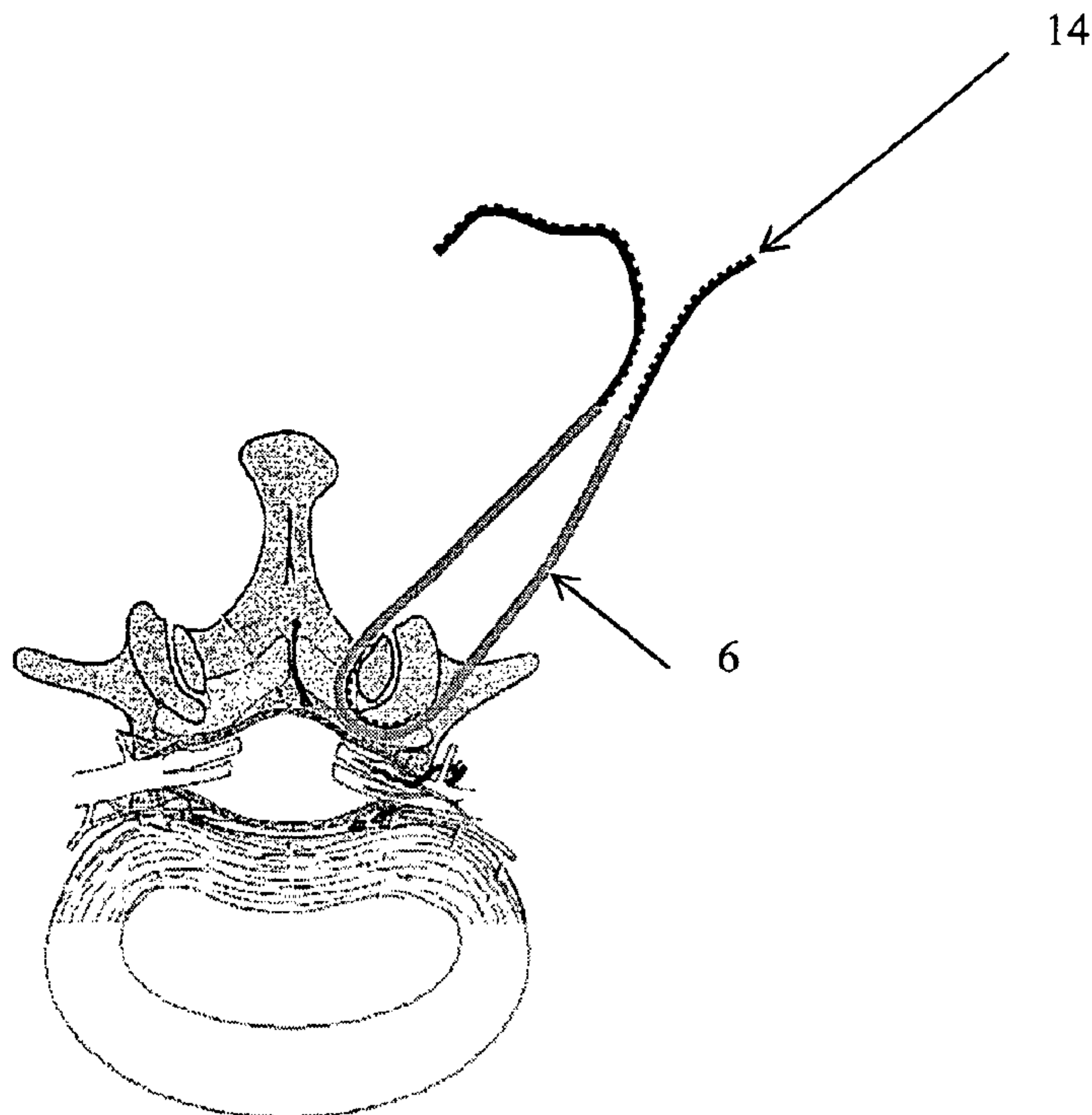

(86) Date de dépôt PCT/PCT Filing Date: 2005/10/15  
 (87) Date publication PCT/PCT Publication Date: 2006/04/27  
 (85) Entrée phase nationale/National Entry: 2007/04/11  
 (86) N° demande PCT/PCT Application No.: US 2005/037136  
 (87) N° publication PCT/PCT Publication No.: 2006/044727  
 (30) Priorités/Priorities: 2004/10/15 (US60/619,306);  
 2004/10/28 (US60/622,865); 2005/05/16 (US60/681,719);  
 2005/05/16 (US60/681,864); 2005/05/27 (US60/685,190)

(51) Cl.Int./Int.Cl. *A61B 17/22* (2006.01),  
*A61D 1/02* (2006.01)  
 (71) Demandeur/Applicant:  
 BAXANO, INC., US  
 (72) Inventeurs/Inventors:  
 BLEICH, JEFFERY L., US;  
 SPISAK, STEVEN A., US;  
 HLAVKA, EDWIN J., US;  
 SAADAT, VAHID, US;  
 MILLER, DAVID R., US;  
 YURCHENCO, JAMES, US  
 (74) Agent: BORDEN LADNER GERVAIS LLP

(54) Titre : DISPOSITIFS ET PROCEDES D'ABLATION DE TISSUS  
 (54) Title: DEVICES AND METHODS FOR TISSUE REMOVAL



(57) **Abrégé/Abstract:**

Methods and apparatus are provided for selective surgical removal of tissue, e.g., for enlargement of diseased spinal structures, such as impinged lateral recesses and pathologically narrowed neural foramen. In one variation, tissue may be ablated, resected, removed, or otherwise remodeled by standard small endoscopic tools delivered into the epidural space through an epidural needle. Once the sharp tip of the needle is in the epidural space, it is converted to a blunt tipped instrument for further safe advancement. A nerve stimulator optionally may be provided to reduce a risk of inadvertent neural abrasion. Additionally, safe epidural placement of the working barrier and epidural tissue modification tools may be further improved with the use of electrical nerve-stimulation-capabilities within the invention that, when combined with neural stimulation monitors, provide neural localization capabilities to the surgeon.

## (12) INTERNATIONAL APPLICATION PUBLISHED UNDER THE PATENT COOPERATION TREATY (PCT)

(19) World Intellectual Property Organization  
International Bureau(43) International Publication Date  
27 April 2006 (27.04.2006)

PCT

(10) International Publication Number  
**WO 2006/044727 A3**

- (51) International Patent Classification:  
A61B 17/22 (2006.01) A61D 1/02 (2006.01)
- (21) International Application Number:  
PCT/US2005/037136
- (22) International Filing Date: 15 October 2005 (15.10.2005)
- (25) Filing Language: English
- (26) Publication Language: English
- (30) Priority Data:  
60/619,306 15 October 2004 (15.10.2004) US  
60/622,865 28 October 2004 (28.10.2004) US  
60/681,719 16 May 2005 (16.05.2005) US  
60/681,864 16 May 2005 (16.05.2005) US  
60/685,190 27 May 2005 (27.05.2005) US
- (63) Related by continuation (CON) or continuation-in-part (CIP) to earlier applications:  
US 60/619,306 (CIP)  
Filed on 15 October 2004 (15.10.2004)  
US 60/622,865 (CIP)  
Filed on 28 October 2004 (28.10.2004)  
US 60/681,719 (CIP)  
Filed on 16 May 2005 (16.05.2005)  
US 60/681,864 (CIP)
- Filed on 16 May 2005 (16.05.2005)  
US 60/685,190 (CIP)  
Filed on 27 May 2005 (27.05.2005)
- (71) Applicant (for all designated States except US): **BAX-ANO, INC.** [US/US]; 764 Talisman Court, Palo Alto, CA 94303 (US).
- (72) Inventors; and  
(75) Inventors/Applicants (for US only): **BLEICH, Jeffery, L.** [US/US]; 764 Talisman Court, Palo Alto, CA 94303 (US). **SPISAK, Steven, A.** [US/US]; 5210 Terner Way #207, San Jose, CA 95136 (US). **HLAVKA, Edwin, J.** [US/US]; 40 Kent Place, Palo Alto, CA 94301 (US). **SAA-DAT, Vahid** [US/US]; 12679 Kane Drive, Saratoga, CA 95070 (US). **MILLER, David, R.** [US/US]; 10050 Firwood Drive, Cupertino, CA 95014 (US). **YURCHENCO, James** [US/US]; 4102 Sutherland Drive, Palo Alto, CA 94303 (US).
- (74) Agent: **BARRISH, Mark, D.**; Townsend and Townsend and Crew, LLP, 379 Lytton Avenue, Palo Alto, CA 94301 (US).
- (81) Designated States (unless otherwise indicated, for every kind of national protection available): AE, AG, AL, AM, AT, AU, AZ, BA, BB, BG, BR, BW, BY, BZ, CA, CH, CN,

[Continued on next page]

(54) Title: DEVICES AND METHODS FOR TISSUE REMOVAL

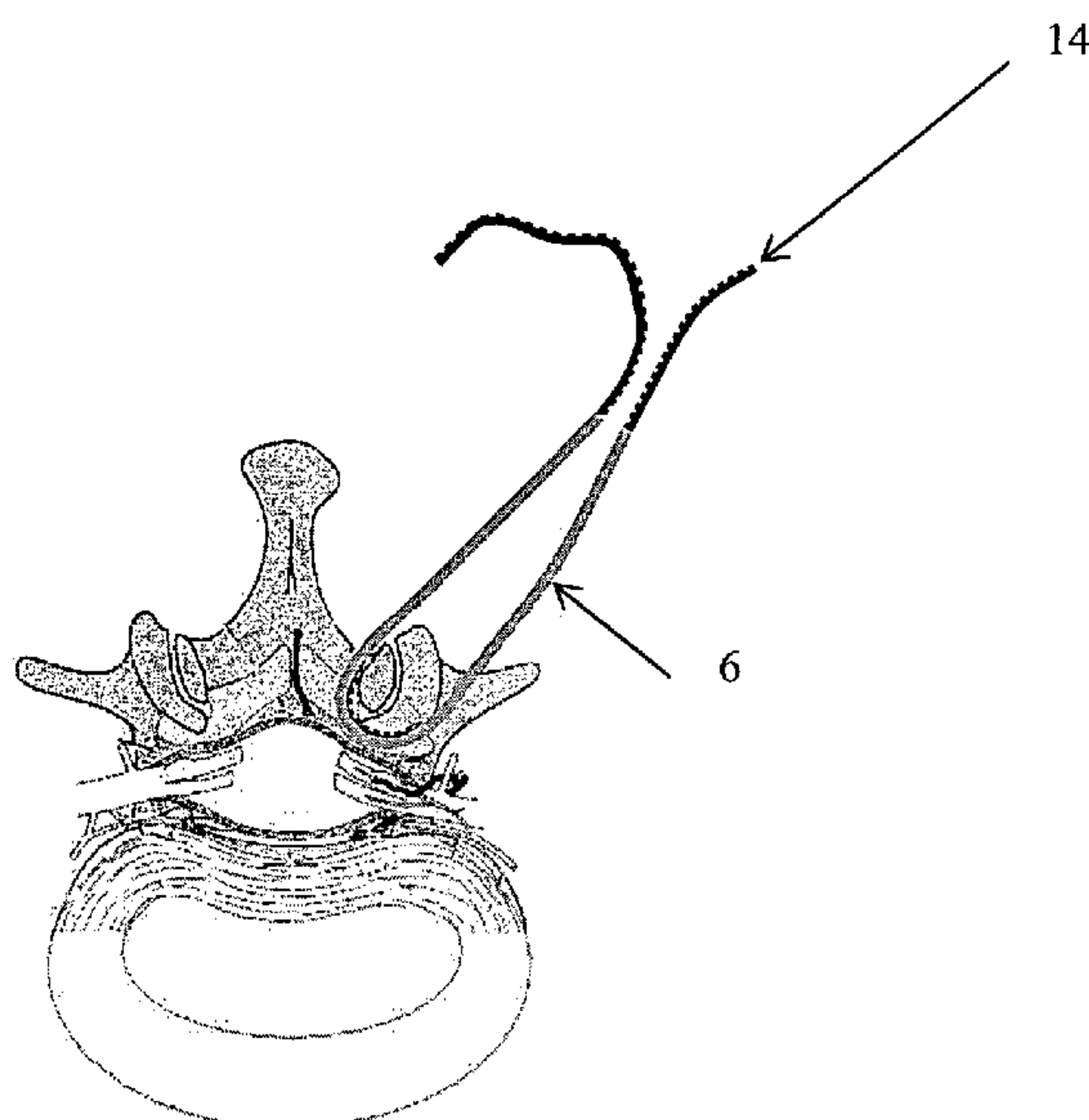

(57) Abstract: Methods and apparatus are provided for selective surgical removal of tissue, e.g., for enlargement of diseased spinal structures, such as impinged lateral recesses and pathologically narrowed neural foramen. In one variation, tissue may be ablated, resected, removed, or otherwise remodeled by standard small endoscopic tools delivered into the epidural space through an epidural needle. Once the sharp tip of the needle is in the epidural space, it is converted to a blunt tipped instrument for further safe advancement. A nerve stimulator optionally may be provided to reduce a risk of inadvertent neural abrasion. Additionally, safe epidural placement of the working barrier and epidural tissue modification tools may be further improved with the use of electrical nerve-stimulation-capabilities within the invention that, when combined with neural stimulation monitors, provide neural localization capabilities to the surgeon.

WO 2006/044727 A3

**WO 2006/044727 A3**

CO, CR, CU, CZ, DE, DK, DM, DZ, EC, EE, EG, ES, FI, GB, GD, GE, GH, GM, HR, HU, ID, IL, IN, IS, JP, KE, KG, KM, KP, KR, KZ, LC, LK, LR, LS, LT, LU, LV, LY, MA, MD, MG, MK, MN, MW, MX, MZ, NA, NG, NI, NO, NZ, OM, PG, PH, PL, PT, RO, RU, SC, SD, SE, SG, SK, SL, SM, SY, TJ, TM, TN, TR, TT, TZ, UA, UG, US (patent), UZ, VC, VN, YU, ZA, ZM, ZW.

**(84) Designated States** (*unless otherwise indicated, for every kind of regional protection available*): ARIPO (BW, GH, GM, KE, LS, MW, MZ, NA, SD, SL, SZ, TZ, UG, ZM, ZW), Eurasian (AM, AZ, BY, KG, KZ, MD, RU, TJ, TM), European (AT, BE, BG, CH, CY, CZ, DE, DK, EE, ES, FI,

FR, GB, GR, HU, IE, IS, IT, LT, LU, LV, MC, NL, PL, PT, RO, SE, SI, SK, TR), OAPI (BF, BJ, CF, CG, CI, CM, GA, GN, GQ, GW, ML, MR, NE, SN, TD, TG).

**Published:**

— *with international search report*

**(88) Date of publication of the international search report:**

2 November 2006

*For two-letter codes and other abbreviations, refer to the "Guidance Notes on Codes and Abbreviations" appearing at the beginning of each regular issue of the PCT Gazette.*



1  
2  
3  
4  
5  
6  
7  
8  
9

TITLE OF THE INVENTION

**DEVICES AND METHODS FOR TISSUE REMOVAL**

Jeffery Lee Bleich

Edwin J. Hlavka

David Miller

Vahid Saadat

Steven Spisak

10

CROSS-REFERENCE TO RELATED APPLICATIONS

11 **[0001]** This application claims the benefit of U.S. Provisional Application No.  
12 60/619,306, filed 15 October 2004, U.S. Application No. 60/622,865, filed 28  
13 October 2004, U.S. Application No. 60/81,719, filed 16 May 2005, U.S. Application  
14 No. 60/681,864, filed 16 May 2004, and U.S. Application No. 60/685,190, filed 27  
15 May 2004, each of which is incorporated by reference herein in its entirety.

16

17

FIELD OF THE INVENTION

18 **[0002]** The present invention relates to methods and apparatus for selective surgical  
19 removal of tissue, such as for the treatment of spinal neural and neurovascular  
20 impingement, through selective resection, ablation, and remodeling of tissue in the  
21 lateral recess, neural foramina and central spinal canal, more particularly, for safely  
22 performing lateral recess and neuroforaminal enlargement of the spine.

23 **[0003]** More particularly, the present invention relates to treating neural and  
24 neurovascular impingement in the spine through the creation of a safe working space  
25 adjacent to neural and neurovascular structures, followed by selective surgical



1 removal of tissue. Both percutaneous and open surgical variations of the invention  
2 are disclosed.

3

4

#### BACKGROUND OF THE INVENTION

5 [0004] Pathological compression of spinal neural and neurovascular structures most  
6 commonly results from a degenerative, age-related process, increasing in prevalence  
7 and severity in elderly populations, with potential congenital anatomic components,  
8 that result in back, radicular extremity pain and both neurological (e.g., sensory) and  
9 mechanical (e.g., motor) dysfunction. Prevalence is also influenced by congenital  
10 spinal anatomy. Disease progression leads to increased neural irritation, neural and  
11 neurovascular impingement, and ischemia, and is frequently accompanied by  
12 progressively increased pain, often in conjunction with reflex, sensory and motor  
13 neurological deficits.

14 [0005] In the United States, Spinal Stenosis occurs with an incidence of between 4  
15 percent and 6 percent of adults 50 years of age or older, and is the most frequent  
16 reason cited for back surgery in patients 60 years of age and older.

17 [0006] Spinal Stenosis often includes neural and/or neurovascular impingement,  
18 which may occur in the central spinal canal, the lateral recesses of the spinal canal, or  
19 in the spinal neural foramina. The most common causes of neural compression within  
20 the spine are spinal disc disease (collapse, bulging, herniation); ligamentum flavum  
21 buckling, thickening and/or hypertrophy; zygapophysial (facet) joint hypertrophy;  
22 osteophyte formation; and spondylolisthesis.

23 [0007] Disease progression increases neural irritation, impingement, and ischemia,  
24 and is frequently accompanied by progressively increased pain, often in conjunction  
25 with reflex, sensory and motor neurological changes (e.g., deficits).

1 [0008] Current surgical treatments for Spinal Stenosis include laminectomy (usually  
2 partial, but sometimes complete), laminotomy and/or facetectomy (usually partial, but  
3 sometimes complete), with or without fusion. While standard surgical procedures  
4 (e.g., spinal decompressions) lead to improvements in symptoms for 6 months or  
5 more in approximately 60% of cases, there is an unacceptable incidence of long-term  
6 complications and morbidity: approximately 40% of patients do not obtain sustained  
7 improvement with current surgical decompressions.

8 [0009] Several companies offer tools that facilitate surgical access to the areas of the  
9 spine where neural impingement is likely to occur, in order to allow the surgeon to  
10 decompress the impinged neural structures through the removal of vertebral lamina,  
11 ligamentum flavum, facet complex, bone spurs, and/or intervertebral disc material.  
12 These surgical resections are frequently (i.e., occurs in 15% to 20% of cases)  
13 accompanied by fusion (arthrodesis). Spinal arthrodesis is performed to fuse adjacent  
14 vertebrae and prevent movement of these structures in relation to each other. The  
15 fusion is commonly a treatment for pain of presumed disc or facet joint origin; for  
16 severe spondylolisthesis; for presumed spinal instability; and for spines that have been  
17 rendered "unstable" by the surgical decompression procedures, as described above.  
18 The definition of "spinal instability" remains controversial in current literature.

19 [0010] Spinal arthrodesis may be achieved through various surgical techniques.  
20 Biocompatible metallic hardware and/or autograft or allograft bone is commonly  
21 placed (e.g., secured) anteriorly and/or posteriorly in the vertebral column in order to  
22 achieve surgical fusion. These materials are secured along and between the vertebral  
23 bodies (to restore vertebral height and replace disk material) and/or within the  
24 posterior elements, typically with pedicle screw fixation. Autograft bone is often  
25 harvested from the patient's iliac crest. Cadaveric allograft is frequently cut in disc



1 shaped sections of long bones for replacement of the intervertebral discs in the fusion  
2 procedure.

3 [0011] Critics have frequently stated that, while discectomy and fusion procedures  
4 frequently improve symptoms of neural impingement in the short term, both are  
5 highly destructive procedures that diminish spinal function, drastically disrupt normal  
6 anatomy, and increase long-term morbidity above levels seen in untreated patients.

7 [0012] The high morbidity associated with discectomy may be due to several factors.  
8 First, discectomy reduces disc height, causing increased pressure on facet joints. This  
9 stress leads to facet arthritis and facet joint hypertrophy, which then causes further  
10 neural compression. The surgically-imposed reduction in disc height also may lead to  
11 neuroforaminal stenosis, as the vertebral pedicles, which form the superior and  
12 inferior borders of the neural foramina, become closer to one another. The loss of  
13 disc height also creates ligament laxity, which may lead to spondylolisthesis, spinal  
14 instability or osteophyte or "bone spur" formation, as it has been hypothesized that  
15 ligaments may calcify in their attempt to become more "bone-like". In addition,  
16 discectomy frequently leads to an incised and further compromised disc annulus.  
17 This frequently leads to recurrent herniation of nuclear material through the surgically  
18 created or expanded annular opening. It may also cause further buckling of the  
19 ligamentum flavum. The high morbidity associated with fusion is related to several  
20 factors. First, extensive hardware implantation may lead to complications due to  
21 breakage, loosening, nerve injury, infection, rejection, or scar tissue formation. In  
22 addition, autograft bone donor sites (typically the patient's iliac crest) are a frequent  
23 source of complaints, such as infection, deformity, and protracted pain. Perhaps the  
24 most important reason for the long-term morbidity caused by spinal fusion is the loss  
25 of mobility in the fused segment of the spine. Not only do immobile vertebral



1 segments lead to functional limitations, but they also cause increased stress on  
2 adjacent vertebral structures, thereby frequently accelerating the degeneration of other  
3 discs, joints, bone and other soft tissue structures within the spine.

4 [0015] Recently, less invasive, percutaneous approaches to spinal discectomy and  
5 fusion have been tried with some success. While these less invasive techniques offer  
6 advantages, such as a quicker recovery and less tissue destruction during the  
7 procedure, the new procedures do not diminish the fact that even less invasive spinal  
8 discectomy or fusion techniques are inherently destructive procedures that accelerate  
9 the onset of acquired spinal stenosis and result in severe long-term consequences.

10 [0016] Additional less invasive treatments of neural impingement within the spine  
11 include percutaneous removal of nuclear disc material and procedures that decrease  
12 the size and volume of the disc through the creation of thermal disc injury. While  
13 these percutaneous procedures may produce less tissue injury, their efficacy remains  
14 unproven.

15 [0017] Even more recently, attempts have been made to replace pathological discs  
16 with prosthetic materials. While prosthetic disc replacement is a restorative  
17 procedure, it is a highly invasive and complex surgery. Any synthetic lumbar disc  
18 will be required to withstand tremendous mechanical stresses and will require several  
19 years of development. Current synthetic disc designs can not achieve the longevity  
20 desired. Further, synthetic discs may not be an appropriate therapeutic approach to a  
21 severely degenerative spine, where profound facet arthropathy and other changes are  
22 likely to increase the complexity of disc replacement. Like most prosthetic joints, it is  
23 likely that synthetic discs will have a limited lifespan and that there will be continued  
24 need for minimally invasive techniques that delay the need for disc replacement.

1 [0018] Even if prosthetic discs become a viable solution, the prosthetic discs will be  
2 very difficult to revise for patients. The prosthesis will, therefore, be best avoided in  
3 many cases. A simpler, less invasive approach to restoration of functional spinal  
4 anatomy would play an important role in the treatment of neural impingement in the  
5 spine. The artificial discs in U.S. clinical trials, as with any first generation  
6 prosthesis, are bound to fail in many cases, and will be very difficult to revise for  
7 patients. The prostheses will, therefore, be best avoided, in many cases. Lumbar  
8 prosthetic discs are available in several countries worldwide.

9 [0019] In view of the aforementioned limitations of prior art techniques for treating  
10 neural and neurovascular impingement in the spine, it would be desirable to provide  
11 methods and apparatus for selective surgical removal of tissue that reduce or  
12 overcome these limitations.

13

14

#### SUMMARY OF THE INVENTION

15 [0020] In view of the foregoing, the present invention provides apparatus and  
16 methods for selective removal of tissue, e.g., soft tissue and bone, preferably in a  
17 minimally invasive fashion. The present invention provides apparatus and methods  
18 for safe and selective delivery of surgical tools into to the epidural space; and for  
19 apparatus and methods that enable safe and selective surgical removal, ablation, and  
20 remodeling of soft tissue and bone, preferably in a minimally invasive fashion, with  
21 the apparatus delivered into the epidural space. An important preferred variation of  
22 the methods and apparatus are used to treat neural and neurovascular impingement in  
23 the spine, through a novel approach to safe and selective enlargement of the  
24 pathologically narrow spinal neural foramen, the impinged lateral recess, and central  
25 canal.



1 [0021] The present invention eliminates much or all of the need to resect non-  
2 impinging tissues in order to gain surgical access. In a preferred embodiment, the  
3 methods and apparatus are used for the treatment of neural and neurovascular  
4 impingement in the spine through a novel approach to safe enlargement of the  
5 pathologically narrow spinal neural foramen and the impinged lateral recess. Tissue  
6 removal may be performed in a partially or completely open surgical fashion, or in a  
7 less invasive or minimally invasive percutaneous fashion. In some embodiments, the  
8 invention provides neural stimulation, localization, and/or protection in order to  
9 provide a protected working space and to facilitate safe tissue remodeling or removal.

10 [0022] The apparatus and methods have been designed to avoid removal of non-  
11 target tissue and to minimize and/or completely prevent trauma to adjacent neural and  
12 vascular structures. The methods and apparatus can be used for the treatment of  
13 neural and neurovascular impingement in the spine, for example, safe enlargement of  
14 the pathologically impinged lateral recess and narrowed spinal neural foramen.  
15 Perineural tissue can be removed safely and selectively in a partially or completely  
16 open surgical fashion, or in a less invasive or minimally invasive percutaneous  
17 fashion. The apparatus and methods described herein can be utilized for lateral recess  
18 and neuroforaminal enlargement to provide adequate bone and soft tissue resection.  
19 The apparatus and methods described herein can reduce unnecessary destruction of  
20 functional bone, ligament or muscle in order to gain access to tissues to be resected.

21 [0023] The present invention encompasses both open and percutaneous approaches to  
22 spinal neurovascular decompression, for example, through passage of an atraumatic,  
23 thin tissue removal device from the epidural space laterally through the neural  
24 foramen. Variations of the present invention preferably provide for access, neural  
25 protection and/or decompression.



1 [0024] Methods and apparatus for spinal lateral recess, neuroforaminal, and/or central  
2 canal enlargement, through selective and safe alteration of the tissues that  
3 pathologically impinge neural and neurovascular structures in the spine are disclosed.  
4 Impinging tissues to be removed from, or remodeled in, the spine's central canal,  
5 lateral recess, and neural foramen, with the herein described methods and apparatus,  
6 can include ligamentum flavum; bone spurs or ligamentous calcifications; localized  
7 disc extrusions; enlarged facet joint complex; bone; scar tissue or adhesions; and  
8 osteophytes.

9 [0025] In an open variation, access may be achieved via an access element  
10 comprising a cannulated probe, which optionally may be similar in shape to currently  
11 used neuroforaminal instruments, such as the Ball-tipped, Woodson Elevator, or  
12 "Hockey Stick" Probes. The probe may be placed through the surgical incision into  
13 the epidural space. A curved atraumatic needle then may be advanced through the  
14 cannula of the probe and driven laterally to cannulate the neural foramen. A  
15 preferably straight, flexible guide wire or needle then may be advanced through the  
16 curved needle and driven posteriorly through the skin of the patient's back.  
17 Alternatively, surgical incisions may be made on either side of the foramen, and the  
18 guide wire may be pulled through the second incision.

19 [0026] Another preferred open surgical approach utilizes a cannulated probe, as  
20 described above, the tip of which is placed into the lateral recess, adjacent to or into  
21 the neural foramina. Next, a curved and atraumatic guide wire is advanced out of the  
22 distal lumen of the cannulated probe, through the neural foramina laterally, and  
23 around the lateral then posterior aspect of the facet capsule, until the distal tip of the  
24 wire is driven back into the surgical opening. At that point, the surgeon has access to  
25 both ends of the guide wire, and the tissue removal device may be pulled or advanced

1 into position via the guide wire. The guide wire may be attached to the tissue removal  
2 device by any of several possible means. One simple method for using a guide wire  
3 to pull a tissue removal device would be to have an eyelet present in the proximal  
4 guide wire, through which the tissue removal device may be thread. Open access  
5 optionally may be aided by the use of image guidance, an epidural endoscope, an  
6 endoscopic channel added to the cannulated probes described above, or any other  
7 visualization technique.

8 [0027] In a percutaneous variation, access may be achieved via an access element  
9 comprising an epidural needle or probe, or via an epidural endoscope having a  
10 working channel. The access element may be positioned in the epidural space, and a  
11 curved atraumatic needle then may be advanced through the needle, probe or working  
12 channel and driven laterally to cannulate the neural foramen. As with the open  
13 variation, a preferably straight, flexible guide wire or needle may be advanced  
14 through the curved needle and driven posteriorly through the skin of the patient's  
15 back. Percutaneous access optionally may be aided by the use of image guidance, an  
16 epidural endoscope or any other visualization technique.

17 [0028] In a preferred embodiment, the methods and apparatus include the placement  
18 of a working backstop or barrier into the epidural space or neural foramina, to a  
19 location between the tool positioned for tissue alteration, and adjacent vulnerable  
20 neural or vascular structures, to help prevent neural or vascular injury during surgery.  
21 In a further preferred embodiment, the methods and apparatus utilize neural  
22 stimulation techniques, to enable neural localization, as a means of improving the  
23 safety of the procedure.



1 [0029] In one variation of the present invention, an epidural needle may be converted  
2 to a working tool in order to resect or remodel spinal tissue, which is enabled by the  
3 use of methods and apparatuses described herein.

4 [0030] After placement of an epidural needle into the epidural space, a special  
5 epidural catheter is threaded through the needle into the epidural space. This catheter  
6 apparatus contains a needle tip cover in its distal end, which, after it is converted to an  
7 open position in the epidural space, is pulled back over the needle tip, by pulling on  
8 the proximal portion of the catheter. The catheter based cover blunts and thereby  
9 protects the vulnerable structures of the spine, such as the dura, from the sharp  
10 epidural needle tip. With the epidural needle tip covered, the needle may be more  
11 safely advanced into the epidural space, in a direction somewhat parallel to the dura,  
12 towards the contralateral or ipsilateral lateral recess and neural foramen. The needle  
13 may be advanced blindly; with image guidance; or with endoscopic guidance.

14 [0031] The epidural catheter, with the cap or cover for the epidural needle, may or  
15 may not contain a rigid or flexible fiberoptic cable. With a fiberoptic element and a  
16 clear tip to the catheter, the epidural needle may be converted to an epidural  
17 endoscope or "needlescope".

18 [0032] One preferred embodiment of the epidural needle apparatus contains two  
19 adjacent lumens ("double barreled"), with a working channel adjacent to the epidural  
20 needle. The working channel may be fixed and permanent, or removable, as in with a  
21 rail and track connection. A removable working channel, in one embodiment, may be  
22 inserted or removed while the tip of the epidural needle remains in the epidural space.  
23 The distal beveled opening of the working channel, in a preferred variation, is located  
24 proximal to and on the same side of the needle as the epidural needle tip beveled



1 opening faces, facilitating visualization of the working channel tools when a  
2 fiberoptic element has been placed in through the epidural needle lumen.

3 **[0033]** The epidural needle or the working channel of the epidural needle may be a  
4 vehicle for insertion of a working backstop or barrier, another apparatus that  
5 facilitates safe tissue resection and remodeling in the epidural space. The barrier is a  
6 thin flat device that may be delivered into or adjacent to the epidural space or neural  
7 foramina, through the needle or working channel, or through an endoscope or open  
8 incision. Such a backstop may consist of a flexible, curved, thin and flat piece of  
9 material. This barrier will serve to protect neural and neurovascular structures from  
10 being damaged during tissue manipulation and resection, because it will be placed  
11 between the tissue to be ablated, resected, irritated, manipulated or remodeled, and the  
12 vulnerable neural and vascular structures or dura. The tools for tissue resection and  
13 ablation will be used on the side of the barrier opposite from the vulnerable neural and  
14 vascular structures, which will be safely protected from inadvertent injury.

15 **[0034]** With access, as well as optional neural protection and/or neural localization,  
16 established, decompression or selective tissue removal or remodeling may proceed. A  
17 tissue removal device with a tissue removal surface is advanced into position, for  
18 example, through, along, over or with the neural protection element, e.g. via rail(s) or  
19 channel(s) of the neural protection element, or along the guide wire(s); or is pulled  
20 into position via the guide wire or the neural protection element, etc. When properly  
21 positioned, the tissue removal surface contacts the impinging tissue slated for  
22 removal.

23 **[0035]** The abrasion device may, for example, include a thin belt or ribbon, with an  
24 abrasive, shaving, and/or cutting surface, that is placed through the neural foramina  
25 and is held firmly against the tissue to be removed. The belt optionally may be

1 placed, at least partially, within a protective sheath or covering, with the area exposed  
2 to the abrasive surface of the device somewhat limited to the area where tissue  
3 abrasion and removal is desired. The abrasive element may be provided in one or  
4 more of a variety of potentially interchangeable shapes, ranging from flat to curved;  
5 narrow to wide; or solid to perforated. The abrasive surface may also have various  
6 enabling designs, or surface patterns, or coarseness of abrasive material. The  
7 apparatus is placed with both free ends of the abrasive element, as well as the ends of  
8 the optional protective sleeve or covering, external to the patient for manipulation by  
9 a medical practitioner.

10 [0036] When the optional protective sleeve or sheath is provided, both ends of the  
11 sleeve may be held under tension, external to the patient, such that the abrasive belt or  
12 ribbon may be pulled back and forth through the sleeve without causing significant  
13 friction against and/or trauma to adjacent tissues. Initially, both ends of the abrasive  
14 ribbon are pulled simultaneously, pulling the device in a posterior and/or lateral  
15 direction, thereby bringing impinging spinal tissue in contact with the abrasive and/or  
16 cutting surface of the ribbon. When one end of the ribbon is pulled with more force  
17 than the other, the ribbon moves in the direction of the stronger pull, while the lesser  
18 pull on the opposite end maintains force and creates friction with movement between  
19 the abrasive surface and the tissue to be resected.

20 [0037] In an open surgical variation, the ribbon or belt and/or the protective covering  
21 or sleeve may be placed through the surgical incision. In a percutaneous variation, the  
22 device may be inserted through a needle over a wire. As with the percutaneous  
23 approaches, placement may be aided by the use of image guidance and/or the use of  
24 an epidural endoscope.



1 [0038] Once the surgical apparatus has been placed, the medical practitioner may  
2 enlarge the lateral recess and neural foramina via frictional abrasion, i.e., by sliding  
3 the abrasive surface across the tissue to be resected. Impinging tissue to be targeted  
4 for abrasion may include, but is not limited to, lateral ligamentum flavum, anterior  
5 and medial facet, and osteophytes. The medical practitioner controls the force and  
6 speed of the abrasive surface against the tissue to be removed, while optional covers  
7 define the tissue exposed to the abrasive element.

8 [0039] One variation of the abrasive element cover envelopes the abrasive surface  
9 and the backside of the belt or ribbon in areas where tissue abrasion is not intended.

10 A nerve stimulator may be incorporated into the abrasive surface and/or the protective  
11 cover or sleeve in order to verify correct placement and enhance safety by allowing  
12 the medical practitioner to ensure that neural tissue is not subject to inadvertent  
13 abrasion.

14 [0040] In one variation, the methods and apparatus include placement of a  
15 compression dressing following the surgical procedure. Following neuroforaminal  
16 and lateral recess enlargement, it may be advantageous to leave, as a surgical  
17 dressing, a belt or ribbon pulled tightly against the abraded tissue surface. It is  
18 expected that a compression dressing will enhance hemostasis, promote healing and  
19 promote subsequent tissue remodeling with the neural foramen more widely open.  
20 Furthermore, the surgical dressing would provide a barrier to trap tissue debris away  
21 from neural or neurovascular structures, while providing an optional technique for  
22 delivering medication, possibly as a depot, to the operative site. Finally, the dressing  
23 would also present a smooth surface towards the nerve root during the immediate  
24 post-operative period.



1 [0041] The present invention also describes methods and apparatus that may be used  
2 as a compression dressing, after tissue resection or ablation. One variation of the  
3 compression dressing is placed in a position where it is firmly wrapped around the  
4 facet and ligamentum flavum through the neural foramina, as illustrated in FIGS. 49.  
5 By tightly pressing against treated tissue surfaces, such a device serves to promote  
6 desired tissue remodeling; to prevent edema from leading to impingement on neural  
7 or vascular tissue during early healing, to contain debris; to promote postoperative  
8 hemostasis; to block scar formation between the raw tissue surfaces and the adjacent  
9 neural and vascular structures; to avoid inflammation or irritation to neural and  
10 vascular structures from contact with adjacent resected tissue surfaces; and as a  
11 mechanism for sustained drug delivery post-operatively (e.g. steroids, procoagulants,  
12 adhesion barriers).

13 [0042] This neuroforaminal compression dressing may, for example, comprise the  
14 optional protective sheath, percutaneously held tightly in place against the abraded  
15 surface. Alternatively or additionally, a separate percutaneously removable  
16 compression dressing may be placed following tissue abrasion, with or without a  
17 biodegradable component. In a further alternative embodiment, an entirely  
18 biodegradable compression dressing may be placed tightly against the abraded  
19 surface, with the compression dressing remaining completely implanted following the  
20 procedure.

21 [0043] In order to reduce a risk of neurological damage during selective tissue  
22 removal, variations of the present invention optionally may provide neural protection  
23 during tissue removal. In one variation, a neural protection element, e.g., a sheath,  
24 shield or backstop, is positioned (e.g., advanced over, or is pulled into place via the  
25 guide wire) such that the neural protection element separates impinging tissue in the

1 neural foramen from the underlying dura, adjacent nerve root, dorsal root ganglion,  
2 and/or neural vasculature. Tissue removal then may proceed by advancing a tissue  
3 removal device into position between impinging tissue and the neural protection  
4 element. The neural protection element preferably comprises an atraumatic profile, to  
5 reduce tissue injury. For example, the element may comprise rounded edges.  
6 Further, low friction materials, coatings, or hydrophilic coatings on the tissue removal  
7 element or on the shield may be helpful in atraumatic introduction of these devices  
8 through the epidural space and neural foramen.

9 [0044] The neural protection element may comprise a window or local opening that  
10 limits exposure of the tissue removal device to the patient's tissue only to the  
11 localized area of the opening. The opening may be positioned such that it directly  
12 underlies the area of desired tissue removal, e.g., such that it directly underlies the  
13 neural foramen and impinging tissue. Irrigation and/or aspiration optionally may be  
14 performed through the window, e.g., for debris removal. Suction also may be drawn  
15 through the window to engage the impinging tissue and/or to provide a seal against  
16 the target tissue. Optionally, the sheath window may comprise a cutting element that  
17 coacts with the tissue removal device. Furthermore, the tissue removal device may  
18 present its cutting elements at the window. The window optionally may be opened,  
19 closed or resized by a medical practitioner as desired. For example, the window may  
20 be closed during delivery, opened during tissue removal, then closed during retrieval  
21 of the sheath. When the neural protection element comprises a backside shield, the  
22 tissue removal device may be delivered through rails within the edges of the shield, or  
23 in conjunction with the shield.

24 [0045] Neural protection can be provided during tissue removal, for example, to  
25 reduce the risk of neurological damage during selective tissue removal. The neural



1 protection element can be positioned after the needle tip has been placed adjacent to,  
2 or within the neural foramina. The neural protection element can be a sheath, shield,  
3 backstop, or combinations thereof.

4 [0046] As an added safety precaution, variations of the present invention optionally  
5 may comprise neural localization elements to ensure proper positioning of the neural  
6 protection element and/or the tissue removal device. The neural localization elements  
7 may comprise separate elements or may be integrated with the neural protection  
8 element and/or the tissue removal device. In one variation, the neural protection  
9 element may comprise a sheath with integrated neural localization elements. In  
10 another variation, the neural protection element may comprise a shield with integrated  
11 neural localization elements. In yet another variation, the neural protection element  
12 may comprise a portion of the tissue removal apparatus that is intended to remain  
13 stationary during tissue removal, located adjacent to the moving tissue removal  
14 elements. The conductive neural localization elements may be used to ensure that the  
15 neural structures and their adjacent vascular structures are on the non-working or  
16 backside of the neural protection element.

17 [0047] Neural localization elements on the backside of the neural protection element  
18 (i.e., the side of the neural protection element that contacts or is in proximity to the  
19 nerve root when properly positioned) may be activated with a stimulation waveform  
20 to stimulate the nerve root, thereby providing a positive control that confirms  
21 placement of the backside in proximity to the nerve root. Appropriate low intensity  
22 electrical stimulation on the backside surface should result in the stimulation of  
23 sensory and/or motor nerves in the patient's extremity. Likewise, neural localization  
24 elements on the working side of the neural protection element, or on the tissue  
25 removal element, (i.e., the side of the neural protection element or tissue removal

1 element that faces impinging tissue slated for removal) may be activated with a  
2 stimulation waveform in anticipation of a negative response or no neural stimulation  
3 that confirms that the working side is not in contact with the nerve root and that tissue  
4 removal may safely proceed. Neural localization elements may be provided on any  
5 side or surface of the neural protection element and/or tissue removal element.

6 [0048] Safe tissue removal, ablation and remodeling with these methods and devices  
7 is further enabled by complementary methods and apparatuses that assist with  
8 accurate neural localization. Neural localization will be performed by neural  
9 stimulation through electrically conductive materials located within the capped  
10 epidural needle tip; within the epidural tools that will be in contact with tissue to be  
11 modified; or one or both sides of the working barrier. Neural stimulation will be  
12 performed in conjunction with monitoring of the patient for sensory and/or motor  
13 response to the electrical impulses.

14 [0049] Said backstop may also contain neural localization capabilities, including a  
15 conductive element on the working side and/or the non-working side. The conductive  
16 element may be used to ensure that the neural and their adjacent vascular structures  
17 are on the non-working side of the barrier. In the instance that the barrier is placed  
18 through the lateral recess or neural foramina, appropriate low intensity electrical  
19 stimulation on the non-working surface should result in the stimulation of sensory or  
20 motor nerves in the patient's extremity, while appropriate electrical conduction on the  
21 working surface should result in no neural stimulation.

22 [0050] Neural stimulation may be monitored by monitoring somatosensory-evoked  
23 potentials (SSEPs), motor-evoked potentials (MEPs), and/or by looking for visual  
24 signs of muscular contraction within the extremities. (Somatosensory evoked  
25 potentials (SSEPs) are non-invasive studies performed by repetitive, sub-maximal,



1 electrical stimulation of a sensory or mixed sensory and motor nerve. In response to  
2 the nerve stimulation the brain generates cerebral action potentials (electrical waves),  
3 that can be measured and recorded over the scalp and spine with surface electrodes.  
4 Typically, needle electrodes are used for intraoperative SSEP monitoring, as they  
5 require less current, and reduce artifact. The recorded response is a series of waves  
6 that reflect activation of neural structures.) SSEP, SEP, MEP or EMG feedback may  
7 be monitored and/or recorded visually, or may be monitored audibly, potentially  
8 conveying quantitative feedback related to the volume or frequency of the auditory  
9 signal (e.g., a Geiger counter type of quantitative auditory feedback). Intensity of  
10 signal or stimulation may be monitored and used to localize the nerve during  
11 placement, as well.

12 [0051] For example, the surgeon may use the neural stimulator to ensure that there is  
13 not stimulation of vulnerable neurons on the working side of the barrier, prior to  
14 initiating tissue manipulation with the working tools. For example, with the barrier in  
15 position in the lateral recess or neural foramina, the surgeon may send electrical  
16 current first along the working side of the barrier, then along the backside of the  
17 barrier. Low level stimulation of the working side would be expected to result in no  
18 neural stimulation, while the same stimulation on the backside of the barrier would be  
19 expected to stimulate dorsal roots, nerve roots, or ganglia.

20 [0052] Neural localization may be further enabled by the addition of surgical  
21 instruments (e.g. cautery devices, graspers, shavers, burrs, probes, etc.). The surgical  
22 instruments can be used that selectively deliver electrical current while the patient is  
23 monitored for nerve stimulation, for example to further enable neural localization, that  
24 selectively deliver electrical current (e.g., stimulate electrically) while the patient is  
25 monitored for nerve stimulation in similar fashions, for example to further neural

1 localization. Quantification of stimulation can enable neural localization. For  
2 example, the user can use a calibrated sensor input that recognizes stronger  
3 stimulation as the device is moved closer to neural structures, or is able to  
4 differentiate between stimulators that are closer to or further from neural structures.  
5 For added safety, a surgical device can be designed to automatically stimulate before  
6 or during tissue removal (e.g., resection), and can be designed to automatically stop  
7 tissue removal (e.g., resection) when nerve stimulation has been sensed.

8 **[0053]** The tissue removal device (e.g., a tissue abrasion device) can be placed, either  
9 percutaneously or through an open surgical approach, through the neural foramina of  
10 the spine, and at least partially around the anterior border of the facet joint, anterior to  
11 the ligamentum flavum. The removal device (e.g., the abrasion device) alternatively  
12 or additionally can be placed through the neural foramen anterior to the facet joint,  
13 but into and through the body of, or posterior to the ligamentum flavum. After spinal  
14 neuroforaminal placement, the device can be used to remove or selectively remove  
15 tissues that impinge on the neurovascular structures within the lateral recess and  
16 neural foramen, anterior to the facet joint, thereby enlarging the lateral recess and  
17 neural foramina via selective tissue removal. Impinging tissue to be targeted for  
18 removal can include, but is not limited to, lateral ligamentum flavum, anterior and  
19 medial facet capsule, facet bone, and/or osteophytes. In another variation the tissue  
20 removal device can be positioned for removal of central stenosis.

21 **[0054]** The tissue removal surface of the tissue removal device may comprise various  
22 tissue removal elements for selectively removing all or a portion of the impinging  
23 tissue. In one variation, the tissue removal surface comprises one or more non-  
24 powered mechanical tissue removal elements that are drawn or pulled, e.g., under  
25 tension, across the impinging tissue to remove the tissue by cutting, shaving, etc.



1 [0055] During tissue removal, the tissue removal device may be drawn across  
2 impinging tissue in a single direction or may be reciprocated. The mechanical  
3 elements may comprise cutting elements, such as blades, band saws, or wire saws.  
4 The blades may comprise various shapes (e.g. serrated), sizes, and configurations, as  
5 desired. Alternatively, the mechanical elements may comprise abrasives, such as a  
6 diamond or oxide coating. Furthermore, coating blades may be provided to achieve  
7 a guillotine-type or scissor-type cutting action. Blades may be attached to the tissue  
8 removal device or may be formed by punching, grinding, or stamping through the  
9 device with optional subsequent grinding of the punched edge. Alternatively, the  
10 blades may be formed by a chemical etching process. The blades may comprise a 3-  
11 dimensional profile to facilitate cutting, for example, a bow or a corrugation or a  
12 'cheese grater' profile. Furthermore, the blades may be placed at one or more angles  
13 relative to the direction of tissue removal. Cutting surfaces of the blades may be  
14 oriented in a single direction or may be oriented in multiple directions. Additionally,  
15 the blades may be serrated. As another alternative, the mechanical elements may  
16 comprise cutting wires or wire saws, for example, one or more Gigli saws. A  
17 plurality of cutting wires or Gigli saws may be joined or woven together or flattened  
18 to form a substantially planar cutting surface. Further, a wire saw(s) or Gigli saw(s)  
19 may be attached to a ribbon backing, said ribbon thereby limiting the depth of  
20 penetration of the tissue removal device ("depth-stop ribbon").

21 [0056] In another variation, the tissue removal surface comprises one or more  
22 powered mechanical tissue removal elements. The powered mechanical tissue  
23 removal elements may comprise, for example, band saws, belt shavers, rotary burrs or  
24 blades, reciprocating burrs or blades, etc.

1 [0057] The tissue removal surface can have an energy delivery system that ablates,  
2 vaporizes, breaks up, or changes the modulus of the tissue, for example, aiding tissue  
3 removal. The tissue removal system can deliver one or more of various energies to  
4 facilitate removal of tissue. The energies can be electrical, ultrasound, thermal,  
5 microwave, laser, cryo, or combinations thereof. In another variation, the tissue  
6 removal surface comprises one or more electrosurgery elements for tissue  
7 removal/ablation. The electrosurgery elements additionally or alternatively can be  
8 utilized to achieve hemostasis and/or to facilitate neural localization. Monopolar or  
9 bipolar RF elements can, for example, be utilized and activated with a thermal or  
10 substantially non-thermal waveform.

11 [0058]

12 [0059] Any other known tissue removal elements may be utilized with the tissue  
13 removal device including, for example, lasers, high-pressure fluid, thermal elements,  
14 radioactive elements, etc. It should be understood that various tissue removal  
15 elements may be used in any combination, as desired.

16 [0060] In order to reduce friction during placement, diagnosis, treatment and/or  
17 removal, the access elements, the neural protection element and/or the tissue removal  
18 device can have or comprise a lubricious coating, for example, a hydrophilic coating,  
19 a poly(tetrafluoroethylene) coating, etc. The coating can reduce friction during  
20 placement, diagnosis, treatment and/or removal. Furthermore, the tissue removal  
21 device, the access elements and/or the neural protection element may be  
22 biocompatible and/or non-friable. Debris removal elements also may be provided.

23 [0061] The method can be performed through an epidural needle that has been  
24 inserted into the epidural space. The epidural needle may be inserted percutaneously,  
25 or via an open incision, via a standard posterior paramedian (interlaminar) or midline



1 (interspinous) approach, for example, using a loss of resistance technique known to  
2 those having an ordinary level of skill in the art.

3 **[0062]** A catheter can then be threaded through the needle and into the epidural space.

4 The catheter distal tip can have a protective hood, cover, or needle cap, for example,

5 which can be designed to be placed over the needle tip. When the catheter distal tip

6 has been placed in the epidural space, the user can open the protective hood covering.

7 After the protective covering is opened, the catheter can be slidably retracted through

8 the needle until the protective hood cover firmly encloses the sharp edges or points in

9 the area of the epidural needle tip. When the protective hood cover firmly protects the

10 needle tip, the catheter can be fixed to the needle. The needle with the protective

11 hood covering on the needle tip can be configured as a blunt instrument.

12 **[0063]** The needle can then be advanced until the needle distal end is in a lateral

13 recess, adjacent to the neural foramina. The user can use tactile feedback from the

14 needle, image guidance (e.g., fluoroscopy), or combinations thereof, to position the

15 needle distal end to the lateral recess.

16 **[0064]** A tissue removal device can be positioned between the impinging tissue to be

17 removed and the neural protection element. A curved flexible stylet can be inserted

18 into the catheter. The catheter can then be advanced through the needle. The tip of

19 the catheter can be driven, for example, along the inferior border of the facet,

20 cephalad to the neural and neurovascular structures, and through the neural foramina

21 laterally.

22 **[0065]** An atraumatic curved needle can be advanced through the epidural catheter

23 and driven through the neural foramina, also between the tissue to be removed and the

24 neural structures to be protected.

1 [0066] A curved thin shield can be advanced through the epidural needle and driven  
2 through the neural foramina, also positioned between the tissues to be removed and  
3 tissues to be protected.

4 [0067] The catheter, curved needle, or shield can serve as a barrier, for example,  
5 between the tissue to be removed and the neural and neurovascular structures. The  
6 catheter, curved needle, or shield can serve can assist in the delivery of a barrier, for  
7 example, between the tissue to be removed and the neural and neurovascular  
8 structures. The catheter, curved needle, or shield can be expanded within the neural  
9 foramina to serve as a barrier, for example, between the tissue to be removed and the  
10 neural and neurovascular structures. The neural protection element can have an  
11 atraumatic profile, for example, to reduce tissue injury. The neural protection element  
12 can have rounded edges.

13 [0068] The user can visualize the epidural space, for example, via a fiber optic  
14 element that can be covered by a distal clear tip. The fiber optic element can be  
15 delivered within the epidural catheter. The fiber optic element can be delivered via a  
16 working channel within or adjacent to the epidural needle.

17 [0069] In an open surgery variation, access can be achieved via an access element  
18 comprising a cannulated probe, such as a cannulated ball-tipped probe, Woodson  
19 elevator, or Hockey Stick hybrid. The probe can be placed through the surgical  
20 incision into the epidural space. A curved element, such as an atraumatic needle, then  
21 can be advanced through the cannula of the probe and driven laterally to cannulate the  
22 neural foramen. In addition to direct visualization and tactile feedback, open access  
23 can be aided by the use of image guidance, an epidural endoscope or any other  
24 visualization technique.



1 [0070] When the neural protection element comprises a sheath, the tissue removal  
2 device can be delivered through or along the sheath, or in conjunction with the sheath.  
3 The sheath can have a window or local opening that limits exposure of the tissue  
4 removal device to the patient's tissue only to the localized area of the opening. The  
5 opening can be positioned directly underlying the area of desired tissue removal, e.g.,  
6 directly underlying the neural foramen and impinging tissue in the central canal, the  
7 lateral recess, and/or within the neural foramen.

8 [0071] Irrigation and/or aspiration can be performed through the window, e.g., for  
9 debris removal. Suction also can be drawn through the window to engage the  
10 impinging tissue and/or to provide a seal against the target tissue and/or to remove  
11 tissue debris and/or to remove fluid. The sheath window can have a cutting or  
12 ablation element that coacts with the tissue removal device. The tissue removal  
13 device can present the tissue removal elements at the window. The window  
14 optionally can be opened, closed or resized by a medical practitioner as desired. For  
15 example, the window can be closed during delivery, opened during tissue removal,  
16 then closed during retrieval of the sheath.

17 [0072] Neural localization elements can be used to improve positioning of the neural  
18 protection element and/or the tissue removal device. The neural localization elements  
19 can have separate elements or can be integrated with the neural protection element  
20 and/or the tissue removal device. In one variation, the neural protection element can  
21 have a sheath or other element with integrated neural localization elements.

22 Electrically conductive neural localization elements can be used to ensure that the  
23 neural structures are on the non-working or backside of the barrier. Neural  
24 localization elements on the back side of the neural protection element (i.e., the side  
25 of the neural protection element that contacts the nerve root when properly

1 positioned) can be activated with a back side electrical current (e.g., delivered as a  
2 waveform). The back side electrical current can stimulate the nerve root or other  
3 neural structures, for example, providing a signal to the user that the back side has  
4 been placed adjacent to the nerve root. Low intensity electrical current on the back  
5 side surface can result in the stimulation of sensory or motor nerves in the patient's  
6 extremity. Neural localization elements on the working side of the neural protection  
7 element (i.e., the side of the neural protection element that faces impinging tissue  
8 slated for removal) can be activated with a front side electrical current (e.g., delivered  
9 as a waveform, for example with distinct characteristics than the waveform of the  
10 back side electrical current). The electrical current can stimulate a negative response  
11 or no neural stimulation, for example, providing a signal to the user that the working  
12 side is not in contact with the nerve root and that tissue removal may safely proceed.  
13 Neural localization elements can be provided on any or all sides of the neural  
14 protection element.

15 [0073] After access is established, optionally including neural protection and/or  
16 neural localization, and the tissue removal device can be positioned such that the  
17 tissue removal surface contacts the impinging tissue slated for removal, then the user  
18 can selectively remove tissue. Tissue removal can result in neural and/or  
19 neurovascular decompression.

20 The elastic modulus of impinging tissue can be altered, for example, to facilitate  
21 removal of the tissue. For example, the modulus of soft tissue can be increased to  
22 gain purchase on the soft tissue with the tissue removal elements. Such modulus  
23 alteration can be achieved, for example, through compression, denaturation,  
24 electrosurgical exposure, thermal remodeling (hot or cold), chemical alteration, epoxy  
25 or glues or hydrogels, or any combination thereof. Remodeling of the tissue during or



1 after modulus alteration can alleviate impingement and obviate or reduce a need for  
2 tissue removal.

3 **[0074]** In combination with the energy delivery system, or as a stand alone tissue  
4 removal option, one or more non-powered mechanical tissue removal elements (e.g.  
5 abrasives or cutting elements such as blades or saws) can be drawn across the  
6 impinging tissue to remove the tissue by cutting, shaving, slicing, scissoring,  
7 guillotining, scraping, tearing, abrading, or combinations thereof. The blade can be  
8 drawn across impinging tissue in a single direction and/or can be reciprocated. The  
9 mechanical tissue removal elements can have abrasives, such as a diamond or oxide  
10 coating.

11 **[0075]** The blades can have various shapes, sizes and configurations. The blades can  
12 coact, for example, in a guillotine-type or scissor-type cutting action. The blades can  
13 be attached to or integral with the tissue removal device. The blades can be formed  
14 by grinding, punching or stamping through the tissue removal device. The blades can  
15 be formed by grinding of a punched or stamped edge of the tissue removal device.  
16 The blades can be formed by a chemical etching process. The blades can have a 3-  
17 dimensional profile to facilitate cutting, for example, a bow or a corrugation or a  
18 'cheese grater' profile. The blades can be placed at one or more angles relative to the  
19 direction of tissue removal. The blades can be configured with the blade cutting  
20 across the tissue (i.e., similar to a band saw). The blades can have cutting surfaces.  
21 The cutting surfaces can be oriented in a single or multiple directions. The blades can  
22 be serrated.

23 **[0076]** The saw can be a wire saw or saws. The wire saw can be a Gigli saw.  
24 Multiple wire saws or Gigli saws can be joined or woven together or flattened to form

1 a substantially planar cutting surface. The wire saw can be mounted on a flat ribbon.

2 The ribbon can be a depth stop, for example, limiting for saw penetration.

3 [0077] The tissue removal surface can have one or more powered mechanical tissue  
4 removal elements. The powered mechanical tissue removal elements can have, for  
5 example, band saws, belt shavers, rotary burrs or blades, reciprocating burrs or blades,  
6 or combinations thereof.

7 [0078] The apparatus and methods can facilitate selective elimination of pathological  
8 spinal tissue, thereby enabling symptomatic relief in patients suffering from spinal  
9 stenosis.

10 [0079] A method for modifying spinal anatomy is disclosed. The method includes  
11 delivering a surgical apparatus to an epidural space and surgically altering tissues that  
12 impinge neural or vascular structures in the lateral recess, neural foramina or central  
13 canal of the spine with the apparatus. Surgically altering tissues can include ablating  
14 tissue, resecting tissue, removing tissue, abrading tissue, retracting tissue, stenting  
15 tissue, retaining tissue, or thermally shrinking tissue. Surgically altering tissues can  
16 additionally include enlarging the lateral recess, neural foramina or central canal of  
17 the spine.

18 [0080] Delivering the surgical apparatus to an epidural space can include delivering  
19 an epidural needle to the epidural space, and enlarging the lateral recess, neural  
20 foramina or central canal of the spine can include focally altering tissue with tools  
21 delivered through the epidural needle. Delivering the surgical apparatus to an  
22 epidural space also can include delivering an epidural needle to the epidural space,  
23 and enlarging the lateral recess, neural foramina or central canal of the spine also can  
24 include focally altering tissue with tools delivered through a working channel  
25 disposed adjacent to the epidural needle.



1 [0081] Delivering the surgical apparatus can include converting the epidural needle to  
2 an endoscope within the epidural space. Delivering the surgical apparatus to an  
3 epidural space also can include delivering a working endoscope to the epidural space,  
4 and enlarging the lateral recess, neural foramina or central canal of the spine can also  
5 include focally altering tissue with tools delivered through the working endoscope.  
6 Delivering the surgical apparatus can also include converting the epidural needle into  
7 a blunt tipped instrument after placement of the needle's tip within the epidural space.  
8 Converting the epidural needle can also include threading an epidural catheter through  
9 the epidural needle into the epidural space, and covering the needle's tip with an  
10 epidural needle cover delivered via the catheter.

11 [0082] Delivering the surgical apparatus can also include converting the epidural  
12 needle into an endoscope via a visualization element disposed within the epidural  
13 catheter. Delivering the surgical apparatus can include infusing fluid into the epidural  
14 space to improve visualization. Delivering the surgical apparatus can include  
15 inserting a removable working channel alongside the surgical apparatus. Delivering  
16 the surgical apparatus can include inserting a distal tip of a dual lumened epidural  
17 needle into the epidural space and using at least one of the dual lumens as a working  
18 channel for the delivery of instruments into the epidural space. Delivering the  
19 surgical apparatus can include inserting an instrument chosen from the group  
20 consisting of a tissue cauterization tool, a tissue laser device, a radiofrequency  
21 delivery device, a ronguer, a tissue grasper, a tissue rasp, a probe, a bone drill, a tissue  
22 shaver, a burr, a tissue sander and combinations thereof through the surgical  
23 apparatus.

24 [0083] Delivering the epidural needle can include inserting the epidural needle to a  
25 position with a tip of the needle in proximity to where treatment will be directed.

1 Delivering the epidural needle can include inserting the epidural needle at an  
2 interspace below the level of the spine where the treatment will be directed.

3 [0084] Delivering surgical apparatus can include delivering the apparatus via an open  
4 surgical route. Delivering the epidural needle can include delivering the needle via a  
5 posterior, interlaminar percutaneous route. Delivering the epidural needle can include  
6 delivering the needle via a posterior, translaminar, percutaneous route. Delivering the  
7 epidural needle can include delivering the needle via a posterior, midline,  
8 interspinous , percutaneous route. Delivering the epidural needle can include  
9 delivering the needle via a percutaneous route through the neural foramen from its  
10 lateral aspect. Enlarging can include placing a mechanical barrier or backstop  
11 between tissue to be resected and adjacent neural or vascular structures. The barrier  
12 can be steerable.

13 [0085] The method of modifying the spinal anatomy can include confirming proper  
14 placement of the surgical apparatus. Confirming proper placement can include  
15 confirming proper placement with a nerve stimulator. Confirming proper placement  
16 with a nerve stimulator further comprises confirming proper placement with  
17 stimulation leads placed on a tissue remodeling side of the surgical apparatus. The  
18 method of modifying the spinal anatomy can include confirming proper placement of  
19 the surgical apparatus or barrier with a nerve stimulator having stimulation leads  
20 placed on a tissue remodeling side of the barrier or on a back side of the barrier.

21 [0086] The method of modifying the spinal anatomy can include monitoring nerve  
22 stimulation with the nerve stimulator via somatosensory evoked potentials (SSEPs).  
23 The method of modifying the spinal anatomy can include monitoring nerve  
24 stimulation with the nerve stimulator via motor evoked potentials (MEPs). The  
25 method of modifying the spinal anatomy can include monitoring nerve stimulation



1 with the nerve stimulator via motor evoked patient movement. The method of  
2 modifying the spinal anatomy can include monitoring nerve stimulation via verbal  
3 patient sensory response to the nerve stimulator.

4 [0087] The method of modifying the spinal anatomy can include monitoring  
5 enlargement via imaging. The method of modifying the spinal anatomy can include  
6 surgically altering the tissues under fluoroscopic imaging, MRI imaging, CT  
7 imaging., ultrasound imaging., radiological imaging, surgical triangulation, infrared or  
8 RF surgical triangulation.

9 [0088] The method of modifying the spinal anatomy can include placing an element  
10 that provides tissue compression of surgically remodeled tissue or bone surface in  
11 order to enlarge the neural pathway or foramina post-surgical enlargement. The  
12 method of modifying the spinal anatomy can include placing an element that provides  
13 tissue compression and retention in order to remodel tissue or bone surface in order to  
14 enlarge the neural pathway or foramina de novo. Placing the element can include  
15 placing the element using a percutaneous technique via the epidural space, through a  
16 neural foramen at a level to be treated for spinal stenosis, and around a facet complex  
17 or a lamina adjacent to the facet complex. The method of modifying the spinal  
18 anatomy can include tightening the element to a determined tension. Placing the  
19 element can include placing an element having a posterior anchor that is a cord or tie  
20 looped through a hole that has been drilled in the cephalad lamina of the immediately  
21 adjacent vertebrae. The method of modifying the spinal anatomy can include  
22 tensioning the element to a determined level via a tension gauge or other  
23 measurement device element holding tension against the tissue to be remodeled.

1 [0089] The method of modifying the spinal anatomy can include releasing a  
2 biologically active material for the purposes of decreasing inflammation, or  
3 promoting remodeling of soft tissue or bone growth from the element.

4 [0090] Apparatus for focal tissue alteration are disclosed herein. The apparatus have  
5 an element configured for placement into an epidural space, and surgical tools  
6 configured for delivery through the element into the epidural space to remodel spinal  
7 anatomy that impinges upon neural, neurovascular or tendon structures. The element  
8 can include an epidural needle, and wherein the surgical tools further comprise a  
9 tissue remodeling device configured for placement via the epidural needle.

10 [0091] The epidural needle can be configured for placement into the epidural space  
11 via an approach chosen from the group consisting of a posterior interspinal midline  
12 approach, a posterior paramedian interlaminar approach, a posterior translaminar  
13 paramedian approach through a hole in the lamina, a neural foramina approach around  
14 an anterior border of a facet joint, and combinations thereof. The epidural needle can  
15 include two adjacent lumens, the second lumen configured to act as a working  
16 channel for the delivery of the surgical tools into the epidural space.

17 [0092] The apparatus can have an epidural catheter configured to convert the epidural  
18 needle into a blunt tipped instrument via an epidural needle tip cover that may be  
19 opened and then pulled back to cover the needle's tip. The epidural catheter can have  
20 a fiberoptic cable for visualization. The apparatus can have an insertable and  
21 removable working channel for tool access configured for placement alongside the  
22 needle.

23 [0093] The tissue remodeling device can be chosen from the group consisting of a  
24 tissue cauterization tool, a tissue laser device, a radiofrequency delivery device, a



1 ronguer, a tissue grasper, a tissue rasp, a probe, a bone drill, a tissue shaver, a burr, a  
2 tissue sander, and combinations thereof.

3 **[0094]** The surgical tools can produce nerve stimulation. The apparatus can have a  
4 device for monitoring neural stimulation to identify when a working surface of the  
5 surgical tools is in close proximity to vulnerable neural tissue during tissue  
6 remodeling.

7 **[0100]** An apparatus for protecting adjacent structures during remodeling of spinal  
8 anatomy that impinges upon neural, neurovascular or tendon structures is disclosed.

9 The apparatus has a mechanical barrier configured for placement between tissue to be  
10 resected and the adjacent structures. The mechanical barrier can be configured for  
11 insertion through an open incision. The mechanical barrier can be configured for  
12 insertion through a working channel of an endoscope.

13 **[0101]** The apparatus can be configured for use with a visualization element. The  
14 visualization element can be chosen from the group consisting of an epidural  
15 endoscope, a fluoroscope, ultrasound, XRay, MRI and combinations thereof. The  
16 apparatus can have a nerve stimulator to facilitate proper placement of the barrier. A  
17 conductive element can be included on a tissue modification side of the barrier or on a  
18 backside of the barrier to facilitate nerve localization. A working surface of the tissue  
19 remodeling device can have neurostimulation capabilities, thereby allowing for a  
20 positive and negative control in localizing neural tissue prior to tissue removal.

21 **[0102]** The apparatus can include a monitoring technique for monitoring electrical  
22 nerve stimulation. The monitoring technique can be chosen from the group consisting  
23 of SSEPs (somatosensory evoked potentials); MEPs (motor evoked potentials); EMG;  
24 verbal inquiries of the patient's sensory experience to the electrical stimulation; visual

1 techniques, mechanical techniques, tactile techniques monitoring neuro muscular  
2 stimulation and movement, and combinations thereof.

3 [0103] The apparatus can include an element configured to provide tissue  
4 compression against surgically remodeled tissue or bone surface in a neural pathway  
5 or foramina post-enlargement. The element is configured for percutaneous placement  
6 via the epidural space, through the neuroforamen at the level to be treated for spinal  
7 stenosis, and around the facet complex or the lamina adjacent to the facet complex.

8 The element is configured to release a biologically active material for the purposes of  
9 decreasing inflammation, or promoting remodeling of soft tissue or bone growth.

10 [0104] The apparatus can be configured for tightening to a determined tension for  
11 purposes of relieving spinal stenosis. The element can include a posterior anchor  
12 having a cord or tie looped through a hole that has been drilled in the cephalad lamina  
13 of the immediately adjacent vertebrae. Tension of the element is configured to be set  
14 at a determined level by a tension gauge, or other measurement device element  
15 holding tension against tissue to be remodeled.

16 [0105] The apparatus can have a neuro foraminal compression element configured to  
17 retract and hold pressure on spinal tissue when placed under tension, in order to  
18 relieve pressure on impinged neural and vascular structures and promote tissue  
19 remodeling. The apparatus can have a tensioning device for the neuro foraminal  
20 compression element configured to secure two ends of the element together at a  
21 posterior aspect of the vertebral lamina at a desired tension by pulling the element to  
22 the desired level of tension prior to locking the opposite ends of the element together  
23 at said tension.

24 [0106] The apparatus can have a tensioning device configured to tighten a loop  
25 formed by the neuro foraminal compression element around the facet joint complex,



1 within the lateral aspect of the lamina, and configured to tighten the compression  
2 element across a locking or crimping element to a specified tension, pulling the  
3 ligamentum flavum posteriorly in the spinal canal, in the lateral recess and in the  
4 neural foramen.

5 [0107] The apparatus can have a tensioning device configured to tighten a loop  
6 formed by the neural foraminal compression element around the lamina, close to a  
7 facet joint complex, within a lateral aspect of the lamina, and configured to tighten the  
8 compression element across a locking or crimping element to a specified tension,  
9 pulling the ligamentum flavum posteriorly in the spinal canal, in the lateral recess and  
10 in the neural foramen.

11 [0108] At least one free end of the neural foraminal compression element can be  
12 configured for subcutaneous placement to facilitate future removal of the element.  
13 The compression element can be biodegradable.

14 [0109] The compression element can contain a therapeutic agent chosen from the  
15 group consisting of medications, bioactive compounds, steroids, depot steroids, anti-  
16 inflammatories, and combinations thereof. The agent can be configured for  
17 immediate release. The agent can be configured for sustained local delivery.

18 [0110] A method of altering bone or soft tissue in a patient is disclosed. The method  
19 includes placing a tissue abrasion device through tissue to be altered, holding the  
20 tissue abrasion device under tension to bring an abrasive surface of the device firmly  
21 against the tissue to be altered, and sliding the abrasive surface of the abrasive  
22 element against the tissue to be altered, thereby altering bone or soft tissue  
23 immediately adjacent to the abrasive surface. Altering can include abrading,  
24 removing, or remodeling.

1 [0111] Placing the tissue abrasion device through tissue to be altered can include  
2 placing the device through spinal tissue that impinges on neural, neurovascular or  
3 ligamentous structures in the patient's spine. Placing the tissue abrasion device can  
4 include placing the tissue abrasion device through a neural, neurovascular, or  
5 ligamentous pathway within the patient's spine, holding the tissue abrasion device  
6 under tension to bring the abrasive surface against tissue within the pathway, and  
7 where sliding includes enlarging the pathway via frictional abrasion of the tissue.  
8 Placing a tissue abrasion device through the pathway can include placing the tissue  
9 abrasion device through neural foramina of the patient's spine and around the anterior  
10 border of a facet joint. Placing the tissue abrasion device through neural foramina of  
11 the patient's spine and around the anterior border of a facet joint can include placing  
12 the device via a route chosen from the group consisting of an open surgical approach,  
13 a percutaneous approach, a posterior percutaneous approach, an interlaminar  
14 percutaneous approach, a translaminar percutaneous approach, an interspinous  
15 percutaneous approach, through the neural foramen from a lateral direction, and  
16 combinations thereof. Placing the tissue abrasion device can include placing the  
17 device within a protective sheath or cover.

18 [0112] The method can include altering spinal tissues that impinge on neural,  
19 neurovascular, or ligamentous structures in the patient's spine.

20 [0113] Enlarging the pathway can include enlarging a diseased pathway within the  
21 patient's spine.

22 [0114] Holding the tissue abrasion device under tension against tissue within the  
23 pathway can include placing an abrasive surface of the tissue abrasion device against  
24 tissue chosen from the group consisting of an anterior surface of facet joint capsule, a  
25 medial surface of facet joint capsule, a superior articular process of the facet joint,



1 ligamentum flavum, tissues attached to ligamentum flavum, extruded spinal disc  
2 material, scar tissue, and combinations thereof.

3 [0115] Sliding the tissue abrasion device against the tissue can include sliding the  
4 abrasive surface of the tissue abrasion device against the tissue. Sliding the abrasive  
5 surface can include enlarging the lateral recess, neural foramina or central spinal canal  
6 via frictional abrasion. Sliding the abrasive surface can include preferentially  
7 abrading tissue chosen from the group consisting of ligamentum flavum, bone spurs,  
8 facet capsule, superior articular process, extruded spinal disc material, scar tissue and  
9 combinations thereof that impinge on neural or vascular structures.

10 [0116] The method can include confirming proper placement of the tissue abrasion  
11 device. Confirming proper placement of the device can include confirming proper  
12 placement with a nerve stimulator. Confirming proper placement with a nerve  
13 stimulator can include confirming proper placement with a nerve stimulator having  
14 stimulation leads placed at a location chosen from the group consisting of a non-  
15 abrasive side of the tissue abrasion device, a back side of a protective sleeve or cover  
16 placed over the tissue abrasion device, an abrasive side of the tissue abrasion device, a  
17 working side of the tissue abrasion device, and combinations thereof. Confirming  
18 proper placement can include confirming placement via a modality chosen from the  
19 group consisting of fluoroscopic, MRI, CT, infrared, ultrasound imaging, surgical  
20 triangulation, and combinations thereof.

21 [0117] The method can include monitoring nerve stimulation via somatosensory-  
22 evoked potentials (SSEPs) with the nerve stimulator. The method can include  
23 monitoring nerve stimulation via motor-evoked potentials (MEPs) with the nerve  
24 stimulator. The method can include monitoring nerve stimulation via verbal patient  
25 sensory response to the nerve stimulator.

1 [0118] The method can include replacing the tissue abrasion device with a  
2 compression element that is held against altered tissue or bone.

3 [0119] Apparatus for the removal of impinging soft tissue or bone within a patient are  
4 disclosed. The apparatus can have a tissue abrasion device configured for placement  
5 through impinged tissue pathways. The tissue abrasion device can have an abrasive  
6 surface configured for placement adjacent to the impinging tissue. The impinged  
7 tissue pathways can have pathways chosen from the group consisting of neural  
8 pathways, neurovascular pathways, ligamentous pathways, and combinations thereof.  
9 The tissue abrasion device can be configured for the removal of spinal structures that  
10 impinge neural or neurovascular tissues within the patient, and wherein the tissue  
11 abrasion device is configured for placement through neural foramina of the patient's  
12 spine and around the anterior border of a facet joint.

13 [0120] The apparatus can have a protective cover disposed about the tissue abrasion  
14 device, where the protective cover is configured to limit exposure of an abrasive  
15 surface of the device to areas where tissue removal is desired. The apparatus can have  
16 a nerve stimulator in communication with the tissue abrasion device to facilitate  
17 proper placement of the device.

18 [0121] The apparatus can have a conductive element disposed on an abrasive surface  
19 of the device to enable nerve localization by sending a small electrical current through  
20 the conductive element.

21 [0122] The apparatus can have an epidural needle, where the tissue abrasion device is  
22 configured for placement through the epidural needle.

23 [0123] The apparatus can have a visualization element for direct visualization of the  
24 neural foramina. The apparatus can have a neural foramina compression element.



1 [0124] The compression element can be configured to promote hemostasis and  
2 desired tissue remodeling during healing. The element can be configured to be left in  
3 place after being secured with adequate tension against tissue abraded with the tissue  
4 abrasion device. The compression element can be configured to protect a tissue  
5 surface abraded with the device. The compression element can be configured to  
6 prevent adhesions during healing. The compression element can be configured to  
7 protect vulnerable structures adjacent to tissue abraded with the tissue abrasion device  
8 from an inflammatory response triggered by tissue abrasion.

9 [0125] The tissue abrasion device can be configured for placement in front of, across,  
10 and then behind tissue to be abraded, such as through a naturally occurring or  
11 artificially created anatomical foramen or tissue pathway. The abrasive surface can  
12 be disposed on all or part of one side of the tissue abrasion device. The abrasive  
13 surface can be disposed on an element chosen from the group consisting of a length of  
14 ribbon, strap, cable, belt, cord, string, suture, wire and combinations thereof. The  
15 ends of the device can be configured for manual grasping. The apparatus can have a  
16 handle to which ends of the device are attached for manual grasping. The device can  
17 be configured for attachment to an electromechanical power-driven device.

18 [0126] The device can be configured to be placed under tension in order to bring the  
19 abrasive surface into contact with tissue to be removed. The abrasive surface can be  
20 configured to be pulled against tissue to be removed. The abrasive device can have  
21 multiple abrasive elements with different abrasive surfaces, configured for  
22 interchangeable use. The multiple abrasive elements can have varying grades of  
23 abrasive material. The multiple abrasive elements can have different grooves,  
24 patterns of grooves, or material patterns on the abrasive surface to facilitate  
25 preferential abrasion of tissue at desired locations. The patterns of grooves can have

1 diagonal parallel grooves that preferentially move the abrasive element towards one  
2 direction on the surface being abraded as the abrasive element is pulled in one  
3 direction, and towards an opposing direction as the abrasive element is pulled in a  
4 second direction. The multiple abrasive elements can have different shapes that guide  
5 the extent and location of tissue removal.

6 [0127] The apparatus can be configured to carry debris away from the site of tissue  
7 removal.

8 [0128] The tissue abrasion device can vary in profile along its length. The tissue  
9 abrasion device can have openings that facilitate passage of debris behind the device  
10 for storage or removal.

11 [0129] The apparatus can have a monitor for monitoring electrical nerve stimulation  
12 with the nerve stimulator. The monitor can be configured to monitor a feedback  
13 chosen from the group consisting of SSEPs, MEPs, EMG, verbal communication of  
14 patient sensation, visual monitoring, mechanical monitoring, tactile means,  
15 monitoring of neuromuscular stimulation and movement, and combinations thereof.

16 [0130] The compression element can be biodegradable. The compression element  
17 can contain a therapeutic agent configured for delivery to abraded tissue or adjacent  
18 neural and neurovascular structures. The therapeutic agent can be a medication,  
19 bioactive compound, steroid, depot steroid, anti-inflammatory, adhesion barrier,  
20 procoagulant compound, or combination thereof.

21 [0131] The protective cover can be attached, external to the patient, to a suspension  
22 system that includes elements to firmly and individually grasp each end of the cover  
23 and hold it in position under tension against the tissue surface to be abraded, with an  
24 open portion of the cover exposing the abrasive element directly over tissue to be  
25 abraded. The protective cover can be configured to protect a non-abrasive side of the



1 tissue abrasion device. The protective cover can have channels along its lateral  
2 aspects for the insertion and sliding of the tissue abrasion device. The protective  
3 cover can include channels along its lateral aspects for the insertion and sliding of a  
4 second protective cover configured for placement between an abrasive surface of the  
5 tissue abrasion device, and tissue adjacent to tissue to be abraded with the abrasive  
6 surface.

7 [0132] Apparatus for selective surgical removal of tissue is disclosed. The apparatus  
8 can have an access element, a neural protection element, and a tissue removal device.  
9 The apparatus can have a neural localization element. The neural localization element  
10 can be integrated into the neural protection element. The apparatus can have debris  
11 removal elements. The apparatus can have hemostasis elements.

12 [0133] The access element can be a cannulated probe, ball-tip probe, elevator,  
13 epidural needle, epidural probe, epidural endoscope, curved tube, curved cannula,  
14 guide wire, straight guide wire, curved guide wire, or combination thereof.

15 [0134] The neural protection element can be an element configured for delivery via  
16 the access element. The neural protection element can be configured for  
17 transforaminal placement between impinging tissue and a nerve root. The access  
18 element can be configured for transforaminal placement. The neural protection  
19 element can have a sheath having a window. The tissue removal device can be  
20 configured for placement within the sheath such that tissue removal elements  
21 disposed on a tissue removal surface of the device are locally exposed within the  
22 window. The window can be configured for transforaminal placement.

23 [0135] The tissue removal device can be configured for transforaminal placement  
24 between the neural protection element and the impinging tissue. The tissue removal  
25 device can be a tissue removal surface having tissue removal element configured to

1 remove the impinging tissue. The tissue removal elements can be powered tissue  
2 removal elements, non-powered tissue removal elements, mechanical tissue removal  
3 elements, cutting tissue removal elements, abrasive tissue removal elements,  
4 electrosurgical tissue removal elements, blades, punched features, stamped features,  
5 etched features, ground features, sharpened features, electrodes, monopolar  
6 electrodes, bipolar electrodes, or combinations thereof.

7 **[0136]** A method for selective surgical removal of tissue is disclosed. The method  
8 can include accessing a spinal neural foramen having impinging tissue, placing a  
9 neural protection element transforaminally between the impinging tissue and an  
10 underlying nerve root, placing a tissue removal device transforaminally between the  
11 impinging tissue and the neural protection element; and selectively removing the  
12 impinging tissue with the tissue removal device.

13 **[0137]** Accessing the spinal neural foramen can include accessing the neural foramen  
14 via an open surgical approach. Accessing the spinal neural foramen can include  
15 accessing the neural foramen via a percutaneous approach. Accessing the spinal  
16 neural foramen can include placing a guide wire transforaminally.

17 **[0138]** Placing the neural protection element transforaminally can include placing the  
18 neural protection element via the guide wire. Placing the tissue removal device  
19 transforaminally can include placing the tissue removal device via the neural  
20 protection element.

21 **[0139]** Selectively removing the impinging tissue can include mechanically cutting  
22 the tissue. Selectively removing the impinging tissue can include mechanically  
23 abrading the tissue. Selectively removing the impinging tissue can include  
24 electrosurgically removing the tissue.



1 [0140] The method can include, prior to selective removal of the impinging tissue,  
2 confirming proper placement of the neural protection element and the tissue removal  
3 device. Confirming proper placement can include localizing the nerve root with a  
4 stimulation waveform.

5 [0141] The method can include removing debris generated during selective tissue  
6 removal. The method can include stanching bleeding from the site of selective tissue  
7 removal. The method can include removing the neural protection element and the  
8 tissue removal device from the neural foramen.

9 [0142] A method for selective surgical removal of tissue is disclosed. The method  
10 can include accessing impinging tissue, placing a neural protection element  
11 transforaminally between the impinging tissue and an underlying nerve root, placing a  
12 tissue removal device between the impinging tissue and the neural protection element,  
13 and selectively removing the impinging tissue with the tissue removal device.

14 [0143] An apparatus for selectively removing a first tissue adjacent to a second tissue  
15 is disclosed. The apparatus can have a tissue removal device and a tissue protection  
16 device, where the tissue protection device can have a first side and a second side,  
17 where the first side is configured to deliver a first electrical stimulation, and the  
18 second side is configured to deliver a second electrical stimulation. The apparatus can  
19 have an atraumatic access device.

20 [0144] The tissue protection device can be configured to prevent the removal of the  
21 second tissue. The tissue removal device can have an RF device. The tissue removal  
22 device can have an electrical textile conductor. The tissue removal device can have  
23 an ablation needle. The tissue removal device can have a conductive wire loop. The  
24 tissue removal device can have a mechanical tissue removal device. The tissue  
25 removal device can be slidably attached to the tissue protection device. The tissue

1 removal device can be attached by a rail to the tissue protection device. The  
2 mechanical tissue removal device can be configured to reciprocate to remove tissue.

3 [0145] An apparatus for selectively removing a first tissue adjacent to a second tissue  
4 is disclosed. The apparatus can have a tissue removal device comprising a first tissue  
5 removal element and a second tissue removal element, where the first tissue removal  
6 element is configured to remove tissue in a first direction, the second tissue removal  
7 element is configured to remove tissue in a second direction, and the first direction is  
8 substantially opposite the second direction. The first tissue removal element can have  
9 a first leading edge and a first scoop, the first leading edge can be adjacent or integral  
10 with the first scoop, and the first leading edge can be configured to deliver energy.  
11 The energy can have RF. The first leading edge can have a beveled configuration.

12 [0146] An apparatus for selectively removing a first tissue adjacent to a second tissue  
13 is disclosed. The apparatus can have a tissue removal device comprising a first tissue  
14 removal element, the first tissue removal element can have a first leading edge and a  
15 first scoop, the first leading edge can be adjacent or integral with the first scoop, and  
16 the first leading edge can be configured to emit energy. The first leading edge can  
17 have a dull edge.

18 [0147] The energy can have RF. The energy can have mechanical vibrations. The  
19 energy can have acoustic energy. The energy can have ultrasound energy. The first  
20 tissue and the second tissue can be spinal tissue.

21 [0148] The apparatus can have a tissue protection device comprising a first side and a  
22 second side, the first side can be configured to deliver a first electrical stimulation,  
23 and the second side can be configured to deliver a second electrical stimulation.

24 [0149] The tissue removal device can be slidably attached to the tissue protection  
25 device.



1 [0150] An apparatus for damaging a first spinal tissue and preserving a second spinal  
2 tissue adjacent to the first spinal tissue is disclosed. The apparatus can have a tissue  
3 removal device comprising a first tip and a body, the tip can be configured to transmit  
4 an energy to the first spinal tissue, and the body can be configured to not transmit  
5 energy. The energy can have RF.

6 [0151] A method for damaging a first spinal tissue and preserving a second spinal  
7 tissue adjacent to the first spinal tissue is disclosed. The method can include  
8 inserting a needle through the first spinal tissue where the needle can have a body and  
9 a tip, placing the tip into the second spinal tissue where the body is in the second  
10 spinal tissue, and emitting an energy through the tip.

11 [0152] The method can include suctioning through the tip. The body can emit no  
12 energy. The second tissue can have a tissue surface. The energy can have an  
13 electrical energy. The energy can have RF energy. The energy can have acoustic  
14 energy. The energy can have ultrasound energy.

15 [0153] A method for damaging a target spinal tissue is disclosed. The method can  
16 include deploying a tissue protection barrier adjacent to the target spinal tissue, where  
17 the tissue protection barrier can have a first side and a second side. The method can  
18 include monitoring electrical signals against the first side, delivering an electrical  
19 signal through the back side, and reciprocating a tissue removal device against the  
20 spinal tissue.

21 [0154] The tissue protection barrier can have a window, and the method can include  
22 positioning the window adjacent to the target spinal tissue. The window can be on the  
23 first side. The tissue protection barrier can have a lubricious coating.

24 [0155] The tissue removal device can be in the tissue protection barrier. The tissue  
25 removal device can be slidably attached to the tissue protection barrier. The tissue

1 removal device comprises a lubricious coating. The tissue removal device can emit  
2 an energy. The energy can have RF. The tissue removal device can have a scoop.  
3 The tissue removal device can have a spring. The method can include deploying  
4 energy to the target tissue through the spring.

5 [0156] Finally, the present invention also describes methods and apparatus that  
6 promote tissue remodeling, separate from the tissue resection or ablation. These  
7 devices tightly wrap, retract, or hold in position, under tension, impinging tissues  
8 within the spinous posterior elements.

9 [0157] It is expected that the apparatus and methods of the present invention will  
10 facilitate a minimally invasive approach to the selective elimination of pathological  
11 spinal tissue, thereby enabling symptomatic relief in patients suffering from spinal  
12 stenosis.

13

#### 14 BRIEF DESCRIPTION OF THE DRAWINGS

15 [0158] The above and other objects and advantages of the present invention will be  
16 apparent upon consideration of the following detailed description, taken in  
17 conjunction with the accompanying drawings, in which like reference characters refer  
18 to like parts throughout, and in which:

19 [0159] FIG. 1 is a cross section through the posterior aspect of the lumbar spine;

20 [0160] FIG. 2 is a sagittal section through the lumbar spine;

21 [0161] FIGS. 3 a, b, c are sagittal views through a patient's spine, illustrating a prior  
22 art method for epidural needle insertion, a loss of resistance method;

23 [0162] FIG. 3a illustrates a needle inserted to an interspinal ligament.

24 [0163] FIG. 3b illustrates constant pressure applied on the syringe plunger.

25 [0164] FIG. 3c illustrates saline injected into the epidural space.



1 [0165] FIG. 4 is a cross-sectional view through a patient's spine, illustrating two prior  
2 art variations of the method of FIGS. 3 a, b, c;

3 [0166] FIG. 5 is a cross-sectional view through a patient's spine, illustrating a prior  
4 art open surgical technique for neuroforaminal decompression;

5 [0167] FIG. 6 is an illustration of standard Touhy epidural needle tips;

6 [0168] FIGS. 7 are schematic side views illustrating a method and apparatus, in  
7 accordance with the present invention, for covering with a cap and blunting the sharp  
8 tip of the epidural needle post-insertion;

9 [0169] FIGS. 8 are also a schematic side view of variations of the apparatus of FIGS.  
10 7 with a method for also limiting the depth of insertion of the cannula or needle;

11 [0170] FIGS. 9 are schematic side views illustrating a method and apparatus in  
12 accordance with the present invention for covering with a cap and blunting the tip of  
13 the epidural needle post-insertion, and optionally converting the epidural needle to an  
14 epidural endoscope, for safe further advancement of the needle into the epidural  
15 space;

16 [0171] FIGS. 10 are also a schematic side view of variations of the apparatus of  
17 FIGS. 9;

18 [0172] FIGS. 11 are also a schematic side view of variations of the apparatus of  
19 FIGS. 7;

20 [0173] FIGS. 12 are also a schematic side view of variations of the apparatus of  
21 FIGS. 9;

22 [0174] FIGS. 13 a, b, c are schematic side views of variations of the apparatus of  
23 FIGS. 7 or 9;

24 [0175] FIGS. 13 d, e are schematic side views of an epidural portal over needle  
25 apparatus, as shown in FIGS 13 a, b, c; with a distal anchor engaged anterior to the

1 ligamentum flavum, when the portal has been inserted over the needle, into the  
2 epidural space;

3 [0176] FIGS. 14 is a schematic side view of variations of the apparatus of FIGS. 9;  
4 [0177] FIG. 15a is a schematic side view, partially in section, of variations of the  
5 apparatus, illustrating methods of safely utilizing the apparatus for safe placement and  
6 use of surgical tools in or around the epidural space;

7 [0178] FIG. 15b is a side view, partially in section, illustrating a method and  
8 apparatuses for safe placement of a tool or working channel into the epidural space;

9 [0179] FIG. 16 is a side view illustrating apparatuses that include a double barreled  
10 epidural needle, with the epidural needle as the most distal point, and with the  
11 working channel the more proximal tip. This system may also be converted to an  
12 endoscope and may be used for safe placement of instruments into the epidural space;

13 [0180] FIGS. 17-19 are cross-sectional views through a patient's spine, illustrating a  
14 method and apparatus for placement of a double barreled epidural needle or  
15 endoscope, the sharp tip of which has been covered in FIG 18, and thereby blunted,  
16 for safe advancement towards the lateral recess and neural foramina. The blunted  
17 epidural needle apparatus may contain a fiberoptic cable for direct visualization, in a  
18 preferred embodiment;

19 [0181] FIG. 20 is a cross-sectional view through a patient's spine that illustrates a  
20 method, following FIGS. 17-19, for placement of a working backstop or barrier into  
21 the lateral recess and/or neural foramina. The barrier or backstop may contain  
22 conductive elements for nerve stimulation and neural localization;

23 [0182] FIGS. 21-22 are cross-sectional views through a patient's spine that illustrate  
24 alternative methods and apparatuses for placement of a working backstop or barrier to  
25 enable safe tissue resection, ablation, abrasion or remodeling;



1 [0183] FIG. 23 is a cross-sectional view through a patient's spine that illustrates a tool  
2 inserted through the working channel (example shows a shaver or burr), with its tip in  
3 position for tissue removal or debridement, adjacent to a protective working backstop  
4 or barrier.

5 [0184] FIGS. 24 are schematic views of a working backstop or barrier apparatus,  
6 including an optional rail for controlled tool placement in relation to the barrier, and  
7 an optional conductive element for neural stimulation and localization.

8 [0185] FIG. 24b is a frontal view from above;

9 [0186] FIG. 24c is a front view;

10 [0187] FIG. 24d is a frontal view of the working backstop or barrier apparatus folded  
11 for compact delivery;

12 [0188] FIG. 25 is a cross-sectional view through a patient's spine that illustrates a  
13 methods and apparatuses for providing neural stimulation and neural localization,  
14 within a working backstop or barrier, and/or within a tool (a bone burr placed adjacent  
15 to a spinal bone spur in the lateral recess, in this illustrative example), for safety in  
16 tissue resection, abrasion or remodeling;

17 [0189] FIG. 26A is a schematic view of apparatus of the present invention for  
18 obtaining open surgical access;

19 [0190] FIGS. 26B-26E are cross-sectional views through a patient's spine, illustrating  
20 open surgical methods of using the apparatus of FIG. 26A to obtain access;

21 [0191] FIGS. 27A and 27B are cross-sectional views through a patient's spine,  
22 illustrating a variation of the methods and apparatus of FIGS. 26

23 [0192] FIGS. 28-35 are cross-sectional views through a patient's spine, illustrating a  
24 method and apparatus for selective surgical removal of tissue;

1 [0193] FIGS. 36-39 are cross-sectional views through a patient's spine, illustrating a  
2 variation of the method and apparatus of FIGS. 28-35;

3 [0194] FIGS. 40a-40d are cross-sectional views through a patient's spine, illustrating  
4 another variation of the method and apparatus of FIGS. 28-35;

5 [0195] FIGS. 41 are a detailed view and a close up of the cross section of the  
6 apparatus used in FIG. 40d;

7 [0196] FIG. 42 is an alternative embodiment of the apparatus of FIG. 41;

8 [0197] FIGS. 43-48 are partial cross-sectional views through a patient's spine,  
9 illustrating a double barrel system used with additional methods and apparatus for  
10 placement of an abrasion apparatus through the neural foramina for selective surgical  
11 removal of tissue;

12 [0198] FIGS. 49-61 are cross-sectional views through a patient's spine, illustrating a  
13 variation of the methods and apparatus of FIGS. 43-48;

14 [0199] FIG. 62 is a cross-sectional view through a patient's spine, illustrating a  
15 methods and apparatus that, under tension, anchors and suspends the working sheath  
16 or protective sleeve that covers the neuroforaminal abrasion device;

17 [0200] FIG. 63 is a cross-sectional view through a patient's spine, illustrating a  
18 method and apparatus that, under tension, provides a percutaneous compression  
19 dressing over the abraded area. In this illustration, the compression dressing is the  
20 same working sheath or protective sleeve that had covered the neuroforaminal  
21 abrasion device;

22 [0201] FIG. 64 is a schematic cross-sectional view through a patient's spine,  
23 illustrating a method and apparatus for achieving neural localization during use of the  
24 tissue abrasion apparatus;



1 [0202] FIGS. 65 are schematic views of additional apparatus, showing a spool or reel  
2 to reel configuration of a portion of the device that may be utilized for selective  
3 surgical removal of tissue;

4 [0203] FIGS. 67-73 are schematic cross-sectional views through a patient's spine of a  
5 method and apparatus for a posterior midline or paramedian approach to placement of  
6 a posterior elements compression, retraction or retention device around the facet  
7 complex, through the neural foramina;

8 [0204] FIGS. 74 are schematic cross-sectional views through a patient's spine  
9 illustrating a posterior lateral approach to placement of the spinal compression,  
10 retraction or retention apparatuses;

11 [0205] FIGS. 75 are schematic cross-sectional views through a patient's spine of a  
12 fully implanted compression or retraction remodeling apparatus or compression  
13 dressing apparatus;

14 [0206] FIG. 76 is a schematic cross-sectional view through a patient's spine of an  
15 apparatuses for a compression remodeling strap integrated with a working backstop or  
16 barrier.

17 [0207] FIG. 77 is a cross-sectional view through a patient's spine that shows a facet  
18 drill with a ligament retraction device around a working backstop, and demonstrates a  
19 image guided drill used in conjunction with the backstop;

20 [0208] FIGS. 78-81 are schematic views of cable strap configurations for temporary  
21 removable, permanent, or biodegradable compression dressings or remodeling tools;

22 [0209] FIGS. 82-83 are schematic cross-sectional and lateral views through a  
23 patient's spine of apparatuses for temporary or permanent retraction and retention of  
24 the ligamentum flavum;

1 [0210] FIGS. 84 are sagittal cryosection images through 3 cadaveric spines (courtesy  
2 of Wolfgang Rauschning, MD) that illustrate pathological anterior bulging and  
3 “buckling” of the ligamentum flavum, encroaching on the spinal canal or lateral  
4 recess, a frequent contributing factor in spinal stenosis. In circumstances when  
5 similarly protruding ligamentum flavum impinges neural and neurovascular structures  
6 in the spinal canal, lateral recess, or neural foramina, then retraction of said ligaments,  
7 as in FIGS. 79 and 80 may be beneficial to the patient;

8 [0211] FIG. 85 are cross-sectional views through a protective sleeve or sheath,  
9 compact during insertion (b), and expanded (c) by passing the apparatus through its  
10 lumen;

11 [0212] FIGS. 86 are schematic views of additional apparatus that may be utilized for  
12 selective surgical removal of tissue;

13 [0213] FIGS. 87 are schematic views of additional apparatus that may be utilized for  
14 selective surgical removal of tissue, and subsequently as a compression dressing, with  
15 the ability to act as a therapeutic drug depot;

16 [0214] FIGS. 88 are schematic views of additional apparatus that may be utilized for  
17 selective surgical removal of tissue;

18 [0215] FIG. 89 is a schematic view of an additional apparatus that may be utilized for  
19 selective surgical removal of tissue;

20 [0216] FIGS. 90 are schematic views of close-ups of the additional apparatus that  
21 may be utilized for selective surgical removal of tissue of FIG. 89;

22 [0217] FIGS. 91A-91E are, respectively, a detail view of the working side of a neural  
23 protection element, a detail view of the tissue removal surface of a tissue removal  
24 device, an assembly view of the neural protection element and the tissue removal  
25 device, a cross-sectional view of the element and device along section line A--A of



1 FIG. 91C, and a cross-sectional view of the element and device along section along B-  
2 -B of FIG. 91D;

3 [0218] FIGS. 92A-92H are schematic views of additional variations of mechanical  
4 tissue removal elements;

5 [0219] FIGS. 93A-93C are views of a variation of the tissue removal device  
6 comprising electrosurgical tissue removal elements;

7 [0220] FIG. 94 is a schematic view of another variation of electrosurgical tissue  
8 removal elements;

9 [0221] FIG. 95 is a schematic view of another variation of electrosurgical tissue  
10 removal elements;

11 [0222] FIG. 96 is a schematic view of a variation of the tissue removal device  
12 comprising both mechanical and electrosurgical tissue removal elements;

13 [0223] FIG. 97 is a cross-sectional view through a patient's spine, illustrating a  
14 variation of methods and apparatus for selective electrosurgical removal of tissue;

15 [0224] FIGS. 98A-98C are schematic views of a depth-limited variation of the tissue  
16 removal device;

17 [0225] FIGS. 99A and 99B are schematic views of a fenestrated, depth-limited  
18 variation of the tissue removal device;

19 [0226] FIG. 100A and 100B are a schematic view and a detail view of another  
20 variation of the tissue removal device.

21 [0227] FIG. 101 is a schematic view of a variation of the tissue removal device  
22 configured for selective removal of tissue via manual reciprocation;

23 [0228] FIG. 102 is a schematic view of a variation of the tissue removal device  
24 configured for unidirectional removal of tissue;

1 [0229] FIGS. 103 – 108 are schematic lateral views of additional apparatus that may  
2 be utilized for visualization in the epidural space, enabling the selective surgical  
3 removal of tissue;

4 [0230] FIGS. 103 illustrate an embodiment of an endoscope in a clear tipped cannula;  
5 [0231] FIGS. 104 illustrate an embodiment of a 0-degree endoscope rotated in unison  
6 with a curved, clear tipped cannula;

7 [0232] FIGS. 105 illustrate an embodiment of a 30-degree endoscope rotated  
8 separately inside of a clear tipped cannula;

9 [0233] FIGS. 106a-c illustrate various embodiments of a clear tipped cannula with a  
10 clear shaft;

11 [0234] FIGS. 106d-f illustrate various embodiments of a clear tipped cannula with an  
12 opaque shaft;

13 [0235] FIGS. 107 illustrate an embodiment of a clear tipped cannula with a flexible  
14 neck;

15 [0236] FIG. 108 illustrates an embodiment of an endoscope with a built-in clear cover  
16 (e.g., a combination device embodiment);

17 [0237] FIGS. 109 – 114 are schematic lateral views of similar apparatus for  
18 visualization in the epidural space, along with additional method and apparatus that  
19 enable the safe placement and use of tools for selective surgical ablation, resection,  
20 abrasion and remodeling of tissue;

21 [0238] FIGS. 109 illustrate various embodiments of a clear tipped cannula with a free  
22 adjacent tool;

23 [0239] FIGS. 110 illustrate various embodiments of a clear tipped cannula with an  
24 attached adjacent tool;



1 [0240] FIG. 111a illustrates an embodiment of a clear tipped cannula with a working  
2 channel for a tool;

3 [0241] FIG. 111b illustrates an embodiment of a clear tipped cannula with a nerve  
4 stimulator at a working channel exit;

5 [0242] FIGS. 112 illustrate various embodiments of cannulas with a nerve stimulator  
6 at the tip (e.g., EMG sensors peripherally placed);

7 [0243] FIGS. 113 illustrate various embodiments of a clear tipped cannula with a  
8 nerve stimulator at a tip of the free tool; and

9 [0244] FIGS. 114 illustrate various embodiments of a clear tipped cannula with a  
10 nerve stimulator at a tip of the free or attached tool.

11 [0245] FIGS. 115-116 are cross-sectional views through the lumbar spine, illustrating  
12 a standard method for epidural needle and epidural catheter placement;

13 [0246] FIGS. 117-118 are cross-sectional views through the lumbar spine, illustrating  
14 a method and apparatus that converts a sharp epidural needle into an atraumatic blunt  
15 instrument in the epidural space;

16 [0247] FIG. 119 is a cross-sectional view through a patient's spine, illustrating  
17 advancement of the instrument into the lateral recess of the spine, adjacent or into the  
18 neural foramina;

19 [0248] FIG. 120 is a cross-sectional view through a patient's spine, illustrating  
20 attachment of a neural stimulation and localization device to the apparatus (The neural  
21 monitoring apparatus is not shown);

22 [0249] FIGS. 121-122 are cross-sectional views through a patient's spine, illustrating  
23 advancement and in-situ enlargement of the tissue protection barrier through the  
24 lateral recess and neural foramina, between the tissue to be removed and the neural  
25 structures to be protected;

1 [0250] FIG. 123 is a cross-sectional view through a patient's spine, illustrating  
2 placement of the energy delivery apparatus into the protected working tissue removal  
3 space created by the neural protection element;

4 [0251] FIG. 124 is a cross-sectional view through a patient's spine, illustrating  
5 delivery, to the pathologically impinging tissue, of energy (e.g. electrical, bipolar,  
6 monopolar, thermal, laser, cryo, ultrasound, microwave, etc.) in order to vaporize,  
7 destroy, break up, liquefy, or otherwise change the impinging tissue modulus for  
8 subsequent ease of removal of said pathologically impinging tissue;

9 [0252] FIGS. 125-126 are cross-sectional views through a patient's spine, illustrating  
10 the advancement and retraction of a guillotine blade through the pathologically  
11 impinging tissue and/or debris, for removal;

12 [0253] FIGS. 127-130 are cross-sectional views through a patient's spine, illustrating  
13 one example of possible steps for the removal of the energy delivery apparatus, neural  
14 protection element, epidural catheter and needle.

15 [0254] FIG. 131 is a close-up view of an embodiment of section A of Figure 121.

16 [0255] FIGS. 132 and 133 illustrate close-up perspective views of an embodiment of  
17 the working surface of the tissue protection barrier.

18 [0256] FIGS. 134 and 135 illustrate close-up views of various embodiments of the  
19 needle tip.

20 [0257] FIGS. 136 and 137 are cross-sectional views through a patient's spine,  
21 illustrating placement of the energy delivery apparatus into the protected working  
22 tissue removal space created by the neural protection element;

23 [0258] FIG. 138 is a close-up view of an embodiment of section B of Figure 137.



1 [0259] FIG. 139 is a cross-sectional view through a patient's spine, illustrating a  
2 method of delivering energy (e.g. electrical, bipolar, monopolar, thermal, laser, cryo,  
3 ultrasound, microwave, etc.) to the pathologically impinging tissue;

4 [0260] FIGS. 140-142 are cross-sectional views through a patient's spine, illustrating  
5 an embodiment of a method of the retraction and removal of the surgical removal  
6 apparatus;

7 [0261] FIG. 143 is a close-up view of an embodiment of section C of Figure 139.

8 [0262] FIG. 144 is a cross-sectional view of an embodiment of the tissue removal  
9 apparatus.

10 [0263] FIG. 145 is a cross-sectional view of an embodiment of a method for using the  
11 tissue removal apparatus.

12 [0264] FIGS. 146-153 illustrate embodiments of fixed rail shields, demonstrating  
13 dilating tips, distal wire anchor systems for added ability to pull tension across the  
14 impinging tissue, and combined proximal and distal wire anchoring systems.

15 [0265] FIGS. 154-157 illustrate an embodiment of a method for using a flexible or  
16 spreadable tissue protection barrier, demonstrating dual rails, which are curved for  
17 advancement through the neural foramina, and, in this example, are joined by  
18 expandable back side protection. This example depicts the tissue removal element  
19 serving also as a dilator for the rail and neural barrier system, as it is advanced  
20 between the spreadable rails.

21 [0266] FIG. 158 is a side perspective view with phantom see-through lines of an  
22 embodiment of the tissue removal device.

23 [0267] FIG. 159 is a side perspective view an embodiment of the tissue removal  
24 device.

1 [0268] FIG. 160 is a reversed close-up view of the bracketed section of the tissue  
2 removal device of FIG. 159.

3 [0269] FIGS. 161 and 162 illustrate close up views of an embodiment of a method for  
4 using the tissue removal device.

5 [0270] FIGS. 163-165 illustrate close up views of various embodiments the tissue  
6 removal device.

7 [0271] FIGS. 166 and 167 illustrate close up views of an embodiment of a method for  
8 using the tissue removal device.

9 [0272] FIGS. 168-171 are cross-sectional views through a patient's spine illustrating  
10 a method for deploying the distal wire.

11 [0273] FIGS. 172-174 are close up views of an embodiment of a method for  
12 removing the tissue at, for example, section E of FIG. 171.

13 [0274] FIGS. 175-178 illustrate a method for deploying the tissue removal device.

14 [0275] FIGS. 179-180 illustrate an embodiment of section F of Figure 175.

15 [0276] FIGS. 181-187 illustrate methods for deploying the tissue removal device.

16

17

#### DETAILED DESCRIPTION

18 [0277] The present invention relates to methods and apparatus for the selective  
19 surgical alteration (e.g., removal and remodeling) of tissue that impinges upon spinal  
20 neural or vascular structures, with particular attention towards avoiding injury and/or  
21 trauma to the affected or adjacent neural, vascular and neurovascular structures. More  
22 particularly, the present invention relates to methods and apparatus for spinal lateral  
23 recess 108 and neural foraminal 110 enlargement, and central canal enlargement of  
24 the spine, in cases of neurovascular impingement, through a novel approach to  
25 selective and safe enlargement of the pathologically narrow spinal neural foramen,



1 impinged lateral recess 108 and/or compromised central spinal canal. The approach  
2 includes alteration of the tissues that pathologically impinge neural and neurovascular  
3 structures in the spine. Impinging tissues to be removed from or remodeled in the  
4 spine's central canal, lateral recess 108, and neural foramen 110 may include, but are  
5 not limited to, ligamentum flavum 10; bone spurs or ligamentous calcifications;  
6 localized disc extrusions; enlarged facet joint complex 12, facet capsule, superior  
7 articular processes; osteophytes, and scar tissue or adhesions.

8 [0278] The variations of the invention designed to treat spinal stenosis are  
9 summarized in this paragraph, and described in greater detail in the paragraphs that  
10 follow. The methods begin with insertion of an epidural needle apparatus 2, which is  
11 converted, after placement in the epidural space, from a sharp tipped instrument, into  
12 a blunt tipped tool. The blunt tool is manipulated within the epidural space 42, either  
13 under image guidance; under direct vision with an accompanying epidural endoscope;  
14 or under direct vision when the instrument itself is given endoscopic function. The  
15 same blunt tipped epidural instrument may have an attached fixed or removable  
16 working channel. An additional apparatus of the current invention, a working  
17 backstop or barrier 134 that serves to protect adjacent vulnerable structures during the  
18 procedure, may subsequently be inserted into the epidural space 42, as well as through  
19 the neural foramina 110, through the needle or endoscope or an adjacent working  
20 channel. Safe resection, ablation, and remodeling may be further ensured through the  
21 integration into the invention of electrical neural stimulation and monitoring for  
22 localization, optionally available through nerve stimulation functionality in the  
23 epidural instrument; the working tools used through the needle or working channel;  
24 and/or the working backstop. Finally, further variations of the device and method  
25 enable the surgeon to remodel stenotic spinal anatomy, either after tissue resection or

1 as a stand-alone procedure, through the placement of devices for holding, retracting or  
2 retaining anatomic structures away from vulnerable neural and neurovascular  
3 structures within the posterior elements of the spine.

4 [0279] FIG. 1 shows the posterior elements of the spine in axial cross section. The  
5 epidural space 42 in the spine is consistently more accessible in its posterior most  
6 aspect, a fat filled zone most popular for safe epidural needle 2 placement, posterior to  
7 the dura mater 46. The dura 46 covers and contains the central neural elements of the  
8 spine, including the spinal cord, nerve roots, and spinal fluid.

9 [0280] FIG. 2 illustrates the spine in sagittal section. The spine comprises multiple  
10 vertebrae each having spinous process 80, transverse processes, facet joint complex  
11 12, and neural foramen 110. Pedicles form inferior and superior boundaries of the  
12 neural foramen 110 and are connected to the spinous process by lamina. Interspinous  
13 ligaments 78 extend between adjacent spinous processes 80, while ligamentum  
14 flavum 10 connect adjacent lamina 122 and are separated from dura mater 46 and  
15 spinal cord (not shown) by epidural space 42. Dura mater 46 encapsulates the spinal  
16 cord as it runs down the spinal canal, as well as nerve roots 62 as they exit through the  
17 lateral recesses 108 and neural foramen 110. Vertebral bodies and spinal discs are  
18 disposed anterior of the spinal cord.

19 [0281] FIGS. 1 and 2 show two of the most important anatomic structures involved in  
20 the impingement of neural and neurovascular tissue in spinal stenosis - the  
21 ligamentum flavum 10 and the facet joint complex 12.

22 [0282] For posterior approaches to the lateral recess 108 and neural foramen 110, the  
23 needle 2 is inserted at or one level below the spinal interspace where tissue abrasion  
24 and removal is desired. The epidural needle 2 may be inserted into the epidural space  
25 42, midline, ipsilateral, or contralateral to the area where the spinal canal, lateral



1 recess 108 and/or neuroforaminal stenosis or impingement is to be treated. Referring  
2 now to FIGS. 3, a prior art method for epidural needle 2 insertion is shown,  
3 comprising a standard loss-of-resistance technique. Needle based device placement  
4 may be approached from either the medial or the lateral side of the neural foramen  
5 110. FIGS. 3 illustrate a midline interspinous approach to the posterior epidural space  
6 42. Using this technique, a large bore (e.g. 12 to 18 gauge) epidural needle 2 is  
7 inserted into interspinous ligaments, and is directed towards the posterior epidural space  
8 42, while fluid (e.g. sterile saline) or air is compressed within the syringe 60, meeting  
9 resistance to injection. Upon entry of the needle tip into the epidural space 42,  
10 perhaps through the ligamentum flavum 10, there is a manually perceptible “loss of  
11 resistance” to the continued pressure on the plunger of the syringe, as the compressed  
12 fluid or air easily enters the epidural space 42, without resistance, signifying correct  
13 needle tip position (i.e., placement). The epidural space 42 has a slight negative  
14 pressure. Alternative posterior epidural needle 2 entry approaches into the epidural  
15 space 42 are illustrated in FIG 4, including interlaminar paramedian and midline  
16 interspinous techniques, a preferred approach to the medial side of the neural foramen  
17 110 for epidural placement of the epidural needle 2. An alternative posterior  
18 translaminar approach, where the needle is placed through a hole in the lamina 122, is  
19 not shown. The epidural space 42 may also be entered via a more lateral,  
20 neuroforaminal approach to needle placement, as shown in FIGS. 74. When  
21 interlaminar access is not possible (e.g. unusual cases when laminae 6 are too tightly  
22 approximated, even with flexion of the back), the epidural space 42 may be entered  
23 via a translaminar burr hole using a drill designed for safe epidural entry. Each of  
24 these approaches allows placement of the tip of epidural needle in the posterior

1 epidural space 42. As discussed, percutaneous access to the lateral recess 108 and  
2 neural foramen 110 may be achieved from the epidural space.

3 [0283] With any percutaneous epidural approach, after a sterile prep and drape, the  
4 epidural needle's 2 sharp tip is inserted through the skin to perform a loss-of-  
5 resistance technique.

6 [0284] The epidural needle's 2 sharp tip is inserted through the skin until it begins to  
7 engage the interspinous ligaments 78. Subsequently, a fluid or air filled (loss of  
8 resistance) syringe 60 is depressed and will meet resistance to injection, until the  
9 needle tip is advanced, through the ligamentum flavum 10, entering the epidural space  
10 42, which actually has a slight negative pressure. There is a clear "loss of resistance"  
11 to the pressurized contents of the syringe 60, which occurs upon entering the epidural  
12 space 42, signifying correct needle tip placement.

13 [0285] When interlaminar access is not possible (e.g. unusual cases when laminae are  
14 too tightly approximated, even with flexion of the back), the epidural space 42 may be  
15 entered via a translaminar burr hole, using a drill designed for safe epidural entry.

16 Each of these approaches allows placement of the epidural needle 2 tip in the  
17 posterior epidural space 42, poised for access to the lateral recess 108 and neural  
18 foramen 110.

19 [0286] As seen in FIG. 5, the current surgical standard of care for treating  
20 neuroforaminal stenosis comprises performing an open decompression via a surgical  
21 cut-down to access the stenosed lateral recess 108 and neural foramen 110. All or a  
22 portion of the spinous process 80 or facet joint complex 12 may be removed in order  
23 to obtain access. Bone and/or ligament from the recess 108 and the neural foramen  
24 110 then may be removed with Rongeur 494. A Woodson elevator or ball-tip probe  
25 may be used to determine the adequacy of decompression.



1 [0287] This prior art surgical procedure is imprecise and may not provide for an  
2 adequate decompression due to an inability to access all of the foramen 110.  
3 Furthermore, a risk of injuring nerve root 62 exists due to a lack of neural protection.  
4 Furtherstill, instability caused by the procedure often necessitates spinal fusion.

5 [0288] After the epidural needle's 2 distal tip has been placed in the posterior epidural  
6 space 42, a specially designed epidural catheter 24 is threaded through the needle 2.  
7 Once threaded into the epidural space 42, the epidural catheter's unique epidural  
8 needle tip cover 36, located in the distal end of the epidural catheter 24 (with needle  
9 tip covering capabilities), is opened and pulled back to cover the sharp epidural needle  
10 2 tip, locked in place, and thereby converts the needle to a non-sharp instrument. The  
11 needle, thus converted, may be manipulated and advanced more safely in the epidural  
12 space. The blunted needle is subsequently advanced in a direction parallel to the dura  
13 46, in a gentle manner, taking care to avoid inadvertent dural, neural or vascular  
14 trauma. With reference to FIGS. 7, 9, 10, 11, 12, 13, and 14, methods and apparatus  
15 for protecting, covering and blunting the sharp tip of the epidural needle 2 post-  
16 insertion, and optionally converting the epidural needle 2 to an epidural endoscope 38,  
17 are described. The catheter apparatus 24 is inserted through the needle 2, and into the  
18 epidural space 42, as in FIG. 7b, 9b, 10a, 11b, 12b, 13a, and 14c. The catheter tip  
19 may be converted to the open position by one of several mechanisms, for example, the  
20 catheter illustrated in FIGS. 6 has a port 34 for injection of air or liquid, which drives  
21 (e.g., opens) the actuator for the catheter's (needle) tip (cover). By forcing air or fluid  
22 into port 34 in the epidural catheter 24, a portion of the catheter's tip 36 may be  
23 expanded, as in FIGS. 7b, 9c, 10b, 12c, 13b, or 14e, to inflate or otherwise open the  
24 needles protective cover or cap 36. In another variation, an alternative means of  
25 actuation of the cap system on the epidural catheter may be a wire or string that pulls

1 the cap into a new shape. For example, FIGS. 13 demonstrate a sliding umbrella-like  
2 mechanism for actuation of the distal epidural catheter based needle tip cover 36.  
3 FIG. 10B shows the epidural "needle cap" or "fiber cap" 36 in the opened position. In  
4 certain embodiments, the catheter may next need to be pulled back proximally  
5 through the needle 2 until, as in FIG. 10C, until the epidural needle cover 36 is  
6 engaged over the distal needle tip, protecting the dura 46, neural and vascular  
7 structures from the sharp point of the needle 2, which is no longer exposed. Markings  
8 on the catheter will demonstrate to the surgeon that the catheter is in the correct  
9 position, allowing the blunted epidural instrument to be safely advanced.

10 [0289] Once the tip of the epidural needle 2 has been blunted or capped, and is no  
11 longer sharp, the needle may be move safely advanced within the epidural space,  
12 preferably in a direction parallel to the dura 46. In one variation, the epidural needle  
13 tip is covered by the catheter based device, then is advanced through the epidural  
14 space under image guidance (e.g. fluoroscopy, CT, x-ray, MRI, Ultrasound, etc.),  
15 towards the area where tissue resection, ablation or remodeling is to be performed.

16 [0290] In an alternative variation of the method and device, as in FIGS. 9, 10, 12, and  
17 14, the epidural catheter 24, in addition to a needle tip cover, also contains a fiberoptic  
18 cable 38, which enables conversion of the epidural needle 2 into an epidural  
19 endoscope 38. The fiberoptic component 38 of the catheter provides the surgeon with  
20 an ability to directly visualize the epidural space 42. In a further variation of the  
21 method, both fiberoptic visualization and image guidance may be used concurrently.

22 [0291] In this apparatus and method for enabling safe manipulation of the apparatus  
23 in the epidural space, an epidural needle 2 is first placed in the posterior epidural  
24 space 42 in a similar manner to what was described above. With the needle tip in the  
25 epidural space 42, an epidural catheter 24 apparatus is used to deliver a cover 36 to



1 the sharp epidural needle tip, converting the needle to a blunt instrument, as shown in  
2 FIGS. 7, 10, 12, and 13, for further atraumatic advancement of the apparatus into the  
3 epidural space 42. After the catheter 24 is advanced through the epidural needle 2  
4 into the epidural space 42, as in figures 8a and 10a, a distal portion of the catheter is  
5 converted to a shape that will be used to cover the sharp epidural needle tip, as  
6 illustrated in FIG. 7b. In one variation of the catheter, conversion of the catheter tip  
7 to its new shape is triggered via the injection of fluid or air into an actuator within the  
8 catheter tip (FIGS. 7b, c). Alternative embodiments of the tip cover 36 are actuated  
9 via wire or string that is pulled to bring the tip into its new configuration, e.g. a  
10 standard umbrella-like mechanism (FIGS. 13 a, b, and c).

11 [0292] Once the cover 36 in the distal catheter 24 is opened, the catheter 24 is gently  
12 pulled back until the needle tip is covered and thereby blunted. The capped needle is  
13 next carefully advanced within the epidural space 42, between the ligamentum flavum  
14 10 and the dura 46, somewhat parallel to both, towards one of the neural foramen 110,  
15 with much less risk of inadvertent dural puncture. In order to further facilitate safe  
16 advancement of the capped needle in the epidural space 42, image guidance may be  
17 used. Additionally or alternatively, the epidural needle 2 may be converted to an  
18 epidural endoscope. Conversion to an endoscope may be performed by either  
19 converting the epidural needle 2 to an endoscope directly ("needlescope"), or by  
20 utilizing the epidural needle 2 to enable placement of an endoscope cannula or portal  
21 56, which will replace the needle 2. The needle 2 may be converted to an endoscope  
22 directly through use of the catheter 24 that is used to cover, blunt, or "safe" the  
23 epidural needle tip. The epidural catheter optionally may contain a rigid or flexible  
24 fiberoptic element 38, through which the surgeon may view the epidural space 42,

1 thereby converting the epidural needle 2 into an epidural endoscope. The tip of the  
2 fiberoptic catheter 38 would, in such a case, be clear.

3 [0293] In a further variation of the apparatus and method, an epidural portal 56 would  
4 allow interchangeable epidural endoscopes to be used to view or work within the  
5 epidural space. An epidural needle 2 may be used to place an endoscope portal 56,  
6 using one of the three following general approaches: (a) In one variation, a portal is an  
7 expandable catheter that is delivered as a catheter through the epidural needle 2; (b) In  
8 another preferred embodiment, an epidural needle 2 may be inserted into the epidural  
9 space, with a thin walled epidural cannula or portal 56 already in place over it, similar  
10 to the method and apparatus of standard intravenous cannulation with IV catheters  
11 used today. This technique would ideally be used in conjunction with the epidural  
12 needle method and apparatus, so that the needle may be advanced far enough to safely  
13 also place the neck of the cannula 56 or portal 56, which is a short distance proximal  
14 to the distal tip of the epidural needle 2, into the epidural space. In order be able to  
15 safely advance the portal 56 into the epidural space, the needle may be covered or  
16 blunted, as described above, using a catheter that does not contain a fiberoptic  
17 element, as in FIGS. 13. With the sharp tip covered, the needle may be subsequently  
18 advanced a few millimeters, until the distal tip of the portal has also been advanced  
19 into the epidural space 42; (c) In a third embodiment of the method and apparatus, the  
20 portal 56 may be inserted over a soft tipped flexible guidewire that has been placed  
21 through the epidural needle 2, analogous to the popular "Seldinger Technique" (a  
22 standard cannula over needle insertion approach to vascular access).

23 [0294] With reference to FIGS. 15, additional variations of the apparatus of FIGS. 10  
24 are described, illustrating methods of safely utilizing the apparatus, in combination  
25 with additional surgical tools. Safe tool access, for example, may be facilitated by the



1 inclusion of either a working channel 50 on epidural endoscope 56, or by sliding the  
2 tool along a rail 52 and slot 58 interface on the epidural cannula or "needlescope" 56.  
3 FIG. 15A shows tool 54 (illustratively a grasper) fitted with rail 52 that mates with a  
4 slot 58 of epidural endoscope 56, so that it may be inserted directly into the epidural  
5 space 42 and placed in the "safe zone" 44, without the need for a working channel  
6 along endoscope/needle 56.

7 [0295] In FIG. 15B, working channel 50 is disposed along epidural needle 2,  
8 "needlescope", or endoscope 56, e.g., is integrally formed with the endoscope or is  
9 positioned via a rail and slot mating, or a similar removable fastening mechanism,  
10 with the endoscope. FIG. 15B illustrates an epidural working channel 50 in place,  
11 connected to the cannula, needle, or endoscope, with its tool-presenting end adjacent  
12 to the "safe zone" 44.

13 [0296] In order to further facilitate working in the epidural space 42, the epidural  
14 portal or cannula may have, preferably close to its distal tip, an anchor system 40 to  
15 prevent said apparatus from inadvertently slipping out of the epidural space, as  
16 illustrated in FIGS. 8. The anchor 40 may be engaged towards the distal tip of the  
17 cannula or portal 56, anterior to the ligamentum flavum 10. The portal 56 may also  
18 be anchored external to the epidural space- e.g., to the patient's skin 70, or within  
19 interspinous 78 or supraspinous ligaments, as was illustrated in FIGS. 8.

20 [0297] Referring now to FIGS. 16, an additional method and apparatus for placement  
21 of the tissue modification elements is illustrated. A twin lumen epidural needle 84 is  
22 illustrated, comprising a working channel 50 adjacent to the epidural needle. The  
23 second lumen 50 serves as a working channel, or for the delivery of tools into or  
24 adjacent to the epidural space. Note that the distal beveled aperture of the working

1 channel is proximal to the epidural needle tip, and opens onto the side of the epidural  
2 needle that the epidural bevel faces.

3 [0298] Referring now to FIGS. 17-20 and 45-48, an additional method and apparatus  
4 for placement of a tissue abrasion apparatus for selective surgical removal or  
5 remodeling of tissue is described. In FIG. 17, the double lumen epidural needle  
6 apparatus 84 is positioned for advancement into the epidural space 42. FIGS. 18 and  
7 19 shows how the covered and blunt tip of the epidural needle 2, double lumen  
8 epidural needle 84, or the blunt end of the epidural endoscope 38, may be advanced  
9 into the ipsilateral or contralateral lateral recess 108, towards the neural foramen 110,  
10 in a direction parallel to both the adjacent ligamentum flavum 10 and the dura 46. In  
11 the illustrated example of the apparatus and method labeled FIG. 18, a fiberoptic  
12 element 38 has been placed within epidural needle 2, providing both a means for  
13 fiberoptic visualization of the epidural space 42 and a means to blunt the needle and  
14 thereby protect the tip of the needle from damaging the dura 46 or neural or vascular  
15 structures. In FIG. 19, the endoscope has been advanced along ligamentum flavum 10  
16 (visually a "yellow ligament") to the lateral recess 108. "Safe zone" 44 designates the  
17 area in which a medical practitioner may resect, ablate, or otherwise modify tissue  
18 safely, directly visualizing the area of tissue modification through the fiberoptic  
19 element. The second lumen 50 of the two lumen needle 84 or endoscope may be used  
20 as a working channel, or to dispense the abrasive element 14 and/or its protective  
21 sleeve 6 (FIGS. 43-48), or the working barrier 134 (FIG. 20) described in the primary  
22 patent referenced herein. After the neural foramen 110 has been cannulated with a  
23 non-sharp curved needle 22 or catheter (FIG. 43), and after the flexible, sharp, straight  
24 needle or wire 2 has been passed through the curved needle 22 until its tip is advanced  
25 through the skin in the patient's back (FIG. 43), the abrasion apparatus 14 and/or its



1 sleeve or cover 36 are pulled through the neural foramen 110, as illustrated in FIGS.  
2 45-48. The curved needle 22 or tube may, for example, be fabricated from spring  
3 steel, Nitinol, or other memory material that will allow it to be inserted through a  
4 straight needle, but to return to a fixed curve upon exiting the straight epidural needle  
5 2 or working channel 50. The curved needle 16 optionally may be steerable.  
6 Preferably, the curved needle tip is not sharp, but is rounded or designed in other  
7 fashions less likely to cut tissue, in order to reduce a risk of neural or vascular  
8 damage.

9 [0299] In yet an additional embodiment of the invention (“portal over epidural  
10 needle” variation), an epidural portal 56 may be inserted into the epidural space as a  
11 catheter over the epidural needle 2 (as in FIGS. 13), similar to the design for  
12 placement of standard intravenous catheters used today. With such an approach,  
13 advancing the blunted needle (sharp tip covered) by several millimeters will also  
14 bring the distal tip of the portal into the epidural space 42. Subsequently, the needle  
15 may be withdrawn from the portal, which is held in place by the surgeons other hand,  
16 leaving the epidural portal in the epidural space 42 as a working channel or endoscope  
17 guide.

18 [0300] In one variation, the epidural needle 2, needle based endoscope, flexible or  
19 rigid endoscope, or portal 56 (for placement over an epidural needle) may have,  
20 preferably close to its distal tip, an (e.g., distal) anchor mechanism 40 that may be  
21 inflated or otherwise opened (e.g., in the epidural space), to help prevent inadvertent  
22 removal of the device from the epidural space 42. It is expected that utilization of an  
23 anchor anterior to, or within, the ligamentum flavum 10, will prevent the portal from  
24 being pulled inadvertently through the ligamentum flavum 10, and will enhance the  
25 reliability and safety of epidural access for minimally invasive endoscopic surgery.

1 FIGS. 8 illustrates a distal epidural anchor 40. FIGS. 8 also illustrates that the portal,  
2 needle, or endoscope may include a proximal anchor or lock 28 (e.g., to anchor on the  
3 skin) that may be advanced from the proximal end of the device (skin side), in order  
4 to help to prevent the percutaneous device from advancing further into the epidural  
5 space than is desired (as in FIG 8b).

6 [0301] FIGS. 15 illustrates additional methods of safely utilizing a blunted epidural  
7 apparatus in conjunction with additional surgical tools. Safe tool access may, for  
8 example, be facilitated with either a fixed working channel 50, as shown in FIG. 16,  
9 or by the creation of a rail 52 and slot 58 interface on the tool or epidural endoscope,  
10 cannula or “needlescope” 56, as shown in FIG. 15b. FIG. 15a shows a tool 54  
11 (illustratively a grasper) fitted with a rail 52 that mates with a slot 58 of epidural  
12 endoscope 56, so that it may be inserted directly into the epidural space 42 and then  
13 advanced until it is placed in the “safe zone” 44 (e.g., for tissue resection or  
14 modification, on an opposite side of the epidural tissue), without the need for a  
15 working channel along endoscope/needle. The part of the epidural tool that is  
16 expected to be in direct contact with the impinging spinal tissues that the surgeon  
17 intends to modify provides an ideal location for neural stimulator lead placement 130.  
18 In the example illustrated in FIG 15a, an insulated tool shaft is combined with a  
19 conductive surface 130 on the tip of the grasping tool 54, to be used for neural  
20 stimulation. (note: the use of neural stimulation with sensorimotor monitoring, for  
21 neural localization, in conjunction with the current invention, will be discussed later  
22 in this document)

23 [0302] In one variation, the epidural needle is curved towards its distal end, e.g., into  
24 a hockey stick shape. In a curved configuration, the lumen exits the bevel, distal to,  
25 and on the concave side of the bend in the needle’s distal shaft. With such a



1 configuration, a “safe zone” 44 is created by inserting the needle so that the side  
2 opposite the bevel (convex side of the bend) is in direct contact with the dura 46, and  
3 the lumen, on the concave side of the bend, faces the ligamentum flavum 10. This  
4 configuration provides a “safe zone” 44, where tools, or a working channel 51, may  
5 be reliably placed on the needle side opposite the dura 46.

6 [0303] In FIG. 15b, a removable working channel 51 is disposed along epidural  
7 needle 2 /endoscope 56, e.g., is integrally formed with the endoscope or is positioned  
8 via a rail 52 and slot 58 mating with the endoscope 56. FIG. 15b illustrates an  
9 epidural “needlescope” 56 or endoscope cannula with the working channel 51 in  
10 place, with its tool-presenting end adjacent to the “safe zone”. In FIG. 16, a double  
11 barrel epidural needle 164 is illustrated, comprising a fixed working channel 50  
12 adjacent to the epidural needle. Needle 164 comprises first lumen 2 and second  
13 lumen 50. First lumen 2 extends distally of second lumen 50 and terminates at  
14 sharpened distal tip. Two variations of the needle are illustrated in FIG. 16.

15 [0304] Referring now to FIGS. 17-20, an additional method and apparatus for  
16 selective surgical removal of tissue is described. In FIG 17, the double lumen  
17 epidural needle apparatus is positioned for advancement into the epidural space 42  
18 (e.g., a safe triangle, an area at the most posterior aspect of the epidural space, where  
19 epidural needle tip insertion is most consistently safely performed). In FIG. 18, a  
20 catheter based fiberoptic element 132 has been placed within epidural needle,  
21 providing both a means for fiberoptic visualization of the epidural space 42 and a  
22 means to blunt the needle and thereby protect the tip of the needle from damaging the  
23 dura 46 or neural or vascular structures. In FIG. 19, the endoscope has been advanced  
24 along ligamentum flavum 10 (visually a “yellow ligament”) to the lateral recess 108.  
25 “Safe zone” 44 designates the area in which a medical practitioner may resect, ablate,

1 or otherwise modify tissue safely, under direct visualization. The second barrel or  
2 lumen 50 of the double barreled needle 84 or endoscope may be used as a working  
3 channel, or to dispense a tissue modification barrier or working barrier or backstop  
4 134.

5 [0305] In addition to the insertion of tools through the epidural needle, or through an  
6 adjacent working channel 50, the same channels may be utilized to insert a barrier  
7 134, or “working backstop” 134 (Figs. 20, 21b, 22b, 23, 24, 25), into the spine. In a  
8 further variation of the present invention, a flexible, flat, thin mechanical barrier  
9 (“working backstop”) 134 is placed between the tissue to be resected and adjacent  
10 vulnerable neural or vascular structures that are desired to be left intact and uninjured.  
11 The barrier provides protection for the dura 46, nerve root 62, dorsal root ganglia,  
12 and/or vasculature, by providing insulation and/or preventing direct contact between  
13 the tools and these vulnerable structures during tissue manipulation, resection,  
14 abrasion, or remodeling. The protective barrier may be placed between the needle  
15 based or endoscopically delivered tools and the dura 46 in the central spinal canal; in  
16 the lateral recess 108; or between the tools and the neural and neurovascular  
17 structures within the neural foramen. The barrier 134 may be placed through the  
18 neural foramen anterior to the facet joint 12, either anterior to the ligamentum flavum  
19 10 (epidural space) or within or posterior to the ligamentum flavum 10 (posterior to  
20 the epidural space). Tools that may be used in conjunction with this barrier include,  
21 but are not limited to, cautery devices (monopolar or bipolar), lasers (erbium, etc.),  
22 rasps, ronguers, graspers, burrs, sanders, drills, shavers, or probes.

23 [0306] The barrier or backstop 134 may be placed percutaneously via a needle 2,  
24 endoscope 38, or double barreled needle 84. In addition to epidural endoscopy, image  
25 guidance may be combined with the use of straight, curved, or steerable guidewires



1 for the proper placement of the barrier or backstop 134. In an open surgical variation,  
2 the barrier or backstop device 134 may be placed through the surgical incision.

3 [0307] The barrier 134 may be synthesized from one of several possible materials, for  
4 example, it may be partially fabricated from a spring steel, Nitinol, polymers, or other  
5 memory material that will allow a thin, flat barrier to be reconfigured into a more  
6 condensed configuration for passage through a straight needle (FIG. 24d), after which  
7 it returns to its desired shape (FIG. 24c) upon exiting the needle 2. The barrier 134,  
8 optionally, may be steerable.

9 [0308] As is illustrated in FIG. 25, correct anatomic placement of the backstop device  
10 134 may be validated via monitored electrical neural stimulation through the barrier  
11 device 134. Electrical nerve stimulation function may be added to the apparatus via  
12 dual conductive elements, the first placed on the working side of the backstop (or the  
13 tool used on the working side), where tissue remodeling and resection will occur. In  
14 the example illustrated in FIGS. 24, the working nerve stimulator on the working side  
15 of the barrier may be integrated with the rail 128, through which nerve stimulation  
16 may be tested before sliding the tool or sleeve over the rail for tissue modification. A  
17 conductive element (e.g., for neural stimulation) may also be placed on the non-  
18 working side of the backstop 130. To gain accuracy in neural localization, the  
19 stimulation leads on the device are separated by insulation material within the  
20 backstop material.

21 [0309] The patient may be kept awake and responsive throughout this procedure, with  
22 no neuraxial anesthetics and no systemic analgesia. In this manner, the medical  
23 practitioner may, through verbal questioning, elicit responses from the patient in order  
24 to ensure that any severe pain that would accompany undue pressure on the nerve root  
25 during placement of the tissue modification device and/or during tissue removal or

1 remodeling is immediately recognized prior to nerve injury. Alternatively, for a  
2 deeply sedated patient, or one under general anesthesia, nerve stimulation may be  
3 monitored via SSEPs or SEPs; visually (motor movement of extremities); via MEPs;  
4 and/or via EMG (motor stimulation). In one embodiment of the device, one might use  
5 a calibrated sensor, combined with computer analysis, to accurately quantify neural  
6 stimulation at different locations, in order to more accurately localize neural  
7 structures.

8 [0310] As is illustrated in FIG. 25, there should be no nerve root or dorsal root  
9 ganglion stimulation in the exact location where tissue alteration is intended to take  
10 place, when one sends appropriate small electrical current through an insulated  
11 electrode that is located on the working side of an insulated working barrier, prior to  
12 tissue modification tool placement. Correct neural location, relative to the tissue  
13 modification tools and barrier may further be ensured by the addition of focused  
14 neural stimulation functionality to accompanying surgical instruments. For example,  
15 tools used for probing, tissue resection, tissue cauterization, thermal treatment, tissue  
16 lasering, tissue manipulation, tissue retraction, and tissue abrasion may contain  
17 conductive elements for neural localization. The nerve stimulation capabilities may  
18 be used to ensure that the neural elements are not in dangerous proximity, or they may  
19 be used to assist with more concise neural localization. For instance, a probe fitted  
20 with neural stimulation capabilities in its tip may be used to identify neural structures,  
21 through monitoring of sensory or motor stimulation. However, electrical stimulation  
22 on the non-working surface of the working barrier, which is in direct or indirect  
23 contact with neural structures, should result in motor and/or sensory action potentials,  
24 which may be monitored as described above, thereby providing a positive control and  
25 assurance of proper barrier placement. For added safety, a surgical device may be



1 designed to automatically stimulate before or during resection, and may even be  
2 designed to automatically block resection when nerve stimulation has been sensed.

3 [0311] In a preferred variation, impinging spinal tissue is removed using tissue  
4 abrasion apparatus and method. Variations of the apparatus and method may be  
5 utilized during an open surgical procedure(s); during an endoscopic surgical  
6 procedure(s); or via a percutaneous (needle delivered) surgical approach. Use of a  
7 needle-based posterior interlaminar or interspinous approach, a posterior-lateral  
8 neuroforaminal approach or a minimally-invasive surgical approach for placement of  
9 the neuroforaminal abrasive tissue removal device avoids unnecessary tissue resection  
10 and minimizes tissue injury. In addition, further embodiments of the device include  
11 nerve stimulation and monitoring capabilities, which, when added to a spinal tissue  
12 alteration device, may enable the surgeon to more safely perform the procedure.

13 [0312] As discussed previously, variations of the present invention preferably provide  
14 for access, neural protection and/or decompression for treatment of spinal stenosis.  
15 With reference to FIGS. 26 and 27, methods and apparatus for obtaining access to the  
16 neural foramen utilizing open surgical variations of the present invention are  
17 described. FIG. 26A illustrates two variations of access element 184. In the first  
18 variation (26A-1), access element 184 comprises cannulated probe 186, illustratively  
19 an elevator probe having first and second lumens 188 and 190. Visualization element  
20 192, such as an epidural endoscope, may be advanced through or coupled to lumen  
21 188 to provide visualization at the distal tip of probe 186.

22 [0313] In the second variation (FIG 26A-2), probe 186 of access element 184  
23 comprises single lumen 188'. Visualization element 192, as well as cannula 194 or  
24 curved guide wire 4 described hereinafter, may be advanced through the unitary  
25 lumen – either in parallel or in sequence. Alternatively, the visualization element may

1 be omitted or may be attached directly to the probe. As will be apparent, access  
2 element 184 may comprise any desired number of lumens.

3 [0314] In FIG. 26B, the dual lumen variation of access element 184 has been placed  
4 through a surgical incision or cut-down in proximity to neural foramen 110 while  
5 under optional visualization from element 192. Visualization may facilitate access via  
6 a minimally invasive or keyhole surgical cut-down, as opposed to a fully open  
7 approach. Direct visualization alternatively or additionally may be utilized.

8 [0315] As seen in FIG. 26C, with probe 186 properly positioned, atraumatic curved  
9 tube, introducer or cannula 194 may be advanced through lumen 188' of the probe and  
10 driven laterally to cannulate the neural foramen 110. Cannula 194 optionally may be  
11 configured to deliver a stimulation waveform at or near its distal tip for monitoring  
12 proximity to the nerve root during cannulation of the foramina with the cannula. A  
13 preferably straight, flexible guide wire 4 or needle, which optionally comprises  
14 sharpened tip, then may be advanced through cannula 194 and driven posteriorly  
15 through the skin of the patient's back, as in FIG. 26D. Alternatively, a second  
16 surgical incision and or cut-down may be formed at or near the exit of the neural  
17 foramen for grasping the guide wire and pulling it through. With access guide wire 4  
18 positioned through and across the neural foramen, probe 186 may be removed, as in  
19 FIG. 26E. This leaves the guide wire 4 in place to provide access for, e.g., neural  
20 protection and tissue removal apparatus, as described hereinbelow.

21 [0316] With reference to FIGS. 27, an alternative method for obtaining open access is  
22 described. As seen in FIG. 27A, curved guide wire 22 may be advanced through  
23 lumen 188' of probe 186, such that the guide wire 22 passes through the neural  
24 foramen 110, encircles the facet 12 and reemerges in the surgical field. Guide wire 22  
25 optionally may be configured to deliver a stimulation waveform at or near its distal tip



1 for monitoring proximity to the nerve root during passage of the wire through the  
2 foramen 110. The needle may, for example, be insulated at regions other than the  
3 distal tip. With the wire encircling the facet 12, probe 186 then may be removed, as  
4 seen in FIG. 27B, leaving access guide wire 22 in place to provide access for selective  
5 removal of impinging tissue.

6 [0317] Access also may be achieved in a percutaneous fashion. For example, access  
7 may be achieved via an access element comprising an epidural needle or probe, or via  
8 an epidural endoscope having a working channel, that is positioned within the  
9 epidural space. In one variation, a curved atraumatic needle or cannula may be  
10 advanced through the percutaneous access element and driven laterally to cannulate  
11 the neural foramen. A preferably straight, flexible guide wire or needle then may be  
12 advanced through the curved needle and driven posteriorly through the skin of the  
13 patient's back. In an alternative variation, a curved guide wire may be advanced  
14 through the percutaneous access element and passed transforaminally. Percutaneous  
15 access optionally may be aided by the use of image guidance, an epidural endoscope  
16 or any other visualization technique.

17 [0318] FIG. 28 shows a percutaneous method and apparatus for obtaining access for  
18 selective surgical removal of tissue. Access element is disposed within epidural space  
19 42. Access element may comprise, for example, epidural needle 2, an epidural trocar,  
20 an epidural endoscope, etc. The needle tip is anterior to the ligamentum flavum 10,  
21 but still posterior to the dura 46 in the posterior epidural space 42.

22 [0319] FIG. 29 illustrates a preferred method of cannulating the neural foramina,  
23 where an atraumatic curved tube or cannula 16 (e.g., blunt, curved needle composed  
24 of memory material) is passed through the straight epidural needle 2 (alternatively, a  
25 stiff epidural catheter, or steerable guidewire may be inserted through the needle for

1 this step) to cannulate the neural foramen NF. The curved needle 16 is flexible  
2 enough to be passed through the straight epidural needle 2, but is made of a memory  
3 material that returns it to its curved configuration upon when it is passed into tissue.  
4 The second needle 16 (alternatively, a steerable, stiff catheter or guidewire), is  
5 advanced through the epidural space 42, possibly passing through a portion of the  
6 ligamentum flavum 10, towards and then through the ipsilateral or contralateral neural  
7 foramen 110. The surgeon may use any combination of tactile feel, image guidance,  
8 direct visualization, and/or fiberoptic visualization to ensure that the curved element  
9 16 is driven through the neural foramen, anterior to the facet (zygapophysial ) joint  
10 complex 12, but posterior to the nerve root 62 or ganglion. As discussed previously,  
11 the cannulas may be configured to stimulate and monitor response of the nerve root as  
12 a safety precaution during cannulation of the foramen.

13 [0320] Once the curved element is in position through the neural foramen, the  
14 surgeon subsequently passes a smaller gauge straight and sharp flexible guidewire 4  
15 (or needle), as in FIG. 30 through the lumen of the larger curved needle that is in  
16 position through the neural foramen 110, until it exits into the tissue lateral to the  
17 neural foramen (FIG. 30). This straight wire 4 or straight needle exits the curved  
18 element with its tip facing in a posterior or posterior-lateral direction. It is advanced  
19 further in this direction, passing to, and then through the skin of the patient's back 70,  
20 as in FIG 30. Access element 2 and cannula 16 then may be removed, as in FIG. 31,  
21 leaving access guide wire 4 in place transforaminally to provide access to the lateral  
22 recess and neural foramen.

23 [0321] As an alternative to deploying cannula 16 through access element 2, the  
24 cannula 16 may be delivered over the access element. As yet another alternative,  
25 upon placement of the access element in the epidural space, a stiff rod may be



1 advanced through the lumen of the access element, and the access element may be  
2 removed. Cannula 16 then may be deployed over the stiff rod, which then may be  
3 removed from the lumen of the cannula and replaced with guide wire 4.

4 [0322] As seen in FIG. 36, a steerable needle or wire 18 is placed through the neural  
5 foramina 110 from the lateral towards the medial side of the foramen 110. This  
6 lateral to medial neuroforaminal approach may begin with a curved, blunt wire  
7 through a straight needle (as described in the previous technique), or using a curved  
8 needle technique, a steerable guidewire technique, a needle-through-a-needle  
9 technique, or common variations thereof. While a loss of resistance technique is not  
10 as helpful with this transforaminal approach to the epidural space 42, as it was in the  
11 previously described posterior approach to the epidural space 42, the method is, in  
12 many other aspects, otherwise similar to the method illustrated in FIGS. 28-35.

13 [0323] Studies and tests may be performed to ensure that the transforaminally placed  
14 apparatus has been properly positioned between the nerve root 62 or ganglia and the  
15 facet joint complex 12. For example, imaging of the abrasion element and spinal  
16 anatomy (fluoroscopic or other imaging modalities); monitored neural stimulation  
17 through the apparatus; or direct (endoscopic or open) visualization may be utilized.

18 [0324] After proper placement has been confirmed, the curved element 16 that was  
19 used to initially cannulate the neural foramen is removed, by pulling it back out of the  
20 hub of the epidural needle 2, leaving the transforaminal wire 4 in place, as illustrated  
21 in FIG. 31. Next the epidural needle 2 may also be removed, if desired, again leaving  
22 the wire 4 in its position, through the neural foramen. As shown, both ends of the  
23 element 4 remain external to the patient, having exited the skin (percutaneous  
24 procedure) or exited the tissue through the surgical wound (open procedure).

1 [0325] With the wire in position through the neural foramina, there are multiple  
2 possible methods for replacing the wire with the abrasion apparatus. One method is  
3 illustrated in FIGS. 45-48, where the wire 4 is used to pull into position the abrasion  
4 element 14; the abrasion element sleeve or cover 6; or the abrasion element 14 and  
5 cover 6 together, as is described in greater detail below. Alternatively, as shown in  
6 FIGS. 32 and 33, separate protective sleeves or covers 36 may be passed over both the  
7 proximal and distal ends of the transforaminal wire 4. Each sleeve or cover may be  
8 advanced to the neural foramen. Next, the neuroforaminally placed wire 4 is  
9 connected distally, or proximally, to the abrasive element 14, with an abrasive surface  
10 on one side. The abrasive element 14, connected by one end to the transforaminal  
11 wire 4, is pulled through the neural foramen, and through the protective sheaths or  
12 covers 6, as in FIGS. 34 and 35, until the abrasive element has completely replaced  
13 the initially placed wire 4 (or needle). Passage of a tissue dilator over the  
14 transforaminal wire 4 or needle, may be helpful, either before or after placement of  
15 the sleeve. Protective sleeve(s) 6 illustratively are disposed over both ends of the  
16 transforaminal wire 4, in order to protect non-surgical tissues from the abrasive or  
17 cutting portion of the device, when it is pulled into place. Alternatively, a protective  
18 sleeve, which may be expandable, as illustrated in FIGS. 85, may be attached to the  
19 end of the wire and pulled through the neural foramina, thereby replacing the initial  
20 tranforaminally placed element 4.

21 [0326] In an alternative preferred embodiment, the abrasive element 14 is positioned  
22 within the protective sleeve cover 6, before or after placement of the abrasive element  
23 in position through the neural foramina. Please note that the terms "protective sleeve"  
24 and "protective cover" are used interchangeably in these descriptions of several  
25 examples of the apparatus and methods for protecting vulnerable tissue from the



1 abrasion apparatus. Embodiments of the protective methods and apparatus are  
2 illustrated in FIGS. 85-88. With the abrasive element 14 already inside the protective  
3 apparatus 94/96, with or without an opening over the abrasive surface where tissue  
4 abrasion is to be performed, the protective covering 96, with the abrasive apparatus 14  
5 already inserted within it, may be connected to one end of the needle or guidewire 4  
6 that remains in place through the neural foramen 110. In this preferred method, the  
7 combined protective sleeve 6 and the abrasive element 14 are then pulled  
8 simultaneously through the neural foramen, by pulling from the opposite end of the  
9 preliminarily placed neuroforaminal element 4, while it is removed (FIGS. 46, 47,  
10 48).

11 [0327] Once the abrasion apparatus has been properly positioned through the neural  
12 foramina 110, with its protective cover in place 6, it is ready to be tested to ensure it  
13 has been properly located. The apparatus may subsequently be utilized for tissue  
14 abrasion, tissue removal, and tissue remodeling, as will be described in detail below.  
15 Before describing tissue modification in further detail, however, we will describe  
16 alternative approaches for placement of the abrasion device into position through the  
17 neural foramina. Referring now to FIGS. 36-39, a variation of the method and  
18 apparatus of FIGS. 28-35 is described comprising an alternative approach for  
19 placement of the tissue modification device, wherein the apparatus 14 is placed from  
20 the lateral side of the neural foramen 110. As seen in FIG. 36, steerable cannula 18 is  
21 advanced through access element 2 to cannulate the foramen from the lateral towards  
22 the medial side of the foramen. (Alternatively, straight guide wire 4 may be advanced  
23 through a curved cannula 16 and driven posteriorly out the patient's back along the  
24 medial aspect of the facet, similar to above described methods for passing a guidewire  
25 through the neural foramina from its medial side).

1 [0328] Neural protection element 6 illustratively comprises a sheath having opening  
2 or window that is placed across the foramen at the position of desired selective tissue  
3 removal. The end regions of neural protection element 6 disposed outside the patient  
4 optionally may be attached or clipped together to stabilize the element and free up the  
5 medical practitioner's hands.

6 [0329] As illustrated in FIGS 57-63, a tissue removal device may be positioned  
7 between impinging tissue and the neural protection element for safe, selective  
8 removal of the impinging tissue. For example, tissue removal device 14 may be  
9 delivered through, along or in conjunction with neural protection element 6 to  
10 position the tissue removal device across the foramen between the impinging tissue  
11 and the neural protection element with tissue removal surface of device locally  
12 exposed to the impinging tissue within window of neural protection element 6. In  
13 FIG. 60, tissue removal device 14 is coupled to access guide wire 4. In FIG. 61, the  
14 tissue removal device is pulled into position by partially or completely removing the  
15 guide wire. Tissue removal device 14 alternatively may be positioned across the  
16 neural foramen in conjunction with, or at the same time as, neural protection element  
17 6, which optionally may be coupled to guide wire 4 and pulled into position.  
18 Furthermore, neural protection element 6 and tissue removal device 14 may be  
19 integrated into a single device. As yet another alternative, tissue removal device may  
20 be advanced over guide wire 4.

21 [0330] In FIG. 62 and 63, temporary stops 112 have been attached to neural  
22 protection element 6 to maintain the position of the element and free up the medical  
23 practitioner's hands, for example, for manipulation of tissue removal device 14. The  
24 stops may hold window of sheath 6 of element 14 under tension against the impinging  
25 tissue. Stops 112 may be placed or expanded, or removed or collapsed, etc., at any



1 time as desired; for example, the stops may be placed prior to positioning of tissue  
2 removal device 14 transforaminally. Stops 112 may comprise any element that  
3 temporarily maintains the position of the access element/guide wire, the neural  
4 protection element and/or the tissue removal device during a selective tissue removal  
5 procedure. As mentioned previously, the end regions of neural protection element 6  
6 alternatively or additionally may be attached or clipped to one another to stabilize the  
7 element and free up the medical practitioner's hands.

8 **[0331]** As an added safety precaution, variations of the present invention optionally  
9 may comprise neural localization elements to ensure proper positioning of the access  
10 element or guide wire, the neural protection element, and/or the tissue removal  
11 device. The neural localization elements may comprise separate elements or may be  
12 integrated with the access element, the neural protection element and/or the tissue  
13 removal device.

14 **[0332]** As seen FIG. 64, neural protection element illustratively comprises neural  
15 localization element disposed on the backside of the sheath facing nerve root 62.  
16 Element comprises a conductive element that is electrically coupled to electrical  
17 generator 114 via wires 120. Element illustratively is connected in a monopolar  
18 fashion whereby element 120 acts as an active electrode, while ground electrode 116,  
19 which is coupled to generator 114 via wire, is attached to the exterior of the patient.  
20 However, it should be understood that a bipolar neural localization element  
21 alternatively may be provided. Furthermore, neural localization element(s)  
22 alternatively or additionally may be disposed on the working side of the neural  
23 protection element, or on any other side of the neural protection element or of the  
24 tissue removal device.

1 [0333] Neural localization element may be used to ensure that neural structures and  
2 adjacent vascular structures are on the non-working or backside of neural protection  
3 element 6. Neural localization element on the backside of the sheath (i.e., the side of  
4 the sheath that contacts the nerve root when properly positioned) may be activated  
5 with a stimulation waveform to stimulate the nerve root, thereby providing a positive  
6 control that confirms placement of the backside in proximity to the nerve root.  
7 Appropriate low intensity electrical stimulation on the backside surface should result  
8 in the stimulation of sensory or motor nerves in the patient's extremity. Likewise,  
9 optional neural localization elements on the working side of the sheath (i.e., the side  
10 of the sheath that faces impinging tissue slated for removal) may be activated with a  
11 stimulation waveform in anticipation of a negative response or no neural stimulation  
12 that confirms that the working side is not in contact with the nerve root and that tissue  
13 removal may safely proceed. Neural localization elements also may be provided on  
14 sides of the sheath 6.

15 [0334] Neural stimulation may be monitored by monitoring somatosensory-evoked  
16 potentials (SSEPs), motor-evoked potentials (MEPs), and/or by looking for visual  
17 signs of muscular contraction within the extremities. SSEP, SEP, MEP or EMG  
18 feedback may be monitored and/or recorded visually, or may be monitored audibly,  
19 potentially conveying quantitative feedback related to the volume or frequency of the  
20 auditory signal (e.g. a Geiger counter-type of quantitative auditory feedback).  
21 Intensity of signal or stimulation may be monitored and used to localize the nerve  
22 during placement of neural protection element, as well.

23 [0335] Neural localization may be enabled further by the addition of surgical  
24 instruments (e.g. cautery devices, graspers, shavers, burrs, probes, etc.) that are able to  
25 selectively stimulate electrically while monitoring nerve stimulation in similar



1 fashions. Quantification of stimulation may enable neural localization. For instance,  
2 one might use a calibrated sensor input that recognizes stronger stimulation as the  
3 device is moved closer to neural structures. For added safety, tissue removal device  
4 114 may be designed to automatically stimulate before or during tissue removal, and  
5 may even be designed to automatically stop tissue removal when nerve stimulation  
6 has been sensed.

7 [0336] With reference to FIGS. 40a-40e, another variation of the method and  
8 apparatus of FIGS. 28-35 is described. In FIG. 40a, the apparatus 20 is placed from  
9 an interlaminar; a translaminar, interspinous; or a transforaminal insertion,  
10 illustratively via a paramedian, ipsilateral (i.e., medial to lateral) approach. The  
11 apparatus can be an epidural probe, which may, for example, comprise an epidural  
12 endoscope having a working channel. The apparatus can be advanced in proximity to  
13 the medial aspect of the neural foramen. A lateral to medial transforaminal approach  
14 with the same type of apparatus may alternatively be used. The blunt or rounded  
15 distal tip of apparatus 20 optionally may be somewhat sharper, to facilitate placement.  
16 The apparatus 20 may be preceded by a guidewire, a dilator, or a needle introducer  
17 (possibly with or followed by an expandable sheath).

18 [0337] This variation of the apparatus and method, as seen in FIG. 40b, contains a  
19 rigid, curved wire or needle 22, which may be steerable, which is driven from the tip  
20 of the apparatus 20, laterally through the neural foramen and then posteriorly, around  
21 the facet joint complex 12 and back towards apparatus 20, where the needle may be  
22 received once again by the apparatus. Curved guide wire 22 can be advanced through  
23 the probe such that it passes transforaminally and reengages probe 20 after completely  
24 encircling facet 12. As discussed previously, guide wire 22 may be configured to  
25 stimulate and monitor the response of the nerve root during transforaminal passage to

1 ensure proper positioning of the wire. As seen in FIG. 40d, probe 200 then is  
2 withdrawn from the patient, leaving guide wire 22 in position transforaminally to  
3 provide access.

4 [0338] FIG. 41 provides a cross section through apparatus 20 that illustrates an  
5 exemplary geometry for the apparatus comprising a feature that facilitates receiving  
6 of the distal end of the needle or rigid guidewire back within the apparatus.

7 Alternative geometries will be apparent. Once received back within apparatus 20, the  
8 wire 22 completely encircles the facet joint 12, as in FIG. 40c, d. In FIGS. 41, and  
9 42, guidewire 22 has been replaced by tissue abrasion device 30, e.g., a belt, strap or  
10 ribbon, preferably within a protective sheath or cover 32, with the abrasive surface of  
11 the device in contact with the anterior-medial facet complex. Apparatus 20 is pulled  
12 back, bringing the working surface (exposed abrasive portion) of the instrument into  
13 firm contact with operator controlled pressure against the surface from which tissue  
14 removal will occur. Neuroforaminal enlargement begins with the movement of the  
15 abrasive surface 30 against the anterior and medial portion of the facet complex, in  
16 the lateral recess and neural foramen.

17 [0339] With reference to FIG. 41, an enlarged view of the mechanical portion of  
18 apparatus 20 is described. An abrasive surface 30 is disposed along the inside side of  
19 tissue abrasion element. The abrasion device may be actuated, e.g., via rotation of a  
20 gear 106 within the apparatus 20. Debris may be captured within apparatus 20, and  
21 stored in the shaft and/or handle, or removed continuously during the procedure. In  
22 some variations, tissue removal surface 30 of device 20 comprises one or more  
23 powered mechanical tissue removal elements. The powered mechanical tissue  
24 removal elements may comprise, for example, band saws, belt shavers, rotary burrs or  
25 blades, reciprocating burrs or blades, etc. FIG. 41 illustrates a rotary variation of the



1 tissue removal device that may be powered or operated manually, and that may  
2 remove tissue in a single direction, or in a reciprocating fashion. In FIG. 41, tissue  
3 removal device 20 comprises a belt coupled to drive wheel 106. The drive wheel may  
4 be rotated by hand or via a motor in either direction to advance or retract device 20  
5 relative to neural protection element 32 and window in order to selectively remove  
6 tissue.

7 **[0340]** Irrigation optionally may be provided through element 20 via irrigation lumen  
8 324 of member 20. Suction optionally may be provided through element 20 via  
9 suction lumen 326 of member 20. Suction and/or irrigation may be provided  
10 intermittently or continuously, as desired by the medical practitioner.

11 **[0341]** Referring now to FIG. 42, a variation of the apparatus of FIG. 41 is described  
12 comprising an additional protective cover 32 that covers one or more sides of the  
13 abrasive elements 14 of the device 20 in all regions except for the area covering the  
14 tissue where abrasion is to take place. This cover may contain a conductive element  
15 in order to enable nerve stimulation and/or to facilitate neural localization. Nerve  
16 stimulation capabilities may be present on the internal abrasive surface 30 of device  
17 abrasive element, and/or on the external side (non-tissue abrading) of the device, as an  
18 added safety measure. For example, the user may send an electric impulse through a  
19 conductive element within the back-side (external surface) of the device, expecting to  
20 achieve neural stimulation when the device is in place through the neural foramina,  
21 while neural stimulation should not be achievable with a similar electrical impulse  
22 conducted across a portion of the abrasive side of the device. In this manner,  
23 information from monitoring the nerve stimulation may ensure proper placement of  
24 the abrasion device and reduce a risk of inadvertent neural or perineural vascular  
25 abrasion.

1 [0342] In FIG. 43, straight wire or needle 4 is driven through curved needle 16  
2 disposed in working channel 50 of double barrel epidural needle. This straight wire  
3 or needle 4 is advanced until it has penetrated through the skin and out of the patient's  
4 body. The straight wire preferably has a sharp tip. In FIG. 44, curved needle 16 is  
5 withdrawn from working channel 50, leaving straight wire or needle 4 in place. Then,  
6 as seen in FIG. 45, the epidural needle and working channel may be withdrawn from  
7 the patient, or, in an alternative embodiment (FIG. 15b), when using a detachable  
8 working channel 50, the working channel alone may be withdrawn from the patient,  
9 leaving straight wire 4 in place. In FIG. 46, straight wire 4 is hooked to abrasion  
10 device 14 and/or the abrasion device's protective sleeve 6. In FIG. 47, the abrasion  
11 device 14 and/or the device's protective sleeve are pulled into position by wire 4 as  
12 the wire is removed. In FIG. 48, wire 4 has been completely removed, and the  
13 abrasion device 14 and its protective sleeve 6 are properly positioned for tissue  
14 resection, anterior to the facet 12 and ligamentum flavum 10.

15 [0343] In an open surgical variation, the abrasive element 14 and its cover 6 may be  
16 placed through the surgical incision, from a interlaminar, translaminar, or  
17 neuroforaminal approach. Visualization and placement may be aided via partial or  
18 complete laminectomy, facetectomy, or ligamentectomy. Methods for threading the  
19 neural foramina include, but are not limited to the use of a wire, blunt needle, probe,  
20 endoscope, or suture. After spinal neuroforaminal placement, the abrasion device 14  
21 is used to selectively remove tissues that impinge on the neurovascular structures  
22 within the lateral recess 108 and neural foramen 110, on the anterior side of the facet  
23 joint 12. In an open approach, as with a percutaneous approach, the device may be  
24 inserted through a needle, optionally under image guidance or with the aid of an  
25 epidural endoscope. Once placed through the neural foramina 110 of the spine,



1 around the anterior border of the facet joint 12, and anterior to the ligamentum flavum  
2 10, the medical practitioner may enlarge the lateral recess and neural foramina via  
3 frictional abrasion, i.e., by sliding the abrasive surface across the tissue to be resected  
4 (e.g., far lateral ligamentum flavum, anterior and medial facet, osteophytes). The  
5 abrasion device alternatively or additionally may be placed through the neural  
6 foramen 110 anterior to the facet joint 12, but through or posterior to the ligamentum  
7 flavum 10. The medical practitioner controls the force and speed of the abrasive  
8 surface against the tissue to be removed, while optional protective covers, tubes or  
9 sleeves 6 help limit the area exposed to the abrasive element for treatment.

10 [0344] Referring now to FIGS. 49-64, a variation of the method and apparatus of  
11 FIGS. 43-48 is described, comprising another preferred approach for placement of the  
12 abrasion device. This series begins with FIG. 49, in which a double lumen, blunt  
13 tipped, epidural device 84, has already been advanced to the lateral recess 108, using  
14 a technique similar to FIG. 19. Next, FIG. 50 shows a curved flexible needle 16,  
15 preferably with an atraumatic tip, that has been advanced, via the working channel 50  
16 (FIG. 16), through the neural foramina 110. FIG. 51 illustrates threading of the  
17 straight, flexible, sharp tipped wire 4a through the curved needle 22, and advanced  
18 posteriorly until it exits the skin of the back. In FIG. 52, the curved needle has been  
19 withdrawn, leaving the straight wire 4a in place. In FIG. 53, the double lumen  
20 epidural apparatus 84 is slightly withdrawn, from the patient, so that the working  
21 channel 50 is directed towards the medial side of the face complex. FIG. 54 shows  
22 the curved needle 16 advanced through the working channel again, adjacent to the  
23 first wire 4a, this time advancing the same or a different curved, flexible needle 16,  
24 towards the opposite side of the facet complex 12. FIG. 55 shows where a second  
25 straight flexible wire 4b is advanced through the second placement of a curved needle

1 16, this time on the medial side of the facet joint. The second sharp, flexible, straight  
2 wire 4b is threaded through this second curved needle, and subsequently advanced  
3 posteriorly, until the sharp tip of the wire 4b exits the skin 70. FIG. 56 next shows  
4 both the curved needles and the double lumen apparatus removed, leaving the wires  
5 4a and 4b in place.

6 [0345] FIG. 57 shows that both wires have been attached to the two ends of the  
7 abrasive element 14 and/or the cover 6 of the abrasive element. With access  
8 established, via either a percutaneous or an open approach (or a combination thereof),  
9 neural protection and/or tissue removal elements may be introduced via the access for  
10 safe, selective removal of tissue. It should be understood that the methods and  
11 apparatus described hereinafter are equally applicable to both open and percutaneous  
12 approaches. For the purpose of clarity, they may be illustrated utilizing only a  
13 percutaneous or open access, but this should in no way be construed as limiting.

14 [0346] In order to reduce a risk of neurological damage during selective tissue  
15 removal, variations of the present invention optionally may provide neural protection  
16 during tissue removal. In one variation, a neural protection element, such as a sheath,  
17 shield or backstop, is positioned such that the neural protection element separates  
18 impinging tissue in the neural foramen from the underlying nerve root. Tissue  
19 removal then may proceed by advancing a tissue removal device into position  
20 between the foramen and the neural protection element. When access to the stenosed  
21 region is via an open surgical procedure, it may be possible for the medical  
22 practitioner to manually place the neural protection element. Alternatively, when  
23 using either an open or a percutaneous access, the neural protection element may be  
24 advanced over, or pulled into place by, an access guide wire placed as described  
25 previously.



1 [0347] Alternatively, the two wires 4a and 4b may be opposite ends of the same  
2 continuous wire, with the cover 6 for the abrasive element 14 already placed over the  
3 mid-portion of the wire 4. Alternatively, the abrasive element 14 may already have  
4 been placed inside said cover 6, and attached at each end to the wires 4a and 4b.  
5 FIGS. 58 and 59 show the two wires 4a and 4b pulled and bringing the abrasive  
6 element cover, possibly with the abrasive element 14 already placed inside said cover  
7 6, into position through the neural foramina. FIG. 60 illustrates the step that follows  
8 placement of the abrasion element cover 6 alone. In FIG. 60, with the wire 4 in place  
9 inside the abrasion element cover 6, the abrasive element 14 is now seen to have been  
10 attached to the end of the wire. Subsequently, the cover 6 is held open at each end by  
11 a grasping device, which also holds the cover 6 under tension against the tissue to be  
12 abraded. With the cover anchored thus, the abrasive element 14 is pulled into place  
13 by the wire 4a/b, replacing the wire, as has occurred for FIGS. 61 and 62. With the  
14 abrasive element in position and the abrasive element cover 6 tightly held open and  
15 against the tissue to be abraded, the abrasion element 14 may be pulled back and  
16 forth, under tension, against the tissue to be abraded, as in FIG. 62. Alternatively, the  
17 abrasive element may be pulled in a single direction across the tissue to be abraded.  
18 FIG. 63 illustrates the cover 6 following removal of the abrasive element. Said cover  
19 may remain in place as a compression bandage, under tension against the freshly  
20 abraded surface, in order to promote hemostasis, promote tissue remodeling, and trap  
21 debris post operatively.

22 [0348] A nerve stimulator may be incorporated into the abrasive surface of the  
23 abrasive element, and/or incorporated into the protective cover or sheath for the  
24 abrasive element, in order to verify correct placement and enhance safety by allowing  
25 the medical practitioner to ensure that neural tissue is not subject to inadvertent

1 abrasion. FIG. 64 illustrates a neural stimulation apparatus. FIG. 64 also illustrates  
2 an abrasion element 14, disposed inside of a sheath or cover 6, and held in place by  
3 tension retaining elements 112.

4 [0349] The stimulation apparatus 114 delivers a small electrical current through the  
5 working surface and/or the non-working surface (backside) of either the tools used in  
6 the epidural space, the abrasive element 14, and/or the protective cover 6 of the  
7 abrasive element. Preferably, one electrode 120 would be connected to each side  
8 (abrasive and non-abrasive) of the entire device and sheath complex, along the full  
9 distance where tissue abrasion is planned to occur, in the lateral recess, central canal,  
10 or neural foramen. Neural stimulation may be monitored via verbal response to  
11 stimulation in an awake or lightly sedated patient, or SSEP, MEP, EMG, or motor  
12 evoked muscular movement in an asleep or sedated patient. One possible mechanism  
13 for avoiding inadvertent neural damage may be to ensure that there is no neural  
14 stimulation when stimulating the working surface of the device. A positive control  
15 should be obtainable in the lateral recess and neural foramen, when stimulating the  
16 non working surface (back side) of the device or, preferably, the backside of the  
17 device cover or sheath 6 (e.g., first portion of locking mechanism).

18 [0350] After the abrasion element, and possibly its protective sheath or cover 6, have  
19 been placed through the neural foramina 110 the abrasive surface is brought into firm  
20 contact with the tissue to be abraded by pulling tension simultaneously on each end of  
21 the abrasion element. When both ends of the abrasive element 14 are pulled  
22 simultaneously, the abrasive surface of the device is brought under tension and into  
23 firm contact with the impinging spinal tissue on the anterior and medial sides of the  
24 facet joint complex. Subsequently, one end of the abrasive element is pulled more  
25 forcefully than the other, sliding the abrasive surface is across the target tissue. When



1 one end of the abrasive element is pulled with more force than the other, the ribbon  
2 moves in the direction of the stronger pull, while the lesser pull on the opposite end  
3 maintains force and creates friction with movement between the abrasive surface and  
4 the tissue to be resected. When the optional protective cover 6 or sheath is provided,  
5 both of its ends of the are, in one variation, pulled under traction and anchored in  
6 place, such that the abrasive element 14 may be pulled in either or both directions  
7 through the cover 6 or sheath without significant friction against and/or without  
8 causing trauma to adjacent tissues.

9 **[0351]** Alternatively, the abrasive element 14 may be pulled in a single direction  
10 across the tissue. The abrasive belt, strap or ribbon may be a single length, pulled  
11 alternately in each direction, or it may be dispensed from a spool, as in FIG. 65a, or  
12 from a reel to reel configuration, as in FIG. 65b, and pulled in both directions or  
13 pulled in a single direction, across the tissue to be abraded. An alternative variation  
14 of the apparatus and method utilizes an electromechanical, belt driven abrasive tool,  
15 an example of which was described previously in FIGS. 41 and 42.

16 **[0352]** In one variation of the invention, a tissue retention or compression dressing  
17 (FIGS 63, 73, 75) method and apparatus are utilized immediately after the tissue  
18 removal, ablation and remodeling procedures described above. For example,  
19 following neuroforaminal and lateral recess enlargement, it may be advantageous to  
20 leave, as a surgical dressing, a thin flat element 150 pulled tightly against the resected,  
21 abraded, or remodeled tissue surface (e.g., around the facet complex). It is expected  
22 that a compression dressing of this nature will enhance hemostasis, promote healing  
23 and promote subsequent tissue remodeling with the neural foramen widely open.  
24 Also, the surgical dressing 150 would provide a barrier to trap tissue debris away  
25 from neural or neurovascular structures, while providing an optional technique for

1 delivering medication, possibly as a depot, to the operative site. The dressing 150  
2 would also present a smooth surface towards the nerve root in the immediate post-  
3 operative period.

4 **[0353]** As in FIG. 63, this neuroforaminal compression dressing may be  
5 percutaneously held tightly in place against the resected, abraded, or otherwise  
6 remodeled surface (e.g., zygapophysial (facet) joint) 12. In certain embodiments, the  
7 compression dressing may be either percutaneously removable (as shown in FIGS. 63  
8 and 73), either by pulling the dressing through the neural foramen, or by the inclusion  
9 of a biodegradable central component of the dressing, such that the two ends may be  
10 removed, with the dressing separating at its biodegradable portion in the middle. In  
11 other variations, a compression dressing may include a totally implanted and  
12 completely biodegradable dressing, as illustrated in FIGS. 75a or b.

13 **[0354]** FIGS. 49-59 and 63, and FIGS. 66-73 illustrate midline or paramedian  
14 approaches to percutaneous placement of a neuroforaminal compression device (e.g.,  
15 percutaneous retention compression dressing or tissue remodeling strap) 150 that is  
16 wrapped around the facet complex and retracts the posterior aspect of the neural  
17 foramina, effectively dilating the space available for the neural and vascular  
18 structures. FIGS. 74 a and b illustrate the first steps in a posterior lateral  
19 neuroforaminal approach to placement of a compression element (subsequent steps  
20 would share similarities with the approach illustrated in FIGS. 49-59 and 63). A  
21 grasper, loop or hook 146 can be for grabbing an end of the guidewire.

22 **[0355]** An additional embodiment of the method and apparatus may combine both the  
23 working backstop 134 and the compression element 150, as illustrated in FIGS. 76  
24 and 77. In these illustrations, the compression element 150 serves to keep the  
25 working barrier 134 in proper position. Subsequently, image guidance may be used to



1 guide tools used in open or percutaneous procedural approaches to neuroforaminal  
2 and lateral recess enlargement. The example in FIG. 77 illustrates an image guided  
3 drill 176 removing a portion of the impinging facet complex. With the barrier in  
4 place, possibly further aided by neural stimulation/localization capabilities, selective  
5 and safe tissue removal may be more readily performed.

6 [0356] FIGS. 78-81 illustrate some of the compression element embodiments 150.  
7 FIG. 79 also contains an area (e.g., a drug depot in a retention strap or compression  
8 dressing) 162 for storage of medications for delivery to the tissue retracted by the  
9 compression element 150. The compression element can have a locking mechanism  
10 that can have a first portion 172 that can insert through a second portion, and can have  
11 a locking mechanism that can have a second portion 174 that can receive a first  
12 portion 172.

13 [0357] FIGS. 82 and 83 demonstrate additional methods and apparatus for  
14 enlargement of the central spinal canal and lateral recess, by retracting the posterior  
15 spinal anatomy, in particular the ligamentum flavum 10 (FIGS. 79 and 80 illustrate  
16 translaminar ligamentum flavum retraction), in a further posterior direction, away  
17 from the dura 46, cauda equina 140, nerve roots 62, and dorsal root ganglia. Such a  
18 device would both serve both to retract the spinal tissue posteriorly, and to prevent the  
19 posterior elements, particularly the ligamentum flavum 10, from buckling anteriorly  
20 into the spinal canal or lateral recess. FIG. 82 illustrates an apparatus with an anchor  
21 126 anterior to or within the ligamentum flavum, a second (e.g., laminar) anchor  
22 posterior to the lamina 124 (e.g., for posterior retention) and a mechanism for  
23 maintaining tension in order to retract the tissues posteriorly, towards the lamina 22.  
24 FIG. 83 illustrates a rivet type device that is placed through a hole that has been  
25 drilled through the lamina 124. Such a rivet has an anchor 126 placed anterior to the

1 ligamentum flavum 10, which is retracted posteriorly in order to enlarge the central  
2 spinal canal and/or lateral recess. Spinal endoscopy may be used as a tool to place a  
3 ligamentum flavum retraction system, or in order to confirm that correct placement  
4 and efficacy has been achieved.

5 [0358] Most of the safety issues related to the methods and apparatus described herein  
6 are similar to those associated with any surgical procedure, e.g., infection and/or  
7 bleeding. Some safety issues are more specific to surgery in and around the spine or  
8 spinal cord, and are therefore given special consideration below. These generally  
9 relate to spinal nerve injury. Morbidity could result from instruments inadvertently  
10 passed through the dura mater, and creating a cerebrospinal fluid leak and/or  
11 damaging the cauda equina (caudal to T12-L1) or spinal cord (cephalad to T12-L1)  
12 when entering the epidural space. Potentially traumatized structures further include  
13 nerve roots, adjacent vasculature, or dorsal root ganglia.

14 [0359] FIGS. 84 are sagittal midline cryosections of the lumbar spine (provided  
15 courtesy of Wolfgang Rauchning, MD) that demonstrate the ligamentum flavum  
16 protruding (“buckling”) anteriorly, a potential mechanism for central or lateral recess  
17 neural or neurovascular impingement. The ligamentum flavum is a potential target  
18 for tissue resection using the herein described methods and apparatus.

19 [0360] FIGS. 85, 86, 87, 88, 90 illustrate preferred embodiments of the protective  
20 cover or sheath for the abrasion element, in which the abrasive surface is covered 94  
21 and the backside of the abrasive element may also be shielded 96, to prevent tissue  
22 damage in areas where tissue abrasion is not intended. The abrasive element’s  
23 protective cover is ideally shaped to provide optimal protection of vulnerable tissues,  
24 at the same time maintaining both a very small profile, for easy threading of the  
25 stenotic neural foramen; and atraumatic edges (e.g. rounded), in order to prevent



1 cutting of or trauma to neural, vascular or other tissue during placement, use or  
2 removal of the device. For example, in certain preferred embodiments, the abrasion  
3 device may be tubular, with an opening over the tissue to be abraded; or may be flat  
4 (FIGS. 86, 87, 88, 90) with atraumatic railings or tracks that facilitate passage of the  
5 abrasion element, abrasion surface cover, or other instruments. Side channels,  
6 through which the edges of the abrasion element may be maintained but are able to  
7 slide freely may be of an atraumatic shape 82. Said side channels may also hold the  
8 protective cover 94 for the abrasive side of the abrasion element 14. Note that neural  
9 stimulation and localization may be performed through a conductive element in the  
10 back cover 96, the front cover 94, or in the abrasive side of the abrasive element itself  
11 14. Both free ends of the device, as well as the ends of the optional protective sheath  
12 or cover 6, are positioned external to the patient for manipulation by a medical  
13 practitioner.

14 [0361] FIGS. 87 show a similar protective cover and abrasive element configuration  
15 to that described in FIGS. 86, this time with neural stimulation element 92 only  
16 illustrated in the non-abrasive side of protective cover. In addition, FIGS. 87e and 87f  
17 show that the abrasive element 14 has been replaced by an alternative element for  
18 drug deposition 88, and/or to serve as part of the compression dressing, when the  
19 elements are left under tension against the abraded surface, after the operative  
20 procedure.

21 [0362] FIGS. 88 illustrate an additional similar embodiment of the abrasive element  
22 14 with protective covers 94 and 96. This time, no neural stimulation elements are  
23 illustrated.

24 [0363] Referring now to FIGS. 89 and 90, sections through the abrasive apparatus are  
25 illustrated. The abrasive element 14 is seen, housed within the protective covers. In

1 some variations of neural protection element 6 and tissue removal device, the neural  
2 protection element 6 and the tissue removal device 14 may comprise mating features  
3 to facilitate advancement of the device through the element. In FIG. 89, element 14  
4 comprises track 220 that mates with protrusions 330 of device. In the variation of  
5 FIGS. 89 and 90, neural protection element 6 also comprises recessed space 230  
6 disposed between device 14 and the backside of the element. Tissue or debris  
7 removal or capture may be accomplished through this space. For example, when  
8 tissue removal elements comprise features punched, stamped, cut, etched, etc. through  
9 device 14, removed tissue may fall through the punched features and collect within  
10 space 230. This space optionally may be emptied of debris during a procedure via  
11 irrigation and/or aspiration, but alternatively may be used as a reservoir where debris  
12 may collect for removal at the conclusion of a procedure.

13 [0364] As shown, the abrasion element may, for example, be structured as a thin belt  
14 or ribbon 14, with an abrasive and/or cutting surface on one of its sides. The abrasive  
15 element 14 may exist in a variety of shapes, ranging from flat to curved; from narrow  
16 to wide; and from a solid to perforated. The abrasive surface of the abrasive element  
17 14 may, in one variation, contain deep grooves 118 or perforations for the transport of  
18 debris away from the operative site. Alternatively, the pattern of abrasive may be  
19 designed to control the direction and speed of movement of the surface across the  
20 tissue to be abraded (e.g. deep grooves, at a diagonal to the edge of the straps, may be  
21 used to facilitate lateral movement of the abrasive element). The width and shape of  
22 the abrasive elements may also be varied, in further effort to control the area of tissue  
23 to be resected. Finally, in one preferred variation, the surgeon would begin with a  
24 coarser grade of abrasive material, in order to gain more aggressive tissue removal.  
25 Sequential use of less and less aggressive surfaces would serve to smooth the abraded



1 tissue surface, with the aim of creating an atraumatic surface for contact with  
2 neurovascular structures.

3 **[0365]** Placement of a tissue abrasion device 14 through protective sleeve(s) 6 and  
4 into position for selective tissue removal, brings the abrasive surface 14 into contact  
5 with the tissue to be removed. A medical practitioner may remove tissue in contact  
6 with abrasive surface (FIGS. 90a, b, c) by applying a reciprocating or unidirectional  
7 motion to the ends of device 14 exterior to the patient. In one variation, a spool or  
8 reel to reel configuration may be designed that begins with a coarse grade of abrasive  
9 material, and progresses towards less abrasive materials as the spool or reel unwinds.

10 **[0366]** FIGS. 90a-90c illustrate additional mechanical variations of tissue removal  
11 elements. FIGS. 90a and 90b illustrate alternative blade or saw configurations. The  
12 blades may comprise various shapes, sizes and configurations, as desired.

13 Furthermore, the blades may be attached to the tissue removal device or may be  
14 formed by punching or stamping through the device with optional subsequent  
15 grinding of the punched edge. Alternatively, the blades may be formed by a chemical  
16 etching process. The blades may comprise a 3-dimensional profile to facilitate  
17 cutting, for example, a bow or a corrugation or a 'cheese grater' profile. Furthermore,  
18 the blades may be placed at one or more angles relative to the direction of tissue  
19 removal. Cutting surfaces of the blades may be oriented in a single direction or may  
20 be oriented in multiple directions. Additionally, the blades may be serrated. As  
21 another alternative, the mechanical elements may comprise fine cutting wires or a  
22 Gigli saw. A plurality of cutting wires or Gigli saws may be joined or woven together  
23 or flattened to form a substantially planar cutting surface. FIG. 90c illustrates an  
24 abrasive or rasp variation of element 14.

1 [0367] With reference to FIGS. 91, neural protection element 6 and tissue removal  
2 device 14 are described in greater detail. As seen in FIG. 91A, window 204 of sheath  
3 6 of neural protection element is disposed on the posterior-facing or working side of  
4 the sheath. In some variations, edge 205 of window 200 is sharpened to coact with  
5 tissue removal device 14. This may be especially useful when the tissue removal  
6 device removes tissue with a blade. In another variation, edge 205 or a portion  
7 thereof may be energized, for example, to provide a negative control for neural  
8 localization, to ablate or denature impinging tissue and/or to achieve hemostasis. In  
9 still further variations, edge 205 is both sharpened and configured to be energized.

10 [0368] Window 204 limits exposure of tissue removal surface of tissue removal  
11 device 14 only to the localized region of the patient's tissue where selective tissue  
12 removal is desired. As seen in the cross-sectional view of FIG. 91D, neural protection  
13 element 14 may completely surround tissue removal device 6 in areas other than  
14 window 204. However, as seen in the cross-section of FIG. 91E, tissue removal  
15 surface 302 is exposed within the window. Window 204 may be positioned such that  
16 it directly underlies and faces the neural foramen and impinging tissue, as in FIGS.  
17 61-64. Irrigation and/or aspiration optionally may be provided through the window  
18 204, e.g., for debris removal. Suction also may be drawn through the window to  
19 engage impinging tissue and/or to provide a seal against the tissue. In some variations  
20 of neural protection element 6, the window optionally may be opened, closed or re-  
21 sized by a medical practitioner as desired. For example, the window may be closed  
22 during delivery, opened during selective removal of impinging tissue, then closed  
23 during retrieval of the sheath.

24 [0369] Neural protection element 6 preferably comprises an atraumatic profile to  
25 reduce tissue injury during placement and retrieval. For example, the element may



1 comprise rounded edges 82, as seen in FIGS. 91D and 91E. The device preferably  
2 comprises a low profile having a width that is larger than its height. The width may  
3 be any desired width; for example, when used within the neural foramen, width may  
4 be up to the distance between adjacent pedicles within the foramen. In one variation,  
5 a width of less than about 7 mm may be provided. The height preferably provides for  
6 safe placement of element between impinging tissue and nerve root 62. In one  
7 variation, a height of less than about 2 mm may be provided. In one variation,  
8 element has a length sufficient to allow for transforaminal passage of the element, as  
9 well as positioning of ends of the element outside of the patient.

10 [0370] As seen in FIG. 91B, tissue removal device 14 comprises tissue removal  
11 surface 302 having tissue removal elements. Tissue removal elements may be chosen,  
12 for example, from a wide variety of abrasive elements, cutting elements, electrical  
13 ablation elements, or combinations thereof. In FIGS. 91, tissue removal elements  
14 illustratively comprise sharpened blade edges 118 for cutting through tissue and/or  
15 bone. Edges 118 may be formed, for example, by punching through tissue removal  
16 device 14 and optionally sharpening the edges of the punch, for example, via a  
17 grinding process.

18 [0371] As seen in FIG. 91C, tissue removal device may be positioned within neural  
19 protection element 6 such that tissue removal elements on tissue removal surface 302  
20 are locally exposed within window 204 of element. Edge 205 of window 204 may be  
21 sharpened to provide for guillotine-type cutting between sharpened edges 100 of the  
22 tissue removal device and edge 205 of the window. This may provide enhanced shear  
23 forces that may be well adapted to cutting of soft tissue.

24 [0372] With reference again to FIGS. 61-64 in conjunction with FIGS. 91, after spinal  
25 neuroforaminal placement, tissue removal elements 302 of device may be used to

1 selectively remove tissues that impinge on the neurovascular structures within the  
2 lateral recess and neural foramen, anterior to the facet joint, thereby enlarging the  
3 lateral recess and neural foramina via selective tissue removal. Impinging tissue to be  
4 targeted for removal may include, but is not limited to, lateral Ligamentum Flavum,  
5 anterior and medial facet, and osteophytes. Tissue removal may be achieved in a  
6 variety of ways.

7 [0373] FIGS. 92 illustrate additional variations of mechanical tissue removal  
8 elements. In FIG. 92A, tissue removal elements 304 comprise coacting blades 340  
9 and 342 that may be drawn across tissue to achieve a scissor-type cutting action.  
10 Edge 205 of window 204 of element 200 may be sharpened to contribute to tissue  
11 cutting. In FIG. 92B, a series of blades 344 and 346 cross and are sharpened on both  
12 sides for bidirectional or reciprocating scissor-type cutting. FIG. 92C illustrates v-  
13 shaped blade or a scissor-type cutting variation wherein the blades are formed through  
14 device coacting with sharp window edge. FIG. 92D illustrates a diamond cutting  
15 pattern for tissue removal surface 302. FIG. 92E illustrates a more densely packed  
16 diamond cutting pattern. FIG. 92F illustrates a variation wherein the cutting surfaces  
17 are angled along a common orientation. FIG. 92G illustrates a variation comprising  
18 punched tissue removal elements and scalloped or cut-out edges of device 300, which  
19 edges optionally may be sharpened. FIG. 92H illustrates a scissor-type cutting  
20 variation with scalloped or cut-out edges. Additional mechanical tissue removal  
21 elements will be apparent.

22 [0374] In another variation of tissue removal device, tissue removal elements 304  
23 comprises one or more electrosurgery elements for tissue removal/ablation. The  
24 electrosurgery elements additionally or alternatively may be utilized to achieve  
25 hemostasis and/or to facilitate neural localization. Monopolar or bipolar RF elements



1 may, for example, be utilized and may be activated with a thermal or substantially  
2 non-thermal waveform.

3 [0375] FIGS. 93 illustrate an electrosurgical variation comprising a plurality of wire  
4 loop electrodes 350 that serve as tissue removal elements 304. Wire loop electrodes  
5 350 are located on tissue removal surface 302 of device 300. Device 300 may, for  
6 example, comprise an electric textile or a flexible printed circuit board having wire  
7 loop electrodes 350. The electrodes may be brought into contact with impinging  
8 tissue, then actuated to remove, singe, denature, or otherwise remodel the tissue.  
9 Optionally, tissue that has been treated electrosurgically may be scraped away after  
10 electrosurgical treatment in order to remove the tissue. Advantageously, in the  
11 variation of FIGS. 93, device 300 optionally may remain stationary during tissue  
12 removal. The device optionally may be integrated with neural protection element 200  
13 such that the wire loop electrodes are formed on the working side of the protection  
14 element. In FIG. 93C, device 300 is shown disposed within neural protection element  
15 200, such that wire loop electrodes 350 are positioned within window 204.

16 [0376] FIG. 94 illustrates an electrosurgical variation comprising bipolar electrode  
17 pair 360 that serve as tissue removal elements 304 disposed on tissue removal surface  
18 302 of device 300. Device 300 may, for example, comprise an electric textile or a  
19 flexible printed circuit board having electrode pair 360. The electrodes may be  
20 brought into contact with impinging tissue, then actuated to remove the tissue.  
21 Advantageously, in the variation of FIG. 94, device 300 optionally may remain  
22 stationary during tissue removal. The device optionally may be integrated with neural  
23 protection element 200 such that the bipolar electrode pair is formed on the working  
24 side of the protection element. For example, a bipolar electrode pair may be formed

1 across window 204, and the impinging tissue optionally may be drawn within the  
2 window via suction or some other means prior to electrosurgical removal.

3 [0377] FIG. 95 illustrates another electrosurgery variation of device 300 wherein  
4 tissue removal surface 302 comprises a plurality of electrosurgery tissue removal  
5 elements 370, illustratively bipolar electrode pairs. The bipolar electrodes may be  
6 actuated or energized, either concurrently or in any desired sequence, while surface  
7 302 of device 300 is drawn across impinging tissue to remove the tissue.

8 [0378] FIG. 96 illustrates a combined mechanical and electrosurgical tissue removal  
9 device 300. Tissue removal surface 302 comprises mechanical tissue removal  
10 elements 380, illustratively stamped or raised shaver blades, interspersed with  
11 electrosurgery tissue removal elements 370, illustratively bipolar electrode pairs.

12 [0379] FIG. 97 illustrates an exemplary method of using an electrosurgery variation  
13 of the tissue removal device. In FIG. 97, neural protection element 200 is delivered,  
14 illustratively via previously described access element 180. In this variation, element  
15 200 illustratively comprises a local backstop that does not extend out of the patient.  
16 Tissue removal device 300 is positioned between element 200 and the impinging  
17 tissue, and optionally may be anchored via temporary tissue anchor 390 to provide  
18 leverage for pulling the device into contact with the impinging tissue. Electrosurgery  
19 tissue removal elements 304 then may be actuated to remove the impinging tissue  
20 and/or provide hemostasis, etc. Although element 200 and device 300 illustratively  
21 do not extend out of the patient in the electrosurgery variation of FIG. 97, it should be  
22 understood that in other electrosurgery variations the elements may extend outward  
23 through the patient's skin as described previously.

24 [0380] Referring now to FIGS. 98, another variation of tissue removal device 300 is  
25 described. As seen in FIG. 98A, tissue removal device 300 may comprise flexible



1 support 400 that may be positioned, for example, through or along neural protection  
2 element 200, or may be integrated with the neural protection element. As seen in  
3 FIG. 98B, at least a portion of support 400 comprises wire saw 410 that is coupled to  
4 the support and serves as tissue removal element 304 disposed on the working surface  
5 of device 300. The wire saw may be drawn or reciprocated across impinging tissue,  
6 such that saw 410 locally removes tissue. Since support 400 is wider than wire saw  
7 410, the support limits a depth of cutting via wire saw 410.

8 [0381] The medical practitioner may move support 400 laterally while drawing or  
9 reciprocating the wire saw across tissue in order to enlarge a width of the region in  
10 which tissue is removed. Support 400 may limit a depth of cutting during such lateral  
11 expansion of the cut area. When the lateral expansion exceeds the width of support  
12 400, cutting to greater depth may be performed as desired. The width of the area of  
13 tissue removal alternatively or additionally may be enlarged or expanded by utilizing  
14 multiple wire saws 410, as seen in FIG. 98C. The multiple saws may be advanced  
15 initially, or may be advanced after creation of an initial cut with a single saw such as  
16 that of FIG. 98B. Additional methods of using the variation of FIGS. 98 for selective  
17 removal of tissue will be apparent.

18 [0382] With reference to FIGS. 99, a variation of the tissue removal device of FIGS.  
19 98 is described. As seen in FIGS. 99, support 400 may comprise fenestrations 402  
20 that facilitate passage of removed tissue through the fenestration for removal. FIG.  
21 99A illustrates a segment of support 400 without wire saw(s) 410, while FIG. 99B  
22 illustrates a segment with the wire saw. Wire saw(s) 410 may be coupled to the  
23 support or optionally may be advanced into position along the support, then  
24 reciprocated or moved in conjunction with the support, such that the support limits a  
25 depth of cutting via the saw(s). When tissue removal device 300 having fenestrated



1 support 400 is disposed within neural protection element 200, fenestrations 402 may  
2 facilitate passage of removed tissue or other debris through the fenestrations, such that  
3 they are captured within the neural protection element between the neural protection  
4 element and the tissue removal device for removal from the patient.

5 **[0383]** Referring to FIGS. 100, another variation of tissue removal device 300 is  
6 shown. In FIGS. 100, tissue removal device 300 is integrated within neural protection  
7 element 200. The tissue removal device comprises tissue removal elements 304  
8 having blades 420, illustratively cup blades with sharpened edges. Blades 420 are  
9 coupled to drive shafts 422 that rotate the blades (either individually or in unison) at  
10 high speed for tissue removal. Drive shafts 422 may be utilized (either individually or  
11 in unison) to advance and/or retract rotating blades 420 across window 204 of neural  
12 protection element 200 for removal of tissue. Although device 300 illustrative  
13 comprises a plurality of blades 420 and drive shafts 422, it should be understood that  
14 the device alternatively may comprise a single blade and drive shaft, or a single drive  
15 shaft for rotating multiple blades

16 **[0384]** Any other tissue removal elements 304 may be utilized with any of the  
17 variations of tissue removal device 300, including, but not limited to, lasers, which  
18 may comprise one or more optical fibers for delivering a laser beam, high-pressure  
19 fluids, thermal elements, radioactive elements, etc. It should be understood that  
20 various tissue removal elements may be used in any combination, as desired.

21 **[0385]** In one variation, device 300 may be reciprocated, either manually or under  
22 power, to cut, abrade or otherwise remove tissue. FIG. 101 illustrates a variation of  
23 tissue removal device 300 well-suited for manual reciprocation. In FIG. 101, device  
24 300 illustratively comprises handles 308, one or both of which may be detachable for  
25 placement and/or retrieval of the device. The medical practitioner may grasp the

1 handles and reciprocate device 300 to selective remove tissue impinging on window  
2 204 of neural protection element 200.

3 [0386] In another variation, device 300 may be pulled in a single direction, either  
4 manually or under power, to remove tissue. FIG. 102 illustrates a variation of device  
5 300 well-suited for unidirectional tissue removal, either manual or powered. In FIG.  
6 102, device 300 comprises a reel-to-reel configuration. Tissue removal elements 304  
7 illustratively comprise abrasive regions 310 on tissue removal surface 302 of the  
8 device. The abrasive regions may, for example, comprise a diamond or oxide coating  
9 on surface 302. Abrasive regions 310a, 310b, 310c, 310d, etc., become progressively  
10 less abrasive between reel 312 and reel 314. In this manner, the location where tissue  
11 is selectively removed may be smoothed or sanded with a progressively finer 'grit' as  
12 surface 302 moves across the tissue in a single direction from reel 314 to reel 312.

13 [0387] Tissue removal device 300 may be tapered, such that the width of the device  
14 increases as it is wound between the reels to provide for a gradual decompression.  
15 The device optionally may comprise measuring elements 316, such as sensors or  
16 progressively larger sounds, for determining the effectiveness of decompression,  
17 thereby providing the medical practitioner with an indicator for when the reels may be  
18 advanced. Tissue removal surface 302 optionally may comprise section 316 that  
19 contacts the tissue surface after selective tissue removal for delivery of bone wax,  
20 hemostatic agents such as thrombin, antiproliferative agents, steroids, non-steroidal  
21 anti-inflammatory drugs, or any other therapeutic agent.

22 [0388] In one variation, the device includes a compression dressing as illustrated in  
23 the percutaneous embodiment described above in FIGS. 63 and 64. Following  
24 neuroforaminal and lateral recess enlargement, it may be advantageous to leave, as a  
25 surgical dressing, a belt or ribbon pulled tightly against the abraded tissue surface. It



1 is expected that a compression dressing will enhance hemostasis, promote healing and  
2 promote subsequent tissue remodeling with the neural foramen widely open.

3 Furthermore, the surgical dressing would provide a barrier to trap tissue debris away  
4 from neural or neurovascular structures, while providing an optional technique for  
5 delivering medication, possibly as a depot, to the operative site. The dressing would  
6 also present a smooth surface towards the nerve root in the immediate post-operative  
7 period.

8 [0389] The neuroforaminal compression dressing may, in one preferred embodiment,  
9 comprise the optional protective sheath, percutaneously held tightly in place against  
10 the abraded surface, after the abrasive apparatus has been removed from its lumen, for  
11 a period of time. Alternatively or additionally, a separate percutaneously removable  
12 compression dressing may be placed following tissue abrasion. The abrasive material  
13 may be followed by a length of compression dressing material on the same reel or  
14 spool, or a subsequent reel or spool. Alternatively, a compression dressing may be  
15 delivered through the neural foramen as a separate element. The compression  
16 element may also be used to deliver medications or other bioactive components (e.g.  
17 steroid, biodegradable adhesion barriers, etc.), to the surgical site. The compression  
18 dressing material may be, in one variation, partially or completely biodegradable. An  
19 entirely biodegradable compression dressing may be placed tightly against the  
20 abraded surface, and left completely implanted following the procedure.

21 [0390] Whether placing the apparatus with an epidural needle 2; through the working  
22 channel of an epidural needle 50; with an epidural endoscope; or during an open  
23 surgical procedure; image guidance may be used to facilitate safe and accurate  
24 placement. If the epidural needle 2 has been replaced by, or converted to, an  
25 endoscope, direct visualization of the epidural space 42 may be accomplished. In this



1 case, as illustrated in FIGS. 103-104, the clear tip of the fiberoptic scope will facilitate  
2 visualization through the fat present in the epidural space 42. The fiberoptic cable  
3 may be rigid or flexible, with the flat surface of its distal tip 66 perpendicular ( $0^\circ$ , for  
4 straight ahead viewing) or at an angle (e.g.  $30^\circ$ ,  $45^\circ$ , or  $60^\circ$ ). The cannula may be  
5 closed at its end, as in FIGS. 103-114, covering and protecting the distal end of the  
6 fiberoptic cable with a clear tip 74 which may be solid, fluid, or gas filled, potentially  
7 sized and shaped to expand the area of viewing within the fat filled epidural space 42.  
8 Additionally the endoscope or "needlescope" may contain an additional channel or  
9 space for infusion of fluid into the epidural space, in order to facilitate visualization,  
10 to create a space for visualization, and/or to decrease bleeding by increasing pressure,  
11 towards or above venous pressure, within the viewing area.

12 [0391] FIGS. 103 through 114 illustrate several embodiments of closed tip portals for  
13 epidural fiberoptic visualization. Some description of these portals may be found in  
14 the text above. Basically, the portals show several preferred variations of designs that  
15 enable visualization through the fat that exists in the epidural space. The clear tips of  
16 the portals may be solid and clear, or may contain air or clear liquid. The volume of  
17 the tip creates a space for improved perspective during visualization.

18 [0392] Referring now to FIGS. 103, a hockey stick shaped portal facilitates steering  
19 of the portal by rotation of the device. Such a design may be used with a flexible,  
20 partially flexible, or rigid fiberoptic element 64. Besides steering the portal tip, the  
21 fiberoptic element may be rotated separately in order to direct visualization, when  
22 angled scope tips are used (e.g.  $30^\circ$ ,  $45^\circ$ ,  $60^\circ$ ). Alternative embodiments, as  
23 illustrated in FIGS. 107, may allow the tip of the instrument to be steered. FIGS. 109-  
24 111, 113, and 114 illustrate means of delivering tools along with the epidural  
25 endoscopic portals. Finally, FIGS. 112 show a couple of different shapes of the many

1 possible variations that may be helpful in improving visualization and access to the  
2 central canal, lateral recesses, neural foramen and posterior annulus of the spine.

3 **[0393]** Figure 115 illustrates that a percutaneous access element, for example the  
4 epidural needle 2, can be deployed in the epidural space 42. The needle 464 can have  
5 a sharpened distal needle tip 466. The needle 464 needle 464 can be deployed via  
6 percutaneous or open procedures described herein. The needle 464 can be deployed  
7 via percutaneous access to the lateral recess and neural foramen 110. The needle 464  
8 can be inserted at or one level below the spinal interspace where tissue removal is  
9 desired. The needle 464 can be inserted into the epidural space 42 midline, ipsilateral,  
10 or contralateral to the area where the spinal canal, lateral recess and/or neuroforaminal  
11 stenosis or impingement is to be treated. Percutaneous access can be aided by image  
12 guidance, an epidural endoscope, any other visualization technique, or combinations  
13 thereof.

14 **[0394]** The needle 464 can have multiple barrels or lumen, for example a first lumen  
15 and a second lumen (not shown). The first lumen can extend distally of the second  
16 lumen. The first lumen and/or the second lumen can terminate in open or closed  
17 configurations at the needle tip 466.

18 **[0395]** Figure 116 illustrates that a catheter 24 can then be deployed through the  
19 needle 464 and into the epidural space 42, as shown by arrow. The catheter distal tip  
20 can have a protective hood 460 or a needle cap, for example, over the needle tip 466.

21 **[0396]** Figure 117 illustrates that when the catheter 24 has been placed in the epidural  
22 space 42, the user can open the hood 460, as shown by arrows.

23 **[0397]** Figure 118 illustrates that after the hood 460 is opened, the catheter 24 can be  
24 slidably retracted through the needle 464 until the hood 460 firmly covers the needle  
25 tip 466. When the hood 460 firmly covers the needle tip 466, the catheter 24 can be

1 fixed to the needle 464. The needle 464 with the hood covering the needle tip 466 can  
2 be a blunt instrument.

3 **[0398]** Figure 119 illustrates that the needle 464 can be advanced, as shown by arrow,  
4 until the needle tip 466 is in a lateral recess 108, adjacent to the neural foramina 110..  
5 The user can position the needle tip 466 adjacent to the lateral recess 108 using tactile  
6 feedback from the needle 464, image guidance (e.g. fluoroscopy), or combinations  
7 thereof.

8 **[0399]** Figure 120 illustrates that a neural stimulation and localization device 114 can  
9 be attached to the catheter 24 and/or needle 464 and or a device within the needle or  
10 catheter, for example a tissue protection barrier (not shown). The neural stimulation  
11 and localization device 114 can have a controller. The neural stimulation and  
12 localization device 114 can be configured to selectively deliver and/or sense electrical  
13 current.

14 **[0400]** The user can visualize the epidural space 42, for example, via a fiber optic  
15 element (not shown). The fiber optic element can be covered by a clear distal tip.  
16 The fiber optic element can be deployed to the epidural space 42 integral with, or  
17 separate from but within, the catheter 24. The fiber optic element can be deployed to  
18 the epidural space 42 integral with, or separate from but within, the needle 464. The  
19 fiber optic element can be deployed to the epidural space 42 via a working space  
20 adjacent the needle 464. The user can deploy an epidural endoscope, for example, to  
21 visualize the epidural space 42 including the lateral recess 108 and neural foramen  
22 110.

23 **[0401]** An access element (not shown) that can have a cannulated probe such as a  
24 cannulated ball-tipped probe, Woodson elevator, or Hockey Stick hybrid, can be  
25 placed into the epidural space 42. A curved element, such as an atraumatic needle,



1 can then be advanced through the cannula of the probe and into the neural foramen

2 110. The curved element can cannulate the neural foramen 110.

3 [0402] Figure 121 illustrates that a tissue protection element or barrier 528 can be

4 deployed through or with the needle 464, and/or the catheter 24, and/or a

5 supplemental curved needle (not shown), and/or a shield (not shown), as shown by

6 arrows. The tissue protection barrier 528 can be part of a tissue removal apparatus.

7 The tissue removal apparatus can be further comprised by the needle, and/or hood.

8 [0403] The tissue protection barrier can be deployed into the lateral recess 108 and/or

9 the neural foramen 110. The tissue protection barrier 528 can be deployed between

10 the tissue to be removed, for example the impinging tissue 424, and the tissue to be

11 protected, for example, the dura mater 46 and associated neural (e.g., spinal cord,

12 nerve roots, dorsal root ganglion) and neurovascular structures. The tissue protection

13 barrier 528 can have contracted and expanded configurations. During deployment,

14 the tissue protection barrier 528 can be in the contracted or expanded configurations.

15 The tissue protection barrier 528 can be separate from, or integral with, the catheter

16 24 and/or needle 464. The tissue protection barrier 528 in a contracted configuration

17 can be slidably attached to the catheter 24 and/or the needle 464.

18 [0404] The tissue protection barrier 528 can have an atraumatic profile. The tissue

19 protection barrier 528 can have rounded edges. The tissue protection barrier 528 can

20 be a catheter, curved or straight needle, curved or straight shield, sheath, backstop,

21 stent, net, screen, mesh or weave, panel, fan, coil, plate, balloon, accordioning panels,

22 or combinations thereof. The tissue protection barrier 528 can have a tapered

23 configuration.

24 [0405] The tissue protection barrier 528 can have a front side (i.e., working side) and

25 a back side (i.e., neural protection side). The front side 456 can be electrically

1 isolated from the back side 428. The front side 456 can have an electrically  
2 conductive surface. The back side 428 can have an electrically conductive surface.  
3 The neural stimulation and localization device 114 can be in electrical communication  
4 with the front side 456 and/or the back side 428.

5 [0406] Neural stimulation can be monitored via spinal somatosensory-evoked  
6 potentials (SSEPs), motor-evoked potentials (MEPs), and/or by looking for visual  
7 signs of muscular contraction within the extremities. SSEP, SEP, MEP or  
8 electromyogram (EMG) feedback can be monitored and/or recorded visually, and/or  
9 can be monitored audibly, potentially conveying quantitative feedback related to the  
10 volume or frequency of the auditory signal (e.g. a quantitative auditory feedback).  
11 Intensity of signal or stimulation can be monitored and used to localize the nerve  
12 during placement.

13 [0407] The neural stimulation and localization device 114 can deliver electrical  
14 current to the front side 462. If there is a nervous system response, the tissue  
15 protection barrier 528 can be retracted and redeployed with the front side and the back  
16 side switched. The neural stimulation and localization device 114 can then deliver  
17 electrical current to the front side 456 again and the tissue protection barrier 528 can  
18 be readjusted and redeployed until there is no nervous system response from  
19 delivering electrical current to the front side 456.

20 [0408] The neural stimulation and localization device 114 can deliver electrical  
21 current to the back side 428. If there is no nervous system response, the tissue  
22 protection barrier 528 can be retracted and redeployed with the front side and the back  
23 side switched. The neural stimulation and localization device 114 can then deliver  
24 electrical current to the back side 428 again and the tissue protection barrier 528 can



1 be redeployed and readjusted until there is a nervous system response from delivering  
2 electrical current to the back side 428.

3 [0409] The neural stimulation and localization device 114 can deliver electrical  
4 current to the back side 428 and the front side 456 and the tissue protection barrier  
5 528 can be readjusted and redeployed until there is a nervous system response from  
6 delivering electrical current to the back side 428 and no nervous system response  
7 from the front side 456.

8 [0410] The user can deploy to the neural foramen 110 and/or the lateral recess 108  
9 one or more surgical stimulating and monitoring instruments (e.g., cautery devices,  
10 graspers, shavers, burrs, probes, combinations thereof) that can selectively stimulate  
11 electrically while monitoring nerve stimulation. The surgical can quantify the  
12 stimulation to localize the neural tissue (e.g., dura mater, spinal cord, spinal root,  
13 dorsal root ganglion). For instance, the user can use a calibrated sensor input that  
14 recognizes stronger stimulation as the device is moved closer to neural structures.

15 [0411] Figure 122 illustrates that the tissue protection barrier 528 can be transformed,  
16 as shown by arrows, into the expanded configuration. The hood 460 can be retracted  
17 toward the needle 464. A balloon (not shown) can be inflated within the tissue  
18 protection barrier 528. The tissue protection barrier 528 can be twisted with respect  
19 to itself. An electrical current and/or heat can be applied to the tissue protection  
20 barrier 528, for example, that can be made from a shape memory alloy. The hood  
21 retracting, and/or balloon inflating, and/or tissue protection barrier 528 twisting with  
22 respect to itself, and/or heating can expand the tissue protection barrier 528.

23 [0412] A spring can be inside the tissue protection barrier 528. The tissue protection  
24 barrier can be the spring, for example when the tissue protection barrier 528 is or has  
25 a self-expandable stent or mesh. The spring can be releasably fixed in a compressed



1 state when the tissue protection barrier 528 is in the contracted configuration. When  
2 released, the spring can expand the tissue protection barrier 528. The spring can be  
3 released by a trigger mechanism.

4 **[0413]** The expansion of the tissue protection barrier 528 can apply a non-damaging  
5 pressure to the nerve branches 62. The tissue protection barrier 528 can have a  
6 window 536. The window 536 can be open in the contracted and/or expanded  
7 configuration of the tissue protection barrier 528.

8 **[0414]** Figure 123 illustrates that a tissue removal device 300 can be attached to,  
9 and/or slidably deployed along, through, around or over the needle 464 and/or the  
10 catheter 24. The tissue removal device 300 can be deployed between the impinging  
11 tissue 424 and the tissue protection barrier 528. The tissue removal device 300 can  
12 have a control handle extending from the proximal end of the needle 464. The tissue  
13 removal device 300 can be exposed to the impinging tissue through the window 536  
14 (e.g., needle ports 472).

15 **[0415]** The tissue removal device 300 can have an energy delivery system (not  
16 shown). The energy delivery system can be configured to deliver one or more  
17 energies to tissue adjacent to the energy delivery system. The energies can be  
18 configured to ablate, vaporize, break up, combinations thereof, or otherwise change  
19 the modulus of the tissue. The tissue removal device 300 can be configured to deliver  
20 electrical, ultrasound, thermal, microwave, laser, cryo (i.e., removing thermal energy),  
21 or combinations thereof.

22 **[0416]** The tissue removal device 300 can have one or more electrosurgery elements  
23 (not shown). The electrosurgery elements can be configured to remove and/or ablate  
24 tissue. The electrosurgery elements can achieve hemostasis and/or neural localization  
25 in tissue adjacent to the electrosurgery elements. The electrosurgery elements can

1 have monopolar or bipolar RF elements. The RF elements can be activated with a  
2 thermal or substantially non-thermal waveform.

3 [0417] The tissue removal device 300 can have or be lasers, high-pressure fluid,  
4 thermal elements, radioactive elements, textile electric conductors, conductive wire  
5 loops and/or needles configured to be used in tissue contact (e.g., needle ablation),  
6 springs, open and/or spring wire weaves, conductive polymers that can have  
7 conductive metals chemically deposited thereon, or combinations thereof.

8 [0418] Figure 124 illustrates that the tissue removal device 300, for example the  
9 energy delivery system, can transmit energy 44 to the tissue to be removed, for  
10 example, the impinging tissue 424. The energy 44 can alter the compression,  
11 denaturation, electrosurgical exposure, thermal remodeling (hot or cold), chemical  
12 alteration, epoxy or glues or hydrogels, modulus of elasticity, or any combination  
13 thereof of the impinging tissue 424. For example, the modulus of elasticity of soft  
14 impinging tissue 424 can be increased. An increased modulus of elasticity can  
15 improve purchase on the soft impinging tissue 424 with the tissue removal device  
16 300. Remodeling of the tissue during modulus alteration can alleviate impingement  
17 and obviate or reduce a need for tissue removal.

18 [0419] The tissue removal device 300 can be designed to automatically stimulate the  
19 site of tissue removal, or have the neural stimulation and localization device 114  
20 stimulate the site of tissue removal, before or during tissue removal. The tissue  
21 removal device 300 can be configured to automatically stop tissue removal when  
22 nerve stimulation is sensed by the front side 456, and/or no nerve stimulation is  
23 sensed by the back side 428.

24 [0420] Figure 125 illustrates that the tissue removal device 300 can have one or more  
25 non-powered mechanical tissue removal elements. The non-powered mechanical

1 tissue removal elements can be abrasives such as abrasive belts or ribbons, cutting  
2 elements such as blades, knives, scissors or saws, rongeurs, grinders, files, debriders,  
3 scrapers, graters, forks, picks, burrs, rasps, shavers, or combinations thereof.

4 **[0421]** An external activating force, for example as shown by arrow 530 (activating  
5 tissue removal) on a handle, can activate the tissue removal device 300, as shown by  
6 arrow 530 (tissue removal device operating). The mechanical tissue removal  
7 elements can be used in combination or not in combination with the energy delivery  
8 device. The mechanical tissue removal elements can be pushed into and/or drawn  
9 across the impinging tissue 424 to remove the tissue by cutting, shaving, slicing,  
10 scissoring, guillotining, scraping, tearing, abrading, debriding, poking, mutilating, or  
11 combinations thereof. The mechanical tissue removal elements (e.g., blades) can be  
12 drawn across the impinging tissue 424 in a single direction and/or can be reciprocated.  
13 The mechanical tissue removal elements can be manually controlled and/or  
14 electronically, pneumatically or hydraulically powered. The mechanical tissue  
15 removal elements can be embedded with abrasives and/or have abrasive coatings,  
16 such as a diamond or oxide coating.

17 **[0422]** The blades can have various shapes, sizes and configurations. The blades can  
18 coact, for example, in a guillotine-type or scissor-type cutting action. The blades can  
19 be attached to or integral with the tissue removal device. The blades can be formed  
20 by grinding, punching or stamping through the tissue removal device. The blades can  
21 be formed by grinding of a punched or stamped edge of the tissue removal device.  
22 The blades can be formed by a chemical etching process. The blades can have a 3-  
23 dimensional profile to facilitate cutting, for example, a bow or a corrugation or a  
24 'cheese grater' profile. The blades can be placed at one or more angles relative to the  
25 direction of tissue removal. The blades can be configured with the blade cutting



1 across the tissue (i.e., similar to a band saw). The blades can have cutting surfaces.

2 The cutting surfaces can be oriented in a single or multiple directions. The blades can  
3 be serrated.

4 [0423] The saw can be a wire saw or saws. The wire saw can be a Gigli saw.

5 Multiple wire saws or Gigli saws can be joined or woven together or flattened to form  
6 a substantially planar cutting surface. The wire saw can be mounted on a flat ribbon.

7 The ribbon can be a depth stop, for example, limiting for saw penetration.

8 [0424] The tissue removal device 300 can have one or more powered mechanical  
9 tissue removal elements. The powered mechanical tissue removal elements can have,  
10 for example, band saws, belt shavers, rotary burrs or blades, reciprocating burrs or  
11 blades, or combinations thereof.

12 [0425] Devices and elements known to those having ordinary skill in the art can be  
13 used to remove debris from, and/or irrigate, and/or provide suction to, the epidural  
14 space 42 including the lateral recess 108 and neural foramen 110 and/or to the tissue  
15 removal device itself. The devices and elements for removing debris can be integral  
16 with the needle 464 and/or the catheter 24. Debris removal, and/or suction and/or  
17 irrigation may be provided intermittently or continuously, as desired by the medical  
18 practitioner. Debris removal can include suction and/or irrigation. The tissue  
19 removal device 300 can capture debris. Irrigation and/or suction in the tissue removal  
20 device 300 can remove the debris from the tissue removal device 300, for example by  
21 the debris exiting along the needle 464 and/or catheter 24.

22 [0426] Figure 126 illustrates that when tissue removal device 300 removes enough  
23 impinging tissue to reduce the pressure on the neural (e.g., nerve roots, spinal cord,  
24 dorsal root ganglion) and neurovascular tissue, the tissue removal device 300 can be  
25 removed from the tissue protection barrier 528, and/or the needle 464, and/or the

1 catheter 24. The tissue removal device can be withdrawn from the skin 70, as shown  
2 in Figure 127.

3 [0427] Figure 128 illustrates that the tissue protection barrier 528 can be transformed  
4 into a contracted configuration, as shown by arrows. Figure 129 illustrates that the  
5 needle tip can be translatably retracted, as shown by arrow, from the neural foramen  
6 110 and lateral recess 108. Figure 130 illustrates that the needle can be translatably  
7 withdrawn from the spine 510 and the skin 70.

8 [0428] Figure 131 illustrates that the tissue protection barrier 528 can be slidably  
9 attached to a tissue removal device 300. The tissue removal device 300 can have one  
10 or more needles 468. The needles 468 can be configured to be individually  
11 slidable within the tissue removal device 300. The needles 468 can each have a  
12 needle tip 474. The needle tips 474 can be covered, coated or otherwise have a  
13 surface and/or be completely made from an electrically conductive material. The  
14 needle 468, for example other than the needle tip 474, can be covered, coated or  
15 otherwise have a surface made from an electrically resistive or insulating material.  
16 The surface of the needle tips 474 can be conductive. The needle tips 474 can be  
17 electrodes. The surface of the non-tip remainder of the needle 468 can be resistive  
18 and/or insulating.

19 [0429] The tissue removal device 300 can have an energy delivery system, such as  
20 including the neural stimulation and localization device 114 and the needle tips.  
21 The energy delivery system can be configured to deliver one or more energies to  
22 tissue adjacent to the energy delivery system. The energies can be configured to  
23 ablate, vaporize, break up, combinations thereof, or otherwise change the modulus of  
24 the tissue. The tissue removal device 300, for example via the needle tips 474, can



1 be configured to deliver electrical, ultrasound, thermal, microwave, laser, cryo (i.e.,  
2 removing thermal energy), or combinations thereof, energy 44.

3 **[0430]** The tissue removal device 300 can have one or more electrosurgery elements,  
4 for example the needlette tips 474. The electrosurgery elements can be configured to  
5 remove and/or ablate tissue. The electrosurgery elements can achieve hemostasis  
6 and/or neural localization in tissue adjacent to the electrosurgery elements. The  
7 electrosurgery elements can have monopolar or bipolar RF elements. The RF  
8 elements can be activated with a thermal or substantially non-thermal waveform.

9 **[0431]** The tissue removal device 300, for example at the needlette tips 474, can have  
10 or be lasers, high-pressure fluid, thermal elements, radioactive elements, textile  
11 electric conductors, conductive wire loops and/or needles configured to be used in  
12 tissue contact (e.g., needle ablation), springs, open and/or spring wire weaves,  
13 conductive polymers that can have conductive metals chemically deposited thereon,  
14 or combinations thereof.

15 **[0432]** Figures 132 and 133 illustrate that the needlettes 468 can be the tissue removal  
16 devices 300. The needlettes 468 can be slidably attached directly to the tissue  
17 protection barrier 528. The tissue protection barrier 528 (and/or tissue removal device  
18 300) can have one or more windows, for example needlette ports 472. The needlettes  
19 468 can be configured to slidably extend through the needlette ports 472. The  
20 needlette ports 472 can be on the front side 456. The needlette ports 472 can be on a  
21 working surface 538 of the tissue protection barrier 528 (as shown) or tissue removal  
22 device.

23 **[0433]** The tissue protection barrier 528 (and/or tissue removal device 300) can have  
24 needlette conduits 470. The needlettes can be slidably attached to needlette conduits  
25 470. The needlette 468 can be solid. The needlette 468 can be hollow. The needlette



1 468 can have a conducting wire (not shown) extending therethrough. The needlette  
2 tips 474 can be sharp or dull.

3 [0434] Figure 134 illustrates that the needlette tip 474 can have a shaper or scoop  
4 496, such as a grater or shredder. The scoop 496 can have a tissue entry port 524.  
5 The scoop 496 can be open and in fluid communication with a hollow needlette 468.  
6 The scoop 496 can have a leading edge 462, for example partially or completely  
7 around the perimeter of the tissue entry port 524. The leading edge 462 can be  
8 sharpened and/or dulled. The leading edge 462 can be beveled. The leading edge 462  
9 can be electrically conductive. The leading edge 462 can be configured to emit RF  
10 energy. The leading edge 462 can be a wire. The needlette tip 474 other than the  
11 leading edge can be electrically resistive.

12 [0435] Figure 135 illustrates that the needlette tip 474 can have a tip hole 520. The  
13 tip hole 520 can have a sharpened perimeter. The tip hole 520 can be the tissue entry  
14 port 524. The tip hole can be in fluid communication with the hollow needlette 468.

15 [0436] Figure 136 illustrates that the first needlette tips 474 can deploy, such as by  
16 translatably extending, as shown by arrow, from the tissue protection barrier 528 into  
17 the impinging tissue 424. The first needlette tips 474 can be configured to deploy in a  
18 first deployment direction.

19 [0437] Figures 137 and 138 illustrate that the second needlette tips 474 can deploy,  
20 such as by translatably extending, as shown by arrow, from the tissue protection  
21 barrier 528 into the impinging tissue 424. The needlette tips 474 can be deployed  
22 deeper than the surface of the impinging tissue 424.

23 [0438] The second needlette tips 474 can be configured to deploy in a second  
24 deployment direction. The first deployment direction can form a deployment angle  
25 with respect to the second deployment direction. The first deployment direction and

1 the second deployment direction can be configured to fixedly attach the first and second  
2 needle tips to the impinging tissue 424. The deployment angle can be from about  
3 90 degrees to about 270 degrees, more narrowly from about 90 degrees to about 180  
4 degrees, for example about 120 degrees (as shown in Figure 137).

5 [0439] Figures 139 and 143 illustrate that the needles 468, for example only  
6 through the needle tips 474, can deliver energy 44 into or onto the impinging tissue.  
7 The energy 44 can be acoustic, electrical (e.g., monopolar or bipolar RF), direct heat  
8 or cold, or combinations thereof. The energy 44 can ablate and/or evaporate the  
9 impinging tissue 424. The energy 44 can be delivered deeper than the surface of the  
10 impinging tissue 424. The energy 44 can be created and/or delivered to the needle  
11 tips 474 by the neural stimulation and localization device 114.

12 [0440] The tissue removal device 300, for example the energy delivery system, can  
13 transmit an energy 44 to the tissue to be removed, for example, the impinging tissue  
14 424. The energy 44 can alter the compression, denaturation, electrosurgical exposure,  
15 thermal remodeling (hot or cold), chemical alteration, epoxy or glues or hydrogels,  
16 modulus of elasticity, or any combination thereof of the impinging tissue 424. For  
17 example, the modulus of elasticity of soft impinging tissue 424 can be increased. An  
18 increased modulus of elasticity can improve purchase on the soft impinging tissue 424  
19 with the tissue removal device 300. Remodeling of the tissue during modulus  
20 alteration can alleviate impingement and obviate or reduce a need for tissue removal.

21 [0441] The tissue removal device 300 can be designed to automatically stimulate the  
22 site of tissue removal, or have the neural stimulation and localization device 114  
23 stimulate the site of tissue removal, before or during tissue removal. The tissue  
24 removal device 300 can be configured to automatically stop tissue removal when

1 nerve stimulation is sensed by the front side 456, and/or no nerve stimulation is  
2 sensed by the back side 428.

3 [0442] Figure 140 illustrates that the needles 468 can remove the impinging tissue  
4 424, for example by suction and/or debridement through holes in or adjacent to the  
5 needle tips 474.

6 [0443] Figure 141 illustrates that the second needle tips 474 can be retracted, as  
7 shown by arrow, into the tissue protection barrier 528. The first needle tips 474 can  
8 be retracted into the tissue protection barrier 528.

9 [0444] Figure 142 illustrates that the hood 460 can be retracted, as shown by arrow,  
10 onto the needle 464. The needle 464 can be withdrawn from the treatment site.

11 [0445] Figure 144 illustrates that the tissue removal apparatus can have the tissue  
12 removal device 300 and the tissue protection barrier 528. The tissue removal device  
13 300 can be slidably attached to an inside conduit, channel or hollow of the tissue  
14 protection barrier 528. The tissue removal device 300 can have the working surface  
15 538. The working surface 538 can be configured to damage, and/or destroy, and/or  
16 remove the impinging tissue. Part or all of the working surface 538 can be exposed  
17 through the window 536. The window 536 can be on the front side of the tissue  
18 protection barrier 528. The tissue barrier protection 528 can have and/or elute a  
19 lubricious coating or material, for example on the surface of the inside conduit,  
20 channel or hollow. The tissue removal device 300 can have and/or elute a lubricious  
21 coating or material on the entire surface and/or on the surface other than on the  
22 working surface 538.

23 [0446] Figure 145 illustrates that a method of using the tissue removal apparatus 538  
24 can include deploying the window adjacent to the impinging tissue 424. A tension, as  
25 shown by arrows 518, can be applied to the tissue protection barrier 528. The tissue



1 removal device 300 can be reciprocated or oscillated, as shown by arrows 476. The  
2 oscillation can, for example, result in the working surface 538 to separate impinging  
3 tissue 424. The separated impinging tissue 424 can be removed, for example by  
4 suction, through the tissue protection barrier 528 and/or the tissue removal device  
5 300. Section D can be equivalent to sections A, B, or C.

6 [0447] The working surface 538 can have one or more non-powered mechanical  
7 tissue removal elements. The non-powered mechanical tissue removal elements can  
8 be abrasives such as abrasive belts or ribbons, cutting elements such as blades, knives,  
9 scissors or saws, rongeurs, grinders, files, debriders, scrapers, graters, forks, picks,  
10 burrs, rasps, shavers, or combinations thereof.

11 [0448] The mechanical tissue removal elements can be used in combination or not in  
12 combination with the energy delivery device. The mechanical tissue removal  
13 elements can be pushed into and/or drawn across the impinging tissue 424 to remove  
14 the tissue by cutting, shaving, slicing, scissoring, guillotining, scraping, tearing,  
15 abrading, debriding, poking, mutilating, or combinations thereof. The mechanical  
16 tissue removal elements (e.g., blades) can be drawn across the impinging tissue 424 in  
17 a single direction and/or can be reciprocated. The mechanical tissue removal  
18 elements can be manually controlled and/or electronically, pneumatically or  
19 hydraulically powered. The mechanical tissue removal elements can be embedded  
20 with abrasives and/or have abrasive coatings, such as a diamond or oxide coating.

21 [0449] The blades can have various shapes, sizes and configurations. The blades can  
22 coact, for example, in a guillotine-type or scissor-type cutting action. The blades can  
23 be attached to or integral with the tissue removal device. The blades can be formed  
24 by grinding, punching or stamping through the tissue removal device. The blades can  
25 be formed by grinding of a punched or stamped edge of the tissue removal device.

1 The blades can be formed by a chemical etching process. The blades can have a 3-  
2 dimensional profile to facilitate cutting, for example, a bow or a corrugation or a  
3 'cheese grater' profile. The blades can be placed at one or more angles relative to the  
4 direction of tissue removal. The blades can be configured with the blade cutting  
5 across the tissue (i.e., similar to a band saw). The blades can have cutting surfaces.  
6 The cutting surfaces can be oriented in a single or multiple directions. The blades can  
7 be serrated.

8 [0450] The saw can be a wire saw or saws. The wire saw can be a Gigli saw.  
9 Multiple wire saws or Gigli saws can be joined or woven together or flattened to form  
10 a substantially planar cutting surface. The wire saw can be mounted on a flat ribbon.  
11 The ribbon can be a depth stop, for example, limiting for saw penetration.

12 [0451] The tissue removal device 300 can have one or more powered mechanical  
13 tissue removal elements. The powered mechanical tissue removal elements can have,  
14 for example, band saws, belt shavers, rotary burrs or blades, reciprocating burrs or  
15 blades, or combinations thereof.

16 [0452] Devices and elements known to those having ordinary skill in the art can be  
17 used to remove debris from, and/or irrigate, and/or provide suction to, the epidural  
18 space 42 including the lateral recess 108 and neural foramen 110 and/or to the tissue  
19 removal device itself. The devices and elements for removing debris can be integral  
20 with the needle 464 and/or the catheter 24. Debris removal, and/or suction and/or  
21 irrigation may be provided intermittently or continuously, as desired by the medical  
22 practitioner. Debris removal can include suction and/or irrigation. The tissue  
23 removal device 300 can capture debris. Irrigation and/or suction in the tissue removal  
24 device 300 can remove the debris from the tissue removal device 300, for example by  
25 the debris exiting along the needle 464 and/or catheter 24.

1 [0453] Figure 146 illustrates that the tissue protection barrier 528 can have a first rail  
2 452 and a second rail 500. The tissue protection barrier 528 can be rigid, flexible or  
3 combinations thereof. The tissue protection barrier 528 can be resilient or  
4 deformable. The first rail 452 and/or second rail 500 can be rounded to form  
5 atraumatic sides of the tissue protection barrier 528. The first rail 452 and/or second  
6 rail 500 can be configured to slidably attach to the tissue removal device 300. The  
7 first rail 452 and/or second rail 500 can be configured to snap fit and/or interference  
8 fit to the tissue removal device 300.

9 [0454] The tissue protection barrier 528 can have a tissue protection barrier test  
10 strength. The tissue protection barrier test strength can be equal to or less than about  
11 890 N (200 lbs.), more narrowly equal to or less than about 710 (160 lbs.), yet more  
12 narrowly equal to or less than about 350 N (80 lbs.), for example about 180 N (40  
13 lbs.).

14 [0455] The tissue protection barrier 528 can have a taper 516 at a first end. The taper  
15 516 can be configured to dissect tissue, for example, during deployment. The taper  
16 516 can be configured to bluntly dissect tissue, for example, during deployment. The  
17 taper 516 can be configured to be atraumatic, for example, not being able to  
18 substantially dissect tissue during deployment. The taper 516 can be configured to  
19 interference fit the tissue removal device 300.

20 [0456] Figure 147 illustrates that the tissue protection barrier 528 can have a wire,  
21 such as a distal wire 440. The distal wire 440 can be integral with, or fixedly attached  
22 to, the taper 516. The distal wire 440 can extend from the taper 516. The distal wire  
23 440 can have a wire test strength. The wire test strength can be equal to or less than  
24 about 890 N (200 lbs.), more narrowly equal to or less than about 710 (160 lbs.), yet



1 more narrowly equal to or less than about 350 N (80 lbs.), for example about 180 N  
2 (40 lbs.).

3 [0457] During use, the distal wire 440 and/or the taper 516 can be deployed  
4 posteriorly exiting the skin. During use, the distal wire 440 and/or the taper 516 can  
5 be deployed posteriorly around or through the spine, exiting the spine and deploying  
6 substantially to the site at which the needle and/or tissue protection barrier entered.  
7 The distal wire 440 and/or the taper 516 can be secured to a substantially fixed  
8 location (e.g., the skin, the spine, the user's hand). Additional force can be applied,  
9 for example, posteriorly on the tissue protection barrier (e.g., on the first end, and/or a  
10 second end). The tissue protection barrier 528 can be forced into the impinging tissue  
11 424.

12 [0458] Figure 148 illustrates that the distal wire 440 can be attached to a distal wire  
13 anchor 442. The distal wire anchor 442 can be fixedly or removably attached to the  
14 distal wire 440 after deployment of the distal wire 440 exiting the skin 70 and/or the  
15 spine 510. The distal wire anchor 442 can be integral with the distal wire 440. The  
16 distal wire anchor 442 can be expandable. The distal wire anchor 442 can be resilient  
17 or deformable. The distal wire anchor 442 can have a contracted configuration before  
18 deployment. The distal wire anchor 442 can be held in the contracted configuration  
19 by a removable sheath.

20 [0459] Figure 149 illustrates that the shield 528 or distal wire can be slidably and/or  
21 fixedly attached to a distal wire sleeve and/or anchor lock 442. The distal wire sleeve  
22 and/or anchor lock 442 can fix the distal wire anchor 442 to the distal wire 440, or  
23 may provide protection for the tissues while the wire is pulled through said distal  
24 sleeve 438. The distal wire sleeve 438 or anchor lock can interference fit and/or  
25 friction fit the distal wire anchor 442. The distal wire sleeve 438 or anchor lock can

1 be fixedly or removably attached to the distal wire 440 after deployment of the distal  
2 wire 440 exiting the skin and/or the spine. The distal wire sleeve 438 or anchor lock  
3 can be integral with the shield or backstop or distal wire. The distal wire sleeve 438  
4 or anchor lock can be expandable. The distal wire sleeve 438 or anchor lock can be  
5 resilient or deformable. The distal wire sleeve 438 or anchor lock can have a  
6 contracted configuration before deployment. The distal anchor lock 438 can be held  
7 in the contracted configuration by a removable sheath.

8 **[0460]** The distal anchor lock 438 can be integral with, or fixedly attached to, the  
9 taper 516. The distal anchor lock 438 can extend from the taper 516. The distal  
10 anchor lock 438 can have a test strength. The test strength can be equal to or less than  
11 about 890 N (200 lbs.), more narrowly equal to or less than about 710 (160 lbs.), yet  
12 more narrowly equal to or less than about 350 N (80 lbs.), for example about 180 N  
13 (40 lbs.).

14 **[0461]** The distal wire 440 can be integral with, or fixedly attached to, the tissue  
15 removal device 300 (not shown in Figure 149). The distal wire 440 can extend from  
16 the tissue removal device 300. The distal wire 440 can be slidably attached to the  
17 distal anchor lock 438. The tissue removal device 300 can be slidably attached to the  
18 tissue protection barrier 528. During use, the distal wire 440 can be slidably  
19 translated within the distal wire anchor 442. Translation of the distal wire 440 can  
20 slidably translate the tissue removal device 300. The tissue removal device 300 can  
21 be reciprocated, for example, when alternating translations are applied on either end  
22 of the tissue removal device 300, such as when applied by a distal wire 440 and/or a  
23 proximal wire.

24 **[0462]** Figure 150 illustrates that the tissue protection barrier 528 can have a first  
25 taper 516 at a first end and a second taper 516 at a second end. The tissue protection

1 barrier 528 can have a proximal wire 484 and a distal wire 440. The proximal wire  
2 484 can be integral with, or fixedly attached to, the first taper 516. The proximal wire  
3 484 can extend from the first taper 516. The distal wire 440 can be integral with, or  
4 fixedly attached to, the second taper 516. The distal wire 440 can extend from the  
5 second taper 516.

6 [0463] The tissue protection barrier 528 can have one or more wires and no tapers  
7 540. The wires can extend from be integral with, or fixedly attached to, and/or extend  
8 from non-tapered ends.

9 [0464] Figure 151 illustrates that the tissue protection barrier 528 can have a first  
10 taper 516 at a first end, a second taper 516 at a second end, a proximal wire 484, a  
11 distal wire 440, and a distal wire anchor 442 attached to, or integral with, the distal  
12 wire 440. Figure 152 illustrates that the tissue protection barrier 528 can have a first  
13 taper 516 at a first end, a second taper 516 at a second end, a proximal wire 484, a  
14 distal wire 440, a proximal wire anchor 482 attached to, or integral with, the proximal  
15 wire 484, and a distal wire anchor 442 attached to, or integral with, the distal wire  
16 440. Figure 153 illustrates that the tissue protection barrier 528 can have a first taper  
17 516 at a first end, a second taper 516 at a second end, a proximal wire 484, a distal  
18 wire 440, a proximal wire anchor 482 attached to, or integral with, the proximal wire  
19 484, and a distal wire anchor 442 attached to, or integral with, the distal wire 440.  
20 The distal wire 440 can be slidably and/or fixedly attached to a distal wire sleeve  
21 and/or anchor lock. The proximal wire 484 can be slidably and/or fixedly attached to  
22 a proximal wire sleeve and/or anchor lock 442. The distal wire sleeve 438 may be an  
23 extension of the neuroforaminal protection barrier 528, through which the wire 440 is  
24 passed in order to prevent damage through abrasion of vulnerable tissues.



1 [0465] Figure 154 illustrates that the tissue protection barrier 528 can have a port 478  
2 at a first end. The tissue removal device 300 can have a taper 516 at a first end. The  
3 tissue removal device 300 can have a leading end 462 at the first end. The leading  
4 edge 462 can be configured to be atraumatic. The tissue removal device 300 can have  
5 a first rail 452 and a second rail 500. The first rail 452 and/or the second rail 500 of  
6 the tissue removal device 300 can be configured to be atraumatic. The tissue  
7 protection barrier 528 can have a first rail and a second rail (not shown in Figures  
8 154-157).

9 [0466] Figure 32 illustrates that the leading edge 462 can be translatably inserted, as  
10 shown by arrow, into the port 478. The tissue protection barrier 528 can expand to  
11 receive the tissue removal device 300. The tissue protection barrier 528 can expand  
12 in a tapered configuration around the taper 516 of the tissue removal device 300. The  
13 first rail 452 and/or the second rail 500 of the tissue removal device 300 can slidably  
14 attach to the first rail and/or the second rail of the tissue protection barrier 528.

15 [0467] Figure 156 illustrates that the tissue removal device can be further translatably  
16 inserted, as shown by arrow, into the tissue protection barrier 528.

17 [0468] Figure 157 illustrates that the tissue removal device 300 can be further  
18 translatably inserted, as shown by arrow, into the tissue protection barrier 528. The  
19 window 536 can expose the tissue removal device 300 on the front side 456 of the  
20 tissue protection barrier 528. The tissue removal device 300 can snap fit, interference  
21 fit, friction fit, or otherwise fix to the tissue protection barrier 528, for example when  
22 the tissue removal device 300 has been inserted to a required length into the tissue  
23 protection barrier 528.

24 [0469] Figure 158 illustrates that the tissue removal device 300 can have one or more  
25 tissue conduits 522. The tissue conduits 522 can be channels or conduits. The tissue

1 conduits 522 can be open at a tissue entry port 478 and/or a tissue exit 526. A leading  
2 edge 462 can be around or adjacent to the perimeter of the tissue entry port 478. The  
3 leading edge 462 can be a conductor (e.g., and RF device, such as a wire). The  
4 leading edge 462 can be sharp and/or dull. The leading edge 462 can be beveled.  
5 Pairs of tissue entry ports 524 can oppose each other, as shown, thereby enabling  
6 removal of tissue when the tissue removal device is translated in both longitudinal  
7 directions. During use, the separated tissue can be removed via the tissue conduits  
8 522.

9 [0470] Figures 159 and 160 illustrate that the tissue removal device 300 can have  
10 shapers or scoops 496, such as graters or shredders. The scoops 496 can have tissue  
11 entry port 478. The scoops 496 can be open and in fluid communication with one or  
12 more tissue conduits. The scoops 496 can have leading edges 462, for example  
13 partially or completely around the perimeter of the tissue entry port 478. The leading  
14 edge 462 can be sharpened and/or dulled. The leading edge 462 can be electrically  
15 conductive. The leading edge 462 can be configured to emit RF energy. The leading  
16 edge 462 can be a wire. The tissue removal device 300 other than the leading edge  
17 462 can be electrically resistive and/or insulating.

18 [0471] Figure 161 illustrates that the tissue removal device 300 can have springs 512.  
19 The springs 512 can be fixedly or removably attached to the tissue removal device  
20 300. The springs 512 can be attached through the tissue removal device 300, for  
21 example into the tissue conduit 522. The tissue removal device 300 can open into the  
22 tissue conduit 522 where the springs 512 attach, for example, sufficient to allowing  
23 fluid communication through the tissue removal device. The springs can be  
24 sharpened and/or dulled. The springs 512 can have flat ribbon coils, and or other  
25 coils configured to cut the impinging tissue.

1 [0472] Figure 162 illustrates that the tissue removal device 300 can be expanded, as  
2 shown by arrows. The springs 512 can expand and/or contract with the tissue  
3 removal device.

4 [0473] Figure 163 illustrates that the spring 512 can be fixedly or removably attached  
5 to, or integral with, a base 430. The base 430 can be made from, for example, a high  
6 temperature epoxy (e.g., from Epoxy Technology, Billerica, MA), a high temperature  
7 plastic, or combinations thereof. High temperature plastics can include, for example,  
8 liquid crystal polymer, polysulfones, or polyimide.

9 [0474] The springs 512 can be in electrical communication with a circuit, for example  
10 the neural stimulation and localization device. The circuit can have a ground 116, a  
11 power source 480, and a switch 514. The power source 480 can have a frequency  
12 range from about 100 kHz to about 10 MHz. The springs 512 can be grounded at one  
13 or more points. The circuit can create a monopolar spring 512. The base 430 can  
14 electrically insulate the spring 512 and the remainder of the tissue removal device 300  
15 (e.g., a ribbon). The circuit can be closed during use.

16 [0475] The spring 512 can have various configurations to alter the cutting  
17 performance. For example, the spring can have a circular configuration.

18 [0476] The springs 512 can emit low level voltage prior to tissue removal, for  
19 example, to check for nerve stimulation.

20 [0477] Figure 164 illustrates that the tissue removal device 300 can have a first spring  
21 512 and a second spring 512. The first spring 512 can be separated from the second  
22 spring 512 by a gap distance 458. The gap distance 458 can be from about 100  $\mu\text{m}$  to  
23 about 5 cm. The first spring 512 and the second spring 512 can be concurrently  
24 attached to the circuit. The first spring 512 can be in direct electrical communication  
25 with the second spring 512.



1 [0478] The impedance between the first spring 512 and the second spring 512 can be  
2 monitored. For example, if the impedance exceeds threshold values (e.g., the  
3 impedance of burning tissue), the circuit can be configured to open.

4 [0479] Figure 165 illustrates that the tissue removal device can have multiple springs  
5 512. The springs 512 can be in electrical communication with a controller 434 in the  
6 circuit. The controller 434 can transmit current to any combination of springs 512.  
7 The controller 434 can monitor the impedance between springs 512. The controller  
8 434 can open the circuit to a particular spring if the impedance exceeds a threshold.

9 [0480] Figure 166 illustrates the tissue removal device 300 that can have the springs  
10 512 in a non-contracted (e.g., expanded) configuration. Figure 167 illustrates that the  
11 sides of the tissue removal device 300 can be folded, as shown by arrows, to contract  
12 the tissue removal device 300, for example for deployment or retraction from a  
13 patient's body. The springs 512 can contract and/or expand with the contraction  
14 and/or expansion of the tissue removal device 300.

15 [0481] Figure 168 illustrates the tissue removal apparatus 300 that can be partially  
16 deployed percutaneously (i.e., through the skin 70) in the spine. Figure 169 illustrates  
17 that the distal wire 440 can be translatably extended, as shown by arrow, from the  
18 distal end of the tissue protection barrier 528. Figure 170 illustrates that the distal  
19 wire 440 can translatably extend, as shown by arrow, through the skin 70. Figure 171  
20 illustrates that a distal wire anchor 442 can removably attach to the distal wire 440.  
21 The distal wire 440 can be fixed, for example, at the surface of the skin 70.

22 [0482] Figure 172 illustrates that the leading edge 462 can be pressed into the  
23 impinging tissue 424, for example as a result of the tension 518 on the tissue  
24 protection barrier 528 and/or tension applied to the tissue removal device 300 during  
25 the oscillation 479. The leading edge 462 can purchase the impinging tissue 424.

1 The leading edge 462 can be activated, for example be delivering RF energy to the  
2 leading edge.

3 [0483] Figure 173 illustrates that the tissue removal device 300 can be translated, as  
4 shown by arrow 534, with respect to the impinging tissue 424. The leading edge 462  
5 can cut into the impinging tissue 424. The scoop 496 can force separation, as shown  
6 by arrow 506, of the cut impinging tissue 424 from the remaining impinging tissue  
7 424.

8 [0484] Figure 174 illustrates that the removed tissue 488 can be removed from the  
9 tissue removal device 300 (as shown) or the tissue protection barrier 528, for example  
10 by suction.

11 [0485] Figures 175 and 176 illustrate that the tissue removal apparatus 300 can have a  
12 deployment cover 436 over the tissue protection cover 528 prior to, and during,  
13 deployment. The deployment cover 436 can be slidably attached to the tissue removal  
14 device 300. The tissue removal device 300 can be expandable, for example a self-  
15 expandable coil spring. The tissue protection barrier 528 can be expandable, for  
16 example a self-expandable coil-reinforced polymer tube (e.g., a stent-graft). The  
17 deployment cover 436 can be rigid, for example, to prevent the tissue removal device  
18 300 and/or the tissue protection barrier 528 from expanding. The tissue removal  
19 device 300 and/or tissue protection barrier 528 can be manually expandable, for  
20 example by having an integrated or attached mechanical expansion device (e.g., an  
21 inflation balloon) and/or from being made from shape memory alloy that reconfigures  
22 when heated.

23 [0486] Figure 177 illustrates that the deployment cover 436 can be retracted, as  
24 shown by arrow 492. The tissue protection barrier 528 not covered by the  
25 deployment cover 436 can radially expand, as shown by arrows 492. For example,

1 the tissue removal device 300 and/or the tissue protection barrier can self-expand  
2 and/or manually expand.

3 [0487] Figure 178 illustrates that the deployment cover 436 can be retracted, as  
4 shown by arrow 492. The window 536 can be exposed. The deployment cover 436  
5 can be completely removed from the tissue protection barrier 528. The tissue  
6 protection barrier 528 can be re-covered by the deployment cover 436, for example,  
7 immediately before the tissue protection barrier 528 is removed from the treatment  
8 site.

9 [0488] Figure 179 illustrates that the tissue removal device can be the spring 512, for  
10 example a coil spring. The spring 512 can be in a flat configuration in the tissue  
11 protection barrier 528. The spring 512 can be slidably attached to the tissue  
12 protection barrier 528.

13 [0489] Figure 180 illustrates that the spring 512 can be translated, as shown by arrow  
14 532. The spring can have a first spring section 544 not along the length of the  
15 window 536. The spring 512 can have and a second spring section 504 along the  
16 length of the window 536. The first spring section 544 can be in the flat  
17 configuration. As the spring 512 translates from the first spring section 544 to the  
18 second spring section 504, the spring 512 can expand, as shown by arrow 446, into a  
19 completely and/or partially expanded configuration. As the spring 512 translates from  
20 the second spring section 504 to the first spring section 544, the spring 512 can  
21 contract into a flat configuration and retract, as shown by arrow 492, into the tissue  
22 protection barrier 528.

23 [0490] Figures 181 illustrates the deployment cover 436 that can have the tissue  
24 protection barrier 528 inside the deployment cover 436. Figure 182 illustrates that the  
25 deployment cover 436 can translatably retract, as shown by arrow, from the tissue



1 protection barrier 528. The tissue protection barrier 528 can be in a non-expanded  
2 (e.g., contracted) configuration. Figure 183 illustrates that the tissue protection  
3 barrier 528 can then expand after, but not as a direct result of, the retraction of the  
4 deployment cover 436. The tissue protection barrier 528 can self-expand or be  
5 manually expanded. Figure 184 illustrates that the deployment cover 436 can be  
6 translatably retracted, as shown by arrow, from the entire tissue protection barrier  
7 528. Figure 185 illustrates the tissue protection barrier 528 in a deployed and  
8 expanded configuration.

9 [0491] Figure 186 illustrates the deployment cover 436 that can have the tissue  
10 protection barrier 528 inside the deployment cover 436. Figure 187 illustrates that the  
11 deployment cover can retract, as shown by arrow 492, from the tissue protection  
12 barrier 528. The tissue protection barrier 528 can then expand as a direct result of the  
13 retraction of the deployment cover 436. The tissue protection barrier 528 can self-  
14 expand or be manually expanded. For example, the manual expansion can be driven  
15 or triggered by the retraction of the deployment cover 436.

16 [0492] The tissue protection barrier, and/or the access elements, and/or the neural  
17 protection element and/or the tissue removal device can have a lubricious coating, for  
18 example, a hydrophilic coating, a poly(tetrafluoroethylene) coating. The coating can  
19 reduce friction during placement, diagnosis, treatment and/or removal. The tissue  
20 removal device, the access elements and/or the neural protection element can be  
21 biocompatible and/or non-friable.

22 [0493] Any of the elements and/or entire apparatuses described herein can be made  
23 from, for example, a single or multiple stainless steel alloys, nickel titanium alloys  
24 (e.g., Nitinol), cobalt-chrome alloys (e.g., ELGILOY® from Elgin Specialty Metals,  
25 Elgin, IL; CONICHROME® from Carpenter Metals Corp., Wyomissing, PA),

1 molybdenum alloys (e.g., molybdenum TZM alloy, for example as disclosed in  
2 International Pub. No. WO 03/082363 A2, published 9 October 2003, which is herein  
3 incorporated by reference in its entirety), tungsten-rhenium alloys, for example, as  
4 disclosed in International Pub. No. WO 03/082363, polymers such as polyester (e.g.,  
5 DACRON® from E. I. Du Pont de Nemours and Company, Wilmington, DE), carbon  
6 fiber composites (e.g., carbon fiber nylon composite, such as carbon fiber reinforced  
7 nylon 66), polypropylene, polytetrafluoroethylene (PTFE), expanded PTFE (ePTFE),  
8 polyether ether ketone (PEEK), nylon, polyether-block co-polyamide polymers (e.g.,  
9 PEBAX® from ATOFINA, Paris, France), aliphatic polyether polyurethanes (e.g.,  
10 TECOFLEX® from Thermedics Polymer Products, Wilmington, MA), polyvinyl  
11 chloride (PVC), polyurethane, thermoplastic, fluorinated ethylene propylene (FEP),  
12 absorbable or resorbable polymers such as polyglycolic acid (PGA), polylactic acid  
13 (PLA), polydioxanone, and pseudo-polyamino tyrosine-based acids, extruded  
14 collagen, silicone, zinc, echogenic, radioactive, radiopaque materials or combinations  
15 thereof. Examples of radiopaque materials are barium sulfate, zinc oxide, titanium,  
16 stainless steel, nickel-titanium alloys, tantalum and gold.

17 **[0494]** Any of the elements and/or entire apparatuses described herein can be or have  
18 a matrix for cell ingrowth or used with a fabric, for example a covering (not shown)  
19 that acts as a matrix for cell ingrowth. The matrix and/or fabric can be, for example,  
20 polyester (e.g., DACRON® from E. I. du Pont de Nemours and Company,  
21 Wilmington, DE), polypropylene, PTFE, ePTFE, nylon, extruded collagen, silicone or  
22 combinations thereof.

23 **[0495]** Any of the elements and/or entire apparatuses described herein can be filled  
24 and/or coated with an agent delivery matrix known to one having ordinary skill in the  
25 art and/or a therapeutic and/or diagnostic agent. The agents within these matrices can

1 include radioactive materials; radiopaque materials; cytogenic agents; cytotoxic  
2 agents; cytostatic agents; thrombogenic agents, for example polyurethane, cellulose  
3 acetate polymer mixed with bismuth trioxide, and ethylene vinyl alcohol; lubricious,  
4 hydrophilic materials; phosphor cholene; anti-inflammatory agents, for example non-  
5 steroidal anti-inflammatories (NSAIDs) such as cyclooxygenase-1 (COX-1) inhibitors  
6 (e.g., acetylsalicylic acid, for example ASPIRIN® from Bayer AG, Leverkusen,  
7 Germany; ibuprofen, for example ADVIL® from Wyeth, Collegeville, PA;  
8 indomethacin; mefenamic acid), COX-2 inhibitors (e.g., VIOXX® from Merck &  
9 Co., Inc., Whitehouse Station, NJ; CELEBREX® from Pharmacia Corp., Peapack,  
10 NJ; COX-1 inhibitors); immunosuppressive agents, for example Sirolimus  
11 (RAPAMUNE®, from Wyeth, , Collegeville, PA), or matrix metalloproteinase  
12 (MMP) inhibitors (e.g., tetracycline and tetracycline derivatives) that act early within  
13 the pathways of an inflammatory response. Examples of other agents are provided in  
14 Walton et al, Inhibition of Prostaglandin E<sub>2</sub> Synthesis in Abdominal Aortic  
15 Aneurysms, *Circulation*, July 6, 1999, 48-54; Tambiah et al, Provocation of  
16 Experimental Aortic Inflammation Mediators and Chlamydia Pneumoniae, *Brit. J.*  
17 *Surgery* 88 (7), 935-940; Franklin et al, Uptake of Tetracycline by Aortic Aneurysm  
18 Wall and Its Effect on Inflammation and Proteolysis, *Brit. J. Surgery* 86 (6), 771-775;  
19 Xu et al, Sp1 Increases Expression of Cyclooxygenase-2 in Hypoxic Vascular  
20 Endothelium, *J. Biological Chemistry* 275 (32) 24583-24589; and Pyo et al, Targeted  
21 Gene Disruption of Matrix Metalloproteinase-9 (Gelatinase B) Suppresses  
22 Development of Experimental Abdominal Aortic Aneurysms, *J. Clinical Investigation*  
23 105 (11), 1641-1649 which are all incorporated by reference in their entireties.  
24 [0496] Many of the safety issues related to the methods and apparatus described  
25 herein are similar to those associated with any surgical procedure, e.g., infection



1 and/or bleeding. Some safety issues are more specific to surgery in and around the  
2 spine or spinal cord, and are therefore given special consideration below. These  
3 generally relate to spinal neural and neurovascular injury. Central Nervous System  
4 injury could result from instruments inadvertently traumatizing the dura mater when  
5 entering the epidural space, injuring the nerve root (s), the adjacent vasculature, or the  
6 dorsal root ganglion as the apparatus is advanced and utilized towards and through the  
7 neural foramen.

8 **[0497]** Several techniques may be used to reduce a risk of dural, neural or  
9 neurovascular injury, including potentially traumatizing structures including nerve  
10 roots, adjacent vasculature, or dorsal root ganglia. For example, the tissue alteration  
11 (e.g., abrasion) devices may be placed under direct visualization when utilizing an  
12 open surgical approach or technique. Likewise, image guidance may be provided  
13 during placement or to confirm correct placement. Candidate image guidance  
14 techniques include fluoroscopy, fluoroscopy alone, fluoroscopy with additional  
15 technology for triangulation and tracking of instruments (e.g. infrared, RF, etc.), MRI,  
16 CT, OCT, ultrasound, etc. Catheters or guidewires may include their own image  
17 guidance capabilities such as catheter or guidewire-based image guidance, e.g.,  
18 fiberoptic visualization, catheter-based ultrasound, catheter-based MRI, optical  
19 tomography, etc. Alternatively or additionally, endoscopic visualization may be  
20 utilized (e.g. flexible fiberoptic endoscope as in Epiduroscope, or via rigid surgical  
21 endoscopes), during placement and/or post-placement confirmation of correct  
22 placement.

23 **[0498]** In addition to epidural endoscopy, image guidance may be combined with the  
24 use of straight, curved, or steerable guidewires for the proper placement of the  
25 neuroforaminal abrasive element. Placement may be achieved percutaneously or

1 through a surgical incision. Such a device may be implanted as an adjunct to an open  
2 surgical procedure(s); as an adjunct to an endoscopic surgical procedure(s); or as a  
3 separate open, image-guided percutaneous or endoscopic surgical procedure.

4 Percutaneous approaches will enable the surgeon to perform the procedure under local  
5 anesthetic in awake or sedated patients, if desired. As discussed, nerve stimulation  
6 and localization capabilities may be added to the device in order to enable the surgeon  
7 to more safely perform the procedure in an anesthetized, but un-paralyzed patient.

8 **[0499]** It is expected that the apparatus and methods of the present invention will  
9 facilitate a minimally invasive approach to the selective elimination (e.g., alteration,  
10 ablation, removal) of pathological spinal tissue, thereby enabling symptomatic relief  
11 in patients suffering from spinal stenosis. Spinal neural and neurovascular  
12 impingement cause tremendous pain and disability, with symptoms that include back  
13 and leg pain, weakness, and decreased sensation. Neural ischemia and injury caused  
14 by compression and inflammation may result in a wide range of symptoms or degrees  
15 of nerve damage. Symptoms range in severity from mild to severe, and from  
16 intermittent to permanent. For example, neurogenic claudication, which is  
17 exacerbated by back extension (as occurs when one stands erect and places the spine  
18 in extension), may be mild or severe. Symptoms of neurogenic claudication are  
19 usually improved by changes in posture that lead to back flexion, such as sitting. The  
20 most severe cases of spinal stenosis may lead to permanent neurological damage,  
21 including the possibility of the development of cauda equina syndrome.

22 **[0500]** Spine surgeons lack safe and effective techniques or tools to minimally  
23 invasively or percutaneously reduce neural and neurovascular impingement in the  
24 spine, while minimizing collateral tissue damage. It is expected that the apparatus  
25 and methods of the present invention may be utilized for lateral recess and

1 neuroforaminal enlargement to provide adequate bone and soft tissue resection, while  
2 reducing unnecessary destruction of functional bone, ligament or muscle in order to  
3 gain access to the tissues to be resected.

4 **[0501]** Spine surgeons lack safe and effective techniques or tools to minimally  
5 invasively or percutaneously reduce neural and neurovascular impingement in the  
6 spine, while minimizing collateral tissue damage. It is expected that the apparatus  
7 and methods of the present invention may be utilized to provide adequate bone and  
8 soft tissue resection to achieve lateral recess, neuroforaminal, and spinal canal  
9 enlargement, while reducing unnecessary destruction of functional bone, ligament or  
10 muscle in gaining access to the tissues to be modified.

11 **[0502]** Because critical neural and neurovascular structures are in close proximity to  
12 the areas where surgical manipulation, dissection, resection, ablation and remodeling  
13 would be therapeutically valuable in the spine, safety at each step in the procedure is  
14 of critical importance in order to avoid disabling neurological damage to the patient.  
15 For this reason, safety measures, such as working barriers and nerve localization via  
16 an integrated nerve stimulator, are described.

17 **[0503]** It may be desirable to alter an elastic modulus of impinging tissue to facilitate  
18 removal of the tissue. For example, it may be desirable to increase the modulus of  
19 soft tissue to gain purchase on the soft tissue with the tissue removal elements. Such  
20 modulus alteration may be achieved, for example, through compression, denaturation,  
21 electrosurgical exposure, thermal remodeling (hot or cold), chemical alteration, epoxy  
22 or glues or hydrogels, or any combination thereof, etc. Remodeling of the tissue  
23 during modulus alteration may alleviate impingement and obviate or reduce a need for  
24 tissue removal.



1 [0504] In order to reduce friction during placement, diagnosis, treatment and/or  
2 removal, the open or percutaneous access elements, neural protection element 200  
3 and/or tissue removal device 300 may comprise a lubricious coating, for example, a  
4 hydrophilic coating, a poly(tetrafluoroethylene) coating, etc. Furthermore, the tissue  
5 removal device, the access elements and/or the neural protection element may be  
6 biocompatible and/or non-friable. Integrated or separate debris removal elements also  
7 may be provided.

8 [0505] It is expected that the apparatus and methods of the present invention will  
9 facilitate selective elimination of pathological spinal tissue, thereby enabling  
10 symptomatic relief in patients suffering from spinal stenosis.

11 [0506] Spine surgeons presently lack safe and effective techniques or tools to  
12 minimally invasively or percutaneously reduce neural and neurovascular impingement  
13 in the spine, while minimizing collateral tissue damage. It is expected that the  
14 apparatus and methods of the present invention may be utilized for lateral recess and  
15 neuroforaminal enlargement to provide adequate bone and soft tissue resection, while  
16 reducing unnecessary destruction of functional bone, ligament or muscle in order to  
17 gain access to the tissues to be resected.

18 [0507] Because critical neural and neurovascular structures are in close proximity to  
19 the areas where surgical manipulation, dissection and remodeling would be  
20 therapeutically valuable in the spine, safety at each step in the procedure is of critical  
21 importance in order to avoid disabling neurological damage to the patient. For this  
22 reason, safety measures, such as neural protection element 200 and neural localization  
23 element 210, may be provided.

24 [0508] It will be apparent to those skilled in the art that various changes and  
25 modifications can be made thereto. For example, elements of any of the described

1 variations may be used in any combination, as desired. Furthermore, the apparatus  
2 described herein may be used for a variety of selective tissue removal procedures in  
3 addition to neural foraminal tissue impingement. For example, the apparatus may be  
4 used for treatment of central spinal stenosis. Further, the methods and apparatus  
5 described hereinafter are equally applicable to both open and percutaneous  
6 approaches. For the purpose of clarity, they have been disclosed utilizing only a  
7 percutaneous or open access, but this shall not be construed as limiting.

8 **[0509]** Although preferred illustrative embodiments of the present invention are  
9 described hereinabove, it will be apparent to those skilled in the art that various  
10 changes and modifications may be made thereto without departing from the invention.  
11 It is intended in the appended claims to cover all such changes and modifications that  
12 fall within the true spirit and scope of the invention.

1

## CLAIMS

2 We claim:

3 1. A surgical tissue removal system, comprising:

4 a flexible elongate body that is adapted to conform with the target anatomy,  
5 the body having at least one blade edge, where the blade edge is flush with a surface  
6 of the elongate body, where the flexible elongate body further comprises a profile  
7 having a width that is substantially greater than a height;

8 a barrier having at least one window, where the flexible body is slidably  
9 located within the barrier such that when the elongate body moves within the barrier  
10 the blade edges move across the window.

11 2. The tissue removal system of claim 1, where the window comprises a  
12 protective cover that is slidably located in the barrier, such that removal of the cover  
13 exposes the at least one blade edge.

14 3. The tissue removal system of claim 1, where the flexible elongate body  
15 comprises a low profile having a width that is substantially greater than a height of the  
16 flexible elongate body. The tissue removal system of claim 1, where the at least one  
17 blade edge comprises a plurality of blade edges that are formed by openings in the  
18 flexible elongate body.

19 4. The tissue removal system of claim 3, where the blade edges are formed from  
20 at least two sides of the opening to allow for bi-directional cutting of tissue.

21 5. The tissue removal system of claim 1, where the blade edges comprise a shape  
22 selected from the group consisting of a serrated edge, a scalloped edge and a smooth  
23 edge.

24 6. The tissue removal system of claim 1, where the at least one blade edge  
25 comprises a plurality of paired blade edges where each blade in the paired blade edges  
26 intersects another

27 7. The tissue removal system of claim 1, where the at least one blade edge is  
28 formed on at least one edge of the flexible elongate member.



- 1 8. The tissue removal system of claim 7, further comprising additional openings  
2 in the body of the flexible elongate member and where the additional openings  
3 comprise additional blade edges.
- 4 9. The tissue removal system of claim 1, where the at least one blade edge  
5 comprises a plurality of blade edges and where the plurality of blade edges are formed  
6 on at least both edges of the flexible elongate member.
- 7 10. The tissue removal system of claim 1, where the window comprises at least  
8 one window edge.
- 9 11. tissue removal system of claim 10, where the at least one window edge  
10 comprises a plurality of window edges.
- 11 12. The tissue removal system of claim 10, where the at least one window edge is  
12 sharpened.
- 13 13. The tissue removal system of claim 10, where the at least one window edge is  
14 conductive.
- 15 14. The tissue removal system of claim 13, where the at least one window edge is  
16 electrically coupled to a power supply to enable hemostasis of tissue or neural  
17 localization.
- 18 15. The tissue removal system of claim 1, where the width of the flexible elongate  
19 body varies along the length of the system.
- 20 16. The tissue removal system of claim 1, further comprising at least one rail  
21 being located within a portion of the barrier or attached to the flexible elongate body.
- 22 17. The tissue removal system of claim 1, where the barrier is coupled to at least  
23 one of a vacuum source to provide suction or an irrigation source.
- 24 18. The tissue removal system of claim 1, where at least a portion of the flexible  
25 elongate body includes a lubricious layer.
- 26 19. The tissue removal system of claim 1, where at least a portion of the barrier  
27 includes a lubricious layer.

- 1 20. The tissue removal system of claim 1, further comprising a motor coupled to  
2 at least a portion of the elongate body.
- 3 21. The tissue removal system of claim 1, further comprising at least one  
4 measuring elements coupled to the elongate body.
- 5 22. The tissue removal system of claim 21, where the at least one measuring  
6 element comprises a sensor or a sound.
- 7 23. The tissue removal system of claim 1, where the flexible elongate body is  
8 ribbon shaped.
- 9 24. The tissue removal system of claim 1, wherein the flexible elongated body  
10 further comprises at least one electrode.
- 11 25. The tissue removal system of claim 1, wherein the barrier further comprises at  
12 least one electrode.
- 13 26. A tissue removal system, comprising:  
14 a flexible elongate body, the body having a plurality of needlette ports on a  
15 working surface of the elongate body, and a plurality of cannula conduits within the  
16 body, each conduit being fluidly coupled to at least one needlette port;  
17 a plurality of needlettes slidably located in at least a portion of the needlette  
18 ports, such that a distal tip of the needlettes may advance and withdraw from the  
19 needeltte port.
- 20 27. The tissue removal system of claim 26, where the needlette are coupled to a  
21 power supply selected from the group consisting of electrical, ultrasound, thermal,  
22 microwave, laser, cryo, and a combination thereof.
- 23 28. A surgical tissue removal system, comprising:  
24 a flexible elongate body, the body having at least one tissue removal element  
25 having at least one blade edge, where the tissue removal element is coupled to at least  
26 one driveshaft such that the driveshaft causes the tissue removal element to move;  
27 a barrier having at least one window, where the flexible body is slidably  
28 located within the barrier such that when the elongate body moves within the barrier

1 the blade edges move across the window;

2 a motor coupled to the driveshaft.

3 29. A surgical tissue removal system, comprising:

4 a flexible elongate body that is adapted to conform with the target anatomy,  
5 the body having at least one blade edge, where the blade edge is flush with a surface  
6 of the elongate body, where the flexible elongate body further comprises a profile  
7 having a width that is substantially greater than a height.

8 30. The tissue removal system of claim 29, where the flexible elongate body  
9 comprises a low profile having a width that is greater than a height of the flexible  
10 elongate body.

11 31. The tissue removal system of claim 29, where the at least one blade edge  
12 comprises a plurality of blade edges that are formed by openings in the flexible  
13 elongate body.

14 32. The tissue removal system of claim 31, where the blade edges are formed from  
15 at least two sides of the opening to allow for bi-directional cutting of tissue.

16 33. The tissue removal system of claim 29, where the blade edges comprise a  
17 shape selected from the group consisting of a serrated edge, a scalloped edge and a  
18 smooth edge.

19 34. The tissue removal system of claim 29, where the at least one blade edge  
20 comprises a plurality of paired blade edges where each blade in the paired blade edges  
21 intersects another.

22 35. The tissue removal system of claim 29, where the at least one blade edge is  
23 formed on at least one edge of the flexible elongate member.

24 36. The tissue removal system of claim 35, further comprising additional openings  
25 in the body of the flexible elongate member and where the additional openings  
26 comprise additional blade edges.



1 37. The tissue removal system of claim 29, where the at least one blade edge  
2 comprises a plurality of blade edges and where the plurality of blade edges are formed  
3 on at least both edges of the flexible elongate member.

4 38. The tissue removal system of claim 29, where the width of the flexible  
5 elongate body varies along the length of the system.

6 39. The tissue removal system of claim 29, where at least a portion of the flexible  
7 elongate body includes a lubricious layer.

8 40. The tissue removal system of claim 29, further comprising a motor coupled to  
9 at least a portion of the elongate body.

10 41. The tissue removal system of claim 29, further comprising at least one  
11 measuring elements coupled to the elongate body.

12 42. The tissue removal system of claim 41, where the at least one measuring  
13 element comprises a sensor or a sound.

14 43. The tissue removal system of claim 27, wherein the flexible elongated body  
15 further comprises at least one electrode.

16 44. The tissue removal system of claim 27, where the flexible elongate body is  
17 ribbon shaped.

18 45. A surgical tissue removal system, comprising:  
19 a flexible elongate body, where the flexible elongate body comprises a low  
20 profile having a width that is substantially greater than a height of the flexible  
21 elongate body, the body having at least one blade edge, where the blade edge is flush  
22 with a surface of the elongate body, wherein the flexible elongated body further  
23 comprises at least one electrode for assessing the proximity of neural tissue to the  
24 blade edge.

25 46. A surgical tissue removal system, comprising:  
26 a flexible elongate body, where the flexible elongate body comprises a low  
27 profile having a width that is substantially greater than a height of the flexible  
28 elongate body, the body having at least one blade edge, where the blade edge is flush

1 with a surface of the elongate body, a barrier having at least one window, where the  
2 flexible body is slidably located within the barrier such that when the elongate body  
3 moves within the barrier the blade edges move across the window, wherein the barrier  
4 further comprises at least one electrode for assessing the proximity of neural tissue to  
5 the blade edge.

6 47. A surgical tissue modification device for use with a nerve stimulation  
7 apparatus, the tissue modification device comprising:  
8 an elongate flexible body;  
9 at least one tissue modification surface located on the body;  
10 at least one electrode attached to the body; and  
11 a connector for electrically coupling the electrode to the nerve stimulation  
12 apparatus.

13 48. The surgical tissue modification device of claim 47, further comprising at least  
14 one barrier located over a portion of the tissue modification surface.

15 49. The surgical tissue modification device of claim 48, where the barrier further  
16 comprises at least one opening such that the opening forms a window for the tissue  
17 modification surface to contact tissue when the barrier is placed over the tissue  
18 modification surface.

19 50. The surgical tissue modification device of claim 48, where the barrier is  
20 slidable relative to the tissue modification surface.

21 51. The surgical tissue modification device of claim 48, where at least one  
22 electrode is located on the barrier.

23 52. The surgical tissue modification device of claim 48, where the at least one  
24 electrode comprises at least two electrodes, where the electrodes are located in at least  
25 one of the following combinations, one on each side of the flexible body, one on each  
26 side of the barrier, one on the tissue modification side of the flexible body and one on  
27 the opposite side of the barrier.

1 53. The surgical tissue modification device of claim 47, where the tissue  
2 modification surface is located on a first side of the flexible body and the electrode is  
3 located on the first side of the body.

4 54. The surgical tissue modification device of claim 47, where the tissue  
5 modification surface comprises a plurality of grooves.

6 55. The surgical tissue modification device of claim 47, where the tissue  
7 modification surface comprises a plurality of perforations.

8 56. The surgical tissue modification device of claim 47, where the flexible body  
9 comprises a shape selected from the group consisting of a flat shape, a ribbon shape,  
10 and a tubular shape.

11 57. The surgical tissue modification device of claim 47, further comprising at least  
12 one medication or bioactive component for delivery to the tissue located on the tissue  
13 modification surface.

14 58. The surgical tissue modification device of claim 57, where the medication or  
15 bioactive component is selected from a substance from the group consisting of  
16 steroids, procoagulants, bone wax, and adhesion barriers.

17 59. A medical device for accessing tissue, the device comprising:  
18 a cannula having a sharp tip at a distal end thereof, the cannula further  
19 comprising a lumen extending therethrough and exiting out of the distal end at an  
20 opening;  
21 a second member having a distal section comprising an atraumatic protective  
22 cover, where the second member is slidably located within the cannula lumen, and  
23 where the distal section fits within the cannula lumen, and upon exiting the cannula  
24 lumen the protective cover is able to prevent the sharp tip from contacting tissue.

25 60. The medical device of claim 59, where the distal section is located on a distal  
26 end of the second member.

27 61. The medical device of claim 59, where the distal section is located proximal to  
28 a distal end of the second member.



1 62. The medical device of claim 59, where the distal section assumes a reduced  
2 profile when located in the cannula lumen.

3 63. The medical device of claim 59, where the distal section changes shape such  
4 that it can cover the sharp tip of the cannula.

5 64. The medical device of claim 5, wherein changing the shape of the distal  
6 section is accomplished by expanding the distal section such that it can be expanded  
7 to fit over the sharp tip of the cannula.

8 65. The medical device of claim 59, where the distal section is expandable such  
9 that it can be expanded to fit over the sharp tip of the cannula.

10 66. The medical device of claim 59, where the second member comprises a  
11 fiberoptic cable extending through at least a portion of the second member.

12 67. The medical device of claim 59, further comprising at least one anchor  
13 mechanism located on the second member.

14 68. The medical device of claim 59, further comprising at least one anchor  
15 mechanism located on the cannula.

16 69. The medical device of claim 59, where the cannula distal end is curved.

17 70. The medical device of claim 59, where the cannula body comprises at least a  
18 second lumen extending parallel to the first lumen.

19 71. The medical device of claim 59, where the cannula body comprises at least  
20 one channel located along a first side of the cannula, where the opening is located  
21 towards the distal end on the first side of the cannula, further comprising an  
22 instrument having at least one protrusion, where the protrusion is slidably located in  
23 the channel such that the instrument may be advanced relative to the cannula in fixed  
24 alignment.

25 72. The medical device of claim 71, where the instrument comprises an instrument  
26 selected from the group consisting of radio frequency device, lasers, rasps, ronguers,  
27 graspers, burrs, sanders, drills, shavers, visualization devices, guidewire and probes.

28

1 73. The medical device of claim 59, where the cannula body comprises at least  
2 one protrusion located along a first side of the cannula, where the protrusion is located  
3 towards the distal end on the first side of the cannula, further comprising an  
4 instrument having at least one channel, where the protrusion is slidably located in the  
5 channel such that the instrument may be advanced relative to the cannula in fixed  
6 alignment.

7 74. The medical device of claim 73, where the instrument comprises an instrument  
8 selected from the group consisting of radio frequency device, lasers, rasps, ronguers,  
9 graspers, burrs, sanders, drills, shavers, visualization devices, guidewire and probes.  
10

11 75. The medical device of claim 74, where the instrument further comprises a  
12 flexible flat distal section, where the flexible flat distal section is configured to be  
13 advanced through the lumen of the access device body and upon exiting from the  
14 access device body can expand to form a barrier.

15 76. The medical device of claim 59, further comprising at least one conductive  
16 element located on a distal end of the cannula.

17 77. A system for use in treating tissue, the system comprising:  
18 a cannula;  
19 a barrier device comprising an elongate member having a flexible flat distal  
20 section, where the flexible flat distal section is configured to be advanced through the  
21 lumen of the cannula and after exiting from the cannula can expand to form a shield  
22 having a cross sectional area greater than that of the lumen of the cannula; and  
23 at least one electrode located on the barrier, the electrode adapted to be  
24 coupled to a neural locating device.

25 78. The system of claim 1, further comprising a second electrode on the barrier  
26 device, where the second electrode is adapted to be coupled to the neural locating  
27 device.

28 79. The system of claim 1, further comprising a cannula electrode located on the  
29 cannula, where the cannula electrode is adapted to be coupled to the neural locating  
30 device.

1 80. A surgical barrier device for use with a nerve locating apparatus, the  
2 barrier device comprising:  
3 an elongate member having a flexible flat distal section, where the flexible flat  
4 distal section is configured to be collapsible to reduce in profile;  
5 at least one electrode attached to the flat distal section; and  
6 a connector for electrically coupling the electrode to the nerve locating  
7 apparatus.

8 81. The surgical barrier of claim 4, where the electrode is located on at least a top  
9 or bottom surface of the flat distal section.

10 82. The surgical barrier of claim 4, where the at least one electrode comprises at  
11 least two electrodes, and where an electrode is located on a top and bottom surface of  
12 the flat distal section.

13 83. The surgical barrier of claim 4, wherein the flat distal section is steerable.

14 84. A device for treating a spinal condition in a patient, comprising:  
15 a cannulated device with a sharp tip adapted to penetrate tissue and enter an  
16 epidural space;  
17 an atraumatic protective cover, when placed adjacent to the sharp tip of the  
18 cannulated device, blunts the sharp tip preventing the sharp tip from penetrating  
19 tissue; and  
20 an elongate member, moveable through the cannulated device, the elongate  
21 member having a first surface and a second surface, the first surface being adapted to  
22 face a first direction in the patient and a second surface adapted to face in an opposite  
23 direction, the first surface being adapted to remove tissue and the second surface  
24 being adapted to protect tissue

25 85. The device of claim 84 further comprising at least one stimulating electrode  
26 coupled to at least one of the surfaces.

27 86. The device of claim 84, wherein said second surface is a flexible barrier.

28



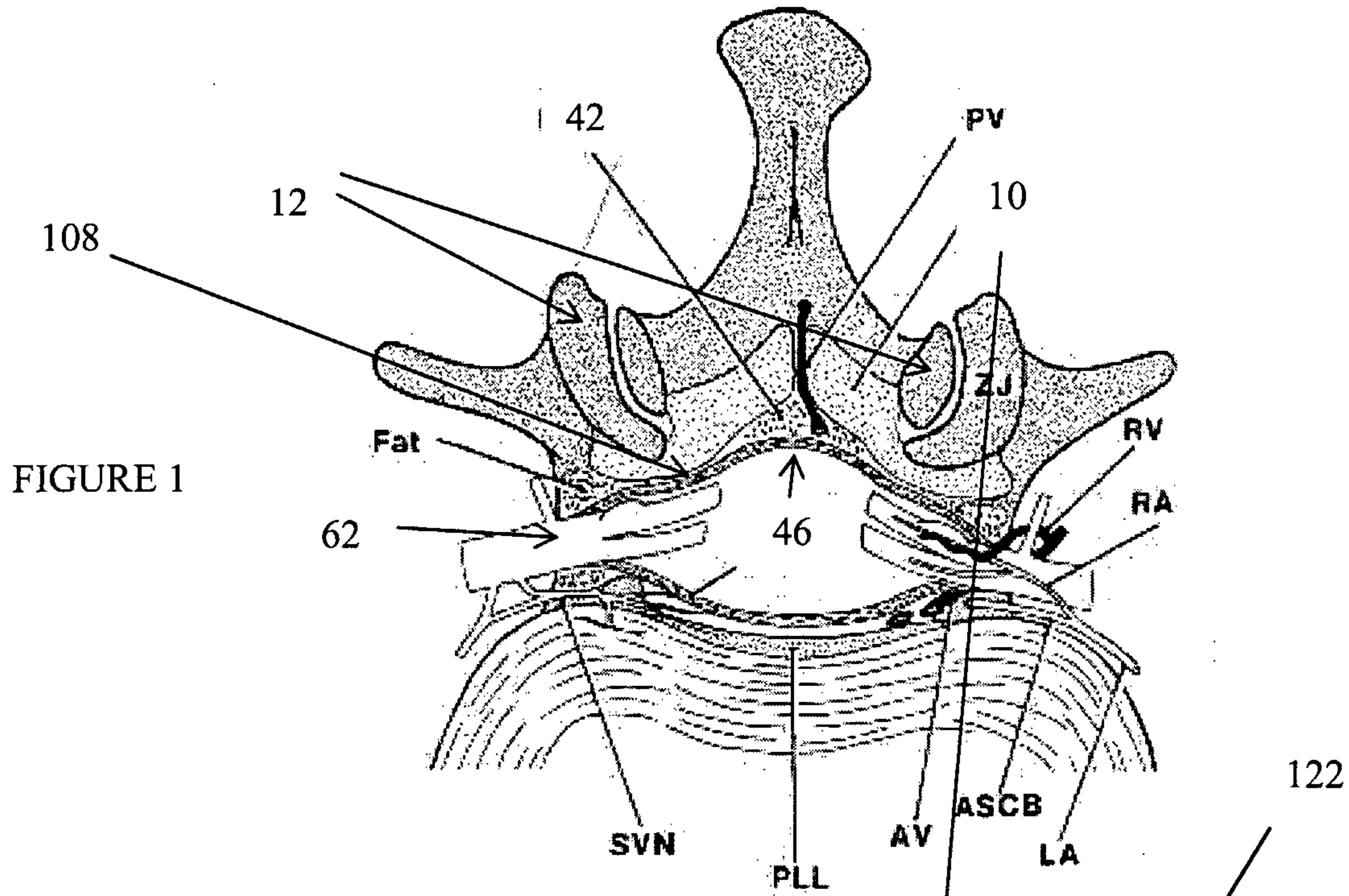

FIGURE 1

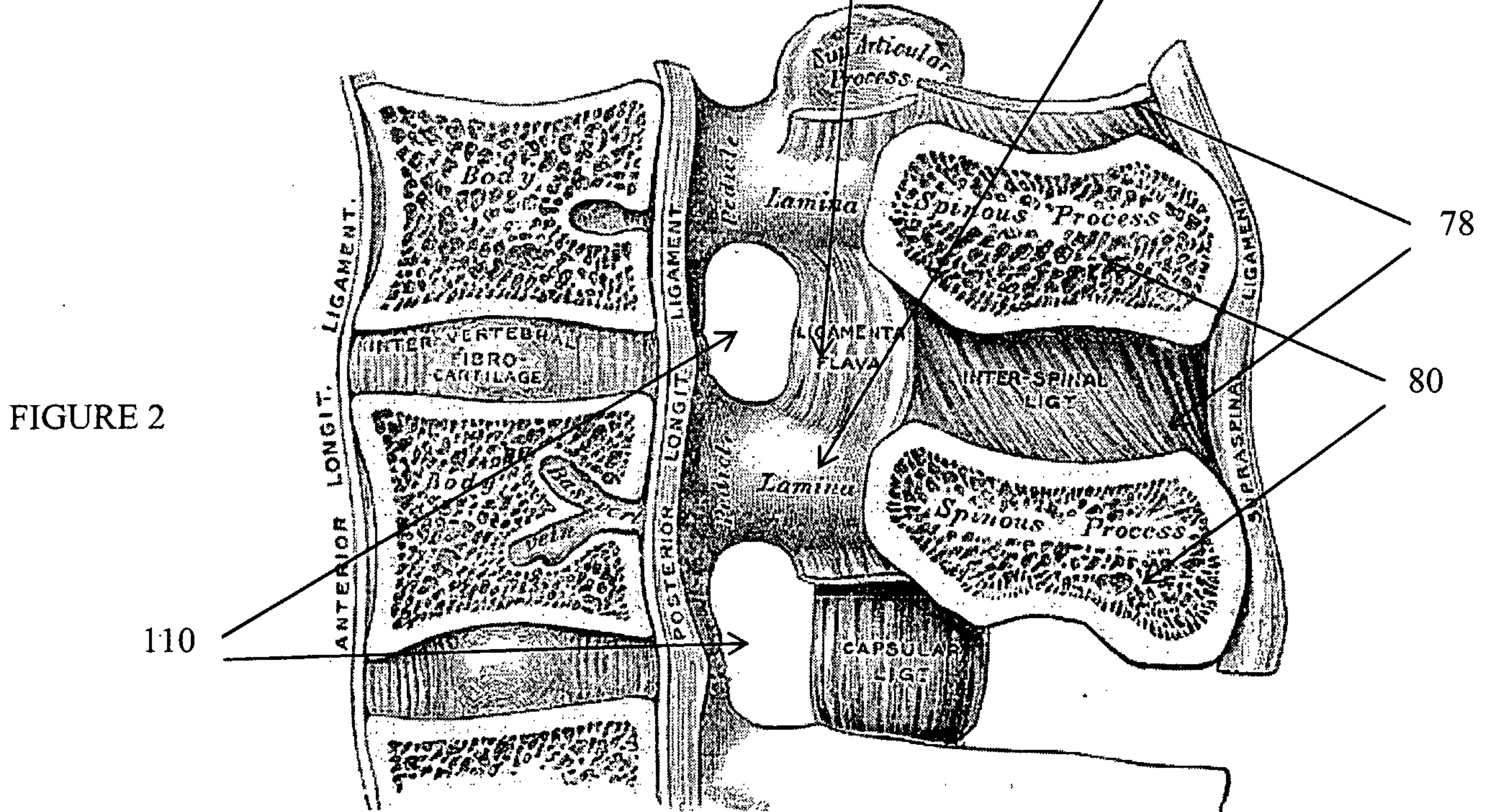

FIGURE 2



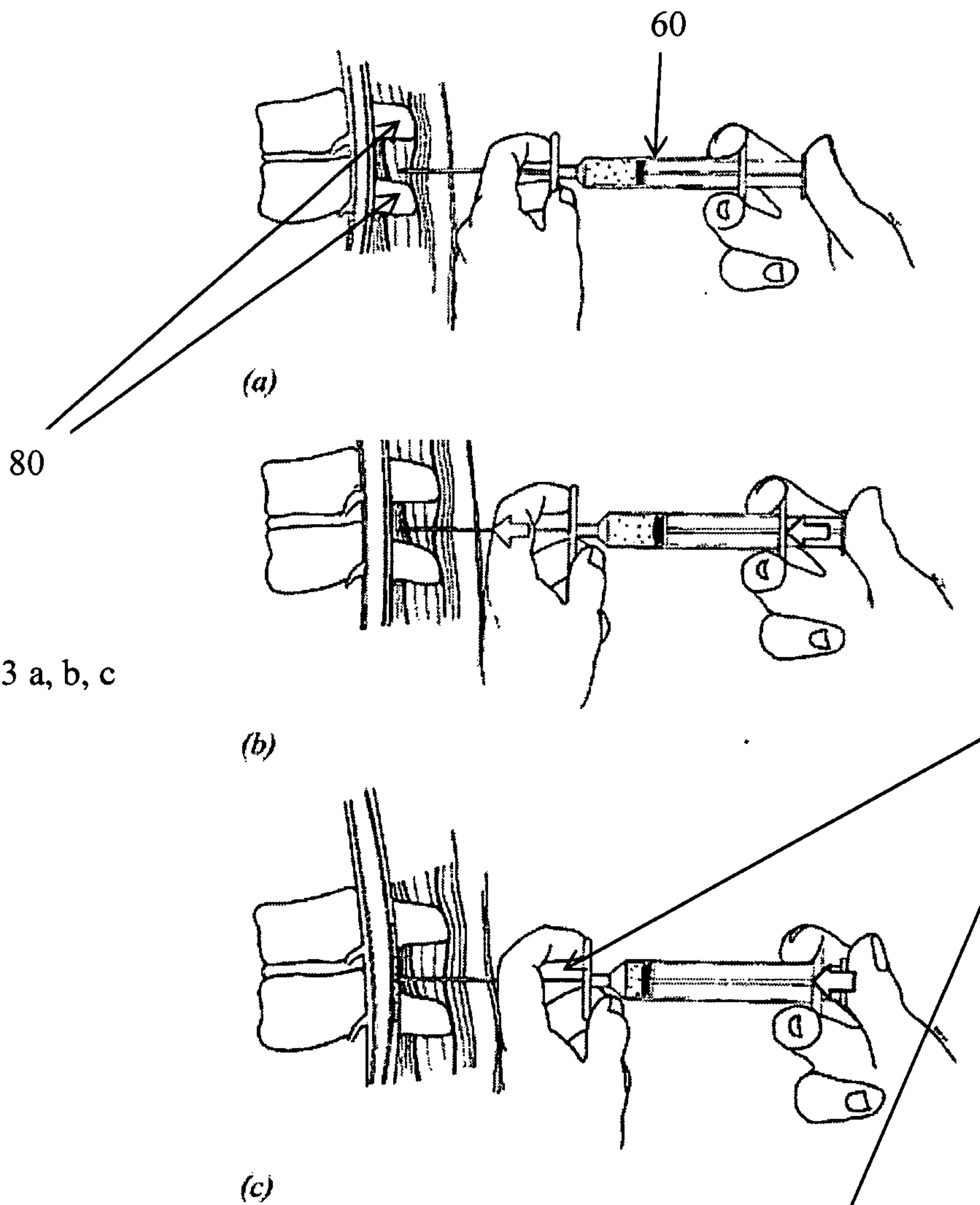

FIGURE 3 a, b, c

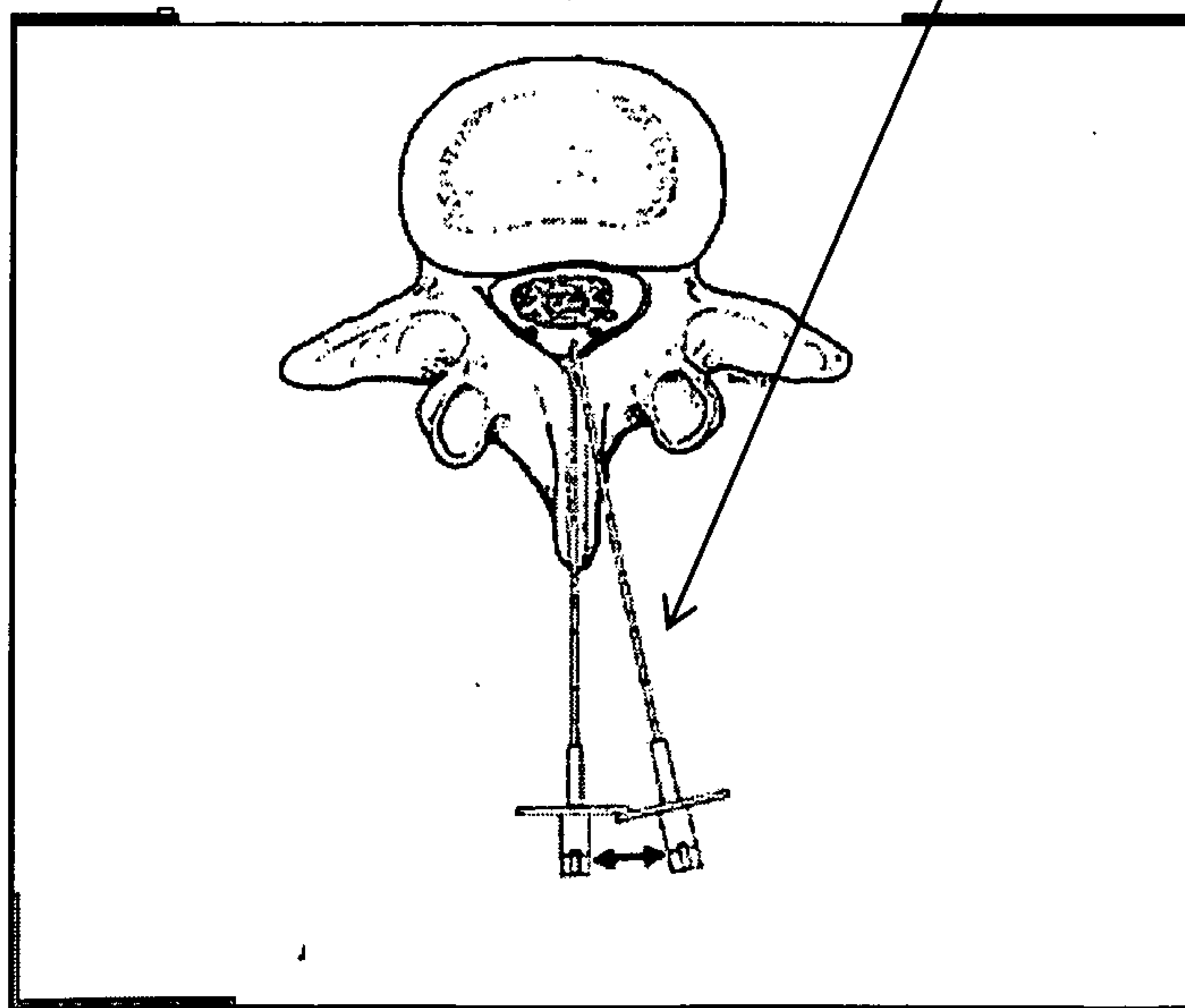

FIGURE 4

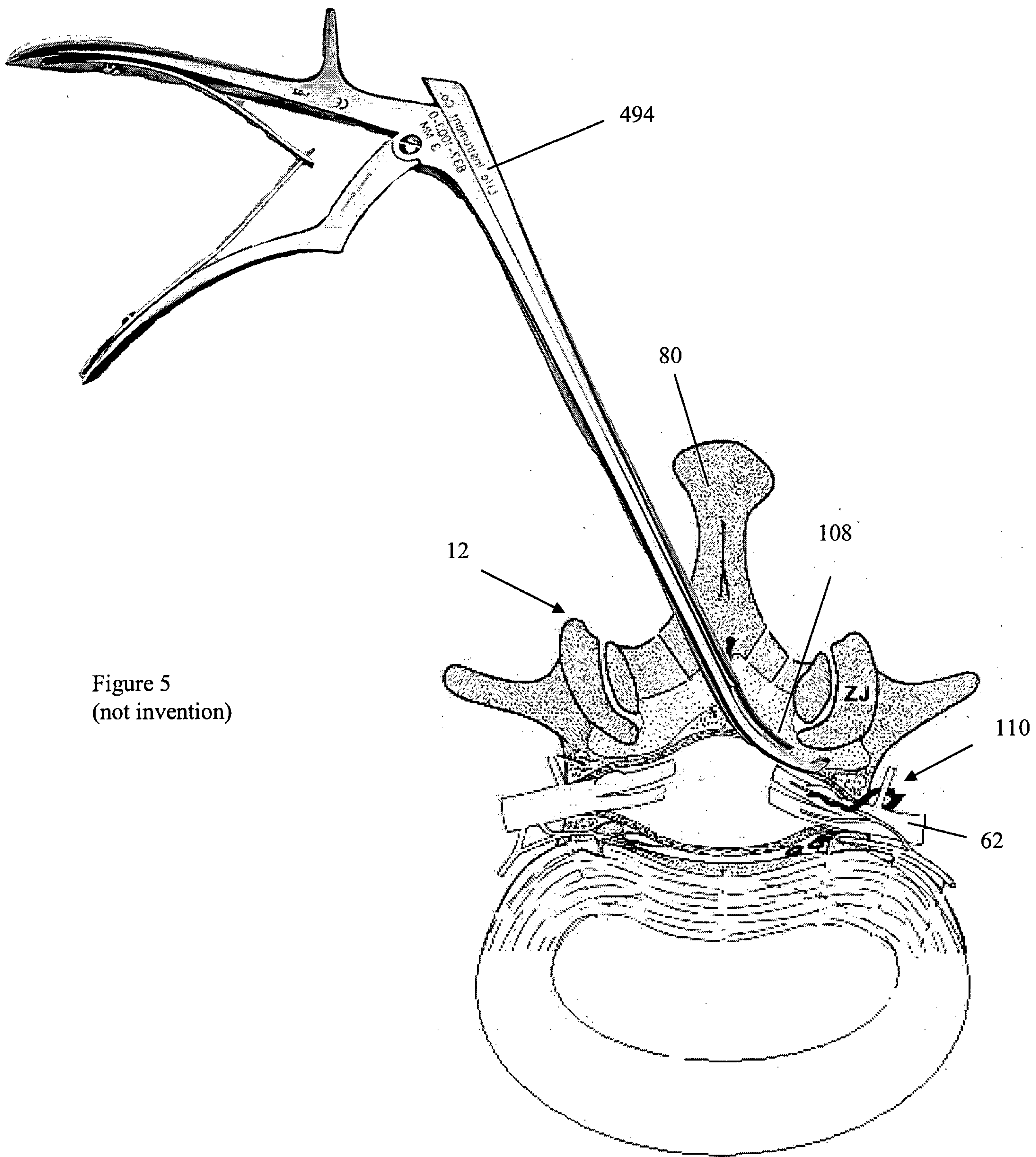

Figure 5  
(not invention)



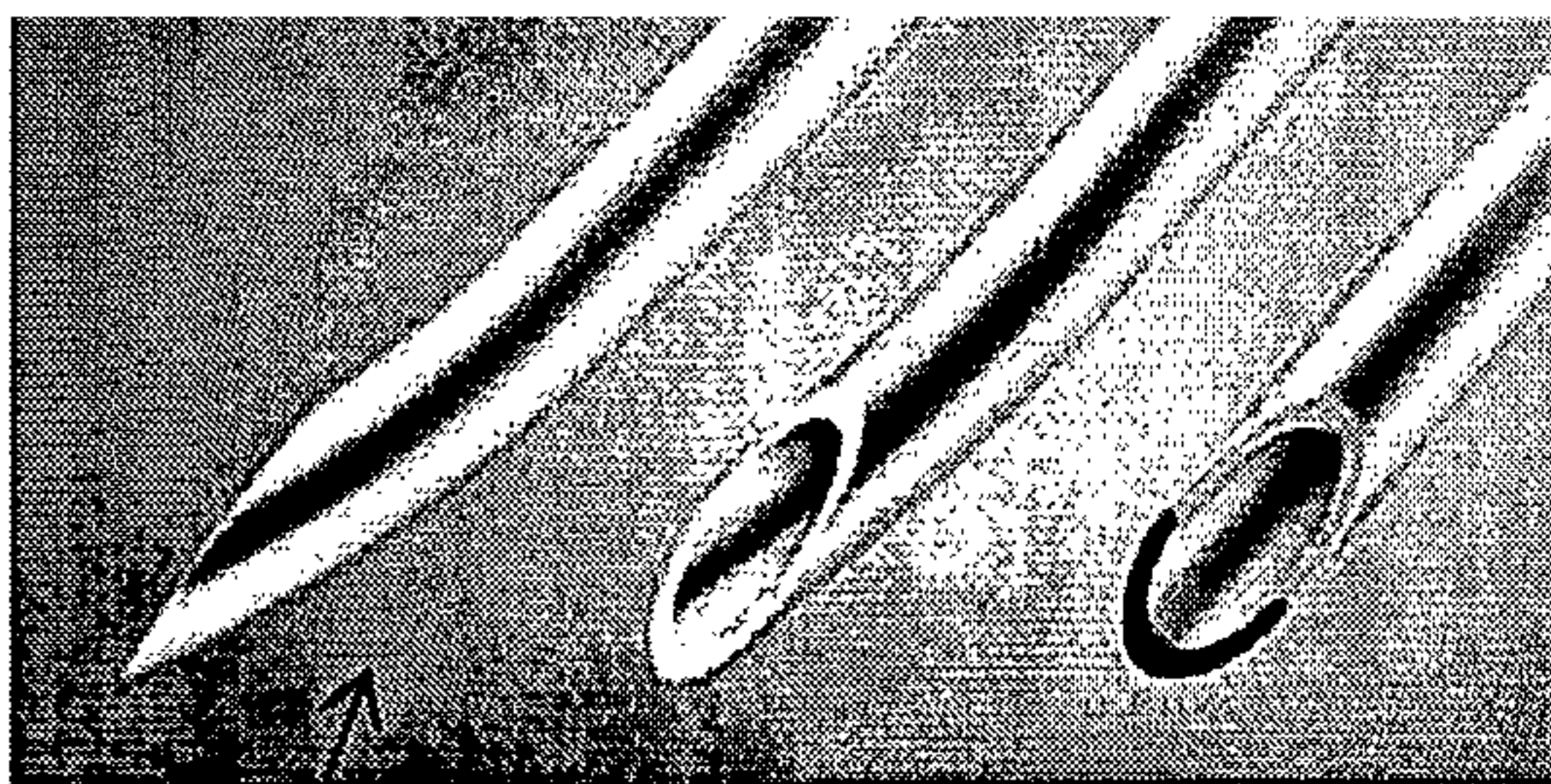

FIGURE 6

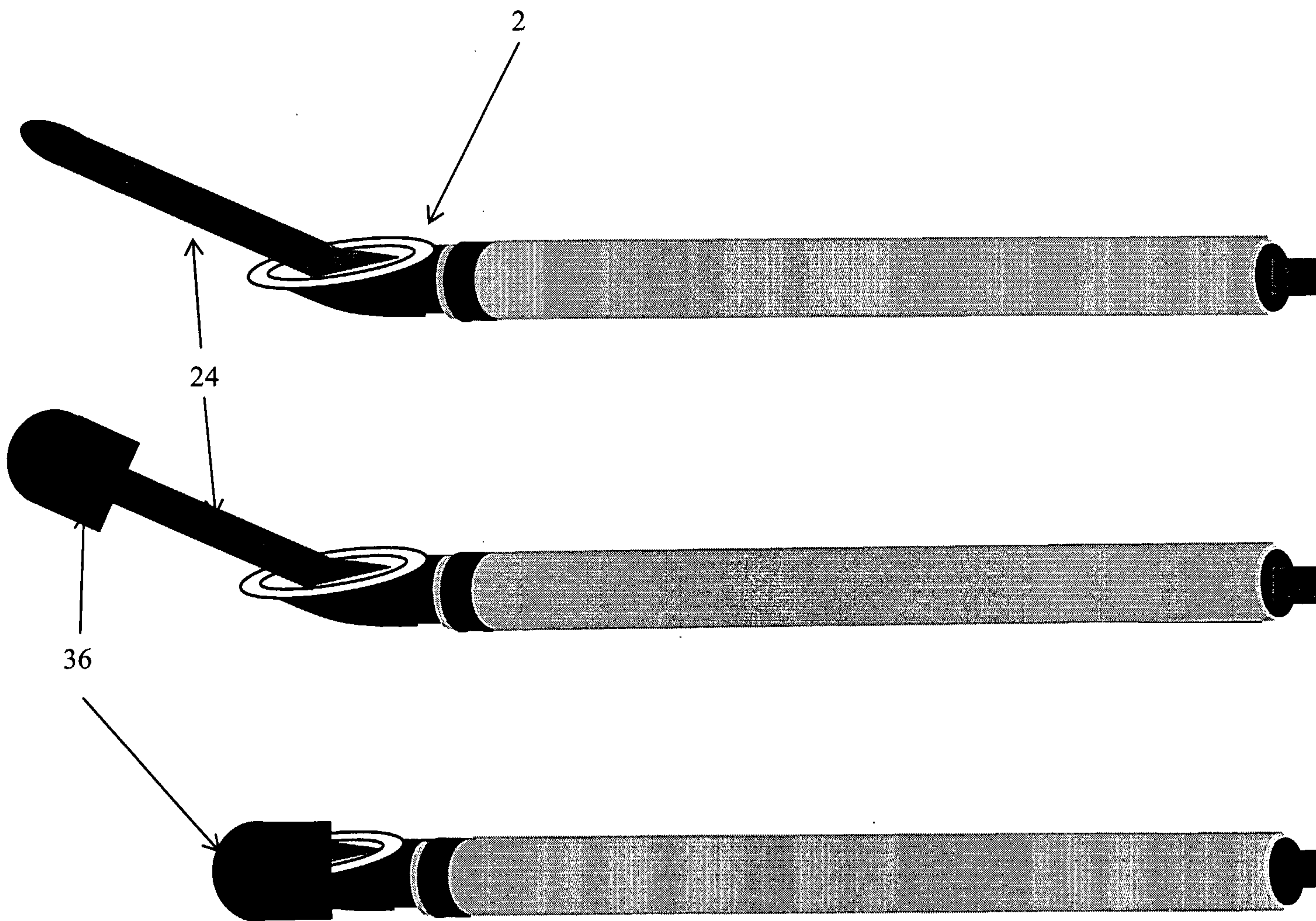

FIGURE 7 a, b, c



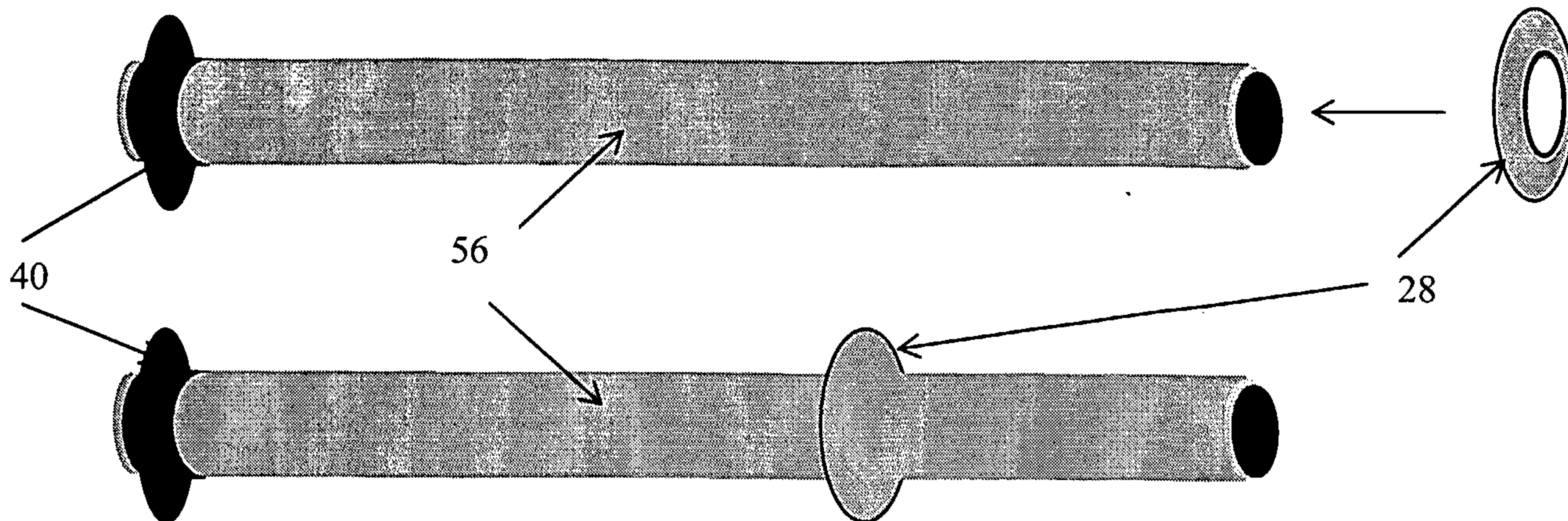

FIGURE 8 a,b,

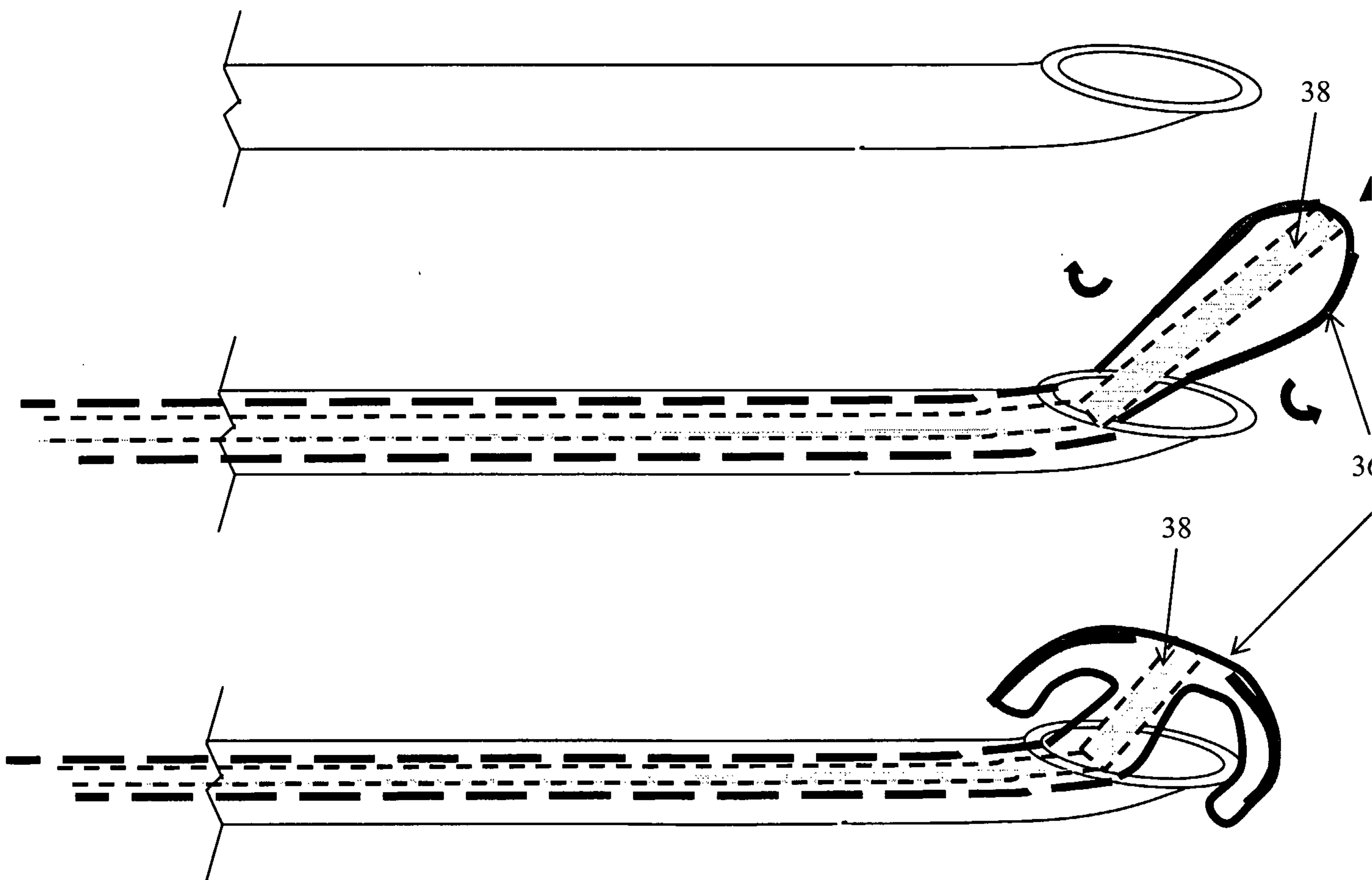

FIGURE 9 a, b, c

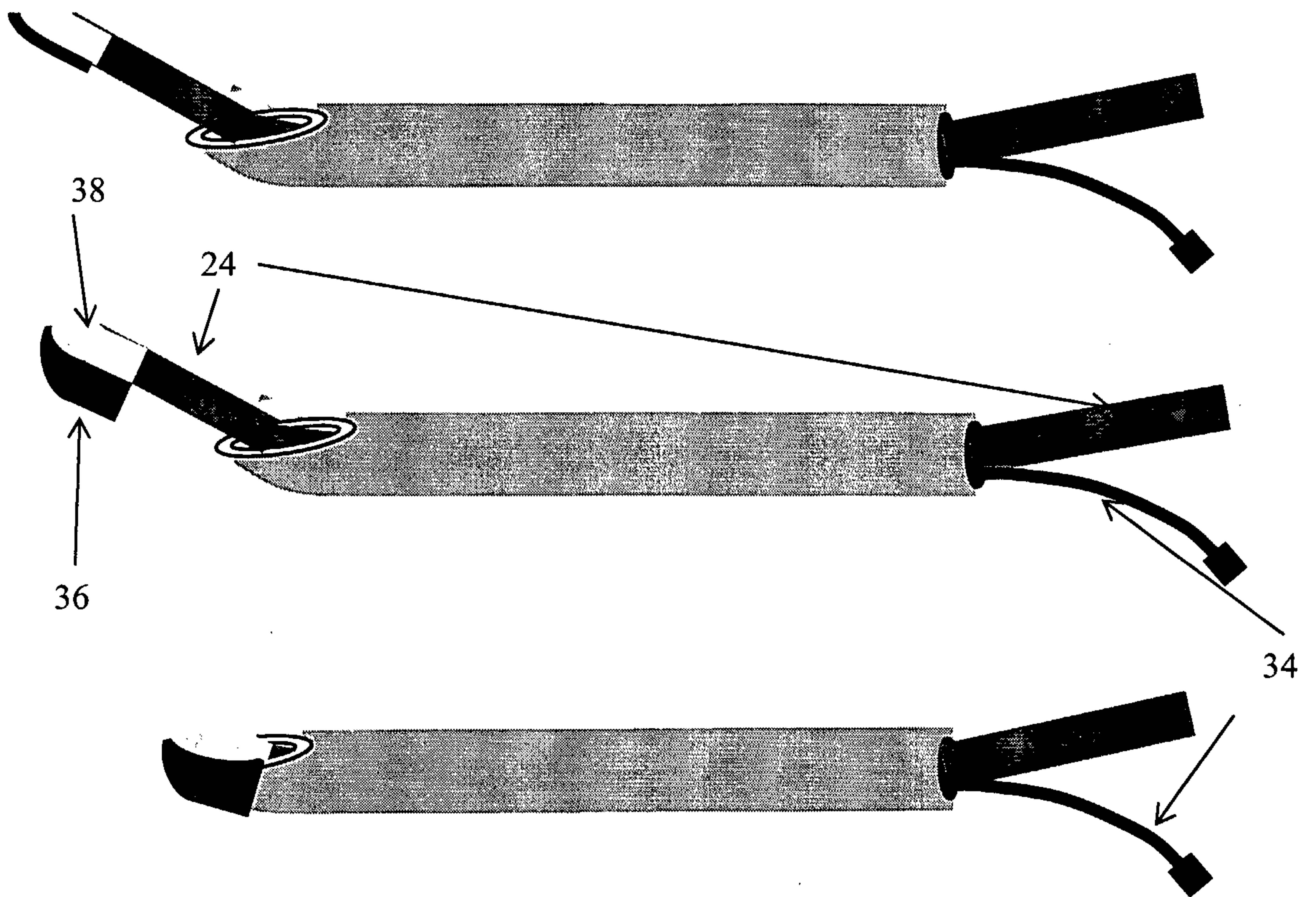

FIGURE 10 a, b, c



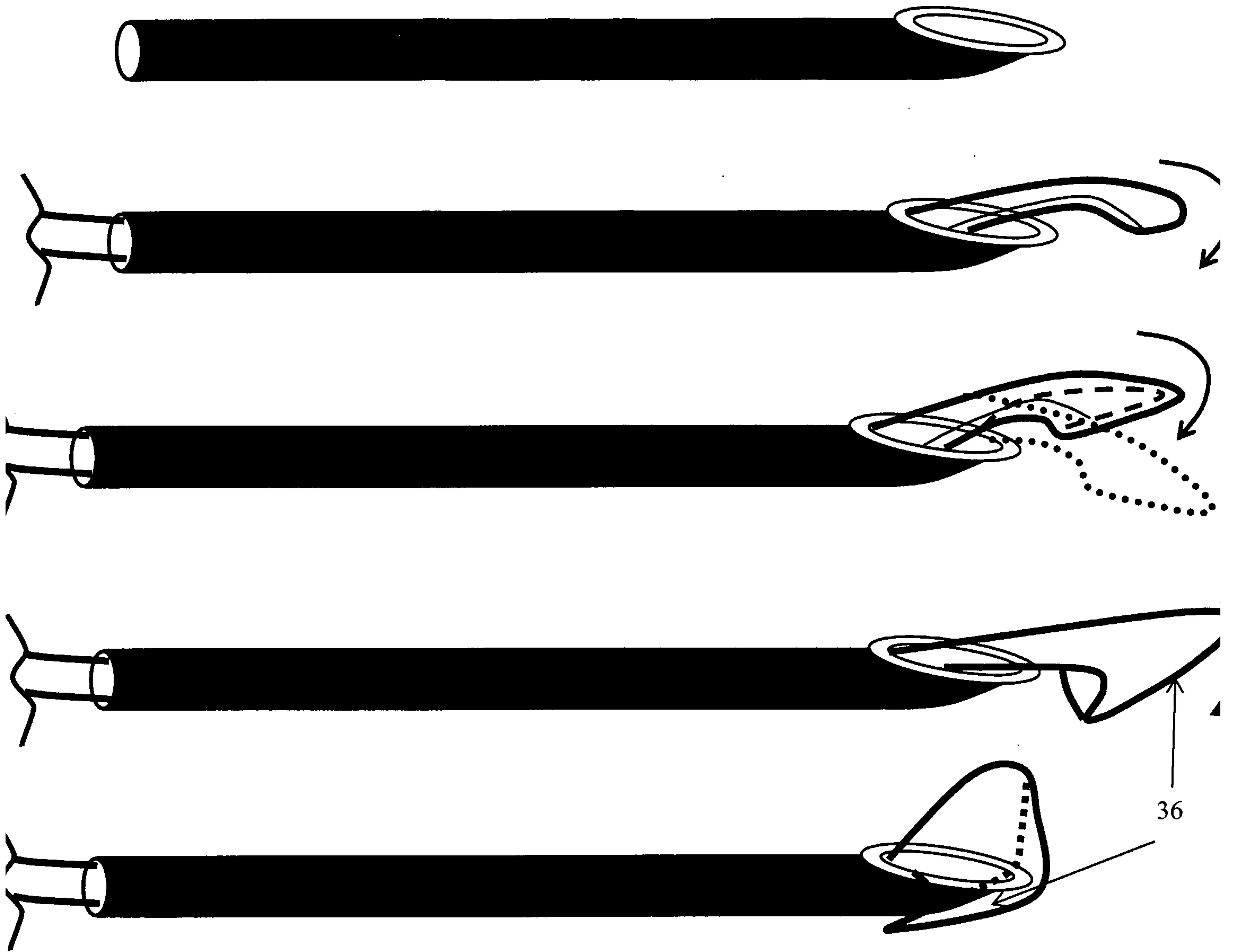

FIGURE 11 a, b, c, d, e

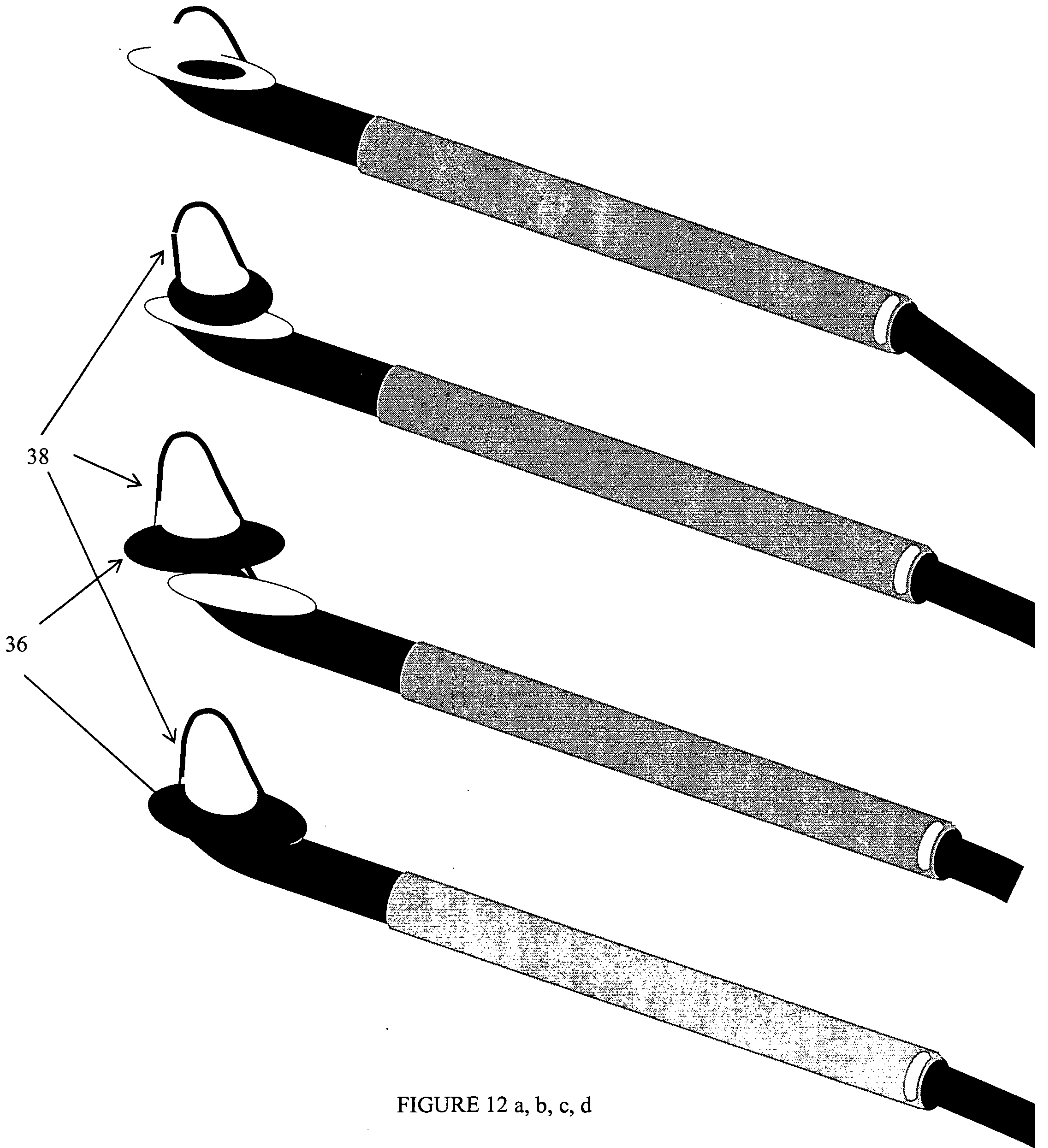

FIGURE 12 a, b, c, d



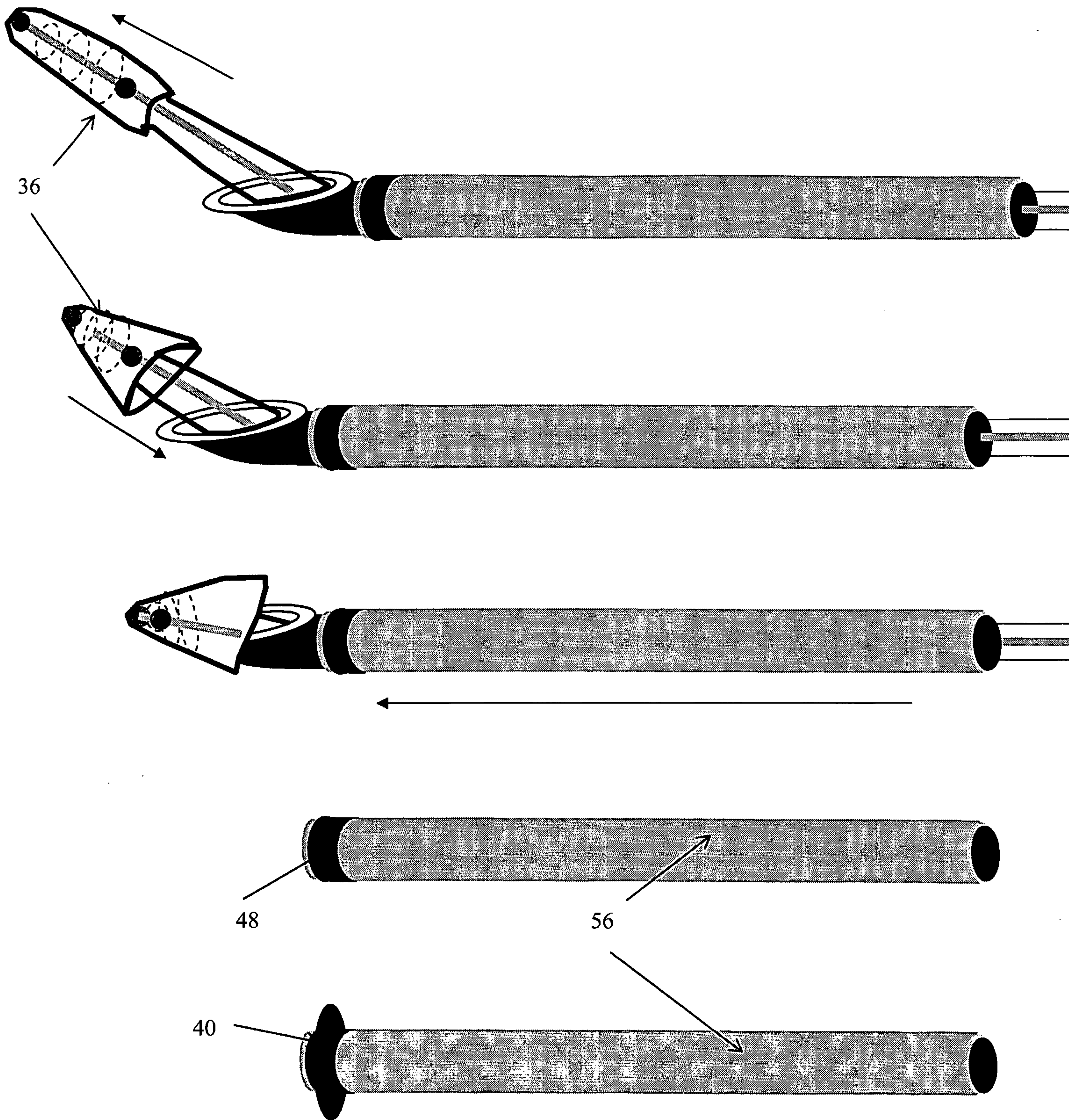

FIGURE 13 a, b, c, d, e



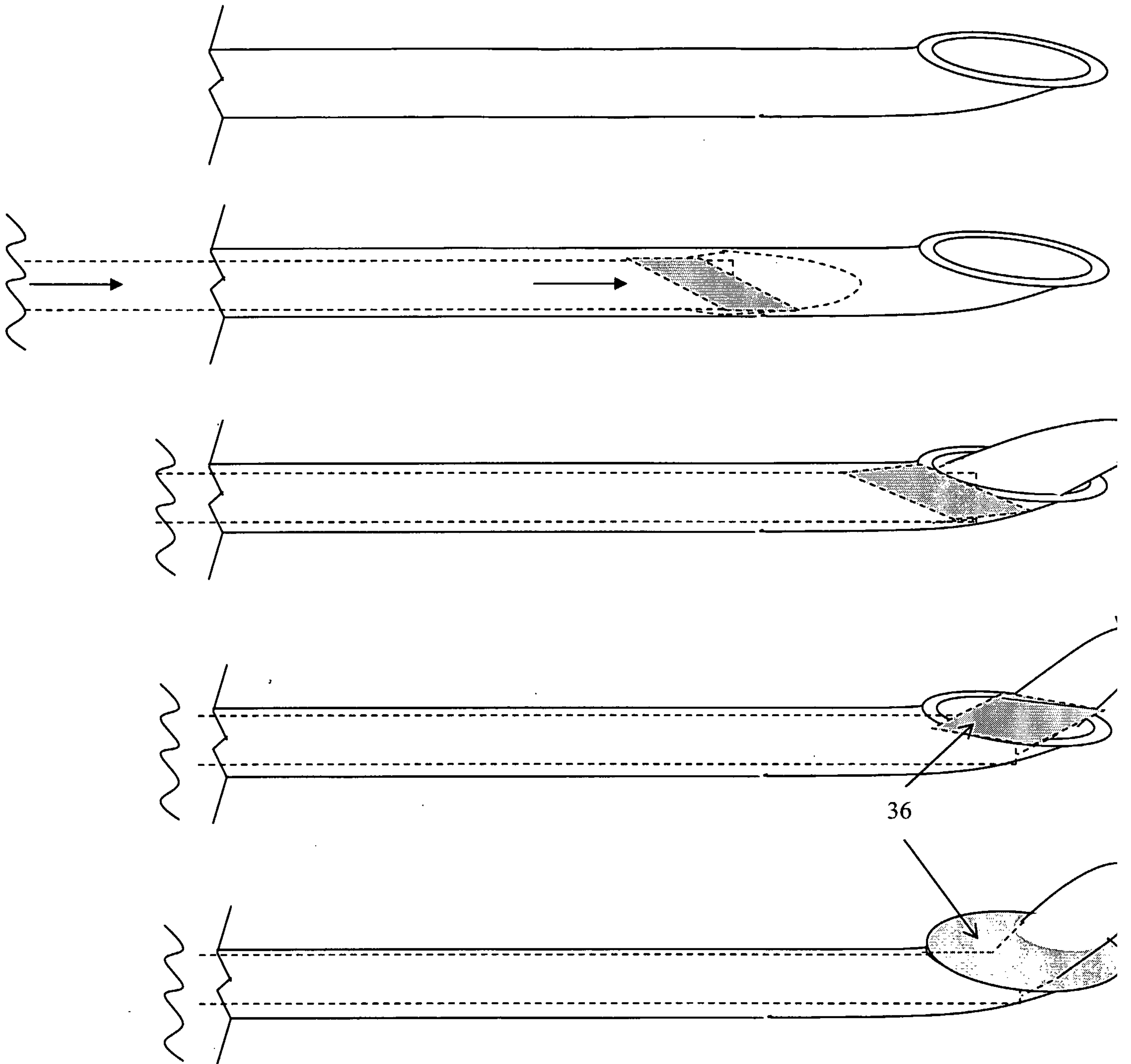
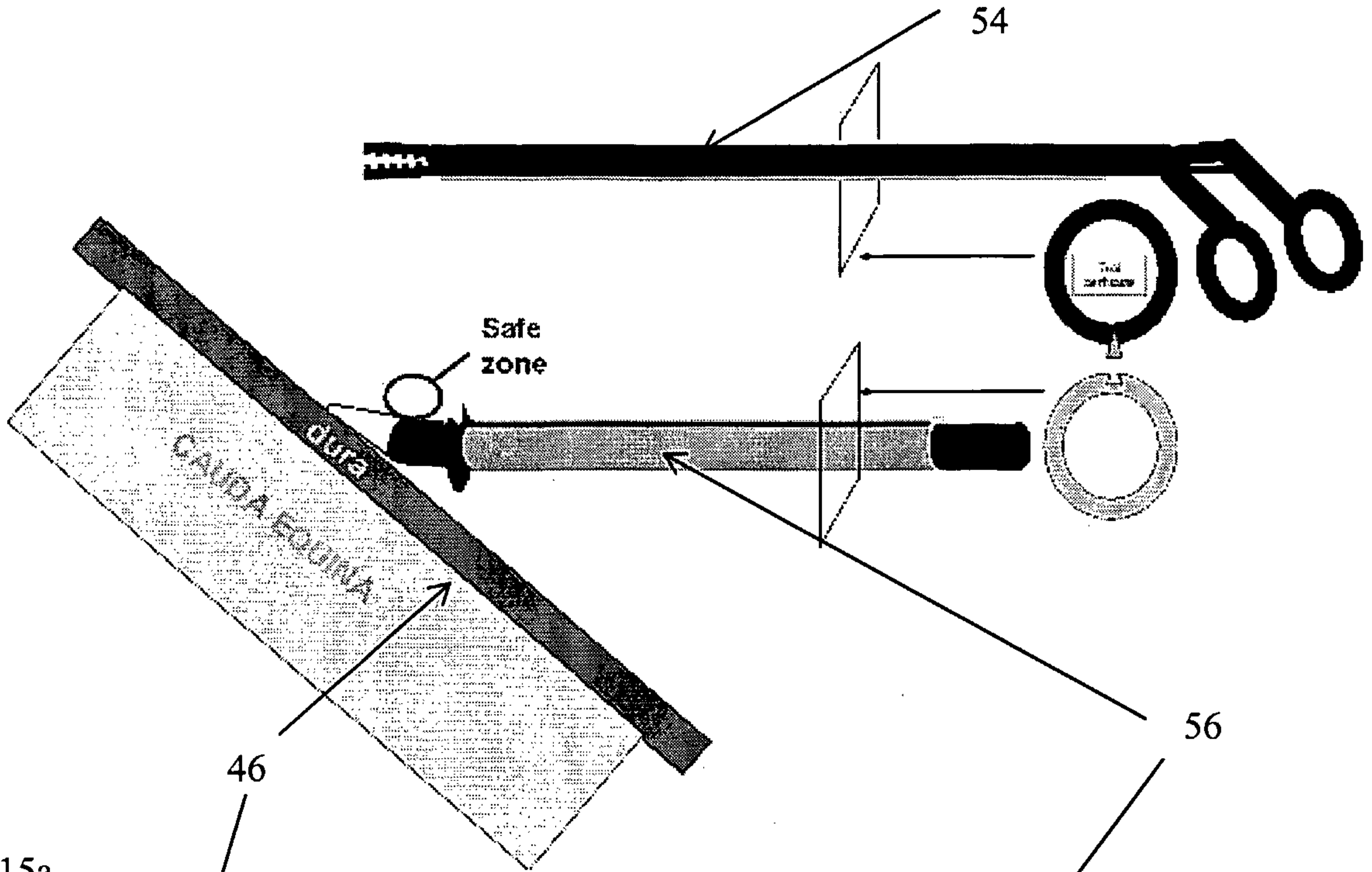

FIGURE 14 a, b, c, d, e

### Safe Tool Access



FIGURES 15a

### Safe Tool Access

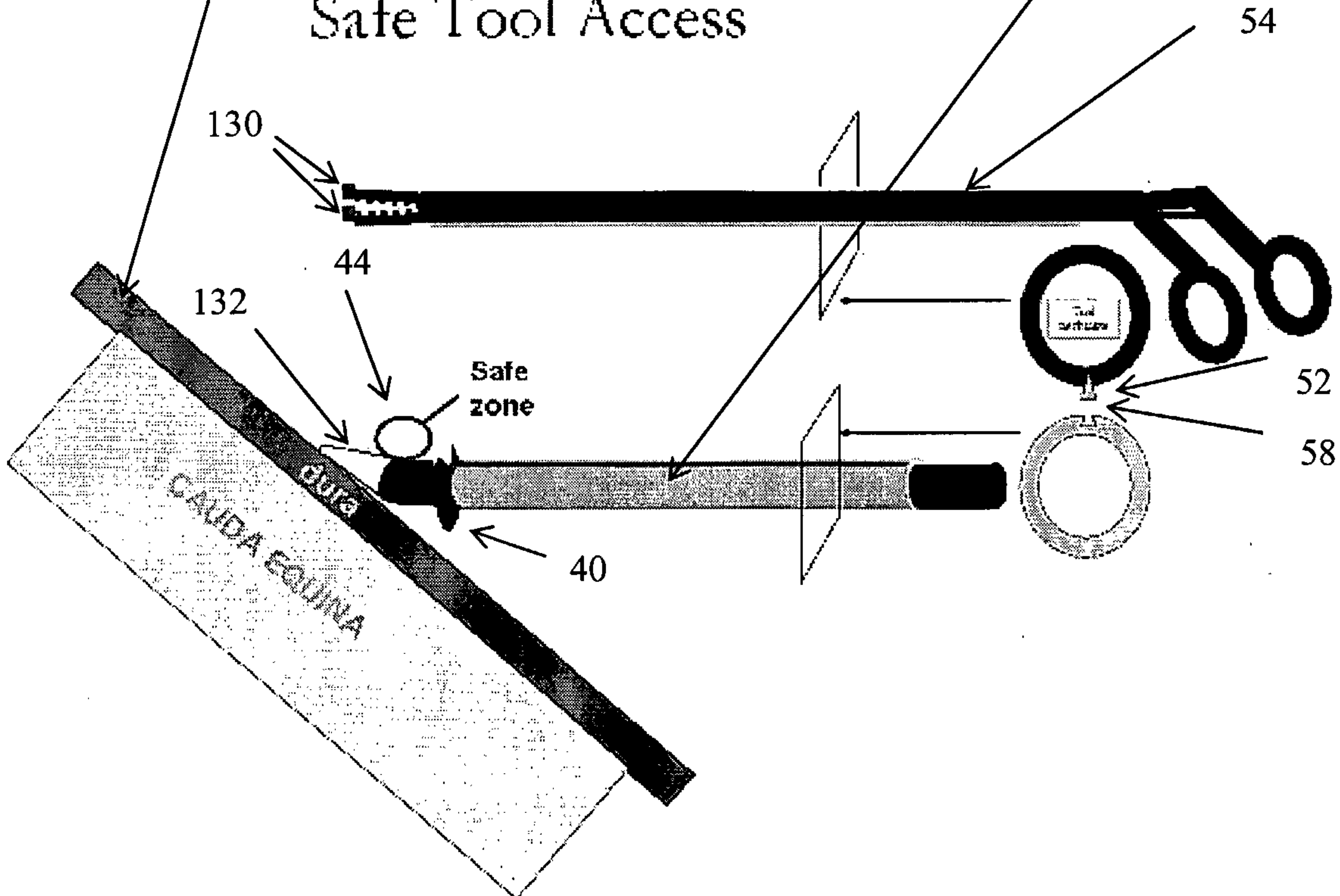
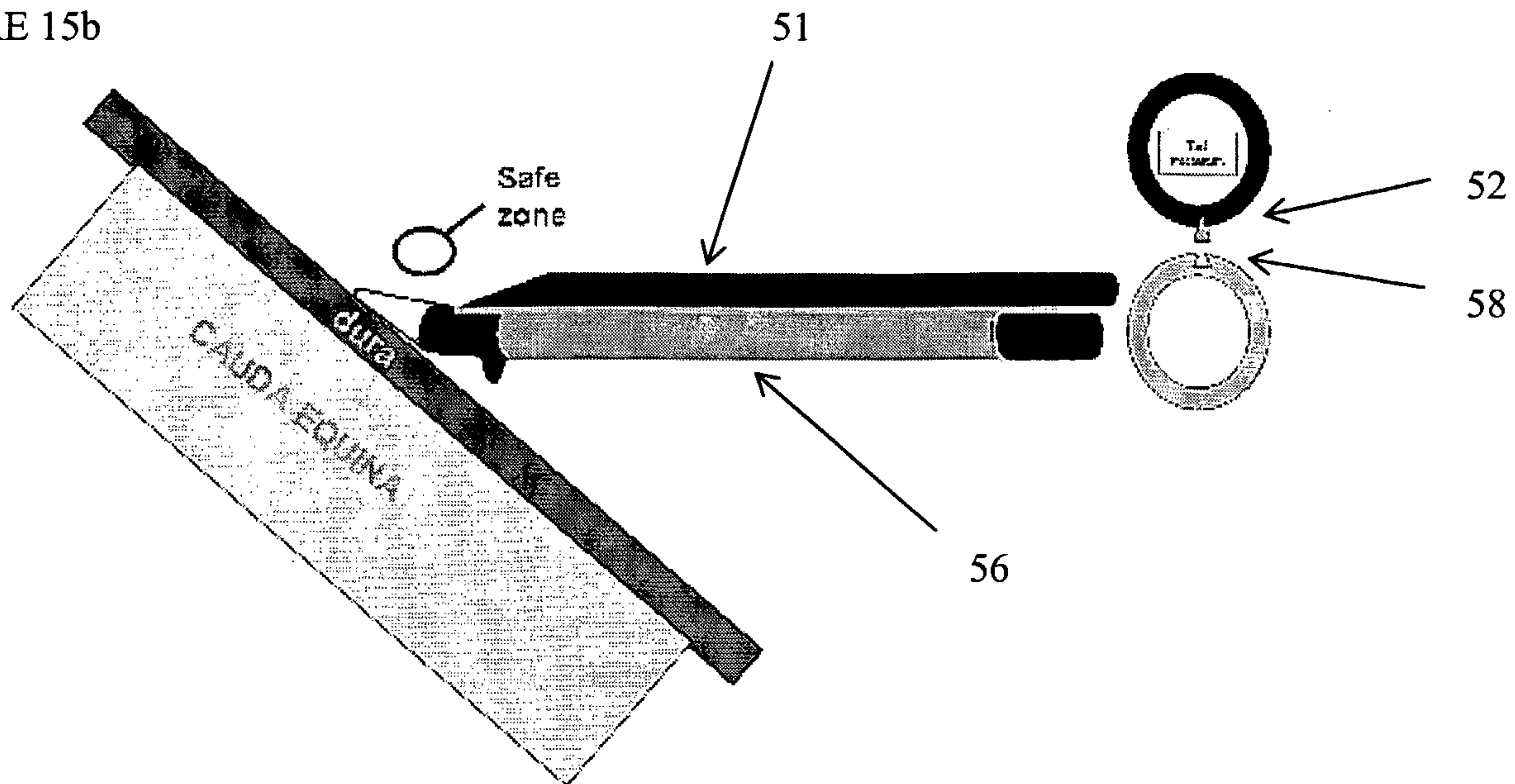

FIGURE 15b





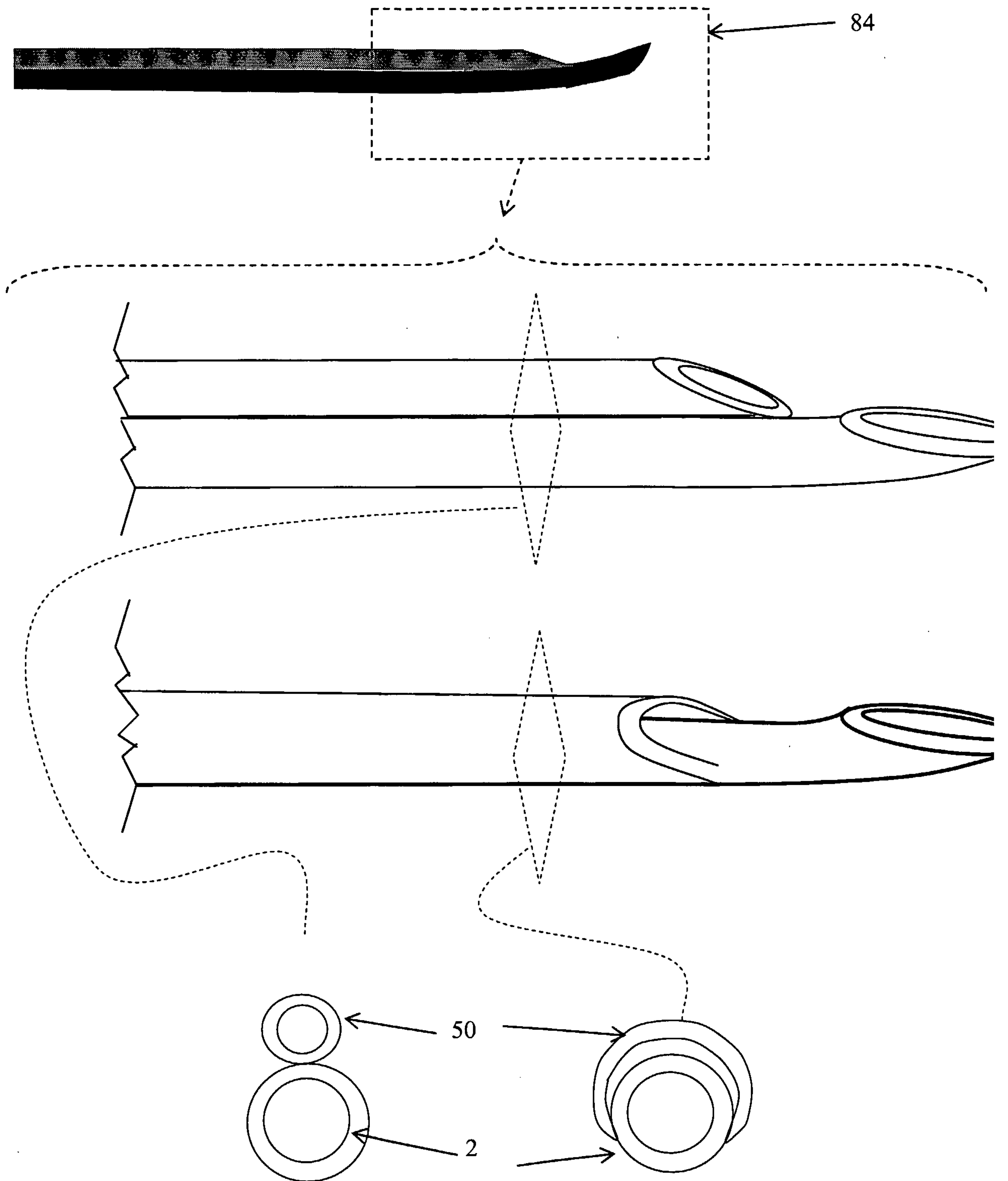

FIGURE 16

FIGURE 17

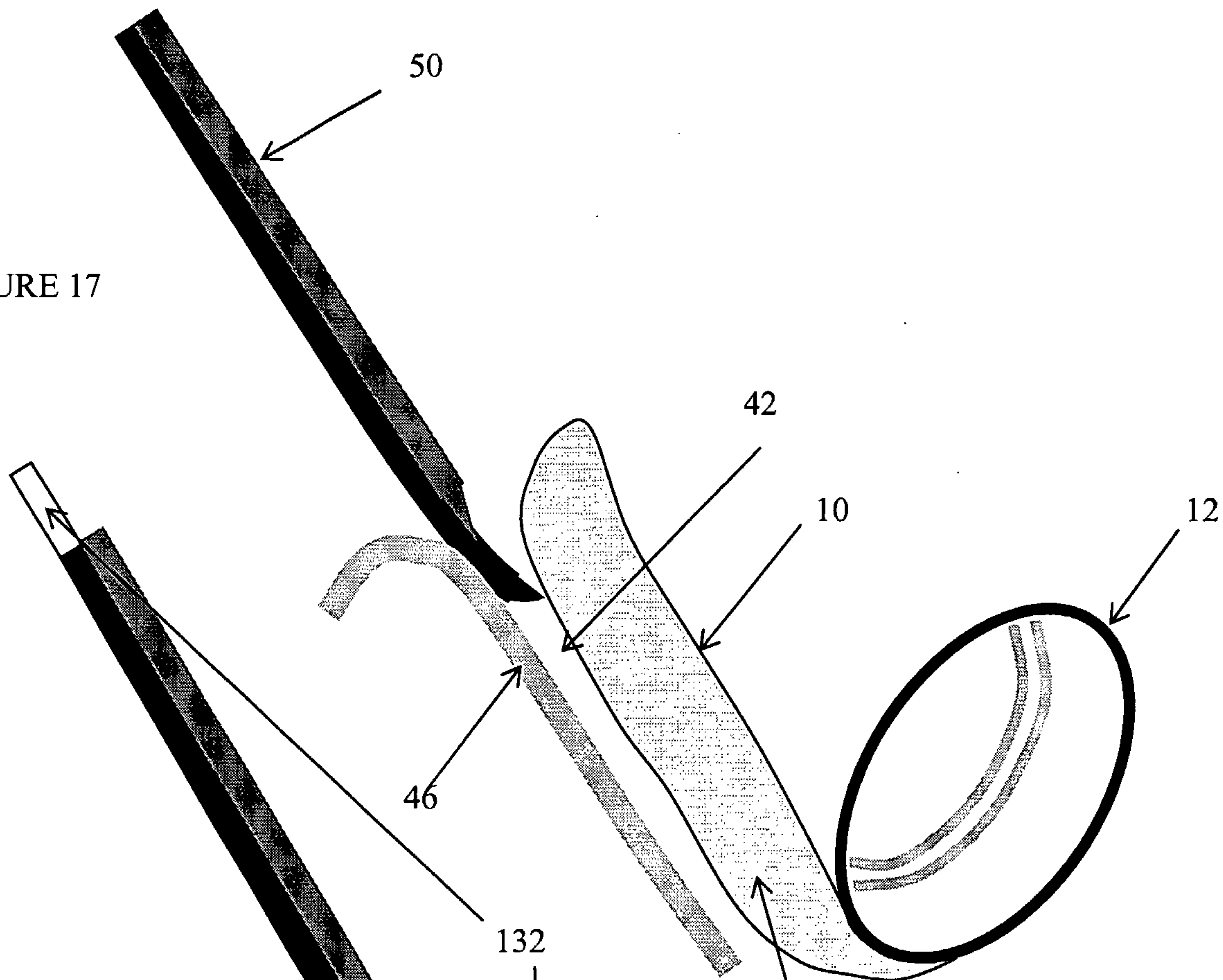
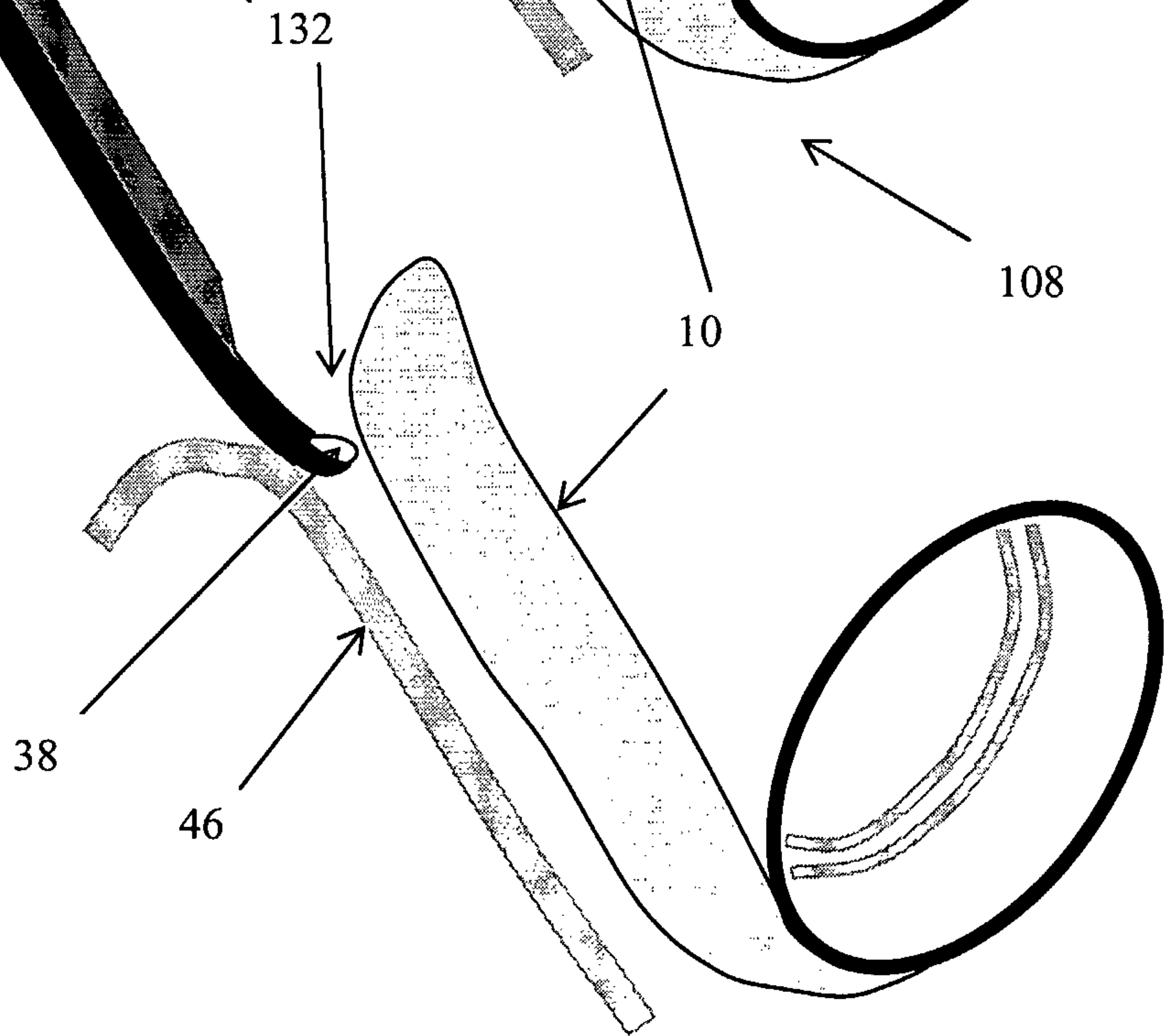
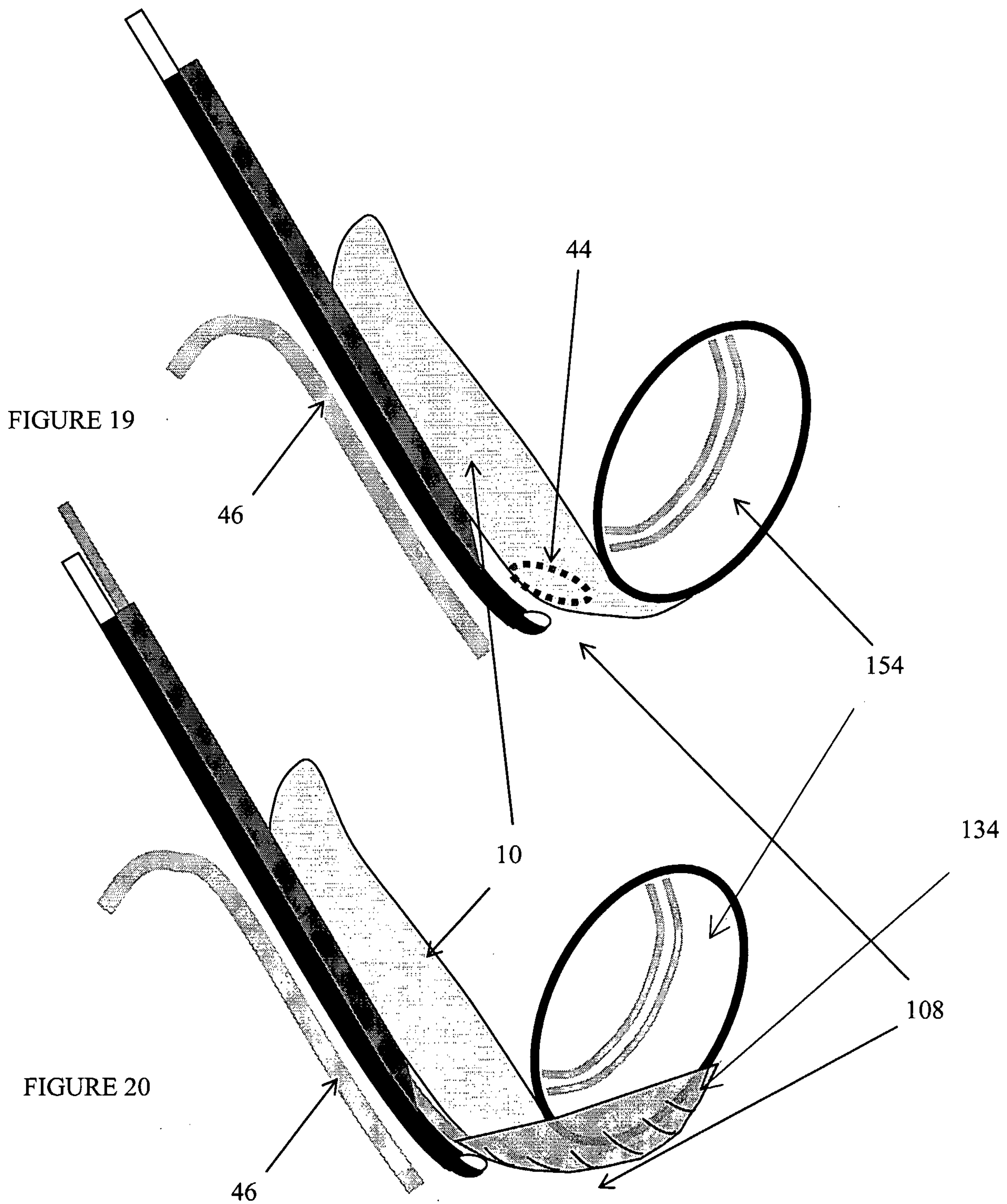

FIGURE 18







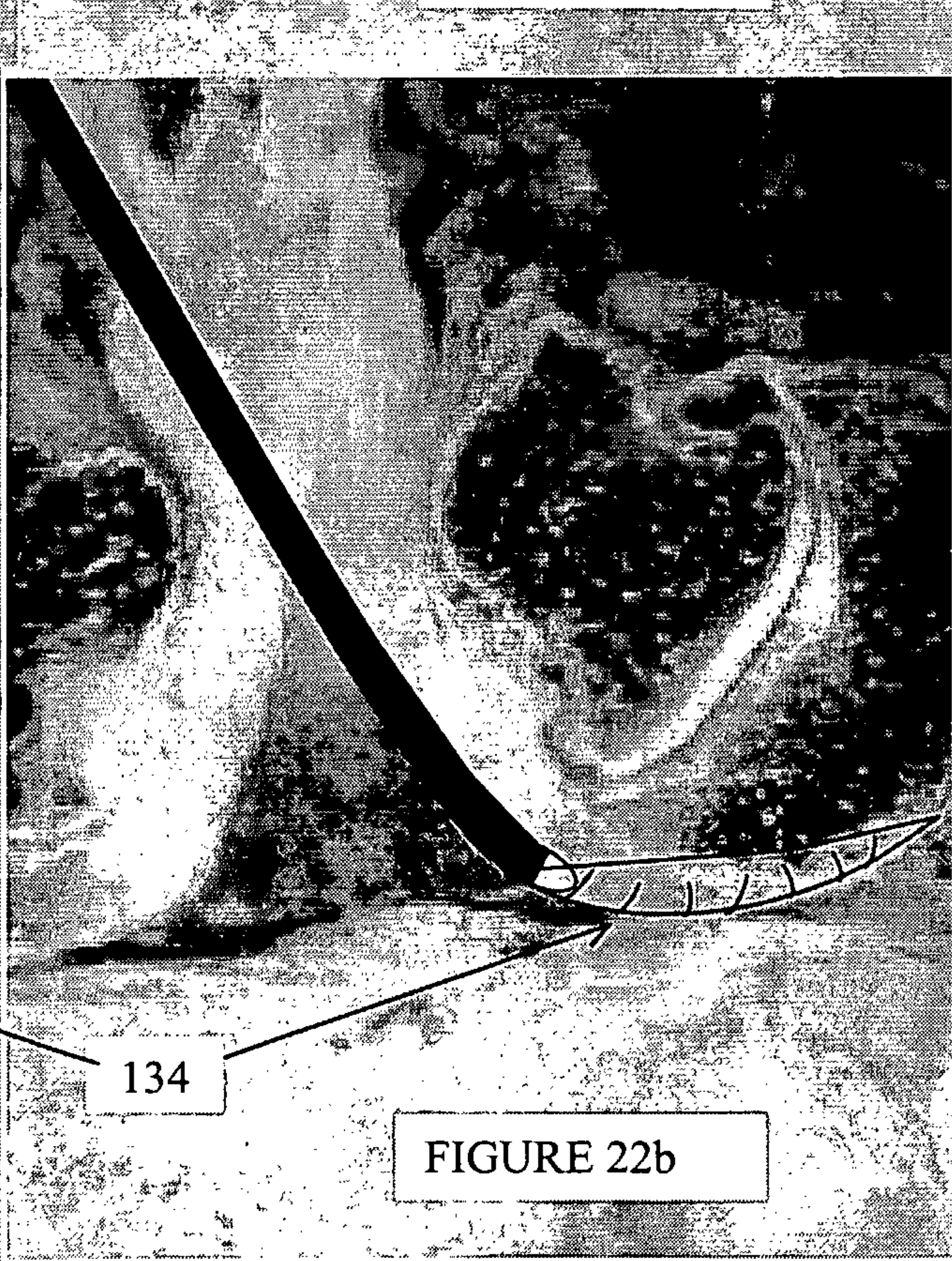
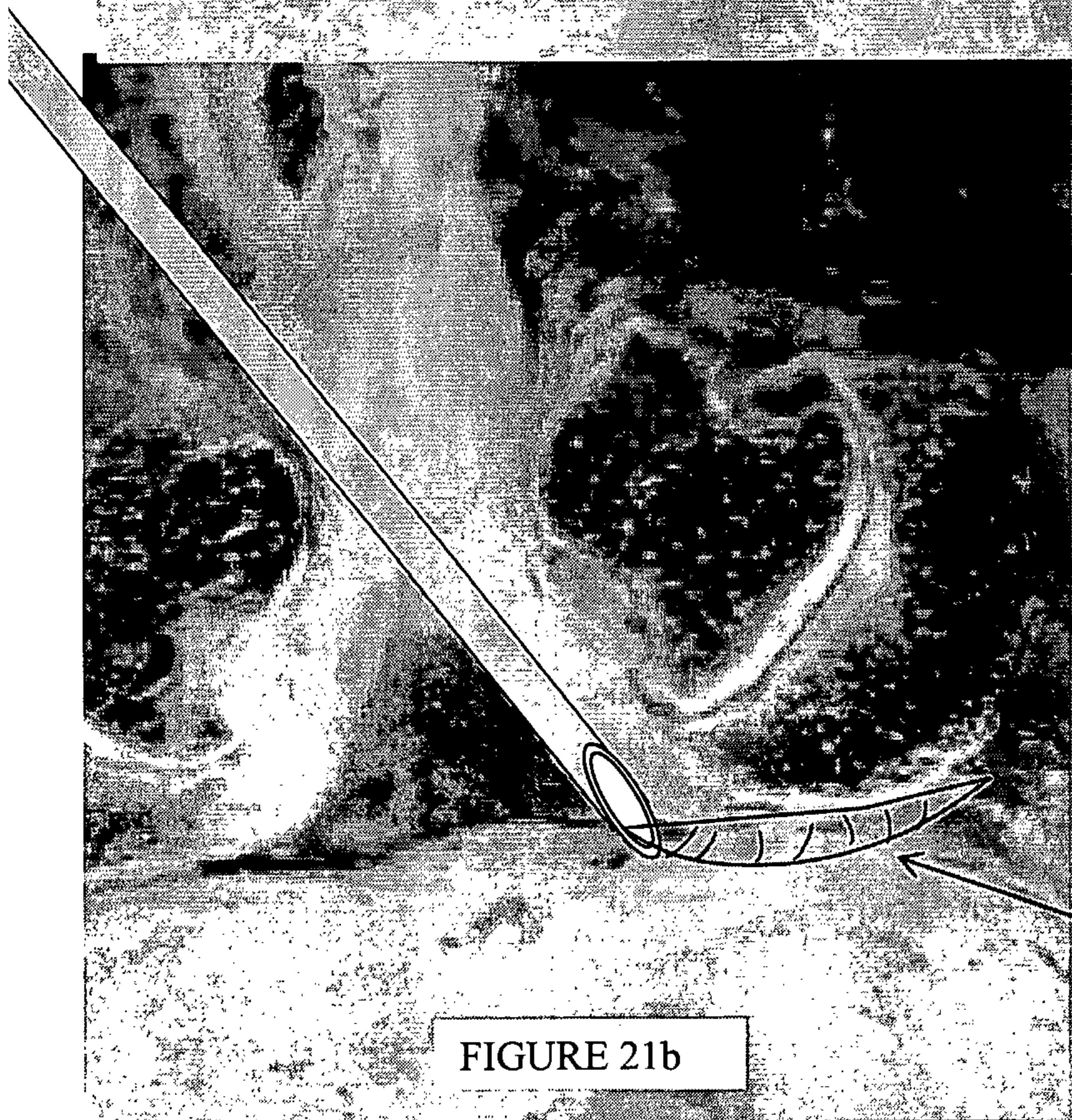
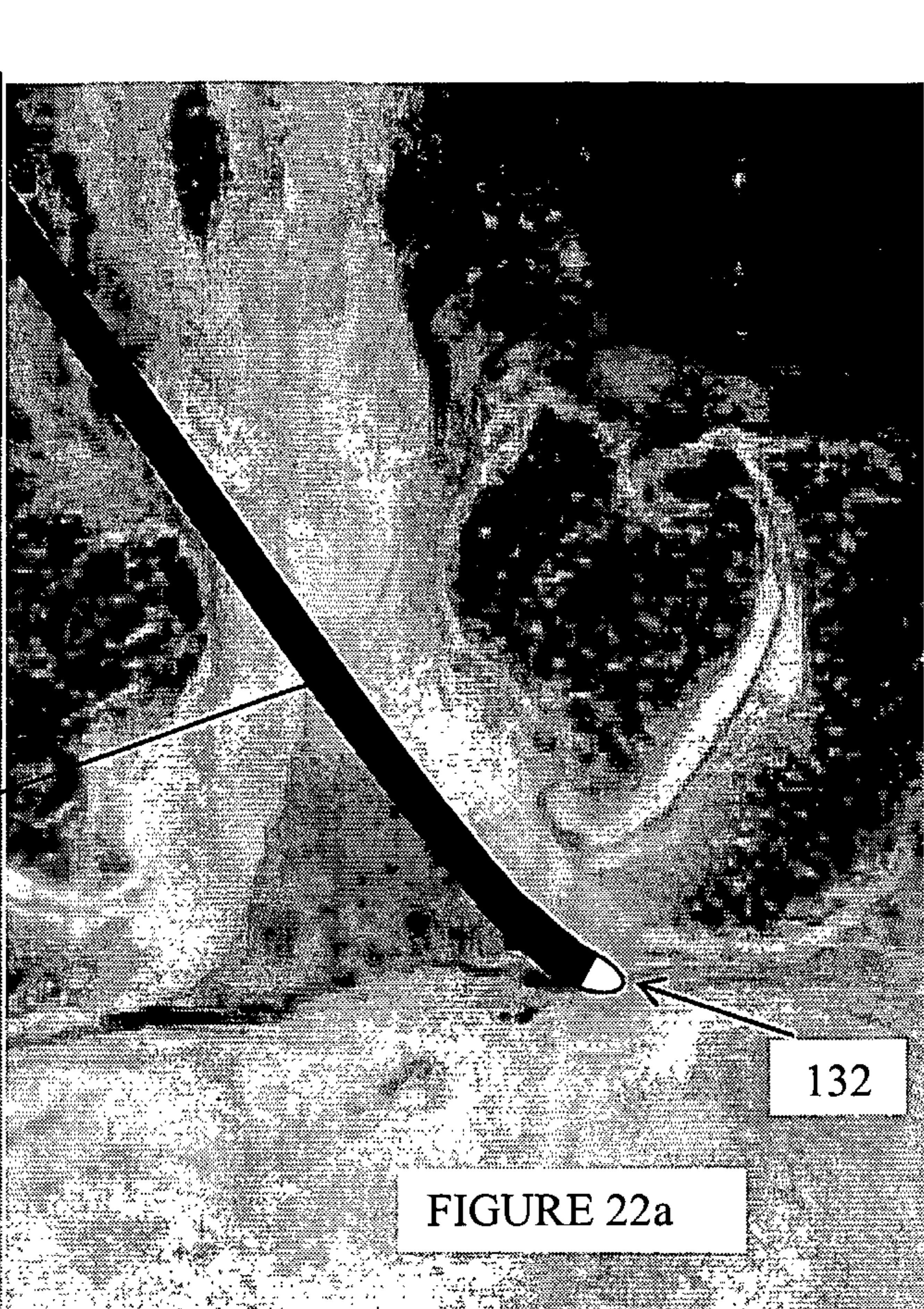
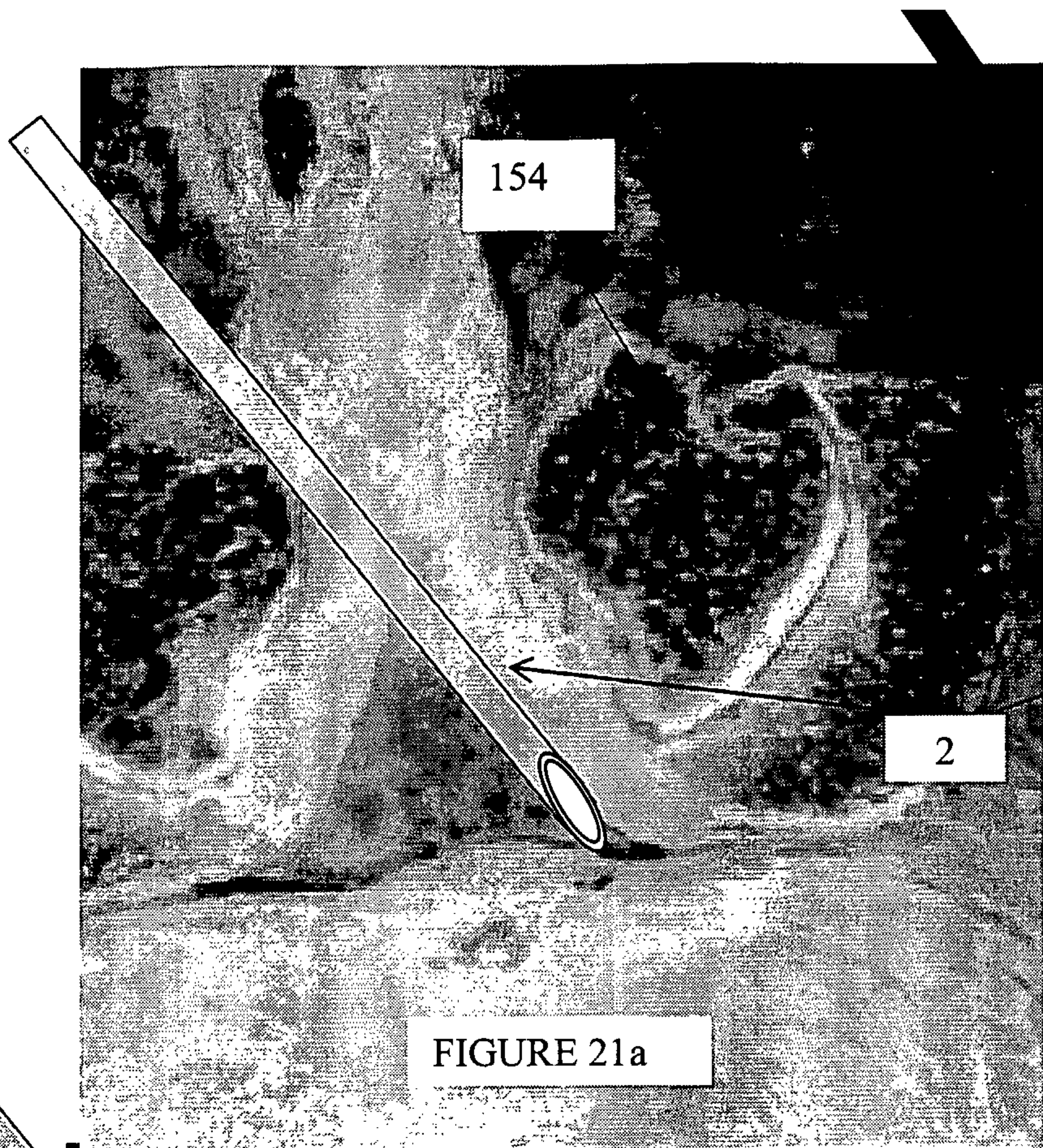





FIGURE 23

134



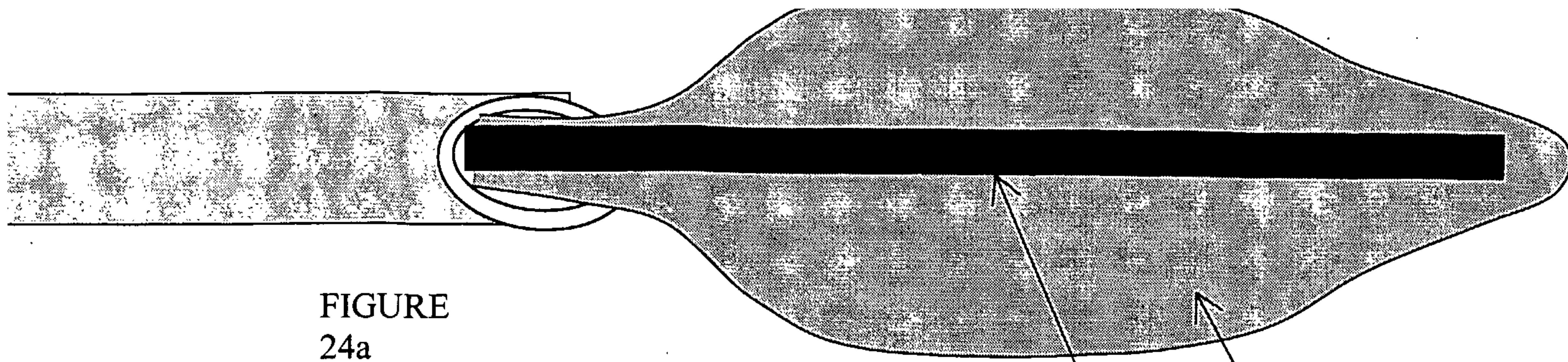

FIGURE 24a

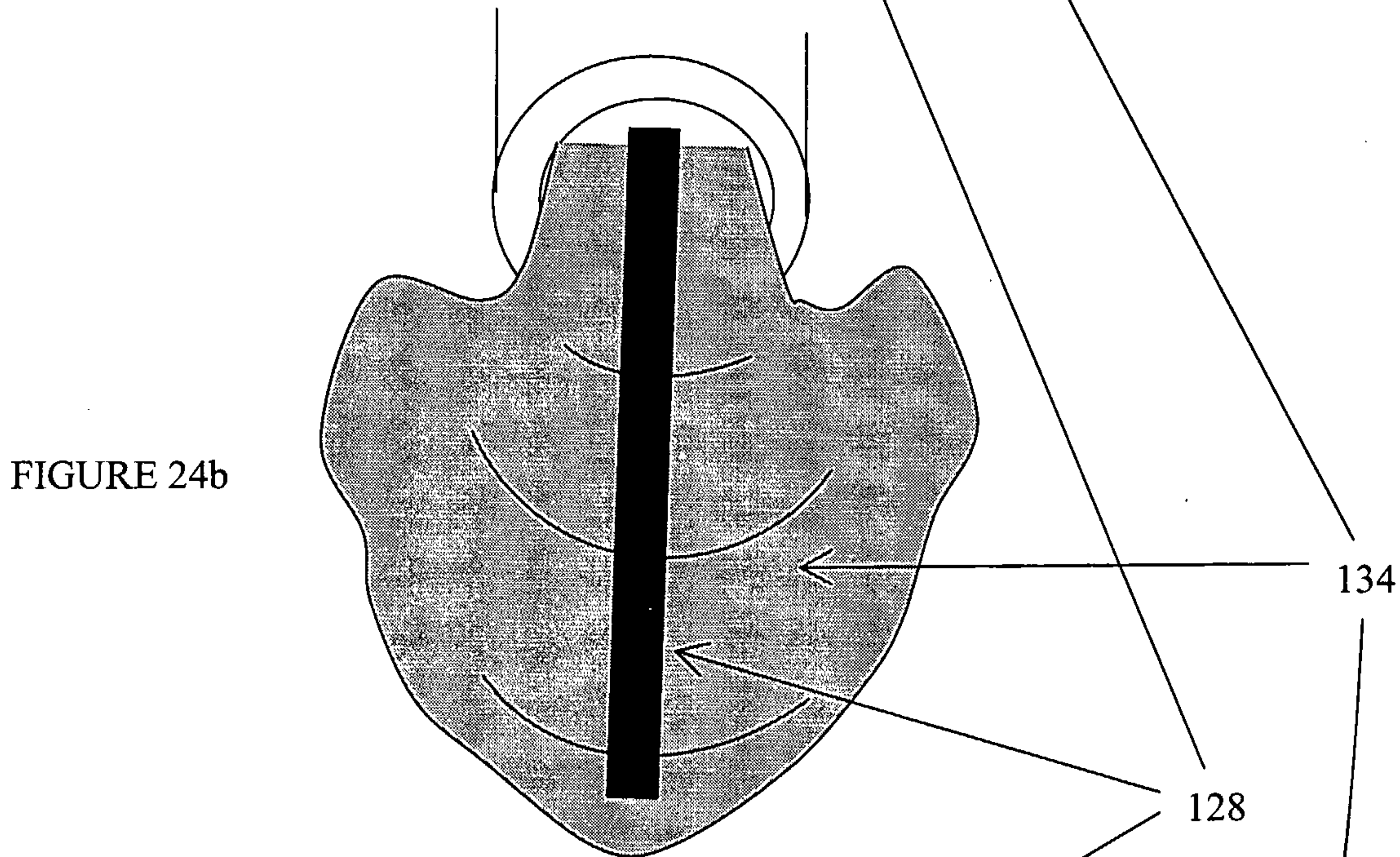

FIGURE 24b

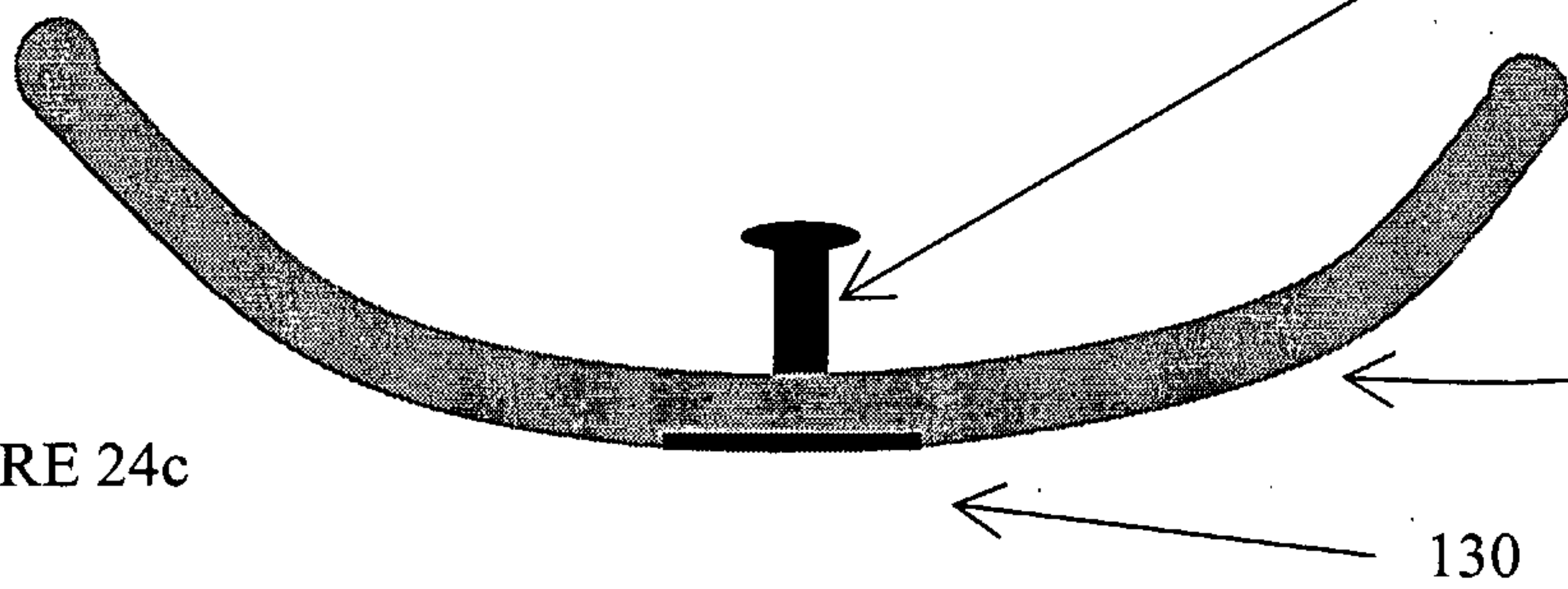

FIGURE 24c

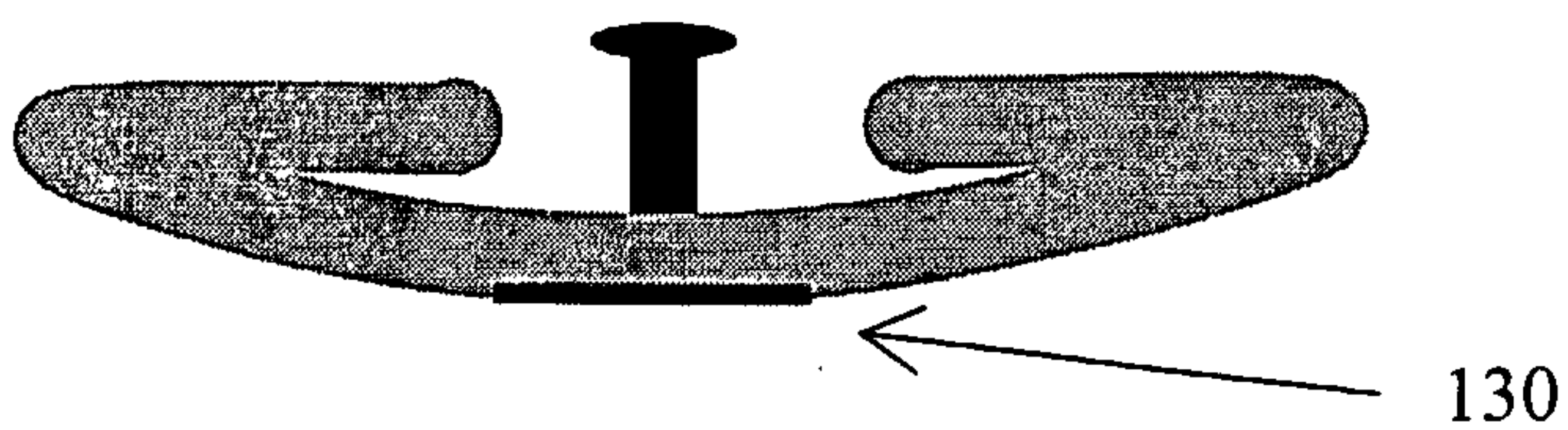

FIGURE 24d



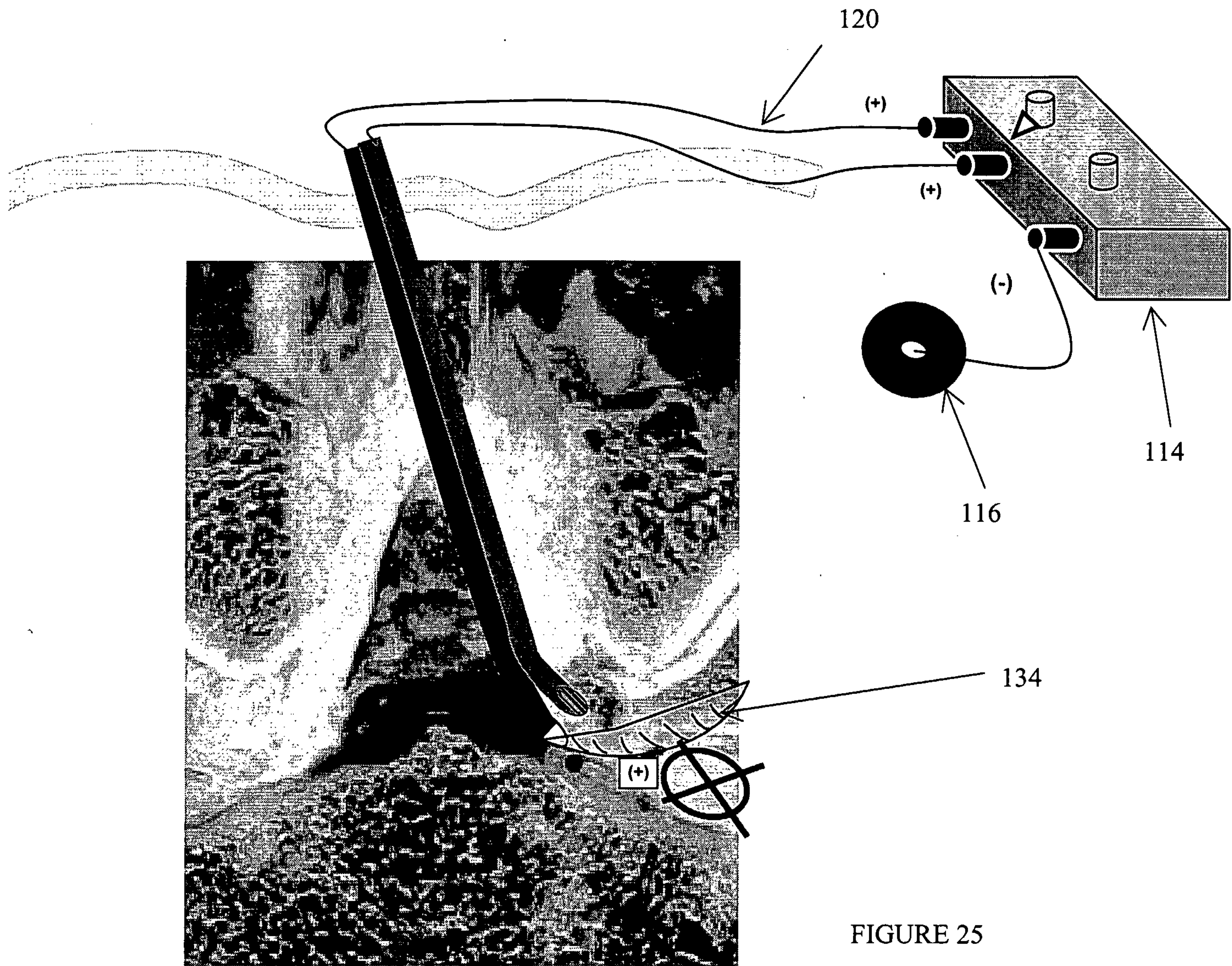
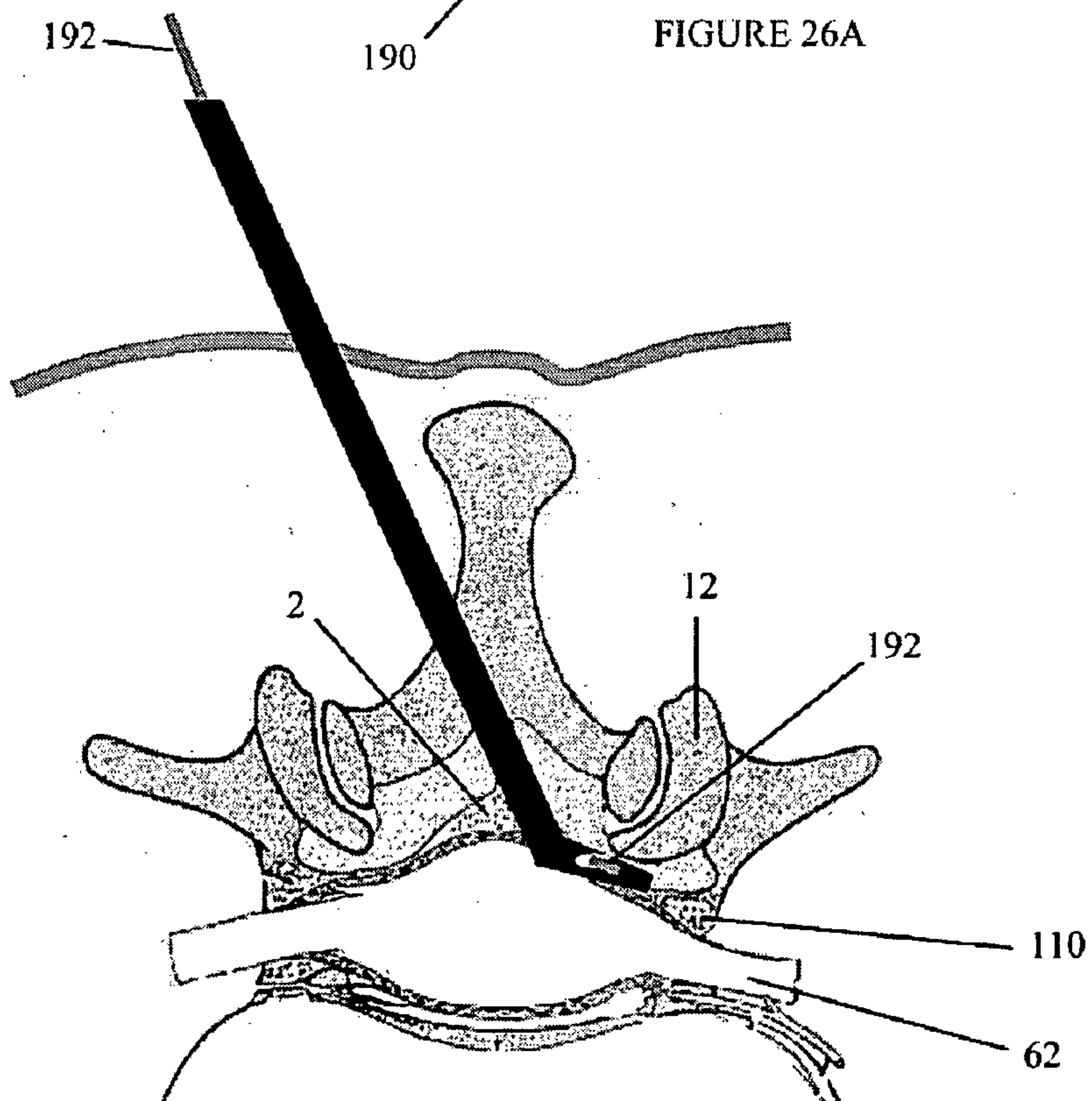
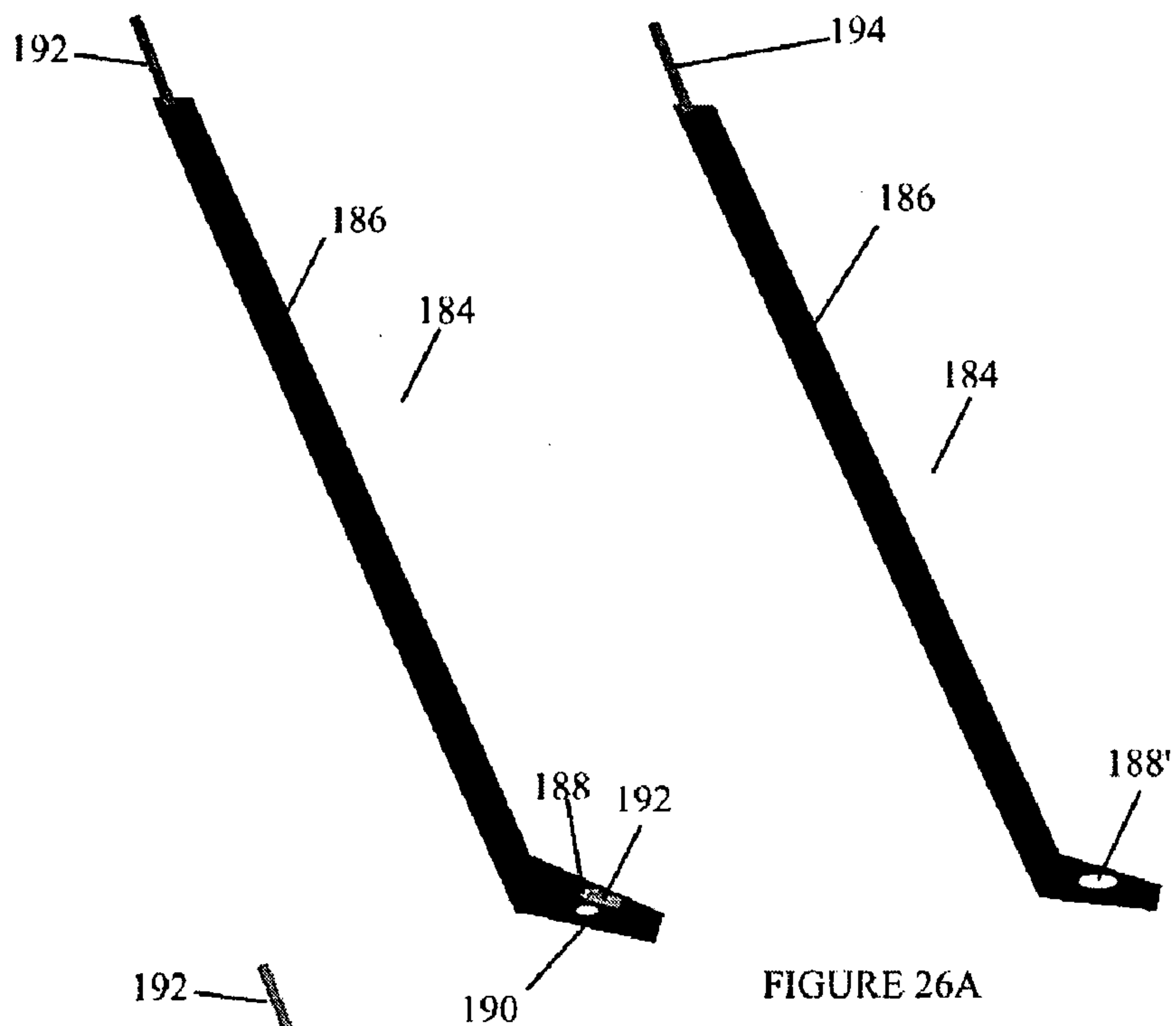
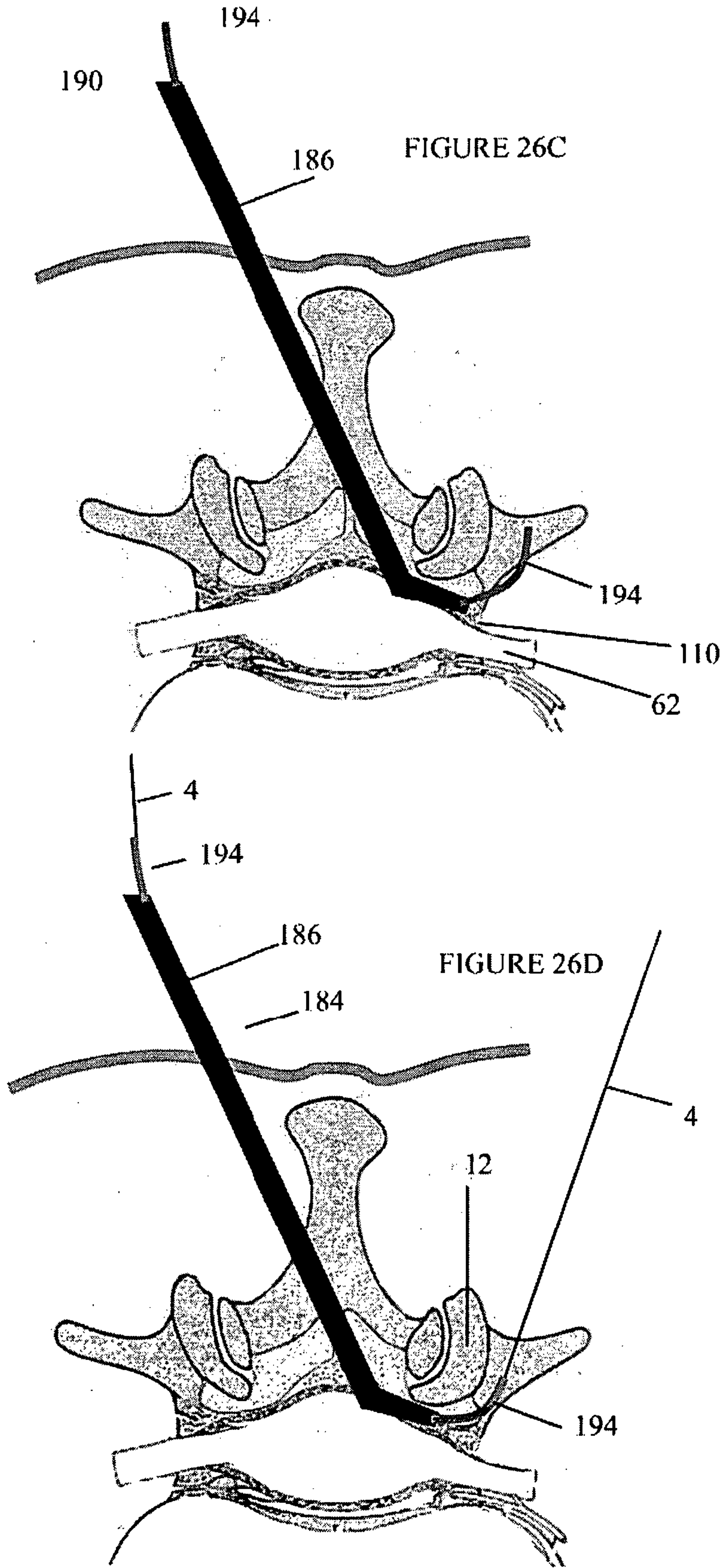

FIGURE 25









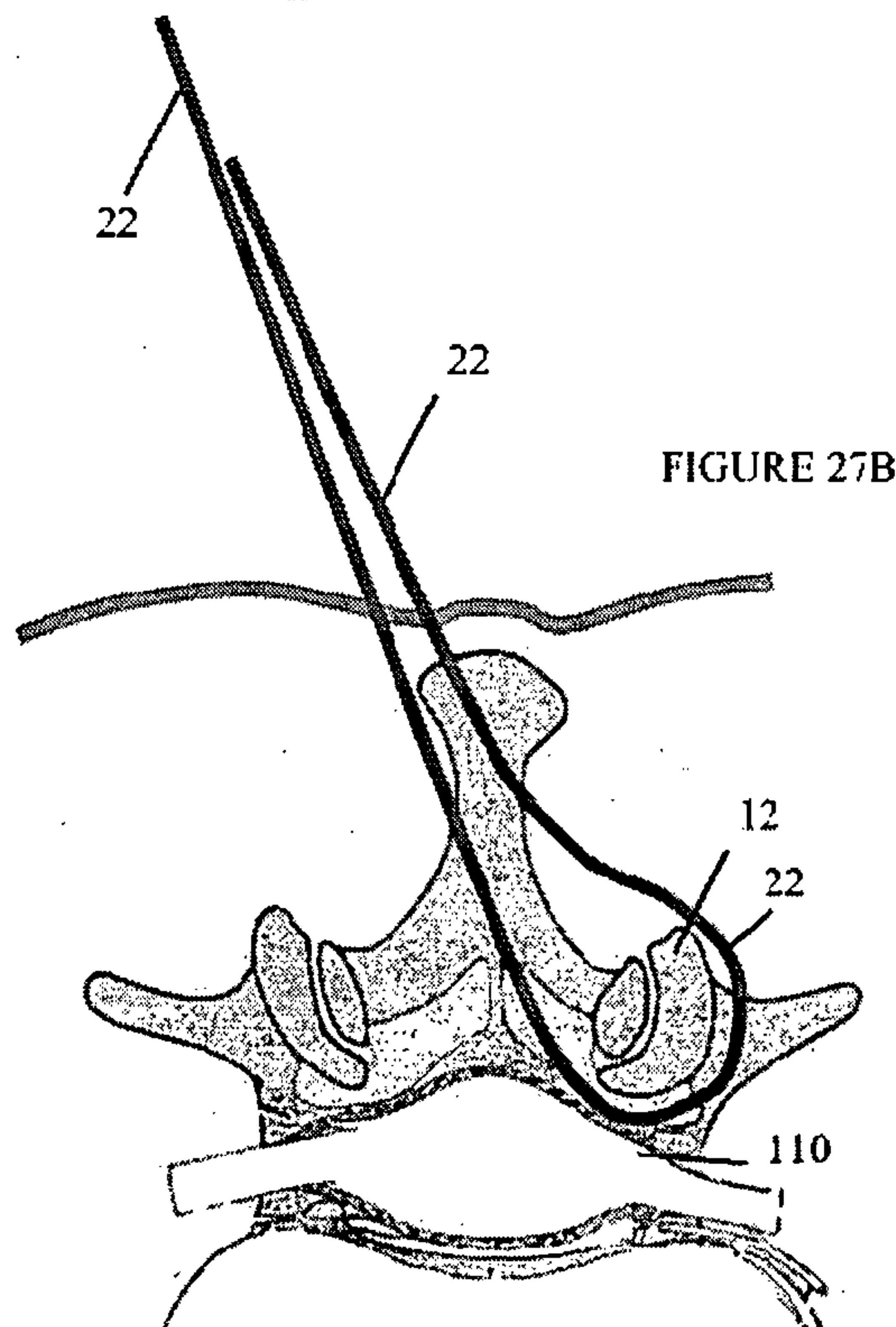
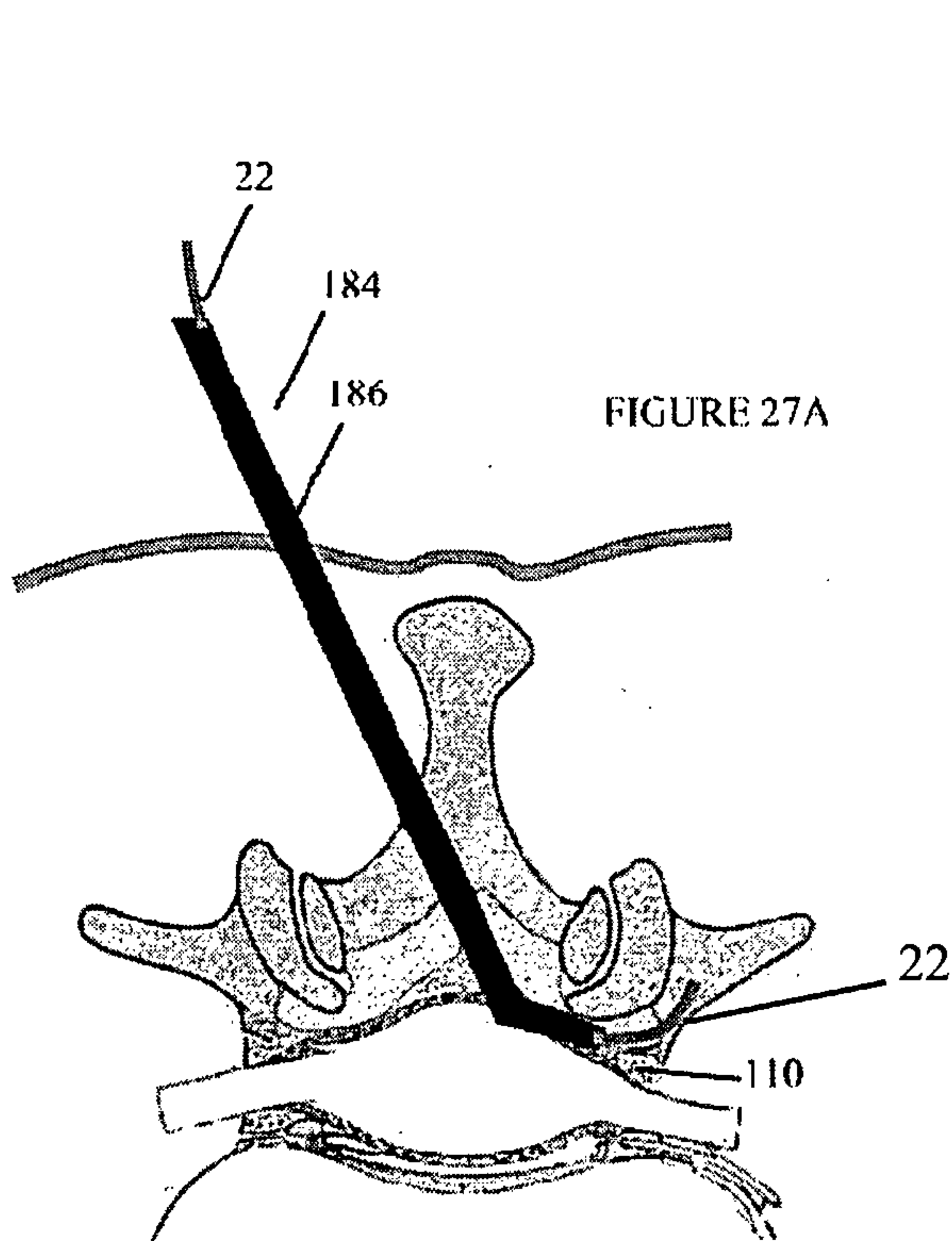
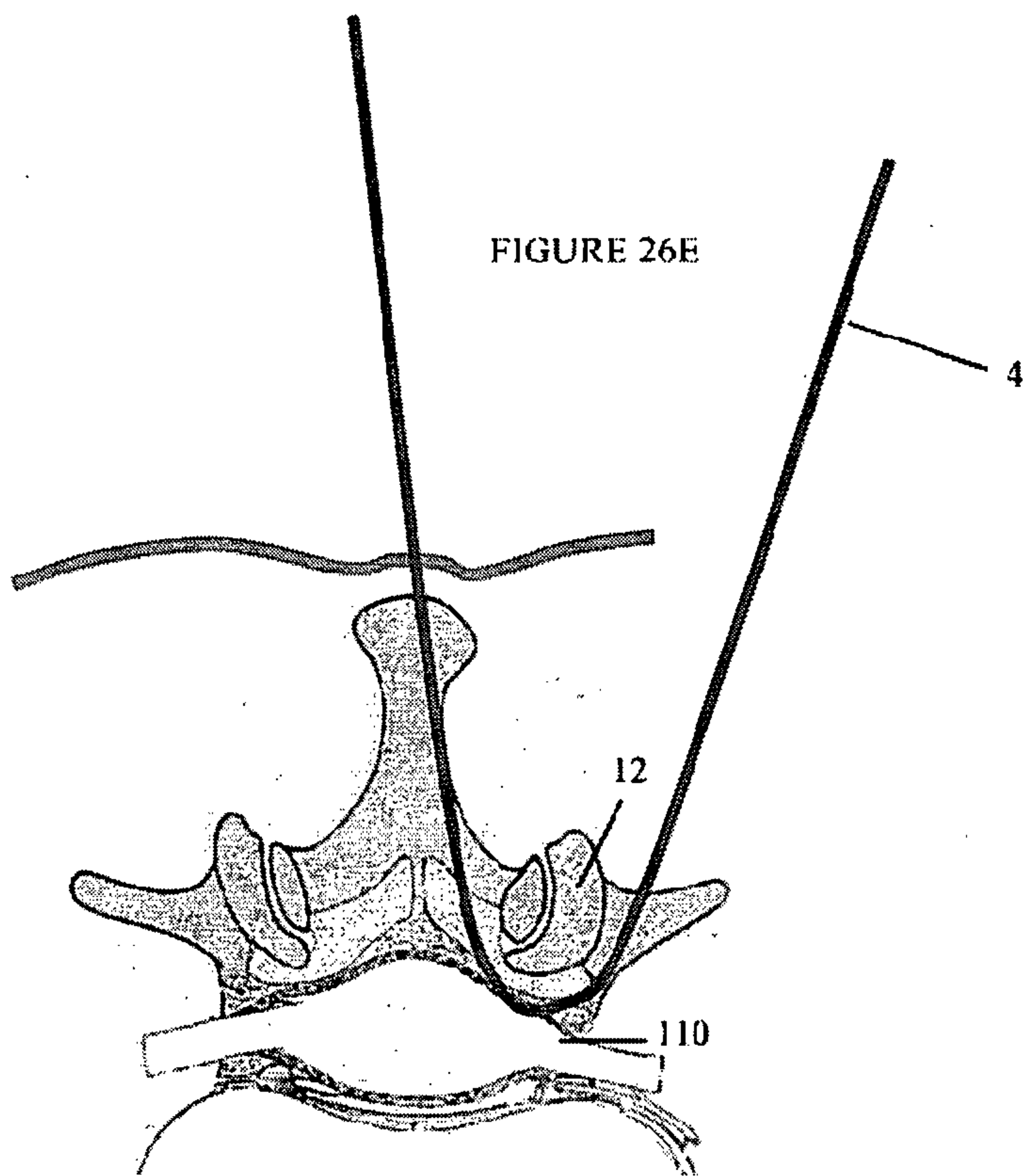

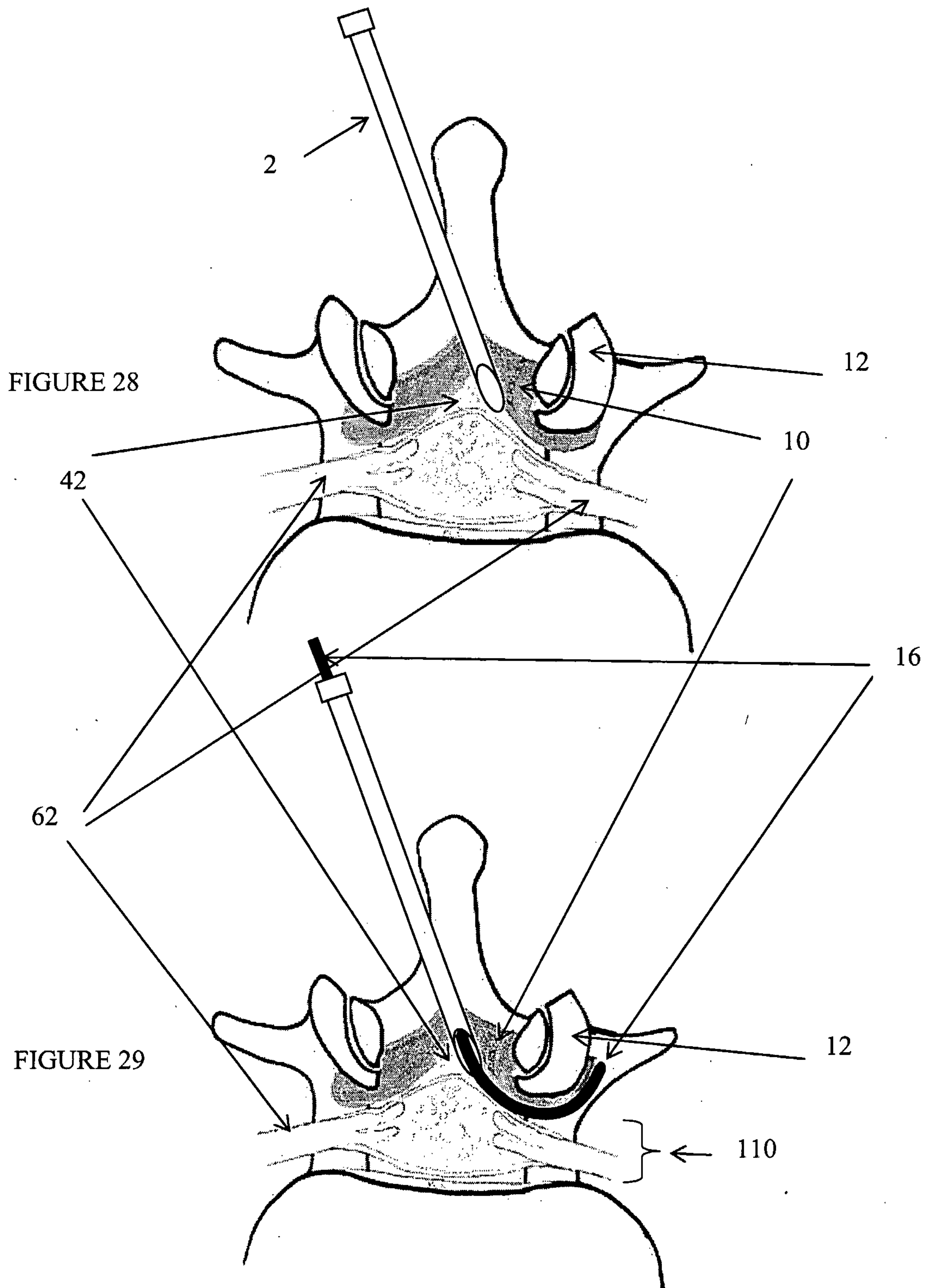

FIGURE 30

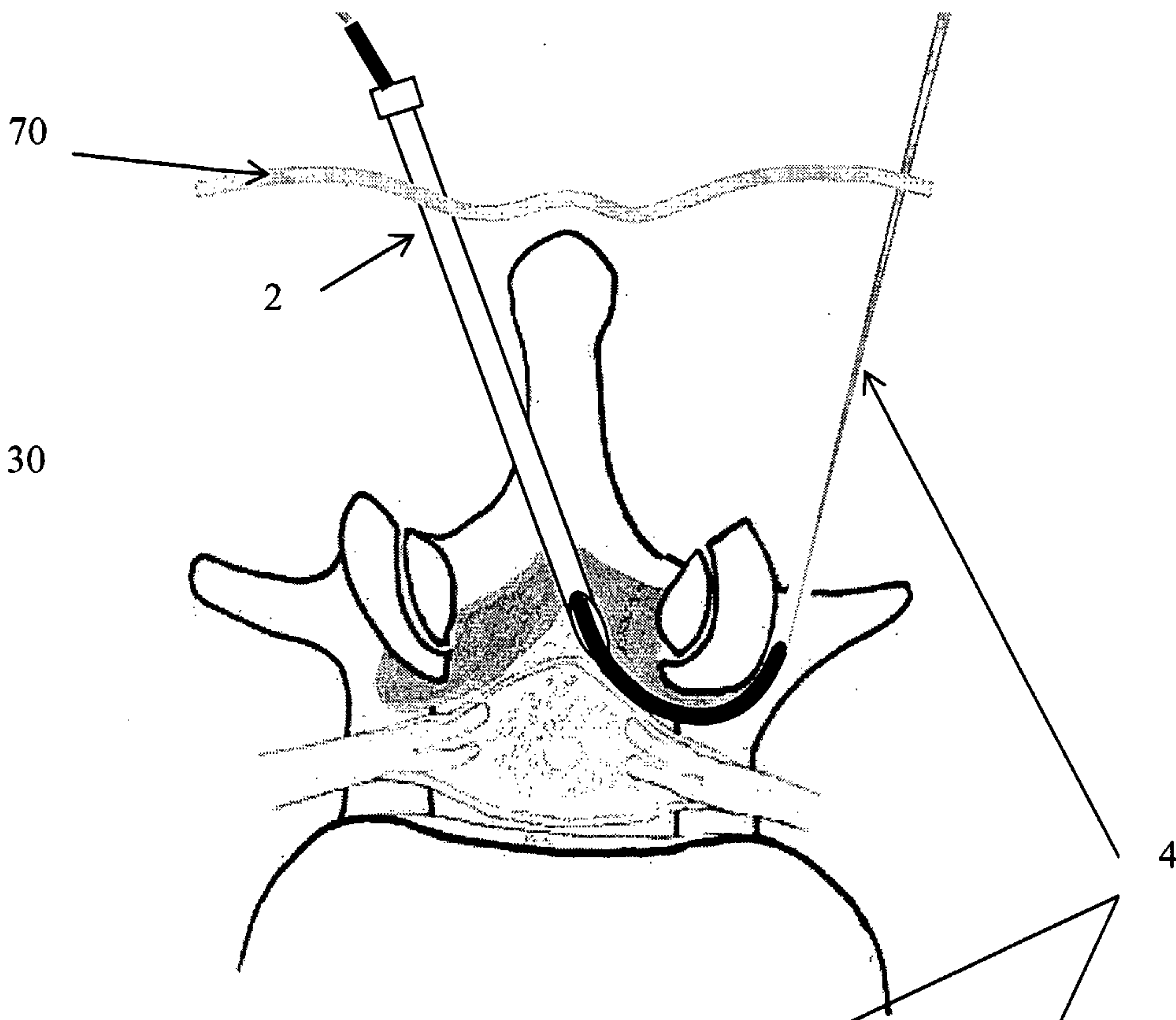

FIGURE 31

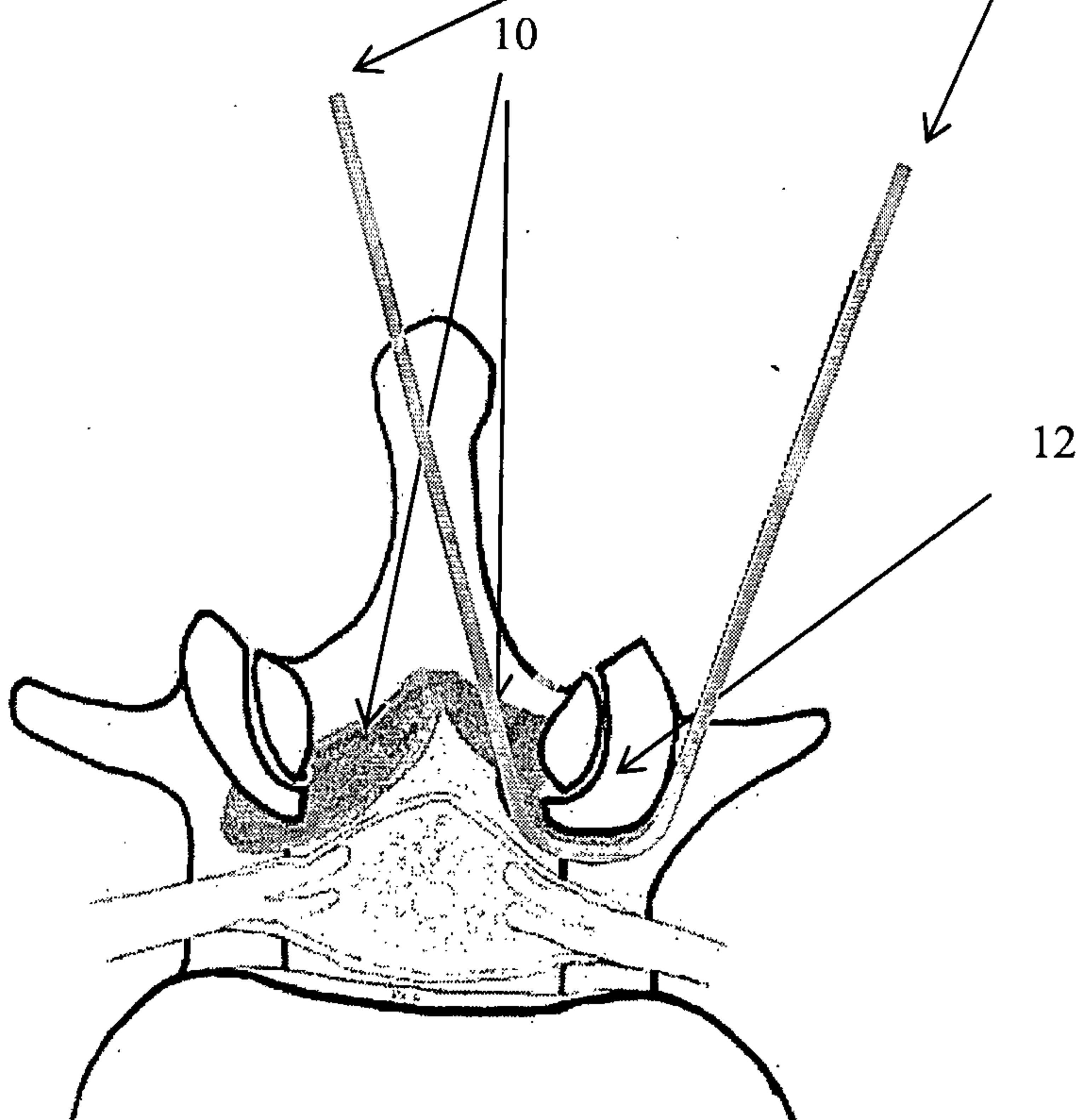



FIGURE 32

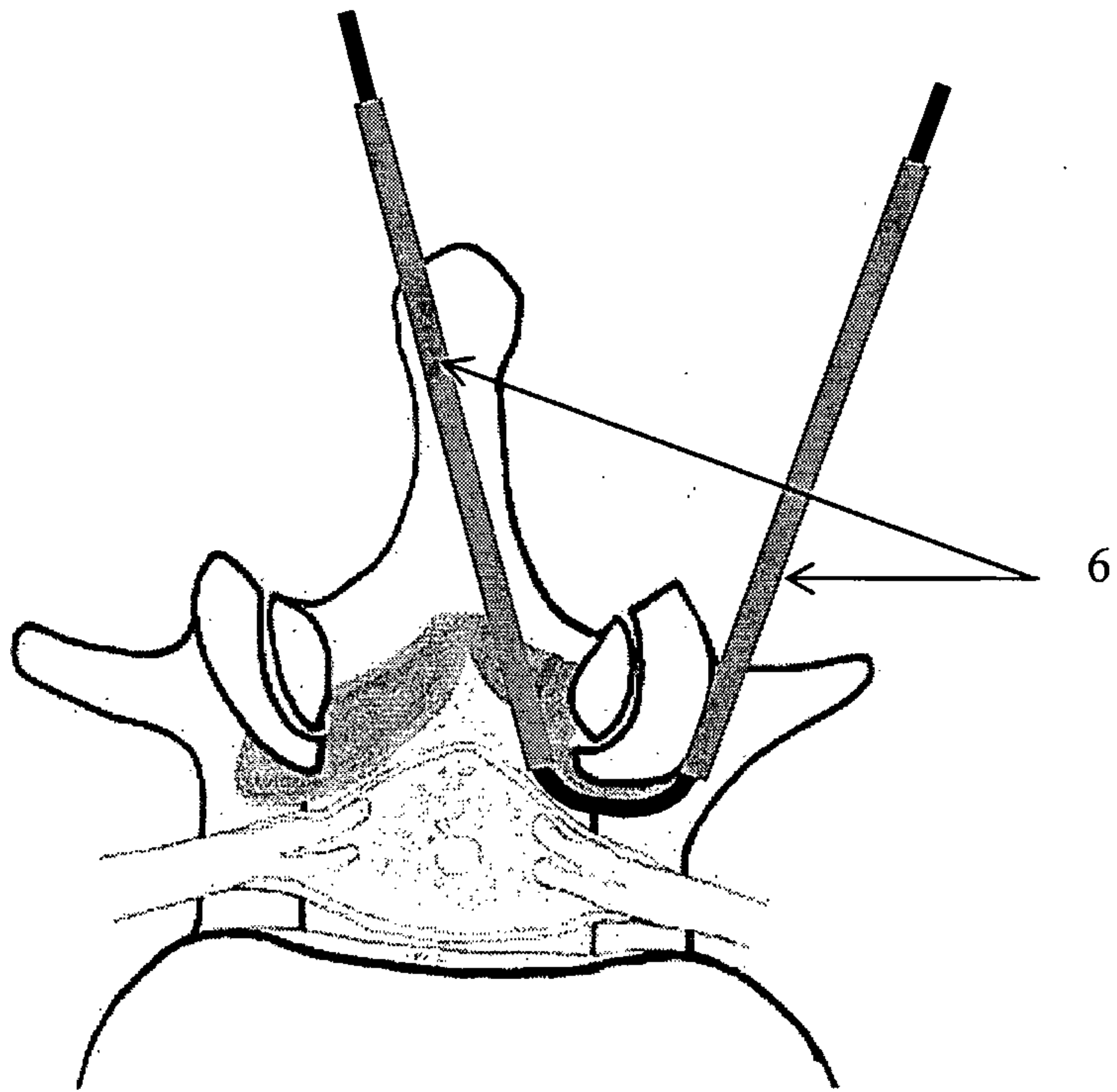
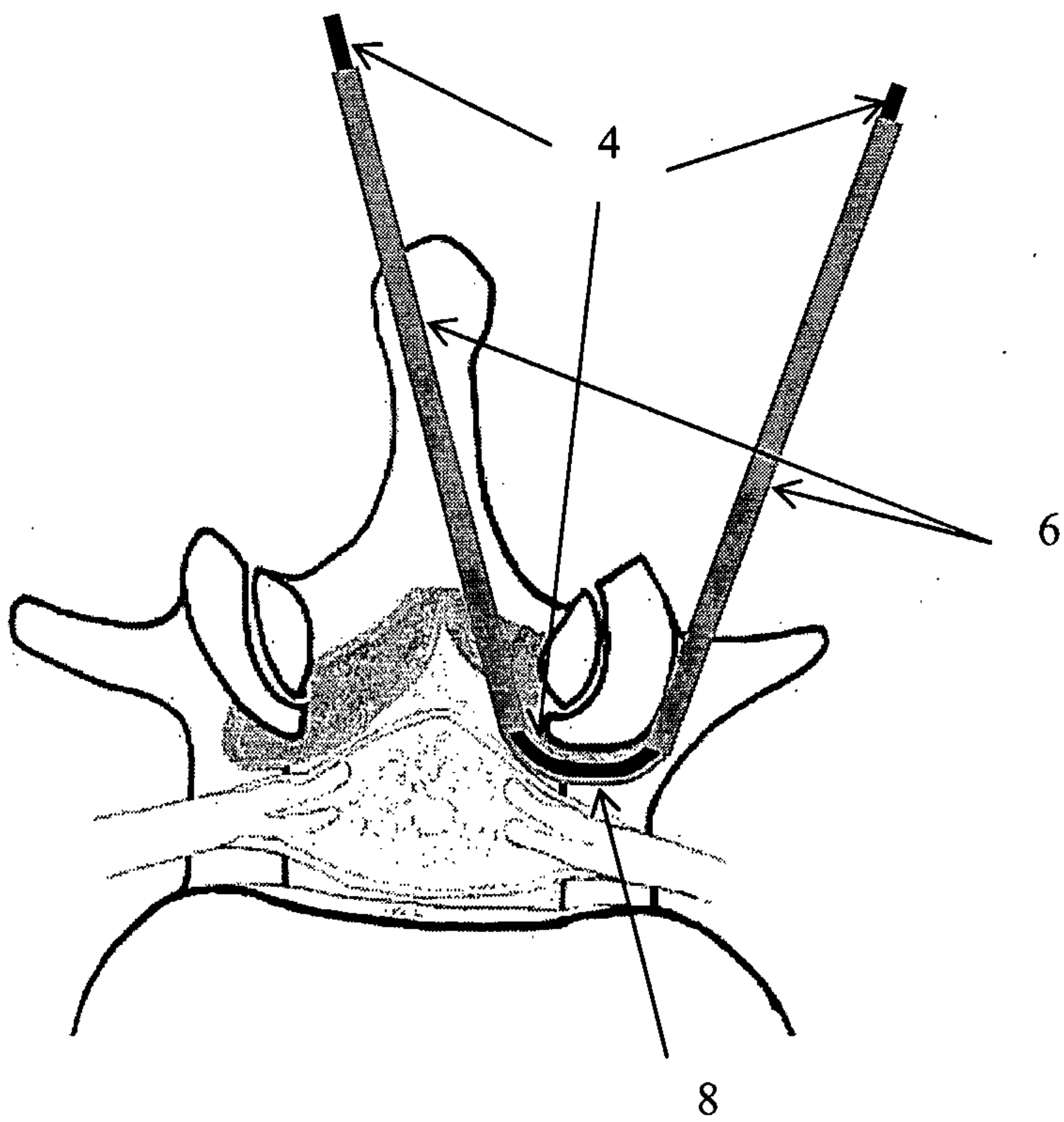

FIGURE 33



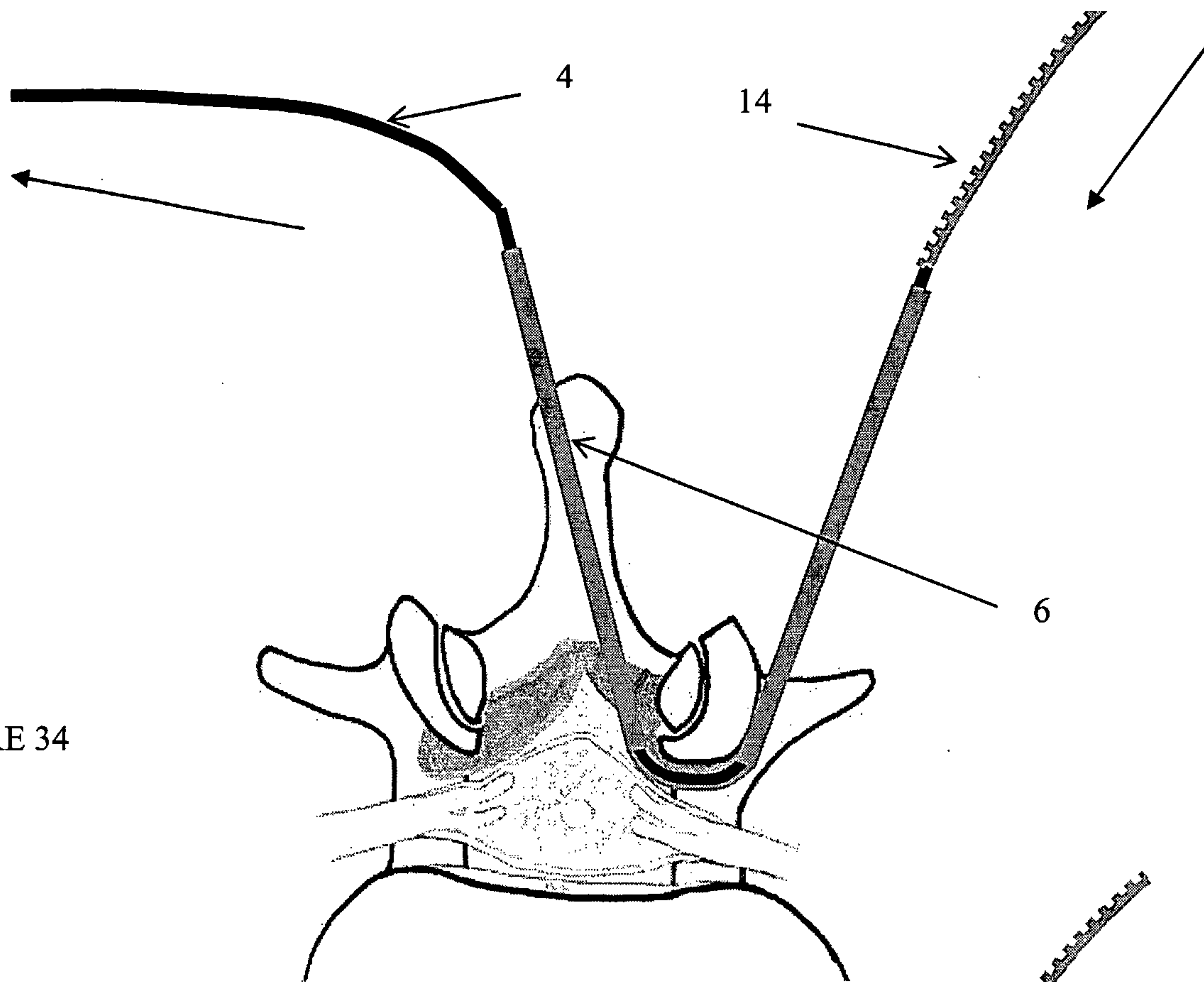

FIGURE 34

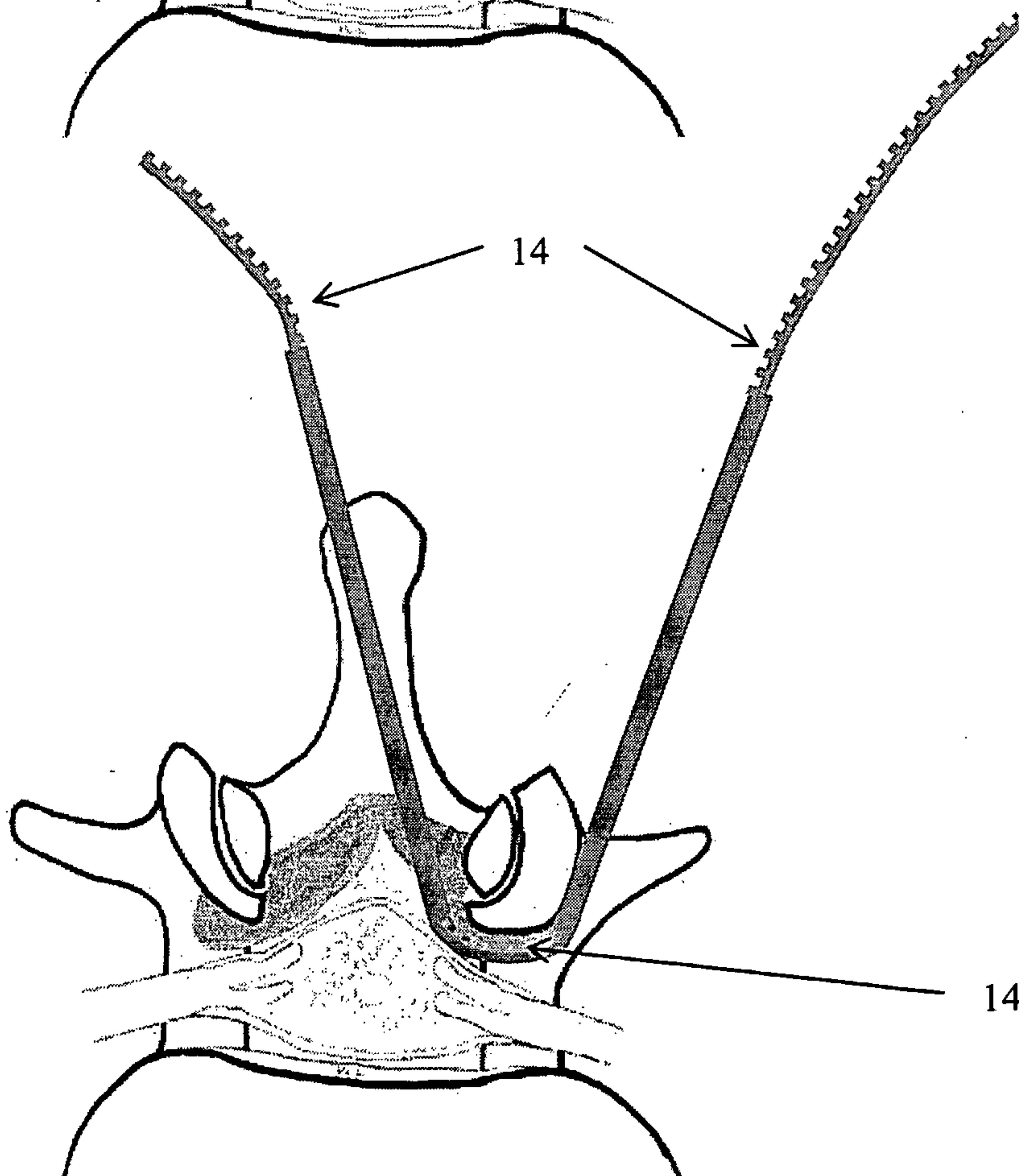

FIGURE 35

FIGURE 36

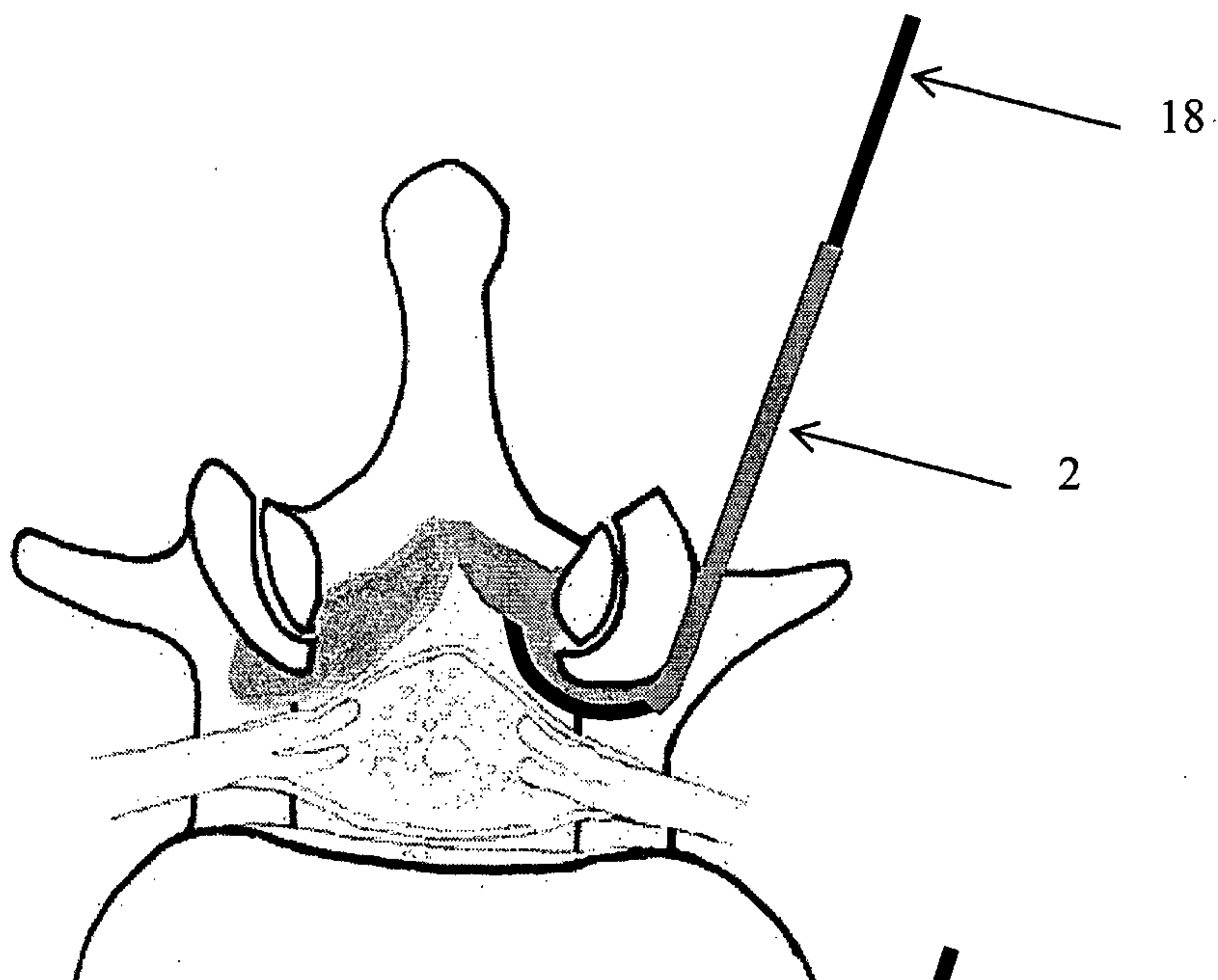

FIGURE 37

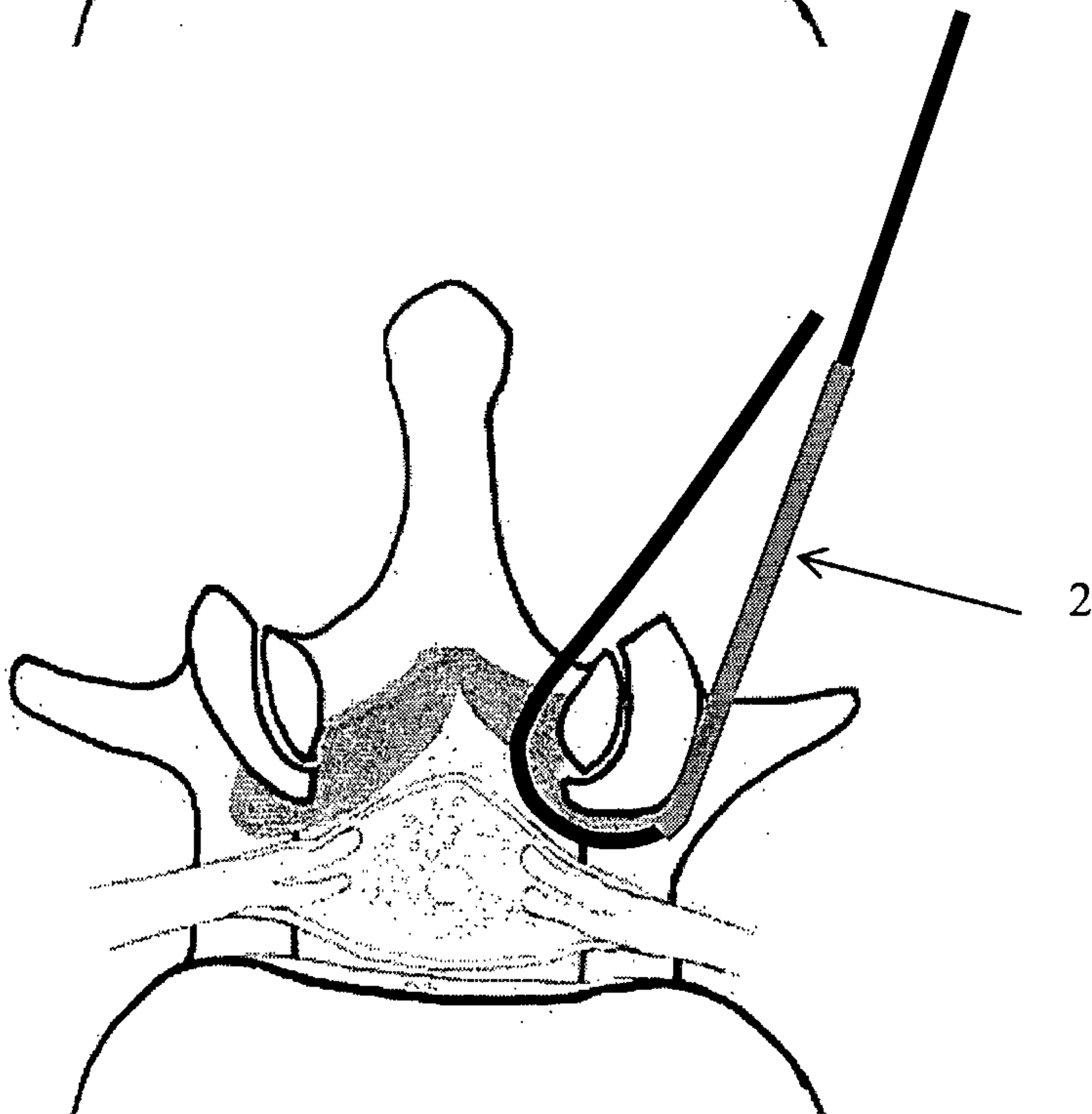



FIGURE 38

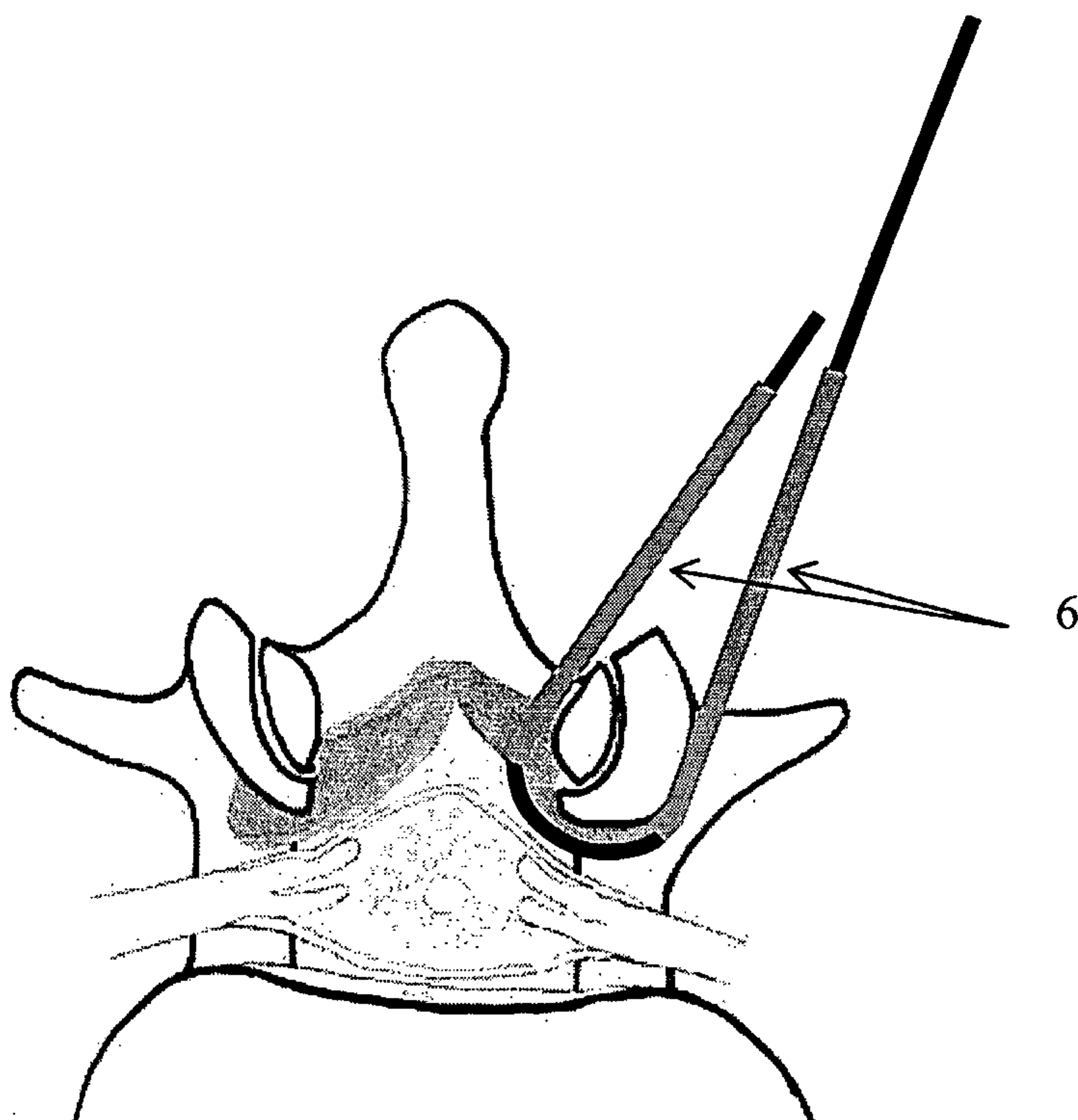

FIGURE 39

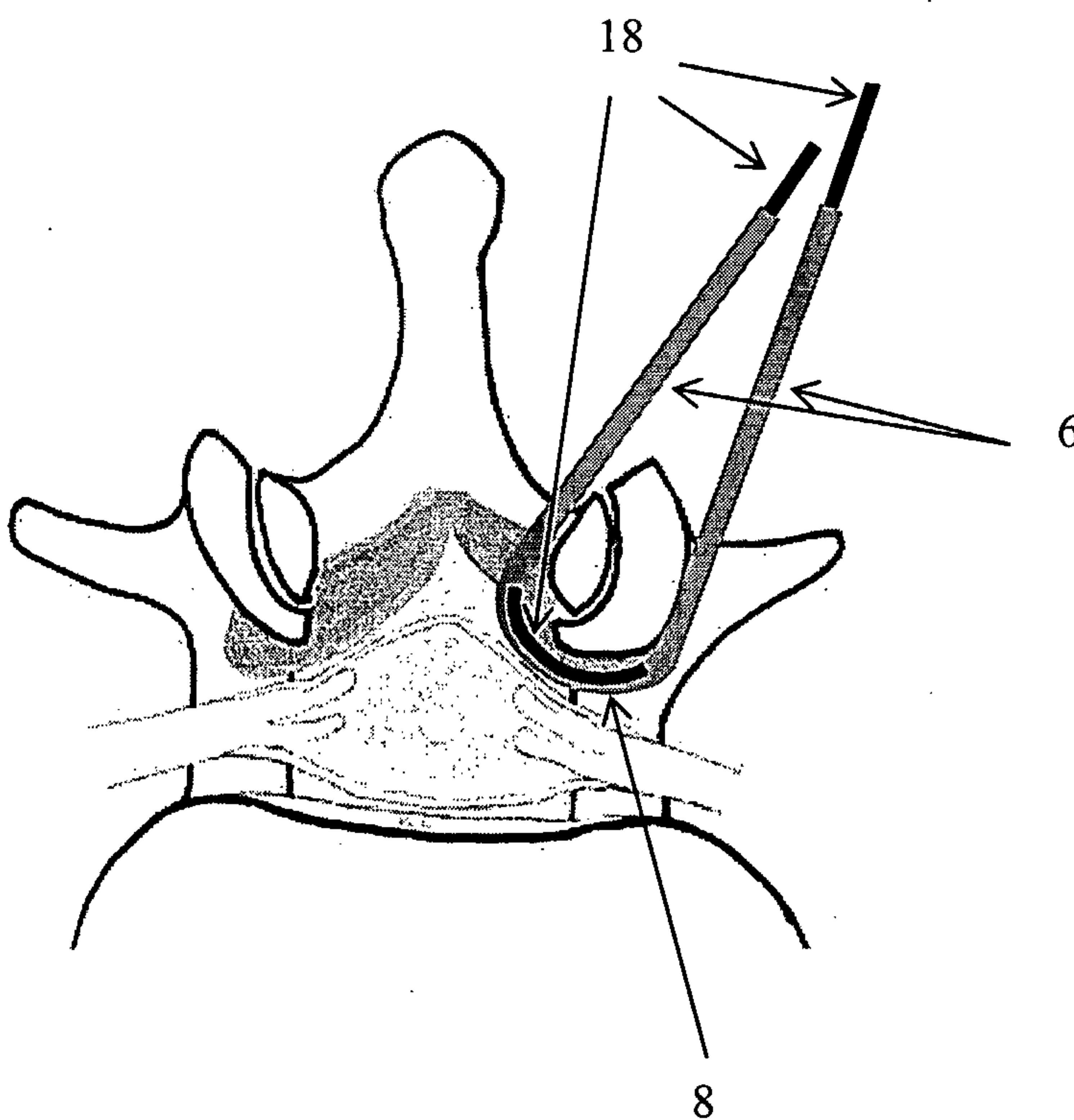
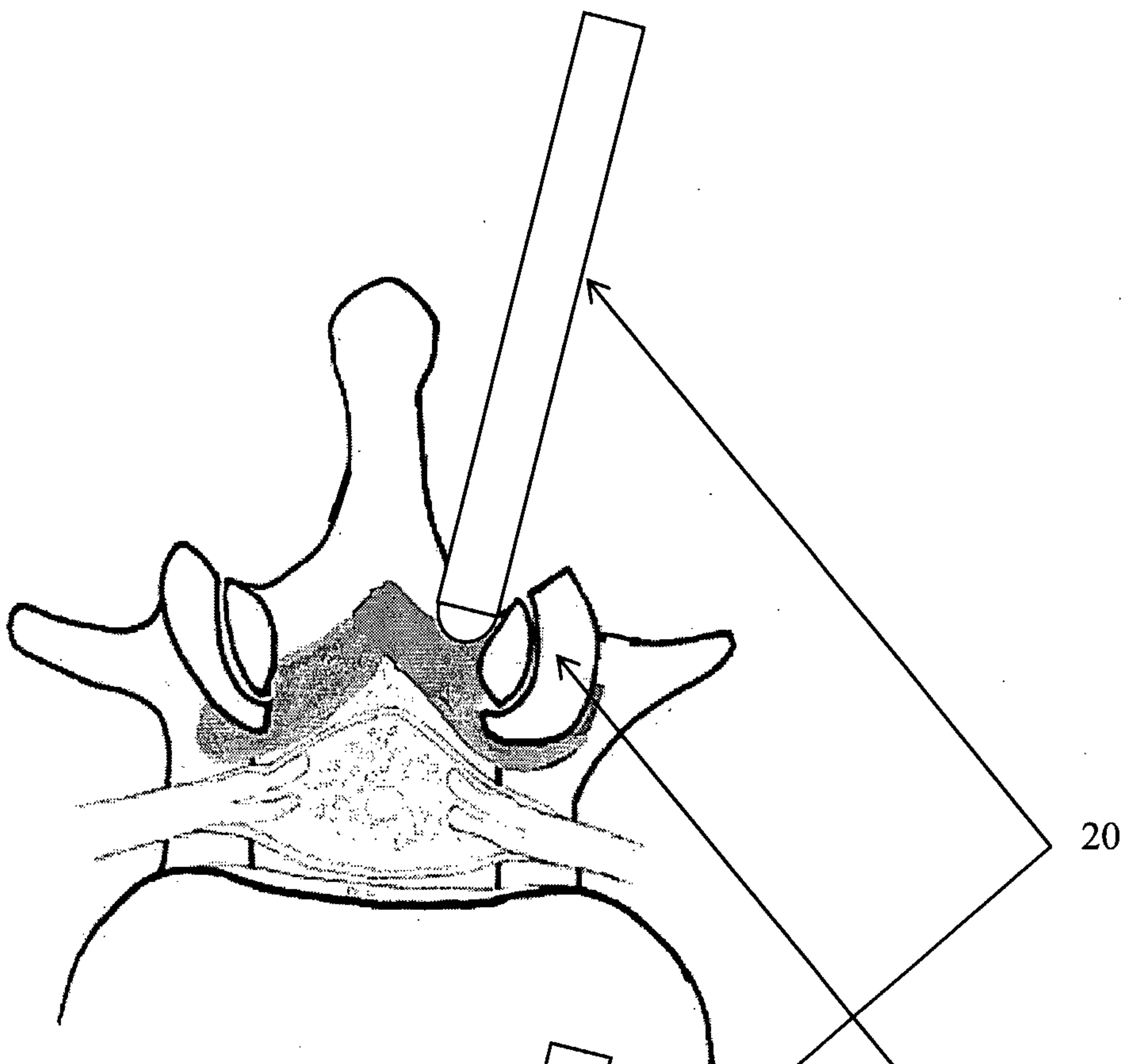

FIGURE 40a



FIGURES 40b

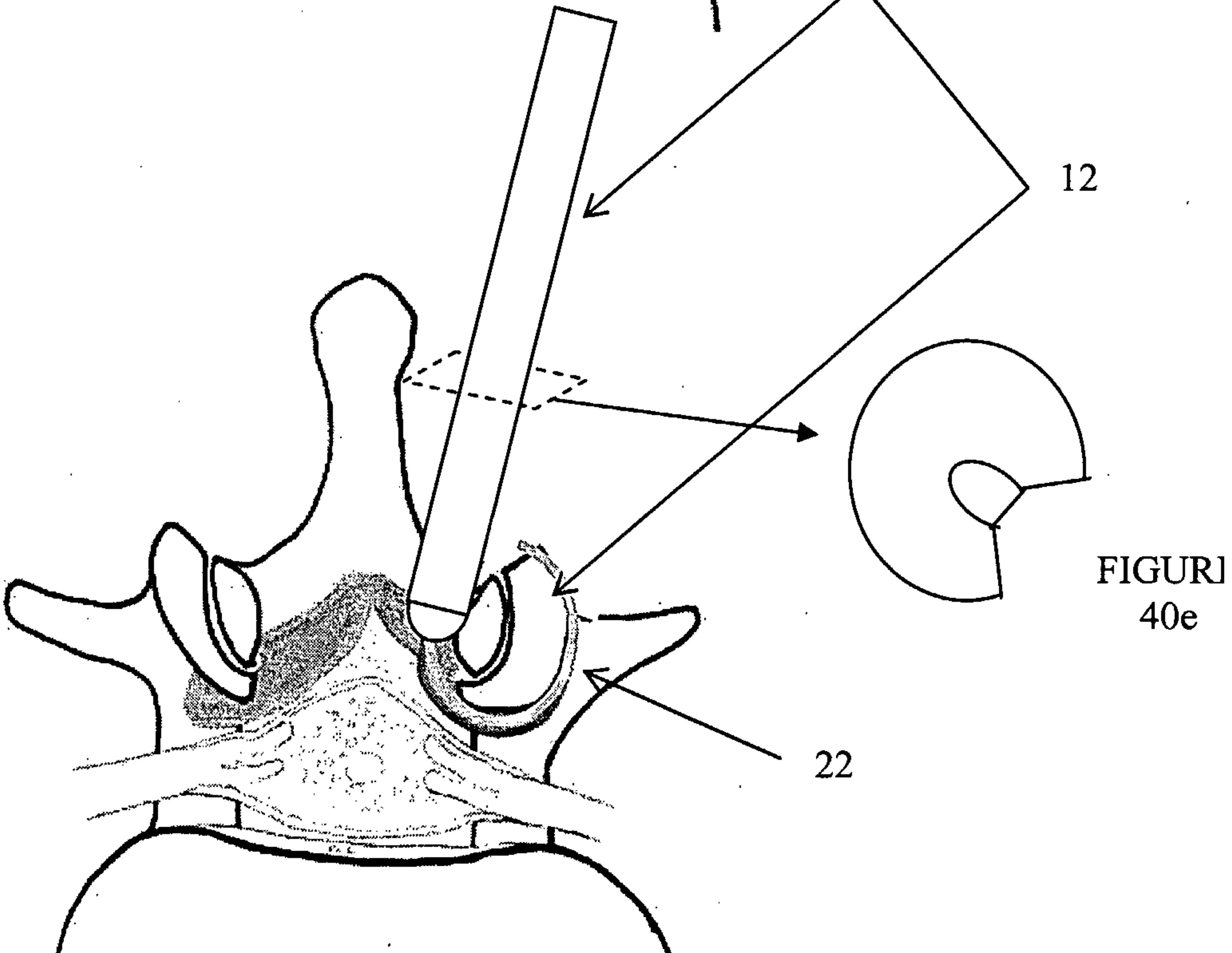



FIGURE 40c

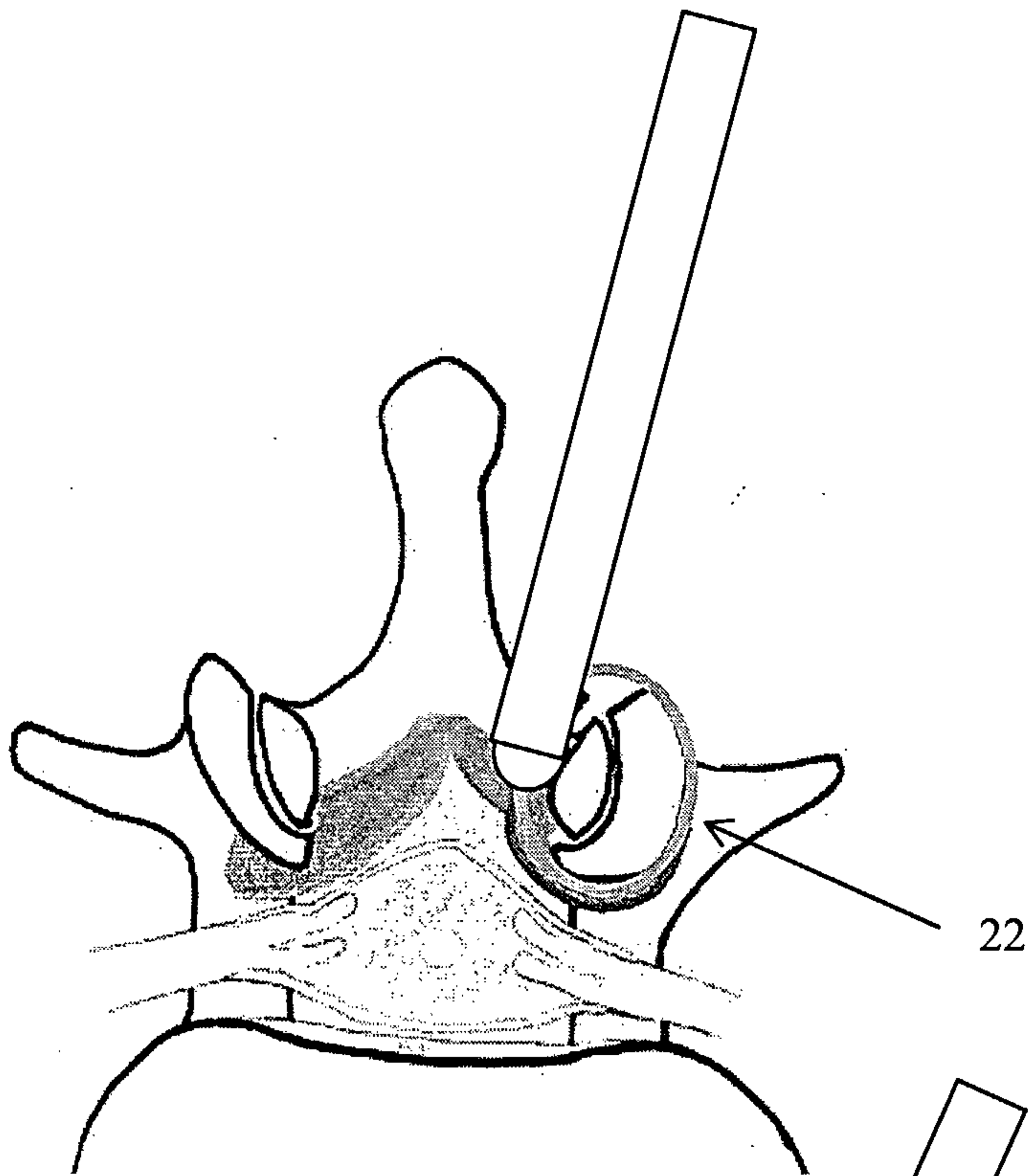
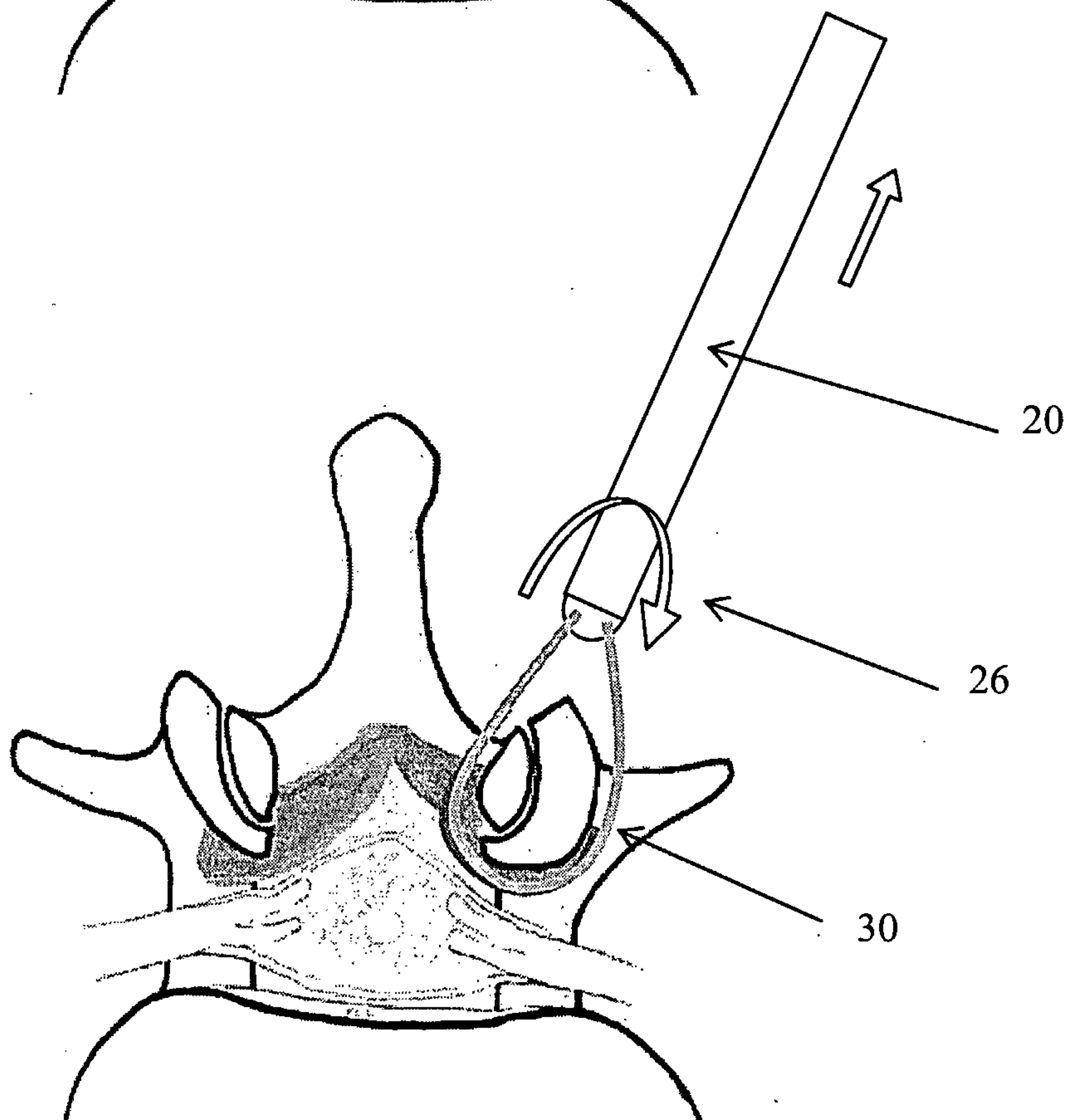

FIGURE 40d



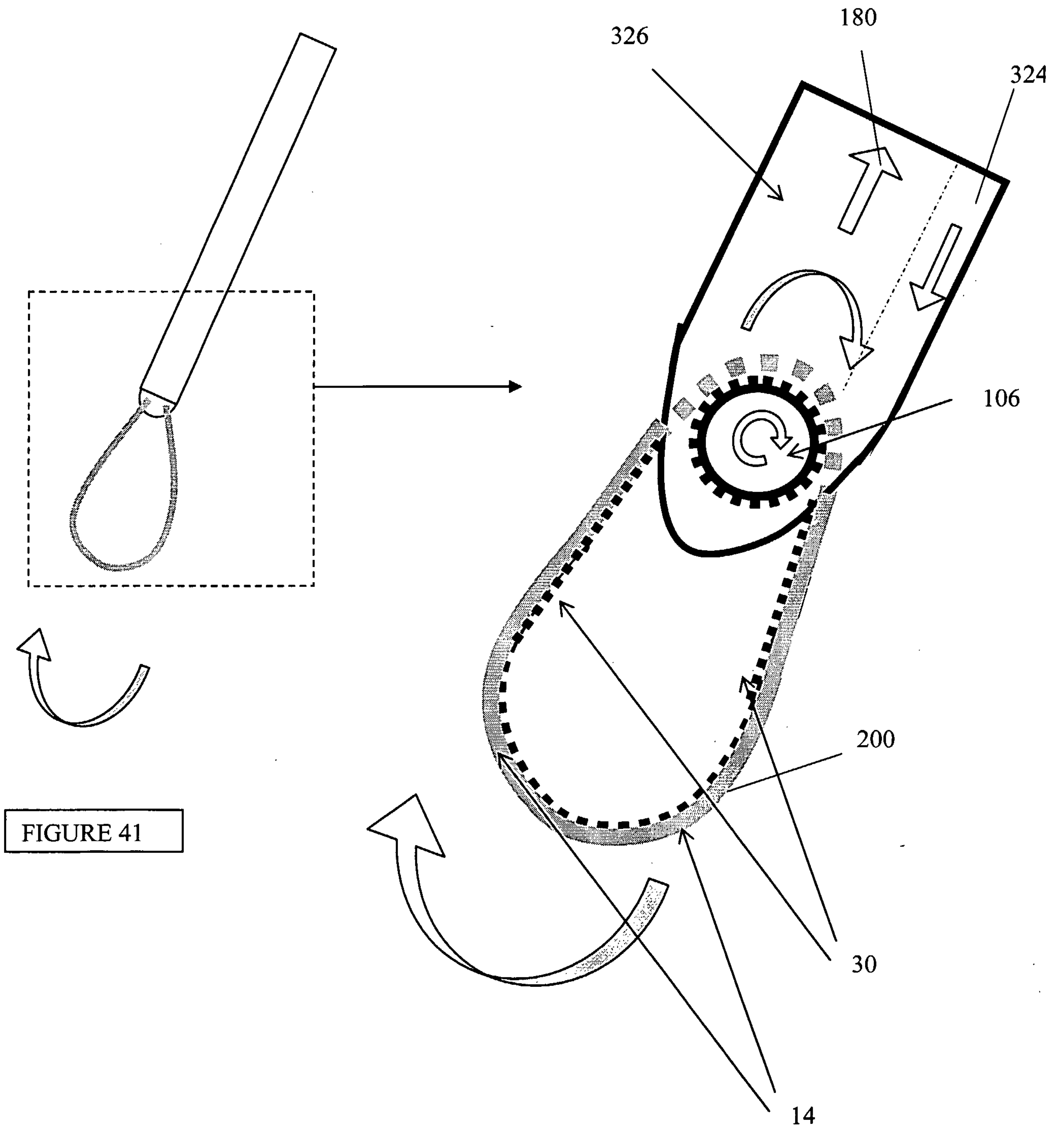

FIGURE 41



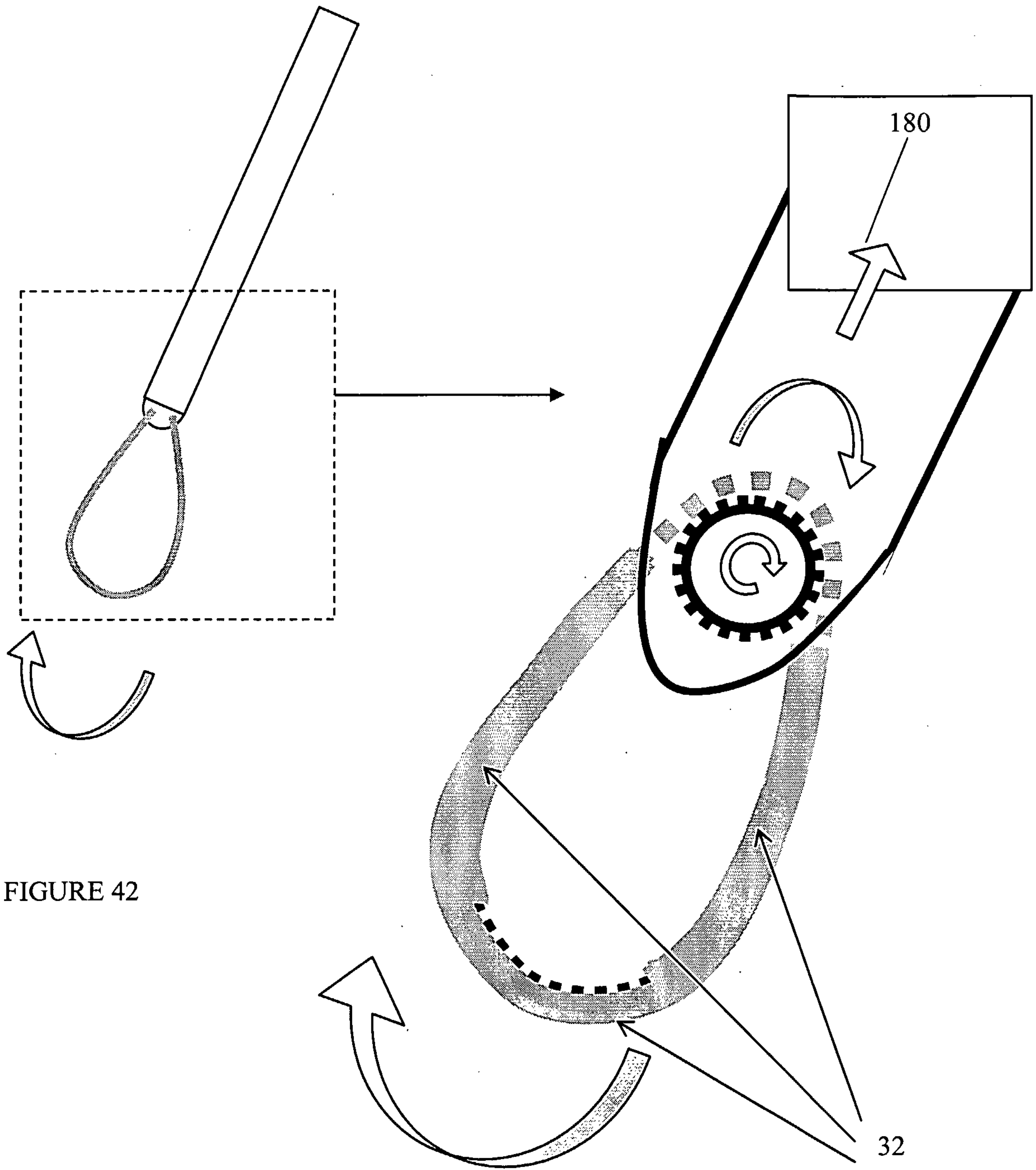

FIGURE 42

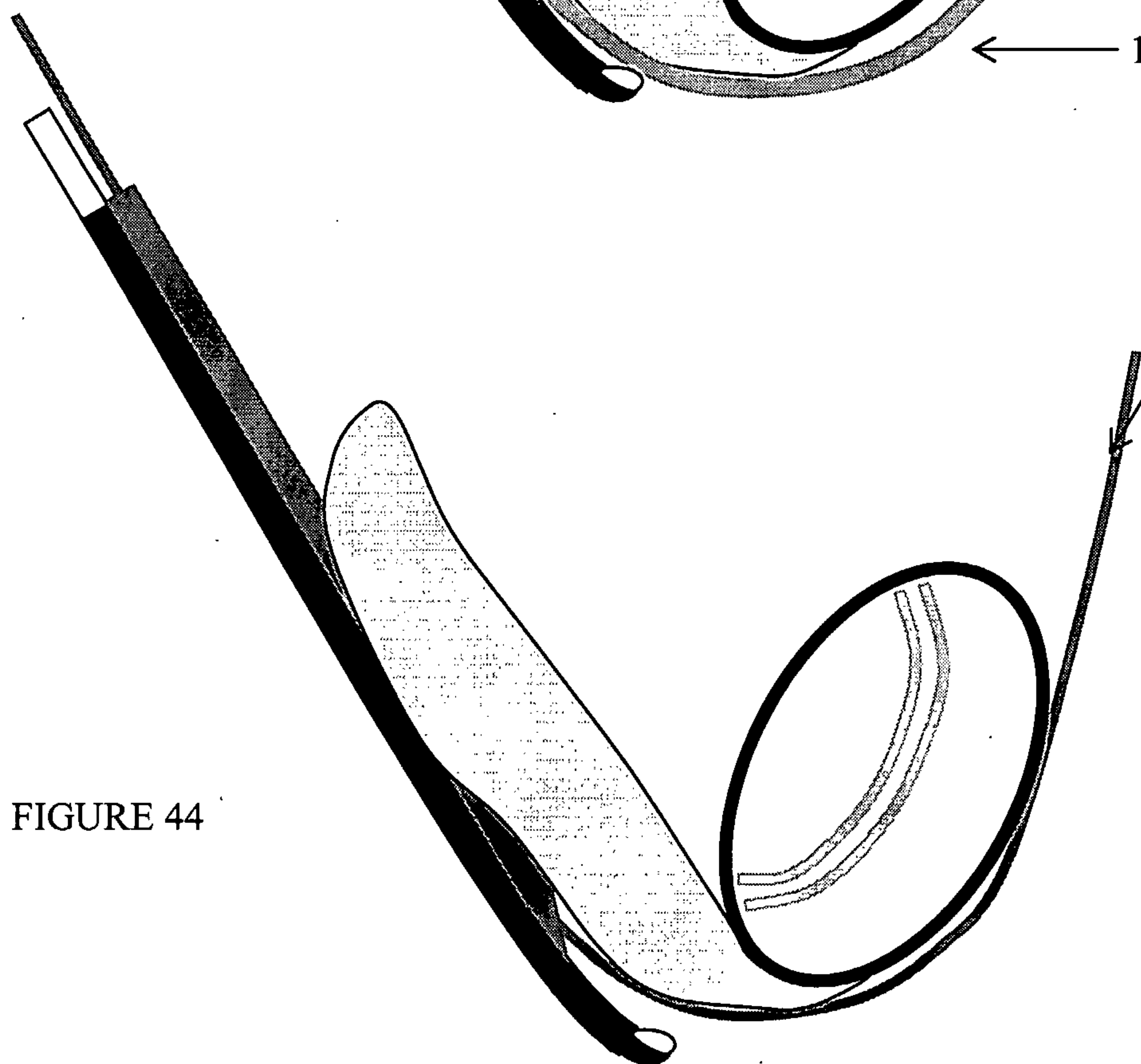
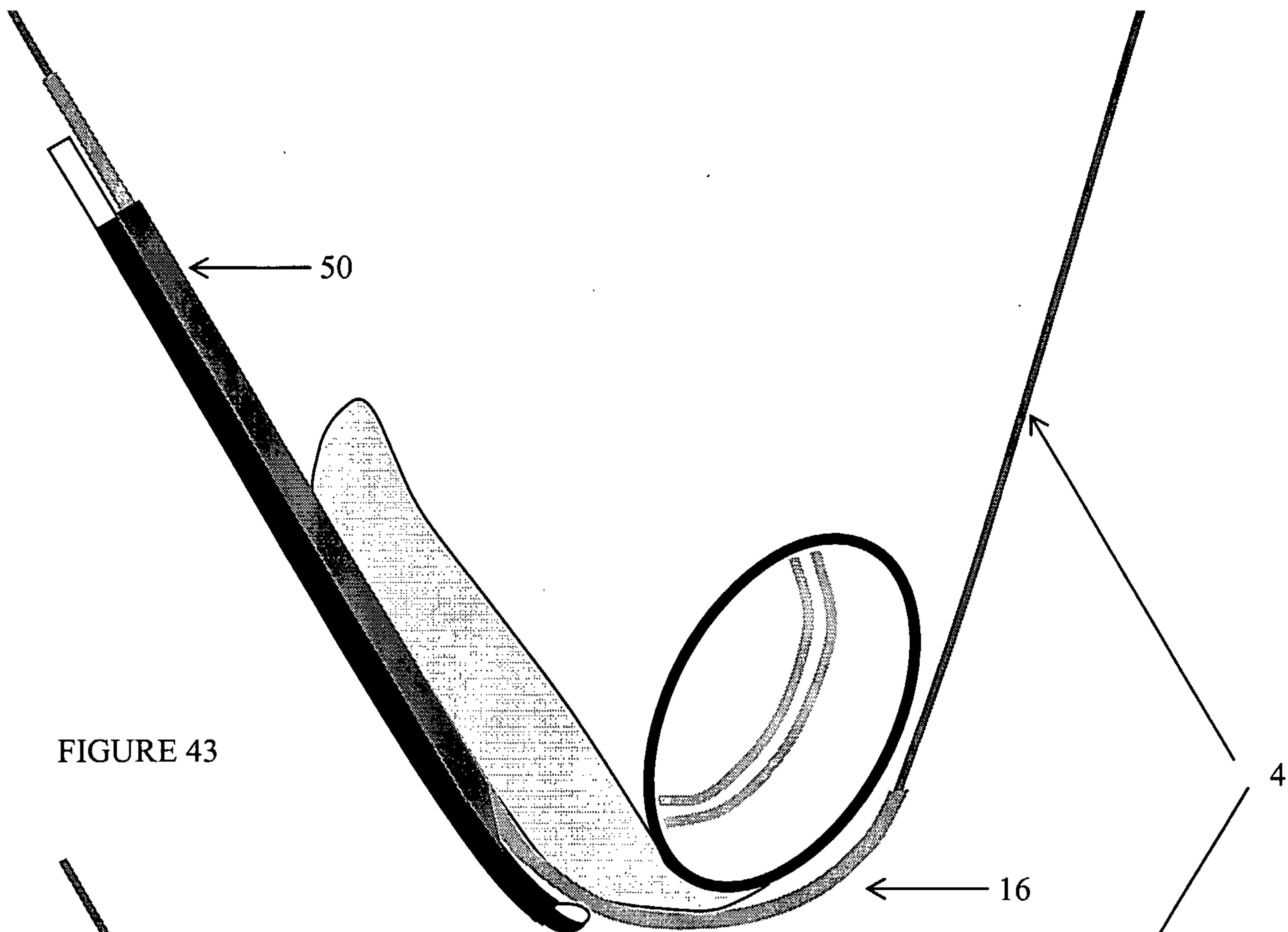



FIGURE 45

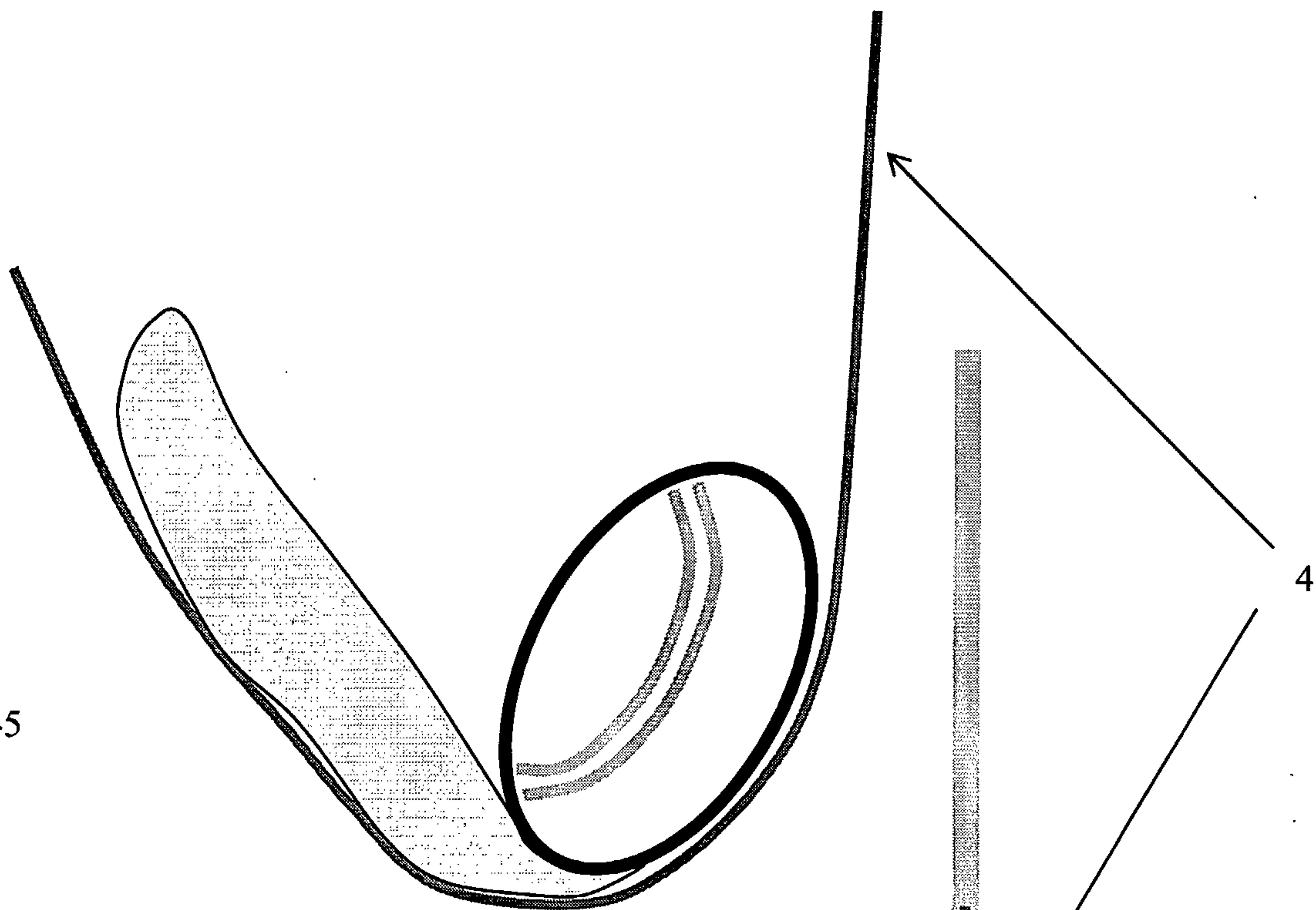
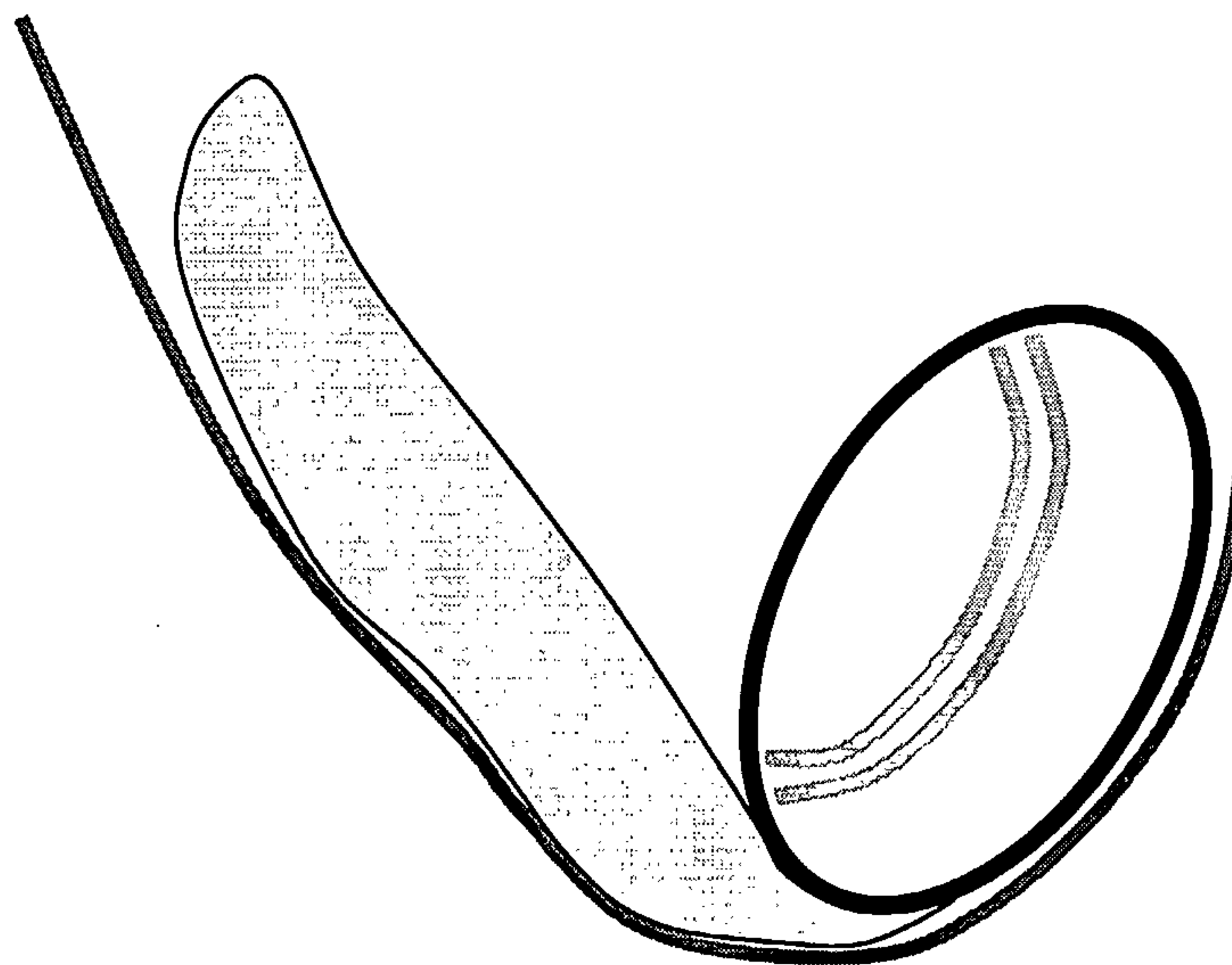
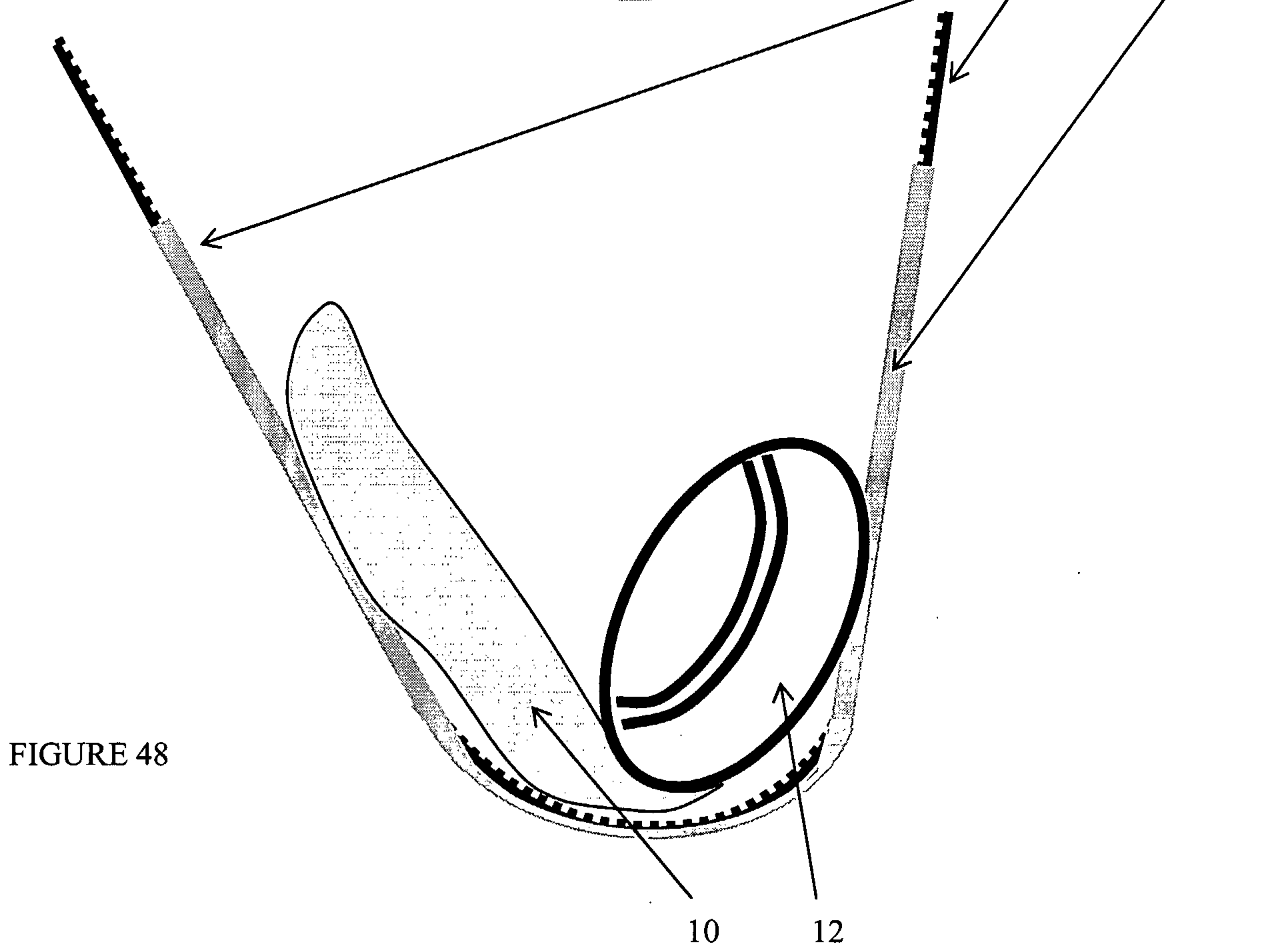
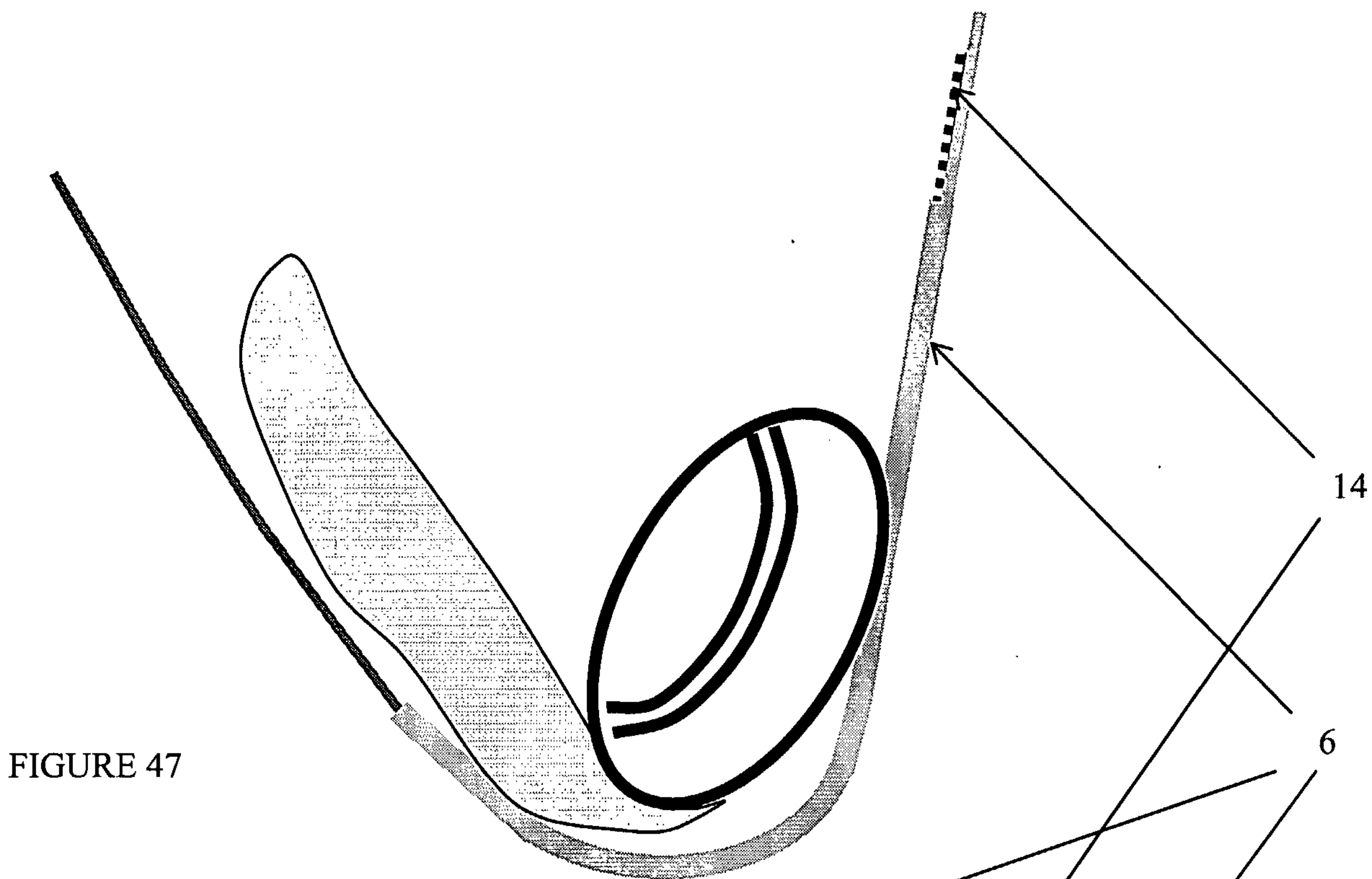

FIGURE 46







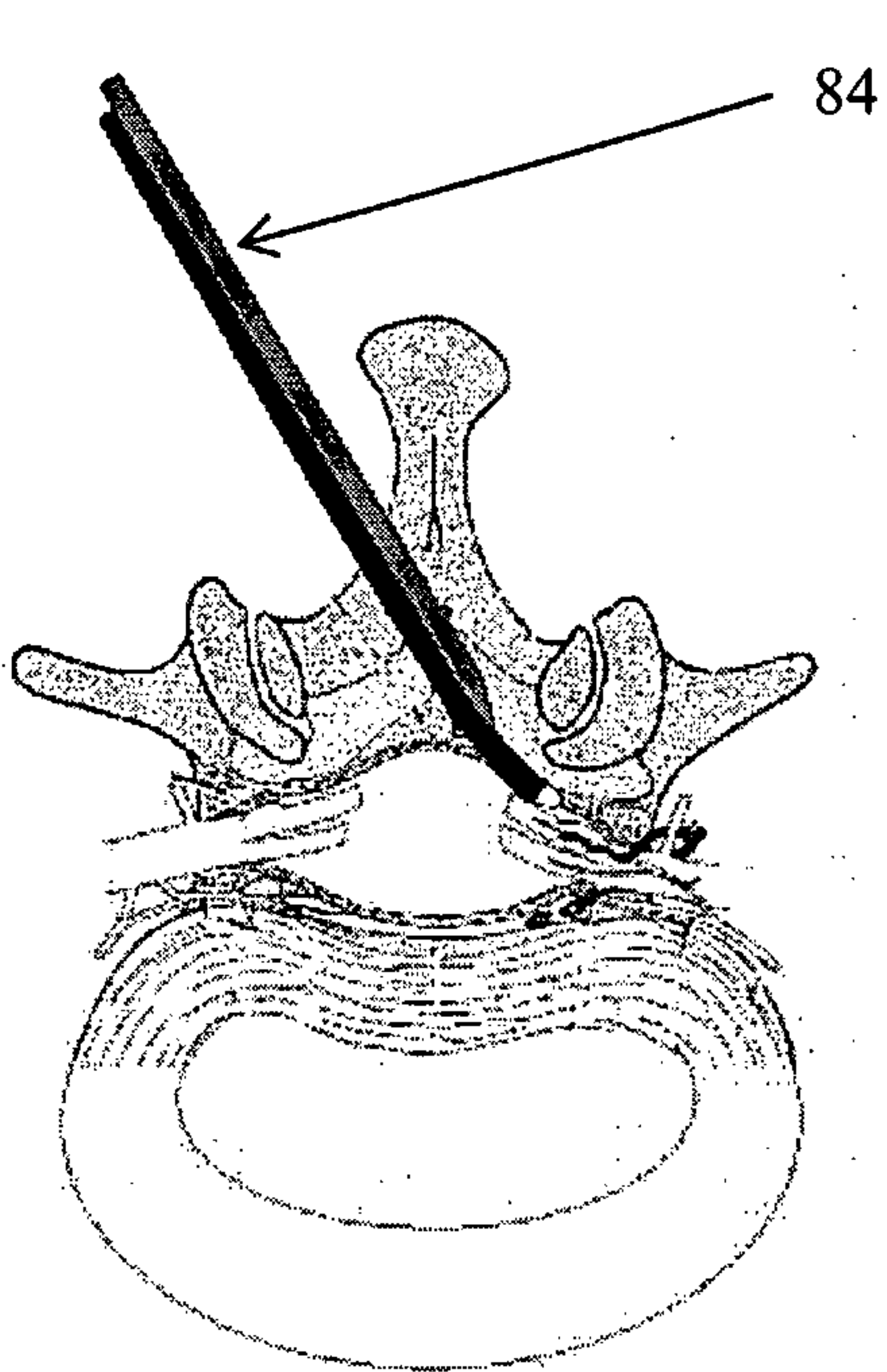

FIGURE 49

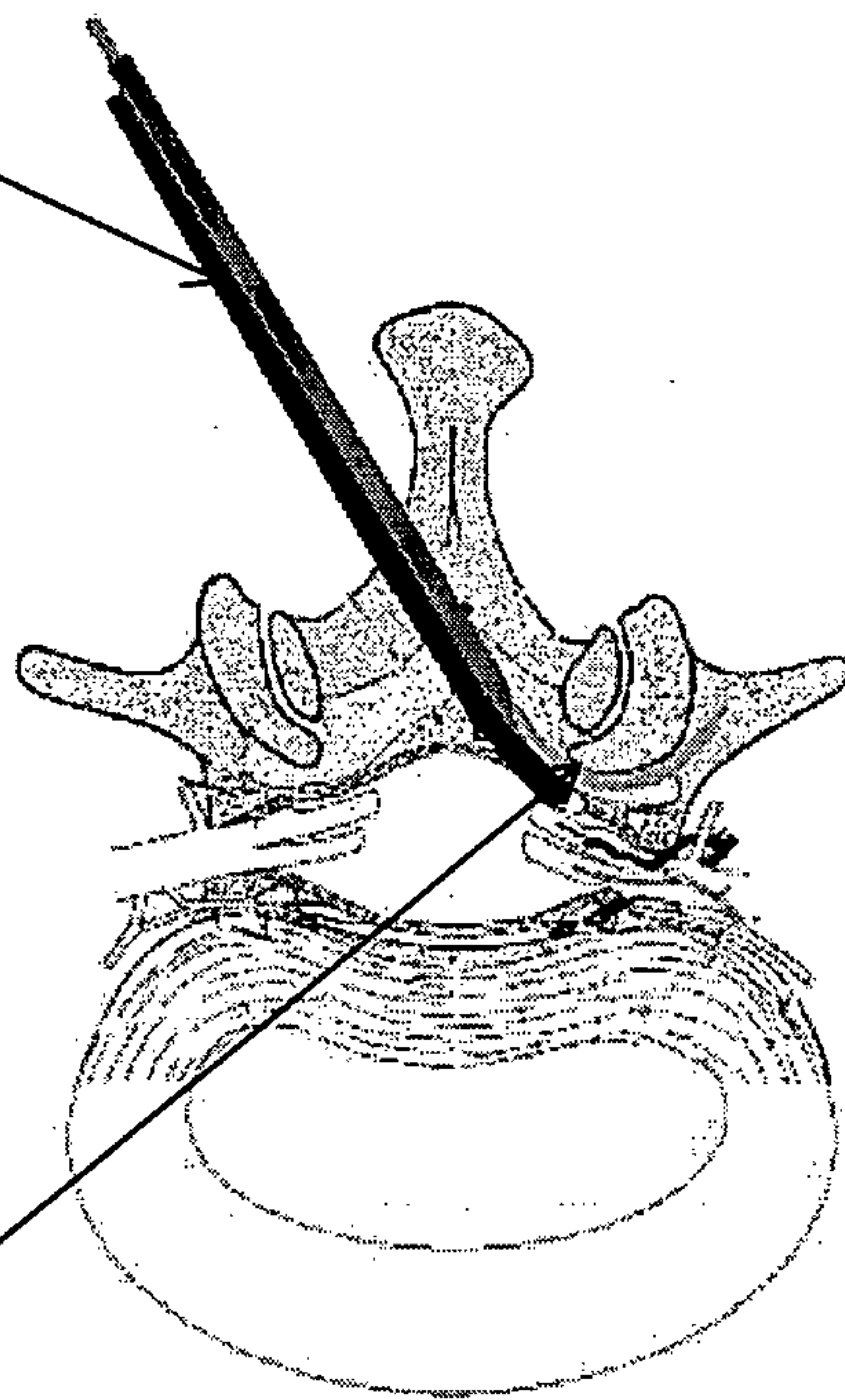

FIGURE 50

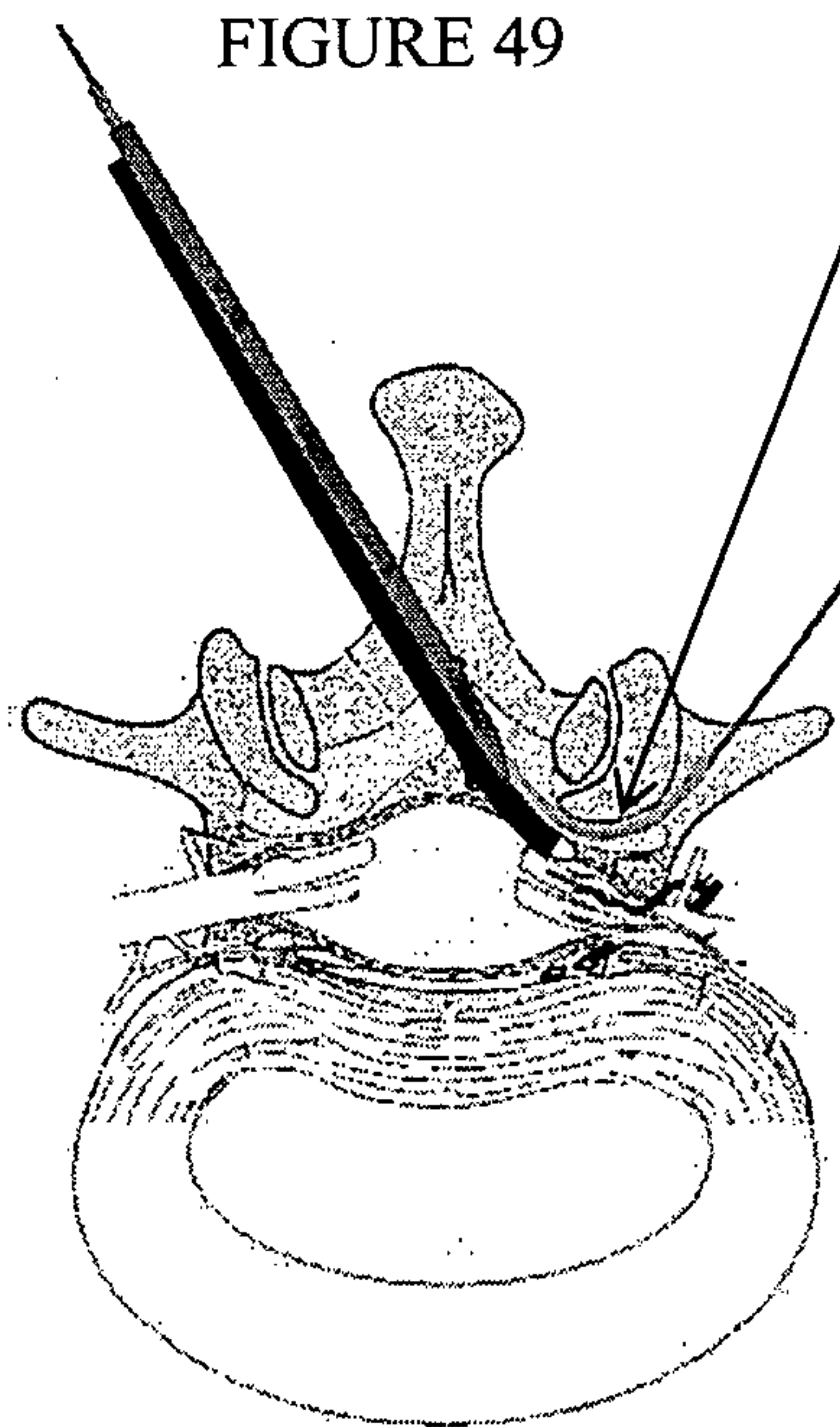

FIGURE 51

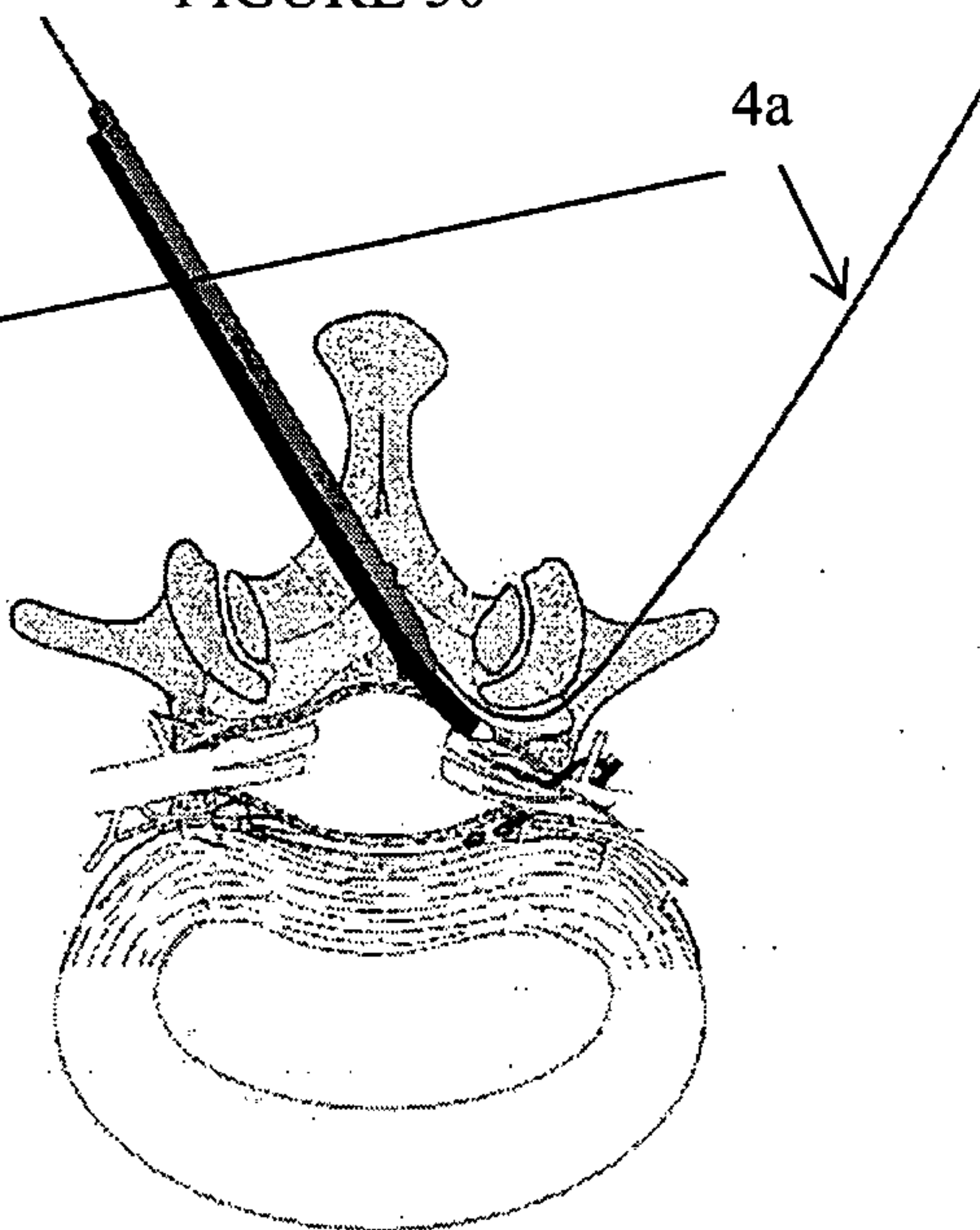

FIGURE 52

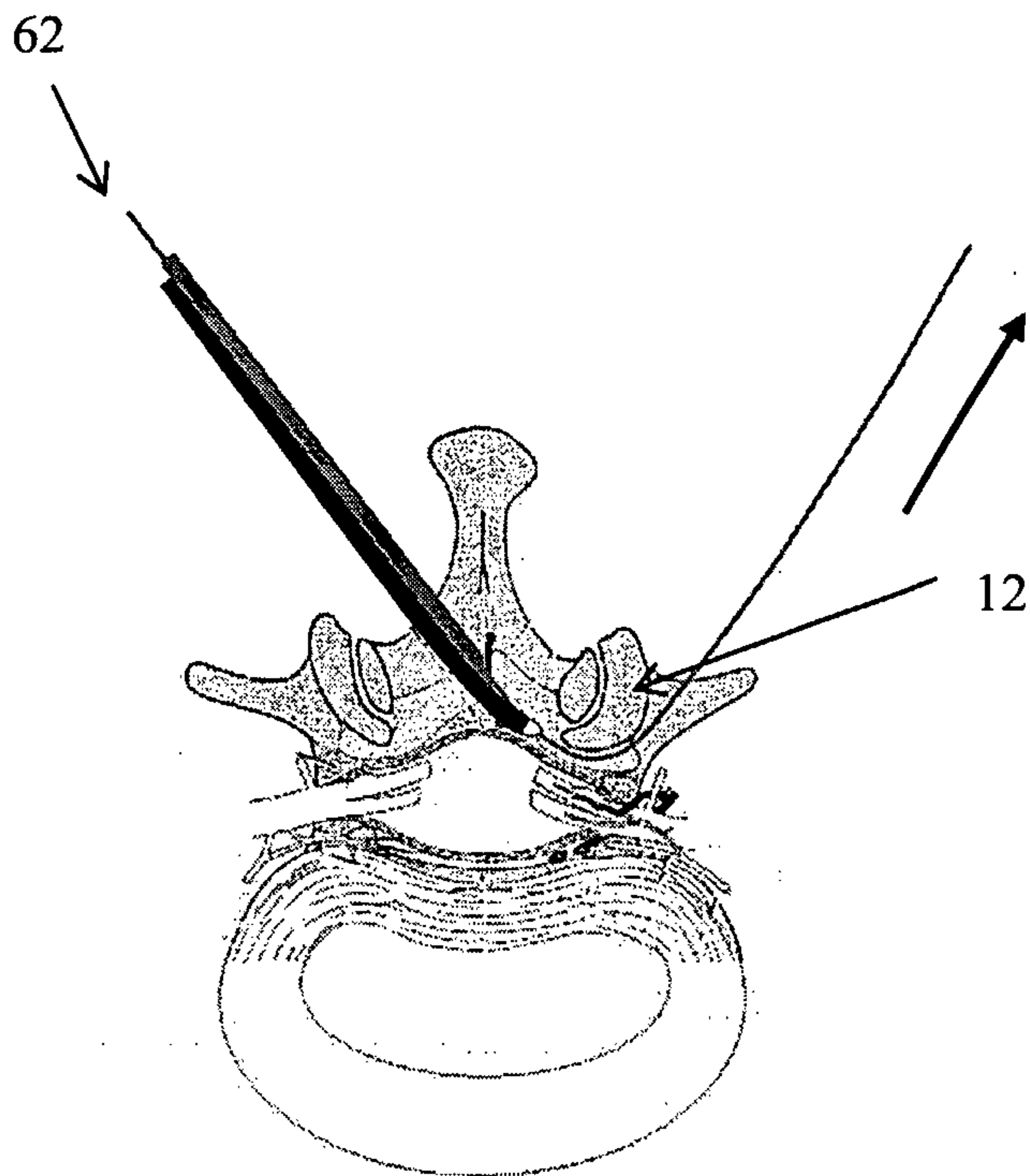

FIGURE 53

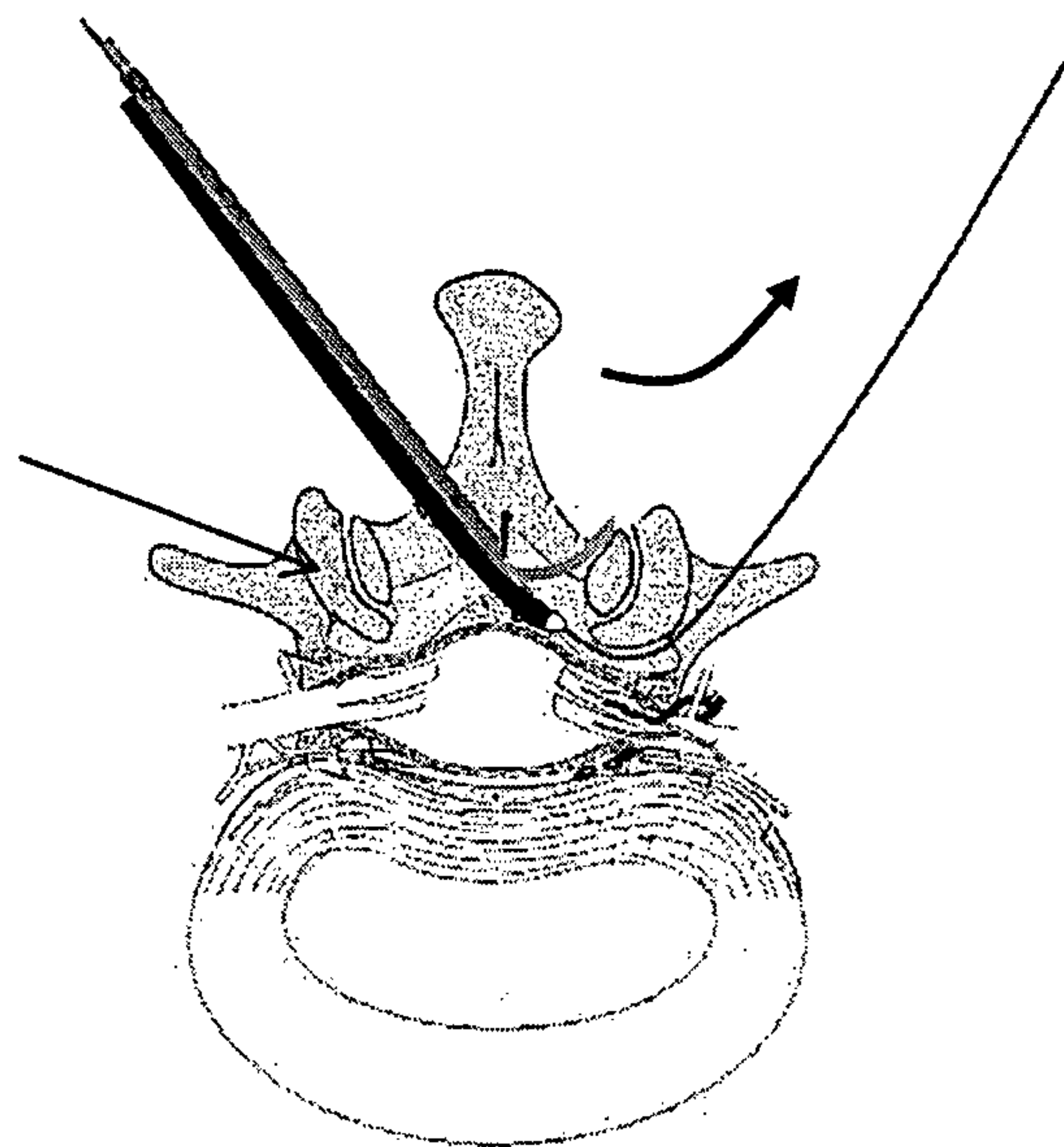

FIGURE 54

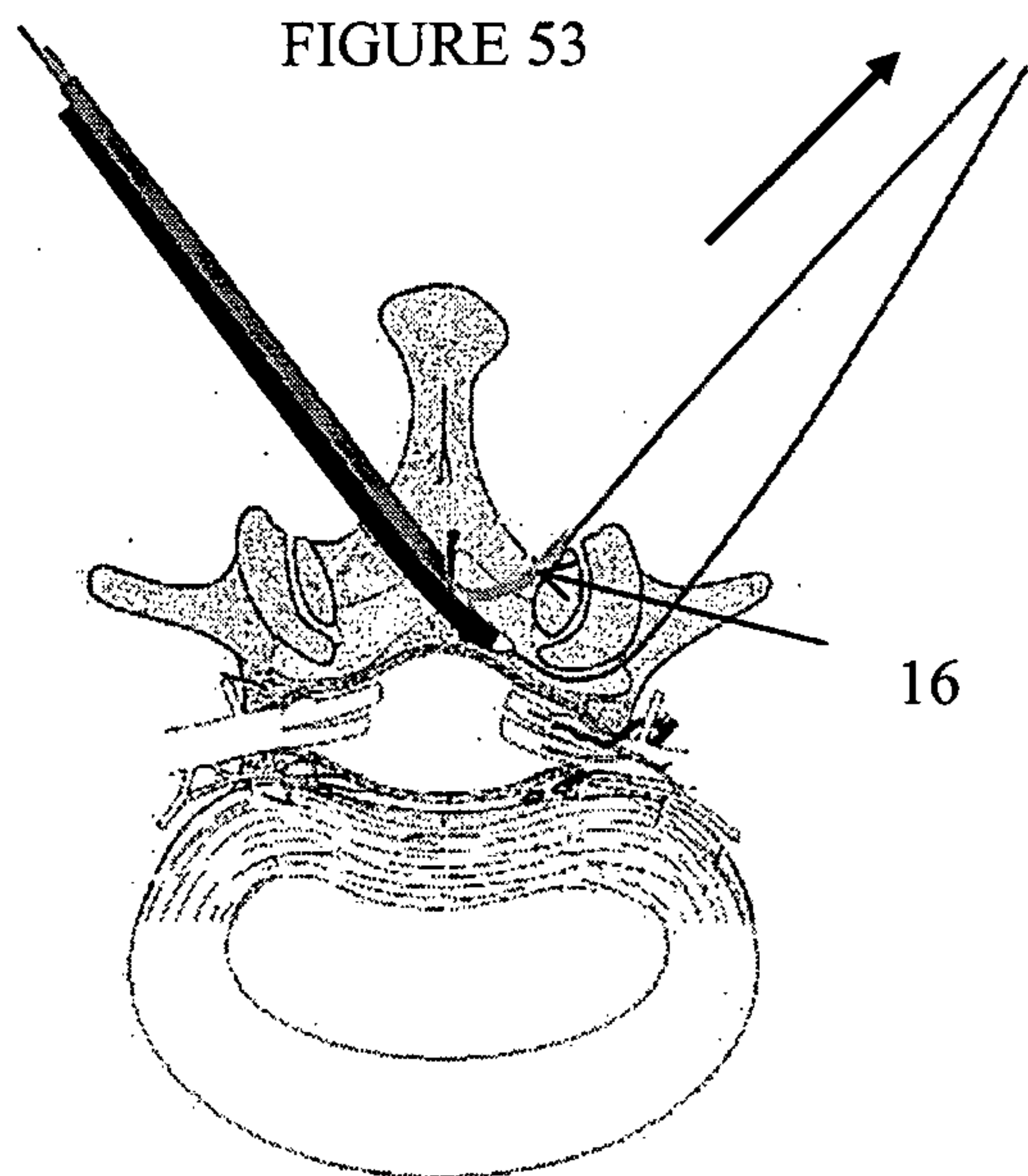

FIGURE 55

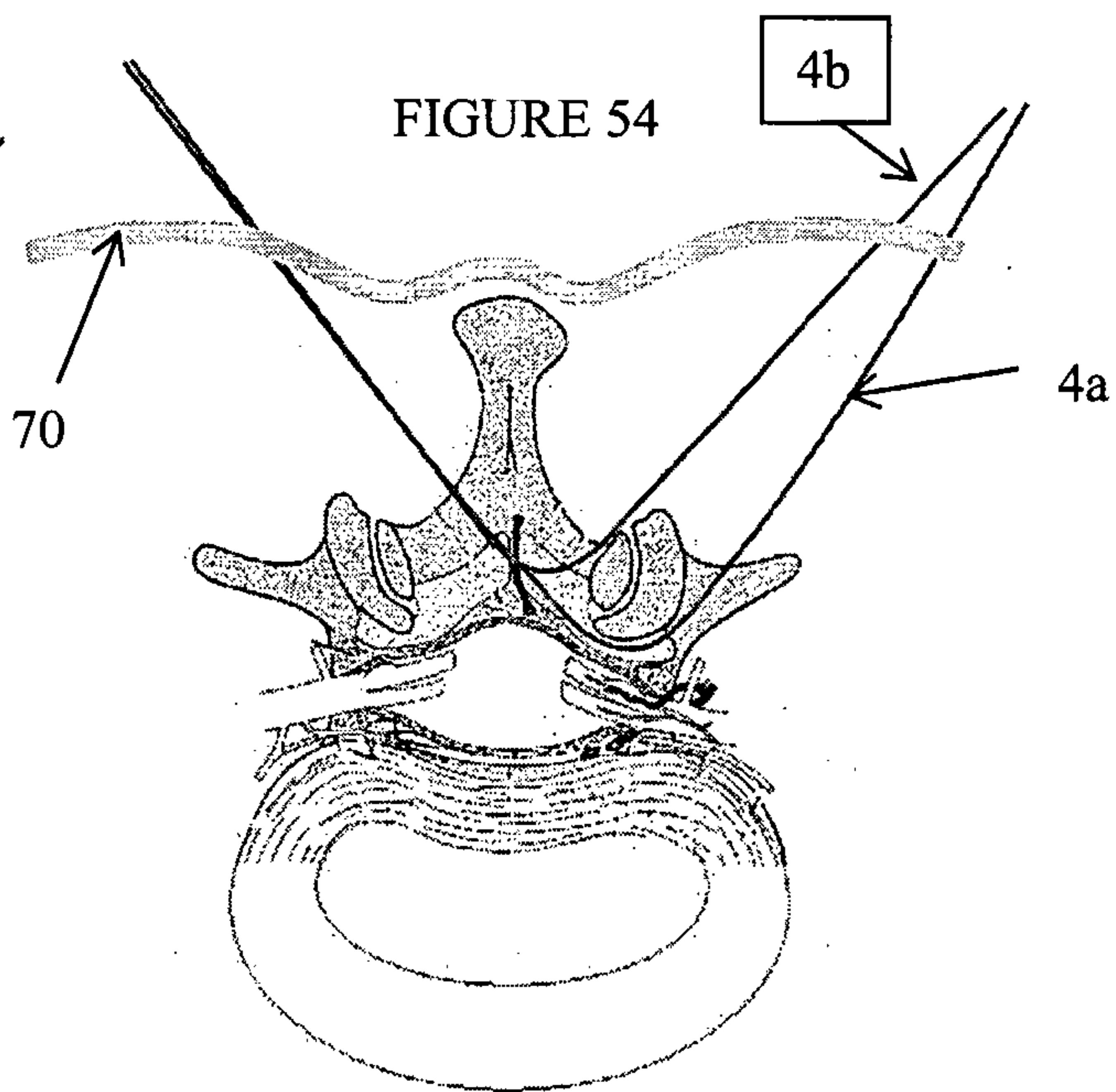

FIGURE 56



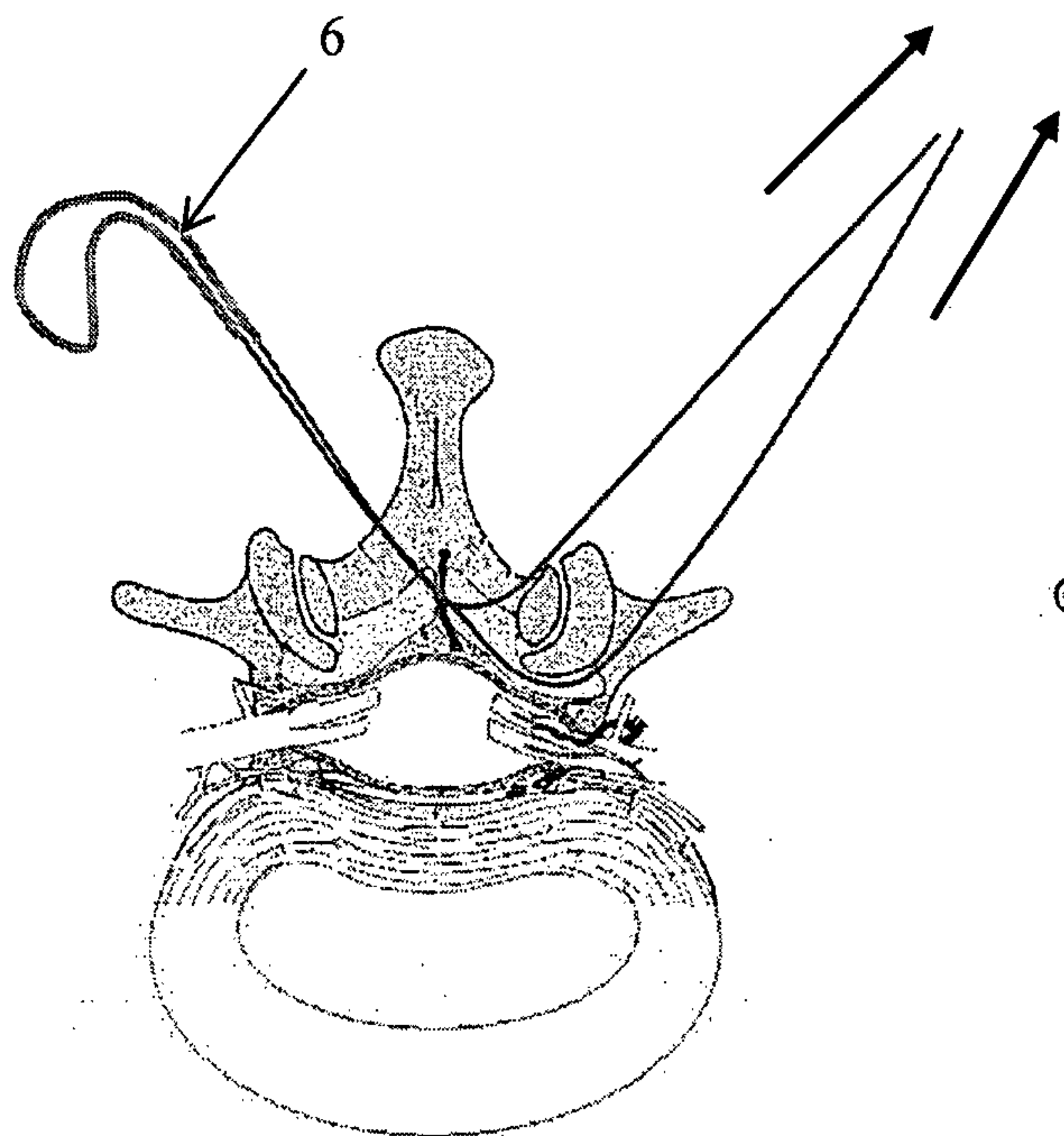

FIGURE 57

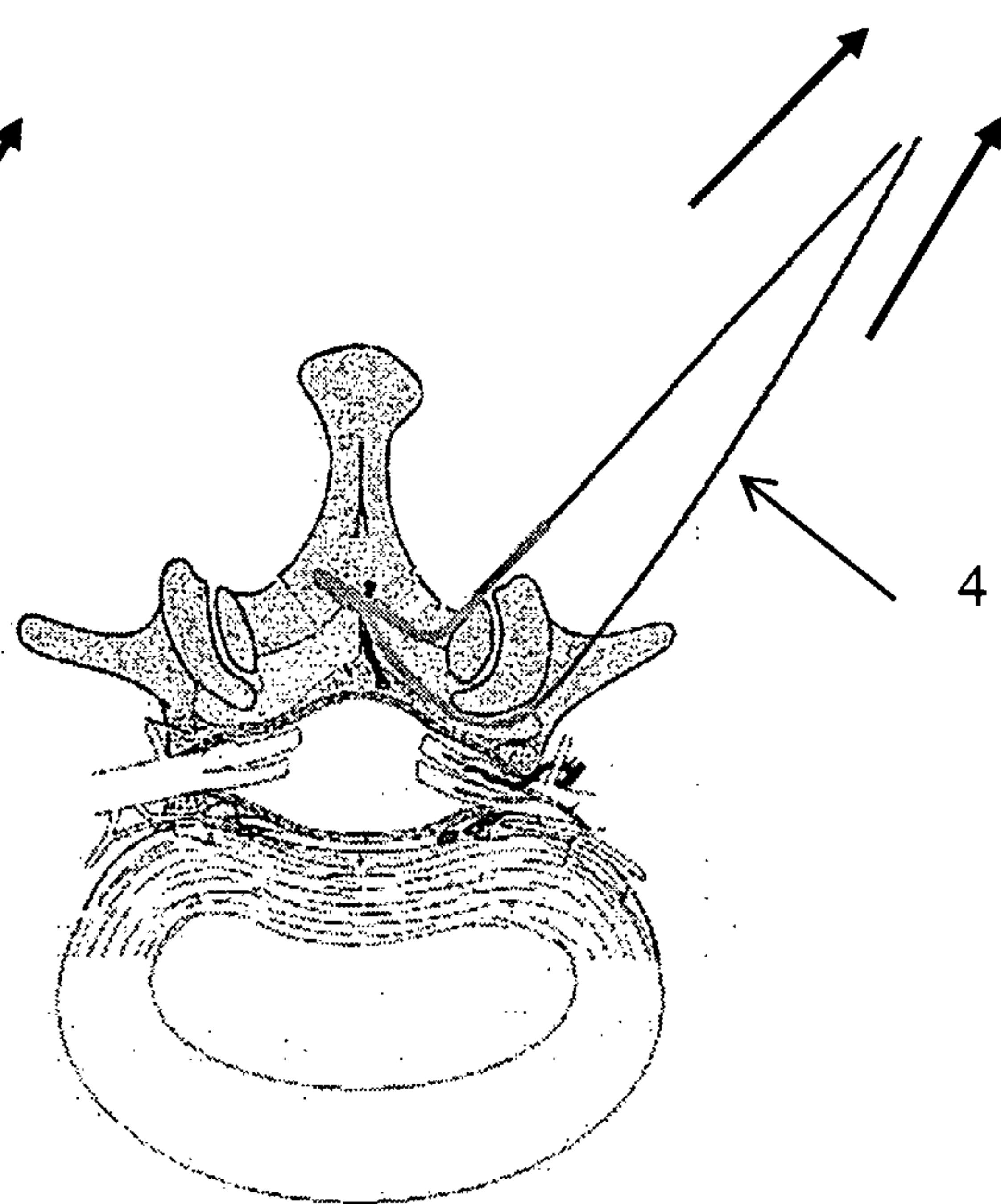

FIGURE 58

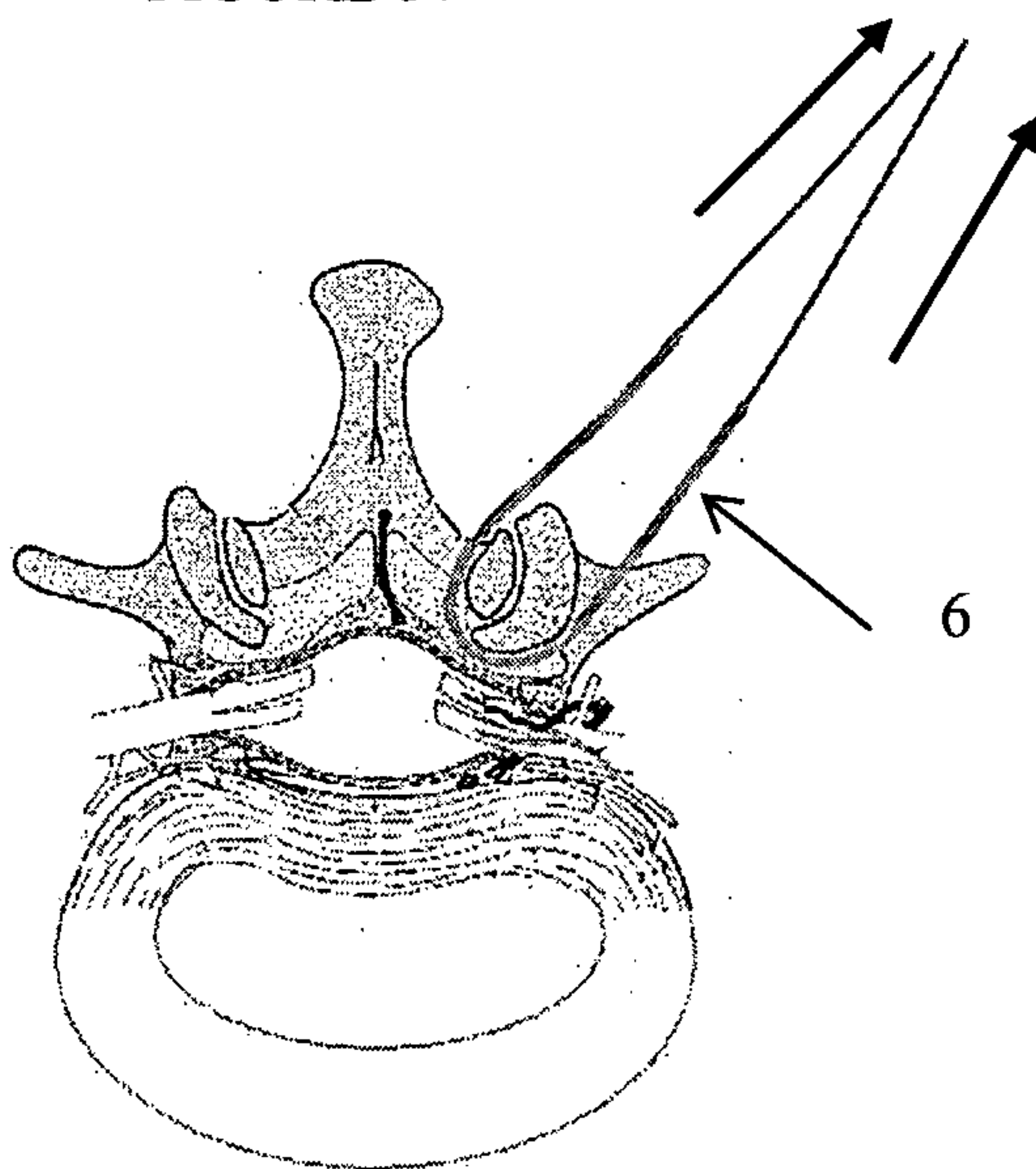

FIGURE 59

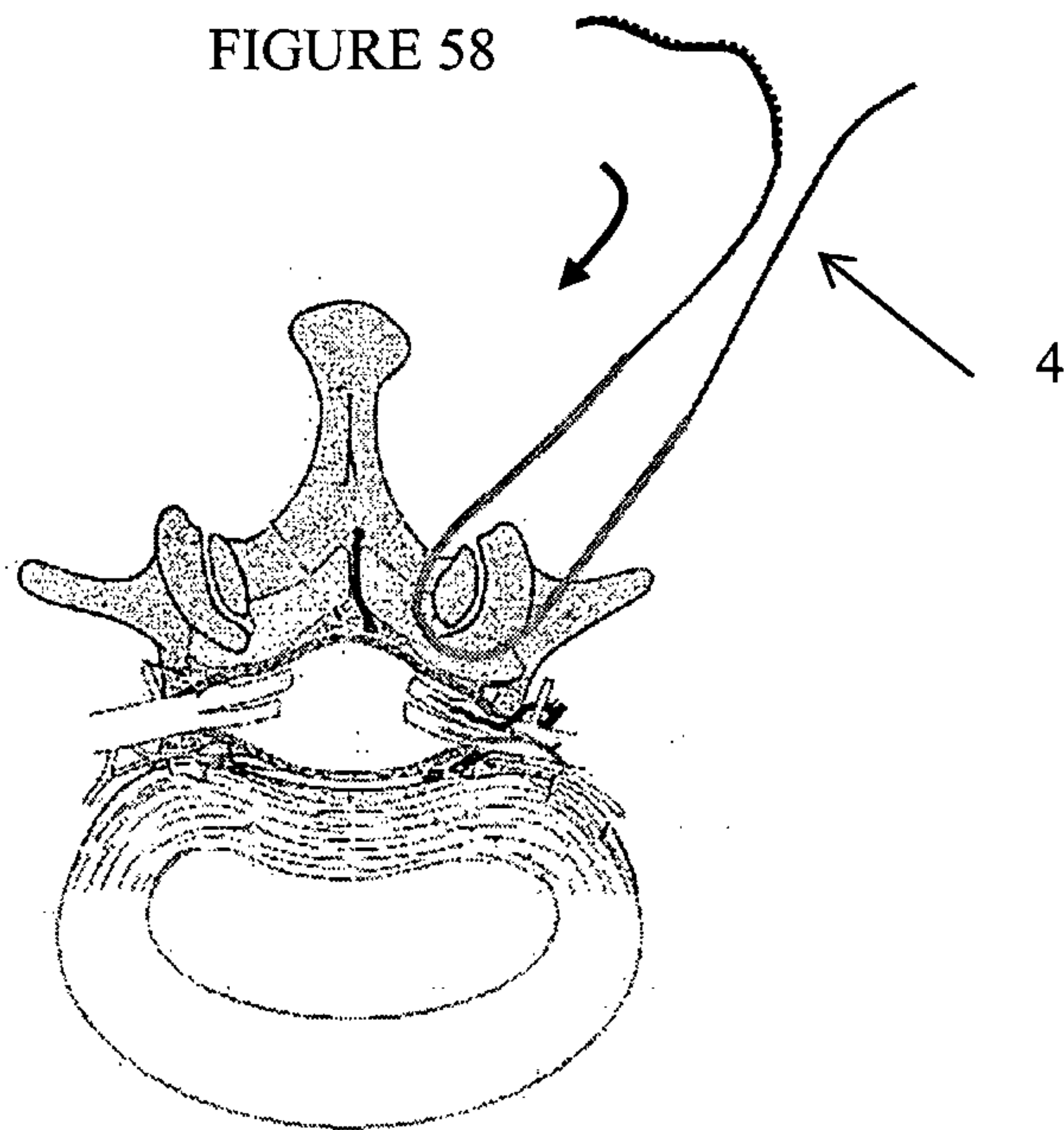

FIGURE 60

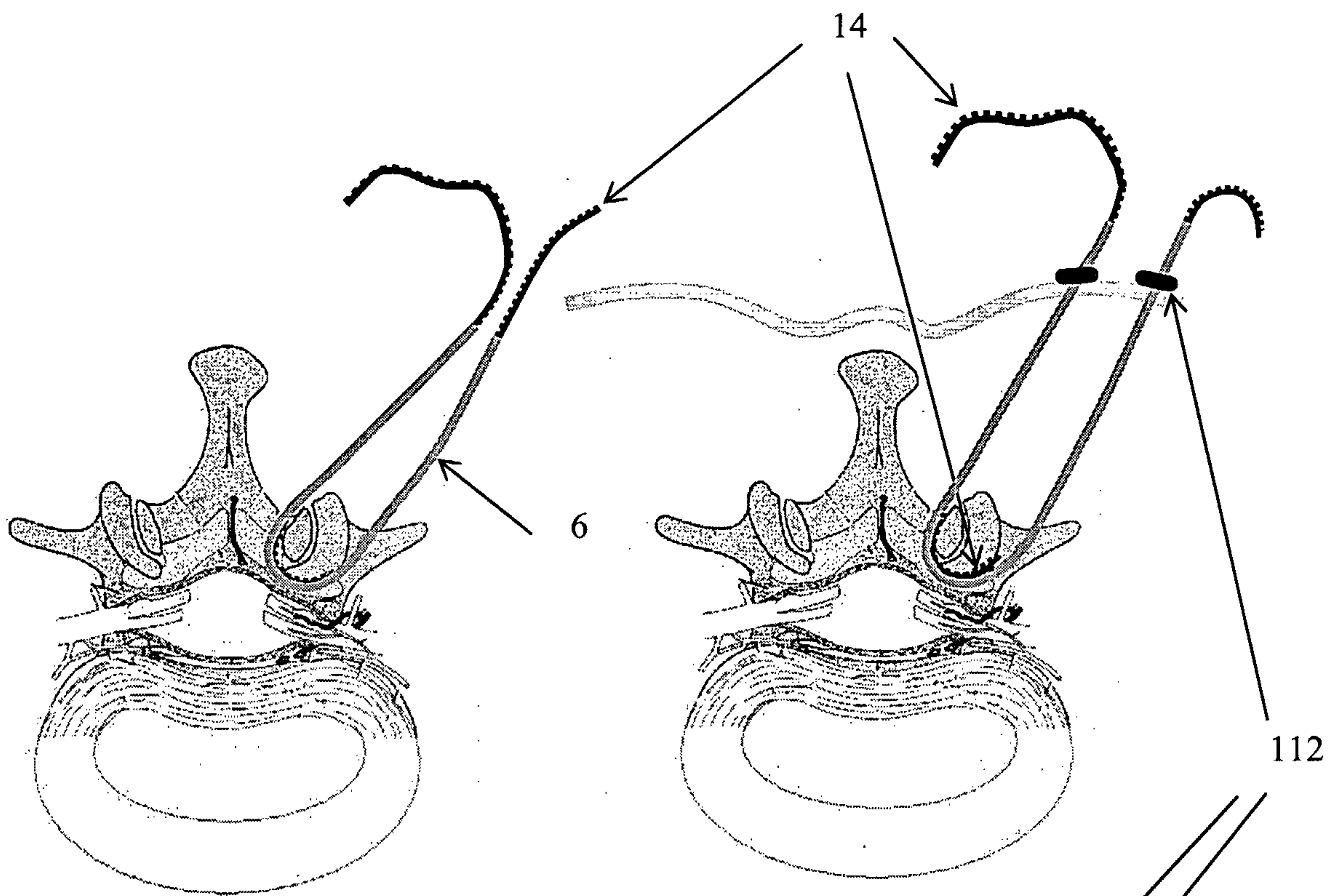

FIGURE 61

FIGURE 62

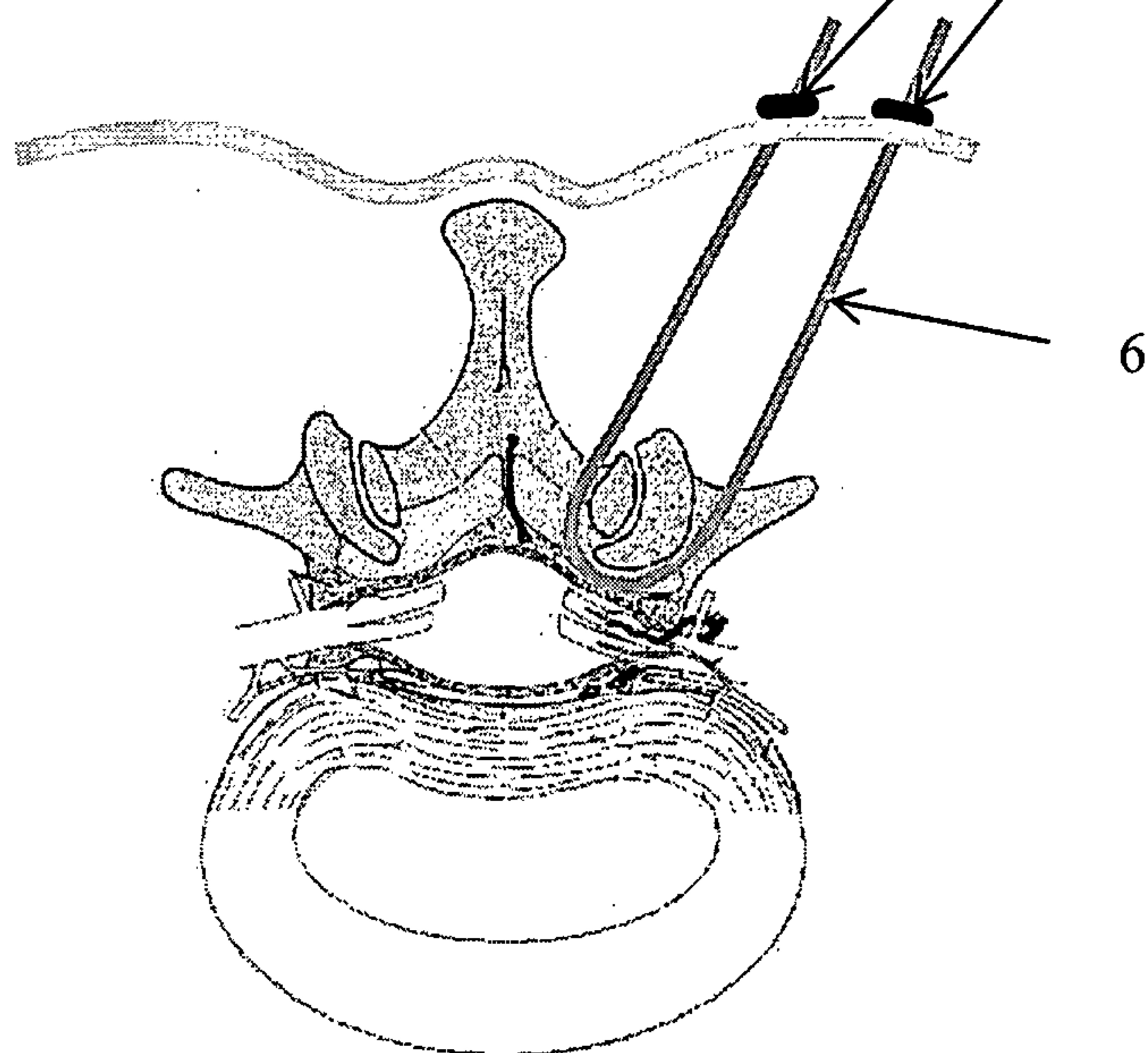

FIGURE 63



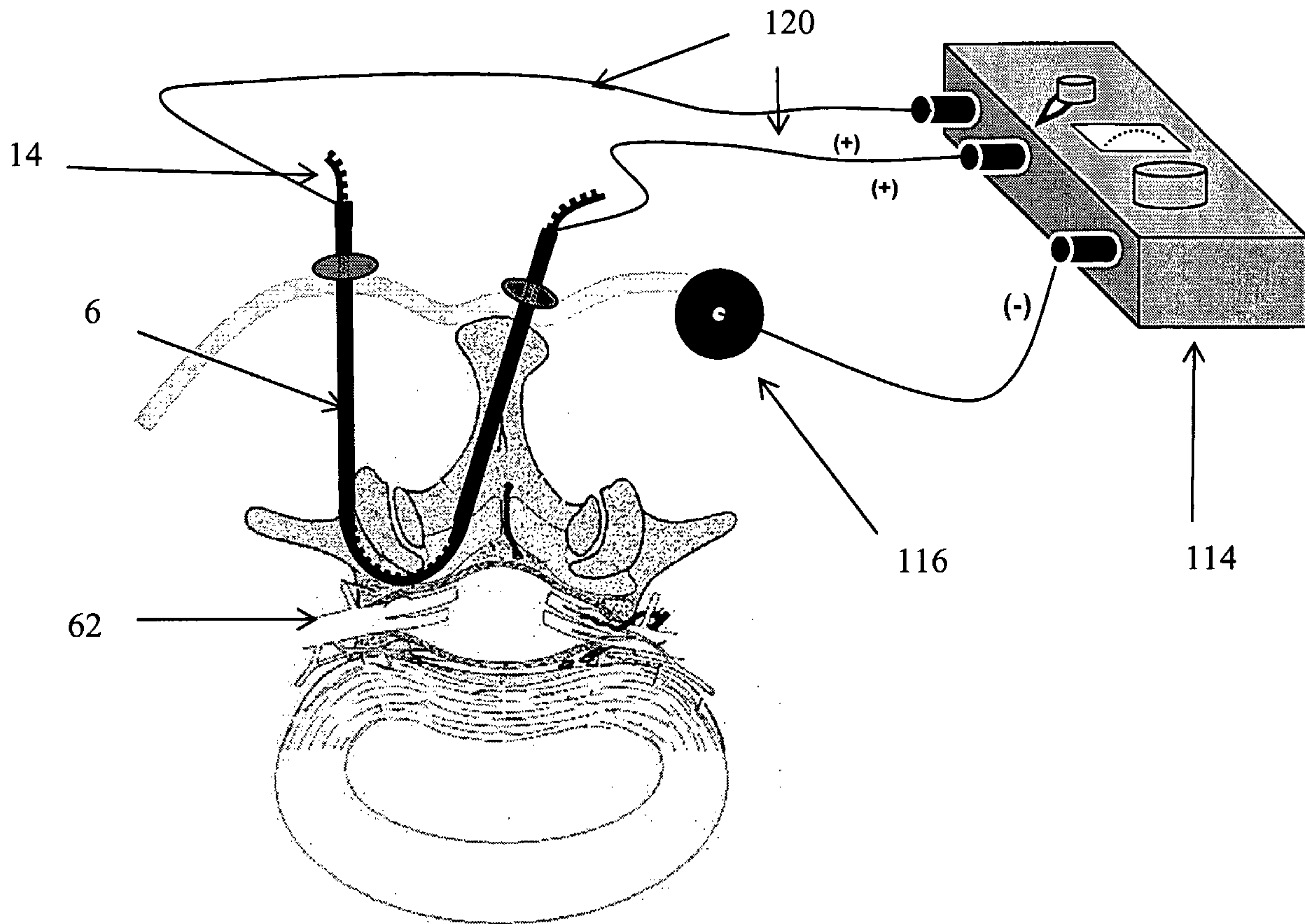

FIGURE 64

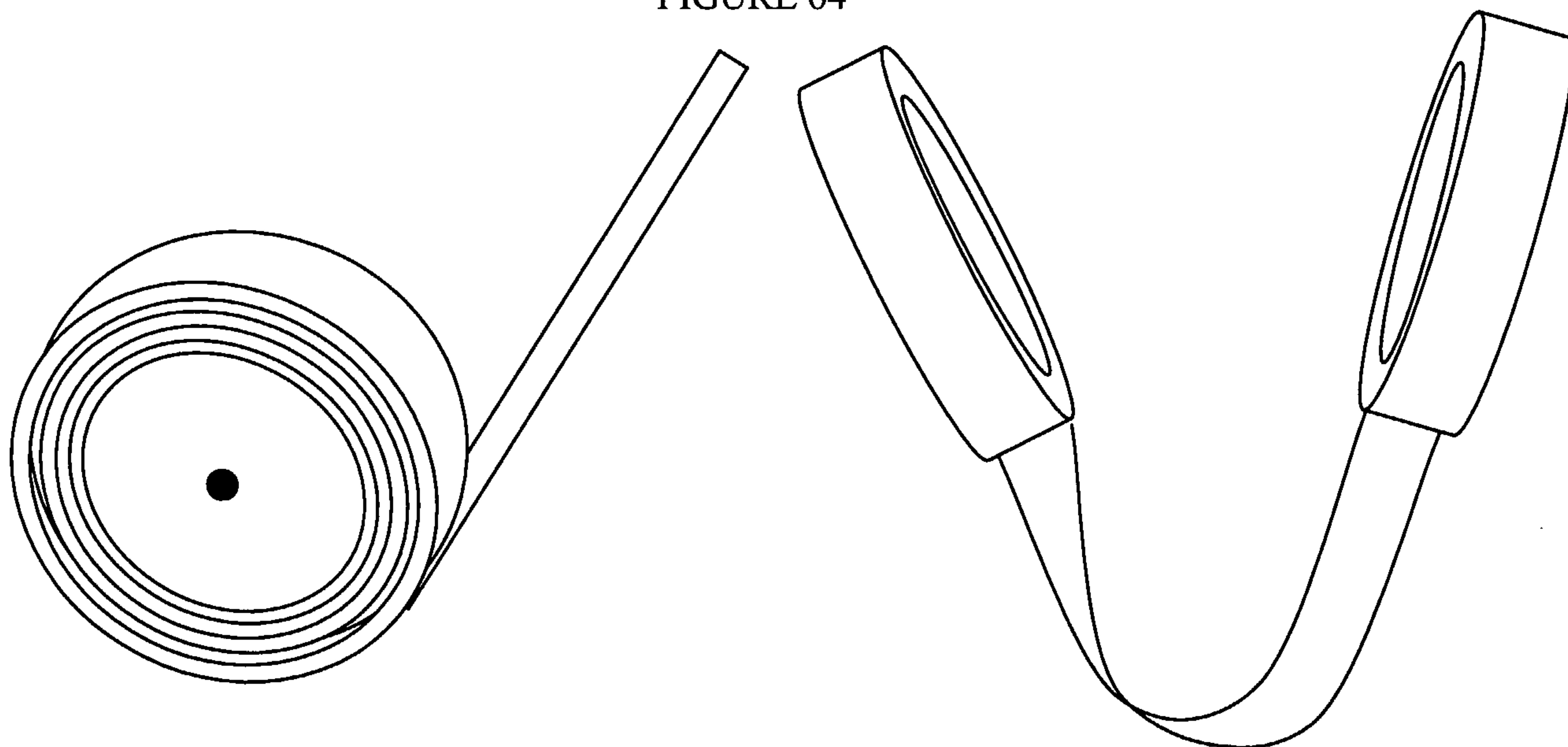

FIGURE 65a

FIGURE 65b

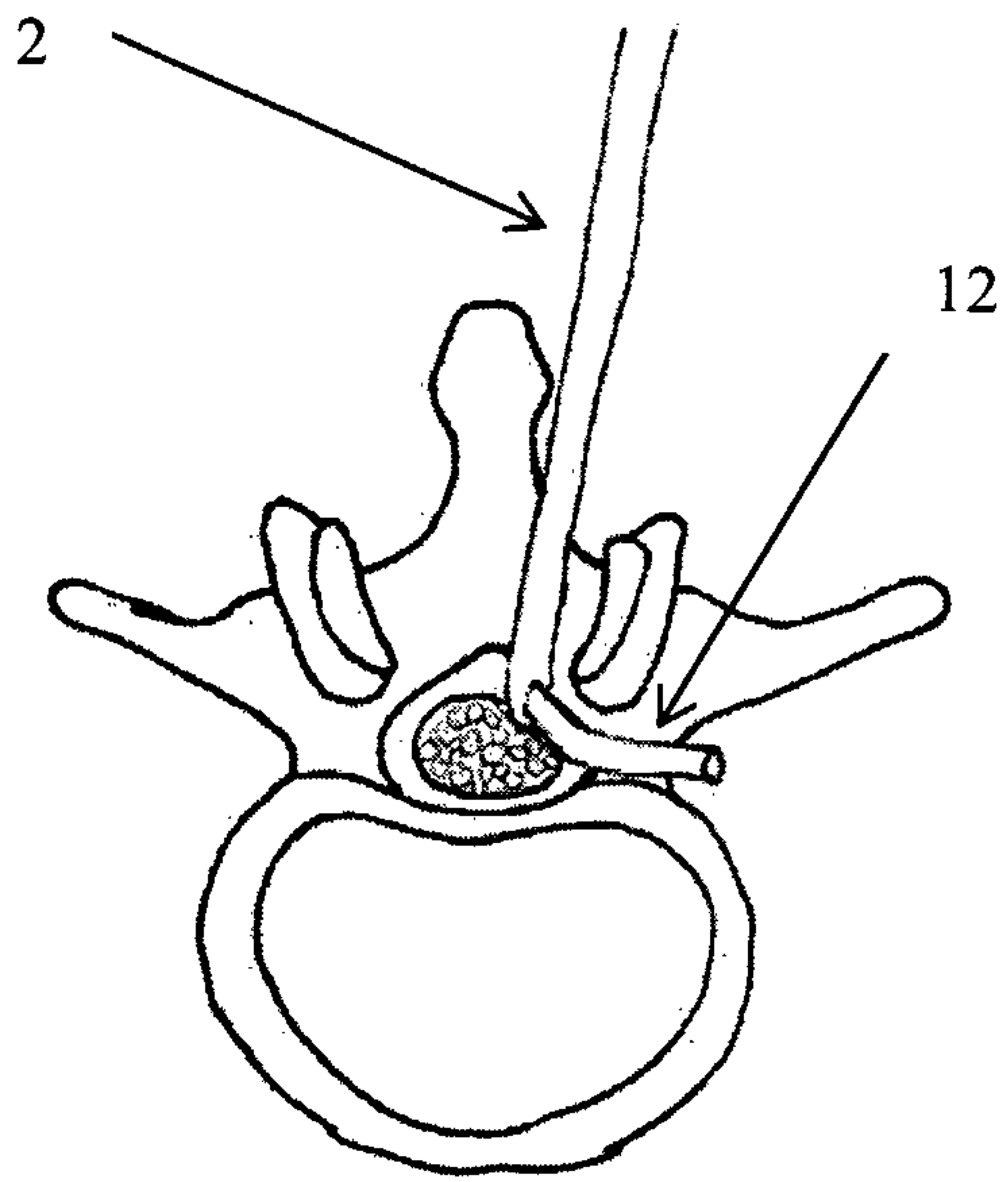

FIGURE 66

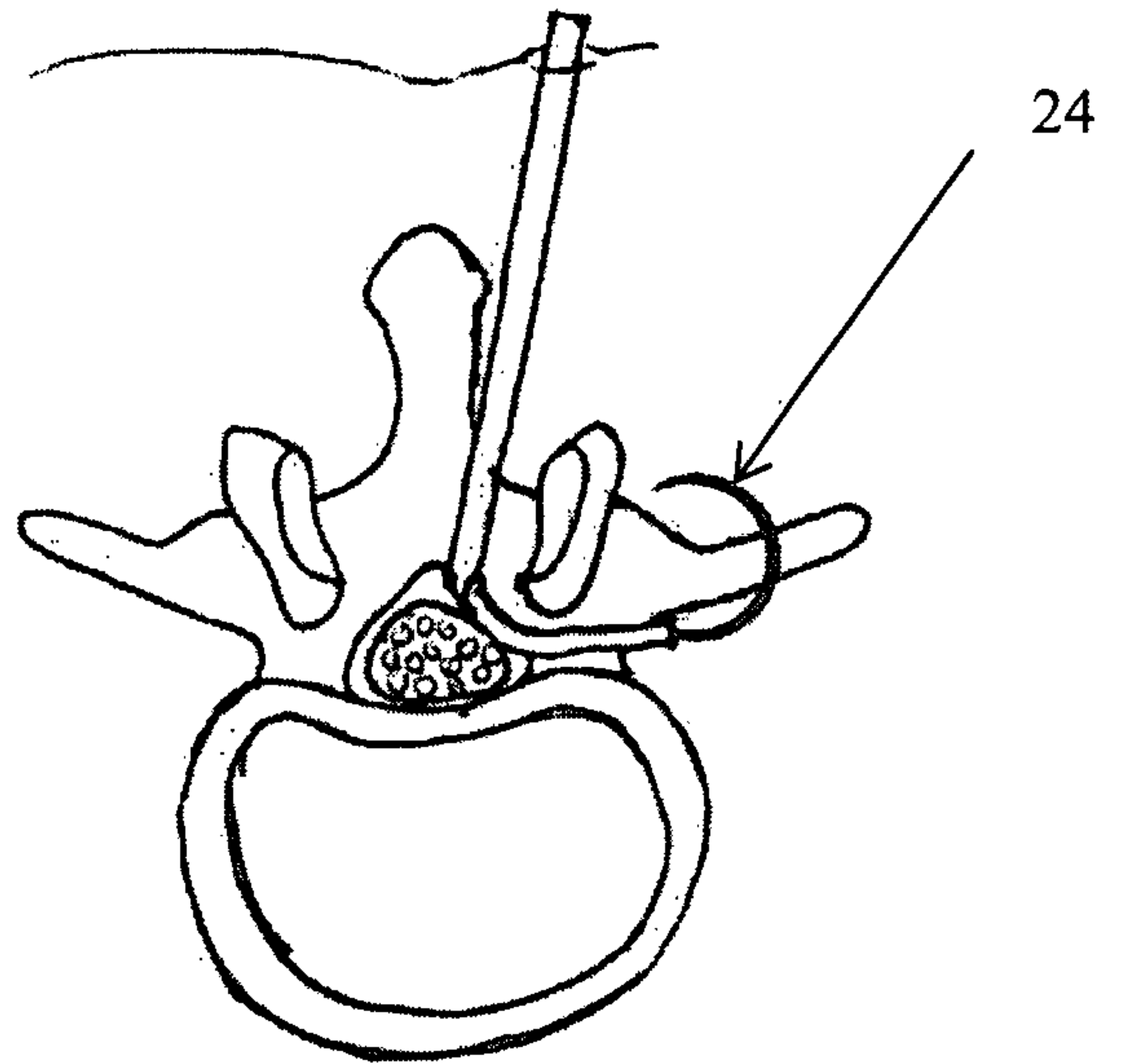

FIGURE 67

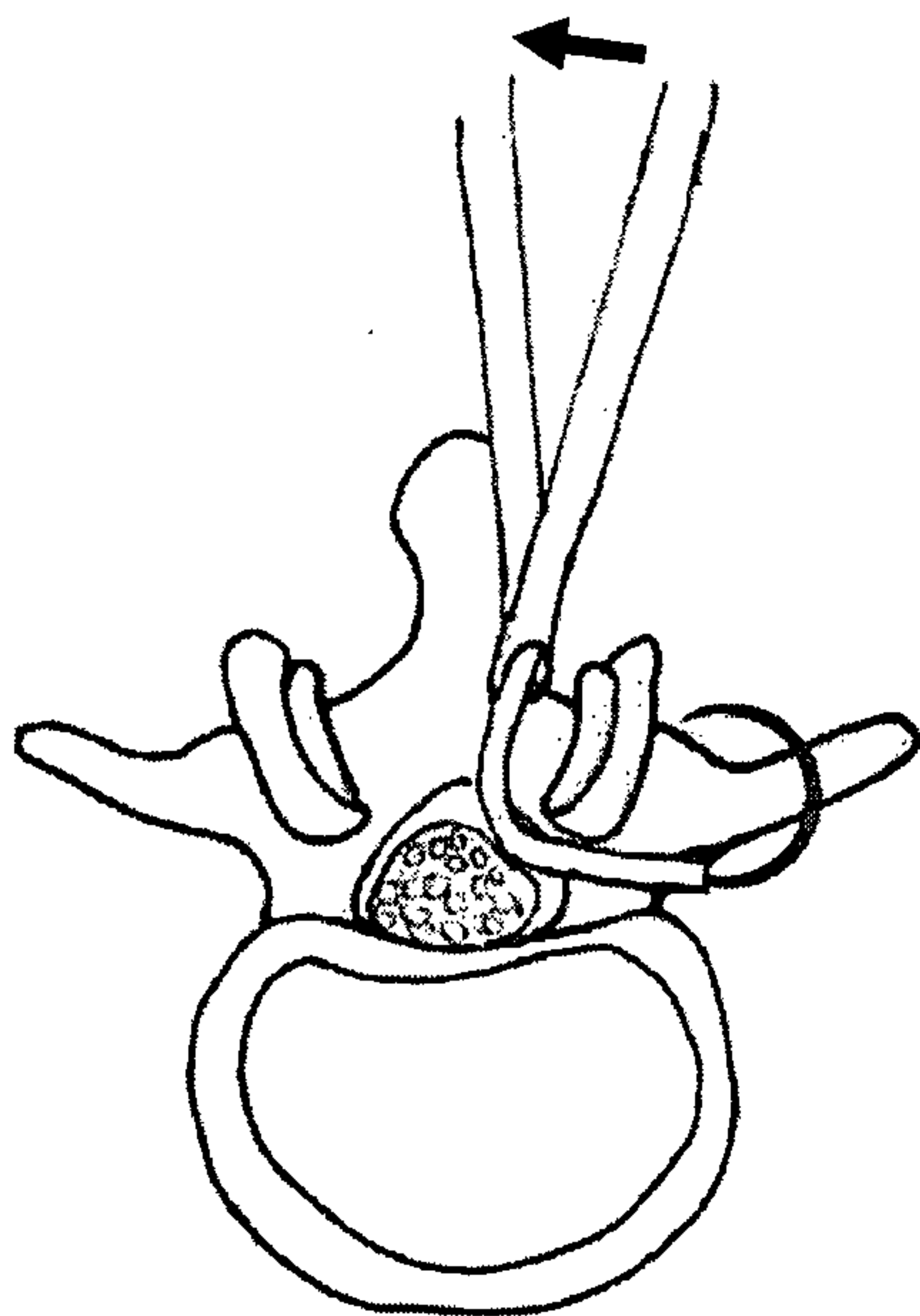

FIGURE 68

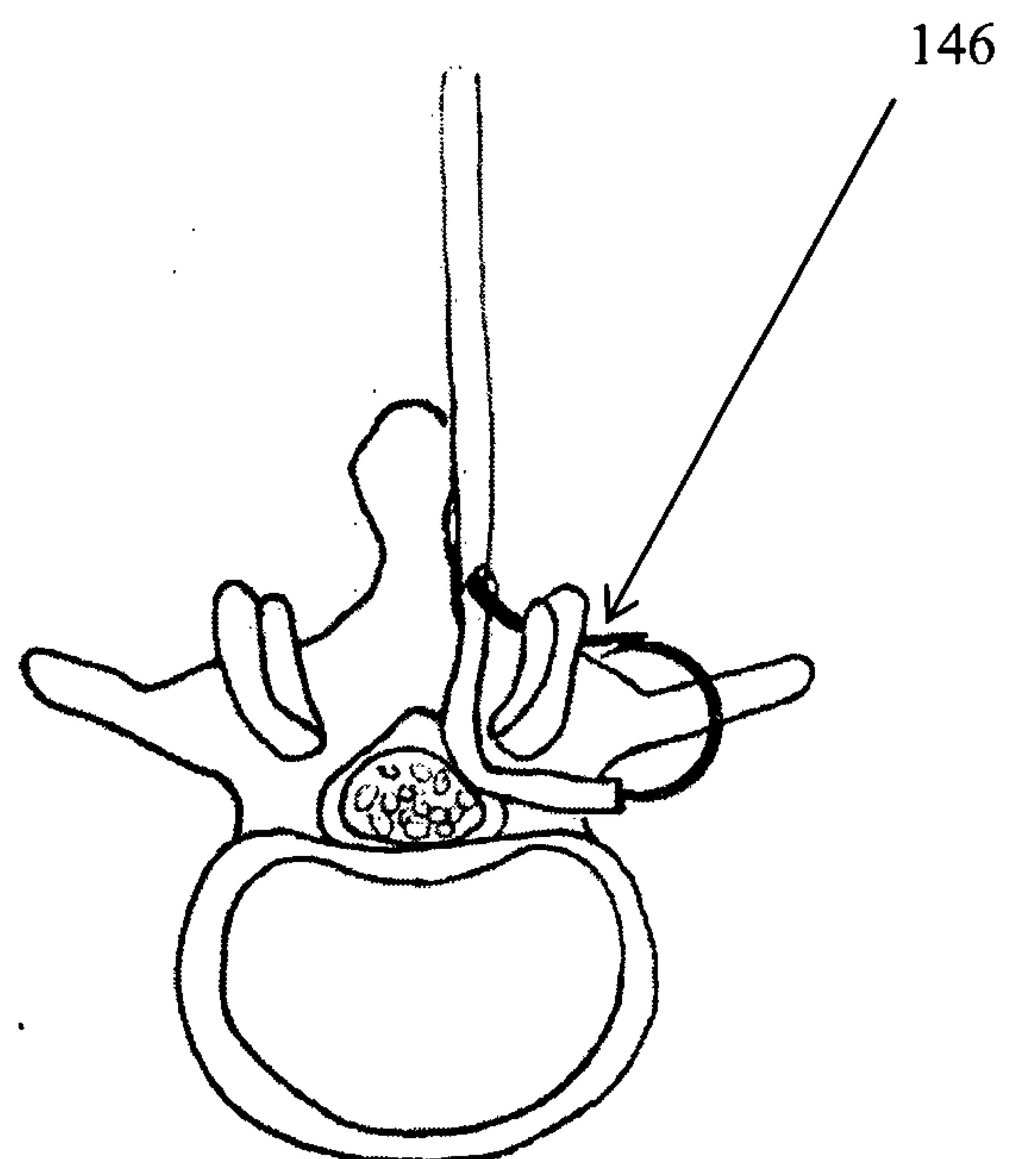

FIGURE 69



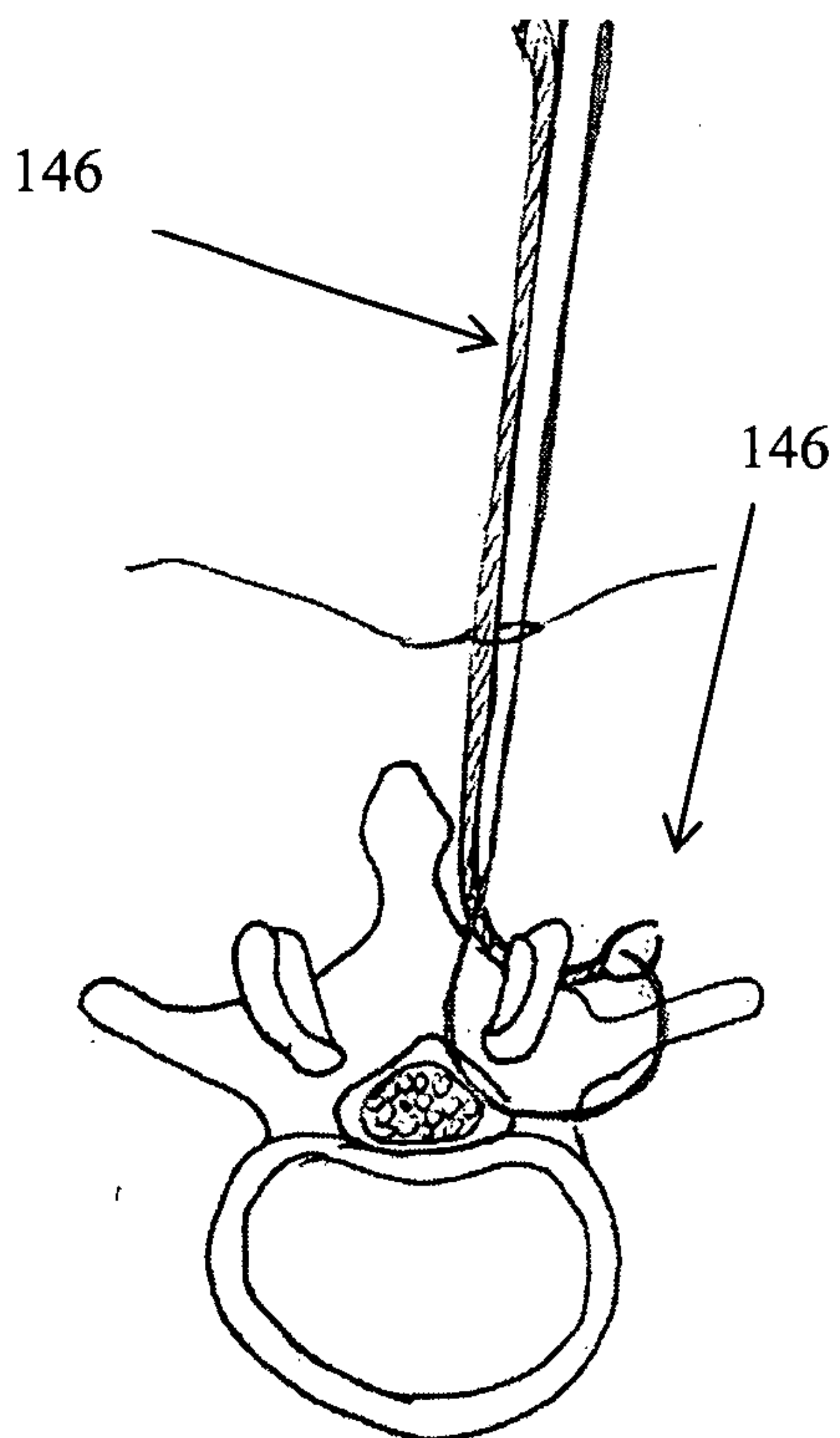

FIGURE 70

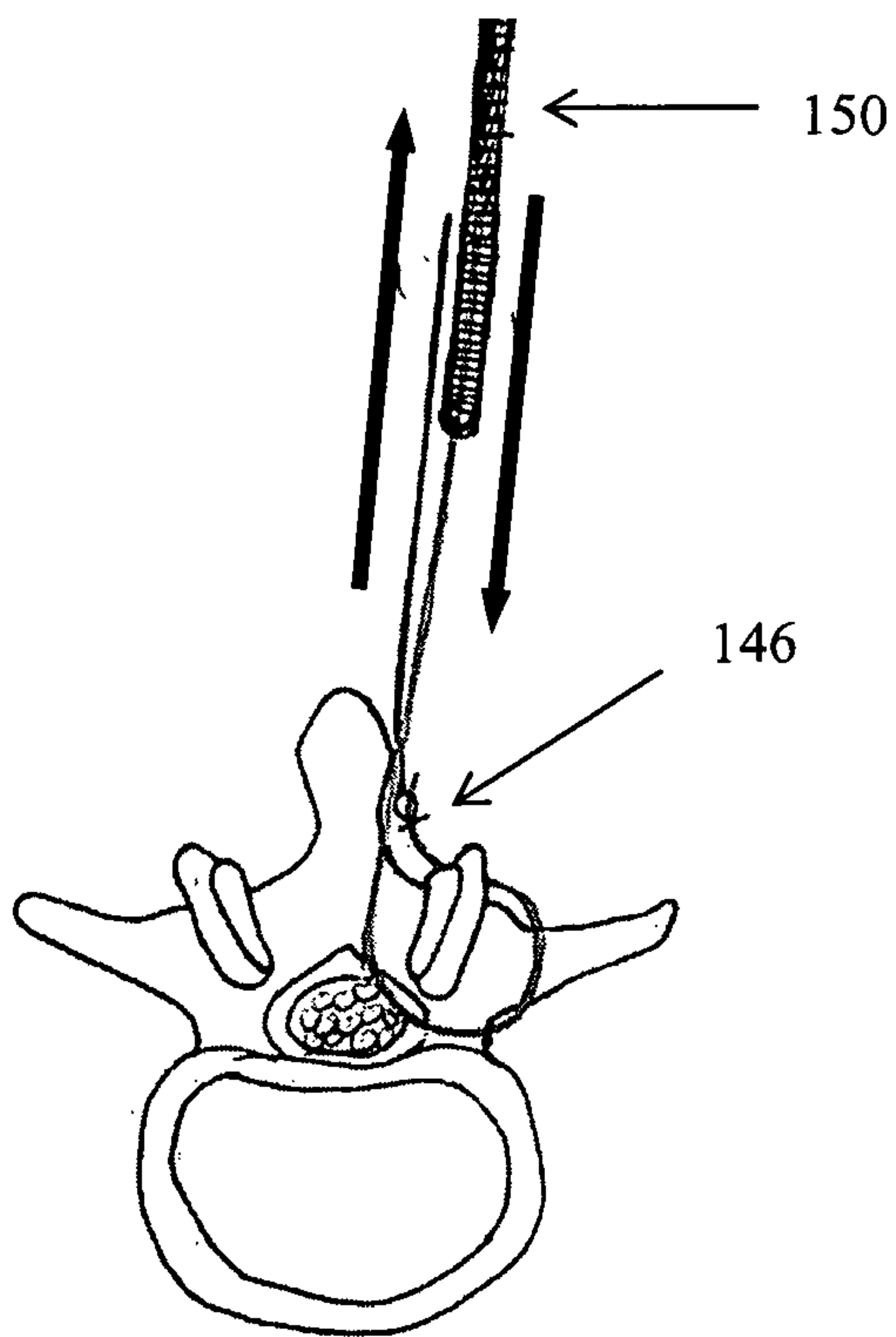

FIGURE 71

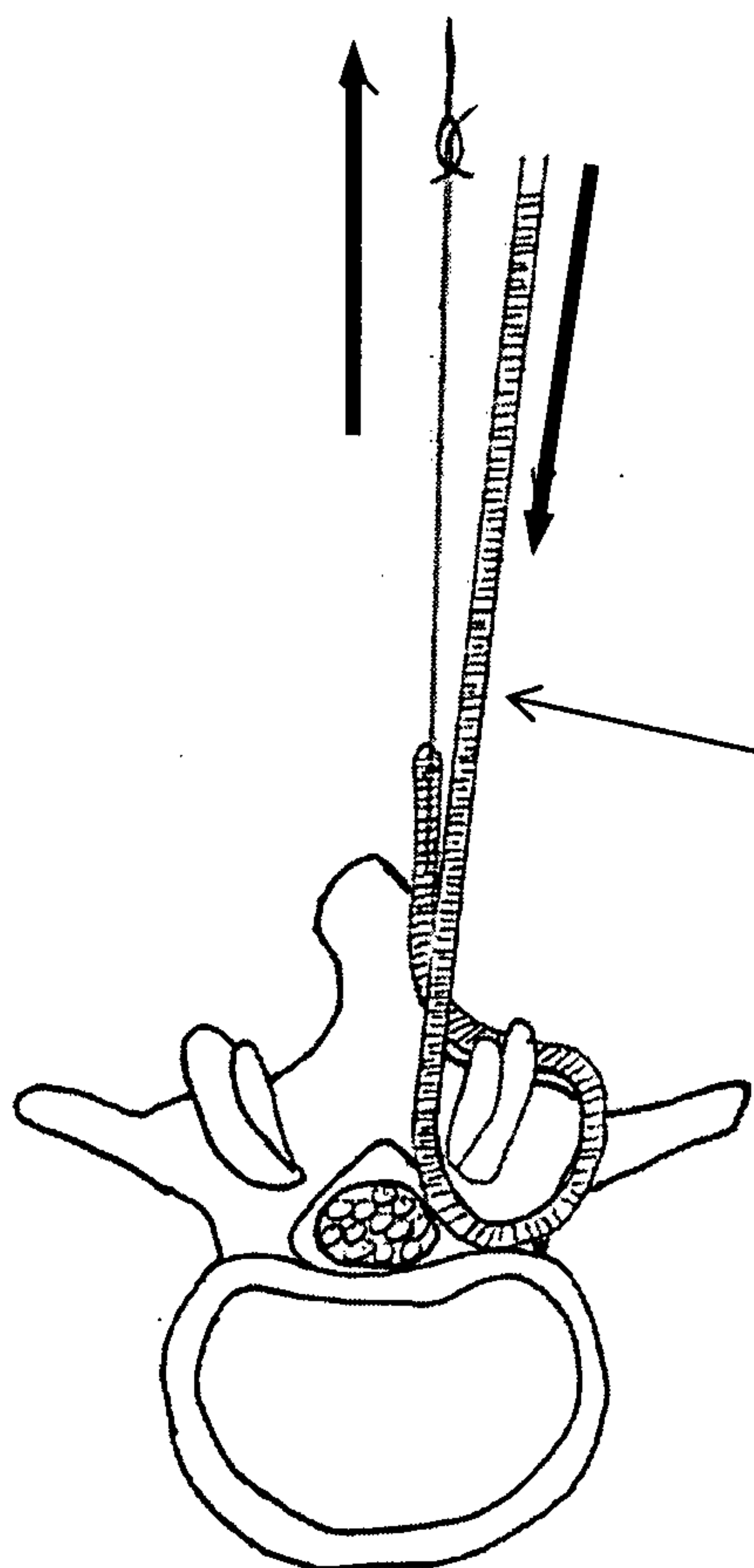

FIGURE 72

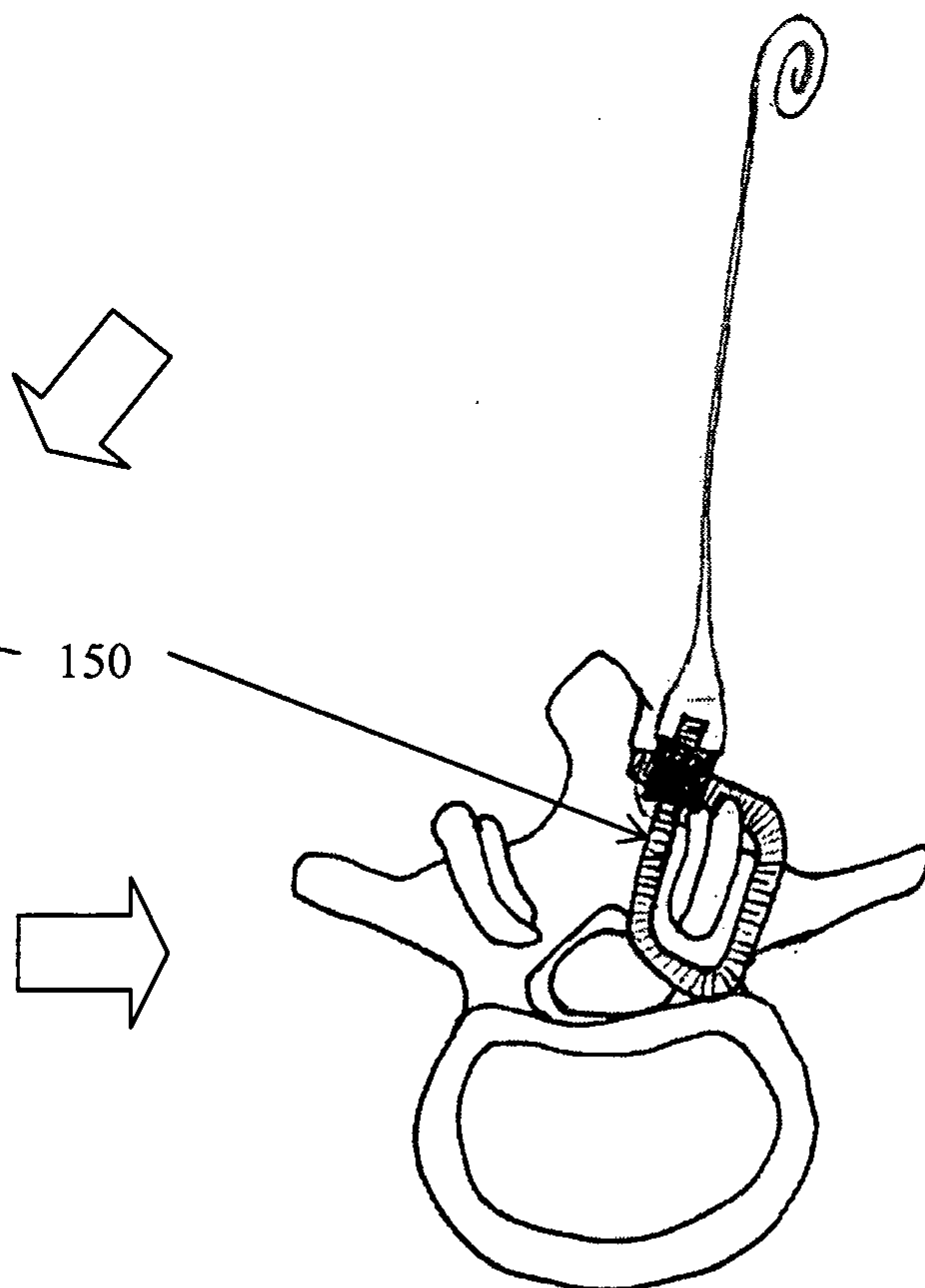

FIGURE 73

FIGURE 74a

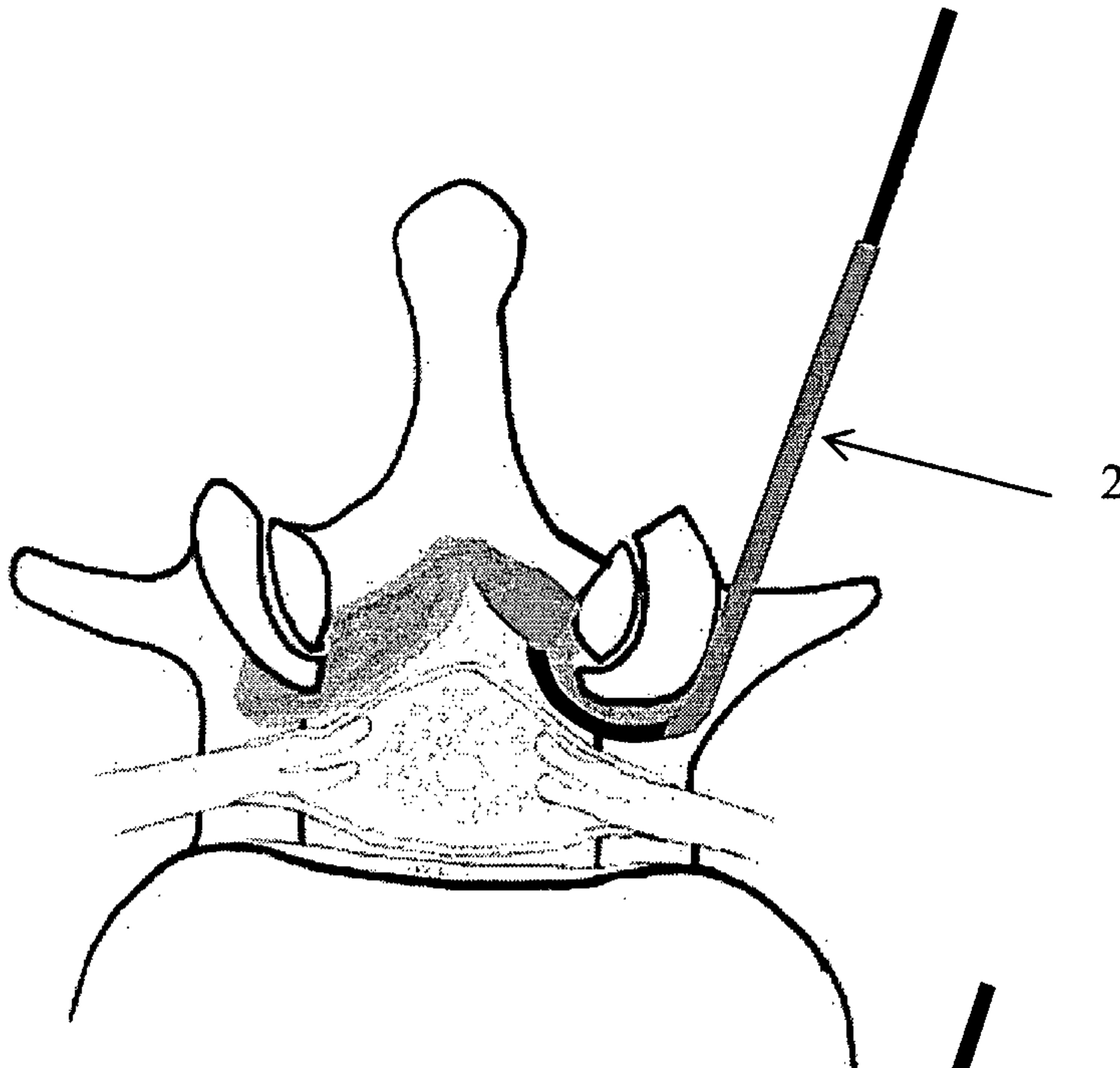

FIGURE 74b

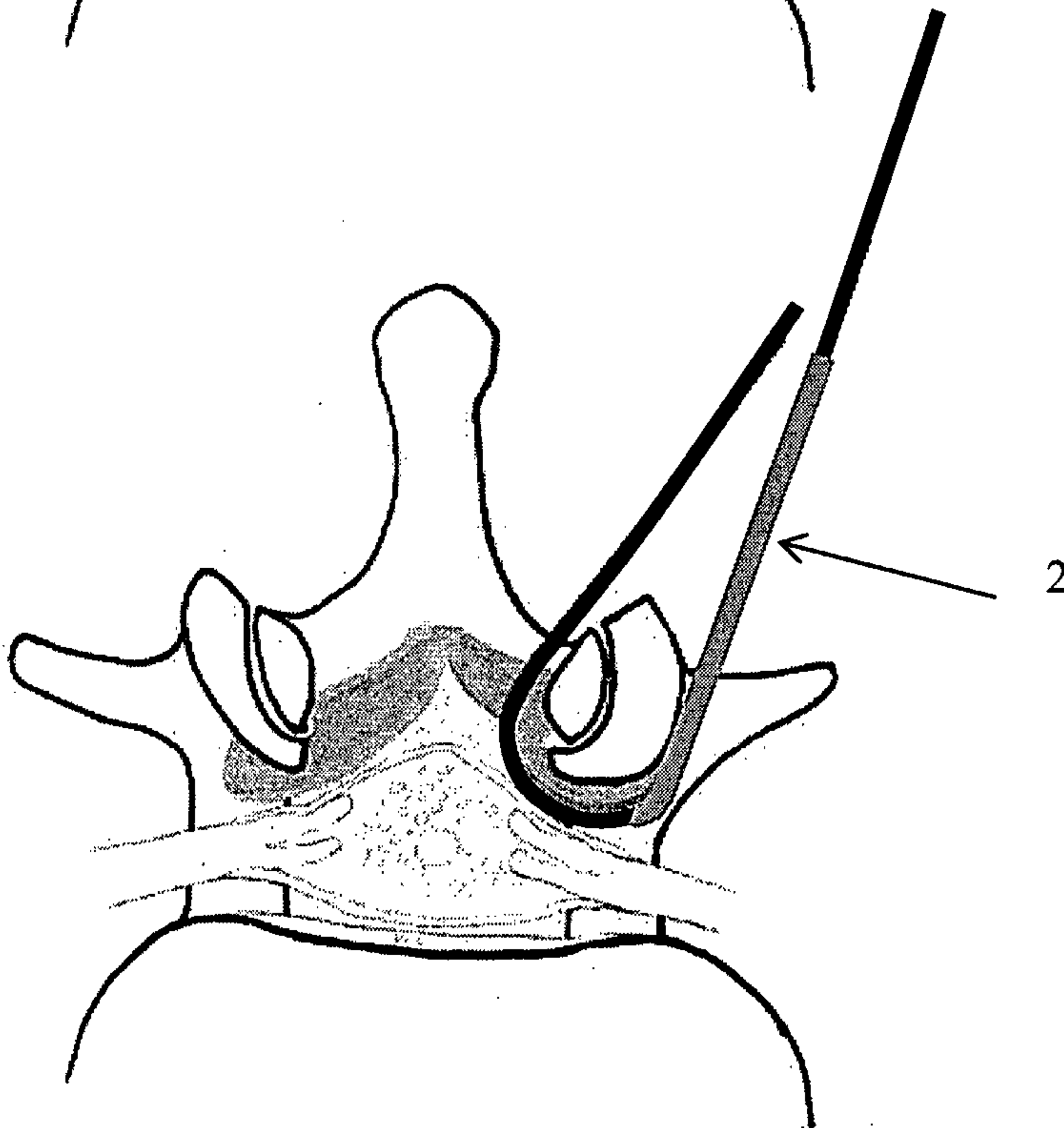



FIGURE 75a

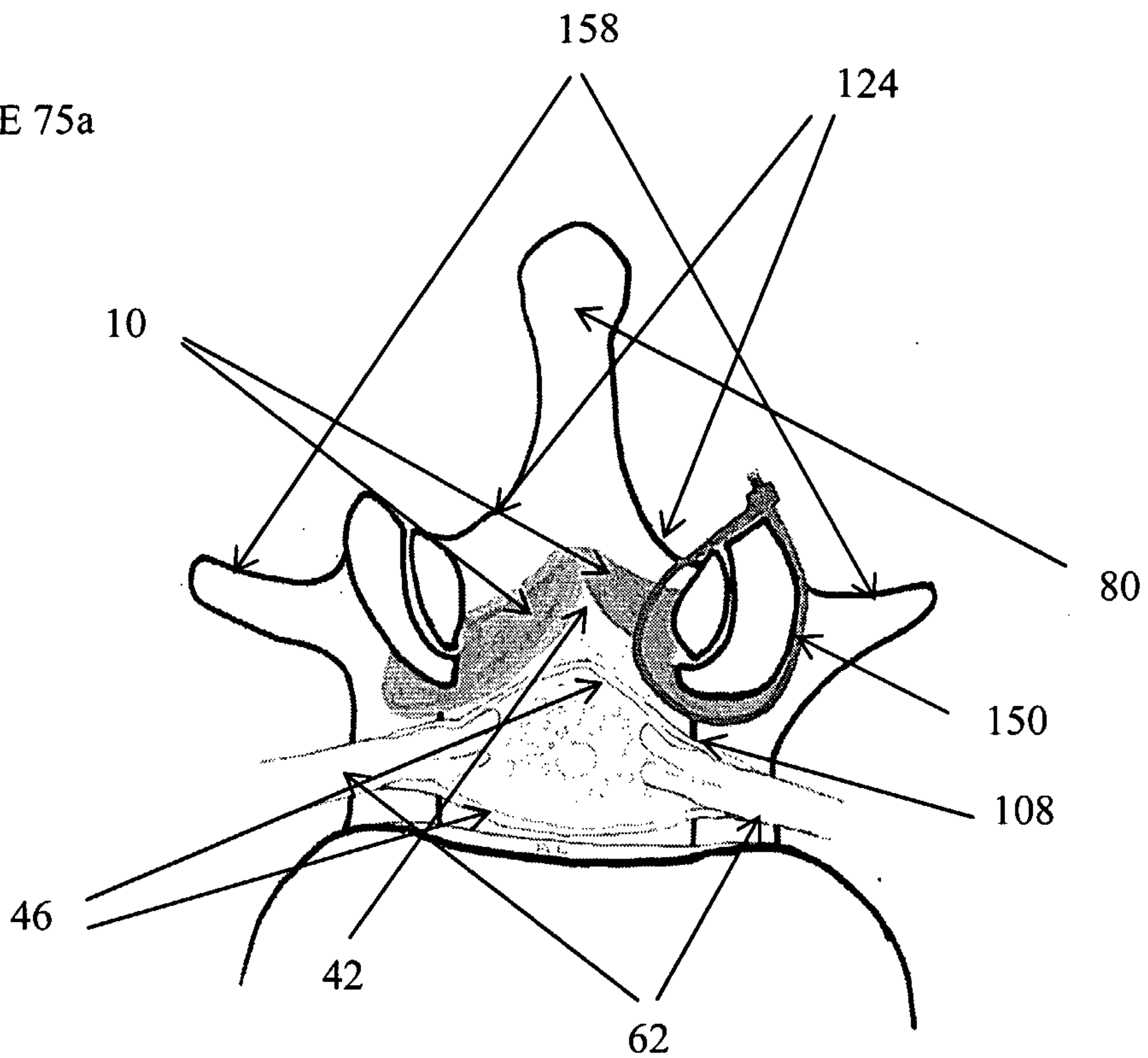

FIGURE 75b

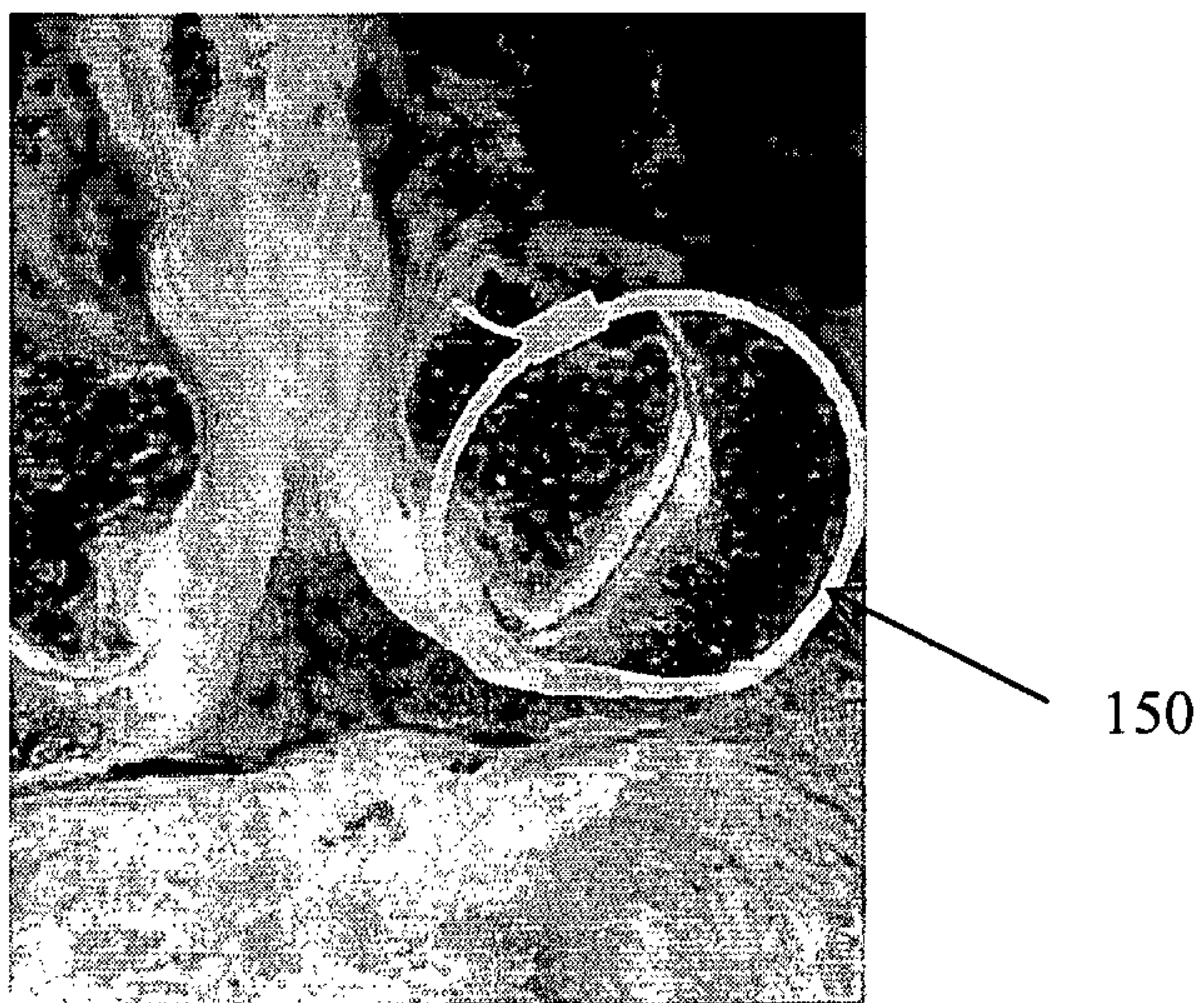

FIGURE 76

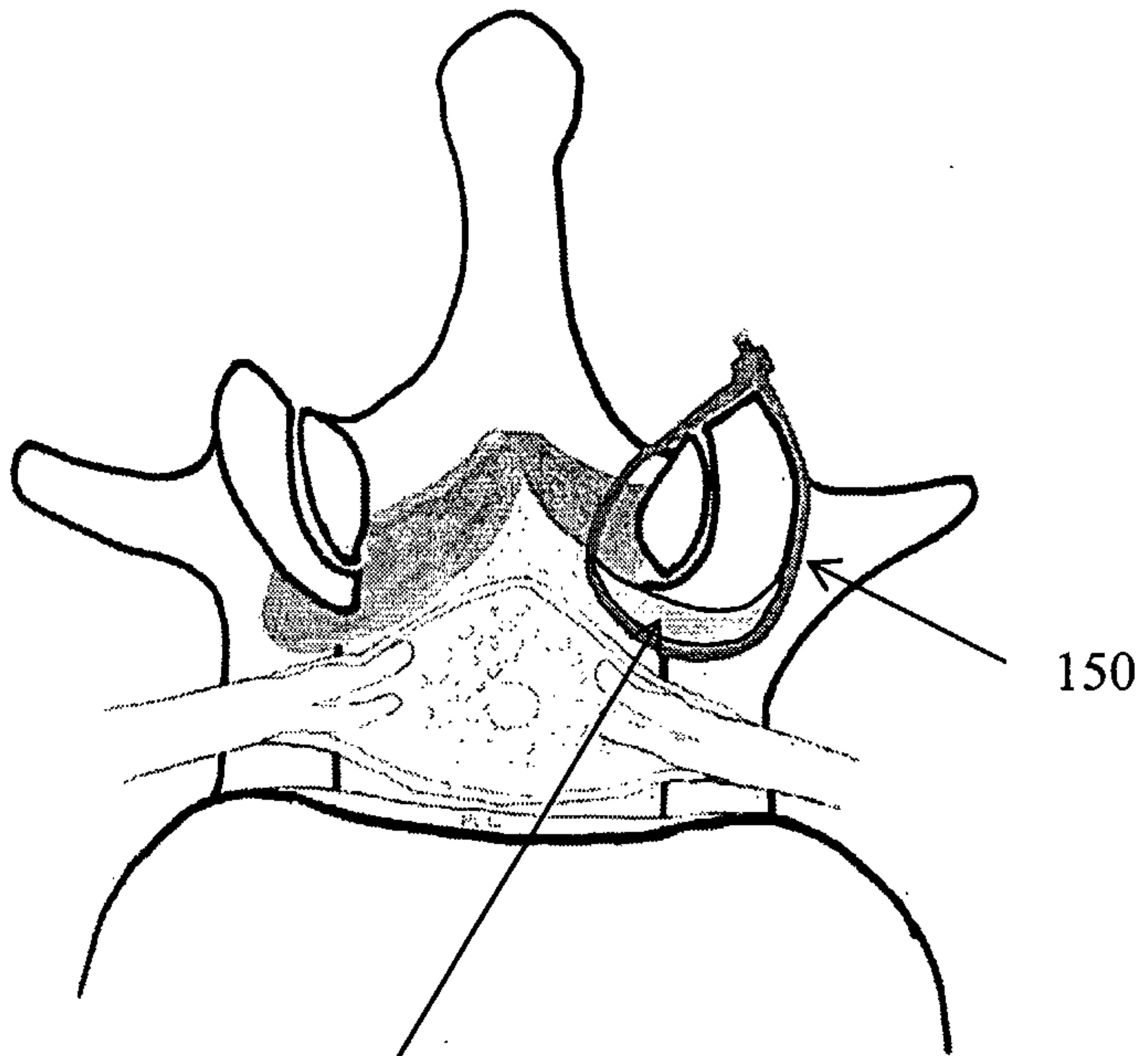
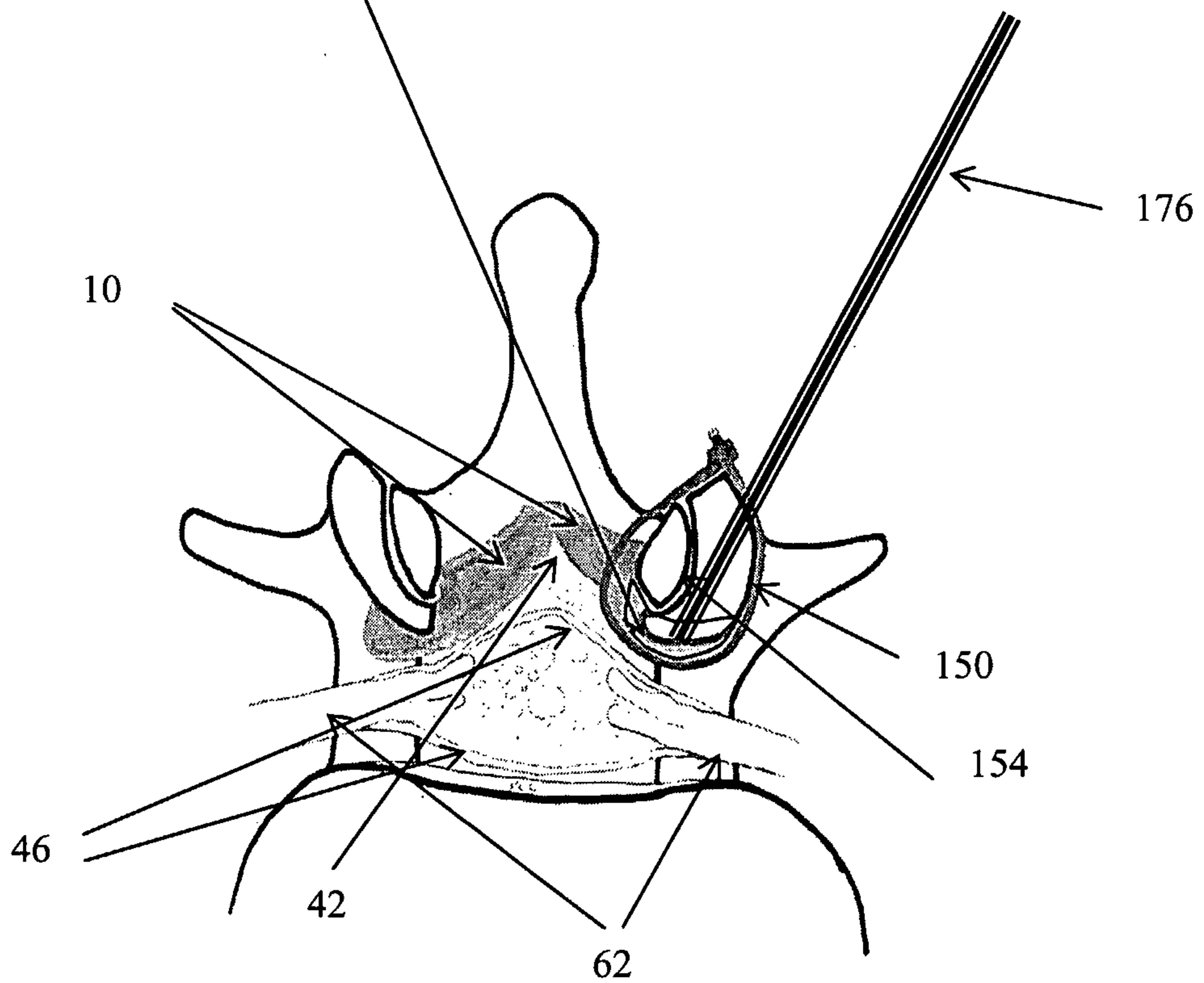

FIGURE 77





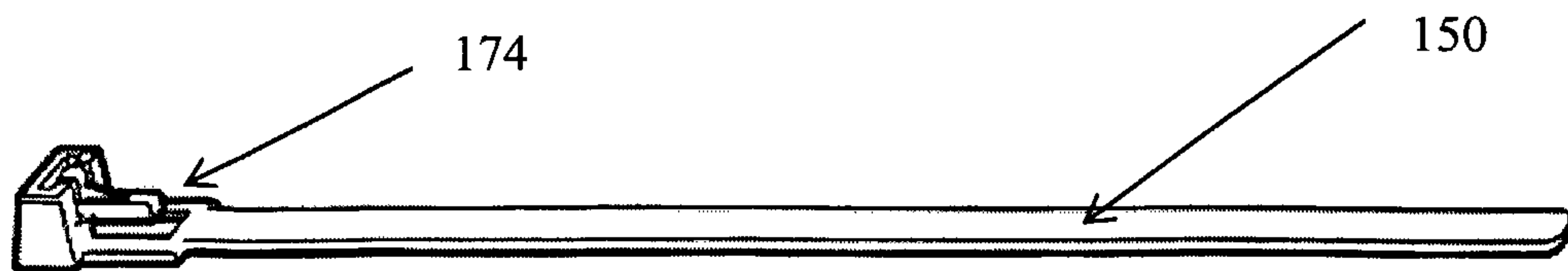

FIGURE 78

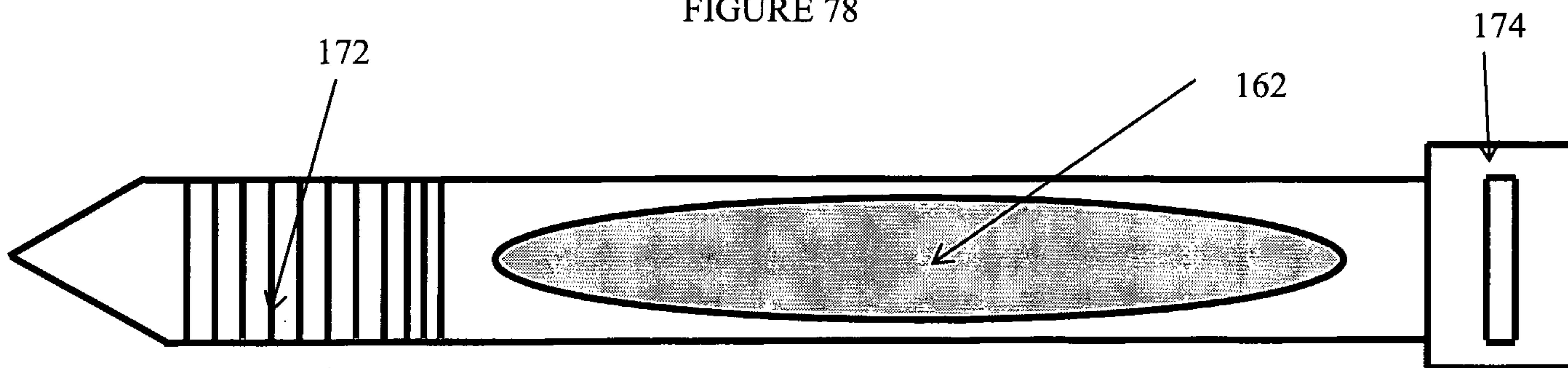

FIGURE 79

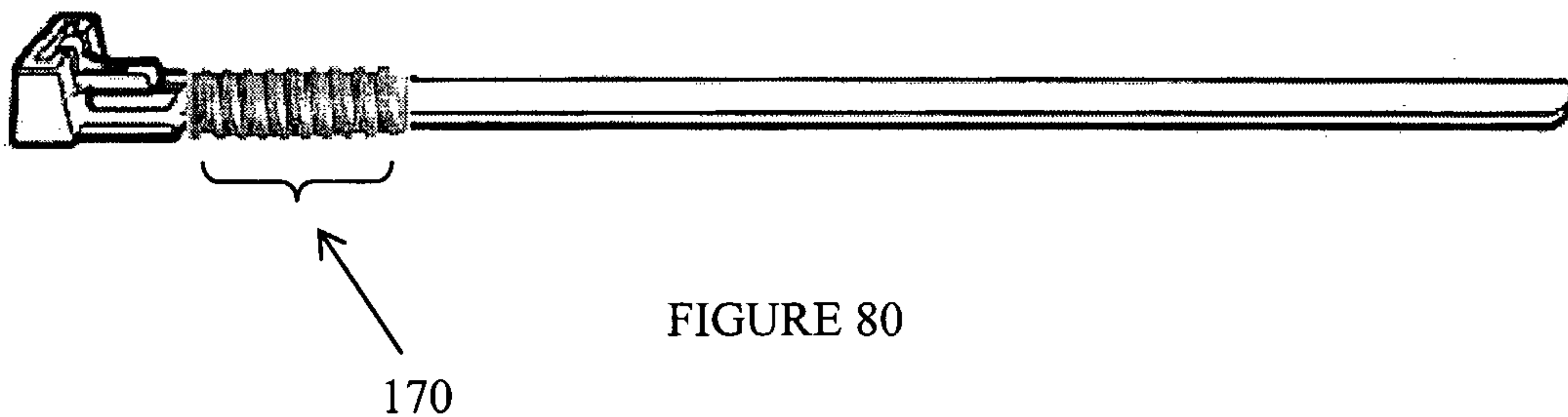

FIGURE 80

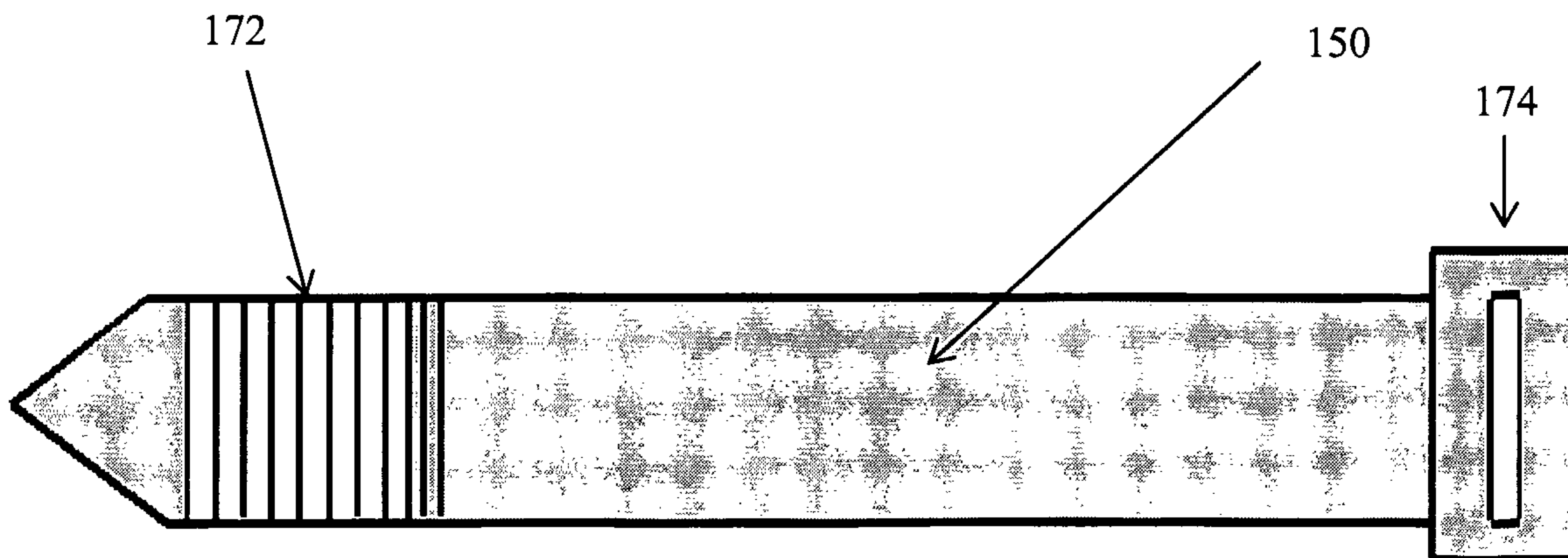
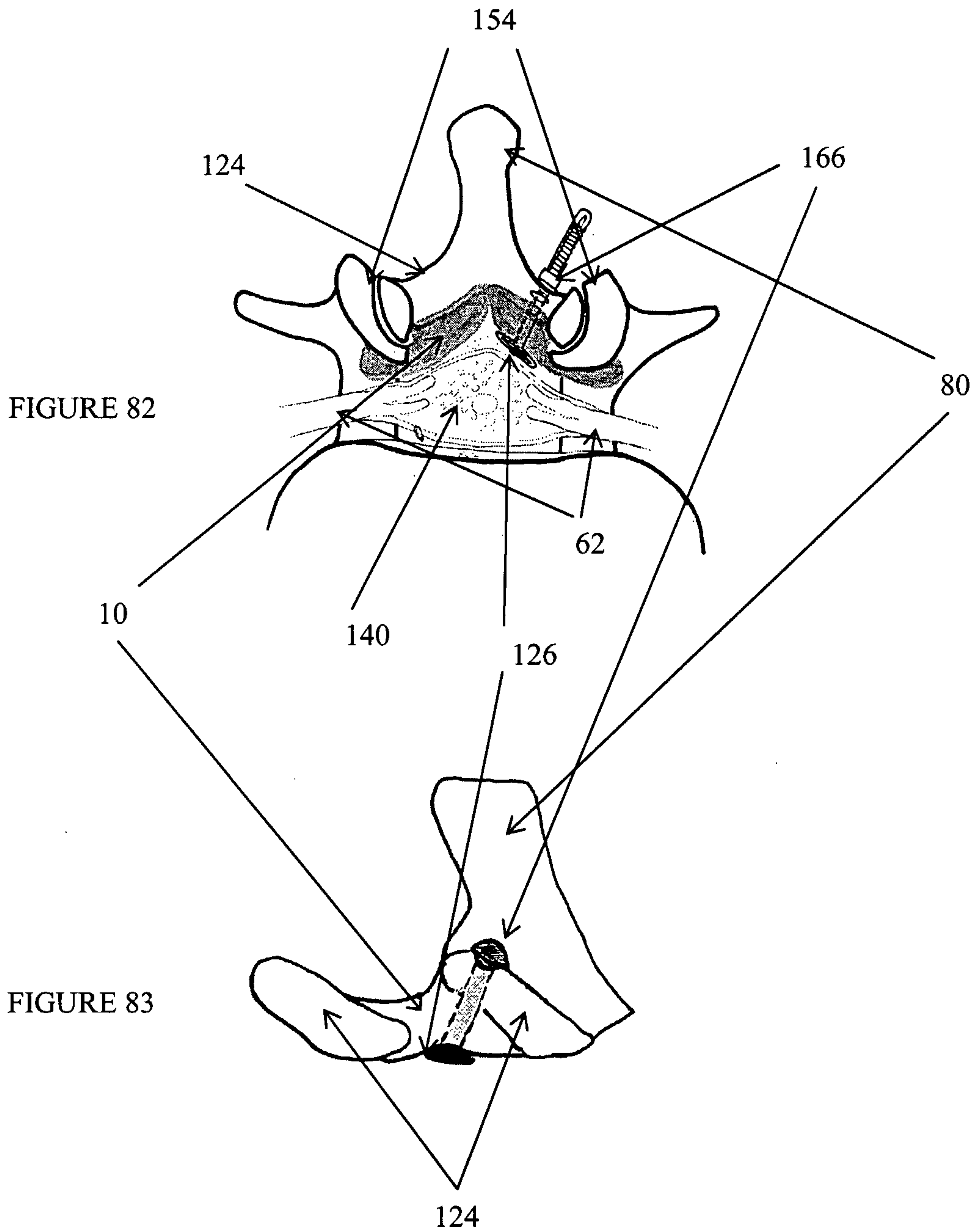

FIGURE 81





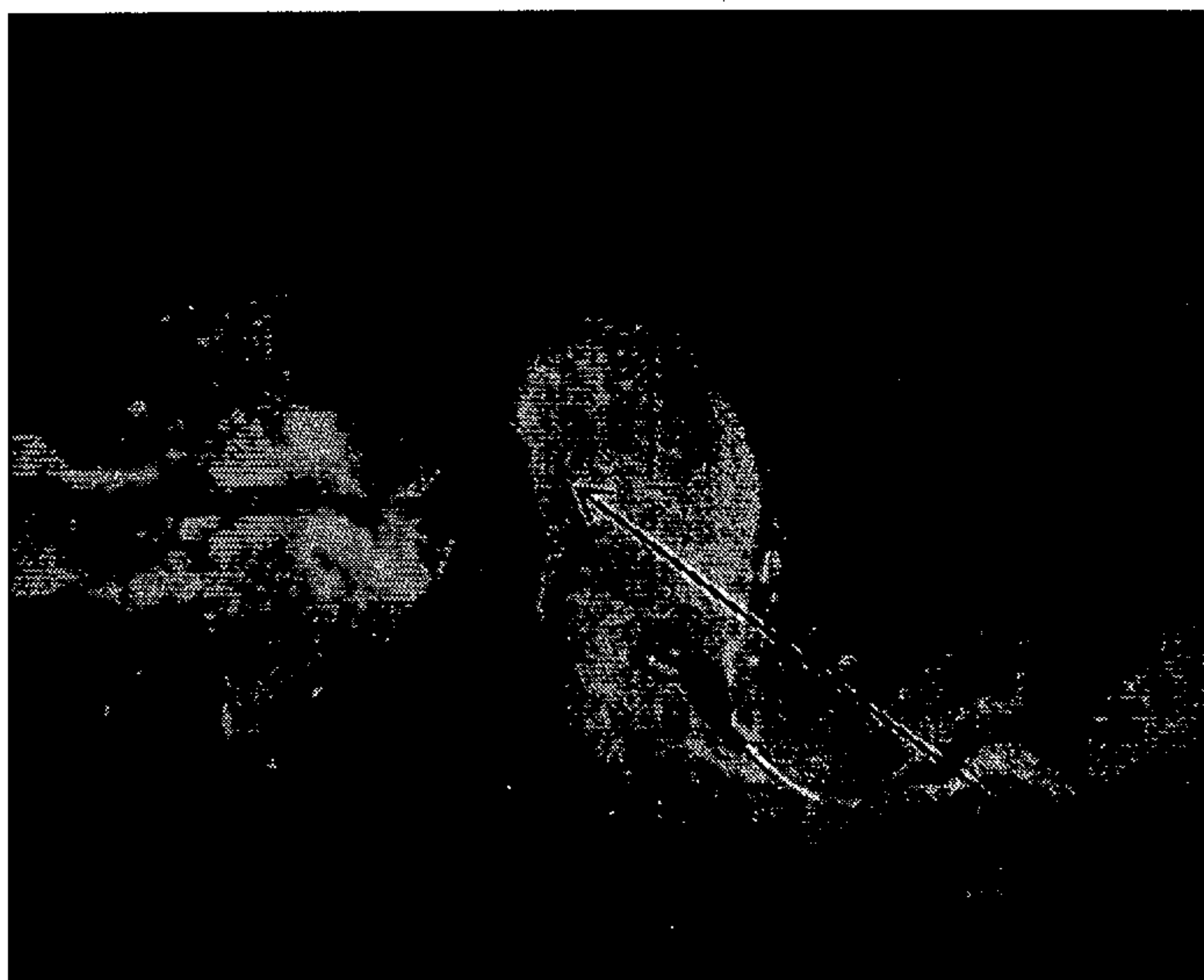
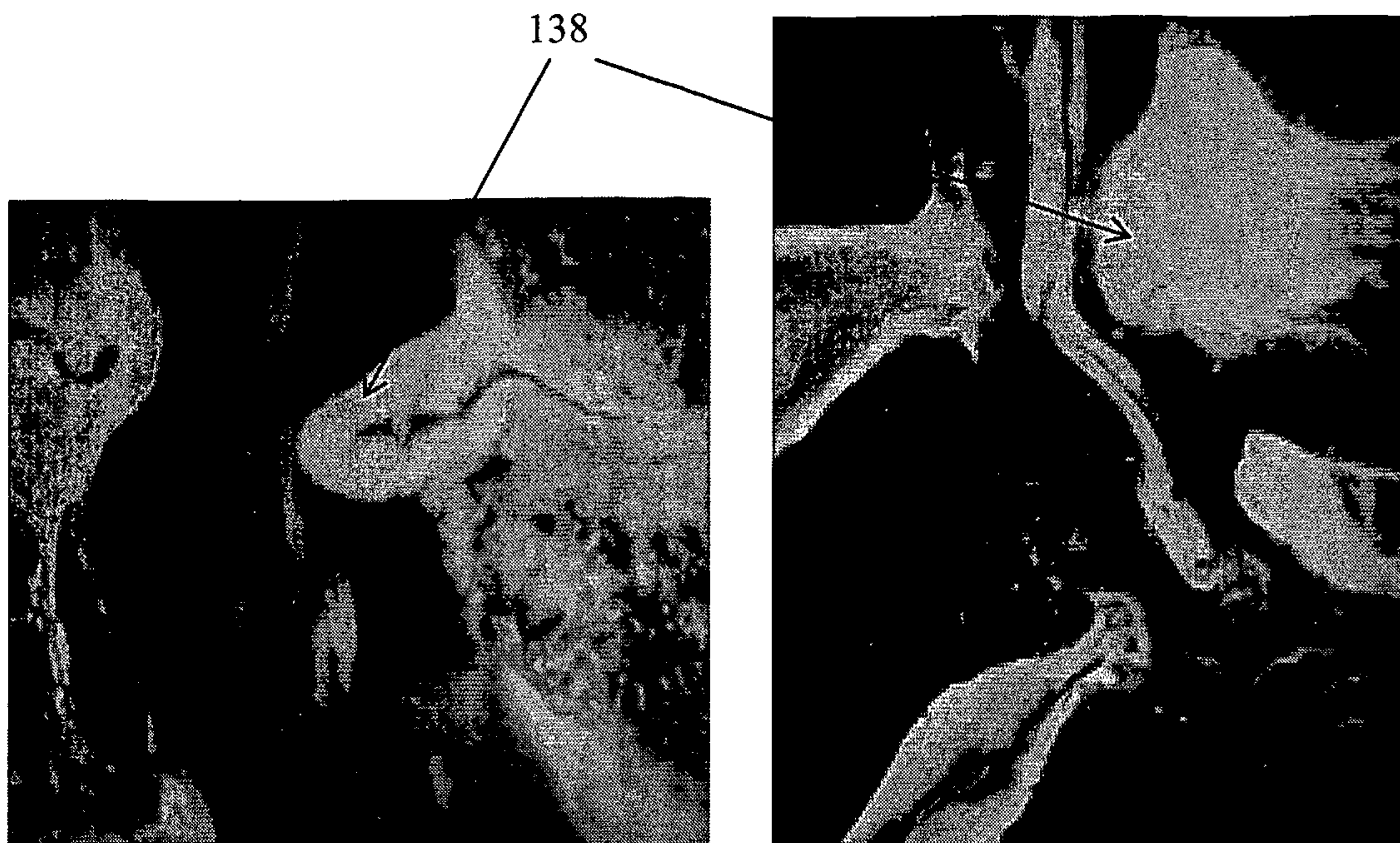

FIGURE 84 a, b, c

138

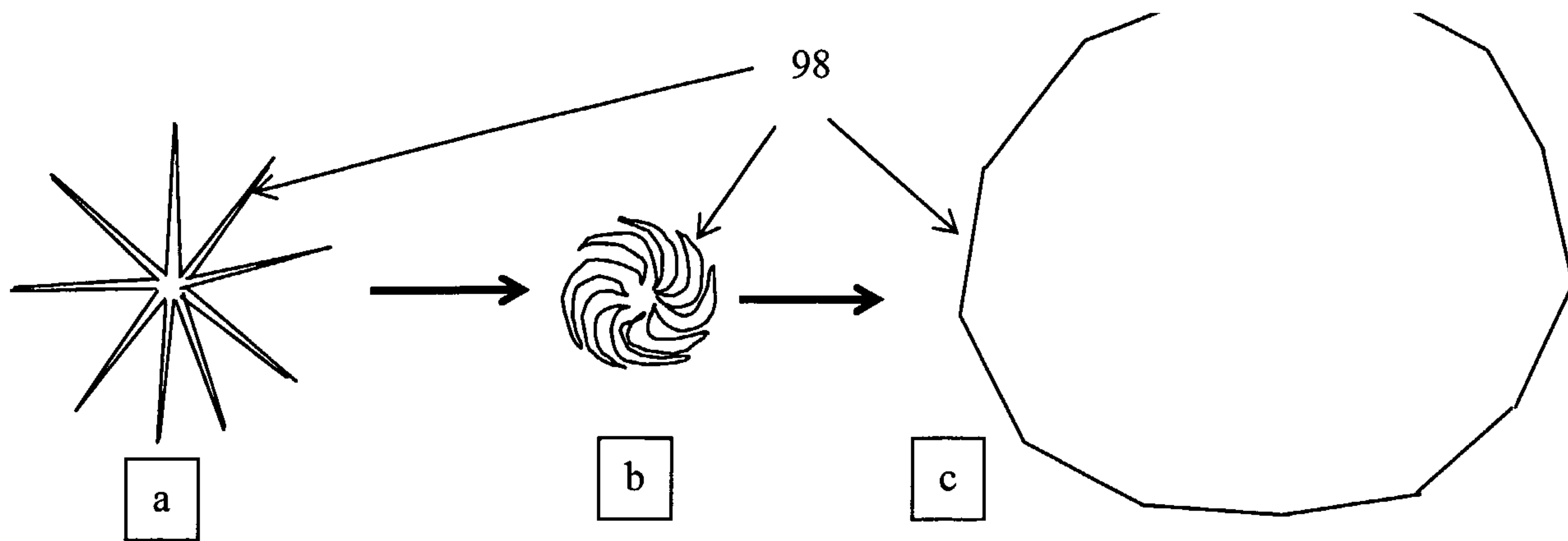

FIGURE 85 a, b, c

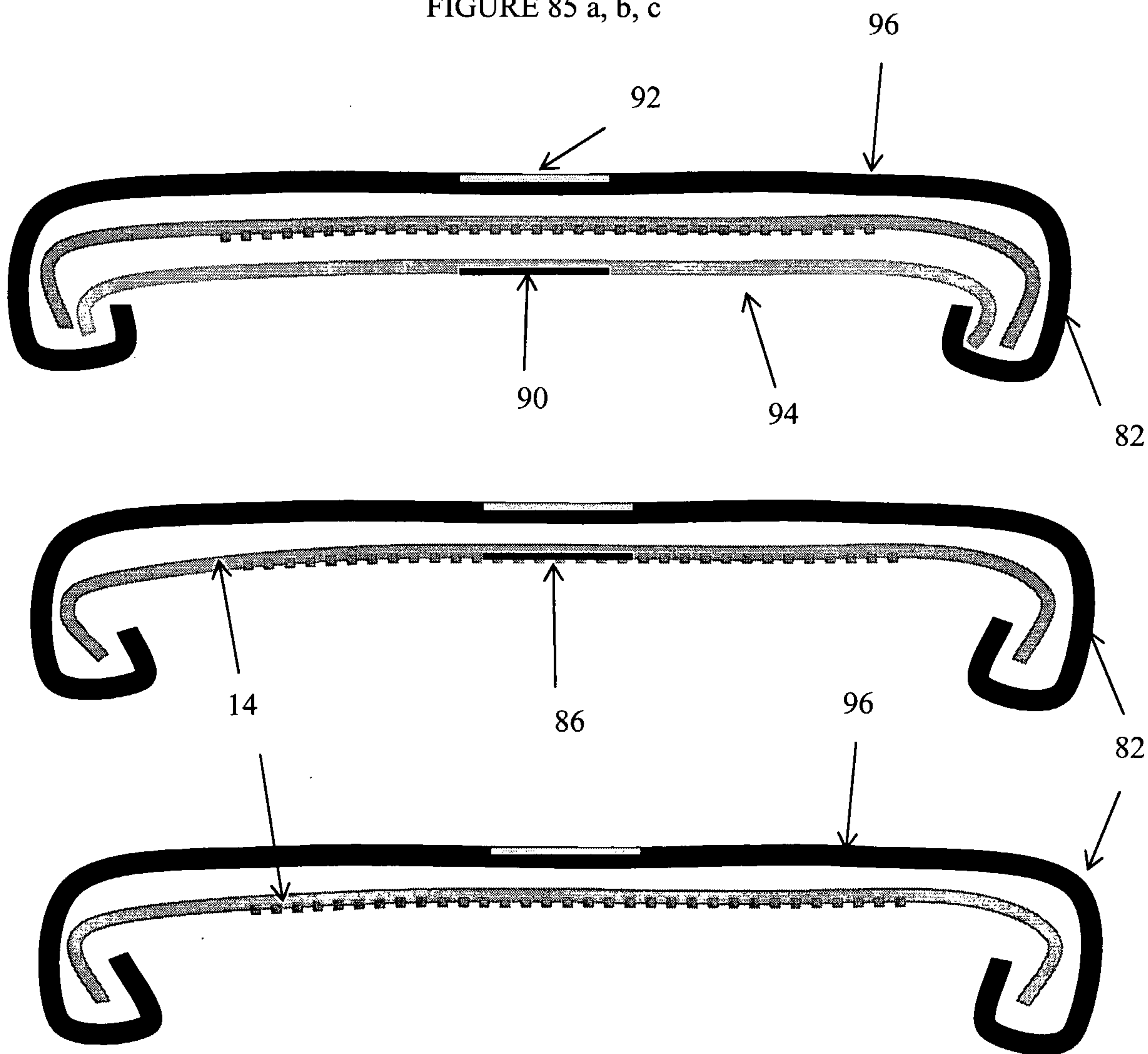

FIGURE 86 a, b, c



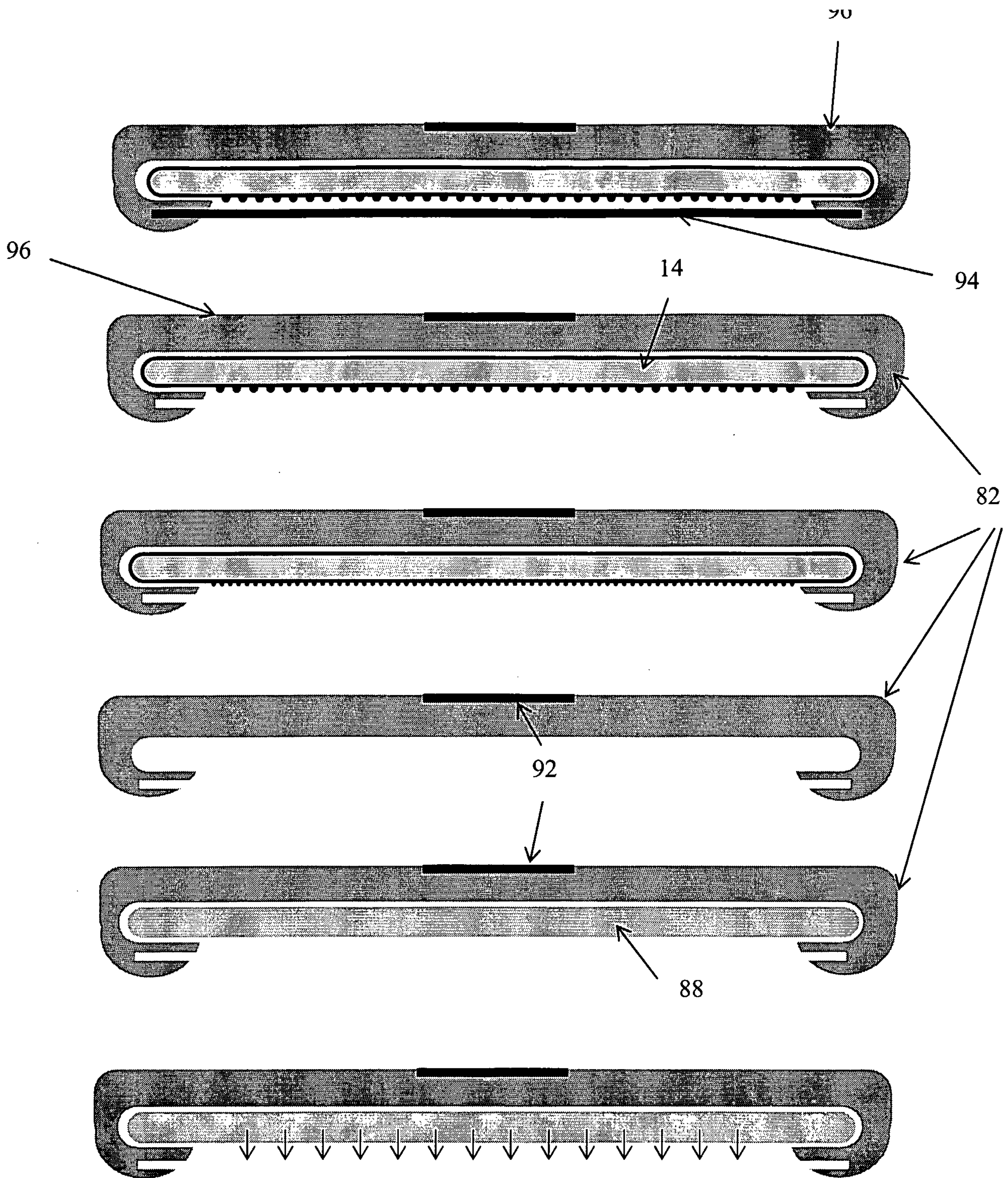

FIGURE 87 a, b, c, d, e, f

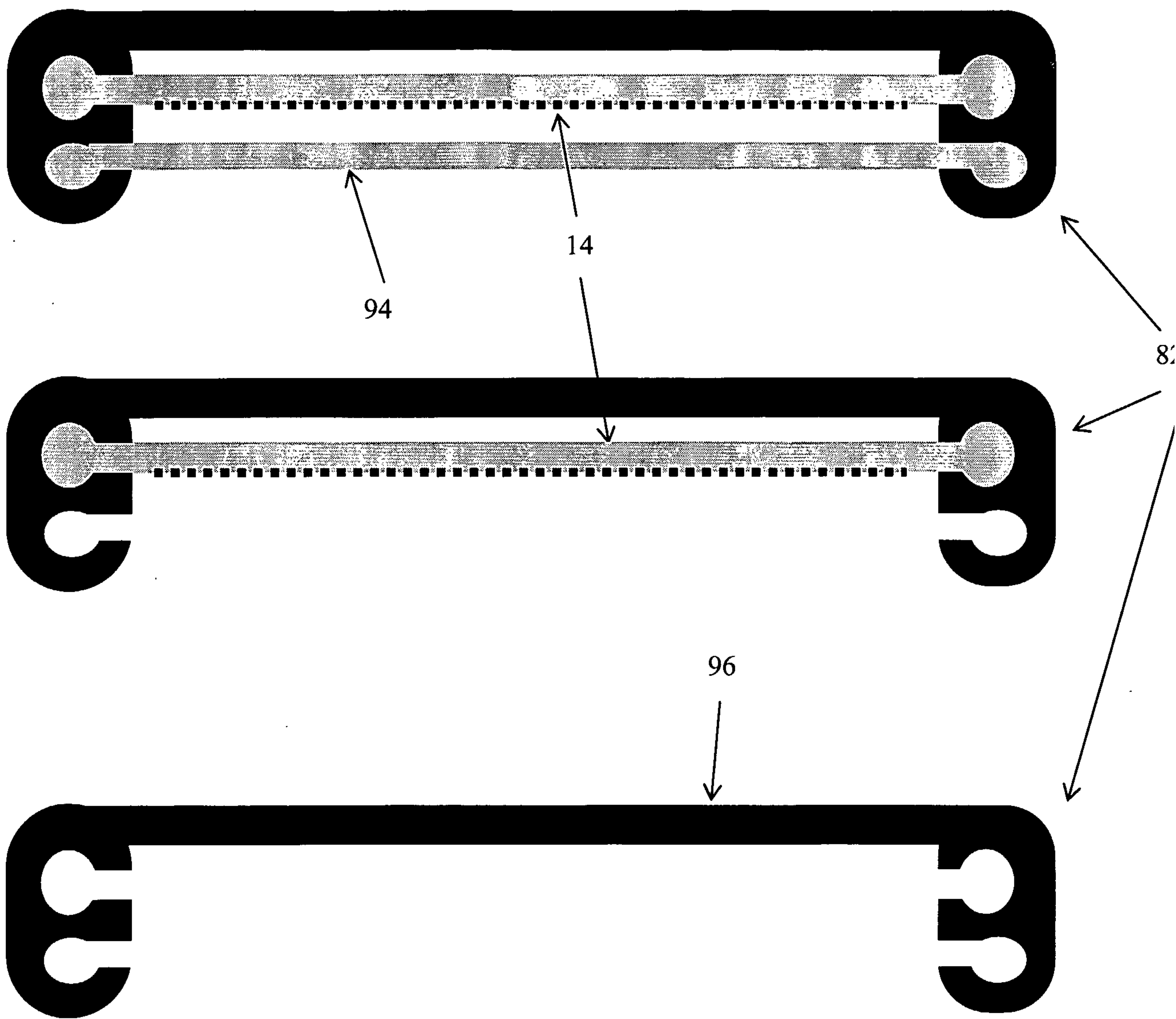

FIGURE 88 a, b, c



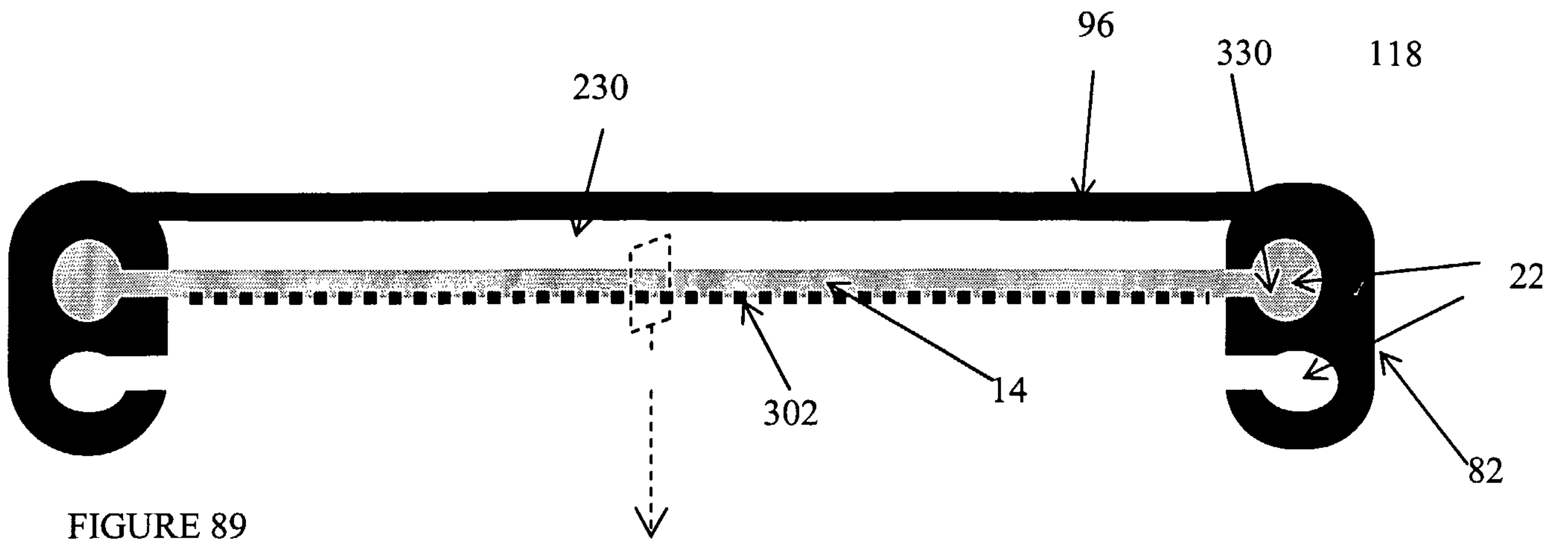

FIGURE 89

Rotated saggital section view of above x-section

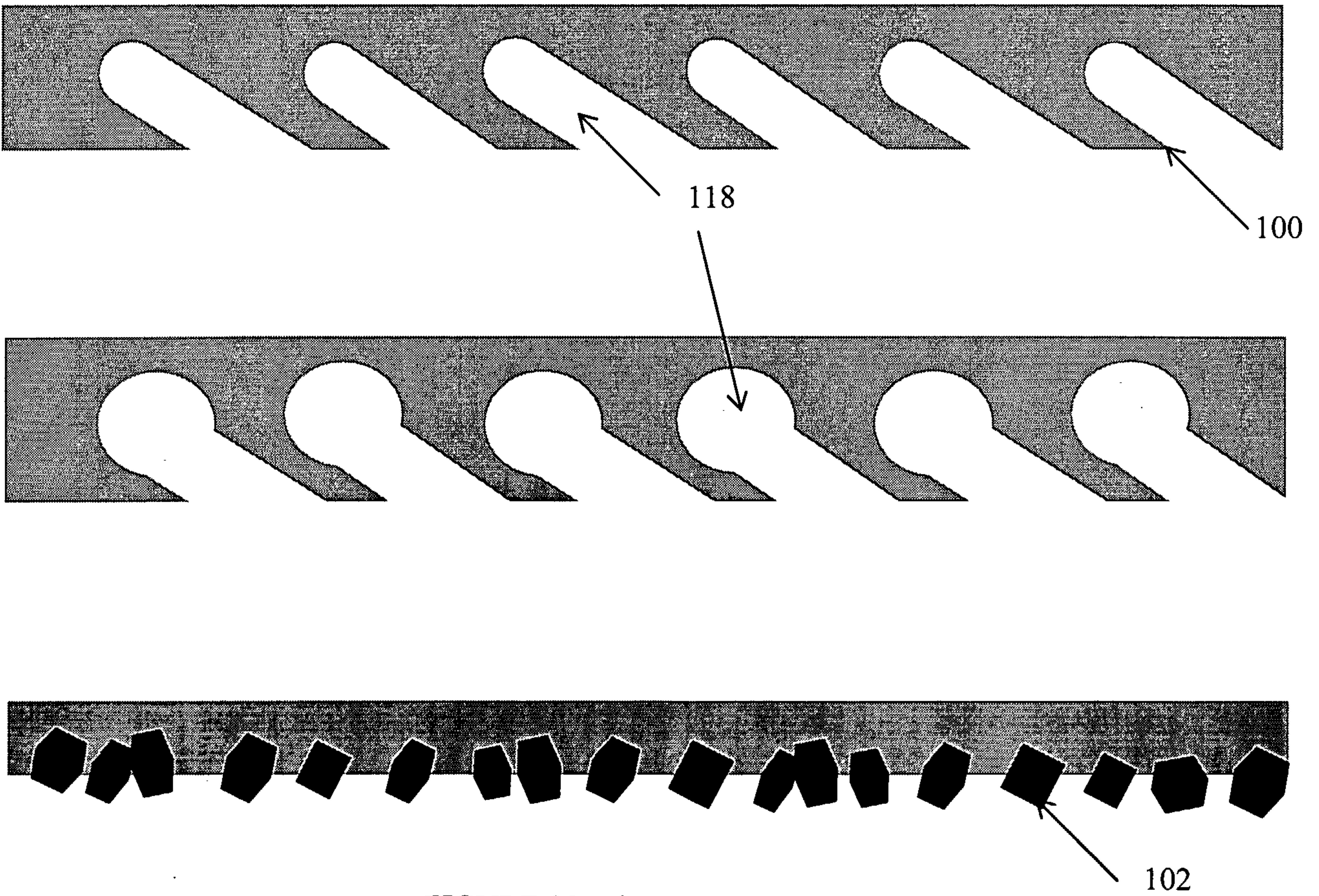

FIGURE 90 a, b, c



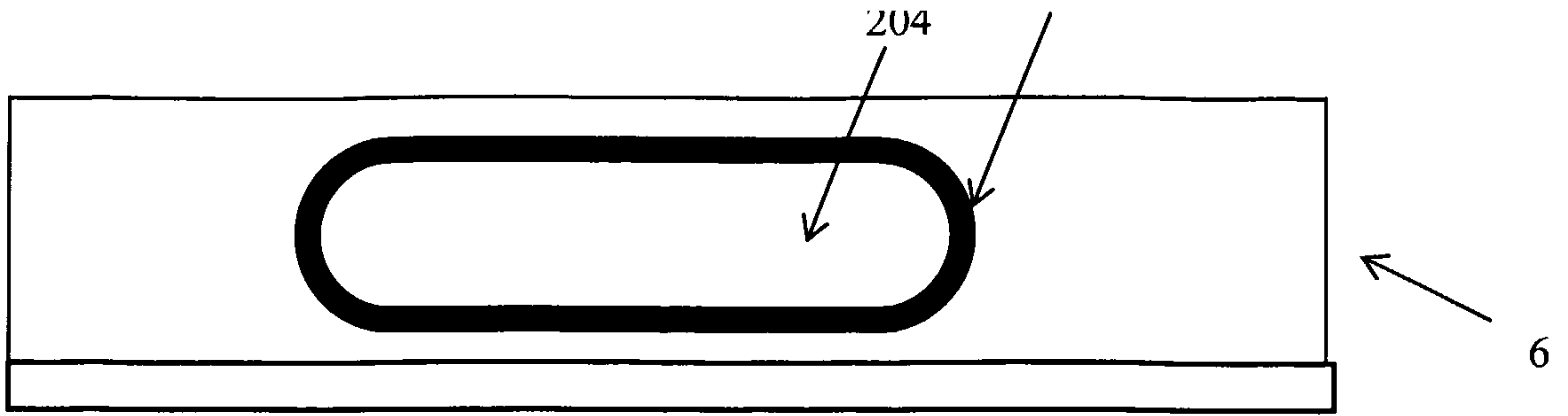

Figure 91A

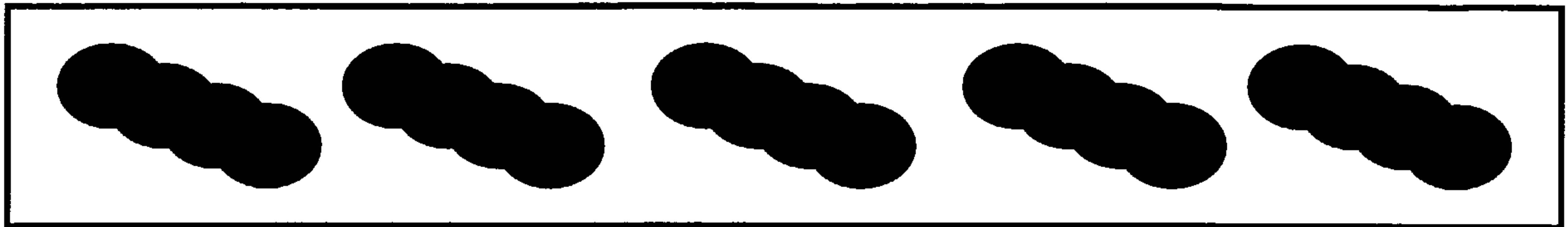

Figure 91B

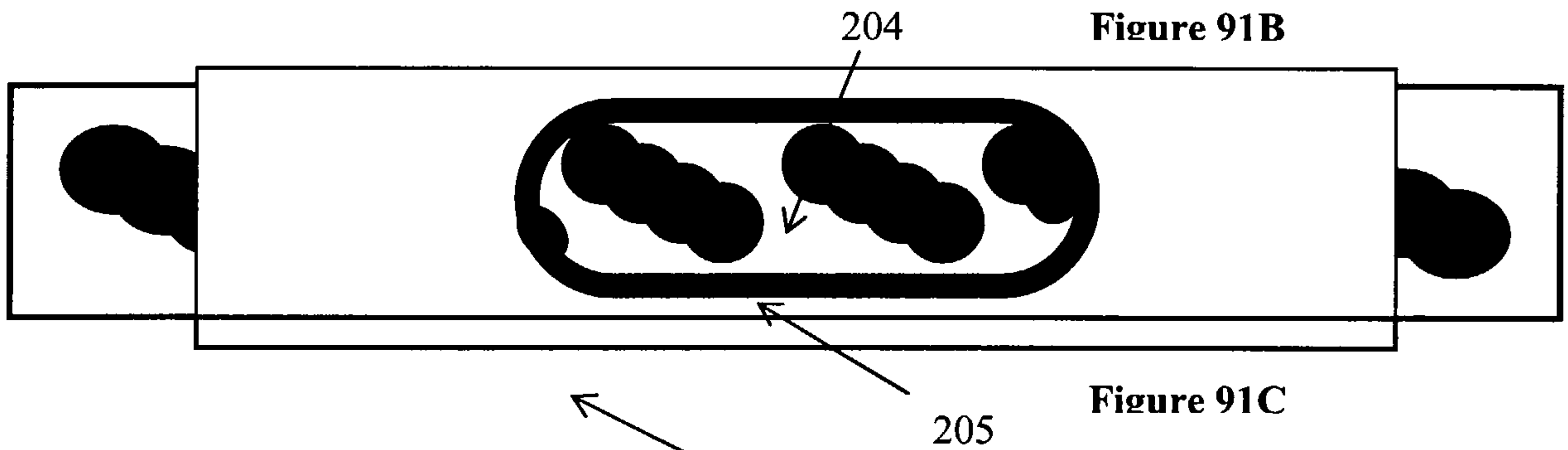

Figure 91C

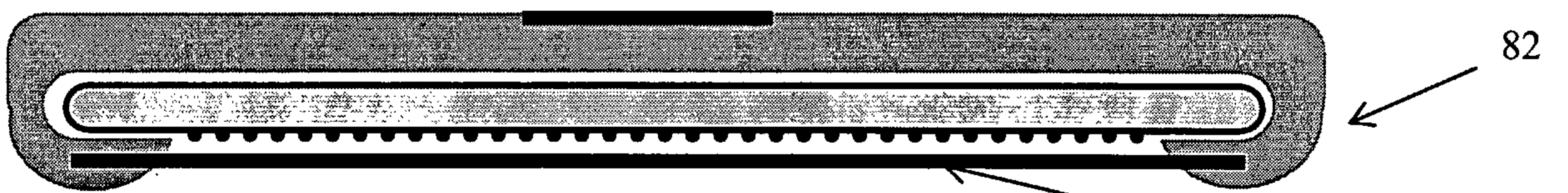

Figure 91D

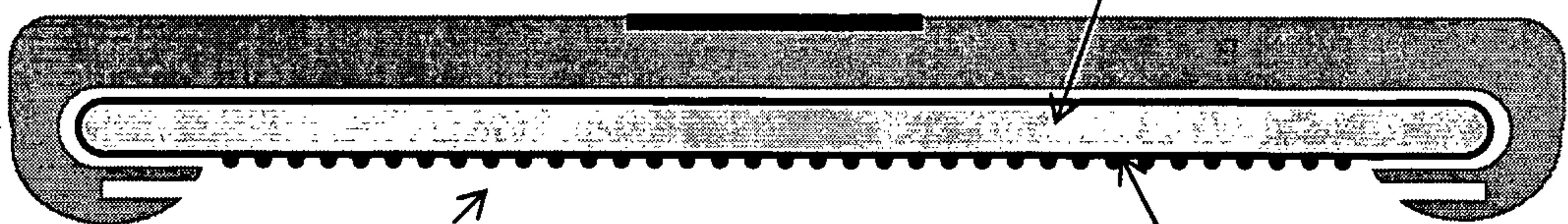
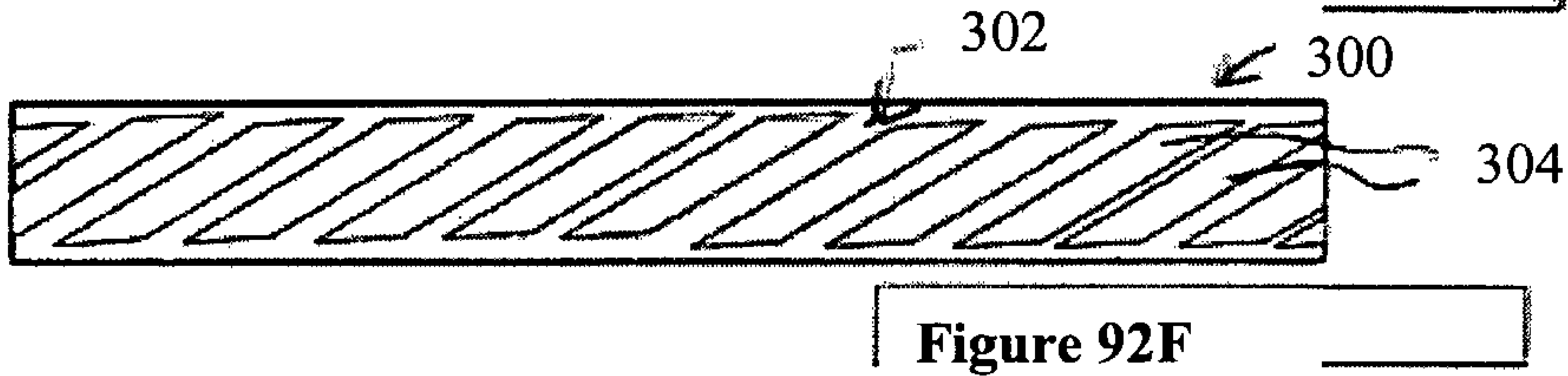
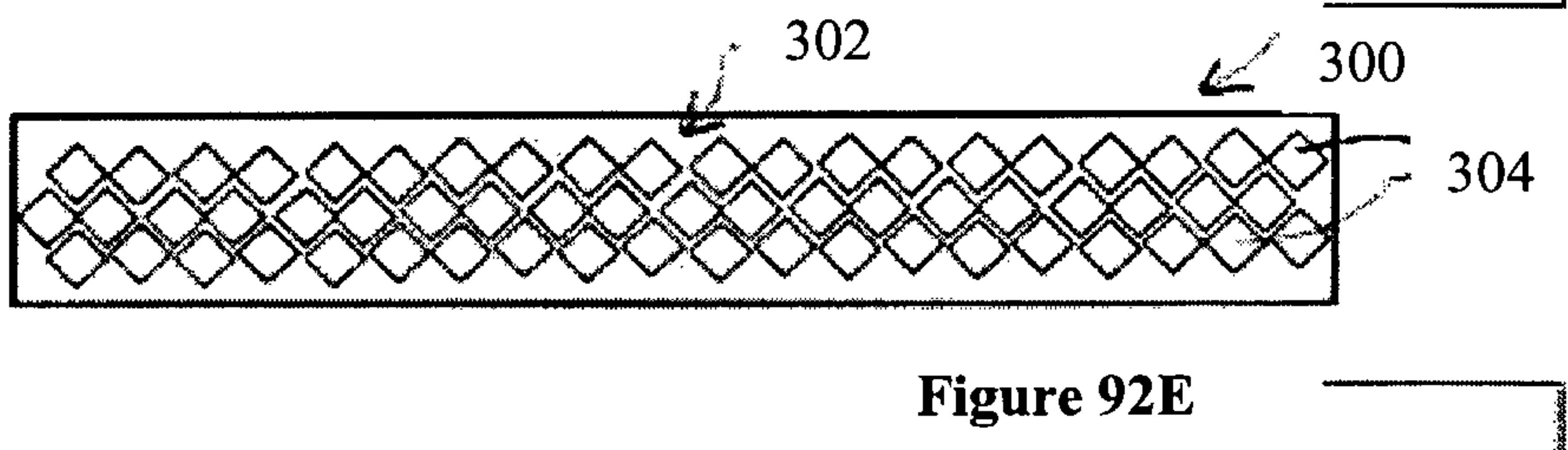
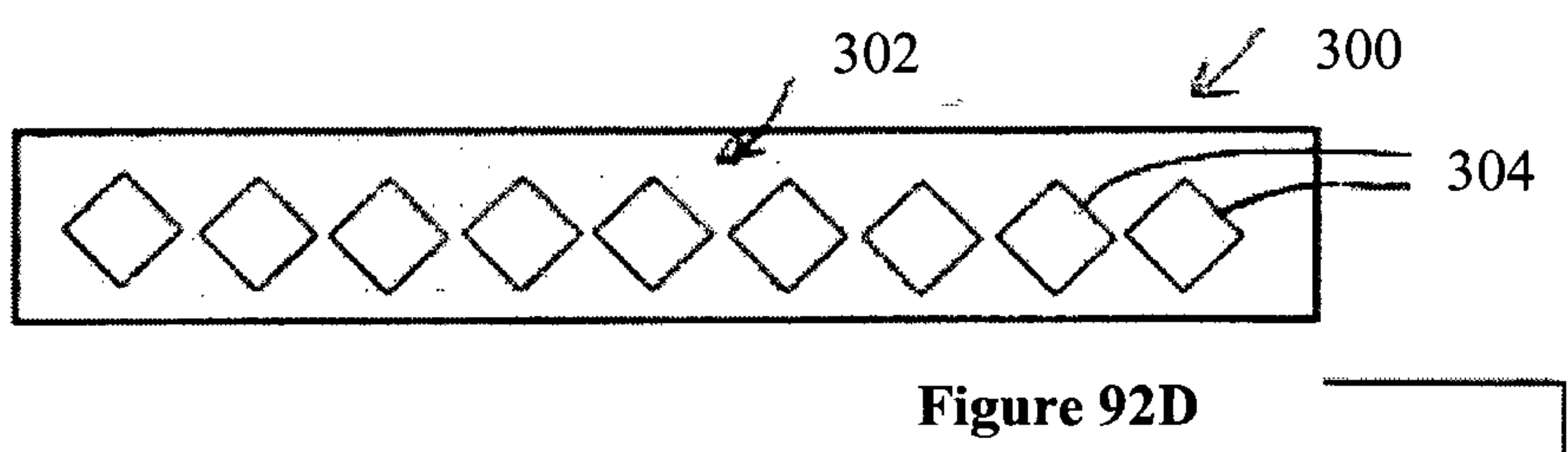
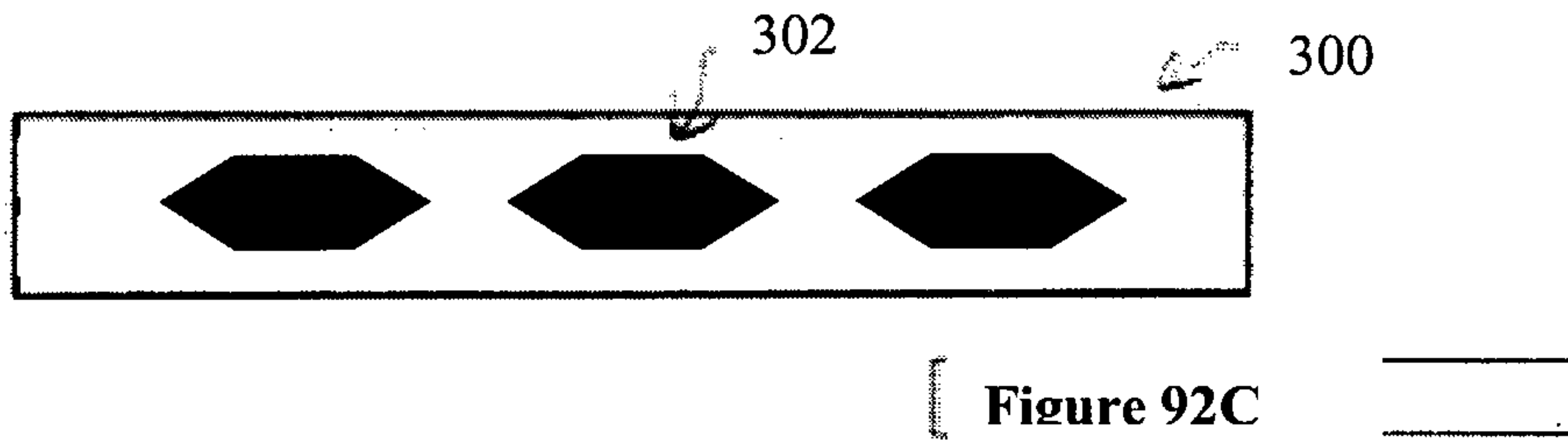
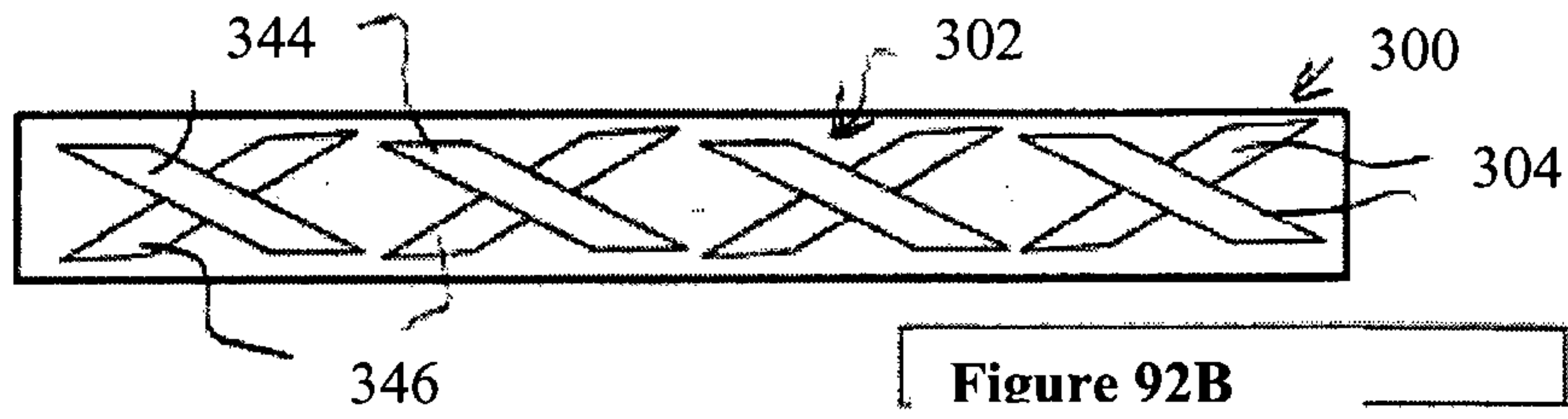
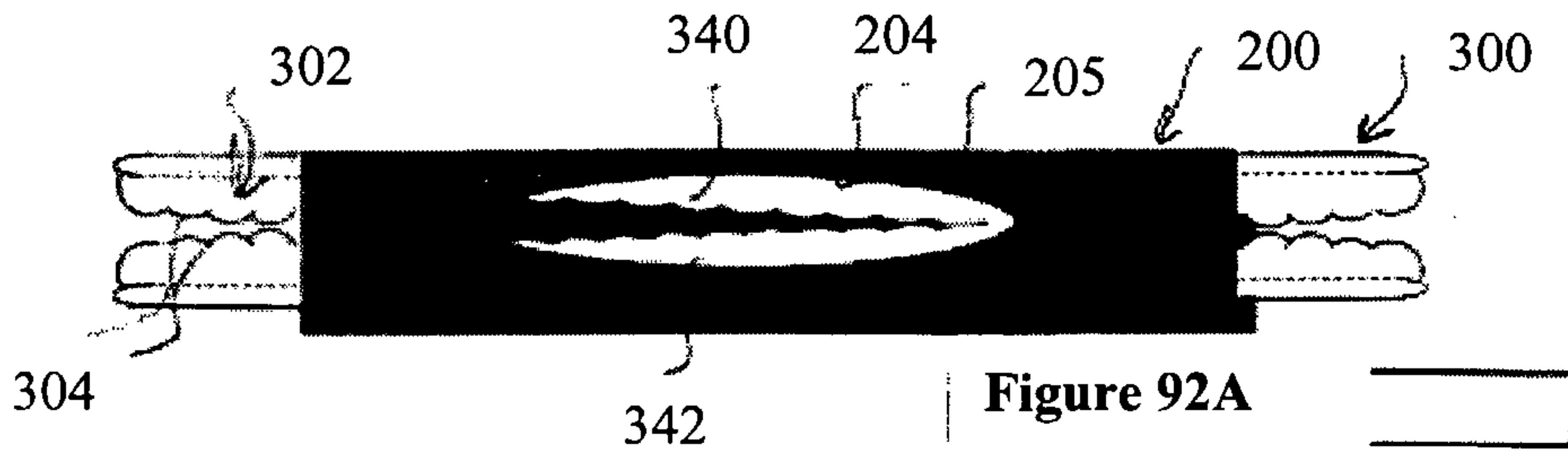

Figure 91E







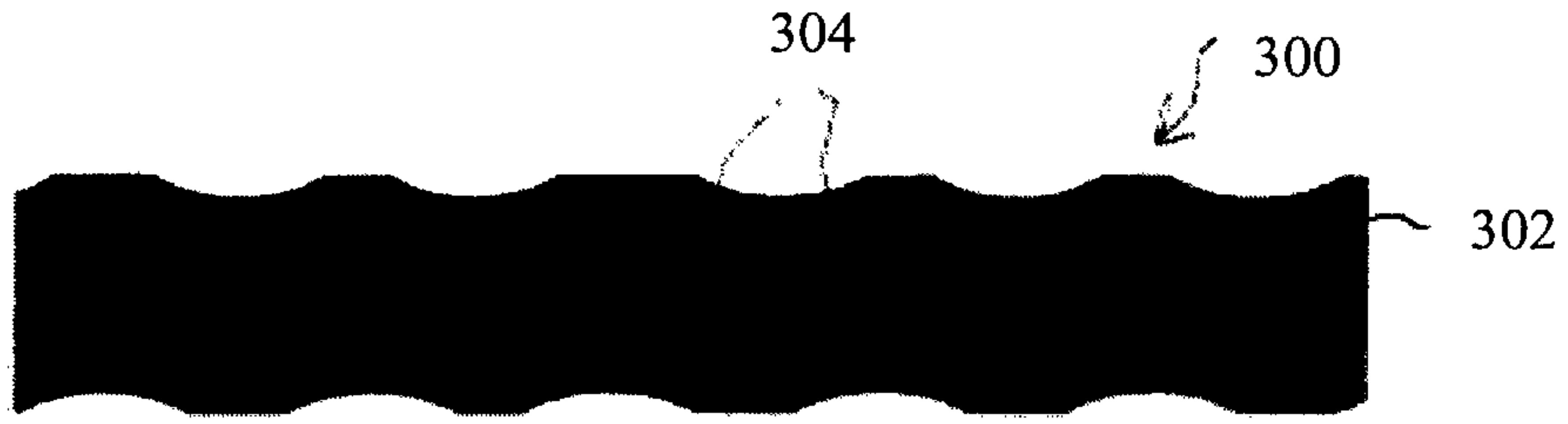

Figure 92G



Figure 92H

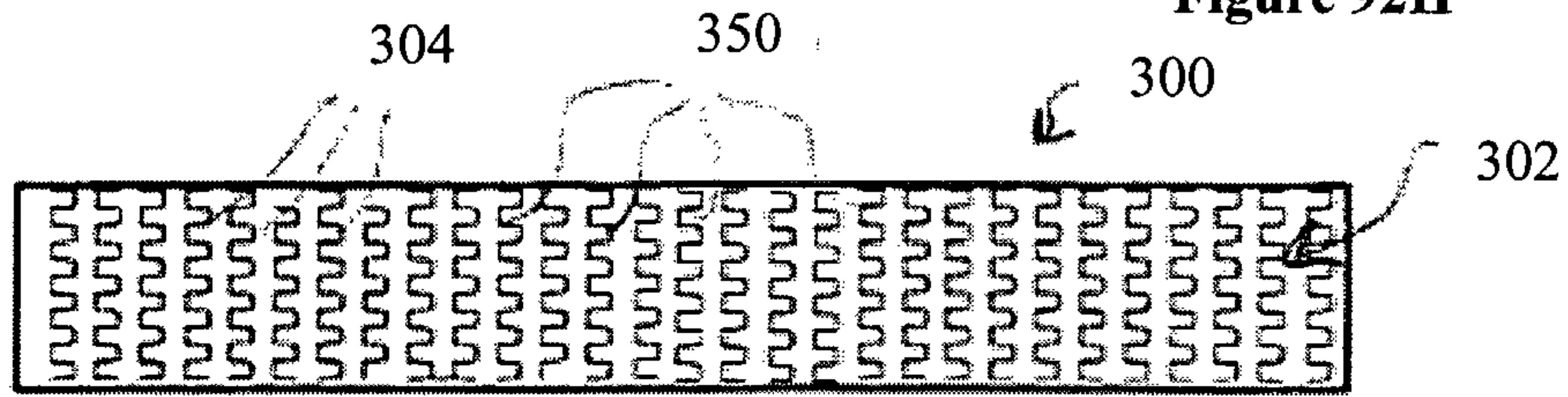

Figure 93A

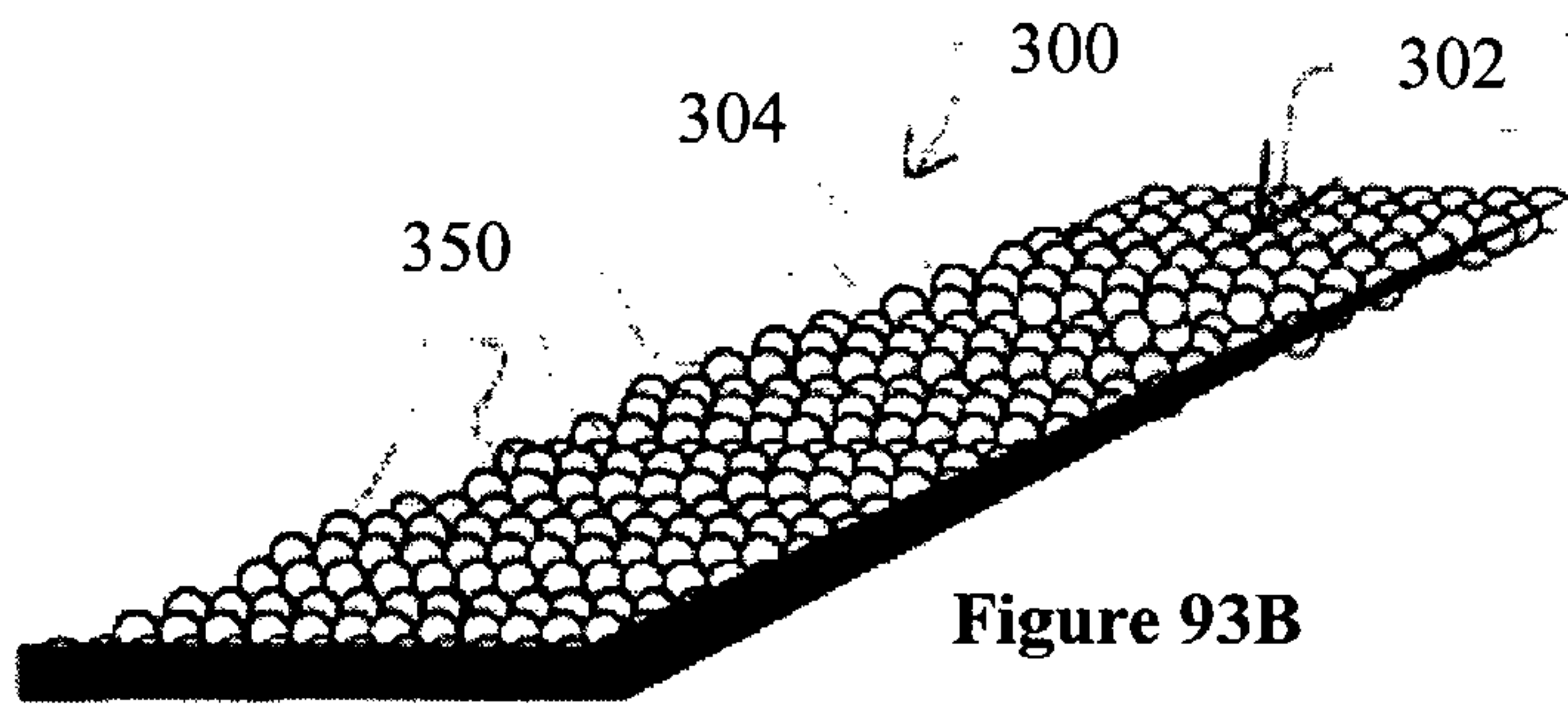

Figure 93B

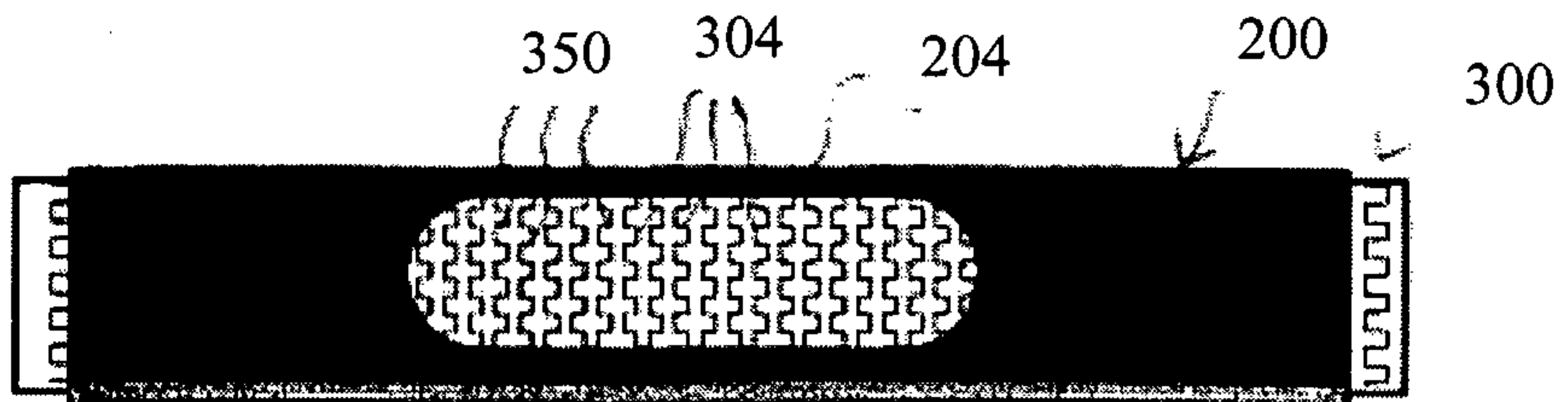

Figure 93C



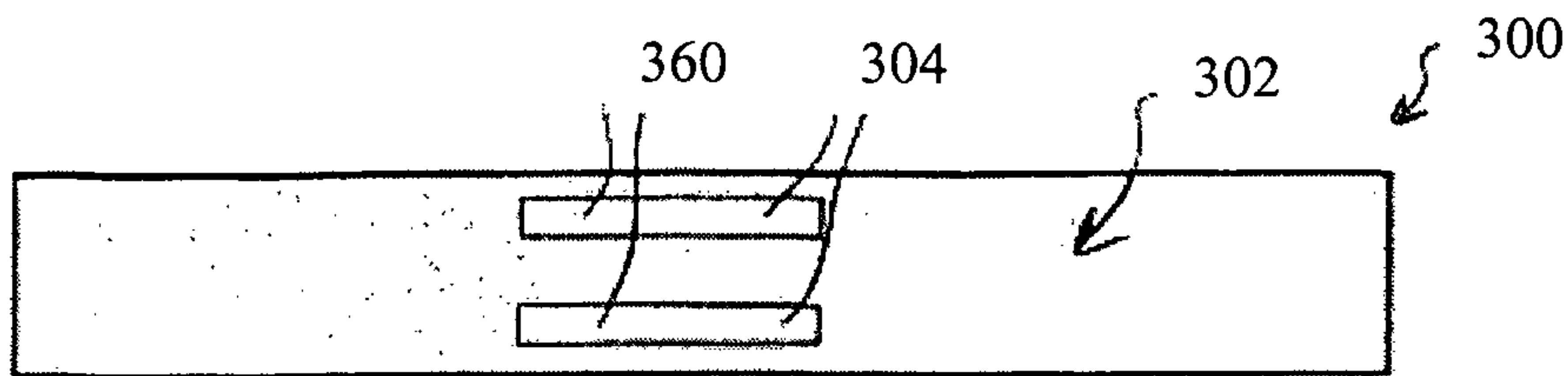

Figure 94

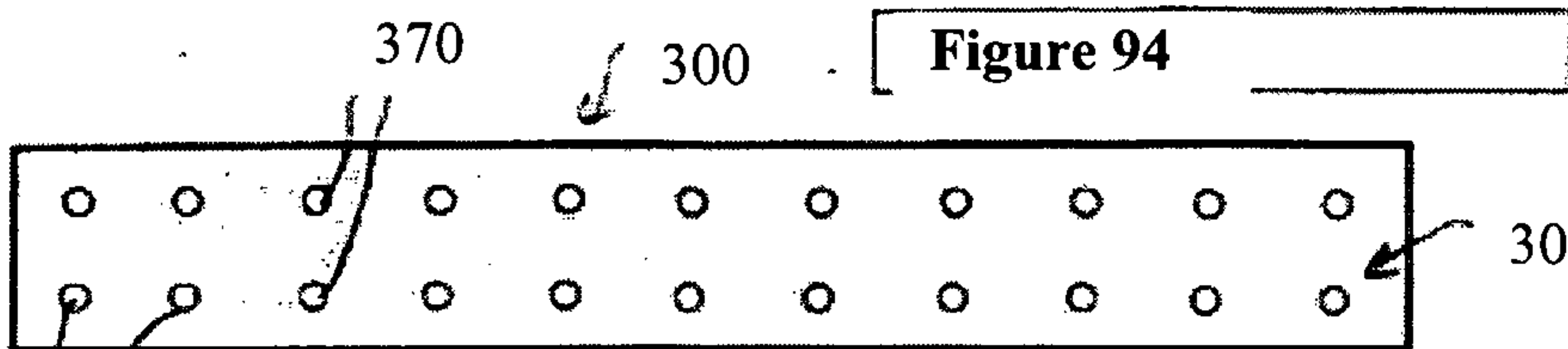

Figure 95

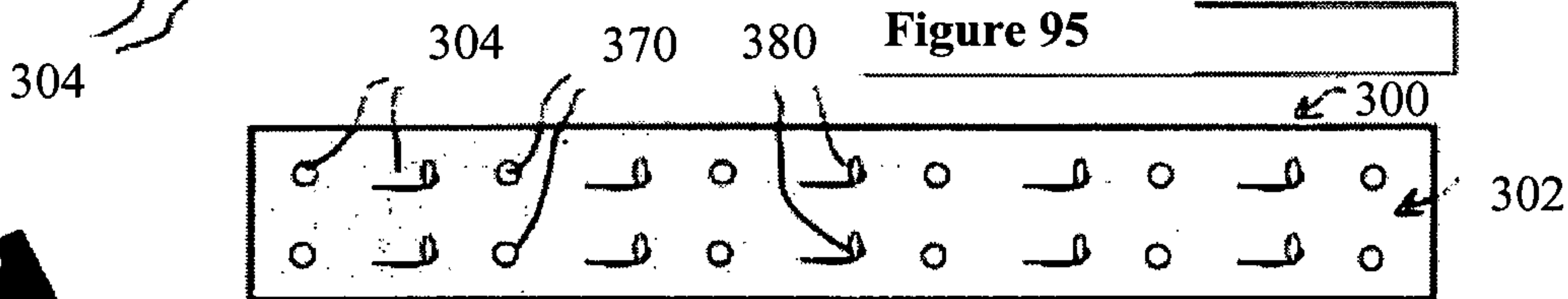

Figure 96

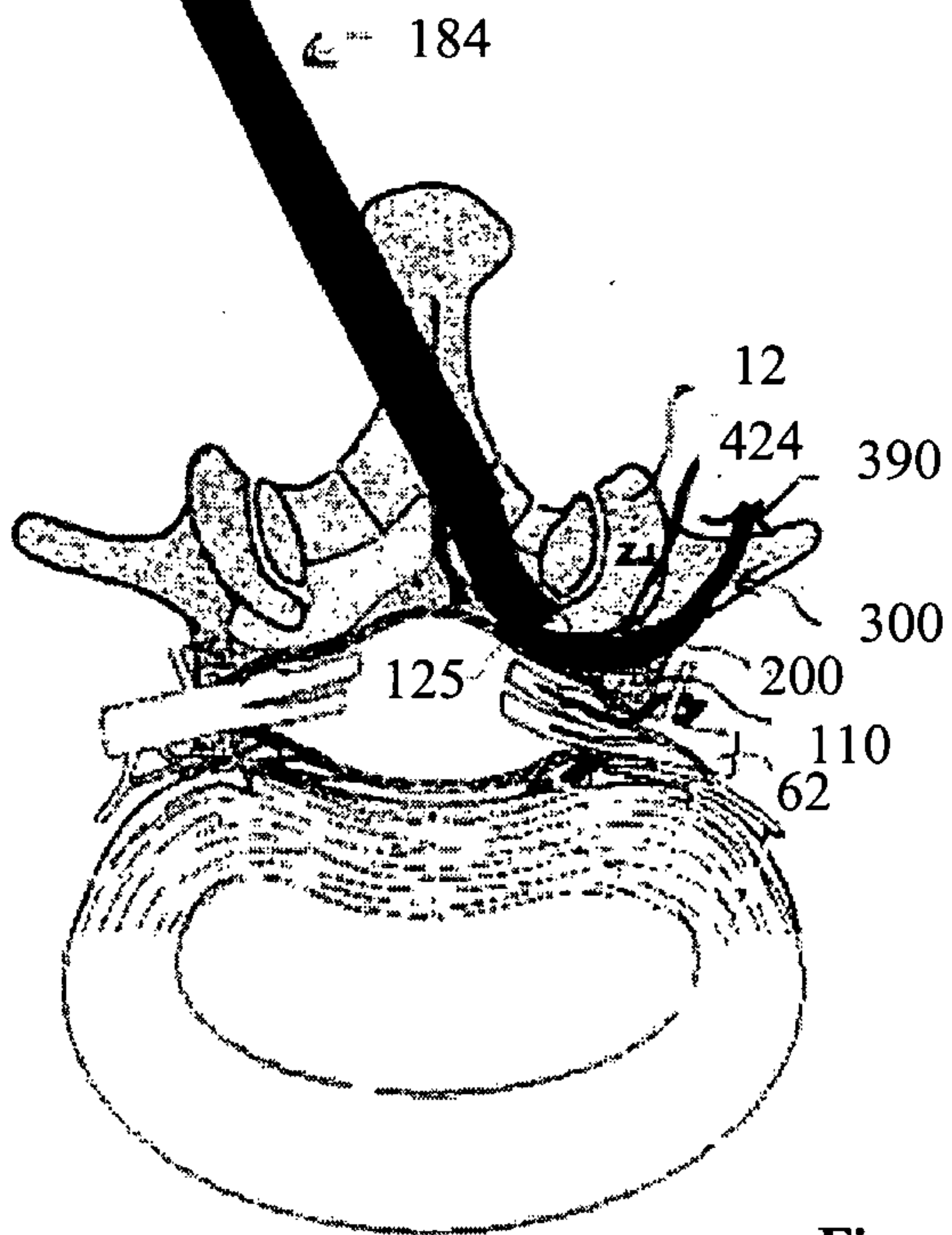

Figure 97

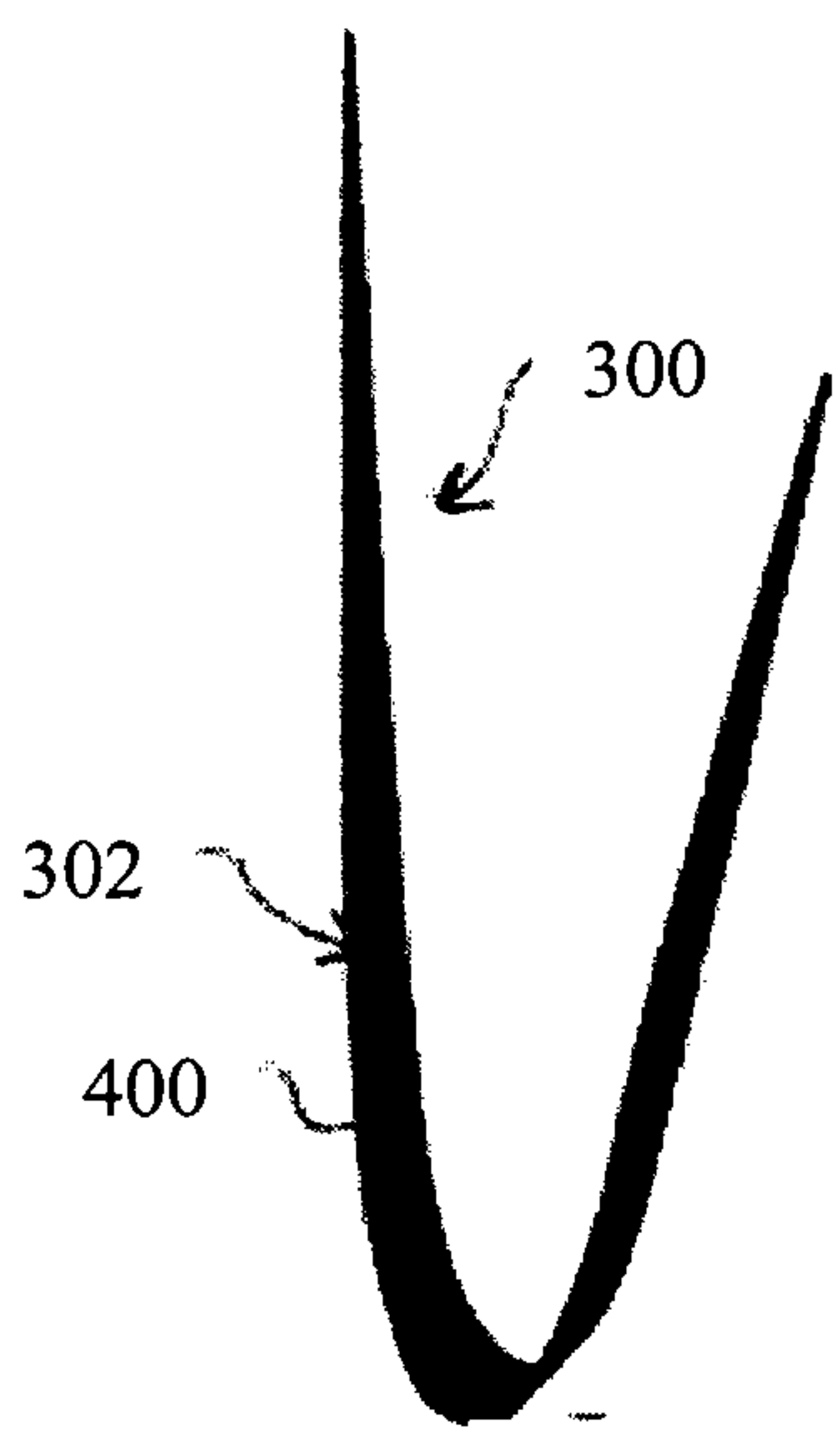

Figure 98A

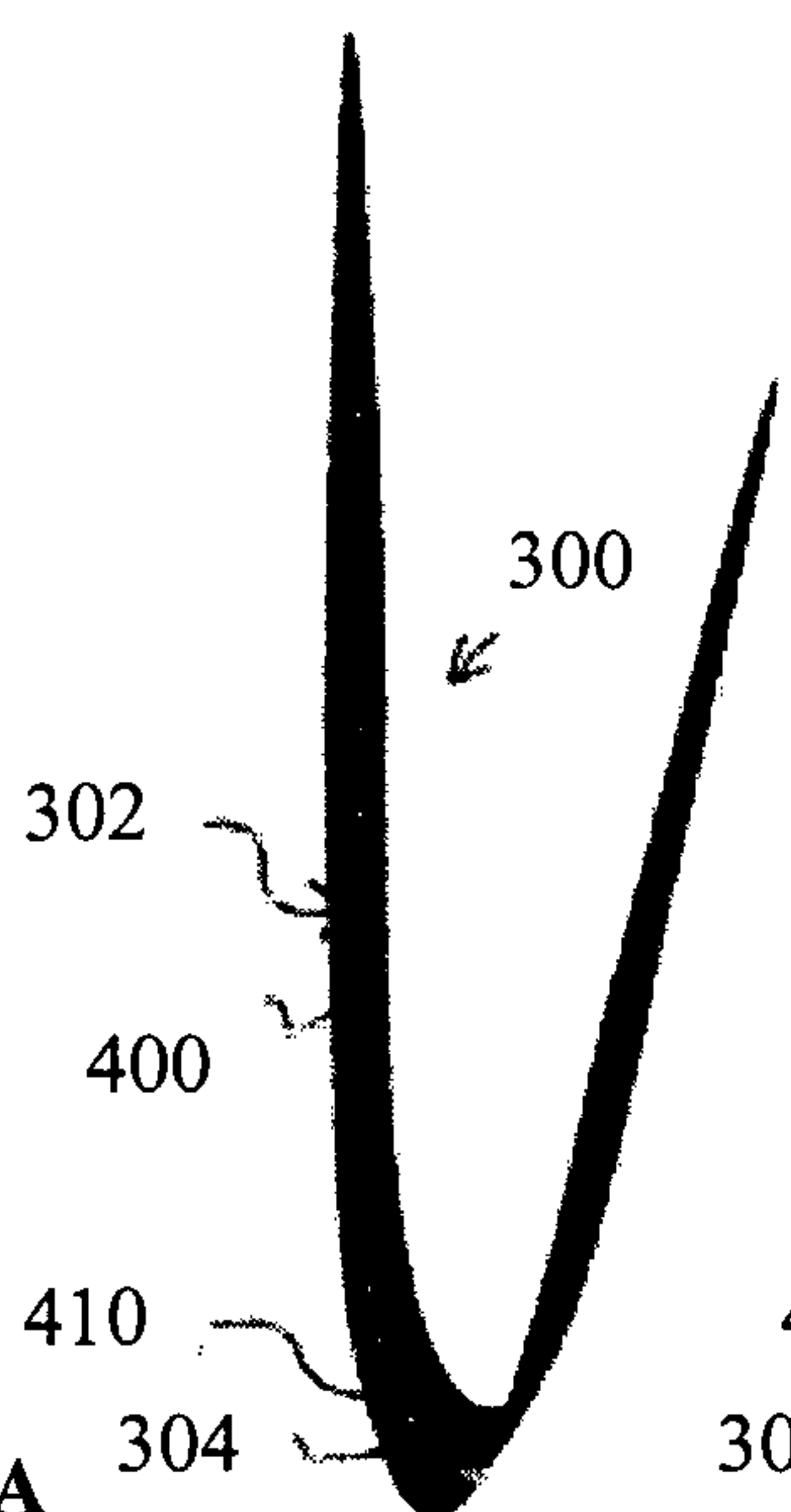

Figure 98B

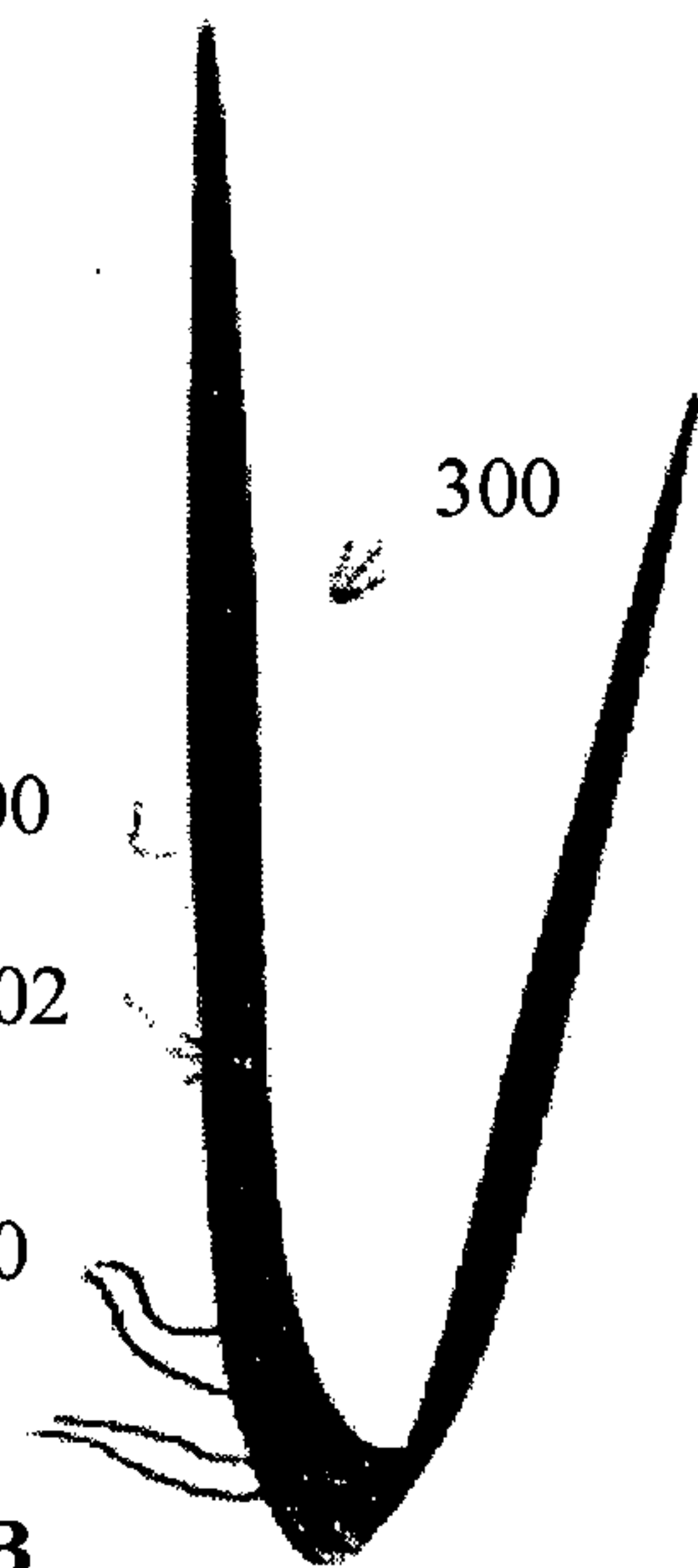

Figure 98C

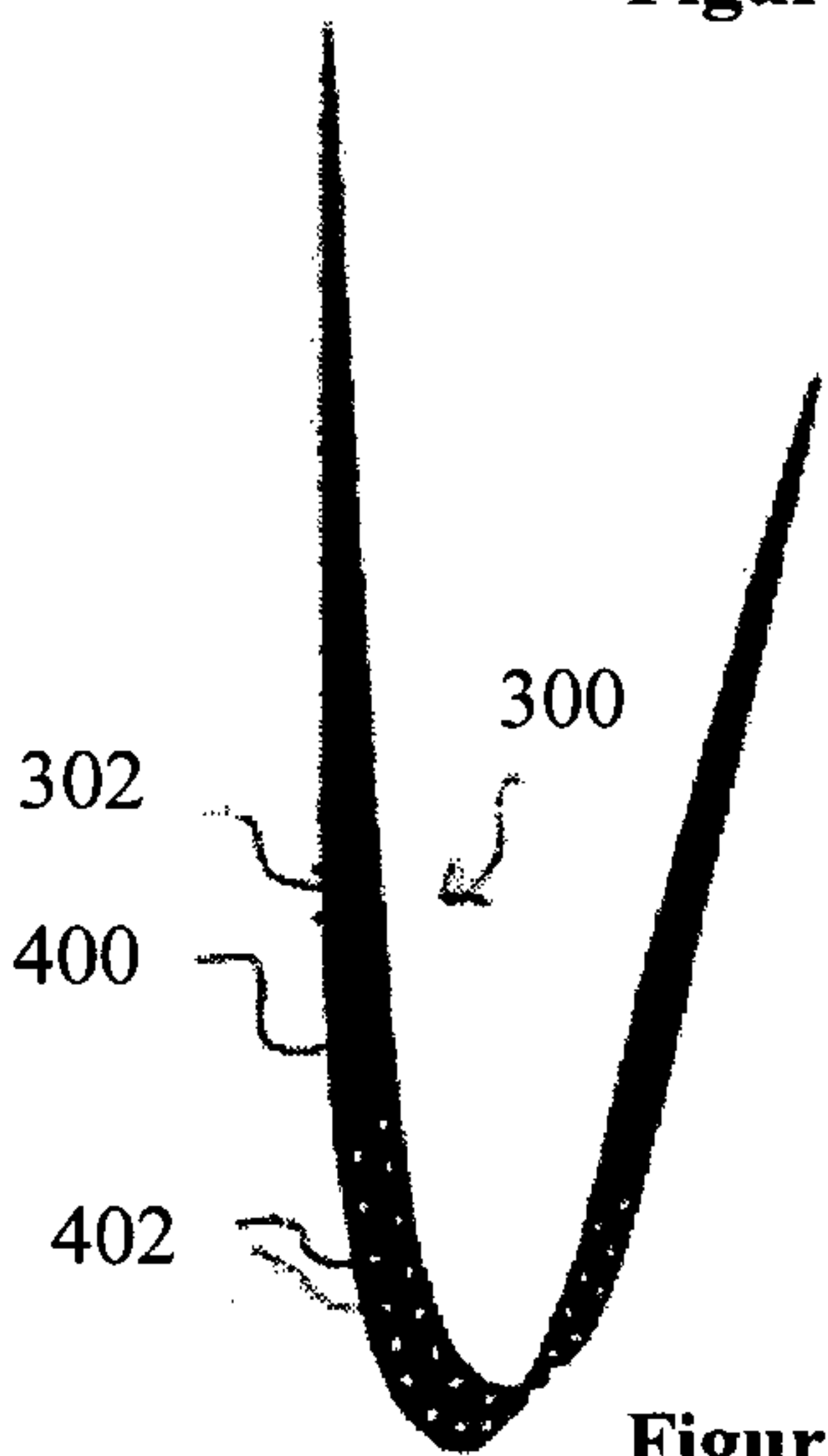

Figure 99A

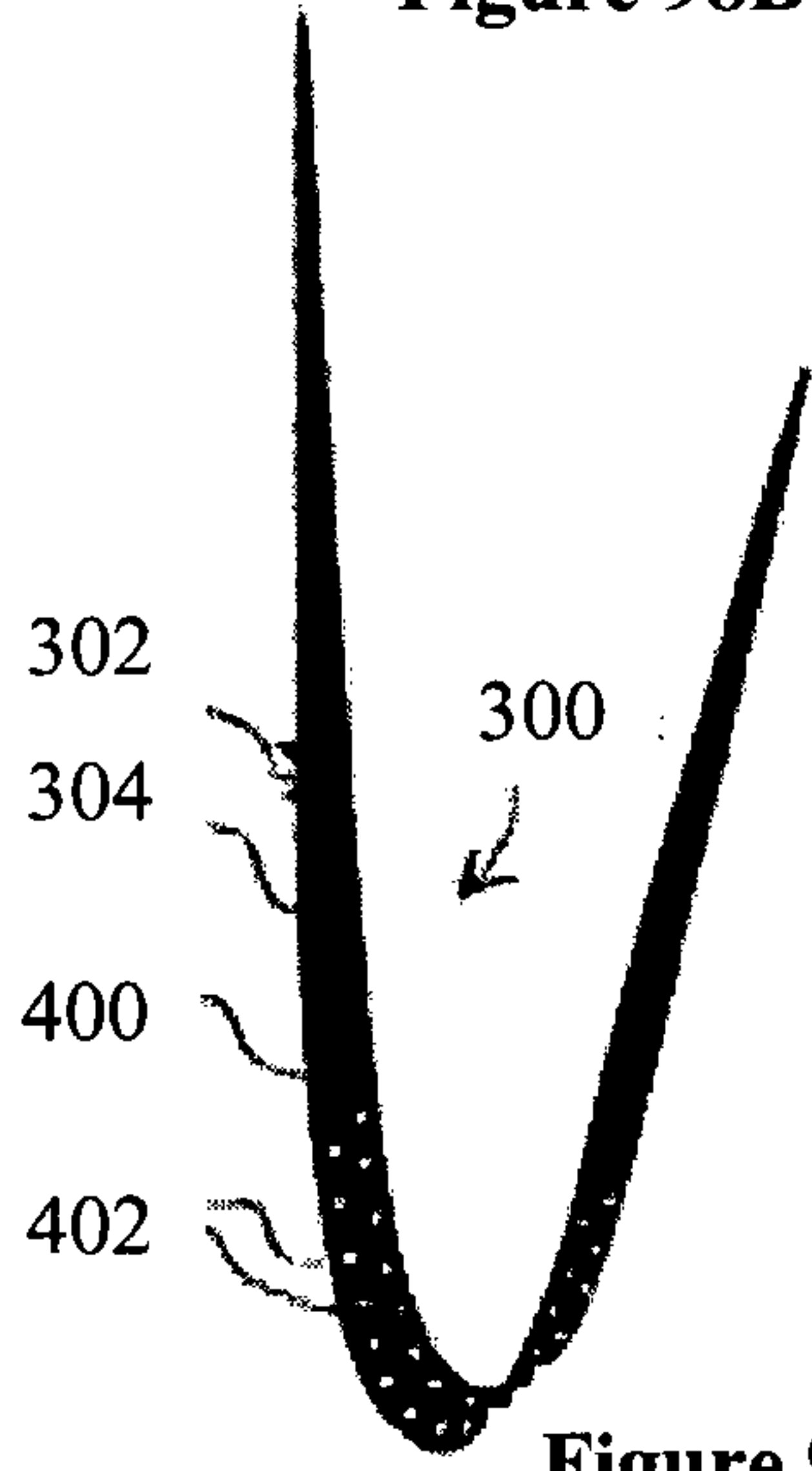
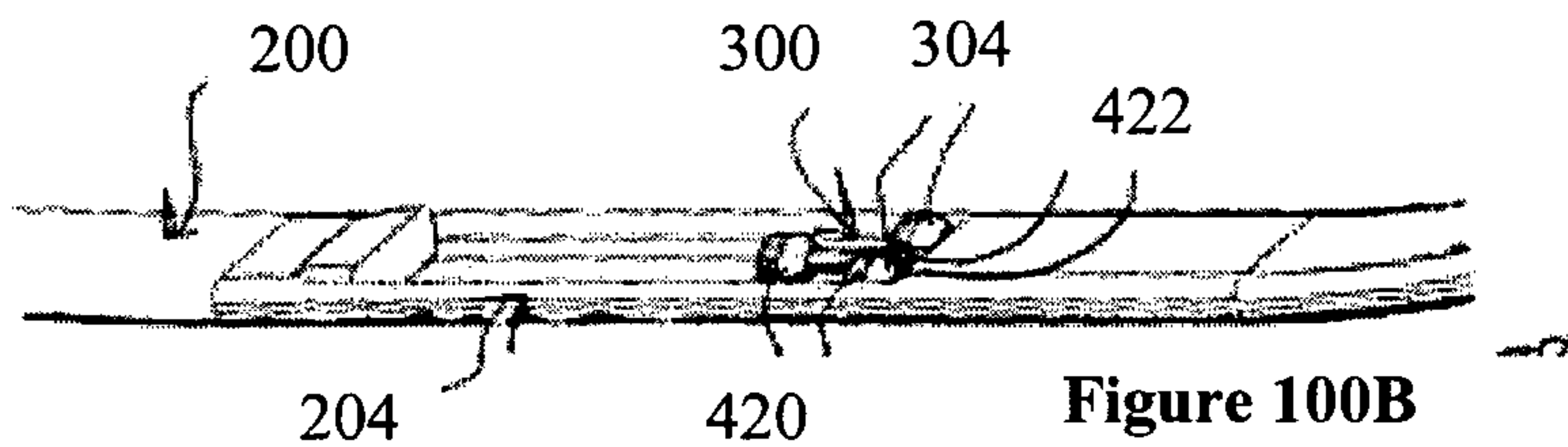
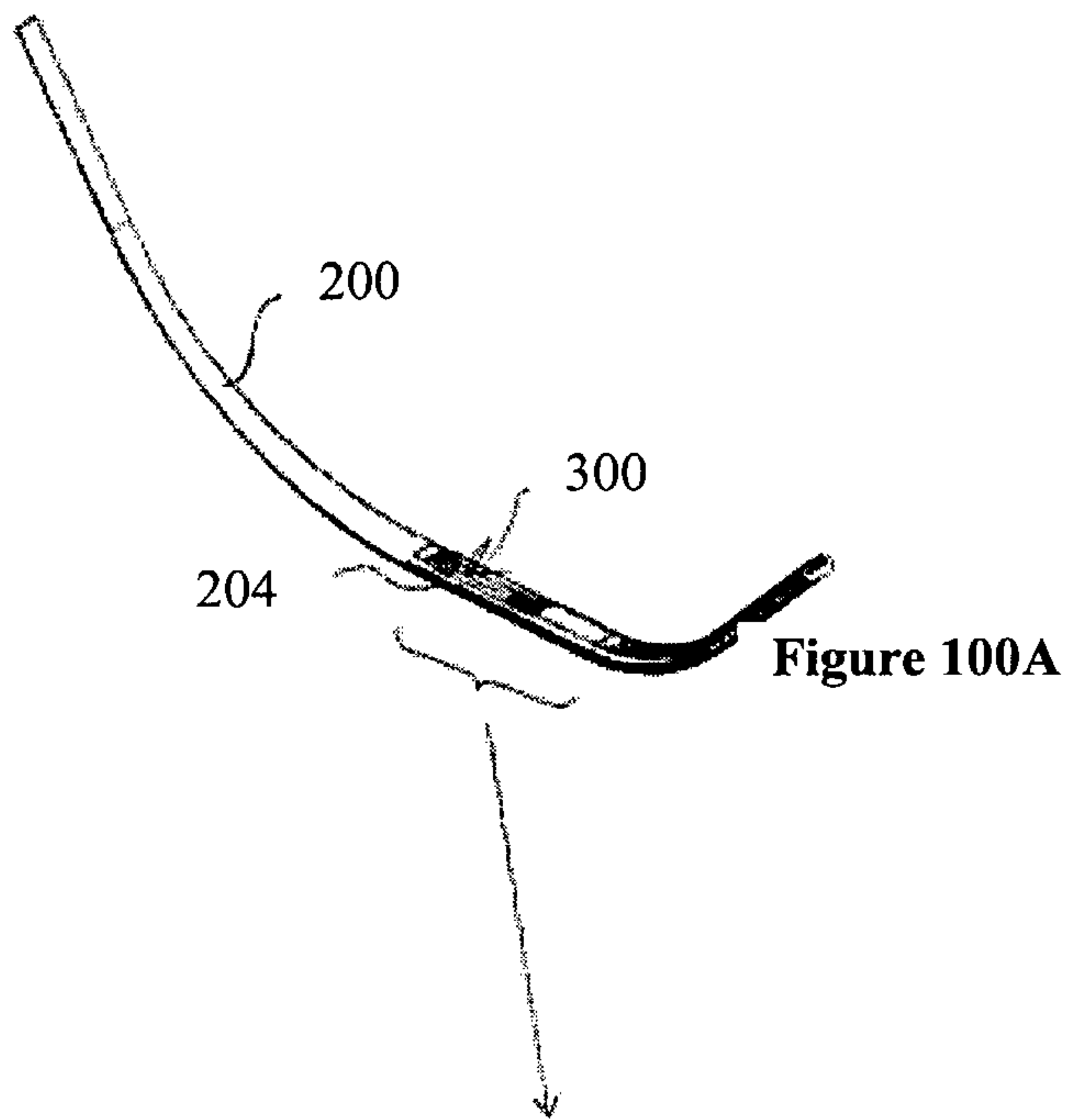

Figure 99B





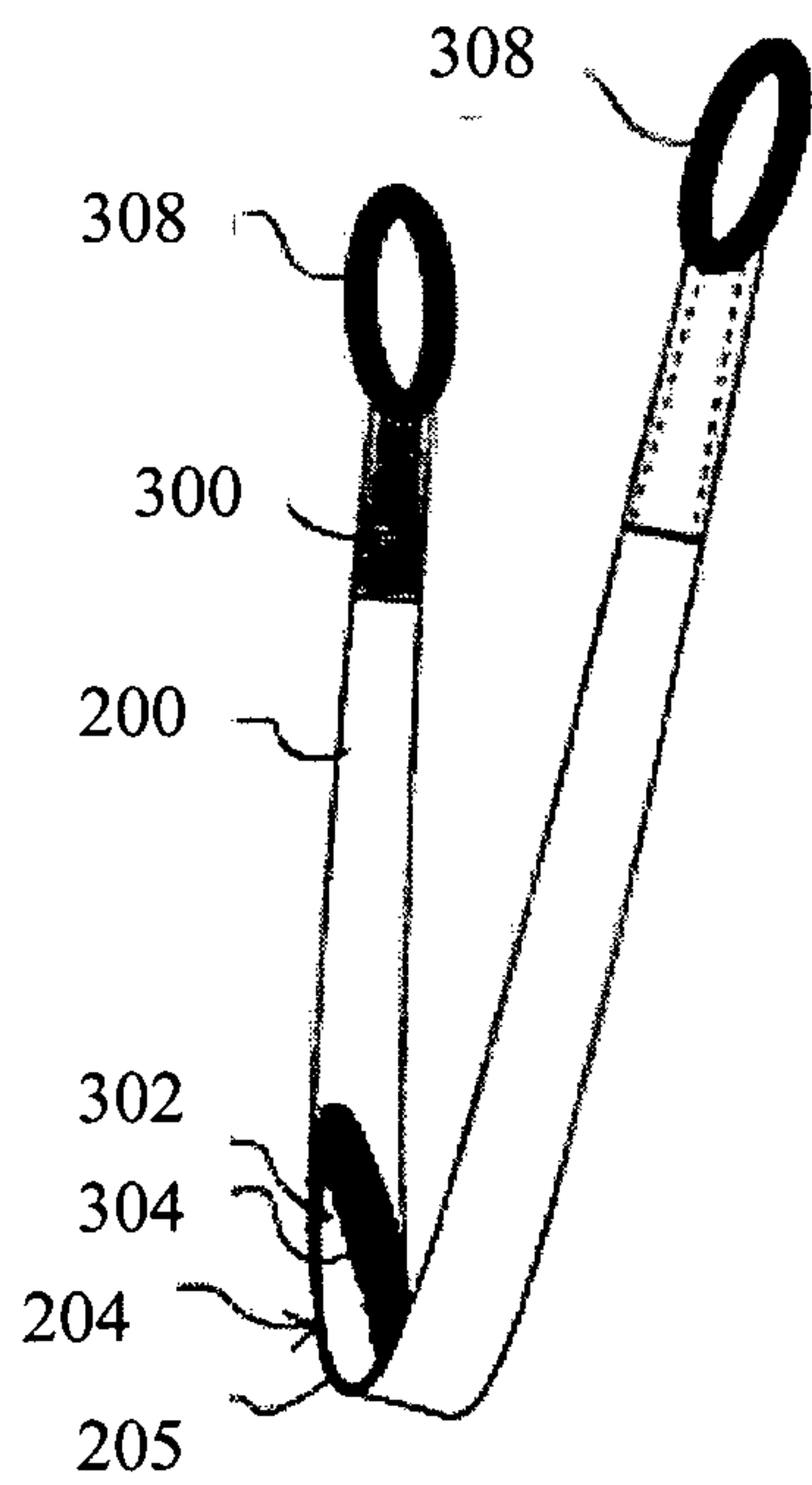

Figure 101

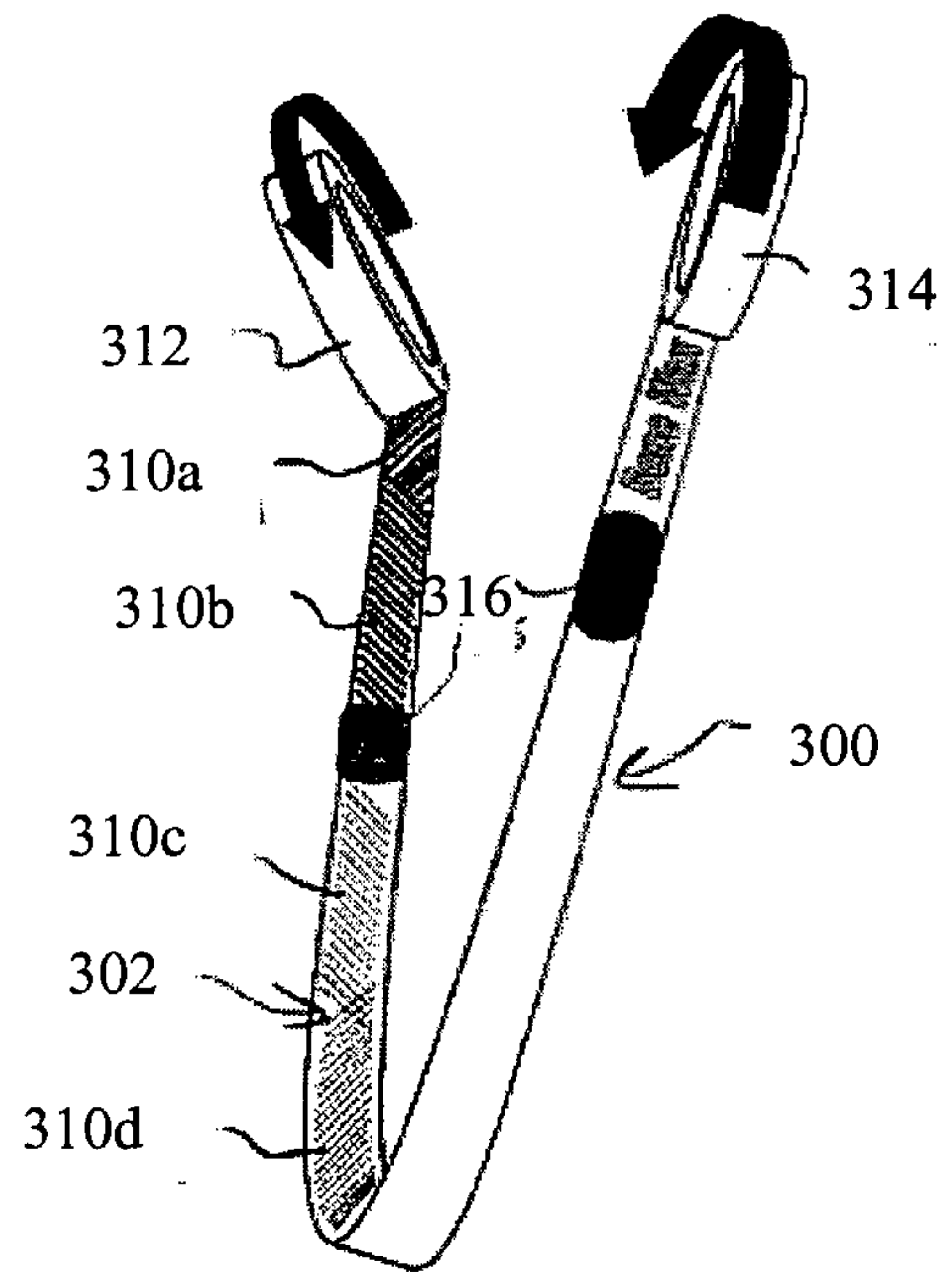

Figure 102



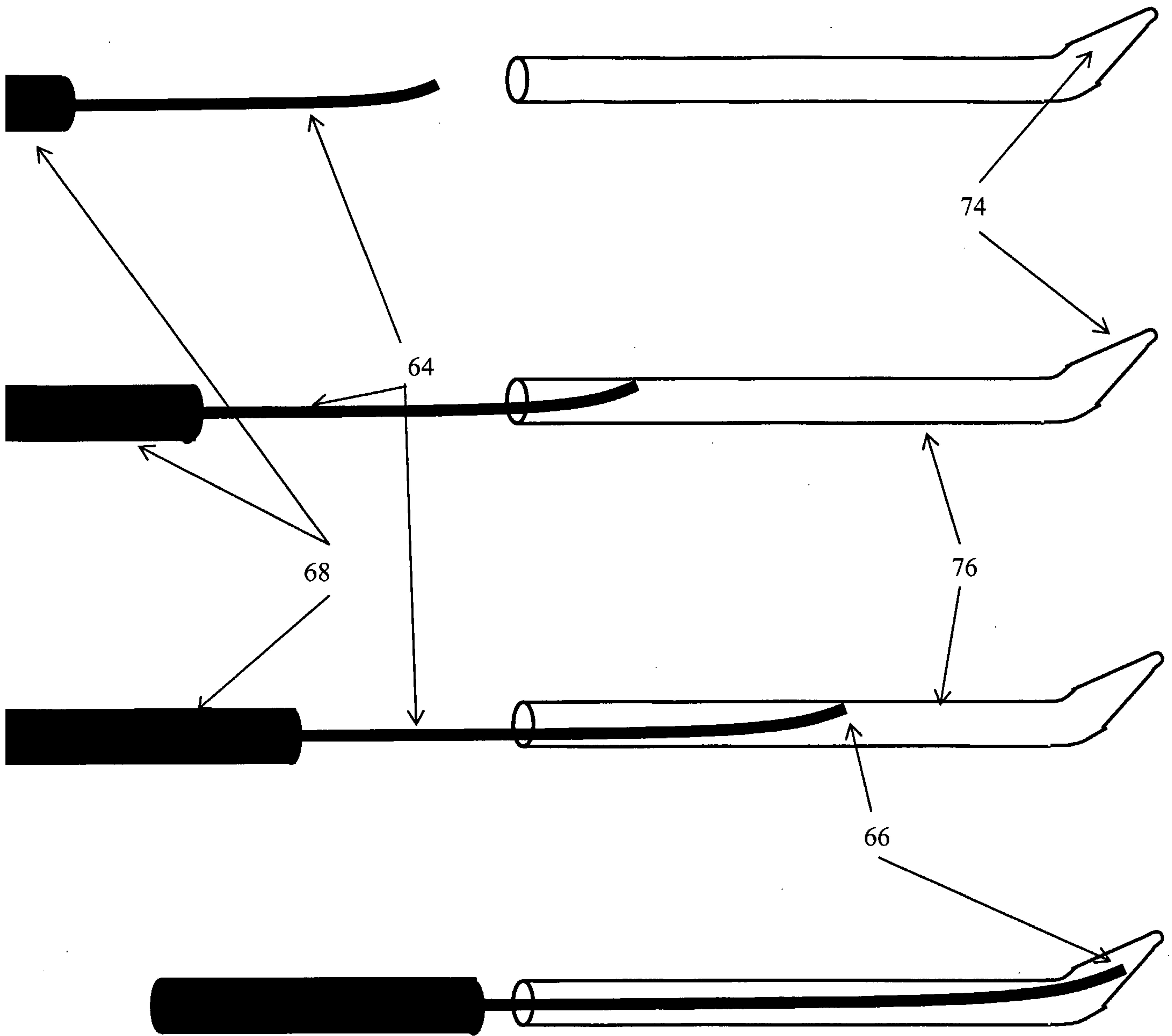
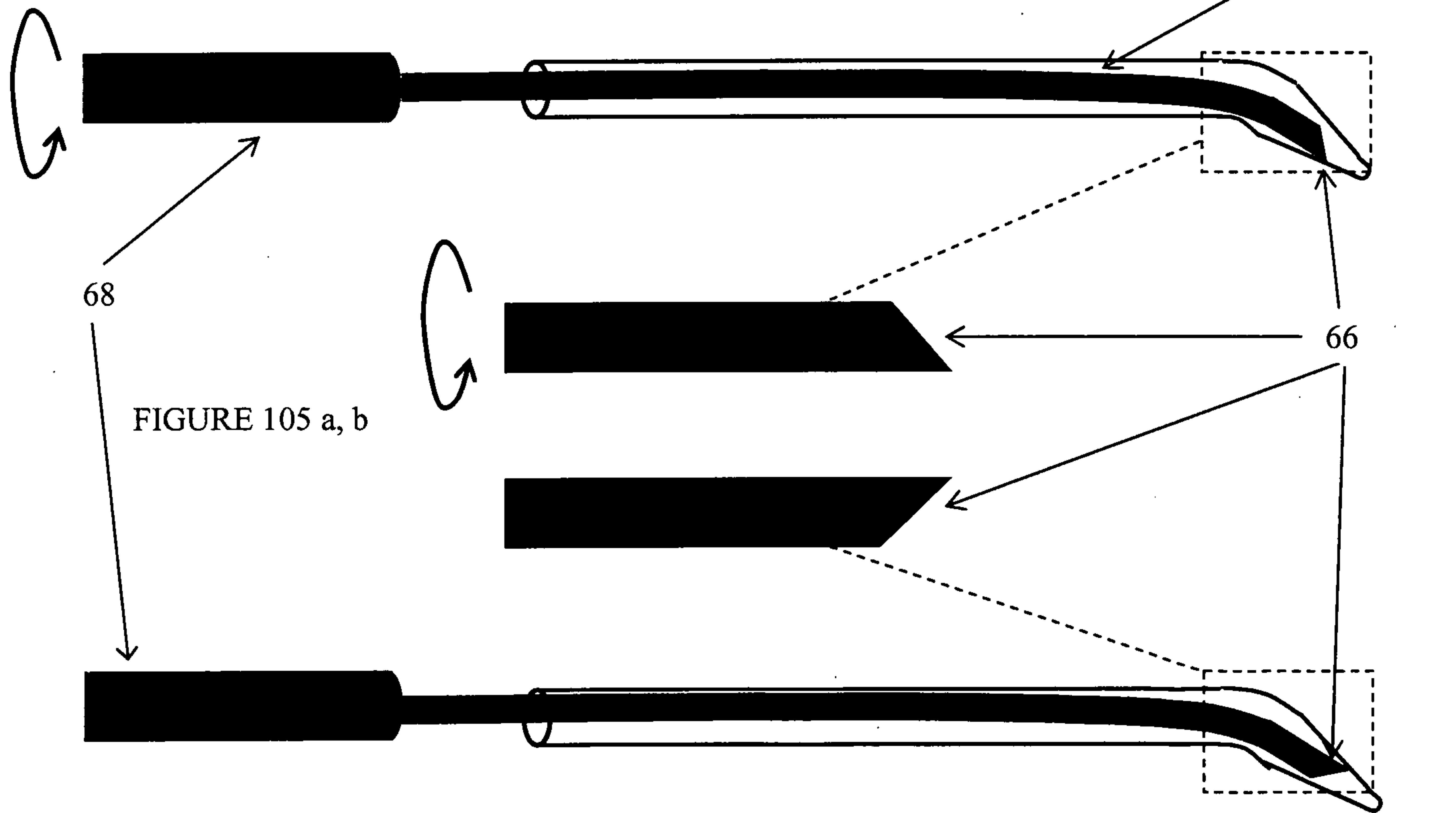
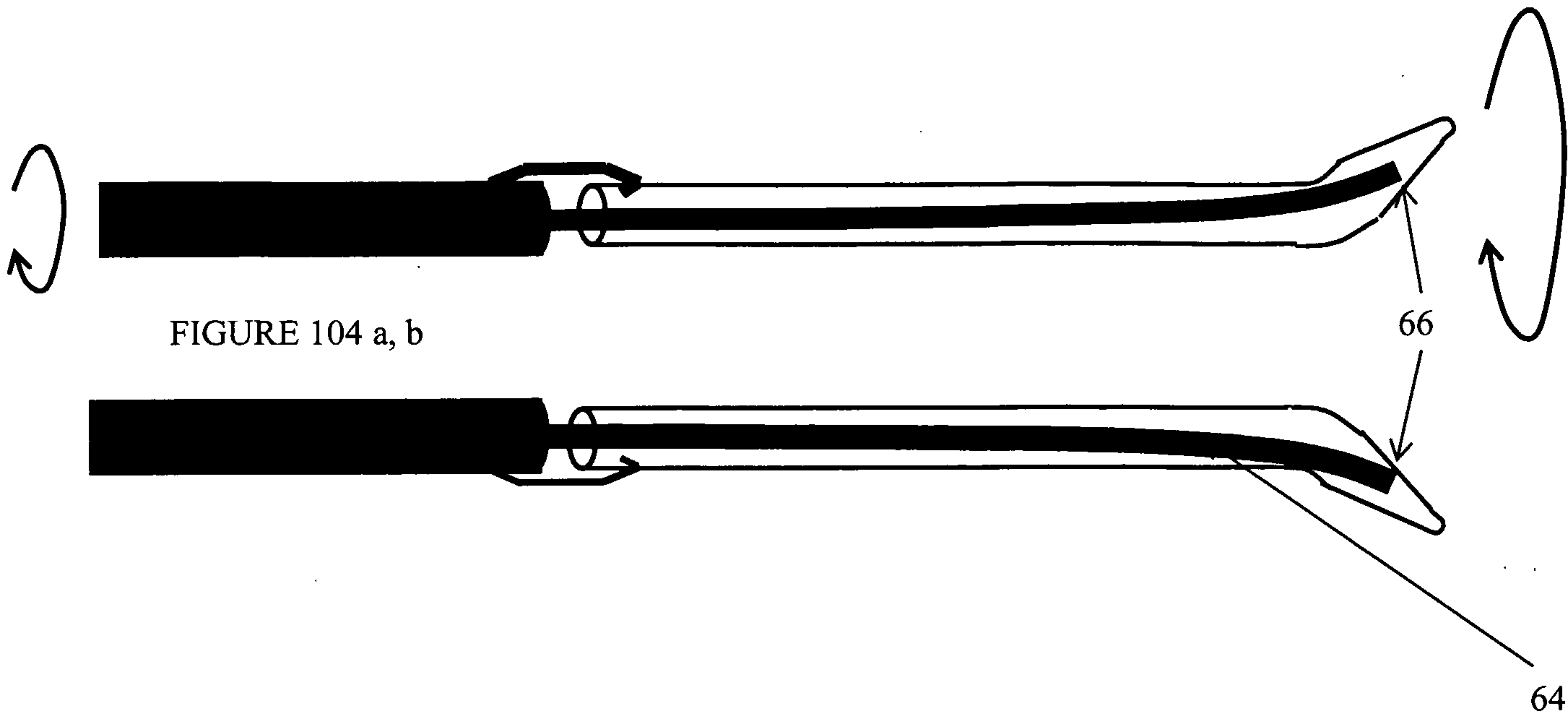

FIGURE 103 a, b, c, d





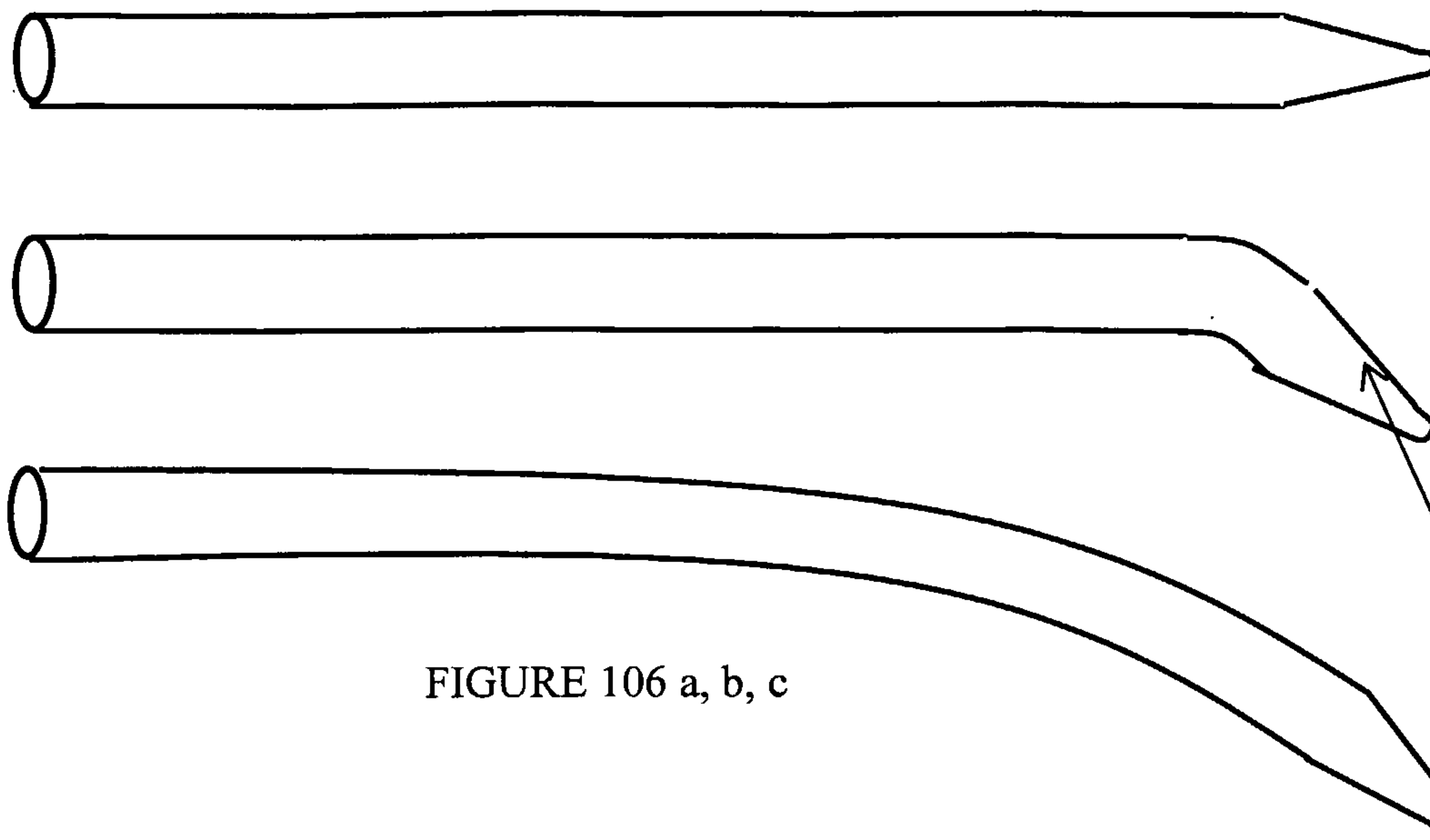

FIGURE 106 a, b, c

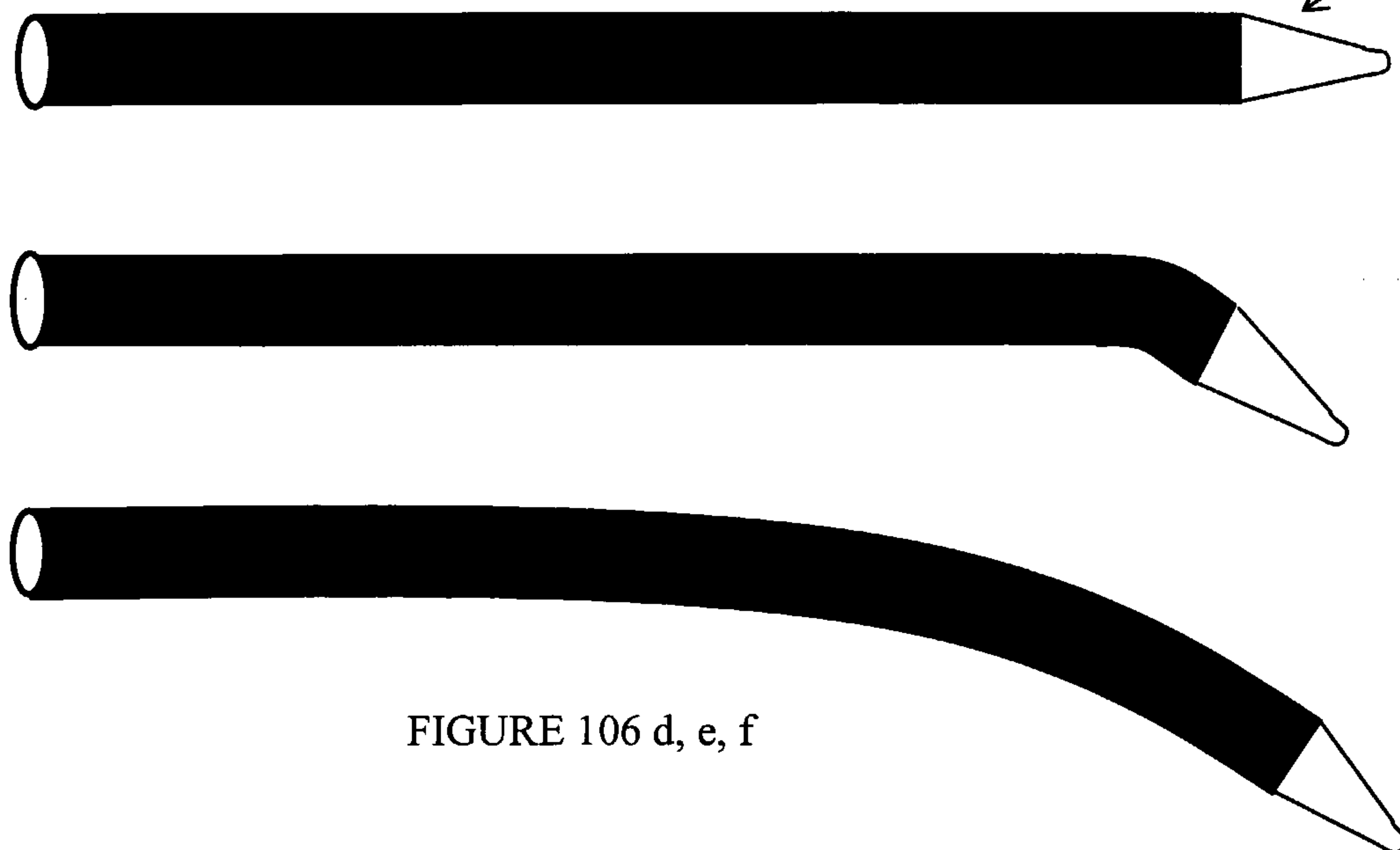

FIGURE 106 d, e, f

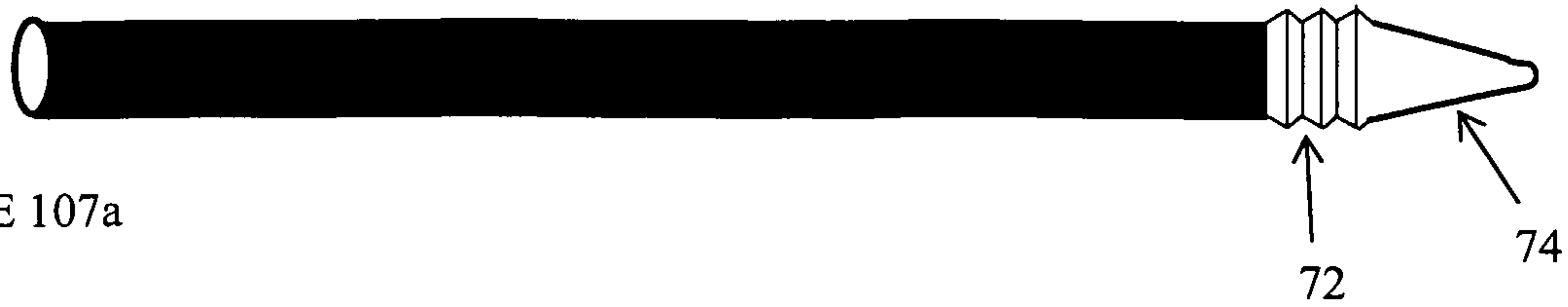

FIGURE 107a



FIGURE 107b



FIGURE 107c



FIGURE 107d

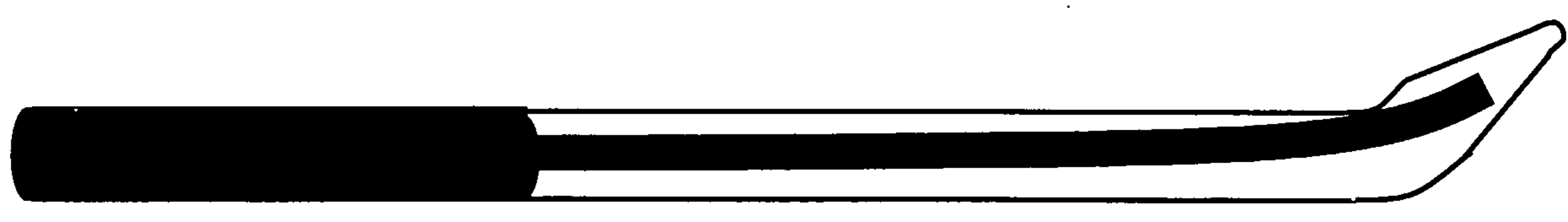

FIGURE 108



FIGURE 109a



FIGURE 109b

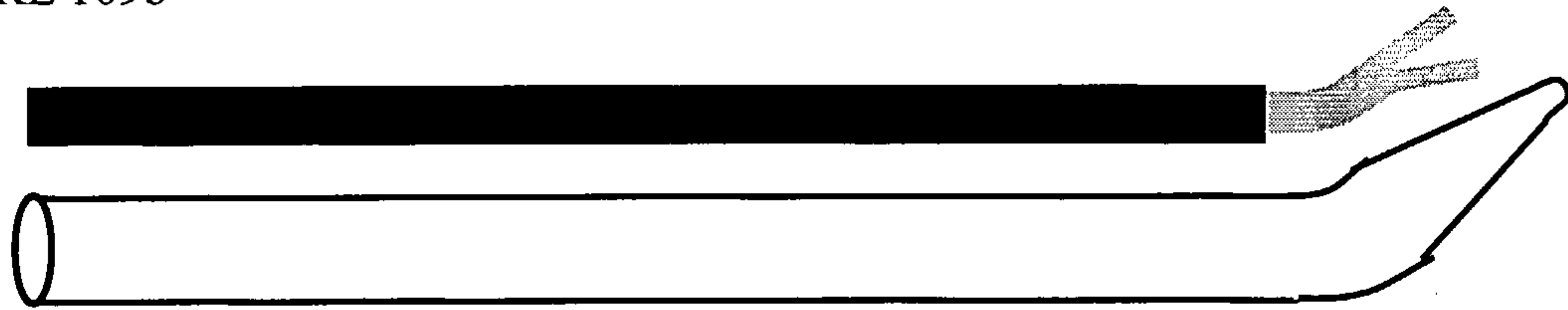

FIGURE 110a

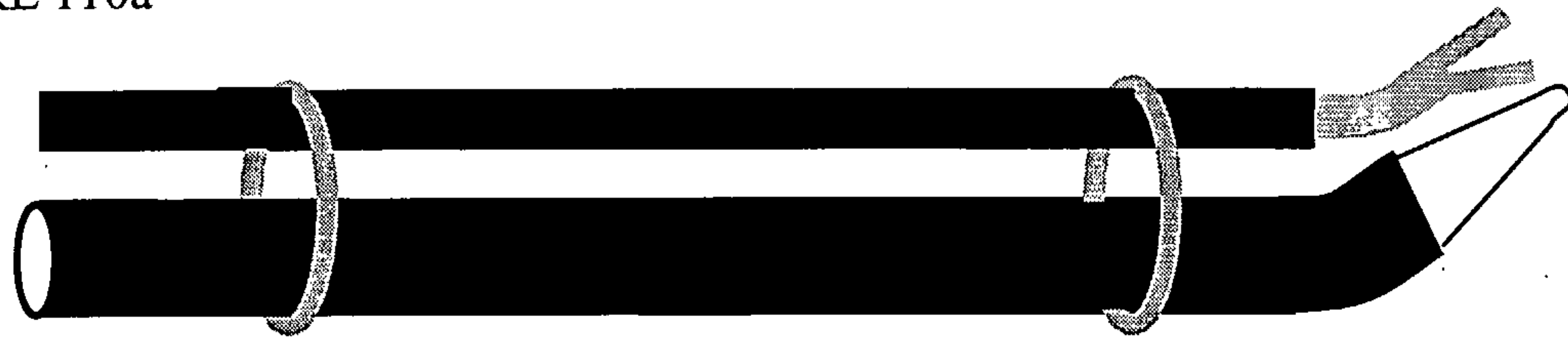

FIGURE 110b

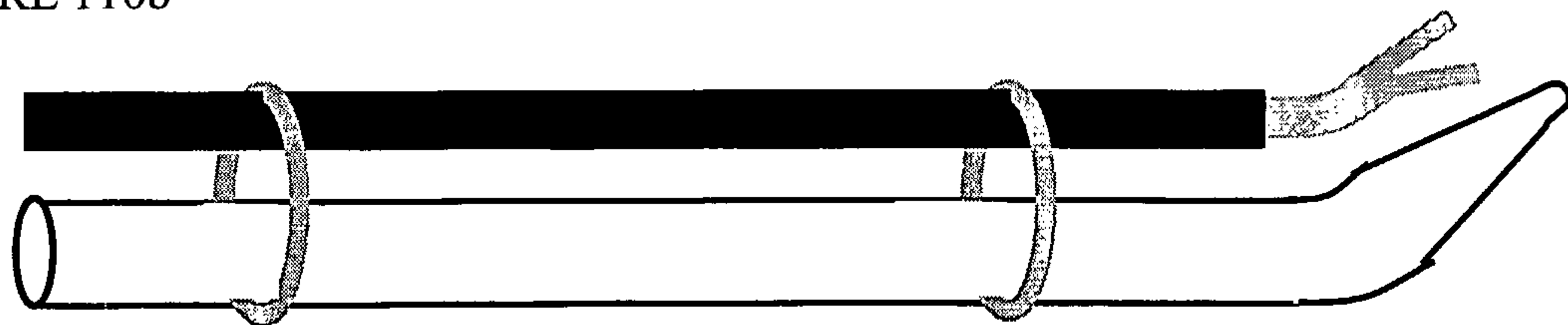

FIGURE 111a

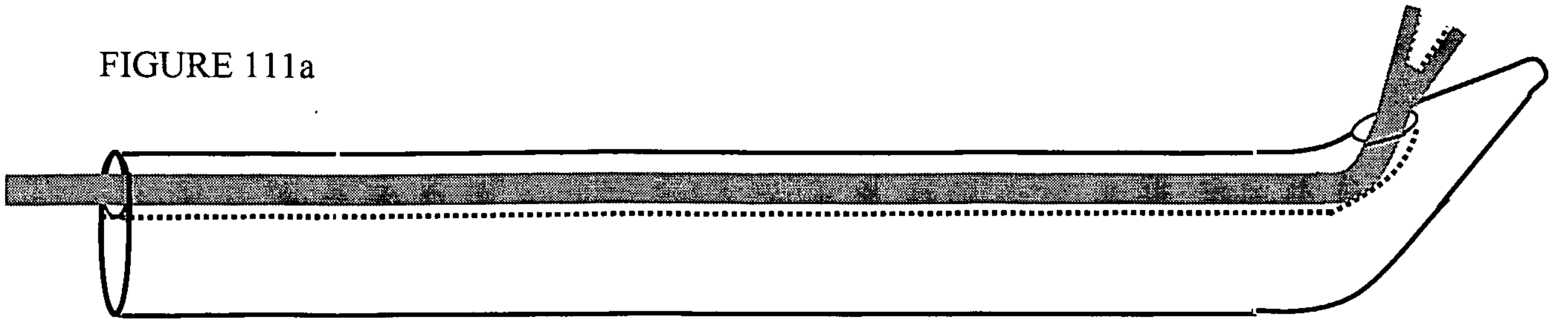

FIGURE 111b

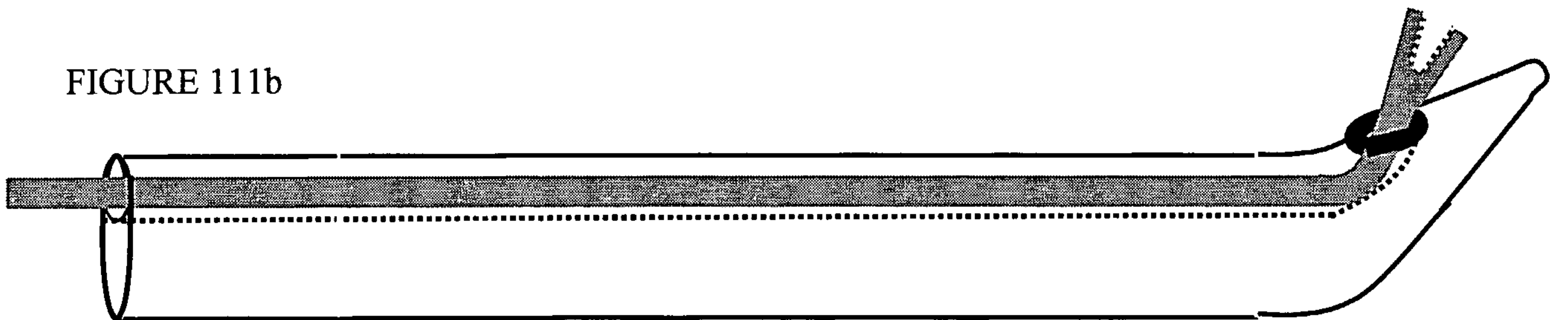

FIGURE 112a

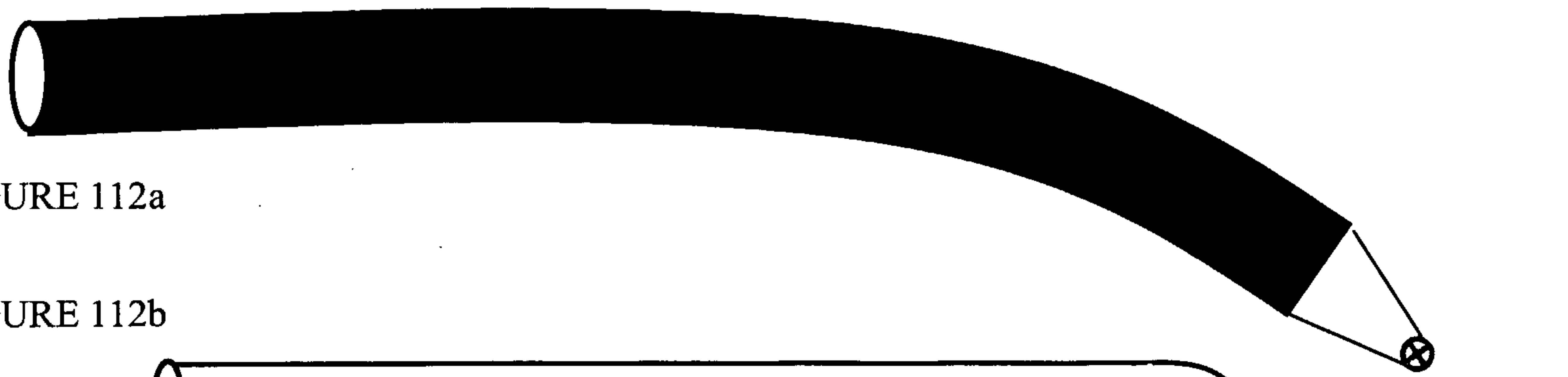

FIGURE 112b

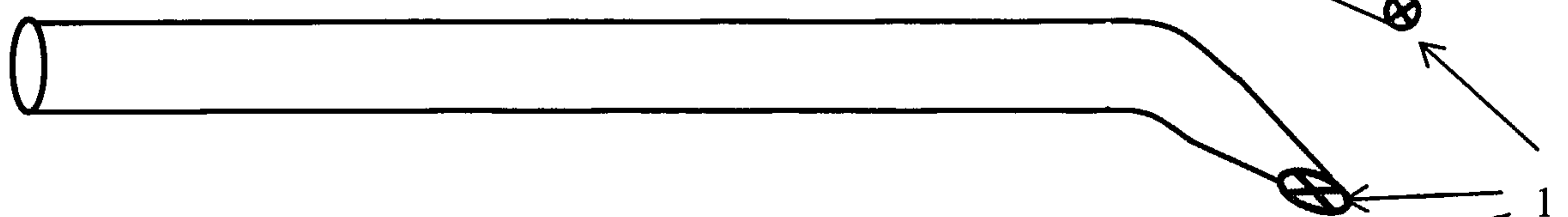

FIGURE 112c





FIGURE 113a

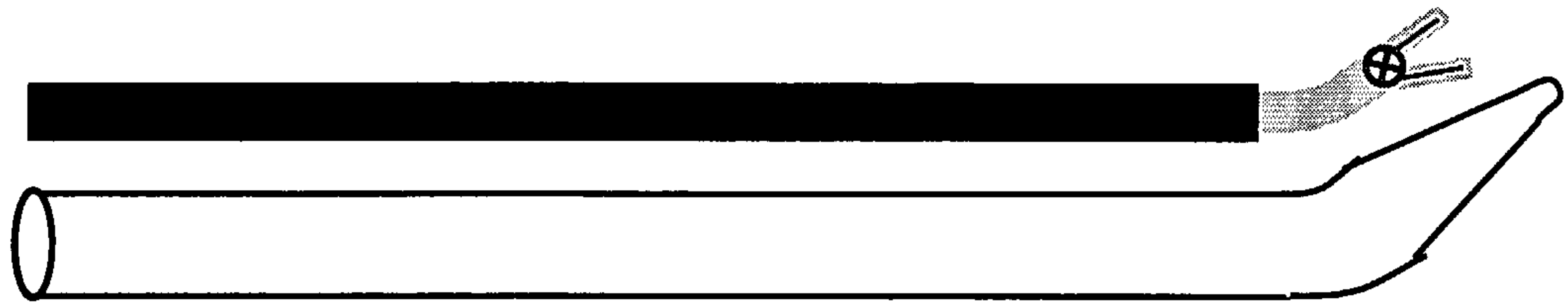

FIGURE 113b

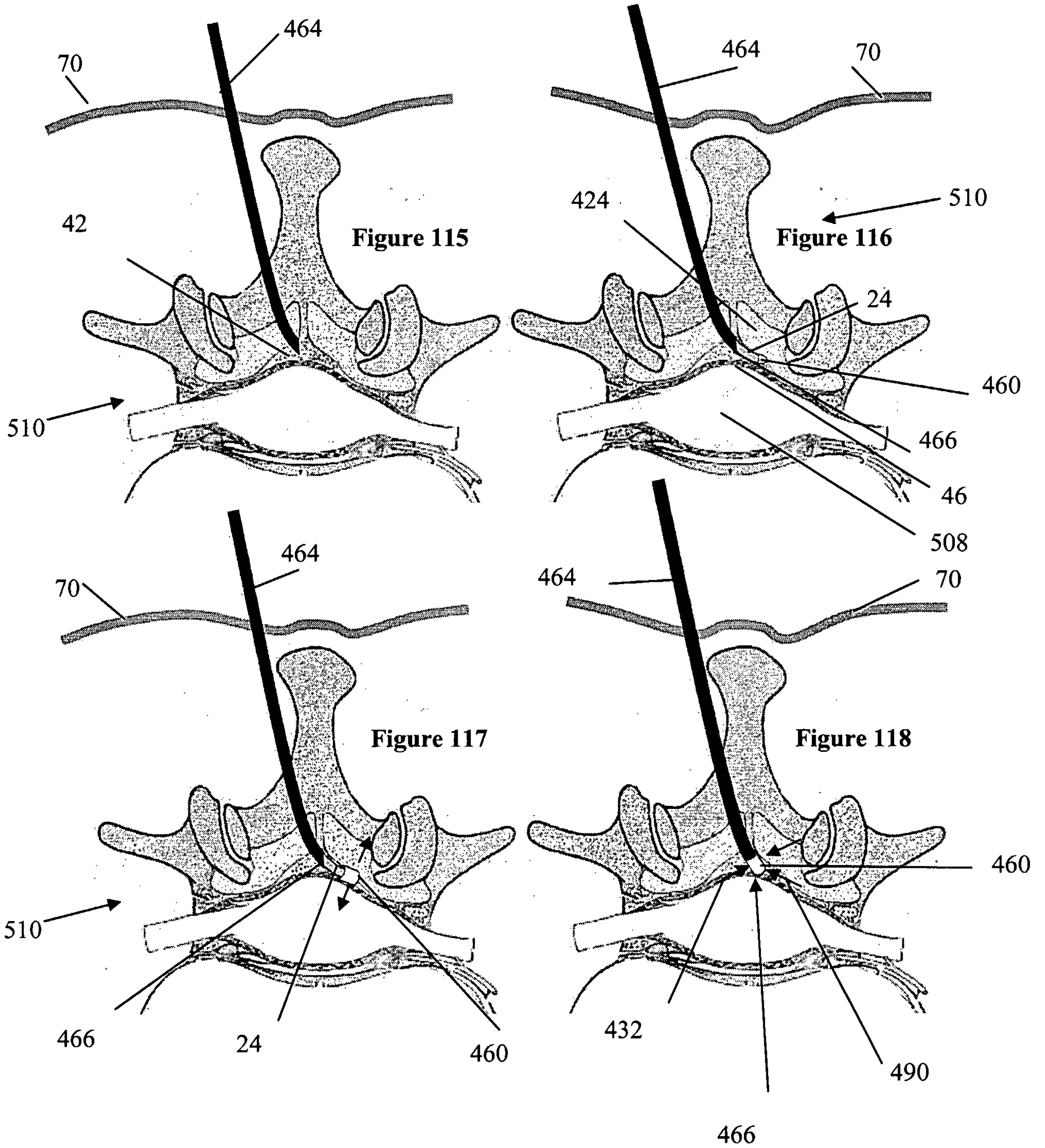

FIGURE 114a

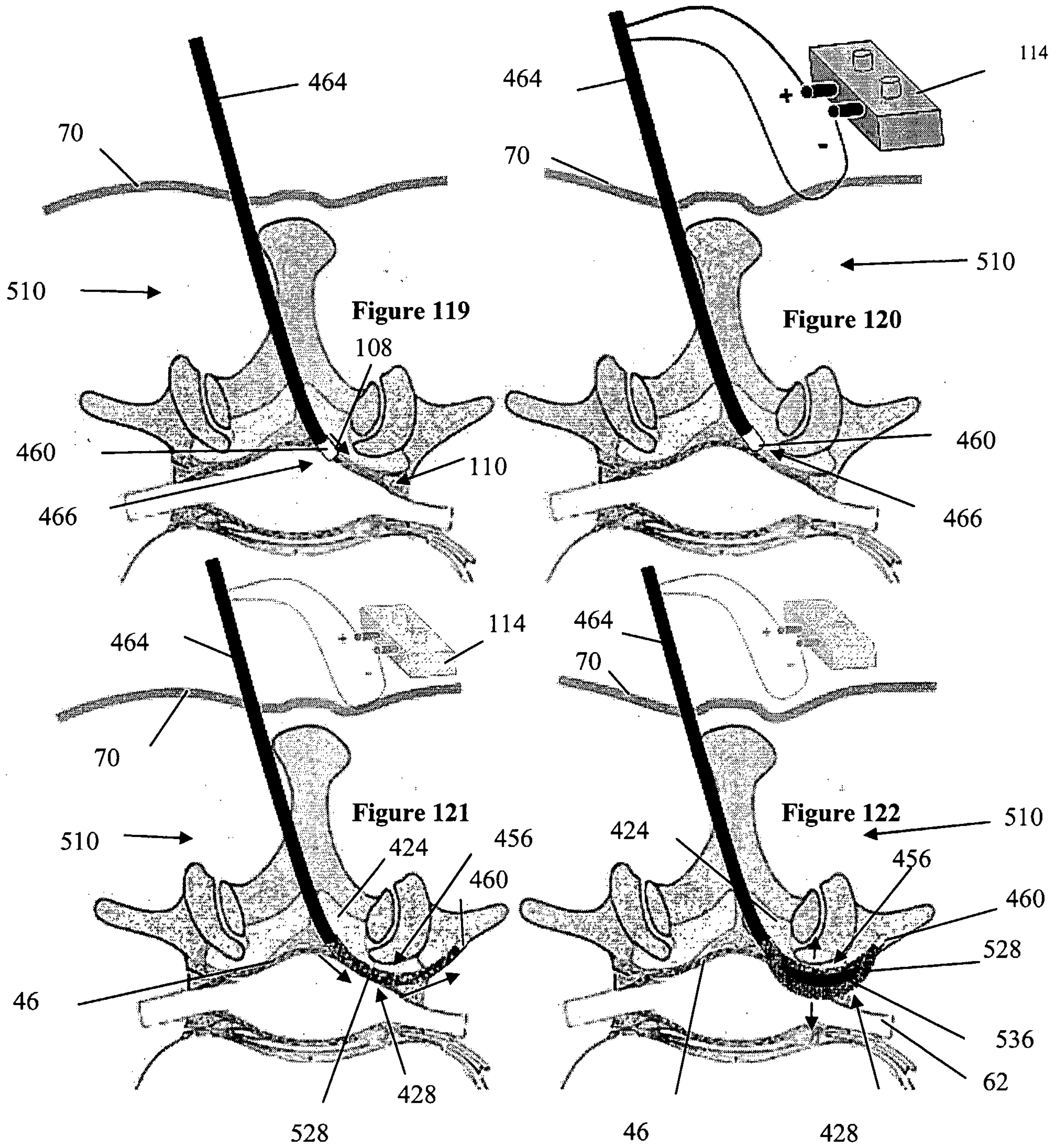

FIGURE 114b

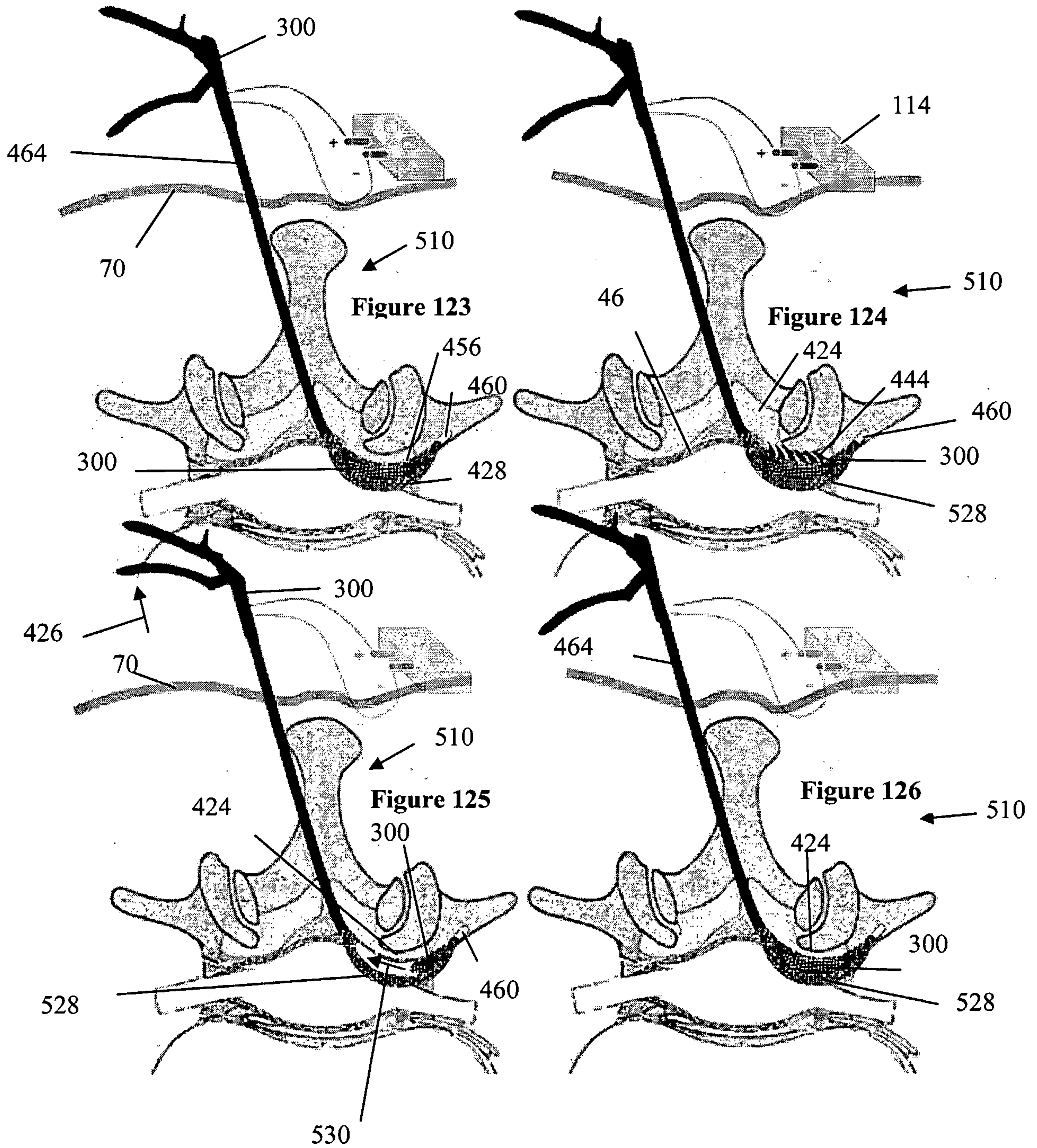



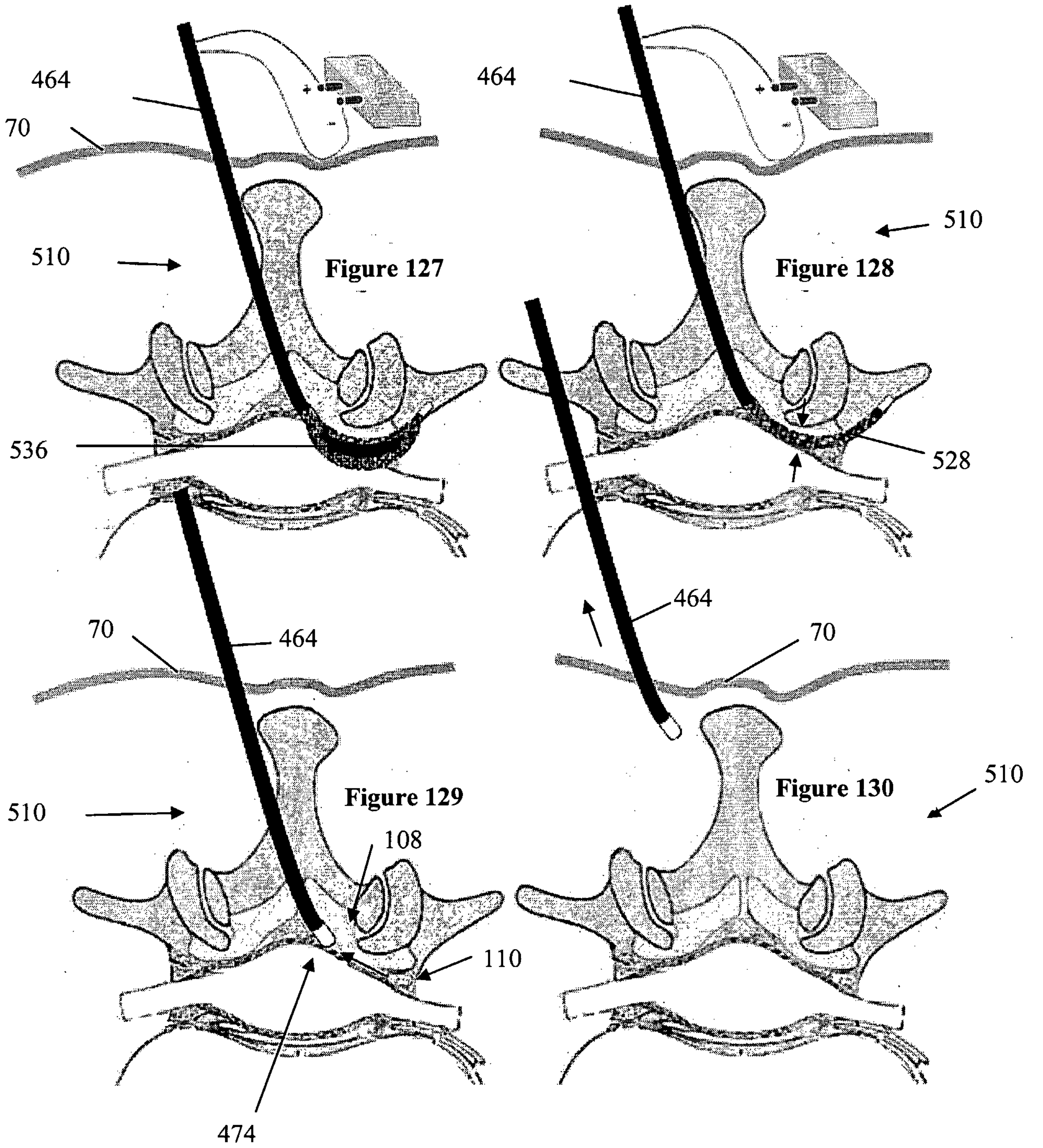











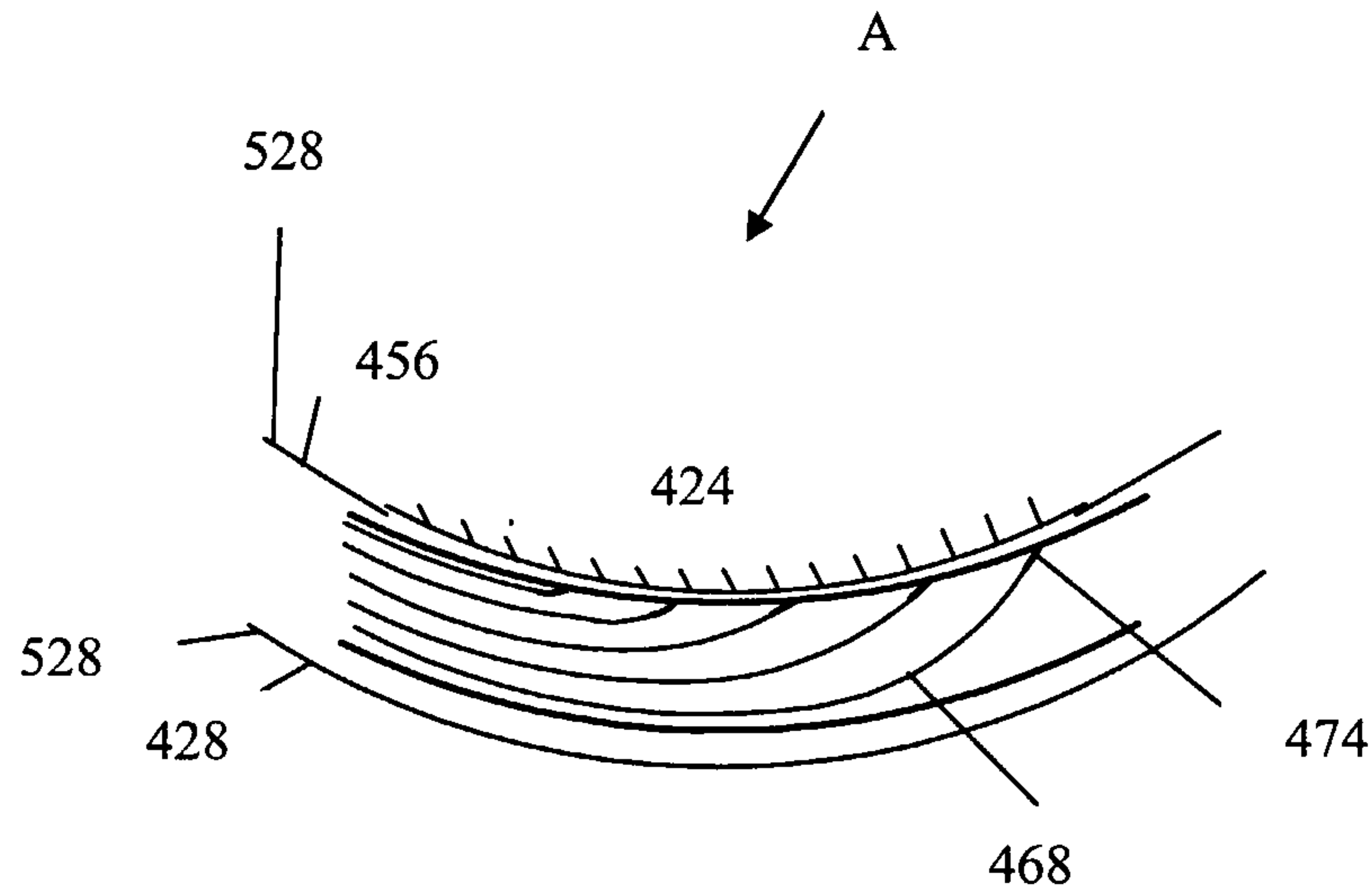

Figure 131

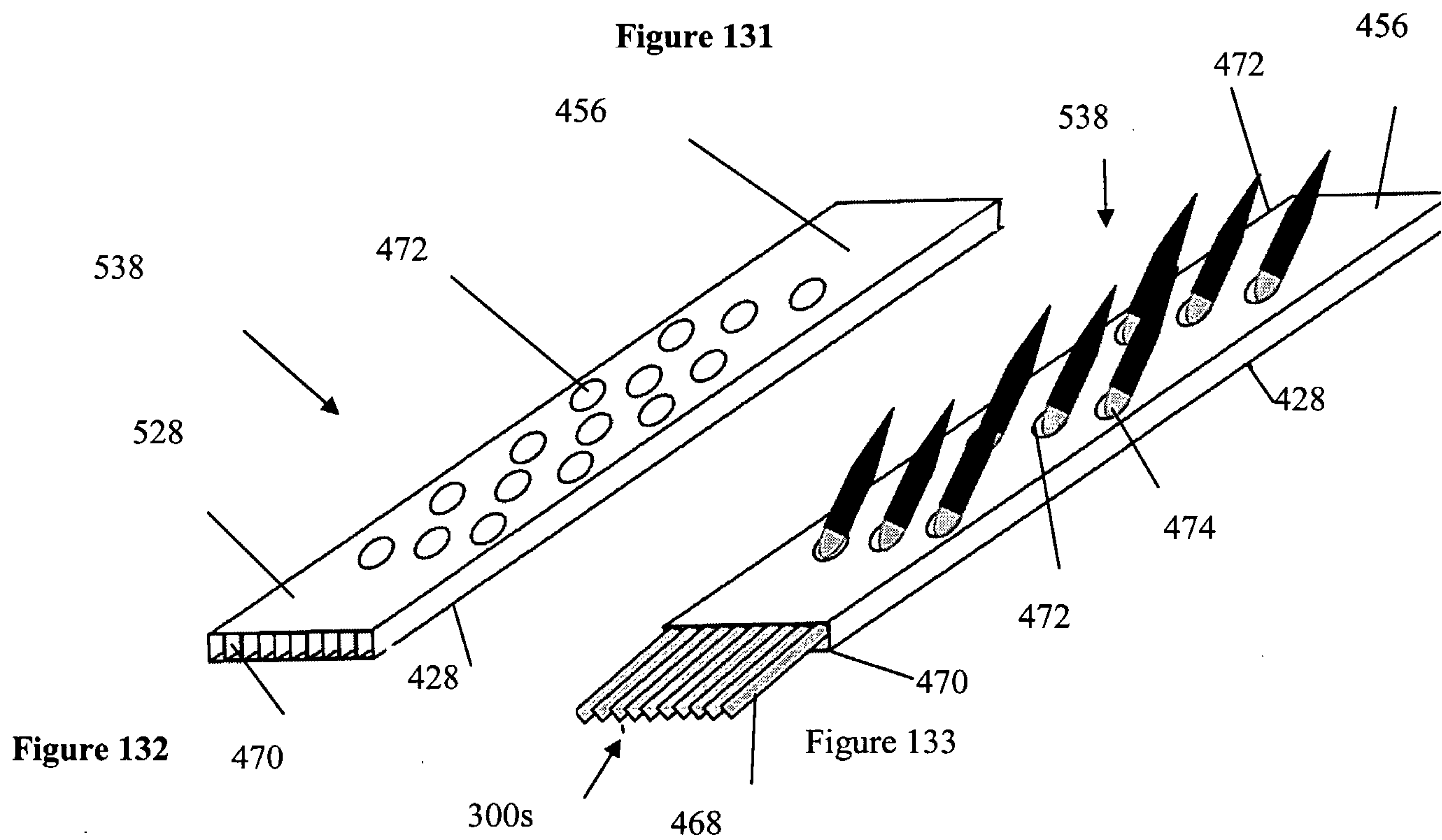

Figure 132

Figure 133



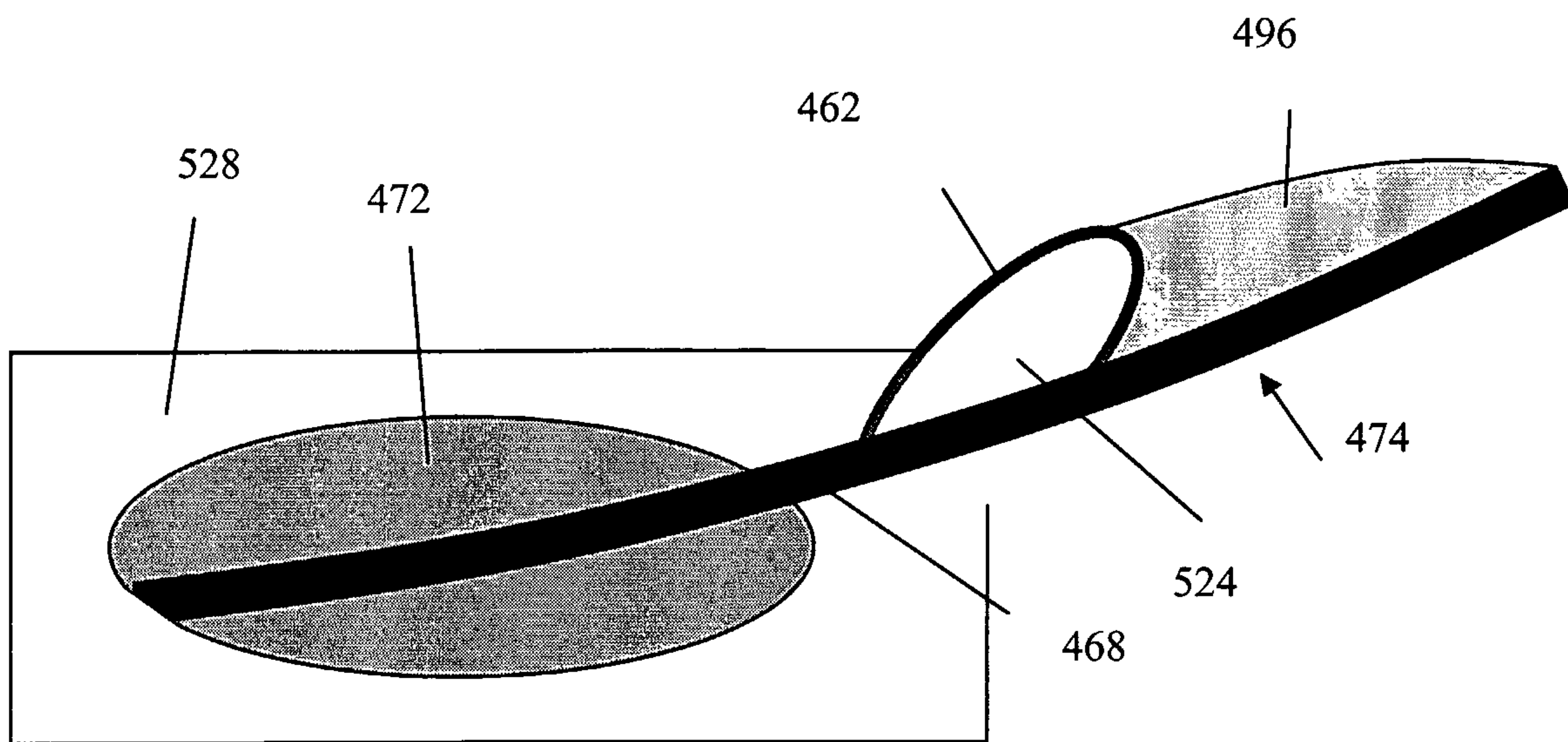

Fig. 134

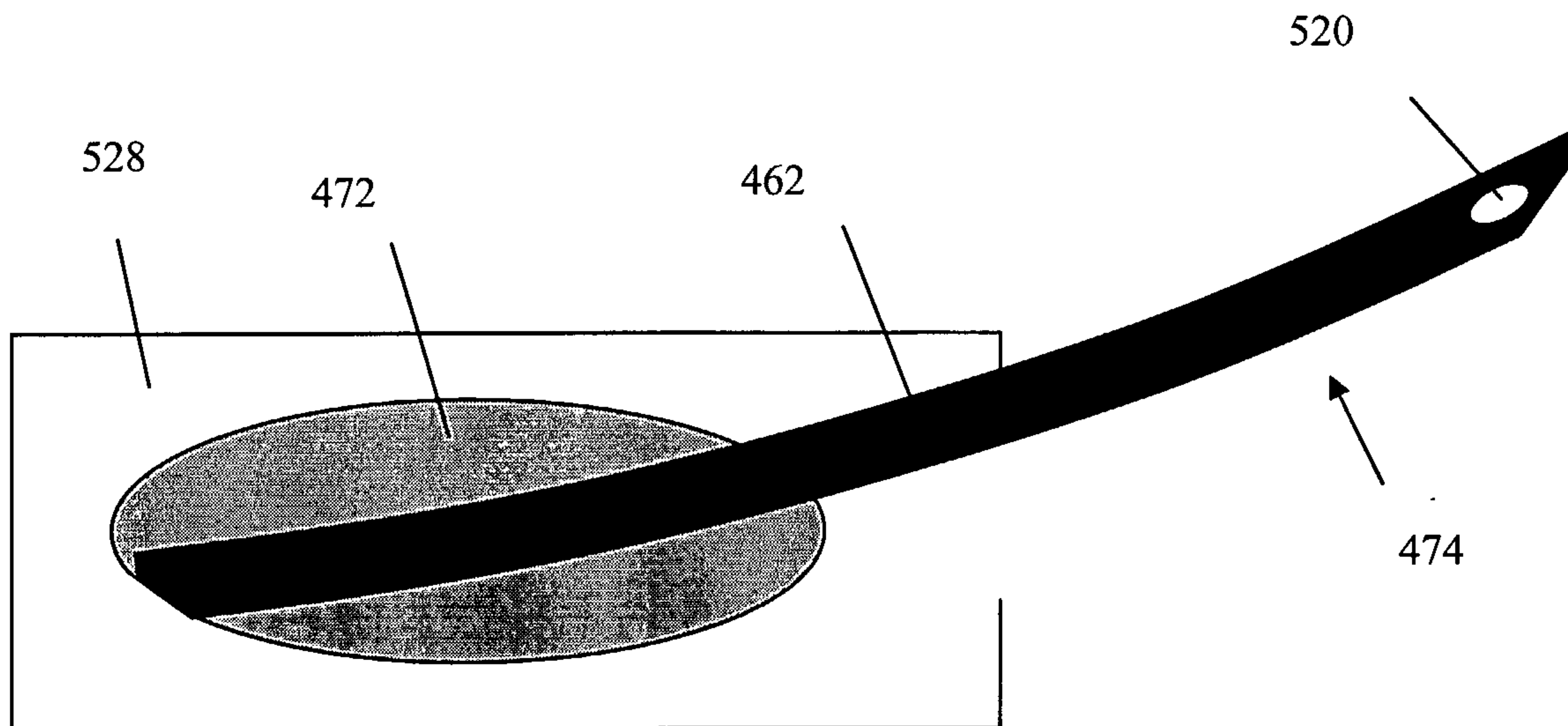

Fig. 135



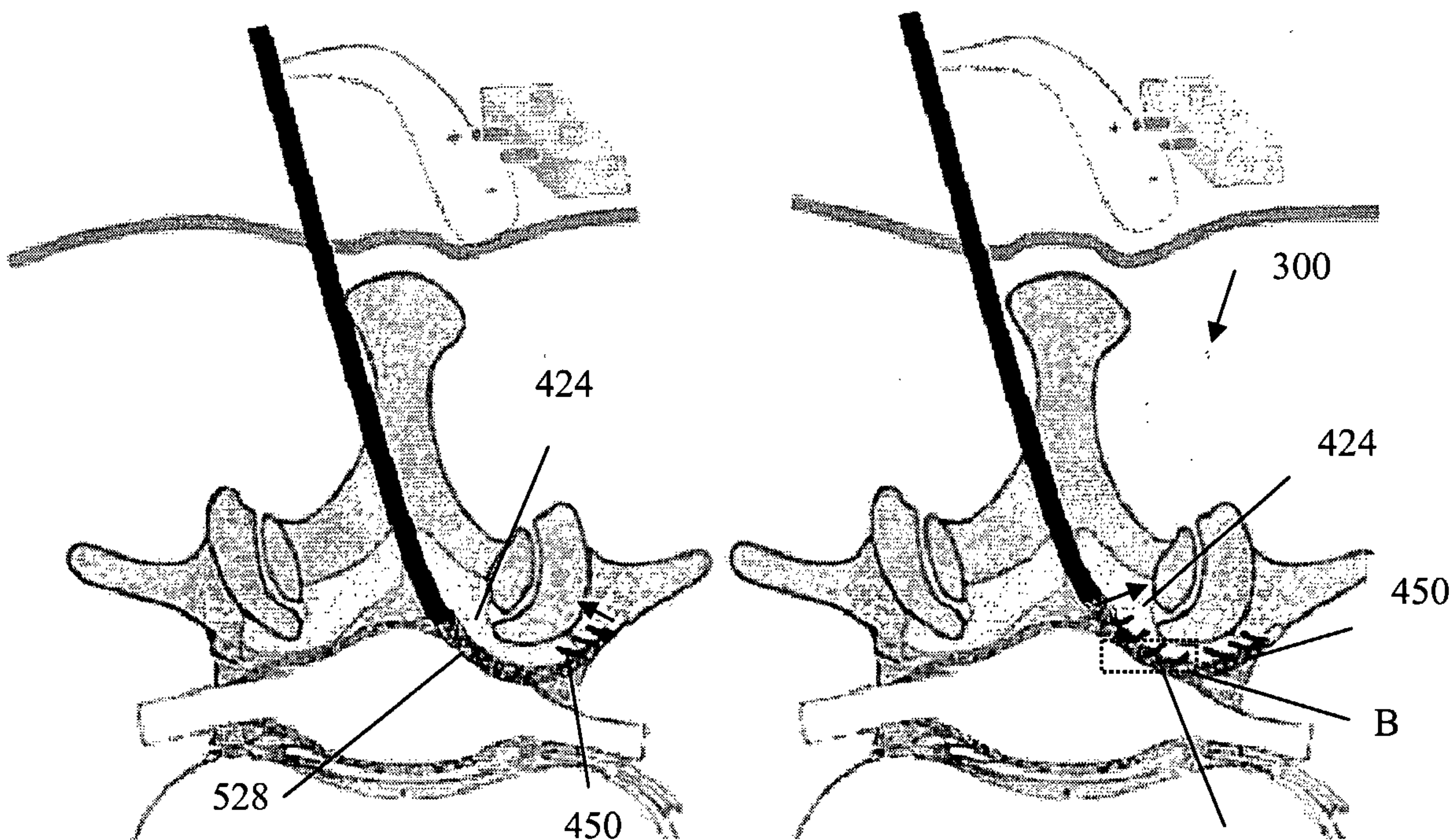

Figure 136

Figure 137

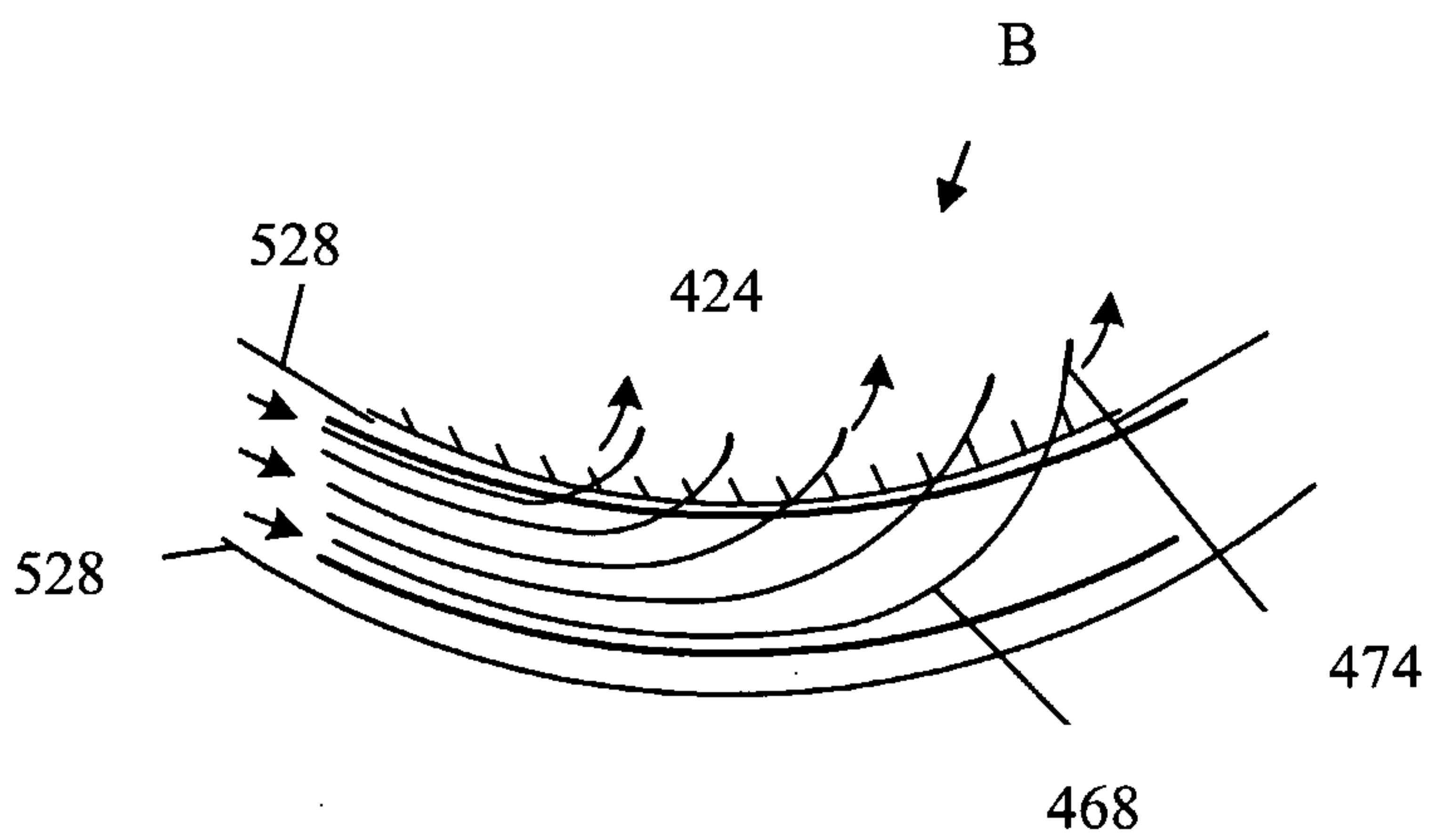

Figure 138

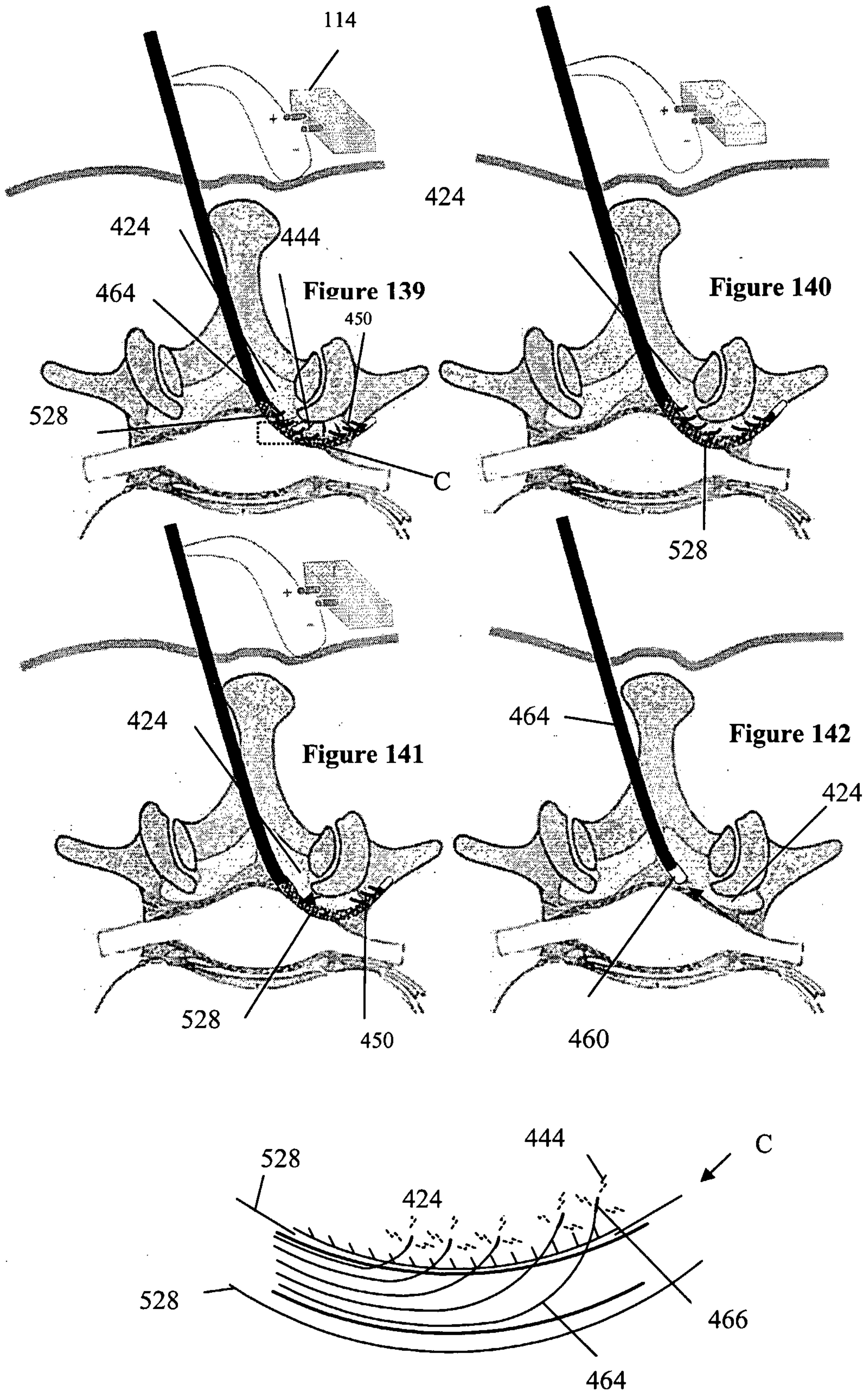

Figure 143



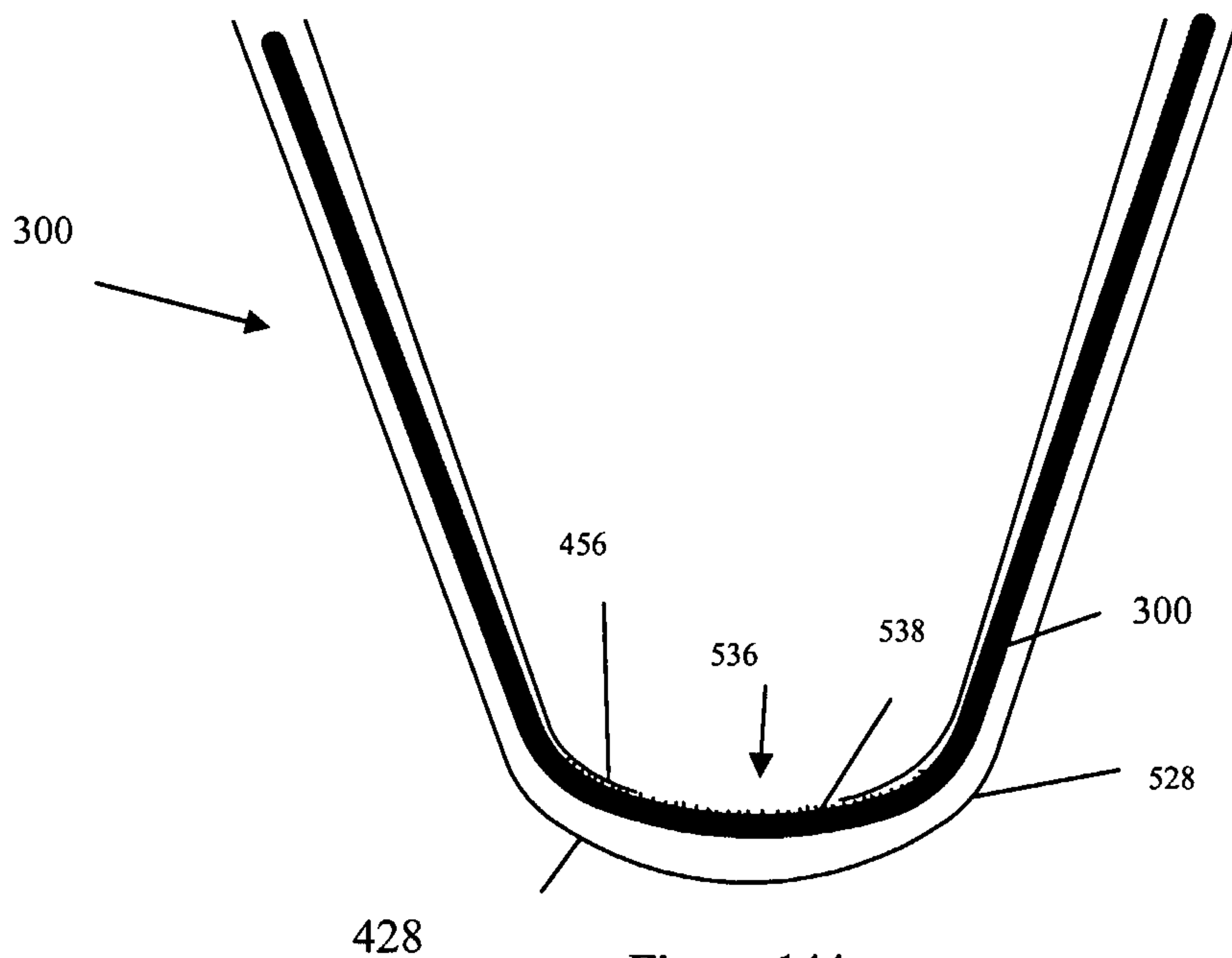

Figure 144

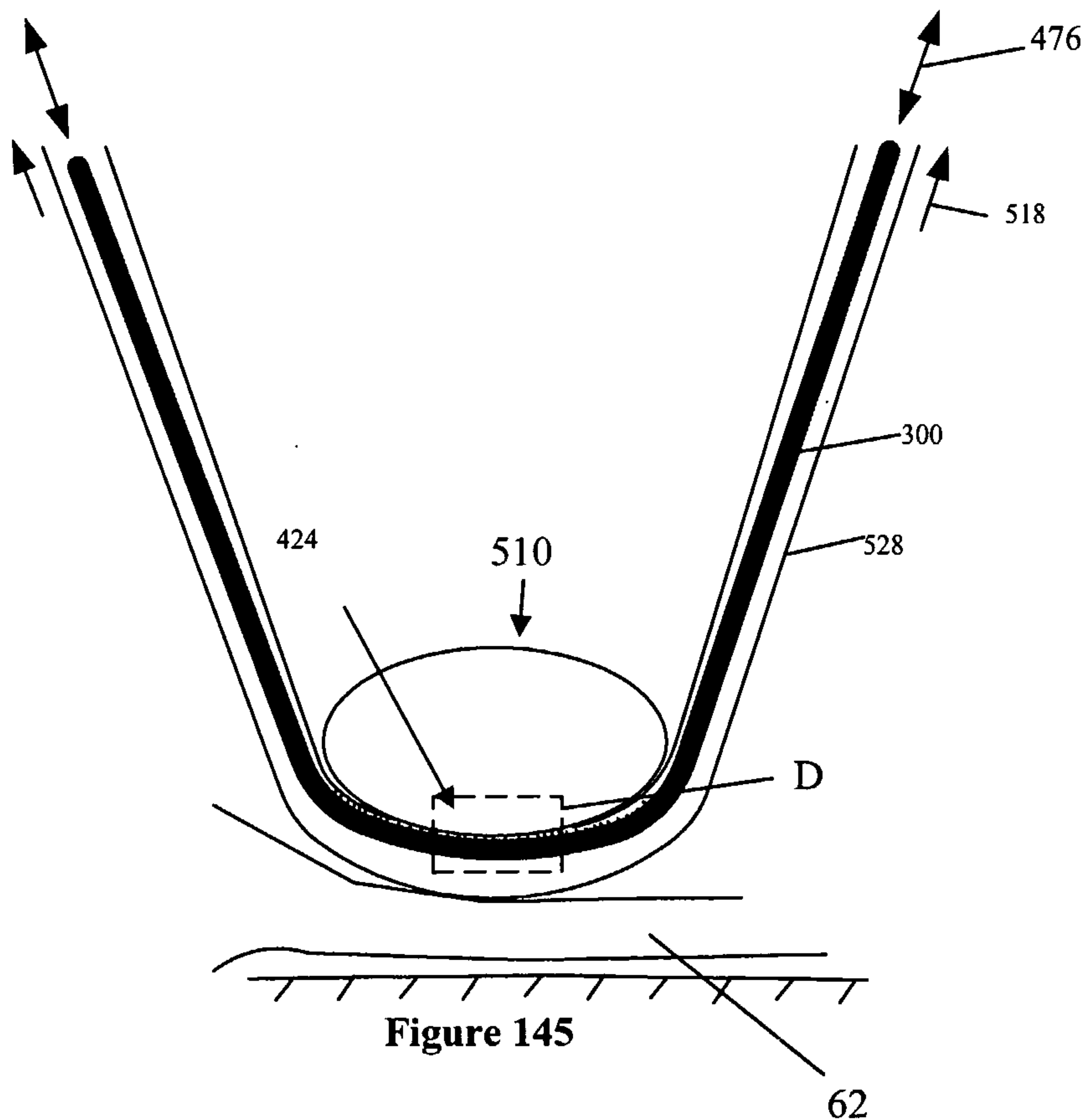

Figure 145



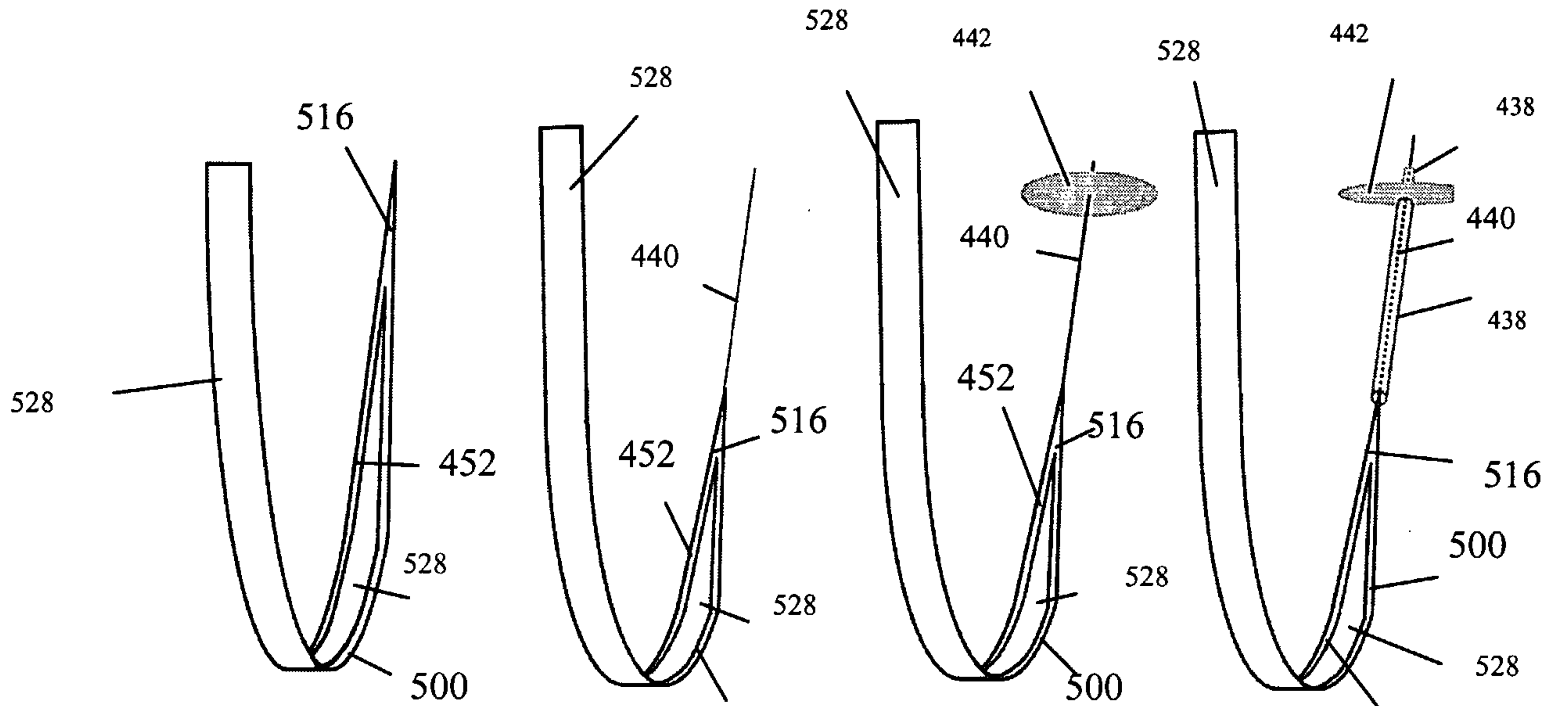

Fig. 146

Fig. 147

Fig. 148

Fig. 149

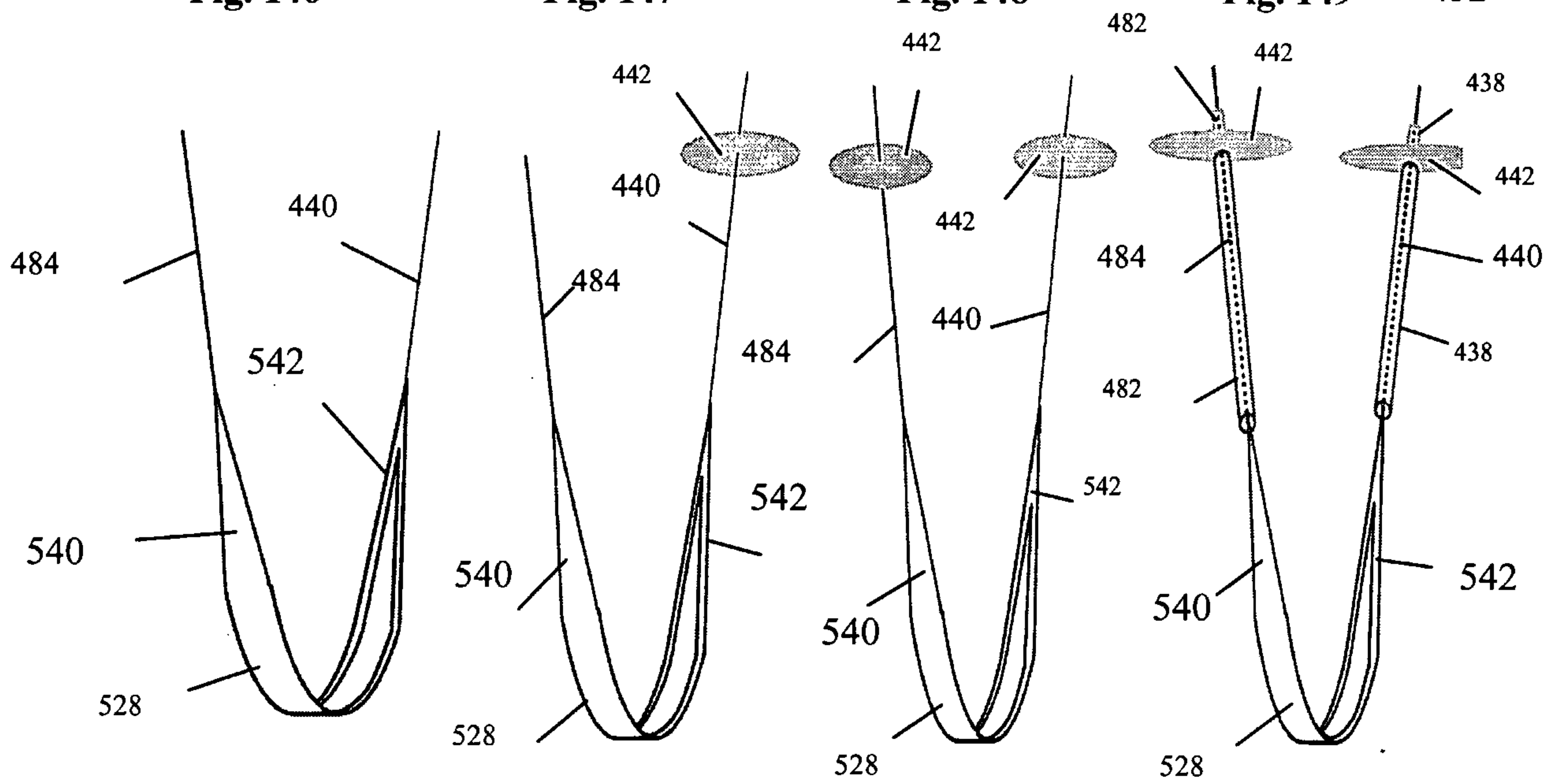

Fig. 150

Fig. 151

Fig. 152

Fig. 153

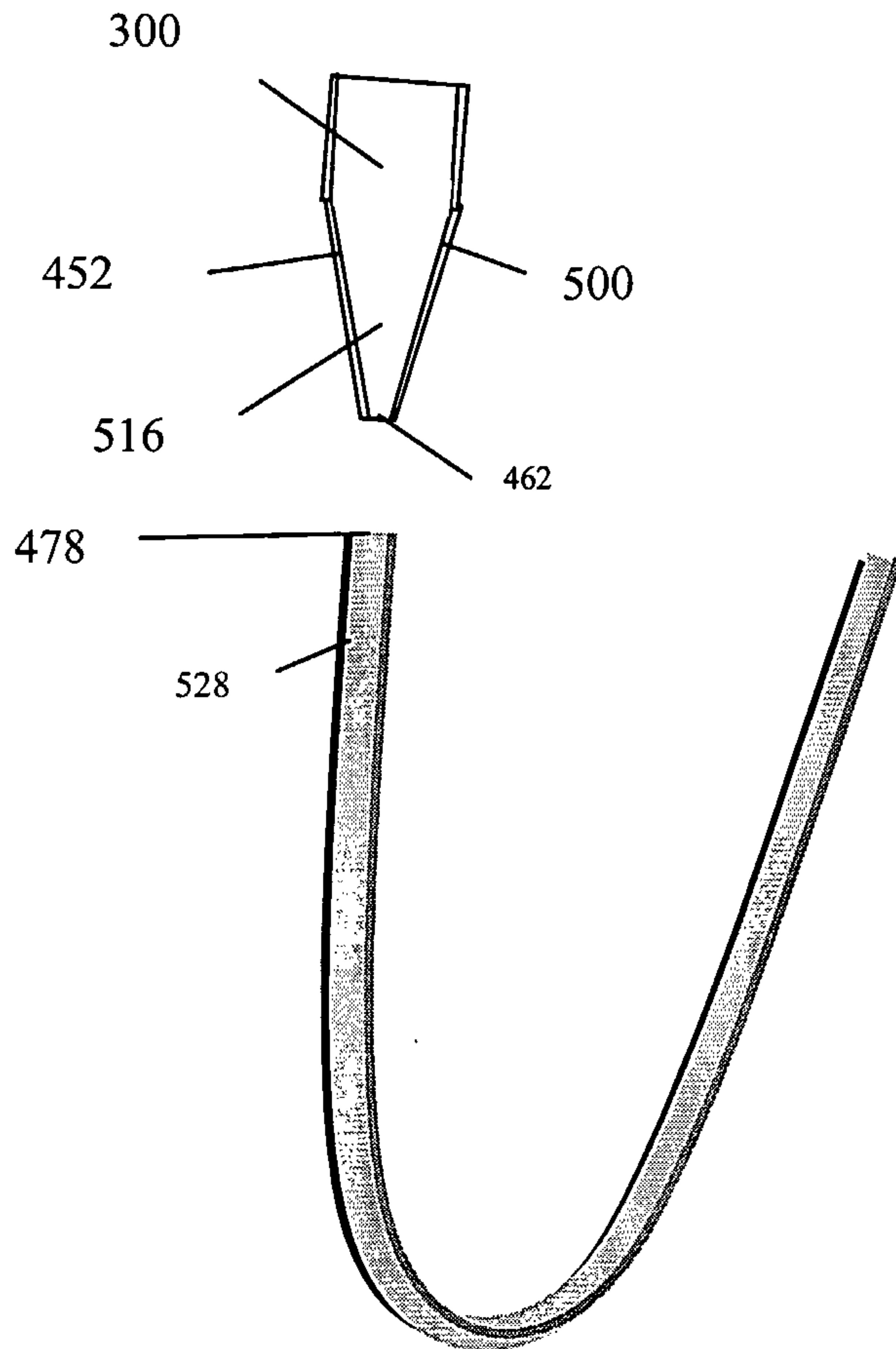

Fig. 154

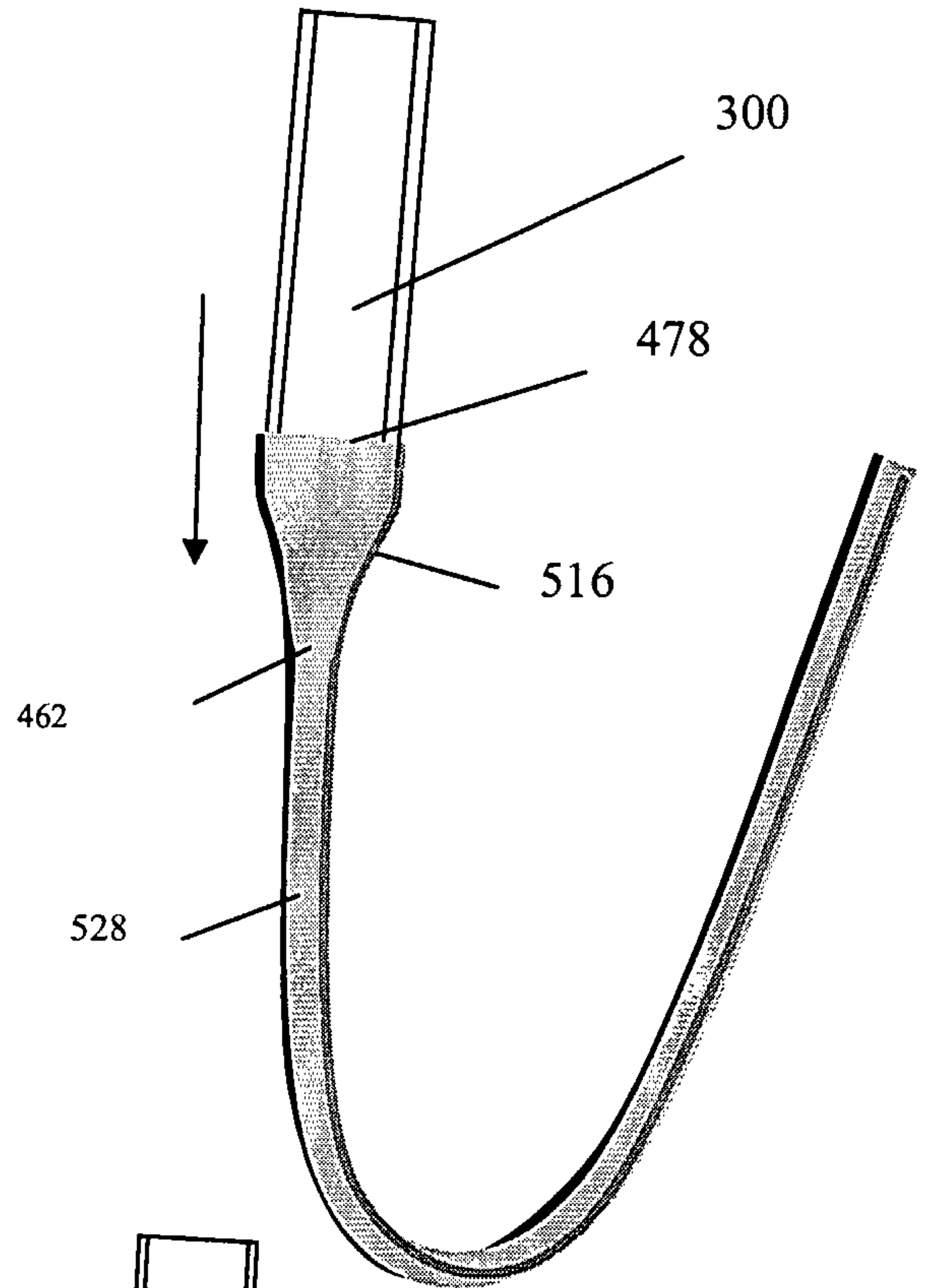

Fig. 155

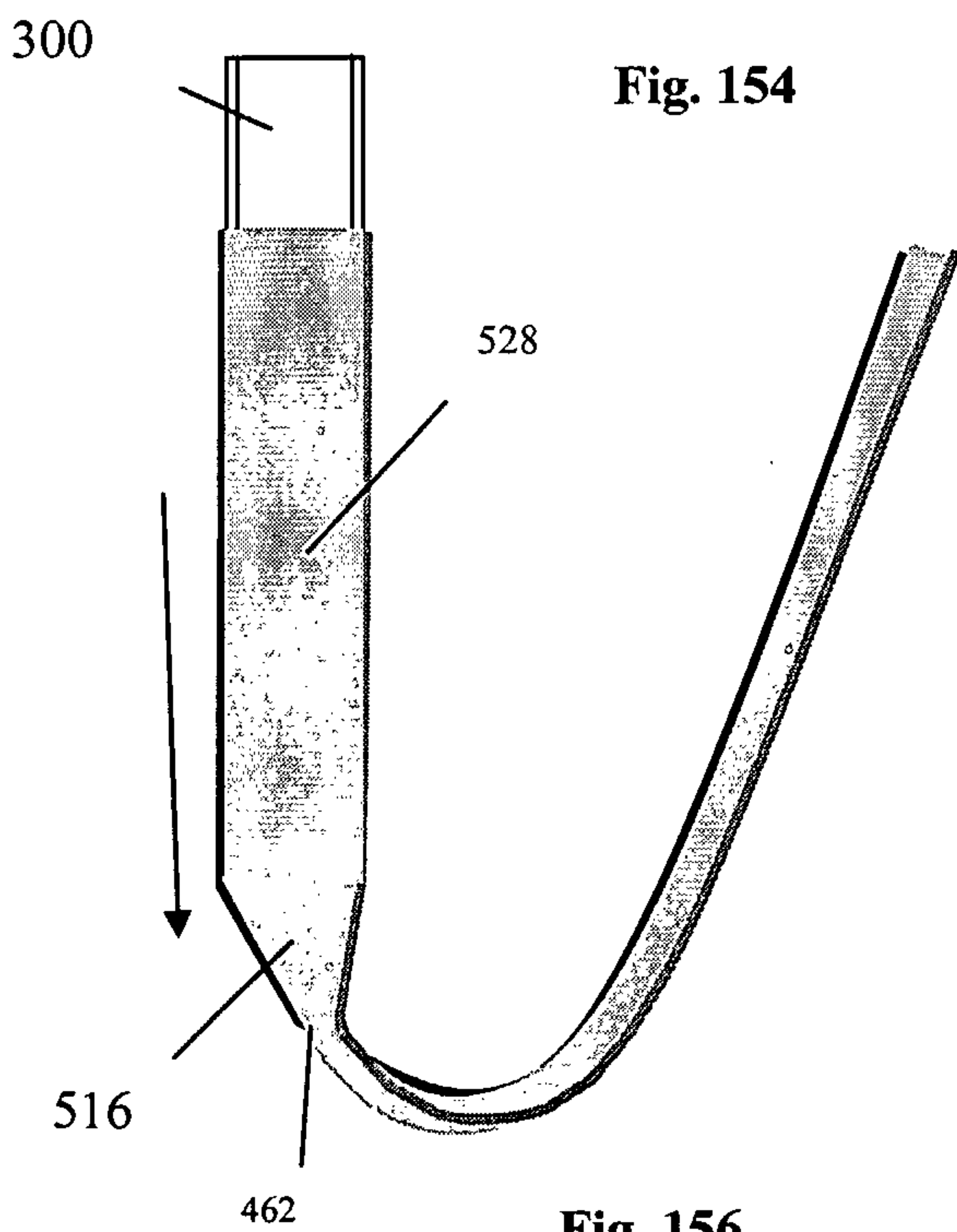

Fig. 156

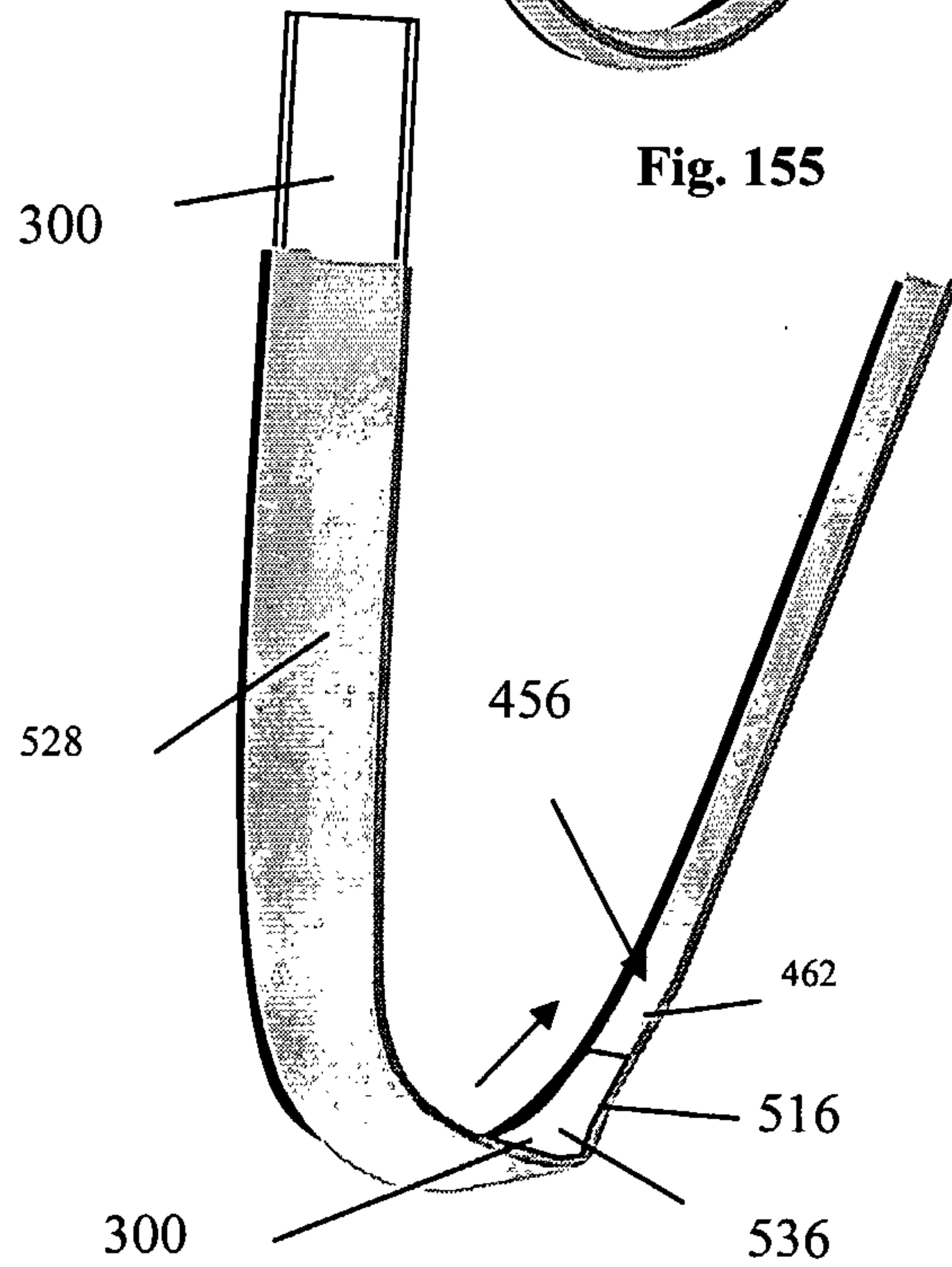

Fig. 157

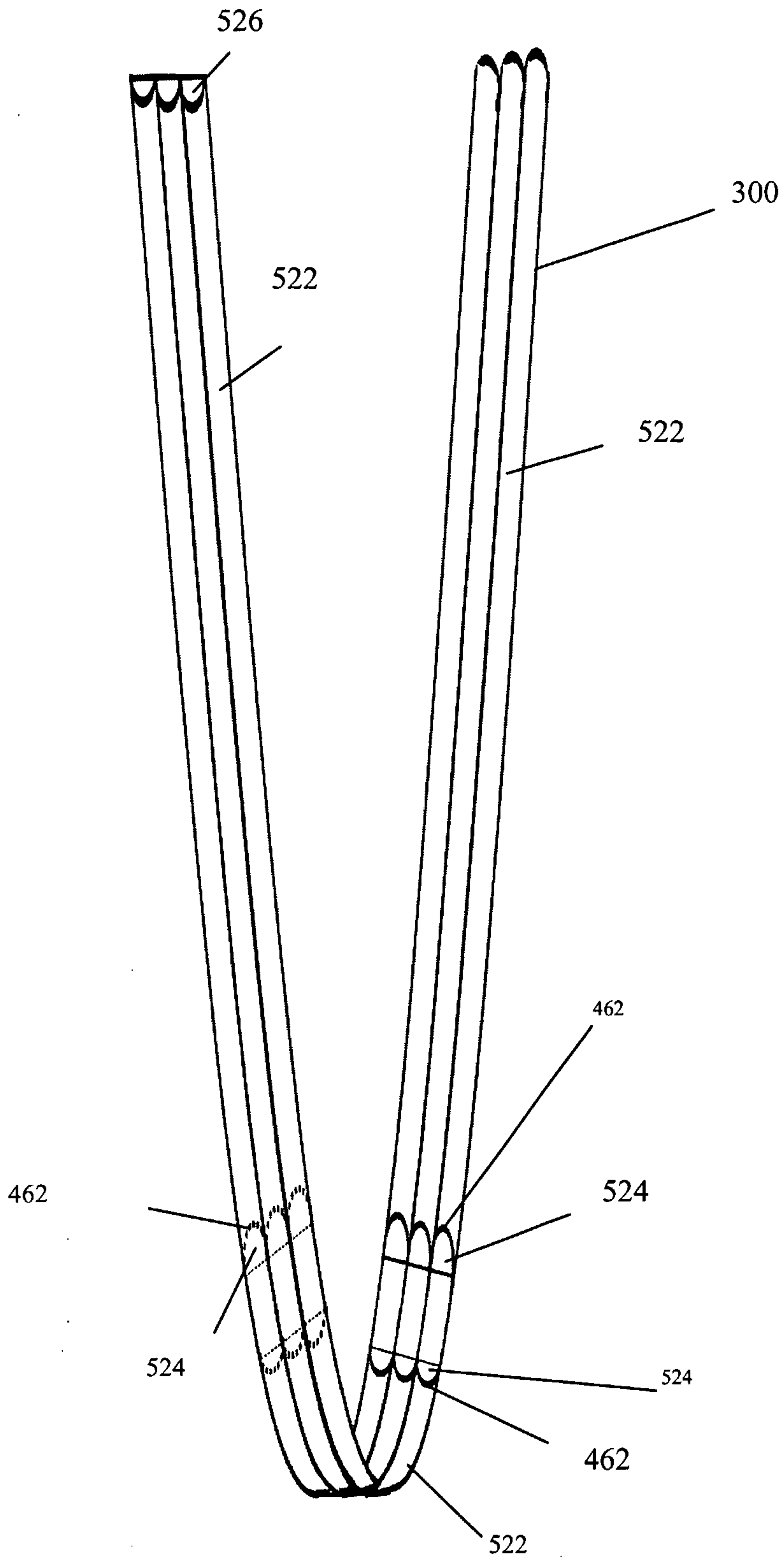

Fig. 158



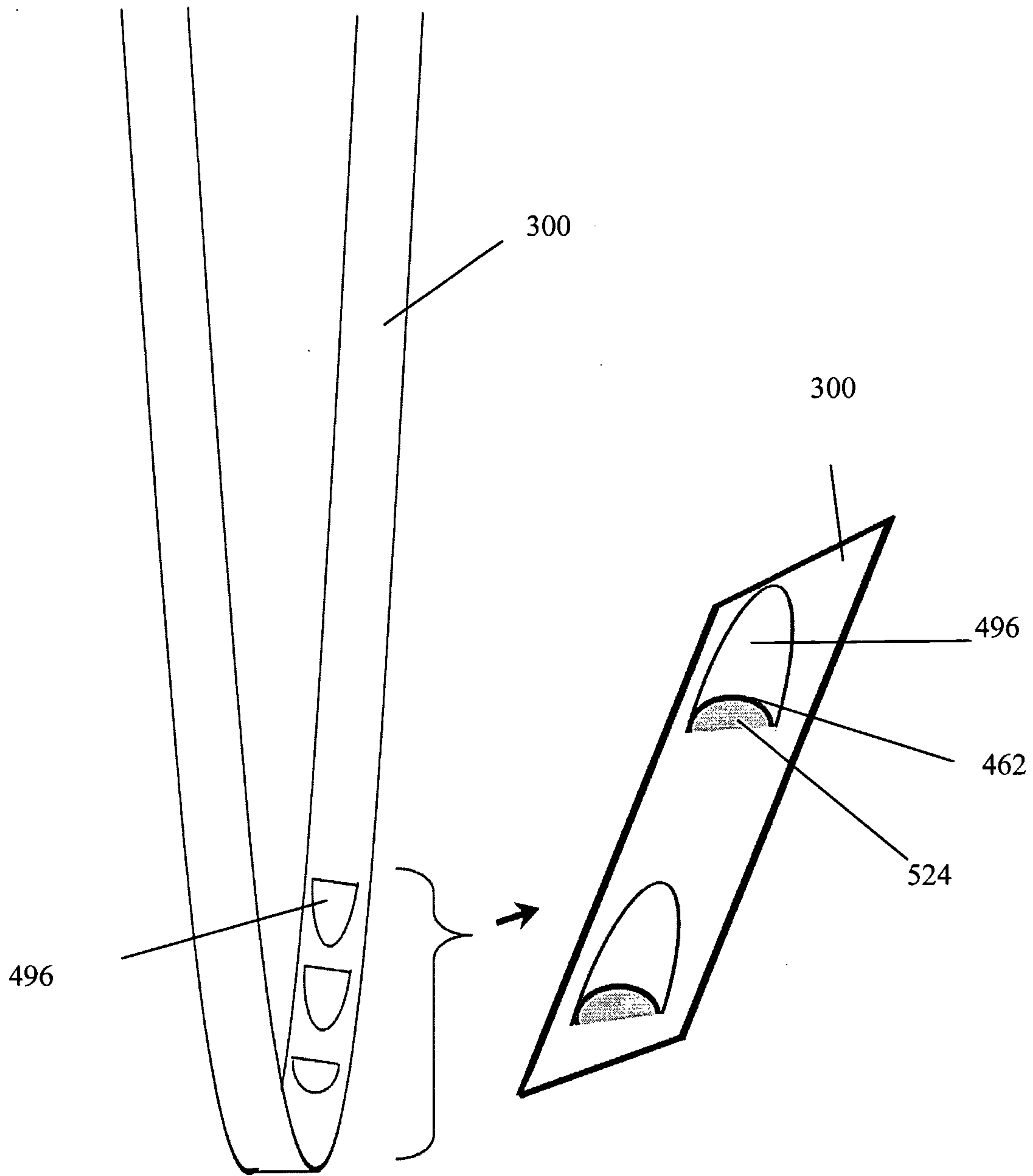

Fig. 159

Fig. 160

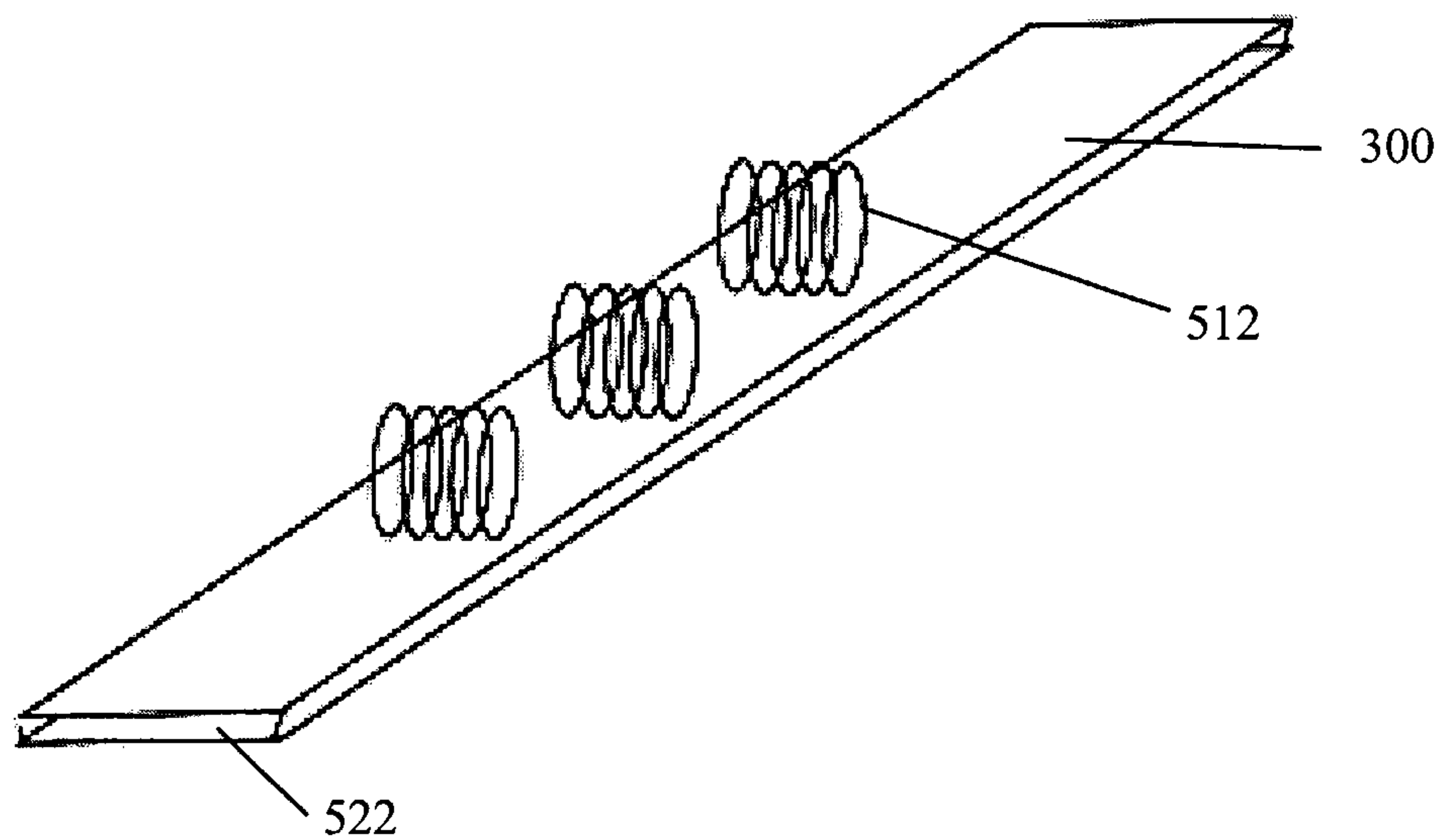

Fig. 161

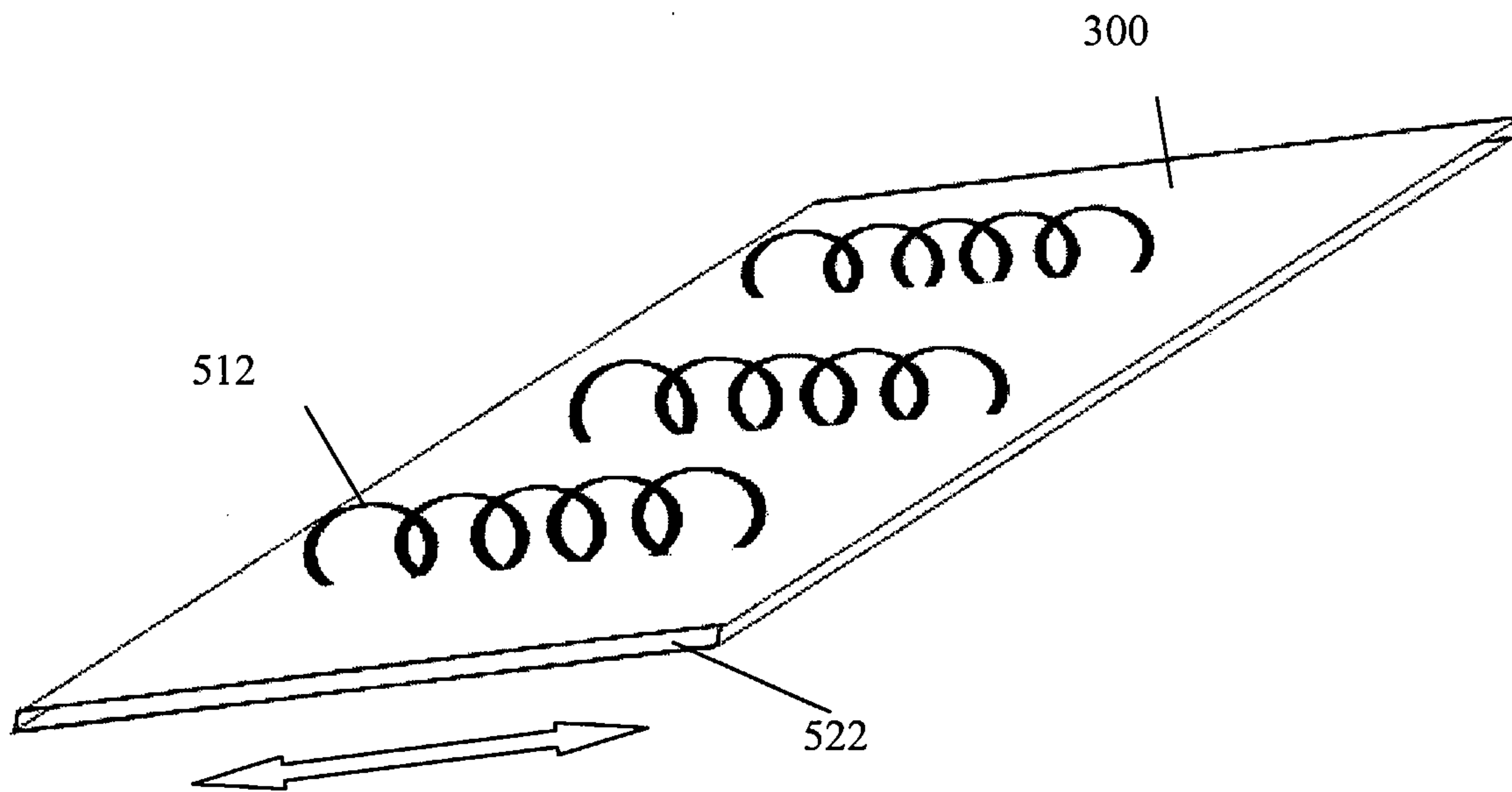
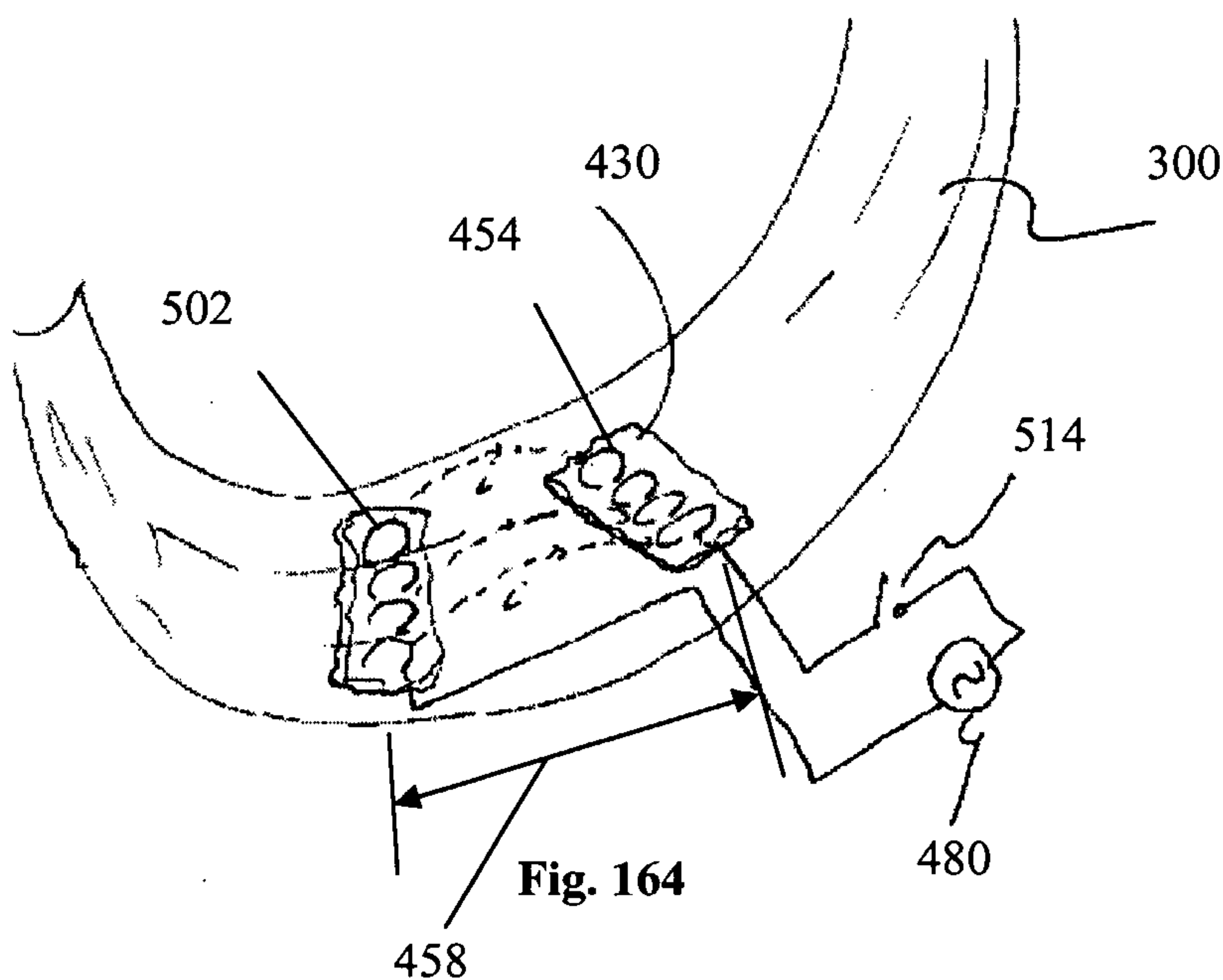
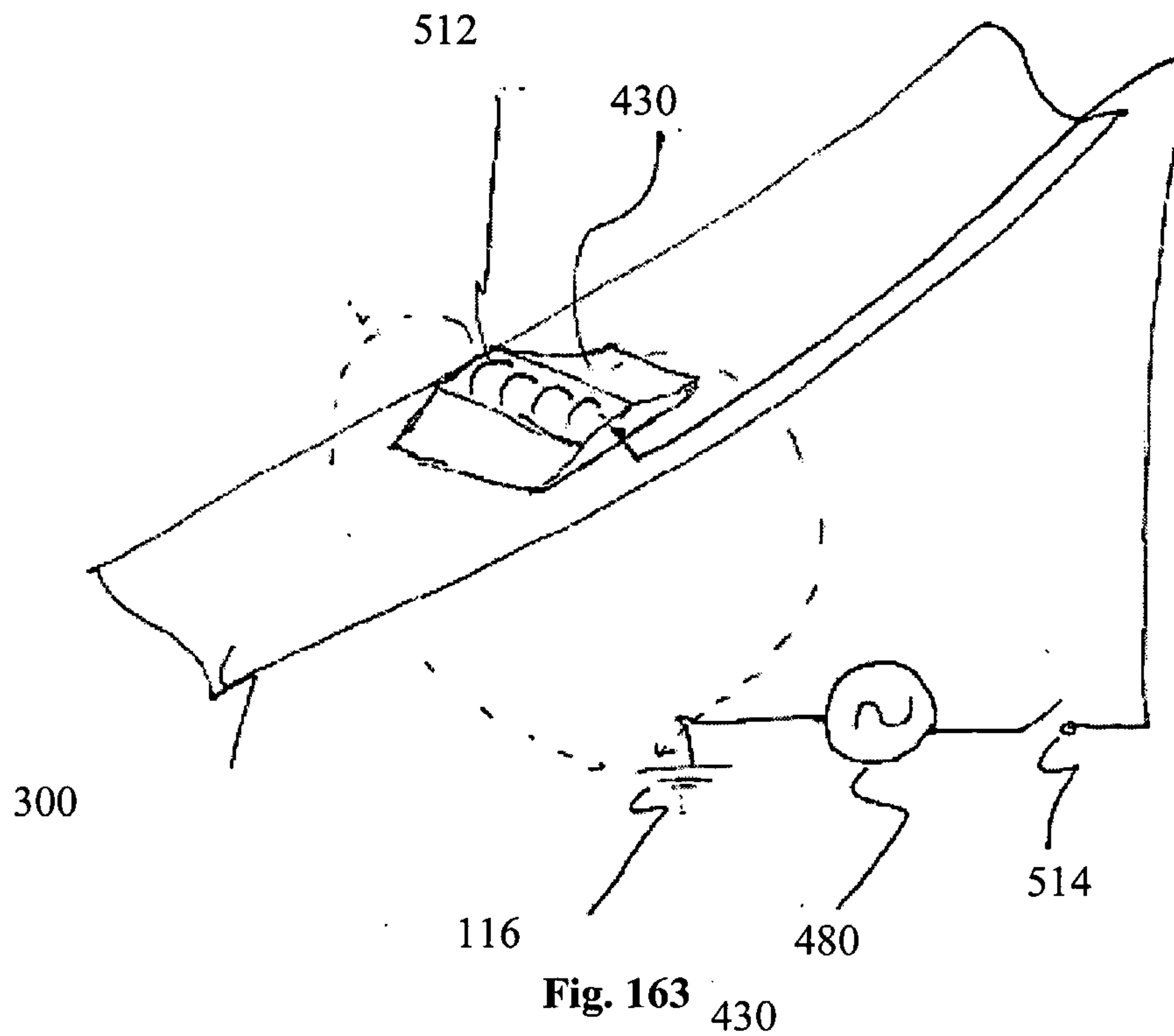

Fig. 162





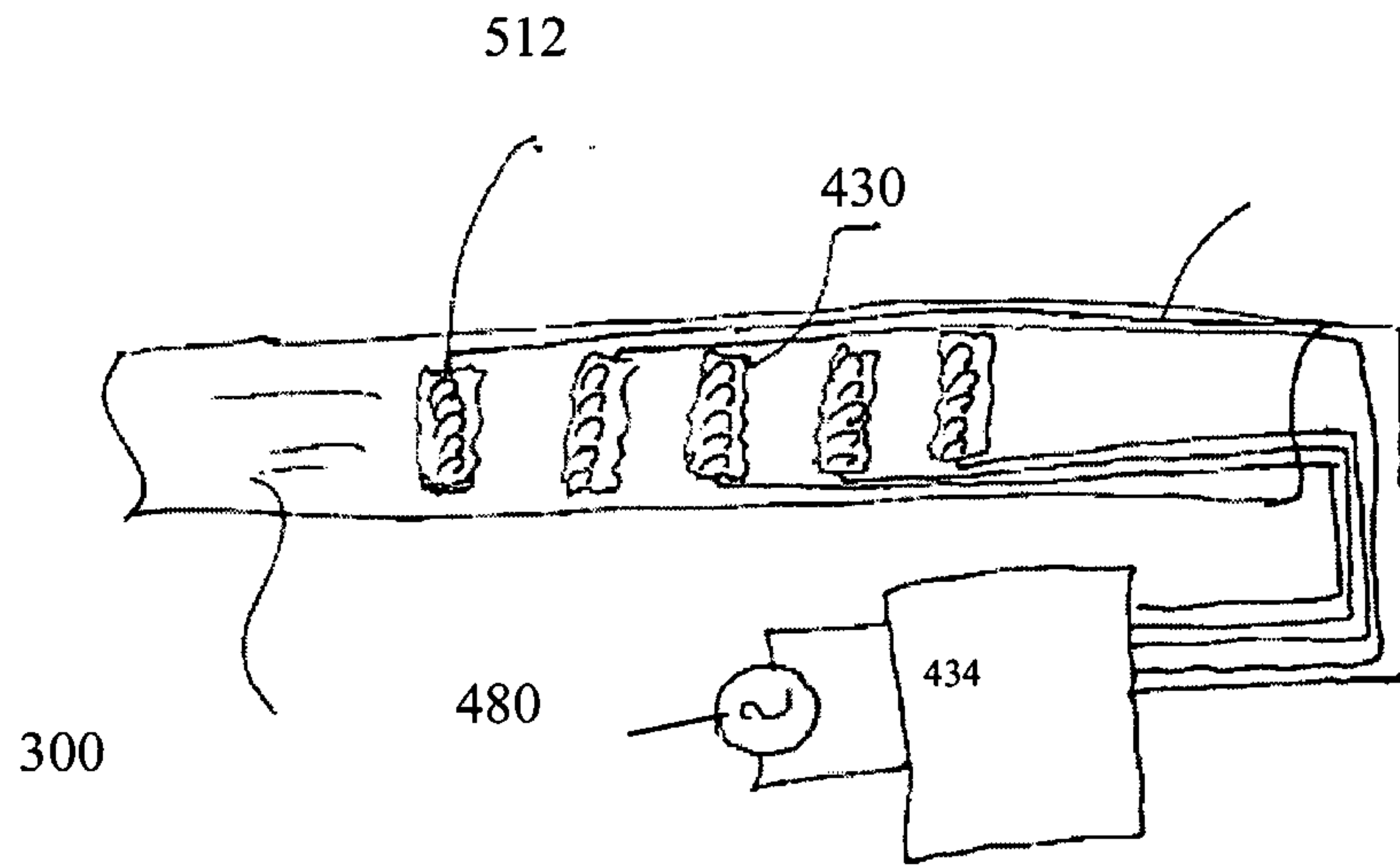

Fig. 165

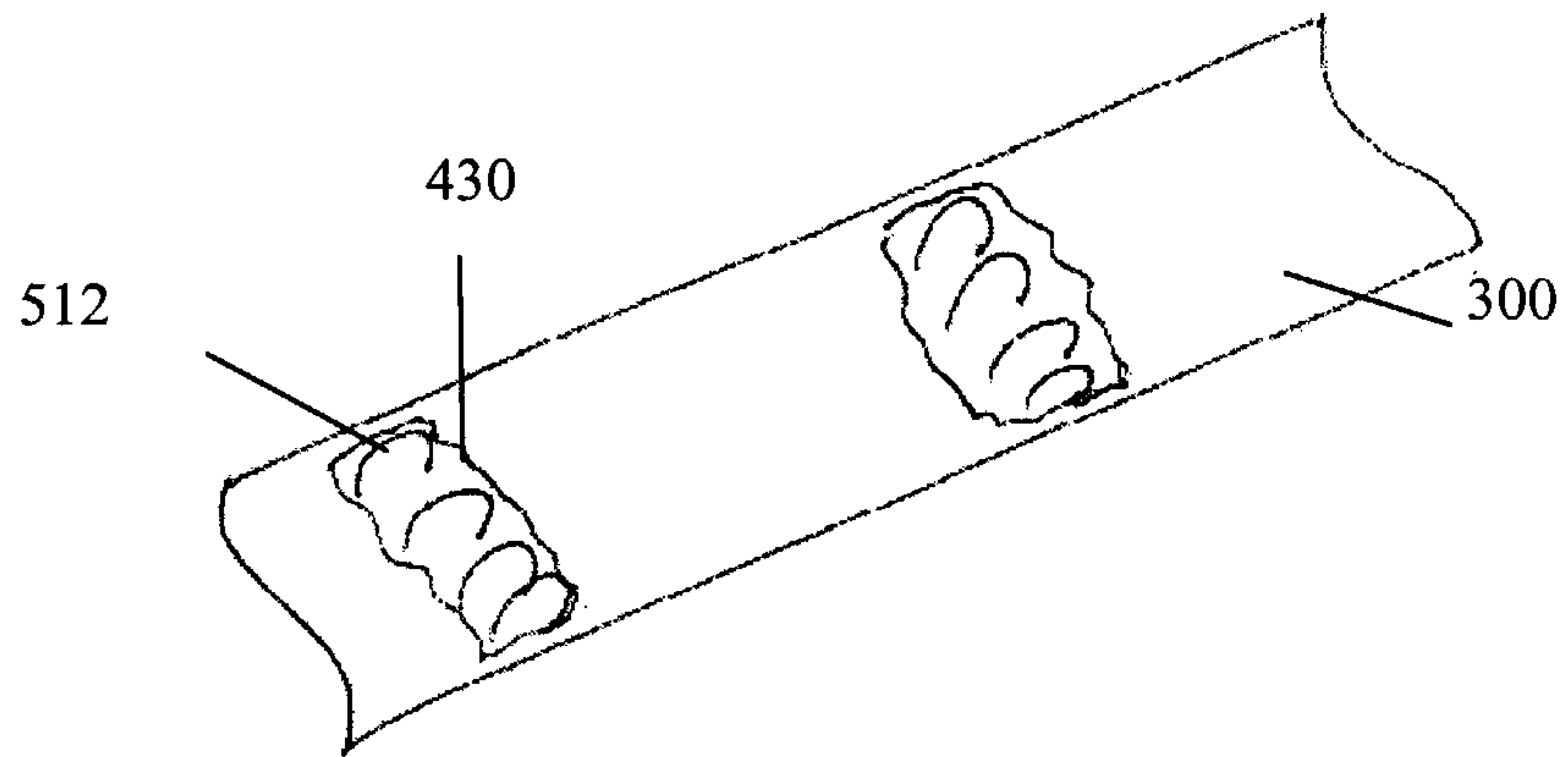

Fig. 166

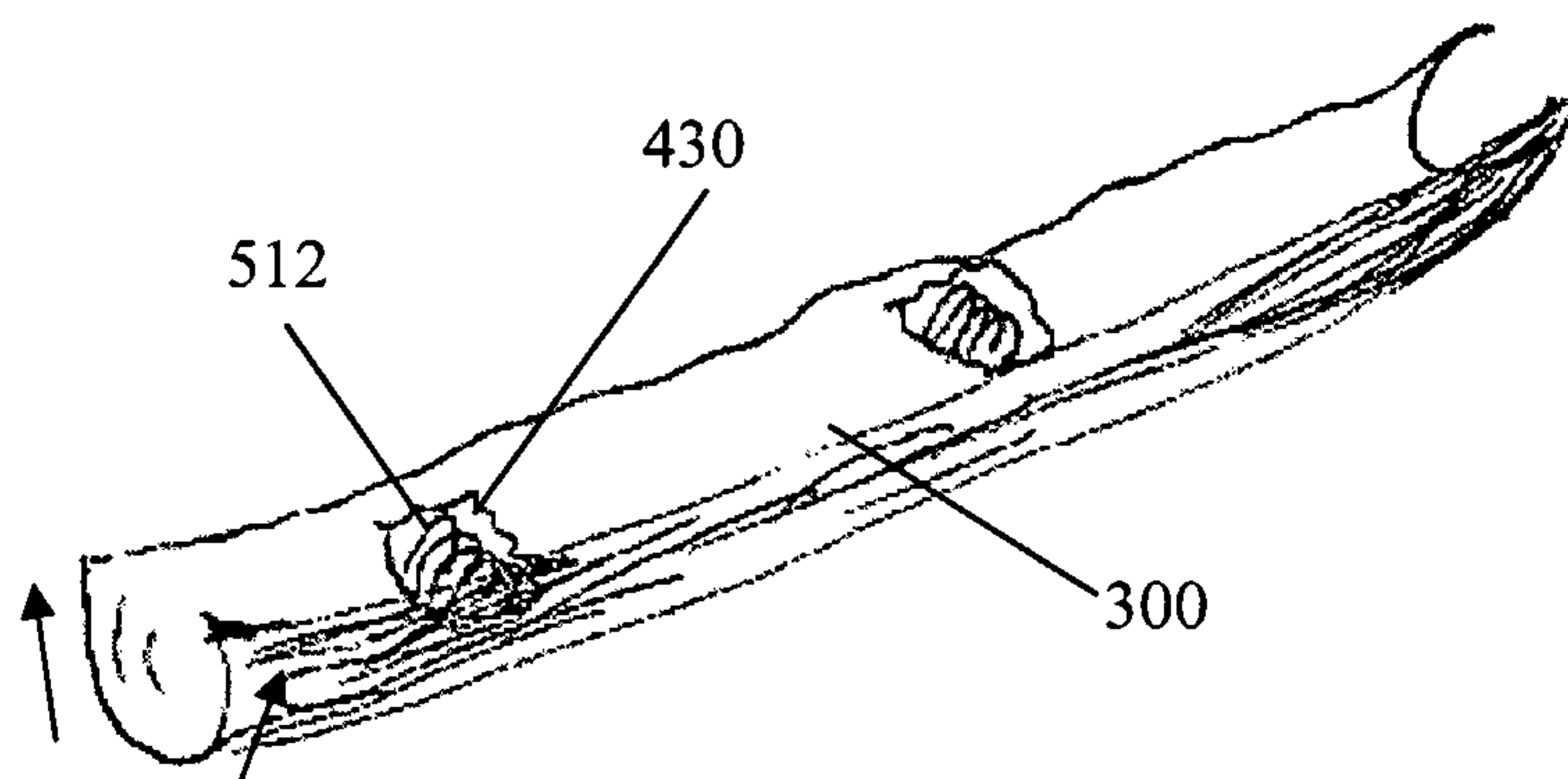
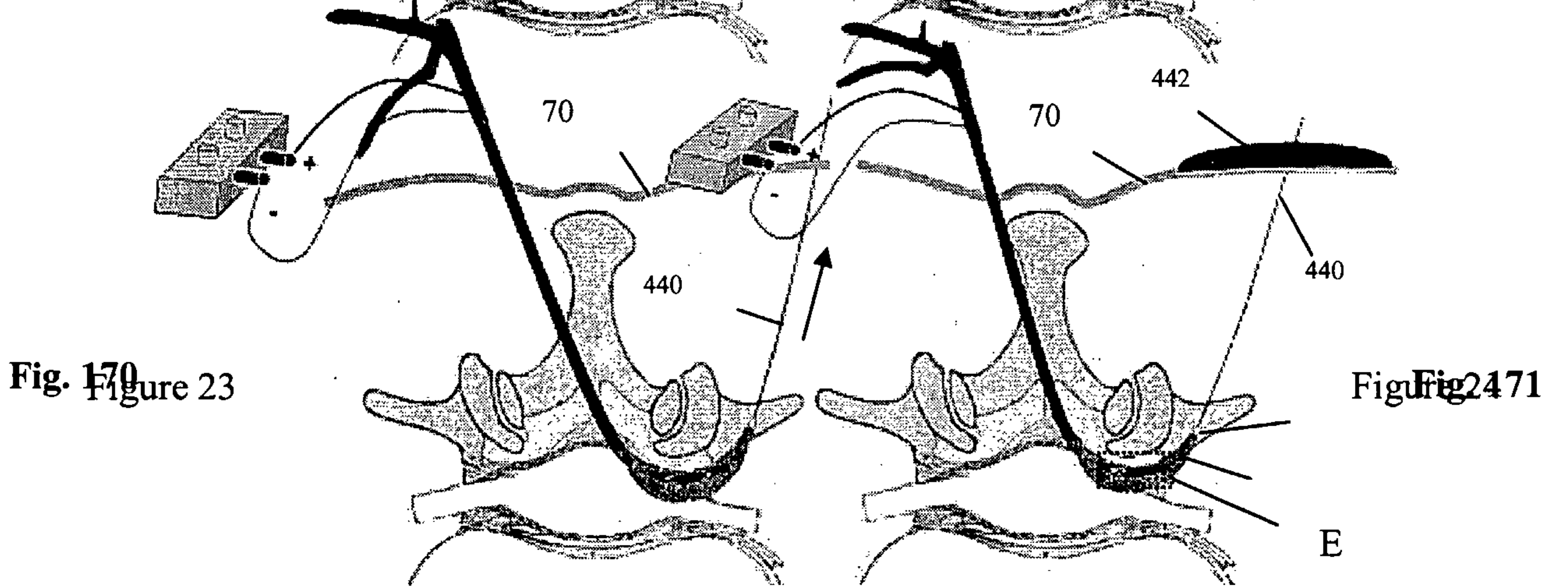
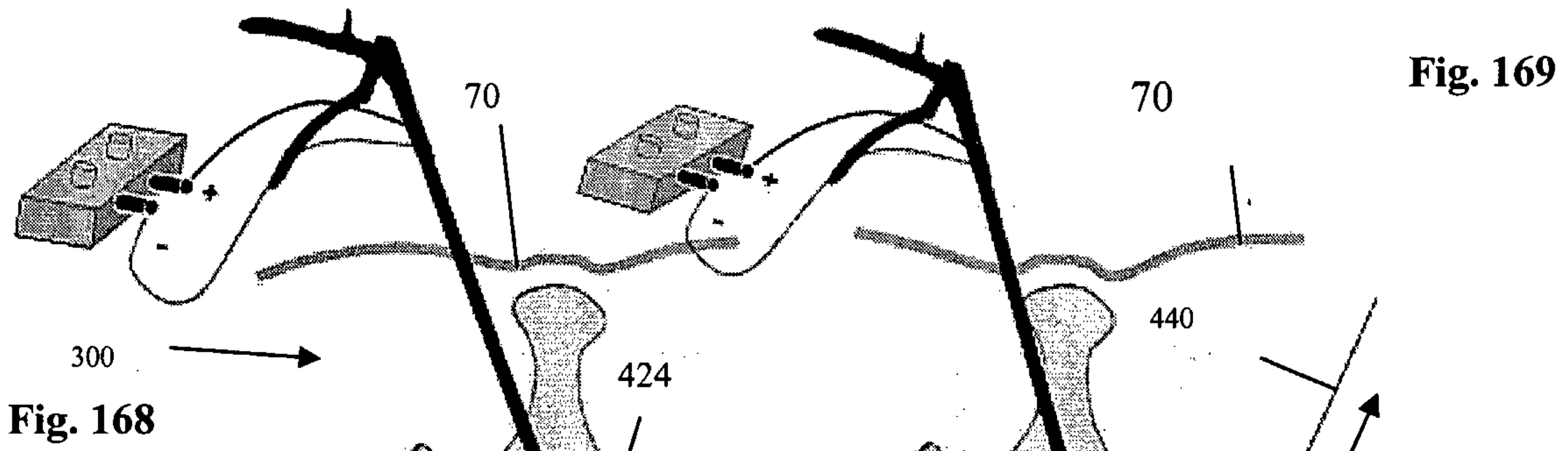

Fig. 167



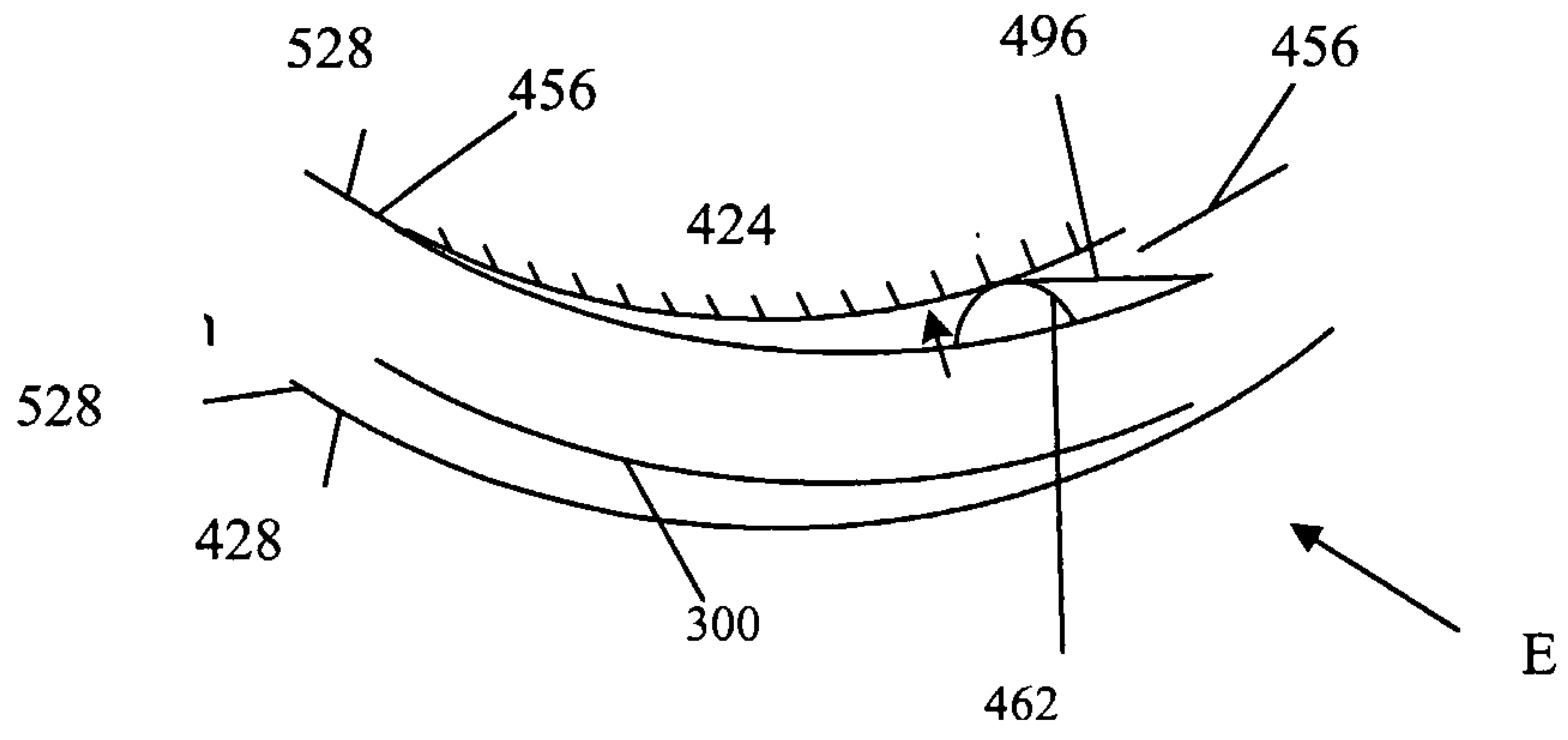

Fig. 172

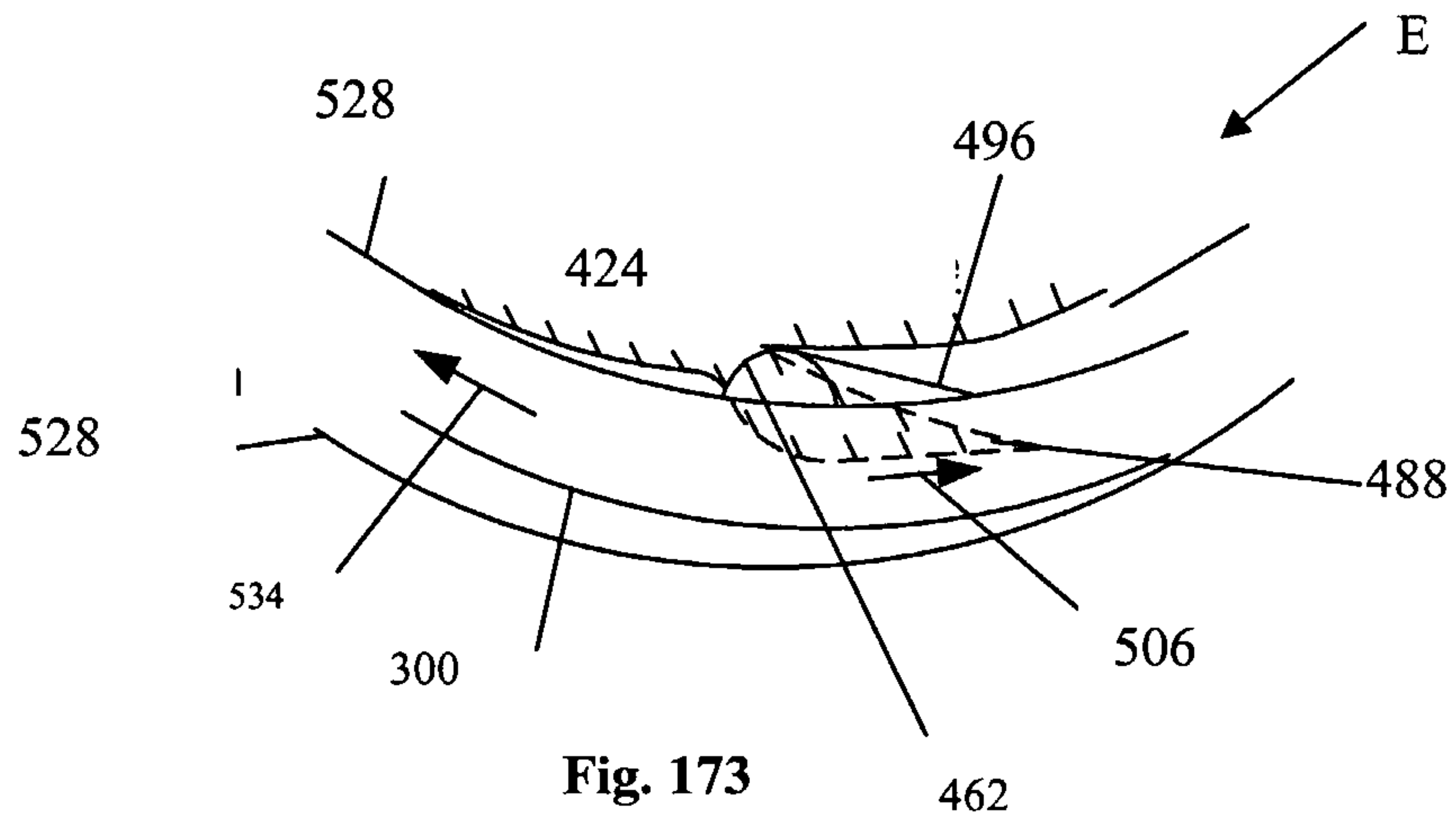

Fig. 173

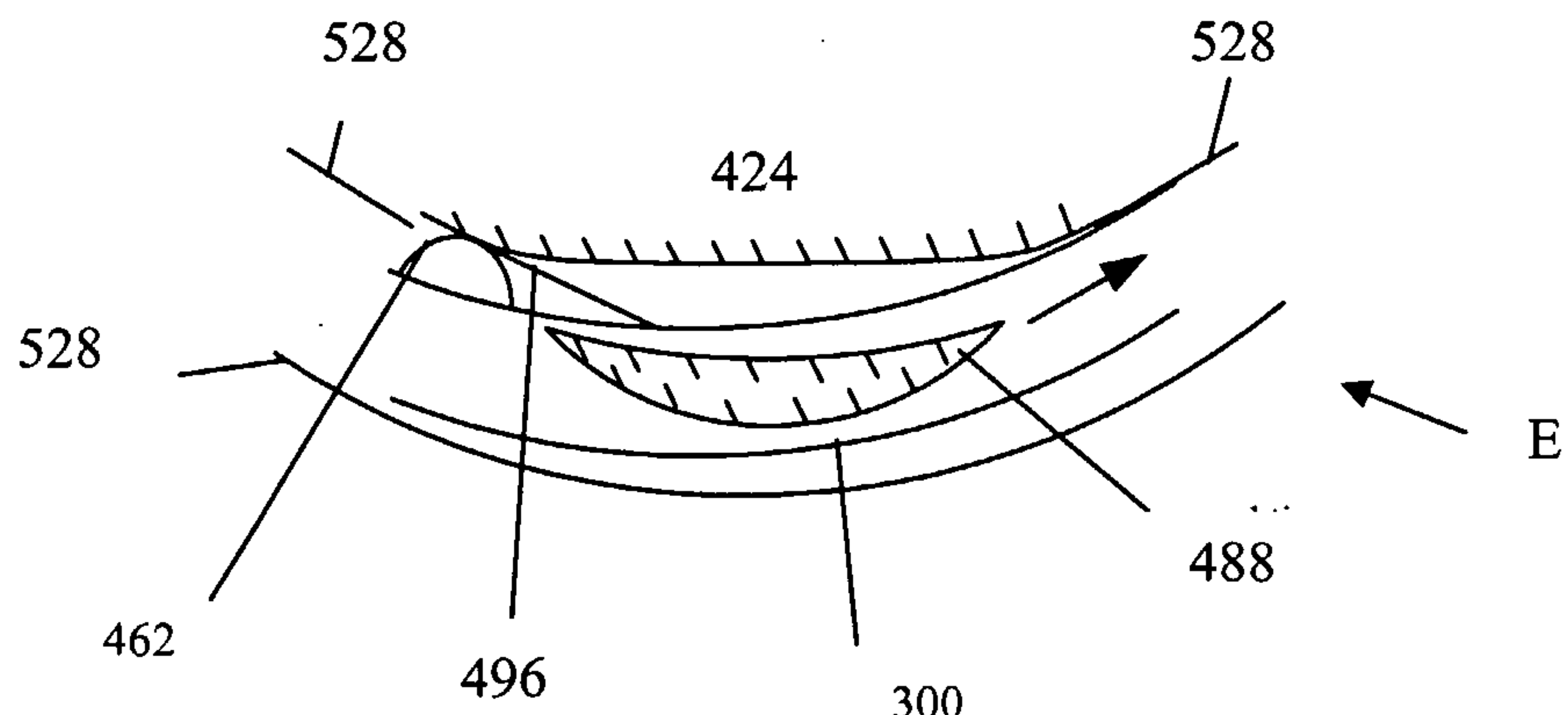

Fig. 174



