



- (51) International Patent Classification:
C07K 16/32 (2006.01)
- (21) International Application Number:
PCT/EP2010/002006
- (22) International Filing Date:
30 March 2010 (30.03.2010)
- (25) Filing Language: English
- (26) Publication Language: English
- (30) Priority Data:
09005109.5 7 April 2009 (07.04.2009) EP
- (71) Applicant (for all designated States except US): **ROCHE GLYCART AG** [CH/CH]; Wagistrasse 18, CH-8952 Schlieren (CH).
- (72) Inventors; and
- (75) Inventors/Applicants (for US only): **BOSENMAIER, Birgit** [DE/DE]; Horst-Wolfram-Geissler-Weg 10, 82229 Seefeld (DE). **BRINKMANN, Ulrich** [DE/DE]; Feichtlstrasse 12, 82362 Weilheim (DE). **KLEIN, Christian**

[DE/CH]; Chruetzacherweg 41, CH-8906 Bonstetten (CH). **NIEDERFELLNER, Gerhard** [DE/DE]; Dorfstrasse 36b, 82386 Oberhausen (DE). **SCHAEFER, Wolfgang** [DE/DE]; Tannhaeuserring 190, 68199 Mannheim (DE). **SCHANZER, Juergen Michael** [DE/DE]; Neuling 10, 83278 Traunstein (DE). **SUSTMANN, Claudio** [DE/DE]; Penzberger Strasse 3, 81373 Muenchen (DE). **UMANA, Pablo** [CR/CH]; Freiestr. 159, CH-8032 Zuerich (CH).

(74) Agent: **BURGER, Alexander**; Roche Diagnostics GmbH, Patentabteilung (TR-E), Postfach 11 52, 82372 Penzberg (DE).

(81) Designated States (unless otherwise indicated, for every kind of national protection available): AE, AG, AL, AM, AO, AT, AU, AZ, BA, BB, BG, BH, BR, BW, BY, BZ, CA, CH, CL, CN, CO, CR, CU, CZ, DE, DK, DM, DO, DZ, EC, EE, EG, ES, FI, GB, GD, GE, GH, GM, GT, HN, HR, HU, ID, IL, IN, IS, JP, KE, KG, KM, KN, KP, KR, KZ, LA, LC, LK, LR, LS, LT, LU, LY, MA, MD, ME, MG, MK, MN, MW, MX, MY, MZ, NA, NG, NI, NO, NZ, OM, PE, PG, PH, PL, PT, RO, RS, RU, SC, SD,

[Continued on next page]

(54) Title: BISPECIFIC ANTI-ERBB-2/ANTI-C-MET ANTIBODIES

Fig. 5a

(57) Abstract: The present invention relates to bispecific antibodies against human ErbB-2 and against human c-Met, methods for their production, pharmaceutical compositions containing said antibodies, and uses thereof.

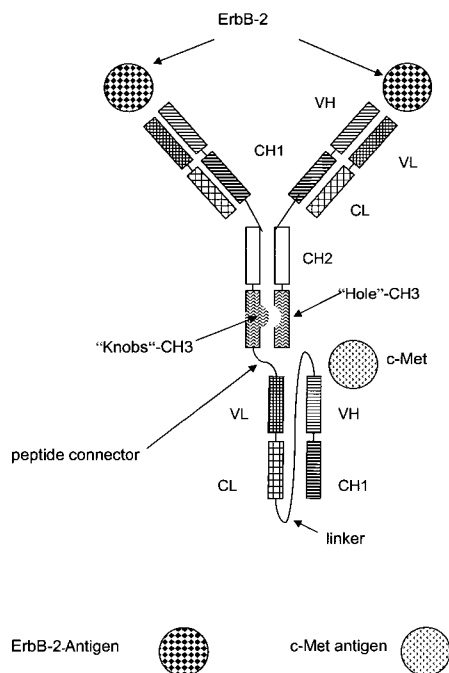

WO 2010/115553 A1



SE, SG, SK, SL, SM, ST, SV, SY, TH, TJ, TM, TN, TR, TT, TZ, UA, UG, US, UZ, VC, VN, ZA, ZM, ZW.

TR), OAPI (BF, BJ, CF, CG, CI, CM, GA, GN, GQ, GW, ML, MR, NE, SN, TD, TG).

(84) Designated States (unless otherwise indicated, for every kind of regional protection available): ARIPO (BW, GH, GM, KE, LR, LS, MW, MZ, NA, SD, SL, SZ, TZ, UG, ZM, ZW), Eurasian (AM, AZ, BY, KG, KZ, MD, RU, TJ, TM), European (AT, BE, BG, CH, CY, CZ, DE, DK, EE, ES, FI, FR, GB, GR, HR, HU, IE, IS, IT, LT, LU, LV, MC, MK, MT, NL, NO, PL, PT, RO, SE, SI, SK, SM,

Declarations under Rule 4.17:

— of inventorship (Rule 4.17(iv))

Published:

— with international search report (Art. 21(3))

— with sequence listing part of description (Rule 5.2(a))

26575 WO-WJ

Bispecific anti-ErbB-2 /anti-c-Met antibodies

The present invention relates to bispecific antibodies against human ErbB-2 and against human c-Met, methods for their production, pharmaceutical compositions containing said antibodies, and uses thereof.

Background of the Invention

5 ErbB family proteins

The ErbB protein family consists of 4 members ErbB-1, also named epidermal growth factor receptor (EGFR) ErbB-2, also named HER2 in humans and neu in rodents, ErbB-3, also named HER3 and ErbB-4, also named HER4. The ErbB family proteins are receptor tyrosine kinases and represent important mediators of
10 cell growth, differentiation and survival.

ErbB-2 and anti-ErbB-2 antibodies

The second member of the ErbB protein family, ErbB-2 (also known as ERBB2, HER2; CD340, HER-2/neu, c-erb B2/neu protein, neuroblastoma/glioblastoma derived oncogene homolog | v-erb-b2 avian erythroblastic leukemia viral oncogene
15 homolog 2; SEQ ID NO:14) is a protein that has no ligand binding domain of its own and therefore cannot bind growth factors. However, it does bind tightly to other ligand-bound EGF receptor family members to form a heterodimer, stabilizing ligand binding and enhancing kinase-mediated activation of downstream signalling pathways, such as those involving mitogen-activated protein kinase and phosphatidylinositol-3 kinase. Allelic variations at amino acid positions 654 and
20 655 of isoform a (positions 624 and 625 of isoform b) have been reported, with the most common allele, Ile654/Ile655, shown here. Amplification and/or overexpression of this gene has been reported in numerous cancers, including breast and ovarian tumors. Alternative splicing results in several additional
25 transcript variants, some encoding different isoforms and others that have not been fully characterized. ErbB-2 was originally identified as the product of the transforming gene from neuroblastomas of chemically treated rats. The activated form of the neu proto-oncogene results from a point mutation (valine to glutamic acid) in the transmembrane region of the encoded protein (Semba, K., et al., PNAS
30 82 (1985) 6497-501; Coussens, L., et al., Science 230 (1985) 1132-9; Bargmann, C.I., et al., Nature 319 (1986) 226-30; Yamamoto, T., et al., Nature 319 (1986) 230-4).

Amplification of the human homolog of neu is observed in breast and ovarian cancers and correlates with a poor prognosis (Slamon, D.J., et al., Science 235 (1987) 177-182; Slamon, D.J., et al., Science 244 (1989) 707-712; and US 4,968,603). To date, no point mutation analogous to that in the neu proto-oncogene has been reported for human tumors. Overexpression of HER2 (frequently but not uniformly due to gene amplification) has also been observed in other carcinomas including carcinomas of the stomach, endometrium, salivary gland, lung, kidney, colon, thyroid, pancreas and bladder. See, among others, King, C.R., et al., Science 229 (1985) 974-976; Yokota, J., et al., Lancet 1 (1986) 765-767; Fukushige, S., et al., Mol Cell Biol. 6 (1986) 955-958; Guerin, M., et al., Oncogene Res. 3 (1988) 21-31; Cohen, J.A., et al., Oncogene, 4 (1989) 81-88; Yonemura, Y., et al., Cancer Res. 51 (1991) 1034-1038; Borst, M.P., et al., Gynecol. Oncol. 38 (1990) 364-366; Weiner, D.B., et al., Cancer Res. 50 (1990) 421-425; Kern, J.A., et al., Cancer Res. 50 (1990) 5184-5187; Park, J.B., et al., Cancer Res. 49 (1989) 6605-6609; Zhau, H.E., et al., Mol. Carcinog. 3 (1990) 254-257; Aasland, R., et al., Br. J. Cancer 57 (1988) 358-363; Williams, T.M., et al., Pathobiology 59 (1991) 46-52; and McCann, A., et al., Cancer 65 (1990) 88-92. HER2 may be overexpressed in prostate cancer (Gu, K., et al., Cancer Lett. 99 (1996) 185-189; Ross, J.S., et al., Hum. Pathol. 28 (1997) 827-833; Ross, J.S., et al., Cancer 79 (1997) 2162-2170; and Sadasivan, R., et al., J. Urol. 150 (1993) 126-131).

Antibodies directed against the human HER2 protein products have been generated e.g. by Hudziak, R.M., et al., Mol. Cell. Biol. 9 (1989) 1165-1172 which describes the generation of a panel of anti-HER2 antibodies which were characterized using the human breast tumor cell line SK-BR-3. This panel of anti-HER2 antibodies includes, inter alia, the 2C4 (pertuzumab) and 4D5 (trastuzumab, Herceptin™) antibodies, which are directed to different epitopes of the extracellular domain of HER2. Relative cell proliferation of the SK-BR-3 cells following exposure to the antibodies was determined by crystal violet staining of the monolayers after 72 hours. Using this assay, maximum inhibition was obtained with the antibody called 4D5 (trastuzumab, Herceptin™) which inhibited cellular proliferation by 56 %. Other antibodies in the panel reduced cellular proliferation to a lesser extent in this assay. The antibody 4D5 was further found to sensitize HER2-overexpressing breast tumor cell lines to the cytotoxic effects of TNF-alpha (US 5,677,171). The HER2 antibodies discussed in Hudziak, R.M., et al. are further characterized in e.g. Fendly, B.M., et al., Cancer Research 50 (1990) 1550-1558.

c-Met and anti-c-Met antibodies

MET (mesenchymal-epithelial transition factor) is a proto-oncogene that encodes a protein MET, (also known as c-Met; hepatocyte growth factor receptor HGFR; HGF receptor; scatter factor receptor; SF receptor; SEQ ID NO:13) (Dean, M., et al., Nature 318 (1985) 385-8; Chan, A., M., et al., Oncogene 1 (1987) 229-33; Bottaro, D., P., et al., Science 251 (1991) 802-4; Naldini, L., et al., EMBO J. 10 (1991) 2867-78; Maulik, Gautam, et al., Cytokine Growth Factor Rev. 13 (2002) 41-59) MET is a membrane receptor that is essential for embryonic development and wound healing. Hepatocyte growth factor (HGF) is the only known ligand of the MET receptor. MET is normally expressed by cells of epithelial origin, while expression of HGF is restricted to cells of mesenchymal origin. Upon HGF stimulation, MET induces several biological responses that collectively give rise to a program known as invasive growth. Abnormal MET activation in cancer correlates with poor prognosis, where aberrantly active MET triggers tumor growth, formation of new blood vessels (angiogenesis) that supply the tumor with nutrients, and cancer spread to other organs (metastasis). MET is deregulated in many types of human malignancies, including cancers of kidney, liver, stomach, breast, and brain. Normally, only stem cells and progenitor cells express MET, which allows these cells to grow invasively in order to generate new tissues in an embryo or regenerate damaged tissues in an adult. However, cancer stem cells are thought to hijack the ability of normal stem cells to express MET, and thus become the cause of cancer persistence and spread to other sites in the body.

The proto-oncogene MET product is the hepatocyte growth factor receptor and encodes tyrosine-kinase activity. The primary single chain precursor protein is post-translationally cleaved to produce the alpha and beta subunits, which are disulfide linked to form the mature receptor. Various mutations in the MET gene are associated with papillary renal carcinoma.

Anti-c-Met antibodies are known e.g. from US 5,686,292, US 7,476,724, WO 2004/072117, WO 2004/108766, WO 2005/016382, WO 2005/063816, WO 2006/015371, WO 2006/104911, WO 2007/126799, or WO 2009/007427

C-Met binding peptides are known e.g. from Matzke, A., et al., Cancer Res65 (14) (2005) 6105-10. And Tam, Eric, M., et al., J. Mol. Biol. 385 (2009)79-90.

Multispecific antibodies

A wide variety of recombinant antibody formats have been developed in the recent past, e.g. tetravalent bispecific antibodies by fusion of, e.g., an IgG antibody format and single chain domains (see e.g. Coloma, M., J., et al., *Nature Biotech* 15 (1997) 159-163; WO 2001/077342; and Morrison, S., L., *Nature Biotech* 25 (2007) 1233-1234).

Also several other new formats wherein the antibody core structure (IgA, IgD, IgE, IgG or IgM) is no longer retained such as dia-, tria- or tetrabodies, minibodies, several single chain formats (scFv, Bis-scFv), which are capable of binding two or more antigens, have been developed (Holliger, P., et al., *Nature Biotech* 23 (2005) 1126-1136; Fischer, N., Léger, O., *Pathobiology* 74 (2007) 3-14; Shen, J., et al., *Journal of Immunological Methods* 318 (2007) 65-74; Wu, C., et al., *Nature Biotech.* 25 (2007) 1290-1297).

All such formats use linkers either to fuse the antibody core (IgA, IgD, IgE, IgG or IgM) to a further binding protein (e.g. scFv) or to fuse e.g. two Fab fragments or scFvs (Fischer, N., Léger, O., *Pathobiology* 74 (2007) 3-14). It has to be kept in mind that one may want to retain effector functions, such as e.g. complement-dependent cytotoxicity (CDC) or antibody dependent cellular cytotoxicity (ADCC), which are mediated through the Fc receptor binding, by maintaining a high degree of similarity to naturally occurring antibodies.

In WO 2007/024715 are reported dual variable domain immunoglobulins as engineered multivalent and multispecific binding proteins. A process for the preparation of biologically active antibody dimers is reported in US 6,897,044. Multivalent F_v antibody construct having at least four variable domains which are linked with each other via peptide linkers are reported in US 7,129,330. Dimeric and multimeric antigen binding structures are reported in US 2005/0079170. Tri- or tetra-valent monospecific antigen-binding protein comprising three or four Fab fragments bound to each other covalently by a connecting structure, which protein is not a natural immunoglobulin are reported in US 6,511,663. In WO 2006/020258 tetravalent bispecific antibodies are reported that can be efficiently expressed in prokaryotic and eukaryotic cells, and are useful in therapeutic and diagnostic methods. A method of separating or preferentially synthesizing dimers which are linked via at least one interchain disulfide linkage from dimers which are not linked via at least one interchain disulfide linkage from a mixture comprising the two types of polypeptide dimers is reported in US 2005/0163782. Bispecific tetravalent

receptors are reported in US 5,959,083. Engineered antibodies with three or more functional antigen binding sites are reported in WO 2001/077342.

5 Multispecific and multivalent antigen-binding polypeptides are reported in WO 1997/001580. WO 1992/004053 reports homoconjugates, typically prepared from monoclonal antibodies of the IgG class which bind to the same antigenic
10 determinant are covalently linked by synthetic cross-linking. Oligomeric monoclonal antibodies with high avidity for antigen are reported in WO 1991/06305 whereby the oligomers, typically of the IgG class, are secreted having two or more immunoglobulin monomers associated together to form
15 tetravalent or hexavalent IgG molecules. Sheep-derived antibodies and engineered antibody constructs are reported in US 6,350,860, which can be used to treat diseases wherein interferon gamma activity is pathogenic. In US 2005/0100543 are reported targetable constructs that are multivalent carriers of bi-specific antibodies, i.e., each molecule of a targetable construct can serve as a carrier of two or more
20 bi-specific antibodies. Genetically engineered bispecific tetravalent antibodies are reported in WO 1995/009917. In WO 2007/109254 stabilized binding molecules that consist of or comprise a stabilized scFv are reported. US 2007/0274985 relates to antibody formats comprising single chain Fab (scFab) fragments.

20 WO 2008/140493 relates to anti-EGFR family member antibodies and bispecific antibodies comprising one or more anti-EGFR family member antibodies. US 2004/0071696 relates to bispecific antibody molecules which bind to members of the EGFR protein family.

25 WO2009111707(A1) relates to a combination therapy with Met and HER antagonists. WO2009111691(A2A3) to a combination therapy with Met and EGFR antagonists.

WO2004072117 relates to c-Met antibodies which induces c-Met downregulation/internalization and their potential use in bispecific antibodies inter alia with ErbB-2 as second antigen.

Summary of the Invention

30 A first aspect of the current invention is a bispecific antibody specifically binding to human ErbB-2 and human c-Met comprising a first antigen-binding site that specifically binds to human ErbB-2 and a second antigen-binding site that specifically binds to human c-Met, characterized in that said bispecific antibody

shows an internalization of c-Met of no more than 15 % when measured after 1 hour in a flow cytometry assay on OVCAR-8 cells, as compared to internalization of c-Met in the absence of antibody.

5 In one embodiment of the invention said antibody is a bivalent or trivalent, bispecific antibody specifically binding to human ErbB-2 and to human c-Met comprising one or two antigen-binding sites that specifically bind to human ErbB-2 and one antigen-binding site that specifically binds to human c-Met.

10 In one embodiment of the invention said antibody is a trivalent, bispecific antibody specifically binding to human ErbB-2 and to human c-Met comprising two antigen-binding sites that specifically bind to human ErbB-2 and a third antigen-binding site that specifically binds to human c-Met.

15 In one embodiment of the invention said antibody is a bivalent, bispecific antibody specifically binding to human ErbB-2 and to human c-Met comprising one antigen-binding sites that specifically bind to human ErbB-2 and one antigen-binding site that specifically binds to human c-Met.

One aspect of the invention is a bispecific antibody specifically binding to human ErbB-2 and human c-Met comprising a first antigen-binding site that specifically binds to human ErbB-2 and a second antigen-binding site that specifically binds to human c-Met, characterized in that

20 said first antigen-binding site comprises in the heavy chain variable domain a CDR3H region of SEQ ID NO: 15, a CDR2H region of SEQ ID NO: 16, and a CDR1H region of SEQ ID NO:17, and in the light chain variable domain a CDR3L region of SEQ ID NO: 18, a CDR2L region of SEQ ID NO:19, and a CDR1L region of SEQ ID NO:20;
25 and
said second antigen-binding site comprises in the heavy chain variable domain a CDR3H region of SEQ ID NO: 21, a CDR2H region of, SEQ ID NO: 22, and a CDR1H region of SEQ ID NO: 23, and in the light chain variable domain a CDR3L region of SEQ ID NO: 24, a
30 CDR2L region of SEQ ID NO: 25, and a CDR1L region of SEQ ID NO: 26.

Said bispecific antibody is preferably characterized in that

said first antigen-binding site specifically binding to ErbB-2 comprises as heavy chain variable domain the sequence of SEQ ID NO: 1, and as light chain variable domain the sequence of SEQ ID NO: 2; and said second antigen-binding site specifically binding to c-Met comprises as heavy chain variable domain the sequence of SEQ ID NO: 3, and as light chain variable domain the sequence of SEQ ID NO: 4.

A further aspect of the invention is a bispecific antibody according to the invention characterized in comprising a constant region of IgG1 or IgG3 subclass

10 In one embodiment said bispecific antibody according to the invention is characterized in that said antibody is glycosylated with a sugar chain at Asn297 whereby the amount of fucose within said sugar chain is 65 % or lower.

A further aspect of the invention is a nucleic acid molecule encoding a chain of said bispecific antibody.

15 Still further aspects of the invention are a pharmaceutical composition comprising said bispecific antibody, said composition for the treatment of cancer, the use of said bispecific antibody for the manufacture of a medicament for the treatment of cancer, a method of treatment of patient suffering from cancer by administering said bispecific antibody to a patient in the need of such treatment.

20 Breast tumors often express high levels of ErbB2 and a high percentage of ErbB2 positive tumors are also c-Met positive. It was shown previously in a number of studies that c-Met expression in breast tumors correlates with poor prognosis (Kang, J., Y., et al., Cancer Res. 63 (2003) 1101-1105; Lengyel, E., et al., Int. J. Cancer 113 (2005) 678-82). Therefore the bispecific <ErbB-2-c-Met> antibodies according to the invention have valuable properties like antitumor efficacy and cancer cell inhibition.

25 The antibodies according to the invention show highly valuable properties like, e.g. inter alia, growth inhibition of cancer cells expressing both receptors ErbB2 and c-Met, antitumor efficacy causing a benefit for a patient suffering from cancer. The bispecific <ErbB2-c-Met> antibodies according to the invention show reduced internalization of the c-Met receptor when compared to their parent monospecific, bivalent <c-Met> antibodies on cancer cells expressing both receptors ErbB2 and c-Met.

Detailed Description of the Invention

5 A first aspect of the current invention is a bispecific antibody specifically binding to human ErbB-2 and human c-Met comprising a first antigen-binding site that specifically binds to human ErbB-2 and a second antigen-binding site that specifically binds to human c-Met, characterized in that said bispecific antibody shows an internalization of c-Met of no more than 15 % when measured after 1 hour in a flow cytometry assay on OVCAR-8 cells, as compared to internalization of c-Met in the absence of said bispecific antibody.

10 Thus the invention is directed to a bispecific antibody that specifically binds to human ErbB-2 and human c-Met comprising a first antigen-binding site that specifically binds to human ErbB-2 and a second antigen-binding site that specifically binds to human c-Met, wherein the bispecific antibody causes an increase in internalization of c-Met on OVCAR-8 cells of no more than 15 % when measured after 1 hour of OVCAR-8 cell-antibody incubation as measured by a flow cytometry assay, as compared to internalization of c-Met on OVCAR-8 cells in the absence of antibody.

15 In one embodiment said bispecific antibody specifically binding to human ErbB-2 and human c-Met comprising a first antigen-binding site that specifically binds to human ErbB-2 and a second antigen-binding site that specifically binds to human c-Met is characterized in that said bispecific antibody shows an internalization of c-Met of no more than 10 % when measured after 1 hour in a flow cytometry assay on OVCAR-8 cells, as compared to internalization of c-Met in the absence of said bispecific antibody.

20 In one embodiment said bispecific antibody specifically binding to human ErbB-2 and human c-Met comprising a first antigen-binding site that specifically binds to human ErbB-2 and a second antigen-binding site that specifically binds to human c-Met is characterized in that said bispecific antibody shows an internalization of c-Met of no more than 7 % when measured after 1 hour in a flow cytometry assay on OVCAR-8 cells, as compared to internalization of c-Met in the absence of said bispecific antibody.

25 In one embodiment said bispecific antibody specifically binding to human ErbB-2 and human c-Met comprising a first antigen-binding site that specifically binds to human ErbB-2 and a second antigen-binding site that specifically binds to human c-Met is characterized in that said bispecific antibody shows an internalization of c-Met of no more than 5 % when measured after 1 hour in a flow cytometry assay on OVCAR-8 cells, as compared to internalization of c-Met in the absence of said bispecific antibody.

30 In one embodiment said bispecific antibody specifically binding to human ErbB-2 and human c-Met comprising a first antigen-binding site that specifically binds to human ErbB-2 and a second antigen-binding site that specifically binds to human c-Met is characterized in that said bispecific antibody shows an internalization of c-Met of no more than 3 % when measured after 1 hour in a flow cytometry assay on OVCAR-8 cells, as compared to internalization of c-Met in the absence of said bispecific antibody.

c-Met is characterized in that said bispecific antibody shows an internalization of c-Met of no more than 5 % when measured after 1 hour in a flow cytometry assay on OVCAR-8 cells, as compared to internalization of c-Met in the absence of said bispecific antibody.

5 The term “the internalization of c-Met” refers to the antibody-induced c-Met receptor internalization on OVCAR-8 cells (NCI Cell Line designation; purchased from NCI (National Cancer Institute) OVCAR-8-NCI; Schilder, R.J., et al., *Int. J. Cancer* 45 (1990) 416-422; Ikediobi, O.N. et al., *Mol. Cancer Ther.* 5 (2006) 2606-2612; Lorenzi, P.L. et al., *Mol. Cancer Ther.* 8 (2009) 713–724) as compared to the
10 internalization of c-Met in the absence of antibody. Such internalization of the c-Met receptor is induced by the bispecific antibodies according to the invention and is measured after 1 hour in a flow cytometry assay (FACS) as described in Example 11. A bispecific antibody according the invention shows an internalization of c-Met of no more than 15 % on OVCAR-8 cells after 1 hour of
15 antibody exposure as compared to the internalization of c-Met in the absence of antibody. In one embodiment said antibody shows an internalization of c-Met of no more than 10 %. In one embodiment said antibody shows an internalization of c-Met of no more than 7 %. In one embodiment said antibody shows an internalization of c-Met of no more than 5 %.

20 Another aspect of the current invention is a bispecific antibody specifically binding to human ErbB-2 and human c-Met comprising a first antigen-binding site that specifically binds to human ErbB-2 and a second antigen-binding site that specifically binds to human c-Met, characterized in that said bispecific antibody reduces the internalization of c-Met, compared to the internalization of c-Met
25 induced by the (corresponding) monospecific, bivalent parent c-Met antibody, by 50 % or more (in one embodiment 60 % or more; in another embodiment 70 % or more, in one embodiment 80 % or more), when measured after 1 hour in a flow cytometry assay on OVCAR-8 cells. The reduction of internalization of c-Met is calculated (using the % internalization values measured after 1 hour in a flow
30 cytometry assay on OVCAR-8 cells, whereas % internalization values below 0 are set as 0% internalization, e.g. for BsAB02 (-7% internalization is set as 0% internalization) as follows: $100 \times (\% \text{ internalization of c-Met induced by monospecific, bivalent parent c-Met antibody} - \% \text{ internalization of c-Met induced by bispecific ErbB-2/cMet antibody}) / \% \text{ internalization of c-Met induced by monospecific, bivalent parent c-Met antibody}$. For example: the bispecific ErbB-
35

2/cMet antibody BsAB02 shows an internalization of c-Met of -7 % which is set as 0%, and the monospecific, bivalent parent c-Met antibody Mab 5D5 shows an internalization of c-Met of 37%. Thus the bispecific ErbB-2/cMet antibody BsAB02 shows a reduction of the internalization of c-Met of $100 \times (40-0)/40 \% = 100 \%$ (see internalization values measured after 1 hour in a flow cytometry assay on OVCAR-8 cells in Example 11).

As used herein, "antibody" refers to a binding protein that comprises antigen-binding sites. The terms "binding site" or "antigen-binding site" as used herein denotes the region(s) of an antibody molecule to which a ligand actually binds and is derived from an antibody. The term "antigen-binding site" include antibody heavy chain variable domains (VH) and/or an antibody light chain variable domains (VL), or pairs of VH/VL, and can be derived from whole antibodies or antibody fragments such as single chain Fv, a VH domain and/or a VL domain, Fab, or (Fab)₂. In one embodiment of the current invention each of the antigen-binding sites comprises an antibody heavy chain variable domain (VH) and/or an antibody light chain variable domain (VL), and preferably is formed by a pair consisting of an antibody light chain variable domain (VL) and an antibody heavy chain variable domain (VH).

Further to antibody derived antigen-binding sites also binding peptides as described e.g. in Matzke, A., et al., Cancer Res. 65 (14) (2005) 6105-10. July 15, 2005, can specifically bind to an antigen (e.g. c-Met). Thus a further aspect of the current invention is a bispecific binding molecule specifically binding to human ErbB-2 and to human c-Met comprising a antigen-binding site that specifically binds to human ErbB-2 and a binding peptide that specifically binds to human c-Met. Thus a further aspect of the current invention is a bispecific binding molecule specifically binding to human ErbB-2 and to human c-Met comprising a antigen-binding site that specifically binds to human c-Met and a binding peptide that specifically binds to human ErbB-2.

ErbB-2 (also known as ERBB2, HER2; CD340, HER-2/neu, c-erb B2/neu protein, neuroblastoma/glioblastoma derived oncogene homolog; v-erb-b2 avian erythroblastic leukemia viral oncogene homolog 2; SEQ ID NO:14) is a protein that has no ligand binding domain of its own and therefore cannot bind growth factors. However, it does bind tightly to other ligand-bound EGF receptor family members to form a heterodimer, stabilizing ligand binding and enhancing kinase-

mediated activation of downstream signalling pathways, such as those involving mitogen-activated protein kinase and phosphatidylinositol-3 kinase. Allelic variations at amino acid positions 654 and 655 of isoform a (positions 624 and 625 of isoform b) have been reported, with the most common allele, Ile654/Ile655, shown here. Amplification and/or overexpression of this gene has been reported in numerous cancers, including breast and ovarian tumors. Alternative splicing results in several additional transcript variants, some encoding different isoforms and others that have not been fully characterized. ErB-2 was originally identified as the product of the transforming gene from neuroblastomas of chemically treated rats. The activated form of the neu proto-oncogene results from a point mutation (valine to glutamic acid) in the transmembrane region of the encoded protein (Semba, K., et al., PNAS 82 (1985) 6497-501; Coussens, L., et al., Science 230 (1985) 1132-9; Bargmann, C., I., et al., Nature 319 (1986) 226-30; Yamamoto, T., et al., Nature 319 (1986) 230-4)

The antigen-binding site, and especially heavy chain variable domains (VH) and/or antibody light chain variable domains (VL), that specifically bind to human ErbB-2 can be derived a) from known anti-ErbB-2 antibodies like e.g. 2C4 (pertuzumab; pertuzumab is a recombinant humanized version of the murine anti-HER2 antibody 2C4 and is described together with the respective method of preparation in WO 01/00245 and WO 2006/007398) and 4D5 (trastuzumab (a recombinant humanized version of the murine anti-HER2 antibody 4D5, HerceptinTM; trastuzumab and its method of preparation are described in US 5,821,337) antibodies (Hudziak, R., M., et al., Mol. Cell. Biol. 9 (1989) 1165-1172; Fendly, B., M., et al., Cancer Research 50 (1990) 1550-1558) or b) from new anti-ErbB-2 antibodies obtained by de novo immunization methods using inter alia either the human ErbB-2 protein or nucleic acid or fragments thereof or by phage display.

MET (mesenchymal-epithelial transition factor) is a proto-oncogene that encodes a protein MET, (also known as c-Met; hepatocyte growth factor receptor HGFR; HGF receptor; scatter factor receptor; SF receptor; SEQ ID NO:13) (Dean, M., et al., Nature 318 (1985) 385-8; Chan, A., M., et al., Oncogene 1 (1987) 229-33; Bottaro, D., P., et al., Science 251 (1991) 802-4; Naldini, L., et al., EMBO J. 10 (1991) 2867-78; Maulik, G., et al., Cytokine Growth Factor Rev. 13 (2002) 41-59) MET is a membrane receptor that is essential for embryonic development and wound healing. Hepatocyte growth factor (HGF) is the only known ligand of the MET receptor. MET is normally expressed by cells of epithelial origin, while

expression of HGF is restricted to cells of mesenchymal origin. Upon HGF stimulation, MET induces several biological responses that collectively give rise to a program known as invasive growth. Abnormal MET activation in cancer correlates with poor prognosis, where aberrantly active MET triggers tumor growth, formation of new blood vessels (angiogenesis) that supply the tumor with nutrients, and cancer spread to other organs (metastasis). MET is deregulated in many types of human malignancies, including cancers of kidney, liver, stomach, breast, and brain. Normally, only stem cells and progenitor cells express MET, which allows these cells to grow invasively in order to generate new tissues in an embryo or regenerate damaged tissues in an adult. However, cancer stem cells are thought to hijack the ability of normal stem cells to express MET, and thus become the cause of cancer persistence and spread to other sites in the body.

The antigen-binding site, and especially heavy chain variable domains (VH) and/or antibody light chain variable domains (VL), that specifically bind to human c-Met can be derived a) from known anti-c-Met antibodies as describe e.g. in US 5,686,292, US 7,476,724, WO 2004/072117, WO 2004/108766, WO 2005/016382, WO 2005/063816, WO 2006/015371, WO 2006/104911, WO 2007/126799, or WO 2009/007427 b) from new anti-c-Met antibodies obtained e.g. by de novo immunization methods using inter alia either the human anti-c-Met protein or nucleic acid or fragments thereof or by phage display.

A further aspect of the invention is a bispecific antibody specifically binding to human ErbB-2 and to human c-Met comprising a first antigen-binding site that specifically binds to human ErbB-2 and a second antigen-binding site that specifically binds to human c-Met characterized in that

said first antigen-binding site specifically binding to ErbB-2 comprises as heavy chain variable domain the sequence of SEQ ID NO: 1, and as light chain variable domain the sequence of SEQ ID NO: 2; and said second antigen-binding site specifically binding to c-Met comprises as heavy chain variable domain the sequence of SEQ ID NO: 3, and as light chain variable domain the sequence of SEQ ID NO: 4.

Antibody specificity refers to selective recognition of the antibody for a particular epitope of an antigen. Natural antibodies, for example, are monospecific. "Bispecific antibodies" according to the invention are antibodies which have two different antigen-binding specificities. Where an antibody has more than one

specificity, the recognized epitopes may be associated with a single antigen or with more than one antigen. Antibodies of the present invention are specific for two different antigens, i.e. ErbB-2 as first antigen and c-Met as second antigen.

5 The term “monospecific” antibody as used herein denotes an antibody that has one or more binding sites each of which bind to the same epitope of the same antigen.

The term “valent” as used within the current application denotes the presence of a specified number of binding sites in an antibody molecule. As such, the terms “bivalent”, “tetravalent”, and “hexavalent” denote the presence of two binding site, four binding sites, and six binding sites, respectively, in an antibody molecule. The bispecific antibodies according to the invention are at least “bivalent” and may be “trivalent” or “multivalent” (e.g. (“tetravalent” or “hexavalent”).

15 An antigen-binding site of an antibody of the invention can contain six complementarity determining regions (CDRs) which contribute in varying degrees to the affinity of the binding site for antigen. There are three heavy chain variable domain CDRs (CDRH1, CDRH2 and CDRH3) and three light chain variable domain CDRs (CDRL1, CDRL2 and CDRL3). The extent of CDR and framework regions (FRs) is determined by comparison to a compiled database of amino acid sequences in which those regions have been defined according to variability among the sequences. Also included within the scope of the invention are functional antigen binding sites comprised of fewer CDRs (i.e., where binding specificity is determined by three, four or five CDRs). For example, less than a complete set of 6 CDRs may be sufficient for binding. In some cases, a VH or a VL domain will be sufficient.

25 In preferred embodiments, antibodies of the invention further comprise immunoglobulin constant regions of one or more immunoglobulin classes of human origin. Immunoglobulin classes include IgG, IgM, IgA, IgD, and IgE isotypes and, in the case of IgG and IgA, their subtypes. In a preferred embodiment, an antibody of the invention has a constant domain structure of an IgG type antibody, but has four antigen binding sites. This is accomplished e.g. by linking one (or two) complete antigen binding sites (e.g., a single chain Fab fragment or a single chain Fv) specifically binding to c-Met to either to N- or C-terminus heavy or light chain of a full antibody specifically binding to ErbB-2 yielding a trivalent bispecific antibody (or tetravalent bispecific antibody). Alternatively IgG like bispecific, bivalent antibodies against human ErbB-2 and

human c-Met comprising the immunoglobulin constant regions can be used as described e.g. in EP Appl. No. 07024867.9, EP Appl. No.07024864.6, EP Appl. No.07024865.3 or Ridgway, J.B., Protein Eng. 9 (1996) 617-621; WO 96/027011; Merchant, A.M., et al., Nature Biotech 16 (1998) 677-681; Atwell, S., et al., J. Mol. Biol. 270 (1997) 26-35 and EP 1870459A1.

The terms "monoclonal antibody" or "monoclonal antibody composition" as used herein refer to a preparation of antibody molecules of a single amino acid composition.

The term "chimeric antibody" refers to an antibody comprising a variable region, i.e., binding region, from one source or species and at least a portion of a constant region derived from a different source or species, usually prepared by recombinant DNA techniques. Chimeric antibodies comprising a murine variable region and a human constant region are preferred. Other preferred forms of "chimeric antibodies" encompassed by the present invention are those in which the constant region has been modified or changed from that of the original antibody to generate the properties according to the invention, especially in regard to C1q binding and/or Fc receptor (FcR) binding. Such chimeric antibodies are also referred to as "class-switched antibodies.". Chimeric antibodies are the product of expressed immunoglobulin genes comprising DNA segments encoding immunoglobulin variable regions and DNA segments encoding immunoglobulin constant regions. Methods for producing chimeric antibodies involve conventional recombinant DNA and gene transfection techniques are well known in the art. See, e.g., Morrison, S.L., et al., Proc. Natl. Acad. Sci. USA 81 (1984) 6851-6855; US 5,202,238 and US 5,204,244.

The term "humanized antibody" refers to antibodies in which the framework or "complementarity determining regions" (CDR) have been modified to comprise the CDR of an immunoglobulin of different specificity as compared to that of the parent immunoglobulin. In a preferred embodiment, a murine CDR is grafted into the framework region of a human antibody to prepare the "humanized antibody." See, e.g., Riechmann, L., et al., Nature 332 (1988) 323-327; and Neuberger, M.S., et al., Nature 314 (1985) 268-270. Particularly preferred CDRs correspond to those representing sequences recognizing the antigens noted above for chimeric antibodies. Other forms of "humanized antibodies" encompassed by the present invention are those in which the constant region has been additionally modified or changed from that of the original antibody to generate the properties according to

the invention, especially in regard to C1q binding and/or Fc receptor (FcR) binding.

5 The term "human antibody", as used herein, is intended to include antibodies having variable and constant regions derived from human germ line immunoglobulin sequences. Human antibodies are well-known in the state of the art (van Dijk, M.A., and van de Winkel, J.G., *Curr. Opin. Chem. Biol.* 5 (2001) 368-374). Human antibodies can also be produced in transgenic animals (e.g., mice) that are capable, upon immunization, of producing a full repertoire or a selection of human antibodies in the absence of endogenous immunoglobulin production. Transfer of the human germ-line immunoglobulin gene array in such germ-line mutant mice will result in the production of human antibodies upon antigen challenge (see, e.g., Jakobovits, A., et al., *Proc. Natl. Acad. Sci. USA* 90 (1993) 2551-2555; Jakobovits, A., et al., *Nature* 362 (1993) 255-258; Brueggemann, M., et al., *Year Immunol.* 7 (1993) 33-40). Human antibodies can also be produced in phage display libraries (Hoogenboom, H., R., and Winter, G., *J. Mol. Biol.* 227 (1992) 381-388; Marks, J.D., et al., *J. Mol. Biol.* 222 (1991) 581-597). The techniques of Cole, S.P.C., et al. and Boerner, P., et al. are also available for the preparation of human monoclonal antibodies (Cole, S.P.C., et al., *Monoclonal Antibodies and Cancer Therapy*, Liss, A.L. (1985) 77-96; and Boerner, P., et al., *J. Immunol.* 147 (1991) 86-95). As already mentioned for chimeric and humanized antibodies according to the invention the term "human antibody" as used herein also comprises such antibodies which are modified in the constant region to generate the properties according to the invention, especially in regard to C1q binding and/or FcR binding, e.g. by "class switching" i.e. change or mutation of Fc parts (e.g. from IgG1 to IgG4 and/or IgG1/IgG4 mutation.)

30 The term "recombinant human antibody", as used herein, is intended to include all human antibodies that are prepared, expressed, created or isolated by recombinant means, such as antibodies isolated from a host cell such as a NS0 or CHO cell or from an animal (e.g. a mouse) that is transgenic for human immunoglobulin genes or antibodies expressed using a recombinant expression vector transfected into a host cell. Such recombinant human antibodies have variable and constant regions in a rearranged form. The recombinant human antibodies according to the invention have been subjected to *in vivo* somatic hypermutation. Thus, the amino acid sequences of the VH and VL regions of the recombinant antibodies are sequences

that, while derived from and related to human germ line VH and VL sequences, may not naturally exist within the human antibody germ line repertoire in vivo.

5 The "variable domain" (variable domain of a light chain (VL), variable region of a heavy chain (VH) as used herein denotes each of the pair of light and heavy chains which is involved directly in binding the antibody to the antigen. The domains of variable human light and heavy chains have the same general structure and each domain comprises four framework (FR) regions whose sequences are widely conserved, connected by three "hypervariable regions" (or complementarity determining regions, CDRs). The framework regions adopt a β -sheet conformation and the CDRs may form loops connecting the β -sheet structure. The CDRs in each chain are held in their three-dimensional structure by the framework regions and form together with the CDRs from the other chain the antigen binding site. The antibody heavy and light chain CDR3 regions play a particularly important role in the binding specificity/affinity of the antibodies according to the invention and therefore provide a further object of the invention.

15 The terms "hypervariable region" or "antigen-binding portion of an antibody or an antigen binding site" when used herein refer to the amino acid residues of an antibody which are responsible for antigen-binding. The hypervariable region comprises amino acid residues from the "complementarity determining regions" or "CDRs". "Framework" or "FR" regions are those variable domain regions other than the hypervariable region residues as herein defined. Therefore, the light and heavy chains of an antibody comprise from N- to C-terminus the domains FR1, CDR1, FR2, CDR2, FR3, CDR3, and FR4. CDRs on each chain are separated by such framework amino acids. Especially, CDR3 of the heavy chain is the region which contributes most to antigen binding. CDR and FR regions are determined according to the standard definition of Kabat, et al., Sequences of Proteins of Immunological Interest, 5th ed., Public Health Service, National Institutes of Health, Bethesda, MD (1991).

20 As used herein, the term "binding" or "specifically binding" refers to the binding of the antibody to an epitope of the antigen (either human ErbB-2 or human c-Met) in an in vitro assay, preferably in an plasmon resonance assay (BIAcore, GE-Healthcare Uppsala, Sweden) with purified wild-type antigen. The affinity of the binding is defined by the terms k_a (rate constant for the association of the antibody from the antibody/antigen complex), k_D (dissociation constant), and K_D (k_D/k_a). Binding or specifically binding means a binding affinity (K_D) of 10^{-8} mol/l or less,

preferably 10^{-9} M to 10^{-13} mol/l. Thus, a bispecific <ErbB2-c-Met> antibody according to the invention is specifically binding to each antigen for which it is specific with a binding affinity (K_D) of 10^{-8} mol/l or less, preferably 10^{-9} M to 10^{-13} mol/l.

- 5 Binding of the antibody to the Fc γ RIII can be investigated by a BIAcore assay (GE-Healthcare Uppsala, Sweden). The affinity of the binding is defined by the terms k_a (rate constant for the association of the antibody from the antibody/antigen complex), k_D (dissociation constant), and K_D (k_D/k_a).

10 The term "epitope" includes any polypeptide determinant capable of specific binding to an antibody. In certain embodiments, epitope determinant include chemically active surface groupings of molecules such as amino acids, sugar side chains, phosphoryl, or sulfonyl, and, in certain embodiments, may have specific three dimensional structural characteristics, and or specific charge characteristics. An epitope is a region of an antigen that is bound by an antibody.

- 15 In certain embodiments, an antibody is said to specifically bind an antigen when it preferentially recognizes its target antigen in a complex mixture of proteins and/or macromolecules.

20 The term "constant region" as used within the current applications denotes the sum of the domains of an antibody other than the variable region. The constant region is not involved directly in binding of an antigen, but exhibit various effector functions. Depending on the amino acid sequence of the constant region of their heavy chains, antibodies are divided in the classes: IgA, IgD, IgE, IgG and IgM, and several of these may be further divided into subclasses, such as IgG1, IgG2, IgG3, and IgG4, IgA1 and IgA2. The heavy chain constant regions that correspond to the different classes of antibodies are called α , δ , ϵ , γ , and μ , respectively. The light chain constant regions which can be found in all five antibody classes are called κ (kappa) and λ (lambda). The constant region are preferably derived from human origin.

- 30 The term "constant region derived from human origin" as used in the current application denotes a constant heavy chain region of a human antibody of the subclass IgG1, IgG2, IgG3, or IgG4 and/or a constant light chain kappa or lambda region. Such constant regions are well known in the state of the art and e.g. described by Kabat, E.A., (see e.g. Johnson, G. and Wu, T.T., Nucleic Acids Res.

28 (2000) 214-218; Kabat, E.A., et al., Proc. Natl. Acad. Sci. USA 72 (1975) 2785-2788).

In one embodiment the bispecific antibodies according to the invention comprise a constant region of IgG1 or IgG3 subclass (preferably of IgG1 subclass), which is preferably derived from human origin. In one embodiment the bispecific antibodies according to the invention comprise a Fc part of IgG1 or IgG3 subclass (preferably of IgG1 subclass), which is preferably derived from human origin.

While antibodies of the IgG4 subclass show reduced Fc receptor (FcγRIIIa) binding, antibodies of other IgG subclasses show strong binding. However Pro238, Asp265, Asp270, Asn297 (loss of Fc carbohydrate), Pro329, Leu234, Leu235, Gly236, Gly237, Ile253, Ser254, Lys288, Thr307, Gln311, Asn434, and His435 are residues which, if altered, provide also reduced Fc receptor binding (Shields, R.L., et al., J. Biol. Chem. 276 (2001) 6591-6604; Lund, J., et al., FASEB J. 9 (1995) 115-119; Morgan, A., et al., Immunology 86 (1995) 319-324; EP 0 307 434).

In one embodiment an antibody according to the invention has a reduced FcR binding compared to an IgG1 antibody and the full length parent antibody is in regard to FcR binding of IgG4 subclass or of IgG1 or IgG2 subclass with a mutation in S228, L234, L235 and/or D265, and/ or contains the PVA236 mutation. In one embodiment the mutations in the full length parent antibody are S228P, L234A, L235A, L235E and/or PVA236. In another embodiment the mutations in the full length parent antibody are in IgG4 S228P and in IgG1 L234A and L235A.

The constant region of an antibody is directly involved in ADCC (antibody-dependent cell-mediated cytotoxicity) and CDC (complement-dependent cytotoxicity). Complement activation (CDC) is initiated by binding of complement factor C1q to the constant region of most IgG antibody subclasses. Binding of C1q to an antibody is caused by defined protein-protein interactions at the so called binding site. Such constant region binding sites are known in the state of the art and described e.g. by Lukas, T.J., et al., J. Immunol. 127 (1981) 2555-2560; Brunhouse, R., and Cebra, J.J., Mol. Immunol. 16 (1979) 907-917; Burton, D.R., et al., Nature 288 (1980) 338-344; Thommesen, J.E., et al., Mol. Immunol. 37 (2000) 995-1004; Idusogie, E.E., et al., J. Immunol. 164 (2000) 4178-4184; Hezareh, M., et al., J. Virol. 75 (2001) 12161-12168; Morgan, A., et al., Immunology 86 (1995) 319-324; and EP 0 307 434. Such constant region binding sites are, e.g.,

characterized by the amino acids L234, L235, D270, N297, E318, K320, K322, P331, and P329 (numbering according to EU index of Kabat).

5 The term “antibody-dependent cellular cytotoxicity (ADCC)” refers to lysis of human target cells by an antibody according to the invention in the presence of effector cells. ADCC is measured preferably by the treatment of a preparation of ErB-1 and c-Met expressing cells with an antibody according to the invention in the presence of effector cells such as freshly isolated PBMC or purified effector cells from buffy coats, like monocytes or natural killer (NK) cells or a permanently growing NK cell line.

10 The term “complement-dependent cytotoxicity (CDC)” denotes a process initiated by binding of complement factor C1q to the Fc part of most IgG antibody subclasses. Binding of C1q to an antibody is caused by defined protein-protein interactions at the so called binding site. Such Fc part binding sites are known in the state of the art (see above). Such Fc part binding sites are, e.g., characterized by
15 the amino acids L234, L235, D270, N297, E318, K320, K322, P331, and P329 (numbering according to EU index of Kabat). Antibodies of subclass IgG1, IgG2, and IgG3 usually show complement activation including C1q and C3 binding, whereas IgG4 does not activate the complement system and does not bind C1q and/or C3.

20 Cell-mediated effector functions of monoclonal antibodies can be enhanced by engineering their oligosaccharide component as described in Umana, P., et al., Nature Biotechnol. 17 (1999) 176-180, and US 6,602,684. IgG1 type antibodies, the most commonly used therapeutic antibodies, are glycoproteins that have a conserved N-linked glycosylation site at Asn297 in each CH2 domain. The two
25 complex biantennary oligosaccharides attached to Asn297 are buried between the CH2 domains, forming extensive contacts with the polypeptide backbone, and their presence is essential for the antibody to mediate effector functions such as antibody dependent cellular cytotoxicity (ADCC) (Lifely, M.R., et al., Glycobiology 5 (1995) 813-822; Jefferis, R., et al., Immunol. Rev. 163 (1998) 59-76; Wright, A., and Morrison, S., L., Trends Biotechnol. 15 (1997) 26-32). Umana, P., et al. Nature
30 Biotechnol. 17 (1999) 176-180 and WO 99/54342 showed that overexpression in Chinese hamster ovary (CHO) cells of $\beta(1,4)$ -N-acetylglucosaminyltransferase III (“GnTIII”), a glycosyltransferase catalyzing the formation of bisected oligosaccharides, significantly increases the in vitro ADCC activity of antibodies.
35 Alterations in the composition of the Asn297 carbohydrate or its elimination affect

also binding to FcγR and C1q (Umana, P., et al., *Nature Biotechnol.* 17 (1999) 176-180; Davies, J., et al., *Biotechnol. Bioeng.* 74 (2001) 288-294; Mimura, Y., et al., *J. Biol. Chem.* 276 (2001) 45539-45547; Radaev, S., et al., *J. Biol. Chem.* 276 (2001) 16478-16483; Shields, R., L., et al., *J. Biol. Chem.* 276 (2001) 6591-6604; Shields, R., L., et al., *J. Biol. Chem.* 277 (2002) 26733-26740; Simmons, L.C., et al., *J. Immunol. Methods* 263 (2002) 133-147).

Methods to enhance cell-mediated effector functions of monoclonal antibodies by reducing the amount of fucose are described e.g. in WO 2005/018572, WO 2006/116260, WO 2006/114700, WO 2004/065540, WO 2005/011735, WO 2005/027966, WO 1997/028267, US 2006/0134709, US 2005/0054048, US 2005/0152894, WO 2003/035835, WO 2000/061739, Niwa, R., et al., *J. Immunol. Methods* 306 (2005) 151-160; Shinkawa, T. et al, *J Biol Chem*, 278 (2003) 3466-3473; WO 03/055993 or US 2005/0249722.

In one embodiment of the invention, the bispecific antibody according to the invention is glycosylated (IgG1 or IgG3 subclass) with a sugar chain at Asn297 whereby the amount of fucose within said sugar chain is 65 % or lower (Numbering according to Kabat). In another embodiment is the amount of fucose within said sugar chain is between 5 % and 65 %, preferably between 20 % and 40 %. "Asn297" according to the invention means amino acid asparagine located at about position 297 in the Fc region. Based on minor sequence variations of antibodies, Asn297 can also be located some amino acids (usually not more than ± 3 amino acids) upstream or downstream of position 297, i.e. between position 294 and 300.

Glycosylation of human IgG1 or IgG3 occurs at Asn297 as core fucosylated biantennary complex oligosaccharide glycosylation terminated with up to two Gal residues. Human constant heavy chain regions of the IgG1 or IgG3 subclass are reported in detail by Kabat, E.A., et al., *Sequences of Proteins of Immunological Interest*, 5th Ed. Public Health Service, National Institutes of Health, Bethesda, MD. (1991), and by Brueggemann, M., et al., *J. Exp. Med.* 166 (1987) 1351-1361; Love, T.W., et al., *Methods Enzymol.* 178 (1989) 515-527. These structures are designated as G0, G1 (α -1,6- or α -1,3-), or G2 glycan residues, depending from the amount of terminal Gal residues (Raju, T.S., *Bioprocess Int.* 1 (2003) 44-53). CHO type glycosylation of antibody Fc parts is e.g. described by Routier, F.H., *Glycoconjugate J.* 14 (1997) 201-207. Antibodies which are recombinantly expressed in non-glycomodified CHO host cells usually are fucosylated at Asn297

in an amount of at least 85 %. The modified oligosaccharides of the full length parent antibody may be hybrid or complex. Preferably the bisected, reduced/not-fucosylated oligosaccharides are hybrid. In another embodiment, the bisected, reduced/not-fucosylated oligosaccharides are complex.

5 According to the invention "amount of fucose" means the amount of said sugar within the sugar chain at Asn297, related to the sum of all glycostructures attached to Asn297 (e.g. complex, hybrid and high mannose structures) measured by MALDI-TOF mass spectrometry and calculated as average value. The relative amount of fucose is the percentage of fucose-containing structures related to all
10 glycostructures identified in an N-Glycosidase F treated sample (e.g. complex, hybrid and oligo- and high-mannose structures, resp.) by MALDI-TOF. (see e.g. WO 2008/077546(A1)).

One embodiment is a method of preparation of the bispecific antibody of IgG1 or IgG3 subclass which is glycosylated (of) with a sugar chain at Asn297 whereby the
15 amount of fucose within said sugar chain is 65 % or lower, using the procedure described in WO 2005/044859, WO 2004/065540, WO2007/031875, Umana, P., et al., Nature Biotechnol. 17 (1999) 176-180, WO 99/154342, WO 2005/018572, WO 2006/116260, WO 2006/114700, WO 2005/011735, WO 2005/027966, WO 97/028267, US 2006/0134709, US 2005/0054048, US 2005/0152894,
20 WO 2003/035835 or WO 2000/061739.

One embodiment is a method of preparation of the bispecific antibody of IgG1 or IgG3 subclass which is glycosylated (of) with a sugar chain at Asn297 whereby the amount of fucose within said sugar chain is 65 % or lower, using the procedure described in Niwa, R., et al., J. Immunol. Methods 306 (2005) 151-160; Shinkawa, T. et al, J Biol Chem, 278 (2003) 3466-3473; WO 03/055993 or US 2005/0249722.
25

Bispecific antibody Formats

Antibodies of the present invention have two or more binding sites and are multispecific and preferably bispecific. That is, the antibodies may be bispecific even in cases where there are more than two binding sites (i.e. that the antibody is
30 trivalent or multivalent). Bispecific antibodies of the invention include, for example, multivalent single chain antibodies, diabodies and triabodies, as well as antibodies having the constant domain structure of full length antibodies to which further antigen-binding sites (e.g., single chain Fv, a VH domain and/or a VL domain, Fab, or (Fab)₂,) are linked via one or more peptide-linkers. The antibodies

can be full length from a single species, or be chimerized or humanized. For an antibody with more than two antigen binding sites, some binding sites may be identical, so long as the protein has binding sites for two different antigens. That is, whereas a first binding site is specific for a ErbB-2, a second binding site is specific for c-Met, and vice versa.

In a preferred embodiment the bispecific antibody specifically binding to human ErbB-2 and to human c-Met according to the invention comprises the Fc region of an antibody (preferably of IgG1 or IgG3 subclass).

Bivalent bispecific Formats

Bispecific, bivalent antibodies against human ErbB-2 and human c-Met comprising the immunoglobulin constant regions can be used as described e.g. in WO2009/080251, WO2009/080252, WO2009/080253 or Ridgway, J.B., Protein Eng. 9 (1996) 617-621; WO 96/027011; Merchant, A.M., et al., Nature Biotech 16 (1998) 677-681; Atwell, S., et al., J. Mol. Biol. 270 (1997) 26-35 and EP 1870459A1.

Thus in one embodiment of the invention the bispecific <ErbB-2-c-Met> antibody according to the invention is a bivalent, bispecific antibody, comprising:

- a) the light chain and heavy chain of a full length antibody specifically binding to ErbB-2,; and
- b) the light chain and heavy chain of a full length antibody specifically binding to human c-Met, wherein the constant domains CL and CH1, and/or the variable domains VL and VH are replaced by each other.

In another embodiment of the invention the bispecific <ErbB-2-c-Met> antibody according to the invention is a bivalent, bispecific antibody, comprising:

- a) the light chain and heavy chain of a full length antibody specifically binding to human c-Met; and
- b) the light chain and heavy chain of a full length antibody specifically binding to ErbB-2, , wherein the constant domains CL and CH1, and/or the variable domains VL and VH are replaced by each other.

For an exemplary schematic structure with the “knob-into-holes” technology as described below see Fig 2a-c.

To improve the yields of such heterodimeric bivalent, bispecific anti-ErbB-2/anti-c-Met antibodies, the CH3 domains of said full length antibody can be altered by the “knob-into-holes” technology which is described in detail with several examples in e.g. WO 96/027011, Ridgway, J., B., et al., Protein Eng 9 (1996) 617-621; and Merchant, A.M., et al., Nat Biotechnol 16 (1998) 677-681. In this method the interaction surfaces of the two CH3 domains are altered to increase the heterodimerisation of both heavy chains containing these two CH3 domains. Each of the two CH3 domains (of the two heavy chains) can be the “knob”, while the other is the “hole”. The introduction of a disulfide bridge stabilizes the heterodimers (Merchant, A. M., et al., Nature Biotech 16 (1998) 677-681; Atwell, S., et al., J. Mol. Biol. 270 (1997) 26-35) and increases the yield.

Thus in one aspect of the invention said bivalent, bispecific antibody is further characterized in that

the CH3 domain of one heavy chain and the CH3 domain of the other heavy chain each meet at an interface which comprises an original interface between the antibody CH3 domains;

wherein said interface is altered to promote the formation of the bivalent, bispecific antibody, wherein the alteration is characterized in that:

a) the CH3 domain of one heavy chain is altered,

so that within the original interface the CH3 domain of one heavy chain that meets the original interface of the CH3 domain of the other heavy chain within the bivalent, bispecific antibody,

an amino acid residue is replaced with an amino acid residue having a larger side chain volume, thereby generating a protuberance within the interface of the CH3 domain of one heavy chain which is positionable in a cavity within the interface of the CH3 domain of the other heavy chain

and

b) the CH3 domain of the other heavy chain is altered,

so that within the original interface of the second CH3 domain that meets the original interface of the first CH3 domain within the bivalent, bispecific antibody

an amino acid residue is replaced with an amino acid residue having a smaller side chain volume, thereby generating a cavity within the interface of the second CH3 domain within which a protuberance within the interface of the first CH3 domain is positionable.

Preferably said amino acid residue having a larger side chain volume is selected from the group consisting of arginine (R), phenylalanine (F), tyrosine (Y), tryptophan (W).

Preferably said amino acid residue having a smaller side chain volume is selected from the group consisting of alanine (A), serine (S), threonine (T), valine (V).

In one aspect of the invention both CH3 domains are further altered by the introduction of cysteine (C) as amino acid in the corresponding positions of each CH3 domain such that a disulfide bridge between both CH3 domains can be formed.

In a preferred embodiment, said bivalent, bispecific comprises a T366W mutation in the CH3 domain of the "knobs chain" and T366S, L368A, Y407V mutations in the CH3 domain of the "hole chain". An additional interchain disulfide bridge between the CH3 domains can also be used (Merchant, A.M, et al., Nature Biotech 16 (1998) 677-681) e.g. by introducing a Y349C mutation into the CH3 domain of the "knobs chain" and a E356C mutation or a S354C mutation into the CH3 domain of the "hole chain". Thus in a another preferred embodiment, said bivalent, bispecific antibody comprises Y349C, T366W mutations in one of the two CH3 domains and E356C, T366S, L368A, Y407V mutations in the other of the two CH3 domains or said bivalent, bispecific antibody comprises Y349C, T366W mutations in one of the two CH3 domains and S354C, T366S, L368A, Y407V mutations in the other of the two CH3 domains (the additional Y349C mutation in one CH3 domain and the additional E356C or S354C mutation in the other CH3 domain forming a interchain disulfide bridge) (numbering always according to EU index of Kabat). But also other knobs-in-holes technologies as described by EP 1870459A1, can be used alternatively or additionally. A preferred example for said bivalent, bispecific antibody are R409D; K370E mutations in the CH3 domain of the "knobs

chain” and D399K; E357K mutations in the CH3 domain of the “hole chain” (numbering always according to EU index of Kabat).

In another preferred embodiment said bivalent, bispecific antibody comprises a T366W mutation in the CH3 domain of the “knobs chain” and T366S, L368A, Y407V mutations in the CH3 domain of the “hole chain” and additionally R409D; K370E mutations in the CH3 domain of the “knobs chain” and D399K; E357K mutations in the CH3 domain of the “hole chain”.

In another preferred embodiment said bivalent, bispecific antibody comprises Y349C, T366W mutations in one of the two CH3 domains and S354C, T366S, L368A, Y407V mutations in the other of the two CH3 domains or said bivalent, bispecific antibody comprises Y349C, T366W mutations in one of the two CH3 domains and S354C, T366S, L368A, Y407V mutations in the other of the two CH3 domains and additionally R409D; K370E mutations in the CH3 domain of the “knobs chain” and D399K; E357K mutations in the CH3 domain of the “hole chain”.

Trivalent bispecific Formats

Another preferred aspect of the current invention is a trivalent, bispecific antibody comprising

- a) a full length antibody specifically binding to human ErbB-2 and consisting of two antibody heavy chains and two antibody light chains; and
- b) one single chain Fab fragment specifically binding to human c-Met,

wherein said single chain Fab fragment under b) is fused to said full length antibody under a) via a peptide connector at the C- or N- terminus of the heavy or light chain of said full length antibody.

For an exemplary schematic structure with the “knob-into-holes” technology as described below see Fig 5a.

Another preferred aspect of the current invention is a trivalent, bispecific antibody comprising

- a) a full length antibody specifically binding to human ErbB-2 and consisting of two antibody heavy chains and two antibody light chains; and

b) one single chain Fv fragment specifically binding to human c-Met,

wherein said single chain Fv fragment under b) is fused to said full length antibody under a) via a peptide connector at the C- or N- terminus of the heavy or light chain of said full length antibody.

5 For an exemplary schematic structure with the “knob-into-holes” technology as described below see Fig 5b.

In one preferred embodiment said single chain Fab or Fv fragments binding human c-Met are fused to said full length antibody via a peptide connector at the C-terminus of the heavy chains of said full length antibody.

10 Another preferred aspect of the current invention is a trivalent, bispecific antibody comprising

a) a full length antibody specifically binding to human ErbB-2 and consisting of two antibody heavy chains and two antibody light chains;

b) a polypeptide consisting of

15 ba) an antibody heavy chain variable domain (VH); or

bb) an antibody heavy chain variable domain (VH) and an antibody constant domain 1 (CH1),

wherein said polypeptide is fused with the N-terminus of the VH domain via a peptide connector to the C-terminus of one of the two heavy chains of said full length antibody

20

c) a polypeptide consisting of

ca) an antibody light chain variable domain (VL), or

cb) an antibody light chain variable domain (VL) and an antibody light chain constant domain (CL);

25 wherein said polypeptide is fused with the N-terminus of the VL domain via a peptide connector to the C-terminus of the other of the two heavy chains of said full length antibody;

30 and wherein the antibody heavy chain variable domain (VH) of the polypeptide under b) and the antibody light chain variable domain (VL) of the polypeptide under c) together form an antigen-binding site specifically binding to human c-Met.

Preferably said peptide connectors under b) and c) are identical and are a peptide of at least 25 amino acids, preferably between 30 and 50 amino acids.

For exemplary schematic structures see Fig 3a-c.

Optionally the antibody heavy chain variable domain (VH) of the polypeptide under b) and the antibody light chain variable domain (VL) of the polypeptide under c) are linked and stabilized via a interchain disulfide bridge by introduction of a disulfide bond between the following positions:

- i) heavy chain variable domain position 44 to light chain variable domain position 100,
- 10 ii) heavy chain variable domain position 105 to light chain variable domain position 43, or
- iii) heavy chain variable domain position 101 to light chain variable domain position 100 (numbering always according to EU index of Kabat).

Techniques to introduce unnatural disulfide bridges for stabilization are described e.g. in WO 94/029350, Rajagopal, et al., Prot. Engin. (1997) 1453-59; Kobayashi, H., et al., Nuclear Medicine & Biology 25 (1998) 387-393; or Schmidt, M., et al., Oncogene 18 (1999) 1711-1721. In one embodiment the optional disulfide bond between the variable domains of the polypeptides under b) and c) is between heavy chain variable domain position 44 and light chain variable domain position 100. In one embodiment the optional disulfide bond between the variable domains of the polypeptides under b) and c) is between heavy chain variable domain position 105 and light chain variable domain position 43. (numbering always according to EU index of Kabat) In one embodiment a trivalent, bispecific antibody without said optional disulfide stabilization between the variable domains VH and VL of the single chain Fab fragments is preferred.

By the fusion of a single chain Fab, Fv fragment to one of the heavy chains (Fig 5a or 5b) or by the fusion of the different polypeptides to both heavy chains of the full lengths antibody (Fig 3a -c) a heterodimeric, trivalent bispecific antibody results. To improve the yields of such heterodimeric trivalent, bispecific anti-ErbB-2/anti-c-Met antibodies, the CH3 domains of said full length antibody can be altered by the "knob-into-holes" technology which is described in detail with several examples in e.g. WO 96/027011, Ridgway, J.B., et al., Protein Eng 9 (1996) 617-621; and Merchant, A.M., et al., Nat Biotechnol 16 (1998) 677-681. In this method the interaction surfaces of the two CH3 domains are altered to increase the

heterodimerisation of both heavy chains containing these two CH3 domains. Each of the two CH3 domains (of the two heavy chains) can be the “knob”, while the other is the “hole”. The introduction of a disulfide bridge stabilizes the heterodimers (Merchant, A.M., et al., Nature Biotech 16 (1998) 677-681; Atwell, S., et al. J. Mol. Biol. 270 (1997) 26-35) and increases the yield.

Thus in one aspect of the invention said trivalent, bispecific antibody is further characterized in that

the CH3 domain of one heavy chain of the full length antibody and the CH3 domain of the other heavy chain of the full length antibody each meet at an interface which comprises an original interface between the antibody CH3 domains;

wherein said interface is altered to promote the formation of the bivalent, bispecific antibody, wherein the alteration is characterized in that:

a) the CH3 domain of one heavy chain is altered,

so that within the original interface the CH3 domain of one heavy chain that meets the original interface of the CH3 domain of the other heavy chain within the bivalent, bispecific antibody,

an amino acid residue is replaced with an amino acid residue having a larger side chain volume, thereby generating a protuberance within the interface of the CH3 domain of one heavy chain which is positionable in a cavity within the interface of the CH3 domain of the other heavy chain

and

b) the CH3 domain of the other heavy chain is altered,

so that within the original interface of the second CH3 domain that meets the original interface of the first CH3 domain within the trivalent, bispecific antibody

an amino acid residue is replaced with an amino acid residue having a smaller side chain volume, thereby generating a cavity within the interface of the second CH3 domain within which a protuberance within the interface of the first CH3 domain is positionable.

Preferably said amino acid residue having a larger side chain volume is selected from the group consisting of arginine (R), phenylalanine (F), tyrosine (Y), tryptophan (W).

5 Preferably said amino acid residue having a smaller side chain volume is selected from the group consisting of alanine (A), serine (S), threonine (T), valine (V).

In one aspect of the invention both CH3 domains are further altered by the introduction of cysteine (C) as amino acid in the corresponding positions of each CH3 domain such that a disulfide bridge between both CH3 domains can be formed.

10 In a preferred embodiment, said trivalent, bispecific comprises a T366W mutation in the CH3 domain of the “knobs chain” and T366S, L368A, Y407V mutations in the CH3 domain of the “hole chain”. An additional interchain disulfide bridge between the CH3 domains can also be used (Merchant, A.M., et al., Nature Biotech 16 (1998) 677-681) e.g. by introducing a Y349C mutation into the CH3 domain of
15 the “knobs chain” and a E356C mutation or a S354C mutation into the CH3 domain of the “hole chain”. Thus in a another preferred embodiment, said trivalent, bispecific antibody comprises Y349C, T366W mutations in one of the two CH3 domains and E356C, T366S, L368A, Y407V mutations in the other of the two CH3 domains or said trivalent, bispecific antibody comprises Y349C, T366W mutations
20 in one of the two CH3 domains and S354C, T366S, L368A, Y407V mutations in the other of the two CH3 domains (the additional Y349C mutation in one CH3 domain and the additional E356C or S354C mutation in the other CH3 domain forming a interchain disulfide bridge) (numbering always according to EU index of Kabat). But also other knobs-in-holes technologies as described by EP 1870459A1,
25 can be used alternatively or additionally. A preferred example for said trivalent, bispecific antibody are R409D; K370E mutations in the CH3 domain of the “knobs chain” and D399K; E357K mutations in the CH3 domain of the “hole chain” (numbering always according to EU index of Kabat).

30 In another preferred embodiment said trivalent, bispecific antibody comprises a T366W mutation in the CH3 domain of the “knobs chain” and T366S, L368A, Y407V mutations in the CH3 domain of the “hole chain” and additionally R409D; K370E mutations in the CH3 domain of the “knobs chain” and D399K; E357K mutations in the CH3 domain of the “hole chain”.

- 30 -

In another preferred embodiment said trivalent, bispecific antibody comprises Y349C, T366W mutations in one of the two CH3 domains and S354C, T366S, L368A, Y407V mutations in the other of the two CH3 domains or said trivalent, bispecific antibody comprises Y349C, T366W mutations in one of the two CH3 domains and S354C, T366S, L368A, Y407V mutations in the other of the two CH3 domains and additionally R409D; K370E mutations in the CH3 domain of the “knobs chain” and D399K; E357K mutations in the CH3 domain of the “hole chain”.

Another embodiment of the current invention is a trivalent, bispecific antibody comprising

- a) a full length antibody specifically binding to human ErbB-2 and consisting of:
- aa) two antibody heavy chains consisting in N-terminal to C-terminal direction of an antibody heavy chain variable domain (VH), an antibody constant heavy chain domain 1 (CH1), an antibody hinge region (HR), an antibody heavy chain constant domain 2 (CH2), and an antibody heavy chain constant domain 3 (CH3); and
 - ab) two antibody light chains consisting in N-terminal to C-terminal direction of an antibody light chain variable domain (VL), and an antibody light chain constant domain (CL) (VL-CL).; and
- b) one single chain Fab fragment specifically binding to human c-Met), wherein the single chain Fab fragment consist of an antibody heavy chain variable domain (VH) and an antibody constant domain 1 (CH1), an antibody light chain variable domain (VL), an antibody light chain constant domain (CL) and a linker, and wherein the said antibody domains and said linker have one of the following orders in N-terminal to C-terminal direction:
- ba) VH-CH1-linker-VL-CL, or bb) VL-CL-linker-VH-CH1;
- wherein said linker is a peptide of at least 30 amino acids, preferably between 32 and 50 amino acids;
- and wherein said single chain Fab fragment under b) is fused to said full length antibody under a) via a peptide connector at the C- or N- terminus of the heavy or light chain (preferably at the C-terminus of the heavy chain) of said full length antibody;

- 31 -

wherein said peptide connector is a peptide of at least 5 amino acids,
preferably between 10 and 50 amino acids.

Within this embodiment, preferably the trivalent, bispecific antibody comprises a
T366W mutation in one of the two CH3 domains of and T366S, L368A, Y407V
5 mutations in the other of the two CH3 domains and more preferably the trivalent,
bispecific antibody comprises Y349C, T366W mutations in one of the two CH3
domains of and S354C (or E356C), T366S, L368A, Y407V mutations in the other
of the two CH3 domains. Optionally in said embodiment the trivalent, bispecific
antibody comprises R409D; K370E mutations in the CH3 domain of the “knobs
10 chain” and D399K; E357K mutations in the CH3 domain of the “hole chain”.

Another embodiment of the current invention is a trivalent, bispecific antibody
comprising

a) a full length antibody specifically binding to human ErbB-2 and consisting of:
aa) two antibody heavy chains consisting in N-terminal to C-terminal
15 direction of an antibody heavy chain variable domain (VH), an antibody
constant heavy chain domain 1 (CH1), an antibody hinge region (HR), an
antibody heavy chain constant domain 2 (CH2), and an antibody heavy
chain constant domain 3 (CH3); and
ab) two antibody light chains consisting in N-terminal to C-terminal
20 direction of an antibody light chain variable domain (VL), and an antibody
light chain constant domain (CL) (VL-CL).; and

b) one single chain Fv fragment specifically binding to human c-Met),

wherein said single chain Fv fragment under b) is fused to said full length
antibody under a) via a peptide connector at the C- or N- terminus of the
25 heavy or light chain (preferably at the C-terminus of the heavy chain) of
said full length antibody; and

wherein said peptide connector is a peptide of at least 5 amino acids,
preferably between 10 and 50 amino acids.

Within this embodiment, preferably the trivalent, bispecific antibody comprises a
30 T366W mutation in one of the two CH3 domains of and T366S, L368A, Y407V
mutations in the other of the two CH3 domains and more preferably the trivalent,
bispecific antibody comprises Y349C, T366W mutations in one of the two CH3

domains of and S354C (or E356C), T366S, L368A, Y407V mutations in the other of the two CH3 domains. Optionally in said embodiment the trivalent, bispecific antibody comprises R409D; K370E mutations in the CH3 domain of the “knobs chain” and D399K; E357K mutations in the CH3 domain of the “hole chain”.

5 Thus a preferred embodiment is a trivalent, bispecific antibody comprising

a) a full length antibody specifically binding to human ErbB-2 and consisting of:

10 aa) two antibody heavy chains consisting in N-terminal to C-terminal direction of an antibody heavy chain variable domain (VH), an antibody constant heavy chain domain 1 (CH1), an antibody hinge region (HR), an antibody heavy chain constant domain 2 (CH2), and an antibody heavy chain constant domain 3 (CH3); and

ab) two antibody light chains consisting in N-terminal to C-terminal direction of an antibody light chain variable domain (VL), and an antibody light chain constant domain (CL) (VL-CL).; and

15 b) one single chain Fv fragment specifically binding to human c-Met),

wherein said single chain Fv fragment under b) is fused to said full length antibody under a) via a peptide connector at the C - terminus of the heavy chain of said full length antibody (resulting in two antibody heavy chain-single chain Fv fusion peptides) ; and

20 wherein said peptide connector is a peptide of at least 5 amino acids,

Another embodiment of the current invention is a trivalent, bispecific antibody comprising

a) a full length antibody specifically binding to human ErbB-2 and consisting of:

25 aa) two antibody heavy chains consisting in N-terminal to C-terminal direction of an antibody heavy chain variable domain (VH), an antibody constant heavy chain domain 1 (CH1), an antibody hinge region (HR), an antibody heavy chain constant domain 2 (CH2), and an antibody heavy chain constant domain 3 (CH3); and

30 ab) two antibody light chains consisting in N-terminal to C-terminal direction of an antibody light chain variable domain (VL), and an antibody light chain constant domain (CL) ; and

- b) a polypeptide consisting of
- ba) an antibody heavy chain variable domain (VH); or
 - bb) an antibody heavy chain variable domain (VH) and an antibody constant domain 1 (CH1),
- 5 wherein said polypeptide is fused with the N-terminus of the VH domain via a peptide connector to the C-terminus of one of the two heavy chains of said full length antibody (resulting in an antibody heavy chain - VH fusion peptide) wherein said peptide connector is a peptide of at least 5 amino acids, preferably between 25 and 50 amino acids;
- 10 c) a polypeptide consisting of
- ca) an antibody light chain variable domain (VL), or
 - cb) an antibody light chain variable domain (VL) and an antibody light chain constant domain (CL);
- 15 wherein said polypeptide is fused with the N-terminus of the VL domain via a peptide connector to the C-terminus of the other of the two heavy chains of said full length antibody (resulting in an antibody heavy chain - VL fusion peptide);
- wherein said peptide connector is identical to the peptide connector under b);
- 20 and wherein the antibody heavy chain variable domain (VH) of the polypeptide under b) and the antibody light chain variable domain (VL) of the polypeptide under c) together form an antigen-binding site specifically binding to human c-Met

25 Within this embodiment, preferably the trivalent, bispecific antibody comprises a T366W mutation in one of the two CH3 domains of and T366S, L368A, Y407V mutations in the other of the two CH3 domains and more preferably the trivalent, bispecific antibody comprises Y349C, T366W mutations in one of the two CH3 domains of and S354C (or E356C), T366S, L368A, Y407V mutations in the other of the two CH3 domains. Optionally in said embodiment the trivalent, bispecific

30 antibody comprises R409D; K370E mutations in the CH3 domain of the “knobs chain” and D399K; E357K mutations in the CH3 domain of the “hole chain”.

In another aspect of the current invention the trivalent, bispecific antibody according to the invention comprises

- 5 a) a full length antibody binding to human ErbB-2 consisting of two antibody heavy chains VH-CH1-HR-CH2-CH3 and two antibody light chains VL-CL ;
(wherein preferably one of the two CH3 domains comprises Y349C, T366W mutations and the other of the two CH3 domains comprises S354C (or E356C), T366S, L368A, Y407V mutations);
- 10 b) a polypeptide consisting of
ba) an antibody heavy chain variable domain (VH); or
bb) an antibody heavy chain variable domain (VH) and an antibody constant domain 1 (CH1),
wherein said polypeptide is fused with the N-terminus of the VH domain via a peptide connector to the C-terminus of one of the two heavy chains of said full length antibody
- 15 c) a polypeptide consisting of
ca) an antibody light chain variable domain (VL), or
cb) an antibody light chain variable domain (VL) and an antibody light chain constant domain (CL);
wherein said polypeptide is fused with the N-terminus of the VL domain via a peptide connector to the C-terminus of the other of the two heavy chains of said full length antibody;
- 20 and wherein the antibody heavy chain variable domain (VH) of the polypeptide under b) and the antibody light chain variable domain (VL) of the polypeptide under c) together form an antigen-binding site specifically binding to human c-Met.

25 **Tetravalent bispecific formats**

In one embodiment the multispecific antibody according to the invention is tetravalent, wherein the antigen-binding site(s) that specifically bind to human c-Met, inhibit the c-Met dimerisation (as described e.g. in WO 2009/007427).

30 In one embodiment of the invention said antibody is a tetravalent, bispecific antibody specifically binding to human ErbB-2 and to human c-Met comprising two antigen-binding sites that specifically bind to human ErbB-2 and two antigen-binding sites that specifically bind to human c-Met, wherein said antigen-binding

sites that specifically bind to human c-Met inhibit the c-Met dimerisation (as described e.g. in WO 2009/007427).

Another aspect of the current invention therefore is a tetravalent, bispecific antibody comprising

- 5 a) a full length antibody specifically binding to human c-Met and consisting of two antibody heavy chains and two antibody light chains; and
- b) two identical single chain Fab fragments specifically binding to ErbB-2 ,
- wherein said single chain Fab fragments under b) are fused to said full length antibody under a) via a peptide connector at the C- or N- terminus of the heavy
- 10 or light chain of said full length antibody.

Another aspect of the current invention therefore is a tetravalent, bispecific antibody comprising

- a) a full length antibody specifically binding to human ErbB-2 and consisting of two antibody heavy chains and two antibody light chains; and
- 15 b) two identical single chain Fab fragments specifically binding to human c-Met,
- wherein said single chain Fab fragments under b) are fused to said full length antibody under a) via a peptide connector at the C- or N- terminus of the heavy or light chain of said full length antibody.

For an exemplary schematic structure see Fig 6a.

20 Another aspect of the current invention therefore is a tetravalent, bispecific antibody comprising

- a) a full length antibody specifically binding to ErbB-2, and consisting of two antibody heavy chains and two antibody light chains; and
- b) two identical single chain Fv fragments specifically binding to human c-Met,
- 25 wherein said single chain Fv fragments under b) are fused to said full length antibody under a) via a peptide connector at the C- or N- terminus of the heavy or light chain of said full length antibody.

Another aspect of the current invention therefore is a tetravalent, bispecific antibody comprising

a) a full length antibody specifically binding to human c-Met and consisting of two antibody heavy chains and two antibody light chains; and

5 b) two identical single chain Fv fragments specifically binding to ErbB-2,

wherein said single chain Fv fragments under b) are fused to said full length antibody under a) via a peptide connector at the C- or N- terminus of the heavy or light chain of said full length antibody.

For an exemplary schematic structure see Fig 6b.

10 In one preferred embodiment said single chain Fab or Fv fragments binding human c-Met or human ErbB-2 are fused to said full length antibody via a peptide connector at the C-terminus of the heavy chains of said full length antibody.

Another embodiment of the current invention is a tetravalent, bispecific antibody comprising

15 a) a full length antibody specifically binding to human ErbB-2 and consisting of:
aa) two identical antibody heavy chains consisting in N-terminal to C-terminal direction of an antibody heavy chain variable domain (VH), an antibody constant heavy chain domain 1 (CH1), an antibody hinge region (HR), an antibody heavy chain constant domain 2 (CH2), and an antibody
20 heavy chain constant domain 3 (CH3); and

ab) two identical antibody light chains consisting in N-terminal to C-terminal direction of an antibody light chain variable domain (VL), and an antibody light chain constant domain (CL) (VL-CL).; and

b) two single chain Fab fragments specifically binding to human c-Met,

25 wherein the single chain Fab fragments consist of an antibody heavy chain variable domain (VH) and an antibody constant domain 1 (CH1), an antibody light chain variable domain (VL), an antibody light chain constant domain (CL) and a linker, and wherein the said antibody domains and said linker have one of the following orders in N-terminal to C-terminal
30 direction:

ba) VH-CH1-linker-VL-CL, or bb) VL-CL-linker-VH-CH1;

wherein said linker is a peptide of at least 30 amino acids, preferably between 32 and 50 amino acids;

5 and wherein said single chain Fab fragments under b) are fused to said full length antibody under a) via a peptide connector at the C- or N- terminus of the heavy or light chain of said full length antibody;

wherein said peptide connector is a peptide of at least 5 amino acids, preferably between 10 and 50 amino acids.

The term "full length antibody" as used either in the trivalent or tetravalent format denotes an antibody consisting of two "full length antibody heavy chains" and two
10 "full length antibody light chains" (see Fig. 1). A "full length antibody heavy chain" is a polypeptide consisting in N-terminal to C-terminal direction of an antibody heavy chain variable domain (VH), an antibody constant heavy chain domain 1 (CH1), an antibody hinge region (HR), an antibody heavy chain constant domain 2 (CH2), and an antibody heavy chain constant domain 3 (CH3),
15 abbreviated as VH-CH1-HR-CH2-CH3; and optionally an antibody heavy chain constant domain 4 (CH4) in case of an antibody of the subclass IgE. Preferably the "full length antibody heavy chain" is a polypeptide consisting in N-terminal to C-terminal direction of VH, CH1, HR, CH2 and CH3. A "full length antibody light chain" is a polypeptide consisting in N-terminal to C-terminal direction of an
20 antibody light chain variable domain (VL), and an antibody light chain constant domain (CL), abbreviated as VL-CL. The antibody light chain constant domain (CL) can be κ (kappa) or λ (lambda). The two full length antibody chains are linked together via inter-polypeptide disulfide bonds between the CL domain and the CH1 domain and between the hinge regions of the full length antibody heavy chains.
25 Examples of typical full length antibodies are natural antibodies like IgG (e.g. IgG 1 and IgG2), IgM, IgA, IgD, and IgE. The full length antibodies according to the invention can be from a single species e.g. human, or they can be chimerized or humanized antibodies. The full length antibodies according to the invention comprise two antigen binding sites each formed by a pair of VH and VL, which
30 both specifically bind to the same antigen. The C-terminus of the heavy or light chain of said full length antibody denotes the last amino acid at the C-terminus of said heavy or light chain. The N-terminus of the heavy or light chain of said full length antibody denotes the last amino acid at the N- terminus of said heavy or light chain.

The term "peptide connector" as used within the invention denotes a peptide with amino acid sequences, which is preferably of synthetic origin. These peptide connectors according to invention are used to fuse the single chain Fab fragments to the C-or N-terminus of the full length antibody to form a multispecific antibody according to the invention. Preferably said peptide connectors under b) are peptides with an amino acid sequence with a length of at least 5 amino acids, preferably with a length of 5 to 100, more preferably of 10 to 50 amino acids. In one embodiment said peptide connector is $(GxS)_n$ or $(GxS)_nG_m$ with G = glycine, S = serine, and $(x = 3, n = 3, 4, 5$ or 6, and $m = 0, 1, 2$ or 3) or $(x = 4, n = 2, 3, 4$ or 5 and $m = 0, 1, 2$ or 3), preferably $x = 4$ and $n = 2$ or 3, more preferably with $x = 4, n = 2$. Preferably in the trivalent, bispecific antibodies wherein a VH or a VH-CH1 polypeptide and a VL or a VL-C L polypeptide (Fig. 7a -c) are fused via two identical peptide connectors to the C-terminus of a full length antibody, said peptide connectors are peptides of at least 25 amino acids, preferably peptides between 30 and 50 amino acids and more preferably said peptide connector is $(GxS)_n$ or $(GxS)_nG_m$ with G = glycine, S = serine, and $(x = 3, n = 6, 7$ or 8, and $m = 0, 1, 2$ or 3) or $(x = 4, n = 5, 6,$ or 7 and $m = 0, 1, 2$ or 3), preferably $x = 4$ and $n = 5, 6, 7$.

A "single chain Fab fragment" (see Fig2a) is a polypeptide consisting of an antibody heavy chain variable domain (VH), an antibody constant domain 1 (CH1), an antibody light chain variable domain (VL), an antibody light chain constant domain (CL) and a linker, wherein said antibody domains and said linker have one of the following orders in N-terminal to C-terminal direction: a) VH-CH1-linker-VL-CL, b) VL-CL-linker-VH-CH1, c) VH-CL-linker-VL-CH1 or d) VL-CH1-linker-VH-CL; and wherein said linker is a polypeptide of at least 30 amino acids, preferably between 32 and 50 amino acids. Said single chain Fab fragments a) VH-CH1-linker-VL-CL, b) VL-CL-linker-VH-CH1, c) VH-CL-linker-VL-CH1 and d) VL-CH1-linker-VH-CL, are stabilized via the natural disulfide bond between the CL domain and the CH1 domain. The term "N-terminus denotes the last amino acid of the N-terminus, The term "C-terminus denotes the last amino acid of the C-terminus.

The term "linker" is used within the invention in connection with single chain Fab fragments and denotes a peptide with amino acid sequences, which is preferably of synthetic origin. These peptides according to invention are used to link a) VH-CH1 to VL-CL, b) VL-CL to VH-CH1, c) VH-CL to VL-CH1 or d) VL-CH1 to VH-CL

- to form the following single chain Fab fragments according to the invention a) VH-CH1-linker-VL-CL, b) VL-CL-linker-VH-CH1, c) VH-CL-linker-VL-CH1 or d) VL-CH1-linker-VH-CL. Said linker within the single chain Fab fragments is a peptide with an amino acid sequence with a length of at least 30 amino acids, preferably with a length of 32 to 50 amino acids. In one embodiment said linker is (G_xS)_n with G = glycine, S = serine, (x = 3, n = 8, 9 or 10 and m = 0, 1, 2 or 3) or (x = 4 and n = 6, 7 or 8 and m = 0, 1, 2 or 3), preferably with x = 4, n = 6 or 7 and m = 0, 1, 2 or 3, more preferably with x = 4, n = 7 and m = 2. In one embodiment said linker is (G₄S)₆G₂.
- 5
- 10 In a preferred embodiment said antibody domains and said linker in said single chain Fab fragment have one of the following orders in N-terminal to C-terminal direction:
a) VH-CH1-linker-VL-CL, or b) VL-CL-linker-VH-CH1, more preferably VL-CL-linker-VH-CH1.
- 15 In another preferred embodiment said antibody domains and said linker in said single chain Fab fragment have one of the following orders in N-terminal to C-terminal direction:
a) VH-CL-linker-VL-CH1 or b) VL-CH1-linker-VH-CL.
- 20 Optionally in said single chain Fab fragment, additionally to the natural disulfide bond between the CL-domain and the CH1 domain, also the antibody heavy chain variable domain (VH) and the antibody light chain variable domain (VL) are disulfide stabilized by introduction of a disulfide bond between the following positions:
i) heavy chain variable domain position 44 to light chain variable domain position
25 100,
ii) heavy chain variable domain position 105 to light chain variable domain position 43, or
iii) heavy chain variable domain position 101 to light chain variable domain position 100 (numbering always according to EU index of Kabat).
- 30 Such further disulfide stabilization of single chain Fab fragments is achieved by the introduction of a disulfide bond between the variable domains VH and VL of the single chain Fab fragments. Techniques to introduce unnatural disulfide bridges for stabilization for a single chain Fv are described e.g. in WO 94/029350, Rajagopal, V., et al., Prot. Engin. (1997) 1453-59; Kobayashi, H., et al., Nuclear Medicine &

Biology 25 (1998) 387-393; or Schmidt, M., et al., Oncogene 18 (1999) 1711-1721. In one embodiment the optional disulfide bond between the variable domains of the single chain Fab fragments comprised in the antibody according to the invention is between heavy chain variable domain position 44 and light chain variable domain position 100. In one embodiment the optional disulfide bond between the variable domains of the single chain Fab fragments comprised in the antibody according to the invention is between heavy chain variable domain position 105 and light chain variable domain position 43 (numbering always according to EU index of Kabat).

10 In an embodiment single chain Fab fragment without said optional disulfide stabilization between the variable domains VH and VL of the single chain Fab fragments are preferred.

A "single chain Fv fragment" (see Fig2b) is a polypeptide consisting of an antibody heavy chain variable domain (VH), an antibody light chain variable domain (VL), and a single-chain-Fv-linker, wherein said antibody domains and said single-chain-Fv-linker have one of the following orders in N-terminal to C-terminal direction: a) VH-single-chain-Fv-linker-VL, b) VL-single-chain-Fv-linker-VH; preferably a) VH-single-chain-Fv-linker-VL, and wherein said single-chain-Fv-linker is a polypeptide of with an amino acid sequence with a length of at least 15 amino acids, in one embodiment with a length of at least 20 amino acids. The term "N-terminus denotes the last amino acid of the N-terminus, The term "C-terminus denotes the last amino acid of the C-terminus.

25 The term "single-chain-Fv-linker" as used within single chain Fv fragment denotes a peptide with amino acid sequences, which is preferably of synthetic origin. Said single-chain-Fv-linker is a peptide with an amino acid sequence with a length of at least 15 amino acids, in one embodiment with a length of at least 20 amino acids and preferably with a length between 15 and 30 amino acids. In one embodiment said single-chain-linker is $(G_xS)_n$ with G = glycine, S = serine, ($x = 3$ and $n = 4, 5$ or 6) or ($x = 4$ and $n = 3, 4, 5$ or 6), preferably with $x = 4, n = 3, 4$ or 5 , more preferably with $x = 4, n = 3$ or 4 . In one embodiment said single-chain-Fv-linker is $(G_4S)_3$ or $(G_4S)_4$.

30 Furthermore said single chain Fv fragments are preferably disulfide stabilized. Such further disulfide stabilization of single chain antibodies is achieved by the introduction of a disulfide bond between the variable domains of the single chain

antibodies and is described e.g. in WO 94/029350, Rajagopal, V., et al., Prot. Engin. 10 (1997) 1453-59; Kobayashi, H., et al., Nuclear Medicine & Biology 25 (1998) 387-393; or Schmidt, M., et al., Oncogene 18 (1999) 1711-1721.

5 In one embodiment of the disulfide stabilized single chain Fv fragments, the disulfide bond between the variable domains of the single chain Fv fragments comprised in the antibody according to the invention is independently for each single chain Fv fragment selected from:

- i) heavy chain variable domain position 44 to light chain variable domain position 100,
- 10 ii) heavy chain variable domain position 105 to light chain variable domain position 43, or
- iii) heavy chain variable domain position 101 to light chain variable domain position 100.

15 In one embodiment the disulfide bond between the variable domains of the single chain Fv fragments comprised in the antibody according to the invention is between heavy chain variable domain position 44 and light chain variable domain position 100.

The antibody according to the invention is produced by recombinant means. Thus, one aspect of the current invention is a nucleic acid encoding the antibody
20 according to the invention and a further aspect is a cell comprising said nucleic acid encoding an antibody according to the invention. Methods for recombinant production are widely known in the state of the art and comprise protein expression in prokaryotic and eukaryotic cells with subsequent isolation of the antibody and usually purification to a pharmaceutically acceptable purity. For the expression of
25 the antibodies as aforementioned in a host cell, nucleic acids encoding the respective modified light and heavy chains are inserted into expression vectors by standard methods. Expression is performed in appropriate prokaryotic or eukaryotic host cells like CHO cells, NS0 cells, SP2/0 cells, HEK293 cells, COS cells, PER.C6 cells, yeast, or E.coli cells, and the antibody is recovered from the cells
30 (supernatant or cells after lysis). General methods for recombinant production of antibodies are well-known in the state of the art and described, for example, in the review articles of Makrides, S.C., Protein Expr. Purif. 17 (1999) 183-202; Geisse, S., et al., Protein Expr. Purif. 8 (1996) 271-282; Kaufman, R.J., Mol. Biotechnol. 16 (2000) 151-160; Werner, R., G., Drug Res. 48 (1998) 870-880.

The bispecific antibodies are suitably separated from the culture medium by conventional immunoglobulin purification procedures such as, for example, protein A-Sepharose, hydroxylapatite chromatography, gel electrophoresis, dialysis, or affinity chromatography. DNA and RNA encoding the monoclonal antibodies is readily isolated and sequenced using conventional procedures. The hybridoma cells can serve as a source of such DNA and RNA. Once isolated, the DNA may be inserted into expression vectors, which are then transfected into host cells such as HEK 293 cells, CHO cells, or myeloma cells that do not otherwise produce immunoglobulin protein, to obtain the synthesis of recombinant monoclonal antibodies in the host cells.

Amino acid sequence variants (or mutants) of the bispecific antibody are prepared by introducing appropriate nucleotide changes into the antibody DNA, or by nucleotide synthesis. Such modifications can be performed, however, only in a very limited range, e.g. as described above. For example, the modifications do not alter the above mentioned antibody characteristics such as the IgG isotype and antigen binding, but may improve the yield of the recombinant production, protein stability or facilitate the purification.

The term "host cell" as used in the current application denotes any kind of cellular system which can be engineered to generate the antibodies according to the current invention. In one embodiment HEK293 cells and CHO cells are used as host cells. As used herein, the expressions "cell," "cell line," and "cell culture" are used interchangeably and all such designations include progeny. Thus, the words "transformants" and "transformed cells" include the primary subject cell and cultures derived therefrom without regard for the number of transfers. It is also understood that all progeny may not be precisely identical in DNA content, due to deliberate or inadvertent mutations. Variant progeny that have the same function or biological activity as screened for in the originally transformed cell are included.

Expression in NS0 cells is described by, e.g., Barnes, L.M., et al., *Cytotechnology* 32 (2000) 109-123; Barnes, L.M., et al., *Biotech. Bioeng.* 73 (2001) 261-270. Transient expression is described by, e.g., Durocher, Y., et al., *Nucl. Acids. Res.* 30 (2002) E9. Cloning of variable domains is described by Orlandi, R., et al., *Proc. Natl. Acad. Sci. USA* 86 (1989) 3833-3837; Carter, P., et al., *Proc. Natl. Acad. Sci. USA* 89 (1992) 4285-4289; and Norderhaug, L., et al., *J. Immunol. Methods* 204 (1997) 77-87. A preferred transient expression system (HEK 293) is described by

Schlaeger, E.-J., and Christensen, K., in *Cytotechnology* 30 (1999) 71-83 and by Schlaeger, E.-J., in *J. Immunol. Methods* 194 (1996) 191-199.

5 The control sequences that are suitable for prokaryotes, for example, include a promoter, optionally an operator sequence, and a ribosome binding site. Eukaryotic cells are known to utilize promoters, enhancers and polyadenylation signals.

10 A nucleic acid is "operably linked" when it is placed in a functional relationship with another nucleic acid sequence. For example, DNA for a pre-sequence or secretory leader is operably linked to DNA for a polypeptide if it is expressed as a pre-protein that participates in the secretion of the polypeptide; a promoter or enhancer is operably linked to a coding sequence if it affects the transcription of the sequence; or a ribosome binding site is operably linked to a coding sequence if it is positioned so as to facilitate translation. Generally, "operably linked" means that the DNA sequences being linked are contiguous, and, in the case of a secretory leader, contiguous and in reading frame. However, enhancers do not have to be
15 contiguous. Linking is accomplished by ligation at convenient restriction sites. If such sites do not exist, the synthetic oligonucleotide adaptors or linkers are used in accordance with conventional practice.

20 Purification of antibodies is performed in order to eliminate cellular components or other contaminants, e.g. other cellular nucleic acids or proteins, by standard techniques, including alkaline/SDS treatment, CsCl banding, column chromatography, agarose gel electrophoresis, and others well known in the art. See Ausubel, F., et al., ed. *Current Protocols in Molecular Biology*, Greene Publishing and Wiley Interscience, New York (1987). Different methods are well established and widespread used for protein purification, such as affinity chromatography with
25 microbial proteins (e.g. protein A or protein G affinity chromatography), ion exchange chromatography (e.g. cation exchange (carboxymethyl resins), anion exchange (amino ethyl resins) and mixed-mode exchange), thiophilic adsorption (e.g. with beta-mercaptoethanol and other SH ligands), hydrophobic interaction or aromatic adsorption chromatography (e.g. with phenyl-sepharose, aza-arenophilic
30 resins, or m-aminophenylboronic acid), metal chelate affinity chromatography (e.g. with Ni(II)- and Cu(II)-affinity material), size exclusion chromatography, and electrophoretical methods (such as gel electrophoresis, capillary electrophoresis) (Vijayalakshmi, M., A., *Appl. Biochem. Biotech.* 75 (1998) 93-102).

As used herein, the expressions "cell," "cell line," and "cell culture" are used interchangeably and all such designations include progeny. Thus, the words "transformants" and "transformed cells" include the primary subject cell and cultures derived therefrom without regard for the number of transfers. It is also understood that all progeny may not be precisely identical in DNA content, due to deliberate or inadvertent mutations. Variant progeny that have the same function or biological activity as screened for in the originally transformed cell are included. Where distinct designations are intended, it will be clear from the context.

The term "transformation" as used herein refers to process of transfer of a vectors/nucleic acid into a host cell. If cells without formidable cell wall barriers are used as host cells, transfection is carried out e.g. by the calcium phosphate precipitation method as described by Graham, F.L., and van der Eb, A.J., *Virology* 52 (1973) 456-467. However, other methods for introducing DNA into cells such as by nuclear injection or by protoplast fusion may also be used. If prokaryotic cells or cells which contain substantial cell wall constructions are used, e.g. one method of transfection is calcium treatment using calcium chloride as described by Cohen, S.N., et al., *PNAS*. 69 (1972) 2110-2114.

As used herein, "expression" refers to the process by which a nucleic acid is transcribed into mRNA and/or to the process by which the transcribed mRNA (also referred to as transcript) is subsequently being translated into peptides, polypeptides, or proteins. The transcripts and the encoded polypeptides are collectively referred to as gene product. If the polynucleotide is derived from genomic DNA, expression in a eukaryotic cell may include splicing of the mRNA.

A "vector" is a nucleic acid molecule, in particular self-replicating, which transfers an inserted nucleic acid molecule into and/or between host cells. The term includes vectors that function primarily for insertion of DNA or RNA into a cell (e.g., chromosomal integration), replication of vectors that function primarily for the replication of DNA or RNA, and expression vectors that function for transcription and/or translation of the DNA or RNA. Also included are vectors that provide more than one of the functions as described.

An "expression vector" is a polynucleotide which, when introduced into an appropriate host cell, can be transcribed and translated into a polypeptide. An "expression system" usually refers to a suitable host cell comprised of an expression vector that can function to yield a desired expression product.

Pharmaceutical composition

- 5 One aspect of the invention is a pharmaceutical composition comprising an antibody according to the invention. Another aspect of the invention is the use of an antibody according to the invention for the manufacture of a pharmaceutical composition. A further aspect of the invention is a method for the manufacture of a pharmaceutical composition comprising an antibody according to the invention. In another aspect, the present invention provides a composition, e.g. a pharmaceutical composition, containing an antibody according to the present invention, formulated together with a pharmaceutical carrier.
- 10 One embodiment of the invention is the bispecific antibody according to the invention for the treatment of cancer.
- Another aspect of the invention is said pharmaceutical composition for the treatment of cancer.
- Another aspect of the invention is the use of an antibody according to the invention for the manufacture of a medicament for the treatment of cancer.
- 15 Another aspect of the invention is method of treatment of patient suffering from cancer by administering an antibody according to the invention to a patient in the need of such treatment.
- 20 As used herein, "pharmaceutical carrier" includes any and all solvents, dispersion media, coatings, antibacterial and antifungal agents, isotonic and absorption delaying agents, and the like that are physiologically compatible. Preferably, the carrier is suitable for intravenous, intramuscular, subcutaneous, parenteral, spinal or epidermal administration (e.g. by injection or infusion).
- 25 A composition of the present invention can be administered by a variety of methods known in the art. As will be appreciated by the skilled artisan, the route and/or mode of administration will vary depending upon the desired results. To administer a compound of the invention by certain routes of administration, it may be necessary to coat the compound with, or co-administer the compound with, a material to prevent its inactivation. For example, the compound may be administered to a subject in an appropriate carrier, for example, liposomes, or a diluent. Pharmaceutically acceptable diluents include saline and aqueous buffer solutions. Pharmaceutical carriers include sterile aqueous solutions or dispersions and sterile powders for the extemporaneous preparation of sterile injectable
- 30

solutions or dispersion. The use of such media and agents for pharmaceutically active substances is known in the art.

The phrases "parenteral administration" and "administered parenterally" as used herein means modes of administration other than enteral and topical administration, usually by injection, and includes, without limitation, intravenous, intramuscular, 5 intra-arterial, intrathecal, intracapsular, intraorbital, intracardiac, intradermal, intraperitoneal, transtracheal, subcutaneous, subcuticular, intra-articular, subcapsular, subarachnoid, intraspinal, epidural and intrasternal injection and infusion.

10 The term cancer as used herein refers to proliferative diseases, such as lymphomas, lymphocytic leukemias, lung cancer, non small cell lung (NSCL) cancer, bronchioloalviolar cell lung cancer, bone cancer, pancreatic cancer, skin cancer, cancer of the head or neck, cutaneous or intraocular melanoma, uterine cancer, ovarian cancer, rectal cancer, cancer of the anal region, stomach cancer, gastric 15 cancer, colon cancer, breast cancer, uterine cancer, carcinoma of the fallopian tubes, carcinoma of the endometrium, carcinoma of the cervix, carcinoma of the vagina, carcinoma of the vulva, Hodgkin's Disease, cancer of the esophagus, cancer of the small intestine, cancer of the endocrine system, cancer of the thyroid gland, cancer of the parathyroid gland, cancer of the adrenal gland, sarcoma of soft tissue, 20 cancer of the urethra, cancer of the penis, prostate cancer, cancer of the bladder, cancer of the kidney or ureter, renal cell carcinoma, carcinoma of the renal pelvis, mesothelioma, hepatocellular cancer, biliary cancer, neoplasms of the central nervous system (CNS), spinal axis tumors, brain stem glioma, glioblastoma multiforme, astrocytomas, schwannomas, ependymomas, medulloblastomas, 25 meningiomas, squamous cell carcinomas, pituitary adenoma and Ewings sarcoma, including refractory versions of any of the above cancers, or a combination of one or more of the above cancers.

Another aspect of the invention is the bispecific antibody according to the invention or said pharmaceutical composition as anti-angiogenic agent. Such anti-angiogenic agent can be used for the treatment of cancer, especially solid tumors, 30 and other vascular diseases.

One embodiment of the invention is the bispecific, antibody according to the invention for the treatment of vascular diseases.

Another aspect of the invention is the use of an antibody according to the invention for the manufacture of a medicament for the treatment of vascular diseases.

5 Another aspect of the invention is method of treatment of patient suffering from vascular diseases by administering an antibody according to the invention to a patient in the need of such treatment.

The term "vascular diseases" includes Cancer, Inflammatory diseases, Atherosclerosis, Ischemia, Trauma, Sepsis, COPD, Asthma, Diabetes, AMD, Retinopathy, Stroke, Adipositas, Acute lung injury, Hemorrhage, Vascular leak e.g. Cytokine induced, Allergy, Graves' Disease , Hashimoto's Autoimmune
10 Thyroiditis, Idiopathic Thrombocytopenic Purpura, Giant Cell Arteritis, Rheumatoid Arthritis, Systemic Lupus Erythematosus (SLE), Lupus Nephritis, Crohn's Disease, Multiple Sclerosis, Ulcerative Colitis, especially to solid tumors, intraocular neovascular syndromes such as proliferative retinopathies or age-related macular degeneration (AMD), rheumatoid arthritis, and psoriasis (Folkman, J., et
15 al., J. Biol. Chem. 267 (1992) 10931- 10934; Klagsbrun, et al., Annu. Rev. Physiol. 53 (1991) 217-239; and Garner, A., Vascular diseases, In: Pathobiology of ocular disease, A dynamic approach, Garner, A., and Klintworth, G. K., (eds.), 2nd edition, Marcel Dekker, New York (1994) 1625-1710).

20 These compositions may also contain adjuvants such as preservatives, wetting agents, emulsifying agents and dispersing agents. Prevention of presence of microorganisms may be ensured both by sterilization procedures, supra, and by the inclusion of various antibacterial and antifungal agents, for example, paraben, chlorobutanol, phenol, sorbic acid, and the like. It may also be desirable to include isotonic agents, such as sugars, sodium chloride, and the like into the compositions.
25 In addition, prolonged absorption of the injectable pharmaceutical form may be brought about by the inclusion of agents which delay absorption such as aluminum monostearate and gelatin.

Regardless of the route of administration selected, the compounds of the present invention, which may be used in a suitable hydrated form, and/or the
30 pharmaceutical compositions of the present invention, are formulated into pharmaceutically acceptable dosage forms by conventional methods known to those of skill in the art.

Actual dosage levels of the active ingredients in the pharmaceutical compositions of the present invention may be varied so as to obtain an amount of the active ingredient which is effective to achieve the desired therapeutic response for a particular patient, composition, and mode of administration, without being toxic to the patient. The selected dosage level will depend upon a variety of pharmacokinetic factors including the activity of the particular compositions of the present invention employed, the route of administration, the time of administration, the rate of excretion of the particular compound being employed, the duration of the treatment, other drugs, compounds and/or materials used in combination with the particular compositions employed, the age, sex, weight, condition, general health and prior medical history of the patient being treated, and like factors well known in the medical arts.

The composition must be sterile and fluid to the extent that the composition is deliverable by syringe. In addition to water, the carrier preferably is an isotonic buffered saline solution.

Proper fluidity can be maintained, for example, by use of coating such as lecithin, by maintenance of required particle size in the case of dispersion and by use of surfactants. In many cases, it is preferable to include isotonic agents, for example, sugars, polyalcohols such as mannitol or sorbitol, and sodium chloride in the composition.

It has now been found that the bispecific antibodies against human ErbB-2 and human c-Met according to the current invention have valuable characteristics such as biological or pharmacological activity.

The following examples, sequence listing and figures are provided to aid the understanding of the present invention, the true scope of which is set forth in the appended claims. It is understood that modifications can be made in the procedures set forth without departing from the spirit of the invention.

Description of the Amino acid Sequences

SEQ ID NO:1 heavy chain variable domain <ErbB-2> trastuzumab
SEQ ID NO:2 light chain variable domain < ErbB-2> trastuzumab
SEQ ID NO:3 heavy chain variable domain <c-Met> Mab 5D5
SEQ ID NO:4 light chain variable domain <c-Met> Mab 5D5
SEQ ID NO:5 heavy chain <c-Met> Mab 5D5

	SEQ ID NO:6	light chain <c-Met> Mab 5D5
	SEQ ID NO:7	heavy chain <c-Met> Fab 5D5
	SEQ ID NO:8	light chain <c-Met> Fab 5D5
	SEQ ID NO:9	heavy chain constant region of human IgG1
5	SEQ ID NO:10	heavy chain constant region of human IgG3
	SEQ ID NO:11	human light chain kappa constant region
	SEQ ID NO:12	human light chain lambda constant region
	SEQ ID NO:13	human c-Met
	SEQ ID NO:14	human ErbB-2
10	SEQ ID NO:15	heavy chain CDR3H, <ErbB-2> trastuzumab
	SEQ ID NO:16	heavy chain CDR2H, <ErbB-2> trastuzumab
	SEQ ID NO:17	heavy chain CDR1H, <ErbB-2> trastuzumab
	SEQ ID NO:18	light chain CDR3L, <ErbB-2> trastuzumab
	SEQ ID NO:19	light chain CDR2L, <ErbB-2> trastuzumab
15	SEQ ID NO:20	light chain CDR1L, <ErbB-2> trastuzumab
	SEQ ID NO:21	heavy chain CDR3H, <c-Met> Mab 5D5
	SEQ ID NO:22	heavy chain CDR2H, <c-Met> Mab 5D5
	SEQ ID NO:23	heavy chain CDR1H, <c-Met> Mab 5D5
	SEQ ID NO: 24	light chain CDR3L, <c-Met> Mab 5D5
20	SEQ ID NO: 25	light chain CDR2L, <c-Met> Mab 5D5
	SEQ ID NO: 26	light chain CDR1L, <c-Met> Mab 5D5

Description of the Figures

25 **Figure 1** Schematic structure of a full length antibody without CH4 domain specifically binding to a first antigen 1 with two pairs of heavy and light chain which comprise variable and constant domains in a typical order.

30 **Figure 2a-c** Schematic structure of a bivalent, bispecific <ErbB-2/ c-Met> antibody, comprising: a) the light chain and heavy chain of a full length antibody specifically binding to human ErbB-2; and b) the light chain and heavy chain of a full length antibody specifically binding to human c-Met, wherein the constant domains CL and CH1, and/or the variable domains

35

- VL and VH are replaced by each other, which are modified with knobs-into hole technology.
- Figure 3** Schematic representation of a trivalent, bispecific <ErbB-2/c-Met> antibody according to the invention, comprising a full length antibody specifically binding to ErbB-2 to which
- 5
- a) **Fig 3a:** two polypeptides VH and VL are fused (the VH and VL domains of both together forming a antigen binding site specifically binding to c-Met;
- 10
- b) **Fig 3b:** two polypeptides VH-CH1 and VL-CL are fused (the VH and VL domains of both together forming a antigen binding site specifically binding to c-Met)
- Fig 3c:** Schematic representation of a trivalent, bispecific antibody according to the invention, comprising a full length antibody specifically binding to ErbB-2 to which two polypeptides VH and VL are fused (the VH and VL domains of both together forming a antigen binding site specifically binding to c-Met) with “knobs and holes”.
- 15
- Fig 3d:** Schematic representation of a trivalent, bispecific antibody according to the invention, comprising a full length antibody specifically binding to ErbB-2 to which two polypeptides VH and VL are fused (the VH and VL domains of both together forming a antigen binding site specifically binding to c-Met, wherein these VH and VL domains comprise an interchain disulfide bridge between positions VH44 and VL100) with “knobs and holes”.
- 20
- Figure 4** **4a:** Schematic structure of the four possible single chain Fab fragments
- 25
- 4b:** Schematic structure of the two single chain Fv fragments
- Figure 5** Schematic structure of a trivalent, bispecific <ErbB-2/c-Met> antibody comprising a full length antibody and one single chain Fab fragment (**Fig 5a**) or one
- 30
- 35

- single chain Fv fragment (**Fig 5b**) - bispecific trivalent example with knobs and holes
- Figure 6** Schematic structure of a tetravalent, bispecific <ErbB-2/c-Met> antibody comprising a full length antibody and two single chain Fab fragments (**Fig 6a**) or two single chain Fv fragments (**Fig 6b**) –the c-Met binding sites are derived from c-Met dimerisation inhibiting antibodies
- 5
- Figure 7a** Flow cytometric analysis of cell surface expression of ErbB1/2/3 and c-Met in the epidermoid cancer cell line A431.
- 10
- Figure 7b** Flow cytometric analysis of cell surface expression of ErbB1/2/3 and c-Met in the ovarian cancer cell line OVCAR-8.
- 15
- Figure 8** Internalization assay in OVCAR-8 cancer cells measured at 0 , 30, 60 and 120 minutes (= 0, 0.5, 1, and 2 hours).
- Figure 9a** Proliferation assay in OVCAR-8 cancer cells. Inhibition of Cancer cell proliferation of the bispecific <HER2/c-Met> antibody BsAB02 (BsAb) according to the invention compared with the monospecific parent <HER2> and <c-Met> antibodies.
- 20
- Figure 9b** Proliferation assay in the cancer cell line OvcAR-8 in the presence of HGF- Inhibition of Cancer cell proliferation of the bispecific <HER2/c-Met> antibody BsAB02 (BsAb) according to the invention compared with the monospecific parent <HER2> and <c-Met> antibodies.
- 25

Experimental Procedure

Examples

Materials & Methods

Recombinant DNA techniques

5 Standard methods were used to manipulate DNA as described in Sambrook, J. et al., Molecular cloning: A laboratory manual; Cold Spring Harbor Laboratory Press, Cold Spring Harbor, New York, 1989. The molecular biological reagents were used according to the manufacturer's instructions.

DNA and protein sequence analysis and sequence data management

10 General information regarding the nucleotide sequences of human immunoglobulins light and heavy chains is given in: Kabat, E.A., et al., (1991) Sequences of Proteins of Immunological Interest, Fifth Ed., NIH Publication No 91-3242. Amino acids of antibody chains are numbered according to EU numbering (Edelman, G.M., et al., PNAS 63 (1969) 78-85; Kabat, E.A., et al.,
15 (1991) Sequences of Proteins of Immunological Interest, Fifth Ed., NIH Publication No 91-3242). The GCG's (Genetics Computer Group, Madison, Wisconsin) software package version 10.2 and Infomax's Vector NTI Advance suite version 8.0 was used for sequence creation, mapping, analysis, annotation and illustration.

DNA sequencing

20 DNA sequences were determined by double strand sequencing performed at SequiServe (Vaterstetten, Germany) and Genart AG (Regensburg, Germany).

Gene synthesis

25 Desired gene segments were prepared by Genart AG (Regensburg, Germany) from synthetic oligonucleotides and PCR products by automated gene synthesis. The gene segments which are flanked by singular restriction endonuclease cleavage sites were cloned into pGA18 (ampR) plasmids. The plasmid DNA was purified from transformed bacteria and concentration determined by UV spectroscopy. The DNA sequence of the subcloned gene fragments was confirmed by DNA
30 sequencing. In a similar manner, DNA sequences coding modified "knobs-into-hole" <ErbB-2> antibody heavy chain carrying S354C and T366W mutations in the CH3 domain with/without a C-terminal <c-Met>5D5 scFab VH region linked by a peptide connector as well as "knobs-into-hole" <ErbB-2>antibody heavy chain carrying Y349C, T366S, L368A and Y407V mutations with/without a C-terminal

<c-Met>5D5 scFab VL region linked by a peptide connector were prepared by gene synthesis with flanking BamHI and XbaI restriction sites. Finally, DNA sequences encoding unmodified heavy and light chains of <ErbB-2> antibodies and <c-Met>5D5 antibody were synthesized with flanking BamHI and XbaI restriction sites. All constructs were designed with a 5'-end DNA sequence coding for a leader peptide (MGWSCIILFLVATATGVHS), which targets proteins for secretion in eukaryotic cells.

Construction of the expression plasmids

A Roche expression vector was used for the construction of all heavy and light chain scFv fusion protein encoding expression plasmids. The vector is composed of the following elements:

- a hygromycin resistance gene as a selection marker,
- an origin of replication, oriP, of Epstein-Barr virus (EBV),
- an origin of replication from the vector pUC18 which allows replication of this plasmid in E. coli
- a beta-lactamase gene which confers ampicillin resistance in E. coli,
- the immediate early enhancer and promoter from the human cytomegalovirus (HCMV),
- the human 1-immunoglobulin polyadenylation ("poly A") signal sequence, and
- unique BamHI and XbaI restriction sites.

The immunoglobulin fusion genes comprising the heavy or light chain constructs as well as "knobs-into-hole" constructs with C-terminal VH and VL domains were prepared by gene synthesis and cloned into pGA18 (ampR) plasmids as described. The pG18 (ampR) plasmids carrying the synthesized DNA segments and the Roche expression vector were digested with BamHI and XbaI restriction enzymes (Roche Molecular Biochemicals) and subjected to agarose gel electrophoresis. Purified heavy and light chain coding DNA segments were then ligated to the isolated Roche expression vector BamHI/XbaI fragment resulting in the final expression vectors. The final expression vectors were transformed into E. coli cells, expression plasmid DNA was isolated (Miniprep) and subjected to restriction enzyme analysis and DNA sequencing. Correct clones were grown in 150 ml LB-Amp medium, again plasmid DNA was isolated (Maxiprep) and sequence integrity confirmed by DNA sequencing.

Transient expression of immunoglobulin variants in HEK293 cells

Recombinant immunoglobulin variants were expressed by transient transfection of human embryonic kidney 293-F cells using the FreeStyle™ 293 Expression System according to the manufacturer's instruction (Invitrogen, USA). Briefly, suspension
5 FreeStyle™ 293-F cells were cultivated in FreeStyle™ 293 Expression medium at 37°C/8 % CO₂ and the cells were seeded in fresh medium at a density of 1-2x10⁶ viable cells/ml on the day of transfection. DNA-293fectin™ complexes were prepared in Opti-MEM® I medium (Invitrogen, USA) using 325 µl of 293fectin™ (Invitrogen, Germany) and 250 µg of heavy and light chain plasmid DNA in a 1:1
10 molar ratio for a 250 ml final transfection volume. "Knobs-into-hole" DNA-293fectin complexes were prepared in Opti-MEM® I medium (Invitrogen, USA) using 325 µl of 293fectin™ (Invitrogen, Germany) and 250 µg of "Knobs-into-hole" heavy chain 1 and 2 and light chain plasmid DNA in a 1:1:2 molar ratio for a 250 ml final transfection volume. Antibody containing cell culture supernatants
15 were harvested 7 days after transfection by centrifugation at 14000 g for 30 minutes and filtered through a sterile filter (0.22 µm). Supernatants were stored at -20° C until purification.

Purification of bispecific and control antibodies

Trivalent bispecific and control antibodies were purified from cell culture supernatants by affinity chromatography using Protein A-Sepharose™ (GE
20 Healthcare, Sweden) and Superdex200 size exclusion chromatography. Briefly, sterile filtered cell culture supernatants were applied on a HiTrap ProteinA HP (5 ml) column equilibrated with PBS buffer (10 mM Na₂HPO₄, 1 mM KH₂PO₄, 137 mM NaCl and 2.7 mM KCl, pH 7.4). Unbound proteins were washed out with
25 equilibration buffer. Antibody and antibody variants were eluted with 0.1 M citrate buffer, pH 2.8, and the protein containing fractions were neutralized with 0.1 ml 1 M Tris, pH 8.5. Then, the eluted protein fractions were pooled, concentrated with an Amicon Ultra centrifugal filter device (MWCO: 30 K, Millipore) to a volume of 3 ml and loaded on a Superdex200 HiLoad 120 ml 16/60 gel filtration column (GE
30 Healthcare, Sweden) equilibrated with 20mM Histidin, 140 mM NaCl, pH 6.0. Fractions containing purified bispecific and control antibodies with less than 5 % high molecular weight aggregates were pooled and stored as 1.0 mg/ml aliquots at -80°C. Fab fragments were generated by a Papain digest of the purified 5D5 monoclonal antibody and subsequent removal of contaminating Fc domains by
35 Protein A chromatography. Unbound Fab fragments were further purified on a Superdex200 HiLoad 120 ml 16/60 gel filtration column (GE Healthcare, Sweden)

equilibrated with 20mM Histidin, 140 mM NaCl, pH 6.0, pooled and stored as 1.0 mg/ml aliquots at -80°C.

Analysis of purified proteins

The protein concentration of purified protein samples was determined by measuring the optical density (OD) at 280 nm, using the molar extinction coefficient calculated on the basis of the amino acid sequence. Purity and molecular weight of bispecific and control antibodies were analyzed by SDS-PAGE in the presence and absence of a reducing agent (5 mM 1,4-dithiotreitol) and staining with Coomassie brilliant blue. The NuPAGE® Pre-Cast gel system (Invitrogen, USA) was used according to the manufacturer's instruction (4-20 % Tris-Glycine gels). The aggregate content of bispecific and control antibody samples was analyzed by high-performance SEC using a Superdex 200 analytical size-exclusion column (GE Healthcare, Sweden) in 200 mM KH₂PO₄, 250 mM KCl, pH 7.0 running buffer at 25°C. 25 µg protein were injected on the column at a flow rate of 0.5 ml/min and eluted isocratic over 50 minutes. For stability analysis, concentrations of 1 mg/ml of purified proteins were incubated at 4°C and 40°C for 7 days and then evaluated by high-performance SEC. The integrity of the amino acid backbone of reduced bispecific antibody light and heavy chains was verified by NanoElectrospray Q-TOF mass spectrometry after removal of N-glycans by enzymatic treatment with Peptide-N-Glycosidase F (Roche Molecular Biochemicals).

c-Met phosphorylation assay

5x10⁵ A549 cells were seeded per well of a 6-well plate the day prior HGF stimulation in RPMI with 0.5 % FCS (fetal calf serum). The next day, growth medium was replaced for one hour with RPMI containing 0.2 % BSA (bovine serum albumine). 5 µg/mL of the bispecific antibody was then added to the medium and cells were incubated for 10 minutes upon which HGF was added for further 10 minutes in a final concentration of 50 ng/mL. Cells were washed once with ice cold PBS containing 1 mM sodium vanadate upon which they were placed on ice and lysed in the cell culture plate with 100 µL lysis buffer (50 mM Tris-Cl pH7.5, 150 mM NaCl, 1 % NP40, 0.5 % DOC, aprotinine, 0.5 mM PMSF, 1 mM sodium-vanadate). Cell lysates were transferred to eppendorf tubes and lysis was allowed to proceed for 30 minutes on ice. Protein concentration was determined using the BCA method (Pierce). 30-50 µg of the lysate was separated on a 4-12 % Bis-Tris NuPage gel (Invitrogen) and proteins on the gel were transferred to a

nitrocellulose membrane. Membranes were blocked for one hour with TBS-T containing 5 % BSA and developed with a phospho-specific c-Met antibody directed against Y1230,1234,1235 (44-888, Biosource) according to the manufacturer's instructions. Immunoblots were reprobed with an antibody binding to unphosphorylated c-Met (AF276, R&D).

ErbB2/Her2 phosphorylation assay

5x10⁵ Sk-Br3 cells are seeded per well of a 6-well plate the day prior antibody addition in RPMI with 10% FCS (fetal calf serum). The next day, 5 µg/mL of the control or bispecific antibodies are added to the medium and cells are incubated an additional hour. Cells are washed once with ice cold PBS containing 1 mM sodium vanadate upon which they are placed on ice and lysed in the cell culture plate with 100 µL lysis buffer (50 mM Tris-Cl pH7.5, 150 mM NaCl, 1% NP40, 0.5% DOC, aprotinine, 0.5 mM PMSF, 1 mM sodium-vanadate). Cell lysates are transferred to eppendorf tubes and lysis allowed to proceed for 30 minutes on ice. Protein concentration is determined using the BCA method (Pierce). 30-50 µg of the lysate are separated on a 4-12% Bis-Tris NuPage gel (Invitrogen) and proteins on the gel are transferred to a nitrocellulose membrane. Membranes are blocked for one hour with TBS-T containing 5% BSA and developed with a phospho-specific Her2 antibody directed against Y1221/22 (Cell Signaling, 2243) according to the manufacturer's instructions. Immunoblots are reprobed with an antibody binding to unphosphorylated Her2 (Cell Signaling, 2165).

AKT phosphorylation assay

5x10⁵ A431 cells are seeded per well of a 6-well plate the day prior antibody addition in RPMI with 10% FCS (fetal calf serum). The next day, 5 µg/mL of the control or bispecific antibodies are added to the medium and cells are incubated an additional hour. A subset of cells is then stimulated for an additional 15 min with 25 ng/mL HGF (R&D, 294-HGN). Cells are washed once with ice cold PBS containing 1 mM sodium vanadate upon which they are placed on ice and lysed in the cell culture plate with 100 µL lysis buffer (50 mM Tris-Cl pH7.5, 150 mM NaCl, 1% NP40, 0.5% DOC, aprotinine, 0.5 mM PMSF, 1 mM sodium-vanadate). Cell lysates are transferred to eppendorf tubes and lysis allowed to proceed for 30 minutes on ice. Protein concentration is determined using the BCA method (Pierce). 30-50 µg of the lysate are separated on a 4-12% Bis-Tris NuPage gel (Invitrogen) and proteins on the gel are transferred to a nitrocellulose membrane. Membranes are blocked for one hour with TBS-T containing 5% BSA and

developed with a phospho-specific AKT antibody directed against Thr308 (Cell Signaling, 9275) according to the manufacturer's instructions. Immunoblots are reprobred with an antibody binding to Actin (Abcam, ab20272).

ERK1/2 phosphorylation assay

5 5x10⁵ A431 cells are seeded per well of a 6-well plate the day prior antibody addition in RPMI with 10% FCS (fetal calf serum). The next day, 5 µg/mL of the control or bispecific antibodies are added to the medium and cells are incubated an additional hour. A subset of cells is then stimulated for an additional 15 min with 25 ng/mL HGF (R&D, 294-HGN). Cells are washed once with ice cold PBS
10 containing 1 mM sodium vanadate upon which they are placed on ice and lysed in the cell culture plate with 100 µL lysis buffer (50 mM Tris-Cl pH7.5, 150 mM NaCl, 1% NP40, 0.5% DOC, aprotinine, 0.5 mM PMSF, 1 mM sodium-vanadate). Cell lysates are transferred to eppendorf tubes and lysis allowed to proceed for 30 minutes on ice. Protein concentration is determined using the BCA method
15 (Pierce). 30-50 µg of the lysate are separated on a 4-12% Bis-Tris NuPage gel (Invitrogen) and proteins on the gel are transferred to a nitrocellulose membrane. Membranes are blocked for one hour with TBS-T containing 5% BSA and developed with a phospho-specific Erk1/2 antibody directed against Thr202/Tyr204 (CellSignaling, Nr.9106) according to the manufacturer's
20 instructions. Immunoblots are reprobred with an antibody binding to Actin (Abcam, ab20272).

Cell-Cell Dissemination (scatter assay)

A549 (4000 cells per well) or A431 (8000 cells per well) were seeded the day prior compound treatment in a total volume of 200 µL in 96-well E-Plates (Roche, 05232368001) in RPMI with 0.5 % FCS. Adhesion and cell growth was monitored
25 over night with the Real Time Cell Analyzer machine with sweeps every 15 min monitoring the impedance. The next day, cells were pre-incubated with 5 µL of the respective antibody dilutions in PBS with sweeps every five minutes. After 30 minutes 2,5 µL of a HGF solution yielding a final concentration of 20 ng/mL were
30 added and the experiment was allowed to proceed for further 72 hours. Immediate changes were monitored with sweeps every minute for 180 minutes followed by sweeps every 15 minutes for the remainder of the time.

HUVEC proliferation assay

HUVEC cells (Promocell, C-12200) are seeded in collagen coated 96-wells in
35 0.5% FCS containing EBM-2 medium (Promocell, C-22211). The following day a

dilution series of control or bispecific antibodies is added to the cells. After 30 min of incubation 25 ng/mL HGF (R&D, 294-HGN) is added and cells are incubated for another 72 h after which cellular proliferation in form of ATP-content is determined with the cell titer glow assay (Promega, G7571/2/3) according to the manufacturer's recommendation.

5

Sk-Br3 proliferation assay

a) For proliferation studies 10000 cells per well of a 96-well cell culture plate were seeded in serum reduced medium (RPMI 1640 + 4% FCS). The following day the parental Her2 or c-Met antibody as well as the bispecific antibodies were added and cells were cultivated additional 48 h after which ATP, as indicator of cellular proliferation, was determined with cell titer glow assay (Promega).

10

b) For proliferation studies in the presence of HGF, 10000 cells per well of a 96-well cell culture plate were seeded in serum reduced medium (RPMI 1640 + 4% FCS). The following day the parental Her2 or c-Met antibody as well as the bispecific antibody were added as well as 25 ng/mL HGF (R&D, 294-HGN) and cells were cultivated additional 48 h after which ATP, as indicator of cellular proliferation, was determined with cell titer glow assay (Promega).

15

Flow cytometry assay (FACS)

a) Binding Assay

c-Met and ErbB-2 expressing cells were detached and counted. 1.5×10^5 cells were seeded per well of a conical 96-well plate. Cells were spun down (1500 rpm, 4°C, 5 min) and incubated for 30 min on ice in 50 μ L of a dilution series of the respective bispecific antibody in PBS with 2 % FCS (fetal calf serum). Cells were again spun down and washed once with 200 μ L PBS containing 2 % FCS followed by a second incubation of 30 min with a phycoerythrin-coupled antibody directed against human Fc which was diluted in PBS containing 2 % FCS (Jackson Immunoresearch, 109116098). Cells were spun down washed twice with 200 μ L PBS containing 2 % FCS, resuspended in BD CellFix solution (BD Biosciences) and incubated for at least 10 min on ice. Mean fluorescence intensity (mfi) of the cells was determined by flow cytometry (FACS Canto, BD). Mfi was determined at least in duplicates of two independent stainings. Flow cytometry spectra were further processed using the FlowJo software (TreeStar). Half-maximal binding was determined using XLFit 4.0 (IDBS) and the dose response one site model 205.

20

25

30

b) Internalization Assay

Cells were detached and counted. 5×10^5 cells were placed in 50 μL complete medium in an eppendorf tube and incubated with 5 $\mu\text{g}/\text{mL}$ of the respective bispecific antibody at 37°C . After the indicated time points cells were stored on ice until the time course was completed. Afterwards, cells were transferred to FACS tubes, spun down (1500 rpm, 4°C , 5min), washed with PBS + 2 % FCS and incubated for 30 minutes in 50 μL phycoerythrin-coupled secondary antibody directed against human Fc which was diluted in PBS containing 2 % FCS (Jackson ImmunoResearch, 109116098). Cells were again spun down, washed with PBS + 2 % FCS and fluorescence intensity was determined by flow cytometry (FACS Canto, BD).

Cell Titer Glow Assay

Cell viability and proliferation was quantified using the cell titer glow assay (Promega). The assay was performed according to the manufacturer's instructions. Briefly, cells were cultured in 96-well plates in a total volume of 100 μL for the desired period of time. For the proliferation assay, cells were removed from the incubator and placed at room temperature for 30 min. 100 μL of cell titer glow reagent were added and multi-well plates were placed on an orbital shaker for 2 min. Luminescence was quantified after 15 min on a microplate reader (Tecan).

Wst-1 Assay

A Wst-1 viability and cell proliferation assay was performed as endpoint analysis, detecting the number of metabolic active cells. Briefly, 20 μL of Wst-1 reagent (Roche, 11644807001) were added to 200 μL of culture medium. 96-well plates were further incubated for 30 min to 1 h until robust development of the dye. Staining intensity was quantified on a microplate reader (Tecan) at a wavelength of 450 nm.

Design of bispecific <ErbB2-c-Met> antibodies

All of the following expressed and purified bispecific <ErbB-2-c-Met> antibodies comprise a constant region or at least the Fc part of IgG1 subclass (human constant IgG1 region of SEQ ID NO: 9) which is eventually modified as indicated below.

In Table 1: Trivalent, bispecific <ErbB-2-c-Met> antibodies based on a full length ErbB-2 antibody (trastuzumab) and one single chain Fab fragment (for a basic structure scheme see Fig. 5a) from a c-Met antibody (cMet 5D5) with the respective features shown in Table 1 one were or can be expressed and purified according to

the general methods described above. The corresponding VH and VL of trastuzumab and cMet 5D5 are given in the sequence listing.

Table 1:

Molecule Name	BsAB02
scFab-Ab-nomenclature for bispecific antibodies	
Features:	
Knobs-in-hole mutations	S354C: T366W/ Y349'C: T366'S: L368'A: Y407'V
Full length antibody backbone derived from	trastuzumab
Single chain Fab fragment derived from	cMet 5D5 (humanized)
Position of scFab attached to antibody	C-terminus knob heavy chain
Linker (ScFab)	(G ₄ S) ₅ GG
Peptide connector	(G ₄ S) ₂
ScFab disulfide VH44/ VL100 stabilized	-

5

Example 1:

Binding of bispecific antibodies to ErbB-2 and c-Met

(Surface Plasmon Resonance)

The binding affinity was determined with a standard binding assay at 25°C, such as surface plasmon resonance technique (BIAcore®, GE-Healthcare Uppsala,

Sweden). For affinity measurements, 30 µg/ml of anti Fcγ antibodies (from goat, Jackson Immuno Research) were coupled to the surface of a CM-5 sensor chip by standard amine-coupling and blocking chemistry on a SPR instrument (Biacore T100). After conjugation, mono- or bispecific ErbB2/cMet antibodies were injected at 25°C at a flow rate of 5 µL/min, followed by a dilution series (0 nM to 1000 nM) of human ErbB2 or c-Met ECD at 30 µL/min. As running buffer for the binding experiment PBS/0.1 % BSA was used. The chip was then regenerated with a 60s pulse of 10 mM glycine-HCl, pH 2.0 solution.

Table 2: Binding characteristics of bispecific antibodies binding to ErbB2/cMet as determined by surface plasmon resonance.

binding specificity		BsAB02 [Mol]
c-Met	ka (1/Ms)	8,40E+03
	kd (1/s)	6,60E-05
	KD (M)	8,20E-09
ErbB-2	ka (1/Ms)	9,50E+04
	kd (1/s)	<1E-06
	KD (M)	<1E-10

Example 2:

Inhibition of HGF-induced c-Met receptor phosphorylation by bispecific HER2/c-Met antibody formats.

To confirm functionality of the c-Met part in the bispecific antibodies a c-Met phosphorylation assay is performed. In this experiment A549 lung cancer cells or HT29 colorectal cancer cells are treated with the bispecific antibodies or control antibodies prior exposure to HGF. Cells are then lysed and phosphorylation of the c-Met receptor is examined. Both cell lines can be stimulated with HGF as can be observed by the occurrence of a phopho-c-Met specific band in the immunoblot. Binding of the parental or bispecific antibodies leads to inhibition of receptor phosphorylation. Alternatively, one can also use cells, e.g. U87MG, with an autocrine HGF loop and assess c-Met receptor phosphorylation in the absence or presence of parental or bispecific antibodies.

Example 3:**Analysis of Her2 receptor phosphorylation after treatment with Her2/cMet bispecific antibodies**

5 To confirm functionality of the Her2-binding part in the bispecific Her2/cMet antibodies Sk-Br3 are incubated either with the parental EGFR antibodies or bispecific Her2/cMet antibodies. Binding of the parental or bispecific antibodies but not of an unrelated IgG control antibody leads to inhibition of receptor phosphorylation. Alternatively, one can also use cells which are stimulated with NRG to induce ErbB2/Her2 receptor phosphorylation in the presence or absence of
10 parental or bispecific antibodies.

Example 4:**Analysis of PI3K signaling after treatment with Her2/cMet bispecific antibodies**

15 Her2 as well as c-Met receptor can signal via the PI3K pathway which conveys mitogenic signals. To demonstrate simultaneous targeting of the Her2 and c-Met receptor phosphorylation of AKT, a downstream target in the PI3K pathway, can be monitored. To this End, unstimulated cells, cells treated with NRG or HGF or cells treated with both cytokines are in parallel incubated with unspecific, parental control or bispecific antibodies. Alternatively, one can also assess cells which
20 overexpress ErbB2/Her2 and/or have an autocrine HGF loop which activates c-Met signaling. AKT is a major downstream signaling component of the PI3K pathway and phosphorylation of this protein is a key indicator of signaling via this pathway.

Example 5:**Analysis of MAPK signaling after treatment with Her2/cMet bispecific antibodies**
25

c-Met receptor can signal via the MAPK pathway. To demonstrate targeting of the c-Met receptor, phosphorylation of ERK1/2, a major downstream target in the MAPK pathway, can be monitored. To this End, unstimulated cells or cells treated with HGF are in parallel incubated with unspecific, parental control or bispecific
30 antibodies. Alternatively, one can also assess cells which have an autocrine HGF loop which activates c-Met signaling.

Example 6:**Inhibition of HGF-induced HUVEC proliferation by bispecific Her2/c-Met antibody formats.**

5 HUVEC proliferation assays can be performed to demonstrate the angiogenic and mitogenic effect of HGF. Addition of HGF to HUVEC leads to an increase in cellular proliferation which can be inhibited by c-Met binding antibodies in a dose-dependent manner.

Example 7:**Inhibition of Sk-Br3 proliferation by bispecific Her2/c-Met antibodies.**

10 a) Sk-Br3 cells display high cell surface levels of Her2 and medium high cell surface expression of c-Met as was independently confirmed in flow cytometry. Addition of the parental Her2-binding antibody or the bispecific Her2/c-Met antibody leads to a decrease in proliferation, while the c-Met-binding antibody has only minor effects on proliferation.

15 b) To simulate a situation in which an active Her2 – c-Met-receptor signaling network occurs proliferation assays are conducted as described but in the presence of HGF-conditioned media. In this setting addition of either one of the parental antibodies has only minor effects on cellular proliferation as determined by cell titer glow analysis while addition of the bispecific antibodies or the combination of
20 the parental antibodies leads to a decrease in cellular proliferation.

Example 8:**Analysis of inhibition of HGF-induced cell-cell dissemination (scattering) in the cancer cell line DU145 by bispecific Her2/c-Met antibody formats.**

25 HGF-induced scattering induces morphological changes of the cell, resulting in rounding of the cells, filopodia-like protrusions, spindle-like structures and a certain motility of the cells. A bispecific Her2/cMet antibody suppressed HGF-induced cell cell dissemination.

Example 9:**Inhibition of HGF-induced HUVEC proliferation by bispecific HER2/c-Met antibody formats.**

5 HUVEC proliferation assays can be performed to demonstrate the mitogenic effect of HGF. Addition of HGF to HUVEC leads to a twofold increase in proliferation. Addition of human IgG control antibody in the same concentration range as the bispecific antibodies has no impact on cellular proliferation while the 5D5 Fab fragment inhibits HGF-induced proliferation.

Example10:

10 **Analysis of inhibition of HGF-induced cell-cell dissemination (scattering) in the cancer cell line A431 by bispecific HER2/c-Met antibody.**

15 HGF-induced scattering includes morphological changes of the cell, resulting in rounding of the cells, filopodia-like protrusions, spindle-like structures and a certain motility of the cells. The Real Time Cell Analyzer (Roche) measures the impedance of a given cell culture well and can therefore indirectly monitor changes in cellular morphology and proliferation. Addition of HGF to A431 and A549 cells results in changes of the impedance which can be monitored as function of time.

Example 11:

20 **Analysis of antibody-mediated receptor internalization in ErbB-2 and c-Met expressing cancer cell lines**

25 Incubation of cells with antibodies specifically binding to Her2 or c-Met has been shown to trigger internalization of the receptor. In order to assess the internalization capability of the bispecific antibodies, an experimental setup is designed to study antibody-induced receptor internalization. For this purpose, OVCAR-8 cells ((NCI Cell Line designation; purchased from NCI (National Cancer Institute) OVCAR-8-NCI; Schilder RJ, et al Int J Cancer. 1990 Mar 15;45(3):416-22; Ikediobi ON, et al, Mol Cancer Ther. 2006;5;2606-12; Lorenzi, P.L., et al Mol Cancer Ther 2009; 8(4):713-24)) (which express Her2 as well as c-Metas was confirmed by flow cytometry -see Figure 7b) were incubated for 30 different periods of time (e.g 0, 30, 60, 120 minutes = 0, 0.5, 1, 2 hours (h)) with the respective primary antibody at 37°C. Cellular processes are stopped by rapidly cooling the cells to 4°C. A secondary fluorophor-coupled antibody specifically binding to the Fc of the primary antibody was used to detect antibodies bound to

the cell surface. Internalization of the antibody-receptor complex depletes the antibody-receptor complexes on the cell surface and results in decreased mean fluorescence intensity. Internalization was studied in OvcAR-8 cells. Results are shown in the following table and Figure 8. % Internalization of the respective receptor is measured via the internalization of the respective antibodies (In Figure 8, the bispecific <ErbB2-cMet> antibody BsAB02 is designated as cMet/HER2, the parent monospecific, bivalent antibodies are designated as <HER2> and <cMet>.)

Table : % Internalization of c-Met receptor by bispecific Her2/ cMet antibody as compared to parent monospecific, bivalent c-Met and HER2 antibody measured with FACS assay after 1 hours on OVCAR-8 cells. Measurement % of c-Met receptor on cell surface at 0h (= in the absence of antibody) is set as 100 % of c-Met receptor on cell surface.

Antibody	% c-Met receptor on OVCAR-8 cell surface measured after 1 hour	% Internalization of c-Met after 1 hour on OVCAR-8 cells (ATCC No. CRL-1555) (= 100- % antibody on cell surface)
A) Monospecific <c-Met> parent antibody		
Mab 5D5	67	33
B) Bispecific <ErbB2-cMet > antibodies		
BsAB02	107	-7

Example 12:

15 Preparation of glycoengineered versions of bispecific Her2/c-Met antibodies

The DNA sequences of bispecific Her2/c-Met antibody are subcloned into mammalian expression vectors under the control of the MPSV promoter and upstream of a synthetic polyA site, each vector carrying an EBV OriP sequence.

Bispecific antibodies are produced by co-transfecting HEK293-EBNA cells with the mammalian bispecific antibody expression vectors using a calcium phosphate-transfection approach. Exponentially growing HEK293-EBNA cells are transfected by the calcium phosphate method. For the production of the glycoengineered antibody, the cells are co-transfected with two additional plasmids, one for a fusion

- 66 -

GnTIII polypeptide expression (a GnT-III expression vector), and one for mannosidase II expression (a Golgi mannosidase II expression vector) at a ratio of 4:4:1:1, respectively. Cells are grown as adherent monolayer cultures in T flasks using DMEM culture medium supplemented with 10% FCS, and are transfected when they are between 50 and 80% confluent. For the transfection of a T150 flask, 15 million cells are seeded 24 hours before transfection in 25 ml DMEM culture medium supplemented with FCS (at 10% V/V final), and cells are placed at 37°C in an incubator with a 5% CO₂ atmosphere overnight. For each T150 flask to be transfected, a solution of DNA, CaCl₂ and water is prepared by mixing 94 µg total plasmid vector DNA divided equally between the light and heavy chain expression vectors, water to a final volume of 469 µl and 469 µl of a 1M CaCl₂ solution. To this solution, 938 µl of a 50 mM HEPES, 280 mM NaCl, 1.5 mM Na₂HPO₄ solution at pH 7.05 are added, mixed immediately for 10 sec and left to stand at room temperature for 20 sec. The suspension is diluted with 10 ml of DMEM supplemented with 2% FCS, and added to the T150 in place of the existing medium. Then additional 13 ml of transfection medium are added. The cells are incubated at 37°C, 5% CO₂ for about 17 to 20 hours, then medium is replaced with 25 ml DMEM, 10% FCS. The conditioned culture medium is harvested 7 days post-transfection by centrifugation for 15 min at 210 x g, the solution is sterile filtered (0.22 µm filter) and sodium azide in a final concentration of 0.01 % w/v is added, and kept at 4°C.

The secreted bispecific afocusylated glycoengineered antibodies are purified by Protein A affinity chromatography, followed by cation exchange chromatography and a final size exclusion chromatographic step on a Superdex 200 column (Amersham Pharmacia) exchanging the buffer to 25 mM potassium phosphate, 125 mM sodium chloride, 100 mM glycine solution of pH 6.7 and collecting the pure monomeric IgG1 antibodies. Antibody concentration is estimated using a spectrophotometer from the absorbance at 280 nm.

The oligosaccharides attached to the Fc region of the antibodies are analysed by MALDI/TOF-MS as described. Oligosaccharides are enzymatically released from the antibodies by PNGaseF digestion, with the antibodies being either immobilized on a PVDF membrane or in solution. The resulting digest solution containing the released oligosaccharides is either prepared directly for MALDI/TOF-MS analysis or further digested with EndoH glycosidase prior to sample preparation for MALDI/TOF-MS analysis.

Example 13:**Analysis of glycostructure of bispecific Her2/c-Met antibodies**

For determination of the relative ratios of fucose- and non-fucose (a-fucose) containing oligosaccharide structures, released glycans of purified antibody material are analyzed by MALDI-Tof-mass spectrometry. For this, the antibody sample (about 50µg) is incubated over night at 37°C with 5mU N-Glycosidase F (Prozyme# GKE-5010B) in 0.1M sodium phosphate buffer, pH 6.0, in order to release the oligosaccharide from the protein backbone. Subsequently, the glycan structures released are isolated and desalted using NuTip-Carbon pipet tips (obtained from Glygen: NuTip1-10 µl, Cat.Nr#NT1CAR). As a first step, the NuTip-Carbon pipet tips are prepared for binding of the oligosaccharides by washing them with 3 µL 1M NaOH followed by 20 µL pure water (e.g. HPLC-gradient grade from Baker, # 4218), 3 µL 30% v/v acetic acid and again 20 µl pure water. For this, the respective solutions are loaded onto the top of the chromatography material in the NuTip-Carbon pipet tip and pressed through it. Afterwards, the glycan structures corresponding to 10 µg antibody are bound to the material in the NuTip-Carbon pipet tips by pulling up and down the N-Glycosidase F digest described above four to five times. The glycans bound to the material in the NuTip-Carbon pipet tip are washed with 20 µL pure water in the way as described above and are eluted stepwise with 0.5 µL 10% and 2.0 µL 20 % acetonitrile, respectively. For this step, the elution solutions are filled in a 0.5 mL reaction vials and are pulled up and down four to five times each. For the analysis by MALDI-Tof mass spectrometry, both eluates are combined. For this measurement, 0.4 µL of the combined eluates are mixed on the MALDI target with 1.6 µL SDHB matrix solution (2.5-Dihydroxybenzoic acid/2-Hydroxy-5-Methoxybenzoic acid [Bruker Daltonics #209813] dissolved in 20 % ethanol/5mM NaCl at 5 mg/ml) and analysed with a suitably tuned Bruker Ultraflex TOF/TOF instrument. Routinely, 50-300 shots are recorded and summed up to a single experiment. The spectra obtained are evaluated by the flex analysis software (Bruker Daltonics) and masses are determined for the each of the peaks detected. Subsequently, the peaks are assigned to fucose or a-fucose (non-fucose) containing glycol structures by comparing the masses calculated and the masses theoretically expected for the respective structures (e.g. complex, hybride and oligo-or high-mannose, respectively, with and without fucose).

For determination of the ratio of hybride structures, the antibody sample are digested with N-Glycosidase F and Endo-Glycosidase H concomitantly. N-glycosidase F releases all N-linked glycan structures (complex, hybride and oligo- and high mannose structures) from the protein backbone and the Endo-Glycosidase H cleaves all the hybride type glycans additionally between the two GlcNAc-residue at the reducing end of the glycan. This digest is subsequently treated and analysed by MALDI-Tof mass spectrometry in the same way as described above for the N-Glycosidase F digested sample. By comparing the pattern from the N-Glycosidase F digest and the combined N-glycosidase F / Endo H digest, the degree of reduction of the signals of a specific glyco structure is used to estimate the relative content of hybride structures.

The relative amount of each glycostructure is calculated from the ratio of the peak height of an individual glycol structure and the sum of the peak heights of all glyco structures detected. The amount of fucose is the percentage of fucose-containing structures related to all glyco structures identified in the N-Glycosidase F treated sample (e.g. complex, hybride and oligo- and high-mannose structures, resp.). The amount of afucosylation is the percentage of fucose-lacking structures related to all glyco structures identified in the N-Glycosidase F treated sample (e.g. complex, hybride and oligo- and high-mannose structures, resp.).

20 **Example 14:**

Analysis of cellular migration after treatment with Her2/cMet bispecific antibodies

One important aspect of active c-Met signaling is induction of a migratory and invasive programme. Efficacy of a c-Met inhibitory antibody can be determined by measuring the inhibition of HGF-induced cellular migration. For this purpose, the HGF-inducible cancer cell line A431 is treated with HGF in the absence or presence of bispecific antibody or an IgG control antibody and the number of cells migrating through an 8 μm pore is measured in a time-dependent manner on an Acea Real Time cell analyzer using CIM-plates with an impedance readout.

30 **Example 15:**

In vitro ADCC of bispecific Her2/c-Met antibodies

The Her2/cMet bispecific antibodies according to the invention display reduced internalization on cells expressing both receptors. Reduced internalization strongly

supports the rationale for glycoengineering these antibodies as a prolonged exposure of the antibody-receptor complex on the cell surface is more likely to be recognized by Nk cells. Reduced internalization and glycoengineering translate into enhanced antibody dependent cell cytotoxicity (ADCC) in comparison to the parental antibodies. An in vitro experimental setup to demonstrate these effects can be designed using cancer cells which express both Her2 and cMet, on the cell surface, e.g. A431, and effector cells like a Nk cell line or PBMC's. Tumor cells are pre-incubated with the parent monospecific antibodies or the bispecific antibodies for up to 24 h followed by the addition of the effector cell line. Cell lysis is quantified and allows discrimination of mono- and bispecific antibodies.

The target cells, e.g. PC-3 (DSMZ #ACC 465, prostatic adenocarcinoma, cultivation in Ham's F12 Nutrient Mixture + 2 mM L-alanyl-L-Glutamine + 10 % FCS) are collected with trypsin/EDTA (Gibco # 25300-054) in exponential growth phase. After a washing step and checking cell number and viability the aliquot needed is labeled for 30 min at 37°C in the cell incubator with calcein (Invitrogen #C3100MP; 1 vial was resuspended in 50 µl DMSO for 5 Mio cells in 5 ml medium). Afterwards, the cells are washed three times with AIM-V medium, the cell number and viability is checked and the cell number adjusted to 0.3 Mio/ml.

Meanwhile, PBMC as effector cells are prepared by density gradient centrifugation (Histopaque-1077, Sigma # H8889) according to the manufacturer's protocol (washing steps 1x at 400g and 2x at 350g 10 min each). The cell number and viability is checked and the cell number adjusted to 15 Mio/ml.

100µl calcein-stained target cells are plated in round-bottom 96-well plates, 50µl diluted antibody is added and 50µl effector cells. In some experiments the target cells are mixed with Redimune ® NF Liquid (ZLB Behring) at a concentration of 10 mg/ml Redimune.

As controls serves the spontaneous lysis, determined by co-culturing target and effector cells without antibody and the maximal lysis, determined by 1 % Triton X-100 lysis of target cells only. The plate is incubated for 4 hours at 37°C in a humidified cell incubator.

The killing of target cells is assessed by measuring LDH release from damaged cells using the Cytotoxicity Detection kit (LDH Detection Kit, Roche # 1 644 793) according to the manufacturer's instruction. Briefly, 100 µl supernatant from each

well is mixed with 100 µl substrate from the kit in a transparent flat bottom 96 well plate. The Vmax values of the substrate's colour reaction is determined in an ELISA reader at 490 nm for at least 10 min. Percentage of specific antibody-mediated killing is calculated as follows: $((A - SR)/(MR - SR) \times 100$, where A is the mean of Vmax at a specific antibody concentration, SR is the mean of Vmax of the spontaneous release and MR is the mean of Vmax of the maximal release.

Example 16

In vivo efficacy of bispecific Her2 / cMet antibodies in a subcutaneous xenograft model with a paracrine HGF loop

A subcutaneous KPL4 model, coinjected with Mrc-5 cells, mimicks a paracrine activation loop for c-Met. KPL4 express to a certain amount c-Met as well as Her2 on the cell surface. KPL4 and Mrc-5 cells are maintained under standard cell culture conditions in the logarithmic growth phase. KPL4 and Mrc-5 cells are injected in a 10:1 ratio with ten million KPL4 cells and one million Mrc-5. Cells are engrafted to SCID beige mice. Treatment starts after tumors are established and have reached a size of 100-150 mm³. Mice are treated with a loading dose of 20 mg/kg of antibody / mouse and then once weekly with 10 mg/kg of antibody / mouse. Tumor volume is measured twice a week and animal weights are monitored in parallel. Single treatments and combination of the single antibodies are compared to the therapy with bispecific antibody.

Example 17

Inhibition of OVCAR-8 proliferation by bispecific Her1/c-Met antibodies.

a) OVCAR-8 cells ((NCI Cell Line designation; purchased from NCI (National Cancer Institute) OVCAR-8-NCI; Schilder RJ, et al Int J Cancer. 1990 Mar 15;45(3):416-22; Ikediobi ON, et al, Mol Cancer Ther. 2006;5;2606-12; Lorenzi, P.L., et al Mol Cancer Ther 2009; 8(4):713-24)) display significant cell surface levels of Her2 and of c-Met as was independently confirmed in flow cytometry (see Figure 7b). Inhibition of OVCAR-8 cell proliferation by bispecific Her2/c-Met antibodies was measured in CellTiterGlowTM assay after 48 hours. Results are shown in Figure 9a. Control was PBS buffer (Phosphate buffered saline).

The measurement showed an inhibition of the HER2 antibody trastuzumab of 6% inhibition (compared to buffer control which is set 0% inhibition). The bispecific Her2/c-Met BsAB02 (BsAb) antibody led to a more pronounced inhibition of

- cancer cell proliferation (11% inhibition). The monovalent c-Met antibody one-armed 5D5 (OA5D5) showed no effect on proliferation. The combination of the HER2 antibody trastuzumab and the monovalent c-Met antibody one-armed 5D5 (OA5D5) led to a less pronounced decrease(6% inhibition)
- 5 b) OVCAR-8 cells are dependent on HER2 signaling. To simulate a situation in which an active HER – c-Met-receptor signaling network occurs further proliferation assays were conducted as described under a) (CellTiterGlow™ assay after 48 hours) but in the presence of HGF-conditioned media. Results are shown in Figure 9b.
- 10 The measurement showed almost no inhibition effect of the Her2 antibody trastuzumab (2% inhibition) and of the monovalent c-Met antibody one-armed 5D5 (OA5D5) (3% inhibition) if compared to HGF-treated cells which were set to 0% inhibition. The bispecific Her2/c-Met antibody BsAB02 (BsAb) (17% inhibition) showed a pronounced inhibition of the cancer cell proliferation of OvcAR-8 cells.
- 15 The combination of the Her2 antibody trastuzumab and the monovalent c-Met antibody one-armed 5D5 (OA5D5) led to a less pronounced decrease in cell proliferation (10% inhibition).

Patent Claims

1. A bispecific antibody specifically binding to human ErbB-2 and human c-Met comprising a first antigen-binding site that specifically binds to human ErbB-2 and a second antigen-binding site that specifically binds to human c-Met, characterized in that said bispecific antibody shows an internalization of c-Met of no more than 15 % when measured after 1 hour in a flow cytometry assay on OVCAR-8 cells, as compared to internalization of c-Met in the absence of said bispecific antibody.
2. The bispecific antibody according to claim 1 characterized in being a bivalent or trivalent, comprising one or two antigen-binding sites that specifically bind to human ErbB-2 and a third antigen-binding site that specifically binds to human c-Met.
3. The antibody according to claim 2 characterized in comprising
 - a) a full length antibody specifically binding to ErbB-2, and consisting of two antibody heavy chains and two antibody light chains; and
 - b) one single chain Fab fragment specifically binding to human c-Met,wherein said single chain Fab fragment under b) is fused to said full length antibody under a) via a peptide connector at the C- or N- terminus of the heavy or light chain of said full length antibody.
4. A bispecific antibody specifically binding to human ErbB-2 and human c-Met comprising a first antigen-binding site that specifically binds to human ErbB-2 and a second antigen-binding site that specifically binds to human c-Met, characterized in that
 - said first antigen-binding site comprises in the heavy chain variable domain a CDR3H region of SEQ ID NO: 15, a CDR2H region of SEQ ID NO: 16, and a CDR1H region of SEQ ID NO:17, and in the light chain variable domain a CDR3L region of SEQ ID NO: 18, a CDR2L region of SEQ ID NO:19, and a CDR1L region of SEQ ID NO:20; and
 - said second antigen-binding site comprises in the heavy chain variable domain a CDR3H region of SEQ ID NO: 21, a CDR2H region of, SEQ ID NO: 22, and a CDR1H region of SEQ ID NO: 23, and in the light chain

variable domain a CDR3L region of SEQ ID NO: 24, a CDR2L region of SEQ ID NO: 25, and a CDR1L region of SEQ ID NO: 26.

5. The bispecific antibody according to claim 4 characterized in that
5 said first antigen-binding site specifically binding to ErbB-2 comprises as heavy chain variable domain the sequence of SEQ ID NO: 1 , and as light chain variable domain the sequence of SEQ ID NO: 2 ; and said second antigen-binding site specifically binding to c-Met comprises as heavy chain variable domain the sequence of SEQ ID NO: 3, and as light chain variable domain the sequence of SEQ ID NO: 4.
- 10 6. The bispecific antibody according to claim 1 to 5, characterized in comprising a constant region of IgG1 or IgG3 subclass.
7. The bispecific antibody according to claim 1 to 6, characterized in that said antibody is glycosylated with a sugar chain at Asn297 whereby the amount of fucose within said sugar chain is 65 % or lower.
- 15 8. A nucleic acid encoding a bispecific antibody according to claim 1 to 7.
9. A pharmaceutical composition comprising a bispecific antibody according to claims 1 to 7.
10. A pharmaceutical composition according to claims 9 for the treatment of cancer.
- 20 11. A bispecific antibody according to claims 1 to 7 for the treatment of cancer.
12. Use of a bispecific antibody according to claims 1 to 7 for the manufacture of a medicament for the treatment of cancer.
13. A method of treatment of patient suffering from cancer by administering a bispecific antibody according to claims 1 to 7 to a patient in the need of such
25 treatment.

Fig. 1

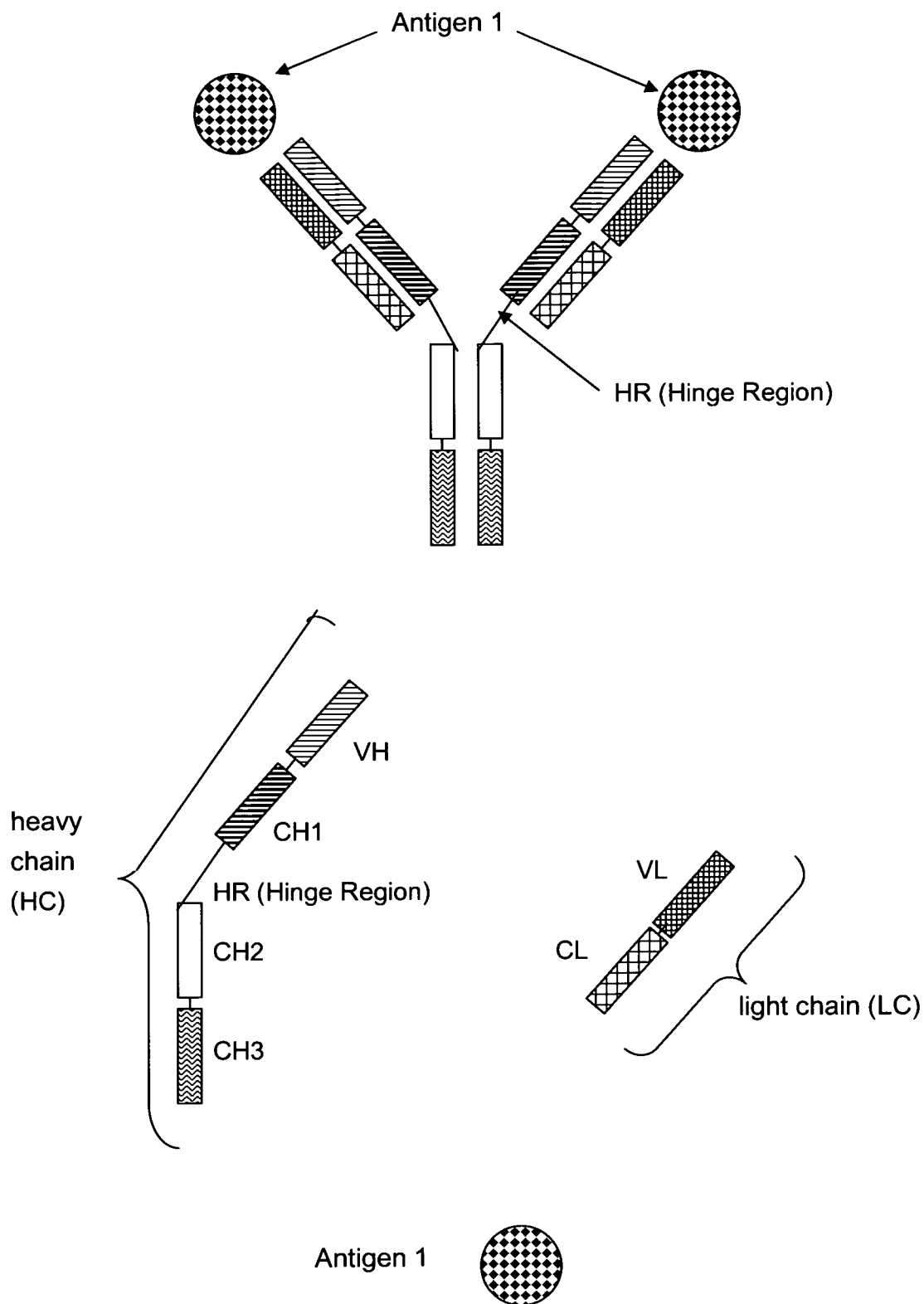

Fig. 2a

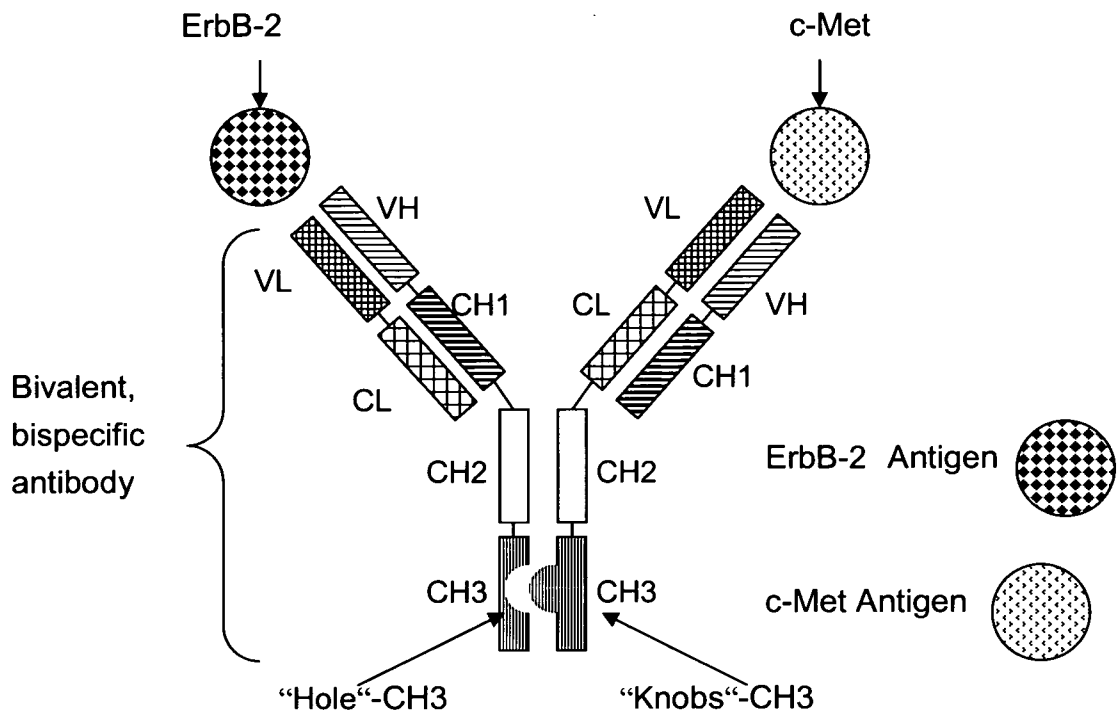

Fig. 2b

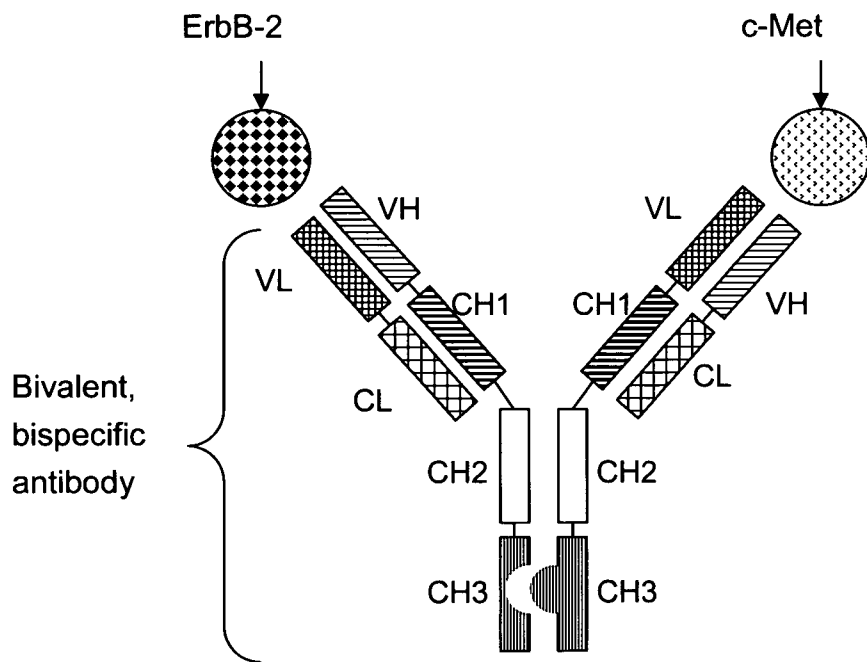

Fig. 2c

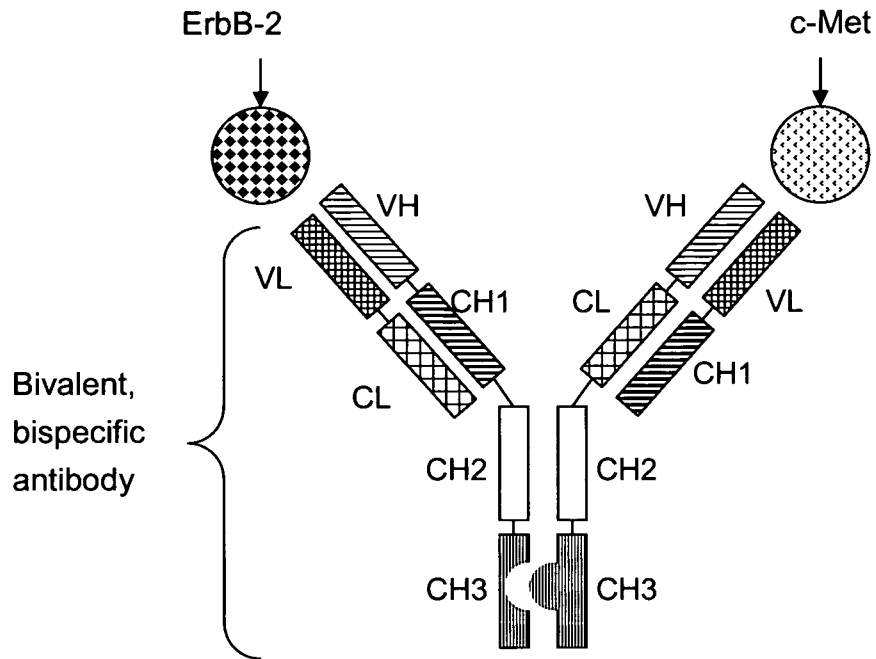

Fig. 3a

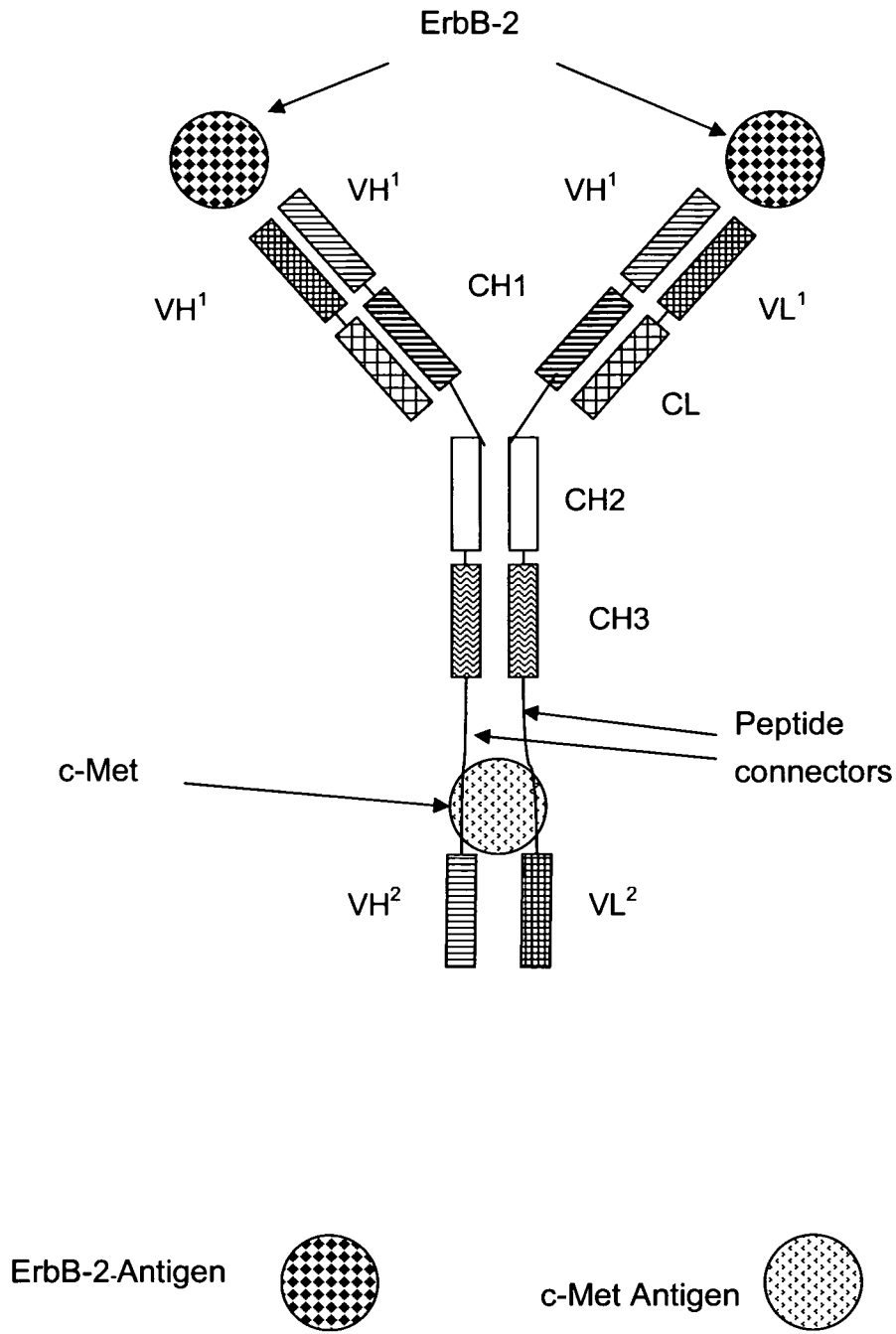

Fig. 3b

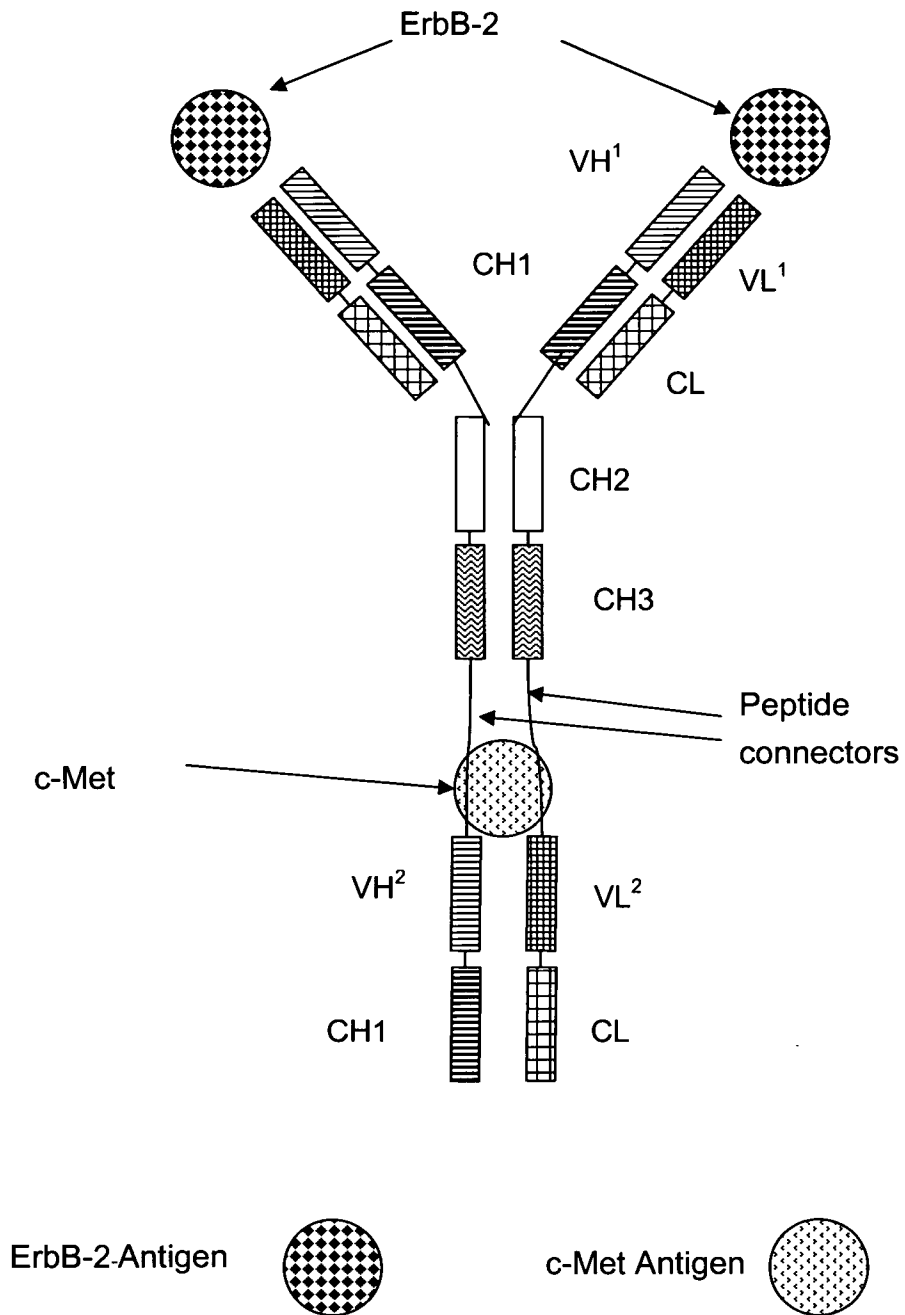

Fig. 3c

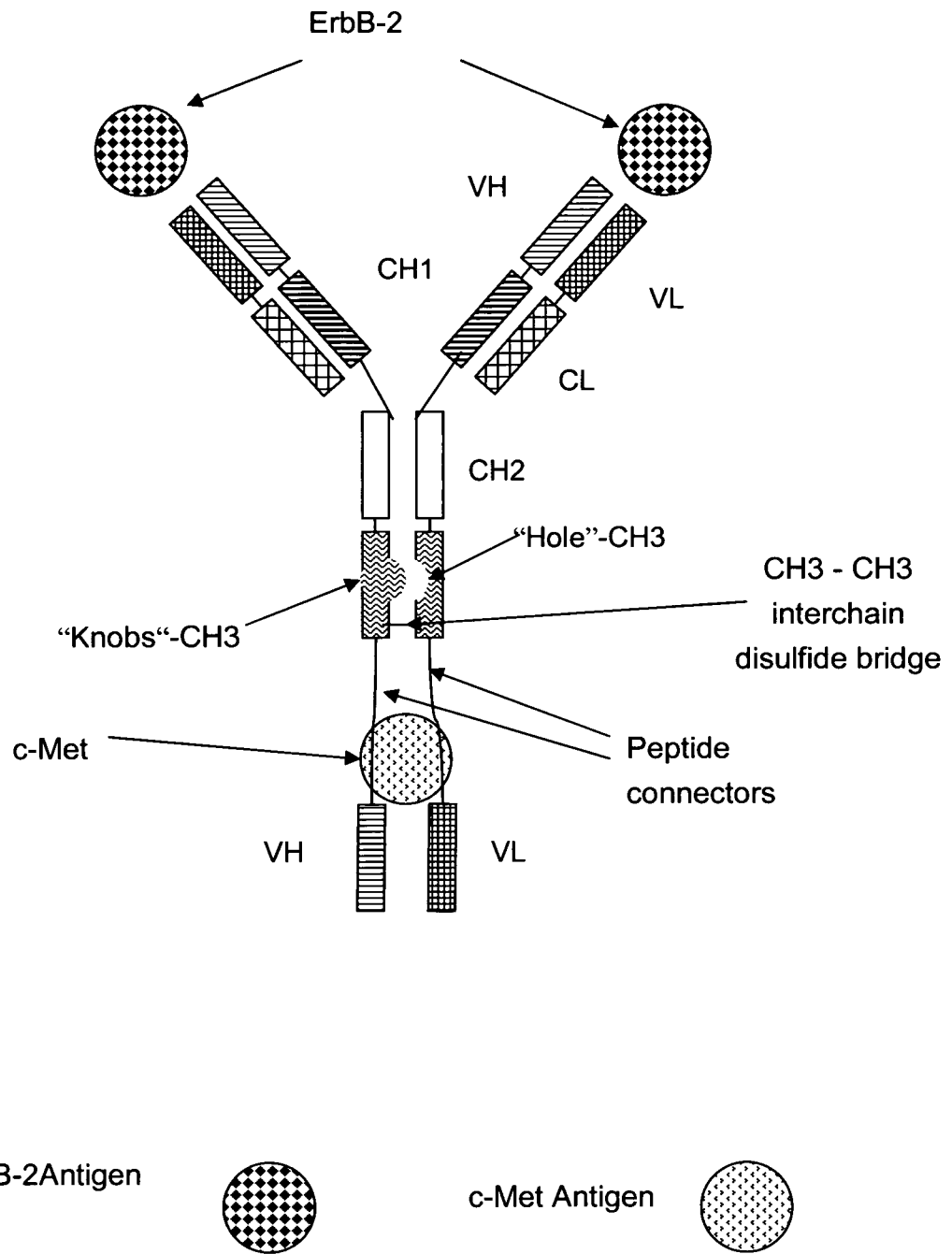

Fig. 3d

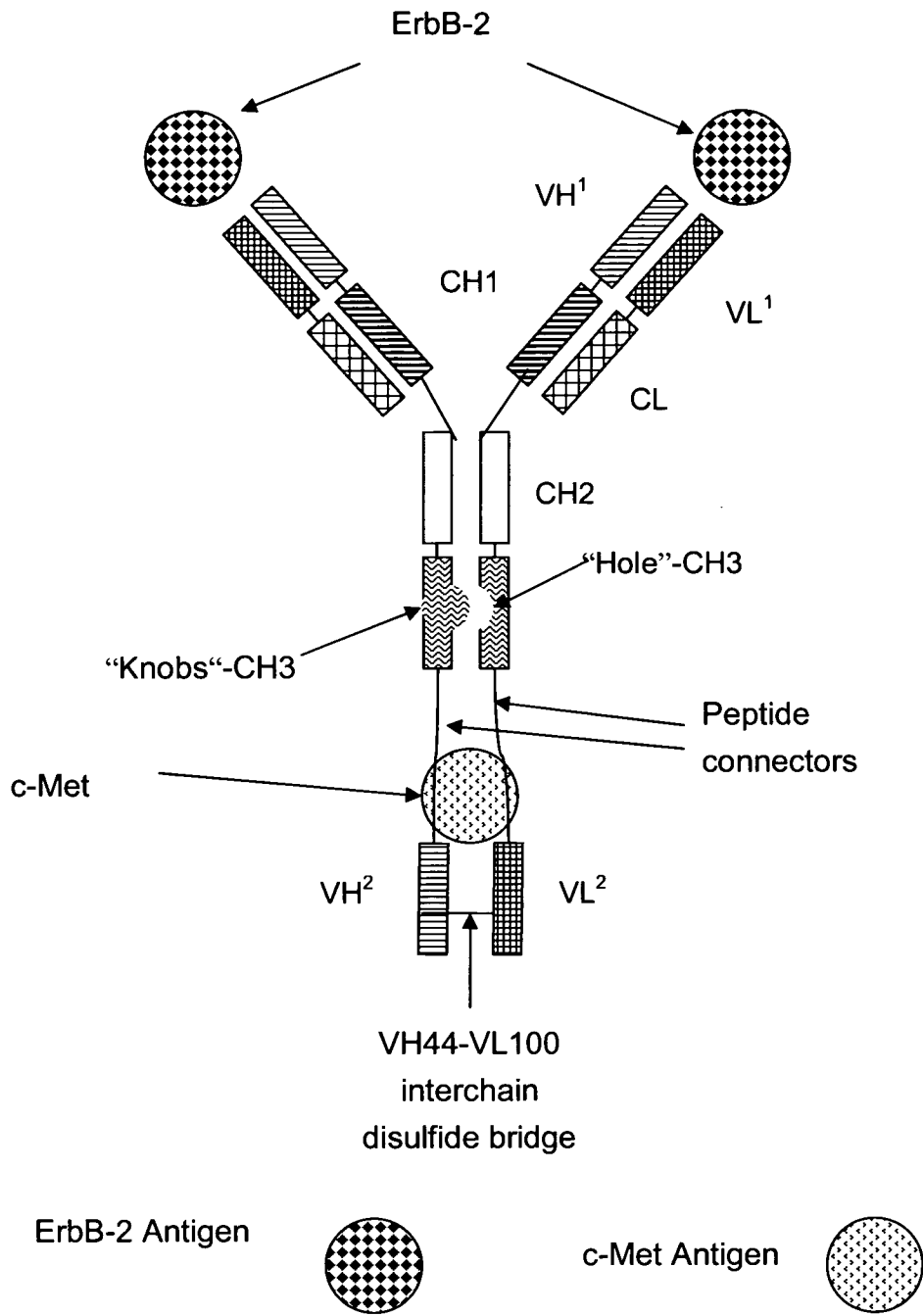

Fig. 4a

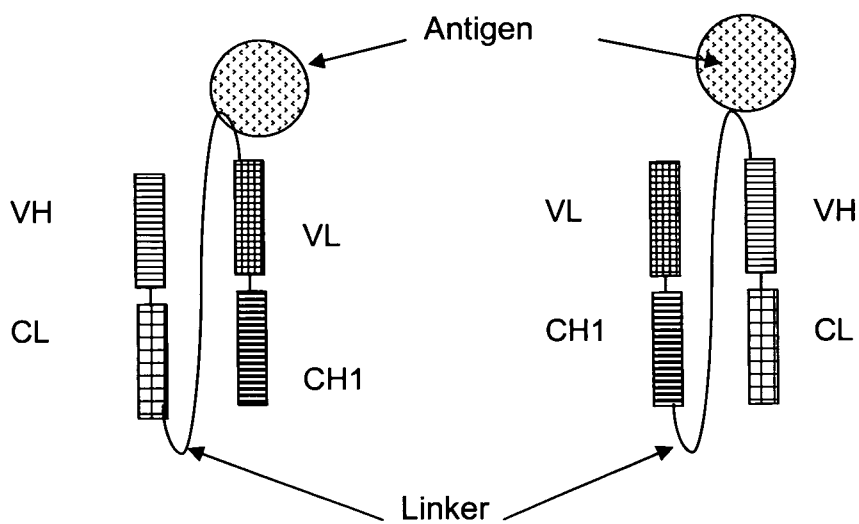
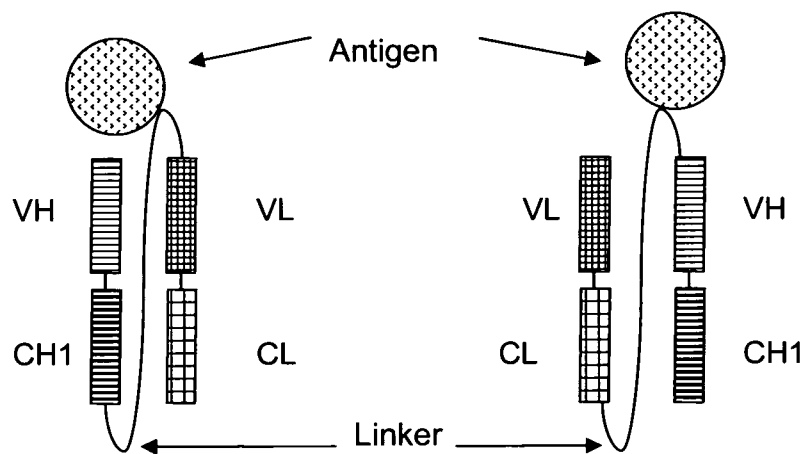

Fig. 4b

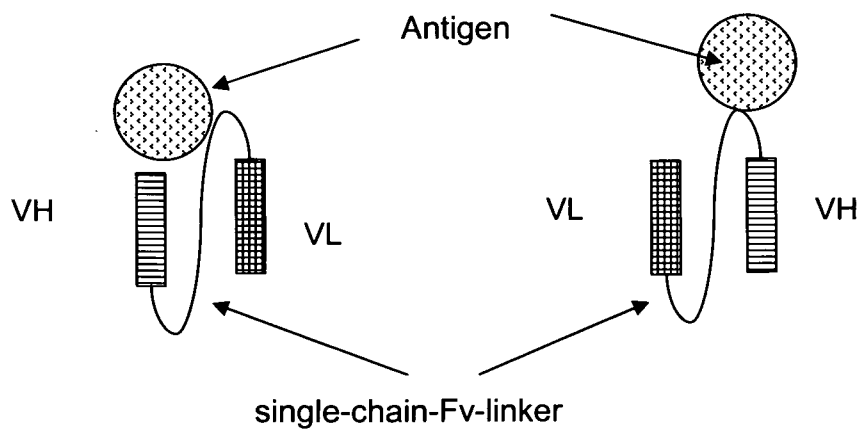

Fig. 5a

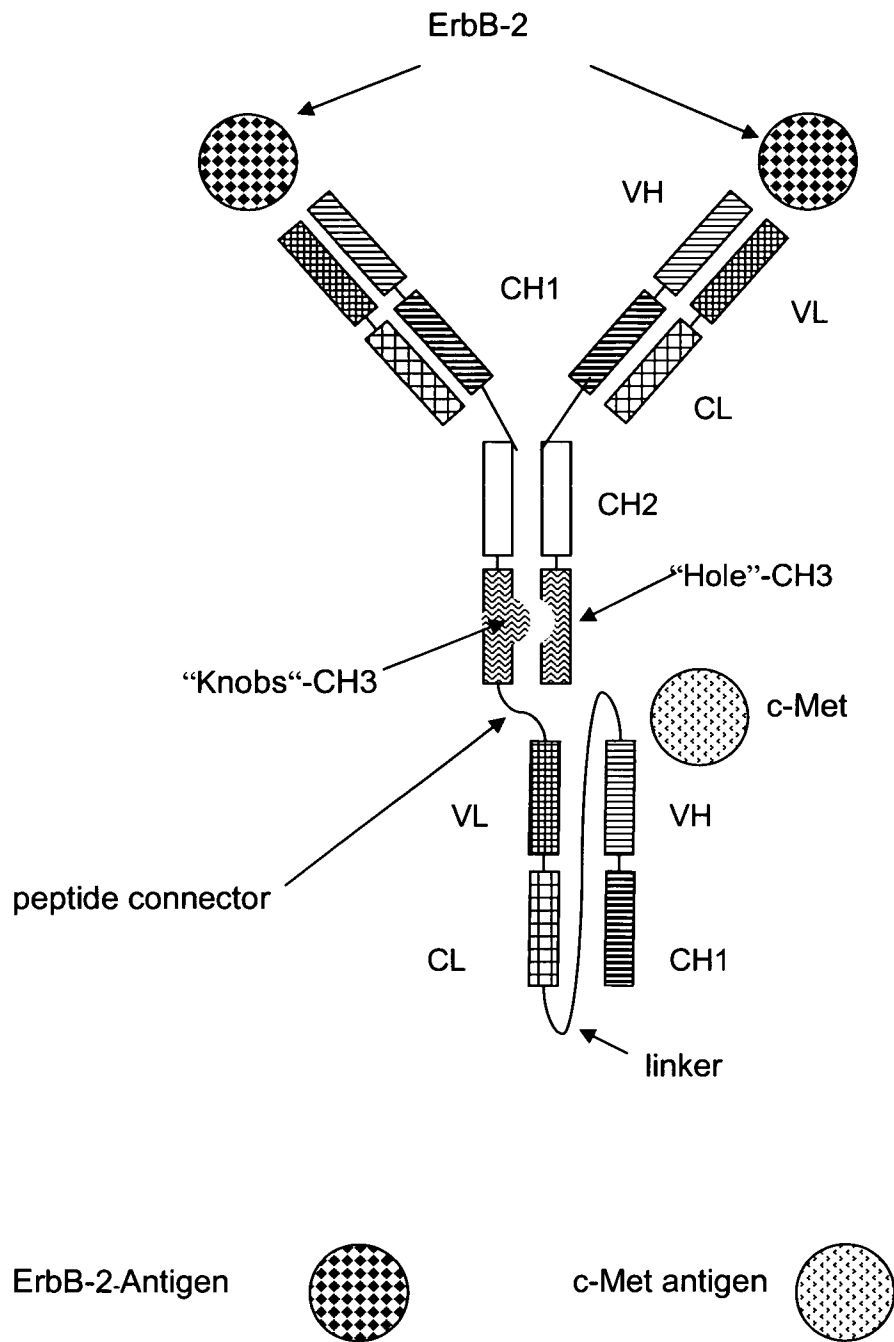

Fig. 5b

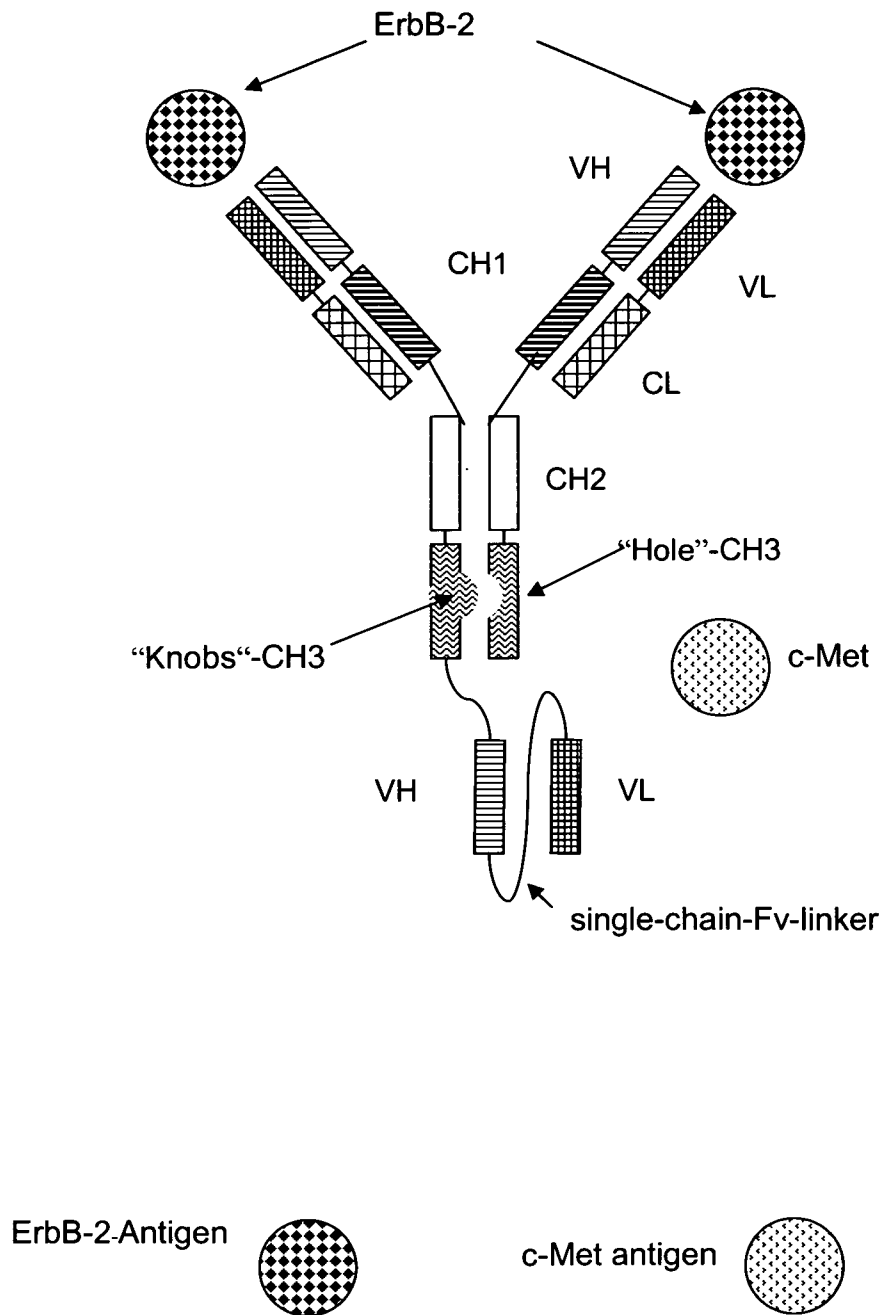

Fig. 6a

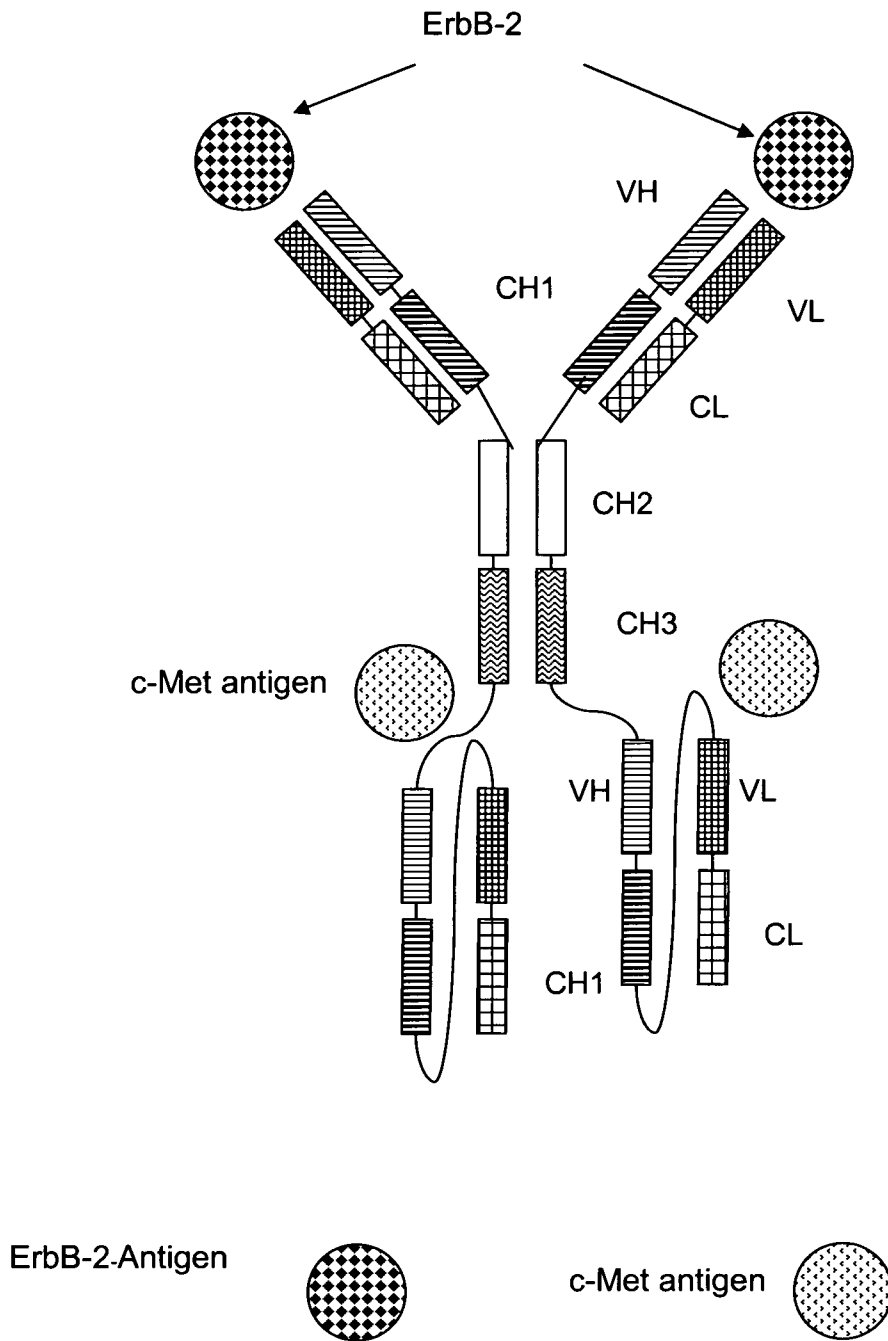

Fig. 6b

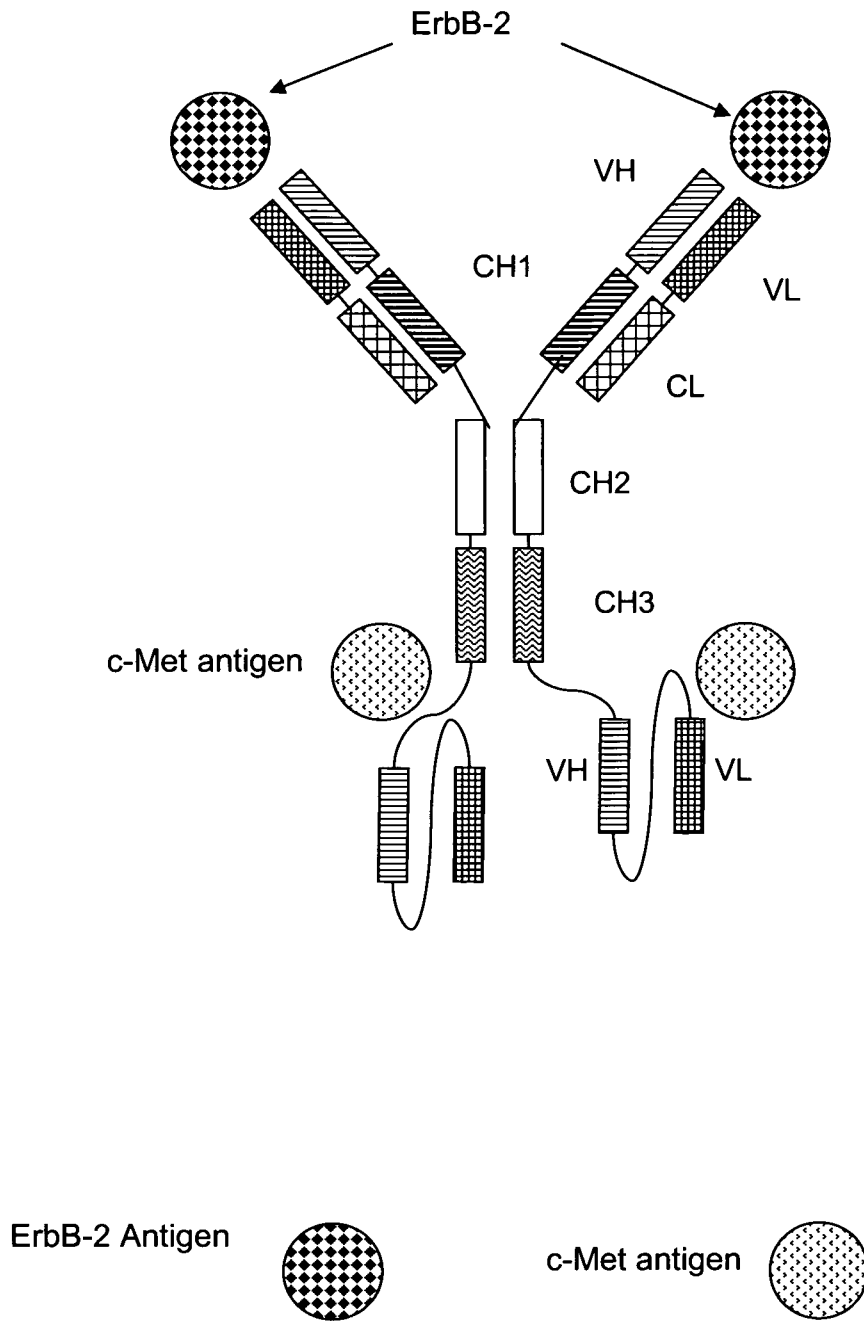

Fig. 7a

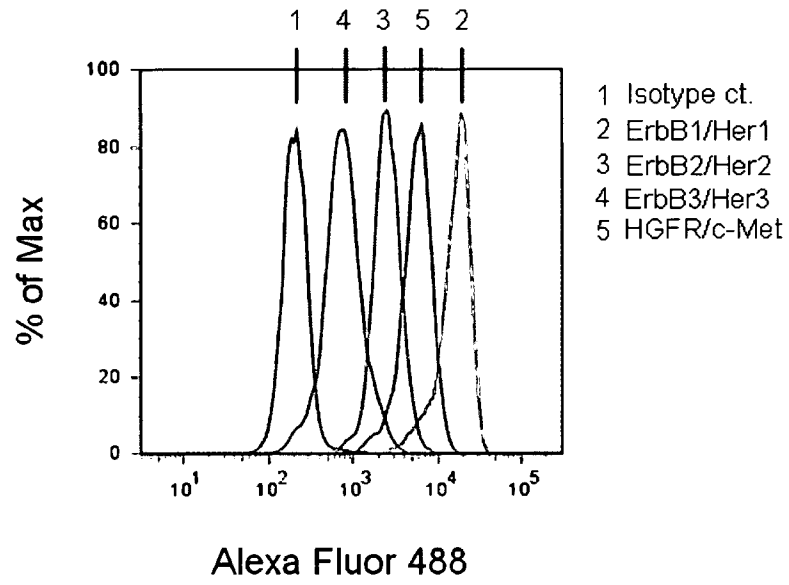

Fig. 7b

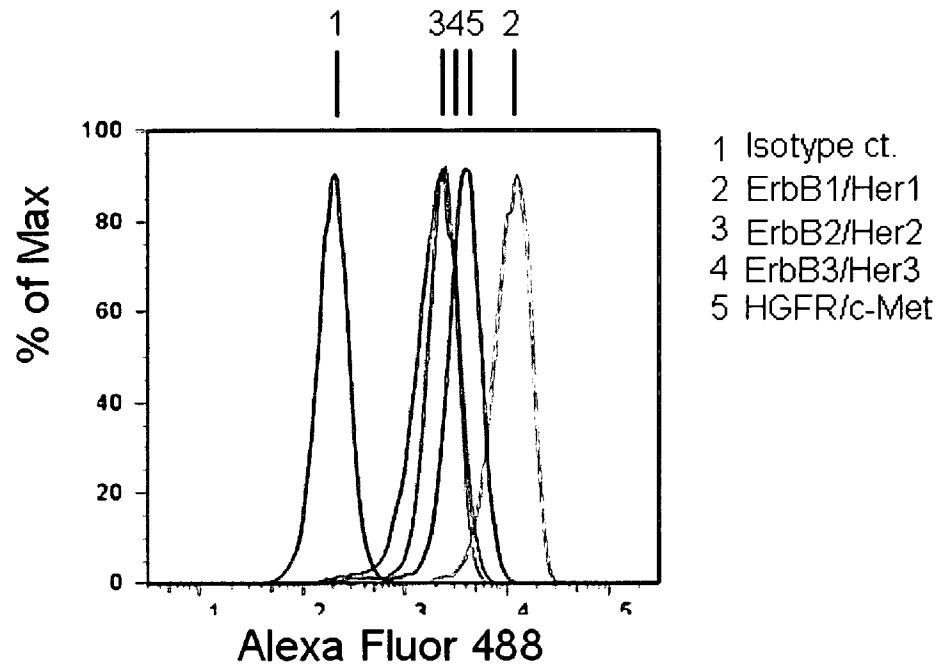

Fig. 8

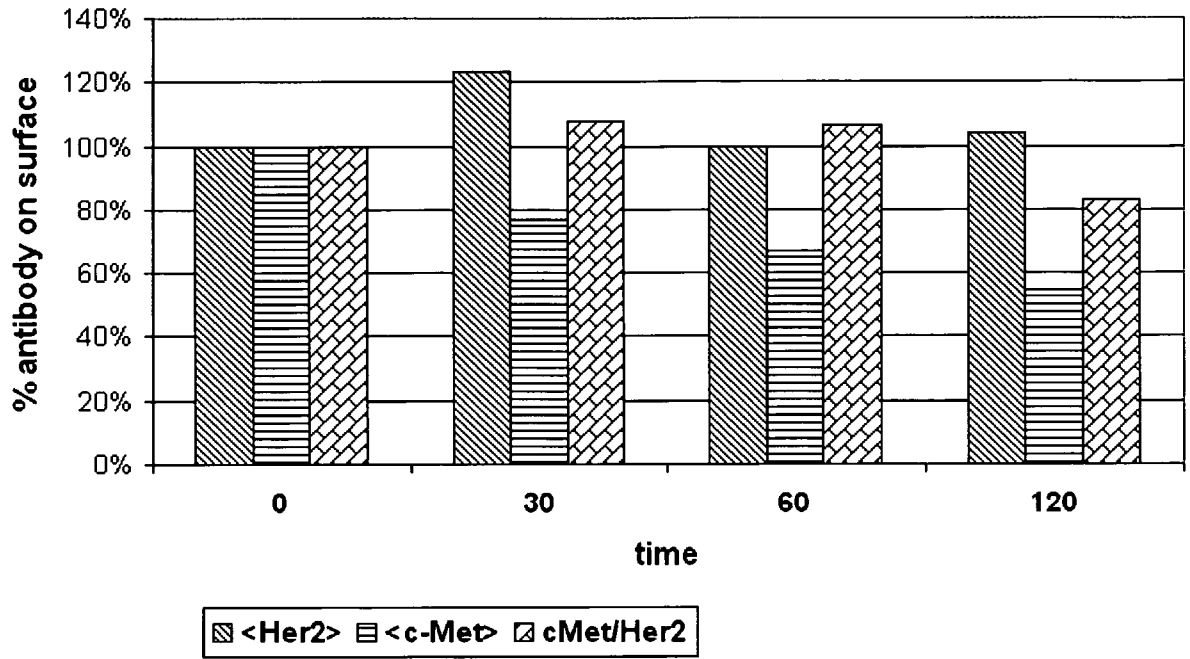

Fig. 9a

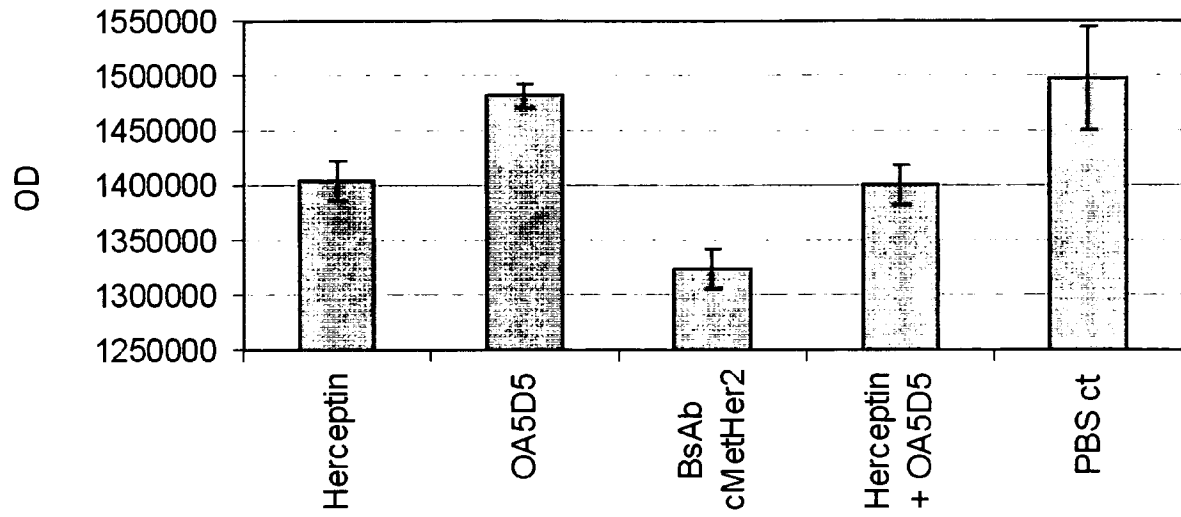
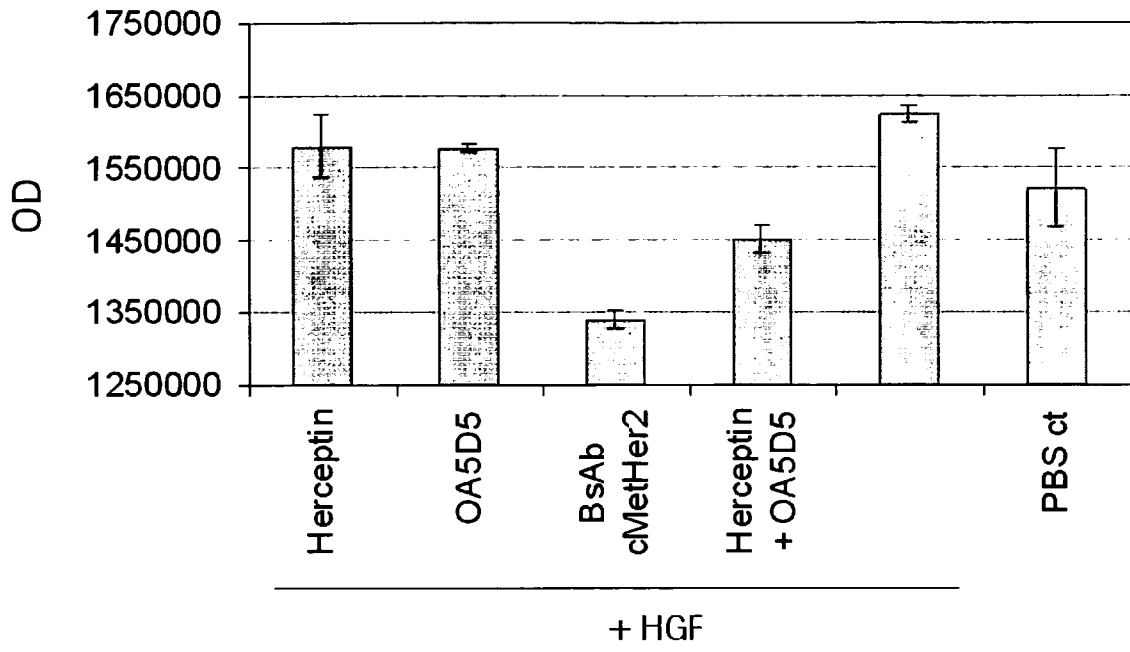

Fig. 9b



INTERNATIONAL SEARCH REPORT

International application No
PCT/EP2010/002006

A. CLASSIFICATION OF SUBJECT MATTER INV. C07K16/32 ADD.		
According to International Patent Classification (IPC) or to both national classification and IPC		
B. FIELDS SEARCHED		
Minimum documentation searched (classification system followed by classification symbols) C07K		
Documentation searched other than minimum documentation to the extent that such documents are included in the fields searched		
Electronic data base consulted during the international search (name of data base and, where practical, search terms used) EPO-Internal		
C. DOCUMENTS CONSIDERED TO BE RELEVANT		
Category*	Citation of document, with indication, where appropriate, of the relevant passages	Relevant to claim No.
A	WO 2008/100624 A2 (MERRIMACK PHARMACEUTICALS INC [US]; SCHOEBERL BIRGIT [US]; NIELSEN ULR) 21 August 2008 (2008-08-21) page 15, line 5 - line 7	1-13
A	WO 2006/104911 A2 (GENENTECH INC [US]; KONG-BELTRAN MONICA [US]; WICKRAMASINGHE DINELI M) 5 October 2006 (2006-10-05) sequences 18, 19	1-13
A,P	WO 2009/134776 A2 (ABBOTT LAB [US]; GHAYUR TARIQ [US]; MORGAN-LAPPE SUSAN E [US]; REILLY) 5 November 2009 (2009-11-05) examples 2.28, 2.52 tables 60, 84	1-13
<input type="checkbox"/> Further documents are listed in the continuation of Box C.		
<input checked="" type="checkbox"/> See patent family annex.		
* Special categories of cited documents :		
"A" document defining the general state of the art which is not considered to be of particular relevance "E" earlier document but published on or after the international filing date "L" document which may throw doubts on priority claim(s) or which is cited to establish the publication date of another citation or other special reason (as specified) "O" document referring to an oral disclosure, use, exhibition or other means "P" document published prior to the international filing date but later than the priority date claimed	"T" later document published after the international filing date or priority date and not in conflict with the application but cited to understand the principle or theory underlying the invention "X" document of particular relevance; the claimed invention cannot be considered novel or cannot be considered to involve an inventive step when the document is taken alone "Y" document of particular relevance; the claimed invention cannot be considered to involve an inventive step when the document is combined with one or more other such documents, such combination being obvious to a person skilled in the art. "&" document member of the same patent family	
Date of the actual completion of the international search 17 May 2010		Date of mailing of the international search report 26/05/2010
Name and mailing address of the ISA/ European Patent Office, P.B. 5818 Patentlaan 2 NL - 2280 HV Rijswijk Tel. (+31-70) 340-2040, Fax: (+31-70) 340-3016		Authorized officer Bumb, Peter

INTERNATIONAL SEARCH REPORT

Information on patent family members

International application No

PCT/EP2010/002006

Patent document cited in search report	Publication date	Patent family member(s)	Publication date
WO 2008100624 A2	21-08-2008	AU 2008216600 A1	21-08-2008
		CA 2678181 A1	21-08-2008
		CN 101674846 A	17-03-2010
		CR 11029 A	29-12-2009
		EC SP099637 A	28-12-2009
		EP 2129396 A2	09-12-2009
		KR 20100014426 A	10-02-2010
		US 2009291085 A1	26-11-2009
WO 2006104911 A2	05-10-2006	AU 2006229989 A1	05-10-2006
		CA 2599988 A1	05-10-2006
		CN 101184506 A	21-05-2008
		EP 1868648 A2	26-12-2007
		JP 2008535821 T	04-09-2008
		KR 20080000613 A	02-01-2008
		SG 159547 A1	30-03-2010
		US 2006270594 A1	30-11-2006
		US 2010028337 A1	04-02-2010
ZA 200707953 A	24-06-2009		
WO 2009134776 A2	05-11-2009	PE 18452009 A1	08-01-2010
		US 2010076178 A1	25-03-2010