

C. M. MORTENSEN.
 CORNER FASTENER FOR GLASS SHOW CASES.
 APPLICATION FILED SEPT. 27, 1909.

952,834.

Patented Mar. 22, 1910.

Fig. 1

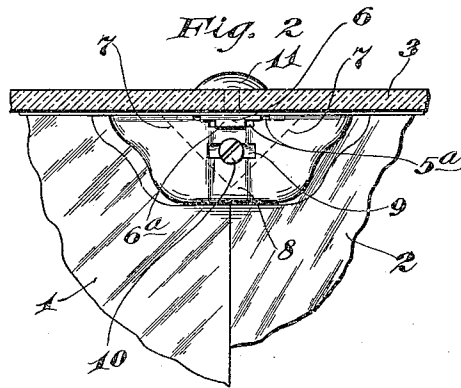
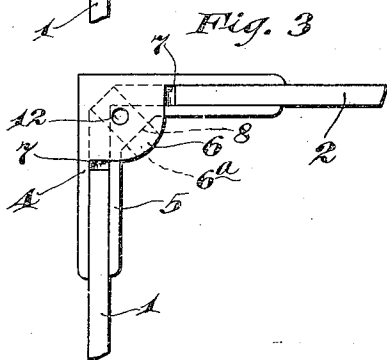
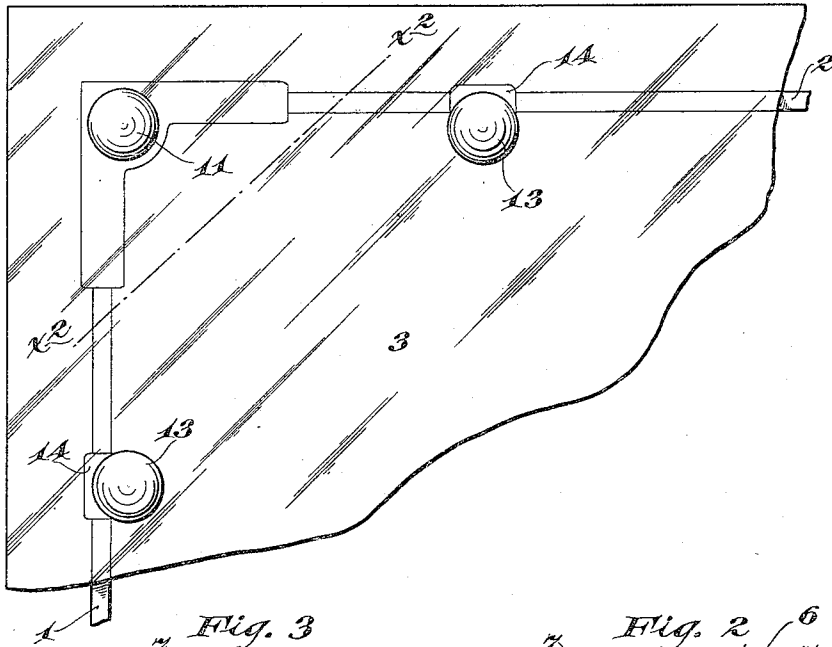
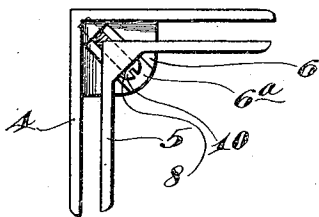

Fig. 4



Witnesses;
 E. C. Skinkle
 L. L. Simpson,

Inventor;
 Carl M. Mortensen,
 By his Attorneys;
 Williamson Merchant

UNITED STATES PATENT OFFICE.

CARL M. MORTENSEN, OF MINNEAPOLIS, MINNESOTA.

CORNER-FASTENER FOR GLASS SHOW-CASES.

Specification of Letters Patent. Patented Mar. 22, 1910.

Application filed September 27, 1909. Serial No. 519,679.

952,834.

To all whom it may concern:

Be it known that I, CARL M. MORTENSEN, a citizen of the United States, residing at Minneapolis, in the county of Hennepin and State of Minnesota, have invented certain new and useful Improvements in Corner-Fasteners for Glass Show-Cases; and I do hereby declare the following to be a full, clear, and exact description of the invention, such as will enable others skilled in the art to which it appertains to make and use the same.

My invention relates to glass show cases and has for its object to provide an improved corner fastener therefor.

To the above ends, the invention consists of the novel devices and combination of devices hereinafter described and defined in the claims.

In the accompanying drawings, which illustrate the invention, like characters indicate like parts throughout the several views.

Referring to the drawings, Figure 1 is a fragmentary plan view, showing one of my improved corner fasteners applied to a glass show case; Fig. 2 is a vertical section taken approximately on the line $x^2 x^2$ of Fig. 1, some parts being broken away; Fig. 3 is a plan view of the corner fastener with the top plate of the case removed; and Fig. 4 is a bottom plan view of the said corner fastener removed from working position.

The numerals 1, 2 and 3 indicate, respectively, the front end and top glass plates of the case. The corner fastener is made up of a rectangular outside bracket 4 and a rectangular inside bracket 5. Within its angle, the outer bracket 4 is provided with a horizontally extended web 6, the upper surface of which is flush with the upper edges of its side portions. On its side, the web 6 is shown as formed with a rib 6^a that extends at an angle of 45 degrees to the sides of the said bracket 4. The upper surface of the corner portion of the inner bracket 5 is cut away at 5^a to afford clearance for the web 6 and its rib 6^a and to permit lateral movements thereof. The glass front and side plates 1 and 2 are overlapped at their abutting ends, but at their upper edges they are cut away at 7 to afford clearance for the web 6 and its rib 6^a, as shown by full lines in Fig. 3 and by dotted lines in Fig. 2. In its inner angle, the inner bracket 5 is provided with a flat surface 8 that extends at

an angle of 45 degrees to both of the side portions of the said bracket and in this flat portion is a transverse slot 9. A screw 10 is passed through the slot 9 and screwed into the thickened angular portion of the outer bracket 4. The portions cut away at 7 from the glass plates 1 and 2 also afford clearance for the screw 10.

When the brackets 4 and 5 are applied as shown in the drawings and the screw 10 is tightened, they will be firmly clamped on to the front and end plates 1 and 2, respectively, and, if one of the said plates should be thicker than the other, the slot 9 and the clearance 6^a will permit the inner bracket to shift its position and thereby evenly clamp the said two plates regardless of their varying thicknesses. To secure the corner of the top plate 3 to the corner bracket, the screw 11, preferably having a rounded head at its upper end, is passed through a perforation in the said plate 3 and is screwed into a threaded seat 12 of the web 6. In this way, the three plates 1, 2 and 3 are securely clamped together at their adjacent corners without danger of breaking the said plates.

If desired, pliable packing strips may be interposed between the glass plates and the metallic portions of the corner fastener, but, usually, this will not be found necessary.

Where the vertical plates 1 and 2 are long, one or more screws 13 and cooperating clips 14 of ordinary construction may be employed to connect the same to the top plate 3.

What I claim is:

1. The combination with glass side, end and top plates of a show case, said side and end plates being cut away at their abutting corners, of a corner fastener comprising rectangular outside and inside brackets engaging said side and end plates, the said outer bracket having at the corner of its upper edge an integral inwardly projecting web seated in a notch in said inner bracket, a screw connecting said inner and outer brackets, and a screw connecting said top plate to said web, substantially as described.
2. The combination with glass side, end and top plates of a show case, the said side and end plates being cut away at their abutting upper corners, of a fastener comprising rectangular outer and inner brackets engaging said side and end plates, said outer bracket having at the upper edge of its an-

gle an inwardly projecting web adjustably fitting a laterally expanded clearance notch in the upper edge of said inner bracket, the said inner bracket have an oblique straight surface in its inner angle and a transverse slot in said flat portion, a screw passed through said slot and screwed into the corner portion of said outer bracket, and a screw passed through said upper plate and

screwed into a seat in said web, substantially as described.

In testimony whereof I affix my signature in presence of two witnesses.

CARL M. MORTENSEN.

Witnesses:

HARRY D. KILGORE,
F. D. MERCHANT.