

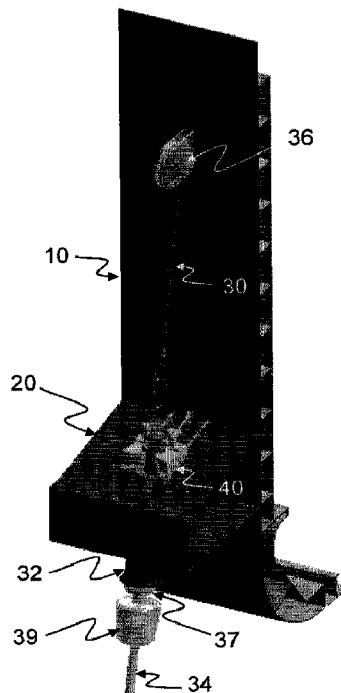

(22) **Date de dépôt/Filing Date:** 2017/09/25
 (41) **Mise à la disp. pub./Open to Public Insp.:** 2018/03/23
 (45) **Date de délivrance/Issue Date:** 2023/07/25
 (30) **Priorité/Priority:** 2016/09/23 (BR BR 10 2016 021963-9)

(51) **Cl.Int./Int.Cl. E21B 17/01** (2006.01)
 (72) **Inventeurs/Inventors:**
 BATISTA DE BARROS, SERGIO, BR;
 VITIELLO, MARCELO COSTA, BR
 (73) **Propriétaire/Owner:**
 PETROLEO BRASILEIRO S.A. - PETROBRAS, BR
 (74) **Agent:** GOWLING WLG (CANADA) LLP

(54) **Titre : SYSTEME ET METHODE AUTONOME DE FIXATION D'UN SUPPORT DE COLONNE MONTANTE**
 (54) **Title: SYSTEM AND AUTONOMOUS METHOD FOR SECURING A RISER SUPPORT**



(57) **Abrégé/Abstract:**

The present invention relates to systems for securing connectors of risers in petroleum production units. In this scenario, the present invention provides an autonomous system for securing a riser support, said system comprising (i) a riser support (32)

(57) Abrégé(suite)/Abstract(continued):

connected at its bottom end to a submerged riser (34) and at its upper end to a tensioning element (30), (ii) a supporting ledge (20) comprising a through-hole (22) through which the tensioning element (30) and at least part of the riser support (32) pass, (iii) a securing device (40) located on the supporting ledge (20), said securing device (40) sliding relative to the supporting ledge (20) and driven by an actuator (48), wherein the securing device (40) slides between an unlocked position and a locked position on the through-hole (22), wherein, in the locked position, the securing device (40) can engage with locking in a connector (38) of the riser support (32) after the connector (38) has passed through the through-hole (22) of the supporting ledge (20). The present invention further provides an autonomous method for securing a riser support associated with the system described above.

ABSTRACT

SYSTEM AND AUTONOMOUS METHOD FOR SECURING A RISER SUPPORT

The present invention relates to systems for securing
5 connectors of risers in petroleum production units. In this scenario, the
present invention provides an autonomous system for securing a riser
support, said system comprising (i) a riser support (32) connected at its
bottom end to a submerged riser (34) and at its upper end to a
tensioning element (30), (ii) a supporting ledge (20) comprising a
10 through-hole (22) through which the tensioning element (30) and at least
part of the riser support (32) pass, (iii) a securing device (40) located on
the supporting ledge (20), said securing device (40) sliding relative to
the supporting ledge (20) and driven by an actuator (48), wherein the
securing device (40) slides between an unlocked position and a locked
15 position on the through-hole (22), wherein, in the locked position, the
securing device (40) can engage with locking in a connector (38) of the
riser support (32) after the connector (38) has passed through the
through-hole (22) of the supporting ledge (20). The present invention
further provides an autonomous method for securing a riser support
20 associated with the system described above.

SYSTEM AND AUTONOMOUS METHOD FOR SECURING A RISER SUPPORT

FIELD OF THE INVENTION

5 [0002] The present invention relates to systems for securing connectors of risers in petroleum production units.

BACKGROUND OF THE INVENTION

[0003] With the discovery of hydrocarbon producing fields
10 located at ever increasing water depths, the use of rigid structures fixed on the sea bed, intended for installation of production equipment, has become more complex by the day. In some cases, owing to the particular conditions of the region where the hydrocarbon producing field is located, their use has become unviable.

15 [0004] In more recent times, floating structures represent an alternative that is used more and more frequently for the installation of production equipment, as they normally offer a lower-cost option compared to fixed structures.

[0005] Petroleum production in deep water makes extensive use
20 of riser pipes, also known as risers. This tubing, which may be flexible or rigid, collects the oil produced by the subsea well, and conveys it to a floating unit, and then to tankers, or directly to onshore installations.

[0006] The installation and dismantling of the risers in the
structure of the floating unit are known as *pull-in* and *pull-out* operations.
25 A pull-in/pull-out cable, connected to a submerged supporting system that supports a riser, suspends an assembly of the riser and supporting system until the connector of the latter engages in a support of the

stationary production unit (SPU) and can be fixed and secured manually.

[0007] The company SBM has developed a system of wedges for fixing and securing the connectors of the supporting systems, especially for supporting systems of the I-tube type, illustrated in Fig. 1.

[0008] The fixing and securing of the connector of the supporting system is carried out with the assistance of divers, since these operations are not fully automated.

[0009] However, since the method for installing flexible risers conventionally employed in the prior art requires the use of divers and the mobilization of support ships, this method is subject to the sea conditions for a certain period of time. This dependence on the weather conditions may generate unexpected delays in projects, owing to the long waiting periods for good diving conditions.

[00010] In an attempt to solve this problem, some techniques for fixing and securing riser supporting systems may be found in the prior art. Some of them are described briefly below.

[0010] Document US7373986B2 discloses a connector for risers comprising a double-click securing system. In the pull-in operation, an enlargement or joint positioned in the upper portion of a riser enters a pocket fixed to the structure of a platform. A joint or enlargement comprises supporting surfaces comprising cams that engage in recesses of the pocket. The pockets are arranged side by side and the engagement of the cams is guided by guides that move the cams angularly until they are located on the recesses. Then the riser is lowered until the cams engage in the recesses.

[0011] Document US5947642A describes a device for coupling flexible risers comprising a tensioner provided with a projection and an angularly moveable retainer for securing the projection automatically

when the tensioner is raised into a cylindrical pocket.

[0012] Document US7967070B2 also discloses a connector comprising a funnel/guide assembly to be coupled to an underwater structure, wherein the funnel/guide assembly receives a shaft. The shaft is coupled to a tensioner. A securing assembly is coupled to the funnel/guide assembly, wherein the securing assembly comprises a securing device. Retainers move into and out of the funnel/guide assembly, wherein the retainers are inserted into recesses of the shaft for securing the axial movement of the shaft relative to the funnel/guide assembly. The connector is installed and secured using a remotely operated vehicle (ROV).

[0013] Although the prior art comprises various devices and systems for securing supporting systems or tensioners of risers, many of them are complex and/or require precise adjustments for said securing. Moreover, many will need at least the assistance of a ROV, which may make the pull-in/pull-out operation unviable in extreme sea conditions.

[0014] As will be explained in detail hereunder, the present invention aim is to provide a simple, low-cost alternative for automatic installation and securing of supporting systems.

SUMMARY OF THE INVENTION

[0015] It is an aim to provide a system and autonomous method for securing a riser support that preferably does not require diving operations for manual connection and disconnection of the system or the need for the assistance of a ROV.

[0016] Thus, in order to achieve this aim, the present disclosure provides an autonomous system for securing or releasing a riser support, wherein the autonomous system comprises at least one or more of the following features: a riser support connectable at its bottom

end to a submerged riser and at its upper end to a tensioning element, the riser support having a connector; a supporting ledge comprising a through-hole, through which the tensioning element and at least part of the riser support may pass; a securing device located on the supporting ledge, said securing device being slidable relative to the supporting ledge and driven by an actuator; wherein the securing device is configured to slide, with respect to the through-hole, between an unlocked position and a locked position, wherein, in the locked position, the securing device can engage the connector of the riser support after the connector has passed through the through-hole of the supporting ledge, so as to prevent the connector from passing back through the through-hole.

[0017] According to another aspect of the disclosure, there is provided an autonomous method for securing a riser support, wherein the method comprises one or more of the steps of: passing, through a through-hole of a supporting ledge, at least part of a riser support connected at its bottom end to a submerged riser and at its upper end to a tensioning element; and sliding, relative to the supporting ledge, a securing device located on the supporting ledge, said securing device being driven by an actuator, wherein the securing device slides between an unlocked position and a locked position relative to the through-hole, wherein, in the locked position, the securing device can engage with a connector of the riser support after the connector has passed through the through-hole of the supporting ledge, so as to prevent the connector from returning through the through-hole.

[0018] According to another aspect of the disclosure, there is provided an autonomous method for releasing a riser support, wherein the method comprises one or more of the steps of: providing a securing device in a locked position on a supporting ledge, engaged with a riser

support, so as to prevent the riser support passing through a through-hole of a supporting ledge, wherein the riser support is connected at its bottom end to a submerged riser and at its upper end to a tensioning element; sliding, relative to the supporting ledge, the securing device, said securing device being driven by an actuator, wherein the securing device slides between the locked position and an unlocked position relative to the through-hole in the supporting ledge, so as to disengage from the riser support; and passing, through the through-hole of the supporting ledge, at least part of the riser support.

10 [0019] According to another aspect of the disclosure, there is provided an autonomous system for securing a riser support, comprising (i) a riser support connected at its bottom end to a submerged riser and at its upper end to a tensioning element, (ii) a supporting ledge comprising a through-hole through which the tensioning element and at least part of the riser support pass, and (iii) a securing device located on the supporting ledge, the securing device sliding relative to the supporting ledge and actuated by an actuating means, wherein the securing device slides between an unlocked position and locked position on the through-hole, wherein, in the locked position, the securing device can engage with locking in a connector of the riser support after the connector has passed through the through-hole of the supporting ledge.

[0020] The present disclosure further provides an autonomous method for securing a riser support, comprising the steps of (i) passing, through a through-hole of a supporting ledge, at least part of a riser support connected at its bottom end to a submerged riser and at its upper end to a tensioning element and (ii) sliding, relative to the supporting ledge, a securing device located on the supporting ledge, the securing device being actuated by an actuating means, wherein the

securing device slides between an unlocked position and a locked position on the through-hole, wherein, in the locked position, the securing device can engage with locking in a connector of the riser support after the connector has passed through the through-hole of the supporting ledge.

5 [0021] According to one aspect of the disclosure, there is proposed an autonomous system for securing a riser support, characterized in that it comprises one or more of the following features: a riser support connected at its bottom end to a submerged riser and at its upper end to a tensioning element; a supporting ledge comprising a through-hole, through which the tensioning element and at least part of the riser support pass; a securing device located on the supporting ledge, said securing device sliding relative to the supporting ledge and driven by an actuator; wherein the securing device slides between an unlocked position and a locked position on the through-hole, wherein, in the locked position, the securing device can engage with locking in a connector of the riser support after the connector has passed through the through-hole of the supporting ledge.

15 [0022] A further aspect of the disclosure provides that the securing device slides on at least one rail located on the supporting ledge.

20 [0023] A further aspect of the disclosure provides that the securing device is lockable in the locked position by means of at least one locking pin that can engage in at least one securing hole of the supporting ledge.

[0024] A further aspect of the disclosure provides that the at least one locking pin is driven by at least one hydraulic locking cylinder.

25 [0025] A further aspect of the disclosure provides that the actuator is at least one hydraulic displacement cylinder.

[0026] A further aspect of the disclosure provides that the securing device comprises a horseshoe shape where there is a front opening for

positioning said securing device around the connector of the riser support.

[0027] A further aspect of the disclosure provides that the securing device comprises an upper surface that comes into contact with the connector of the riser support, inclined in at least one direction relative to a bottom surface.

[0028] A further aspect of the disclosure provides that the inclination of the upper surface of the securing device relative to at least one direction corresponds to at least one of the catenary angle and the azimuth angle of the riser.

[0029] A further aspect of the disclosure provides that the riser support is a support of the I-tube type or MFBM.

[0030] A further aspect of the disclosure provides an autonomous method for securing a riser support, characterized in that it comprises one or more of the steps of: passing, through a through-hole of a supporting ledge, at least part of a riser support connected at its bottom end to a submerged riser and at its upper end to a tensioning element; sliding, relative to the supporting ledge, a securing device located on the supporting ledge, said securing device being driven by an actuator, wherein the securing device slides between an unlocked position and a locked position on the through-hole, wherein, in the locked position, the securing device can engage with locking in a connector of the riser support after the connector has passed through the through-hole of the supporting ledge.

[0031] A further aspect of the disclosure provides that it comprises an additional step of locking the securing device in the locked position by means of at least one locking pin that can engage in at least one securing hole of the supporting ledge.

[0032] A further aspect of the disclosure provides that it comprises

an additional step of unlocking the securing device in the locked position by releasing at least one locking pin of the at least one securing hole of the supporting ledge.

[0033]

5 BRIEF DESCRIPTION OF THE FIGURES

[0034] The detailed description presented hereunder refers to the appended figures and their respective reference numbers, representing the embodiments of the present disclosure.

10 [0035] Fig. 1 shows a system of wedges for fixing and securing connectors of supporting systems of the I-tube type as known in the prior art.

[0036] Fig. 2 shows an isometric view of a portion of a body of a SPU where the system of the present disclosure can be installed.

15 [0037] Fig. 3 shows a detailed isometric view of a preferred embodiment of the system of the present disclosure in a locked position.

[0038] Fig. 4 shows an isometric view of the preferred embodiment of the system of the present disclosure in an unlocked position where a connector has not yet passed through a through-hole of a supporting ledge.

20 [0039] Fig. 5 shows an isometric view of the preferred embodiment of the system of the present disclosure in an unlocked position where the connector is passing through a through-hole of the supporting ledge.

25 [0040] Fig. 6 shows an isometric view of the preferred embodiment of the system of the present disclosure in an unlocked position where the connector has already passed through a through-hole of the supporting ledge.

[0041] Fig. 7 shows an isometric view of the preferred embodiment of the system of the present disclosure in an intermediate

position where a securing device is being moved for securing the connector.

[0042] Fig. 8 shows a detailed isometric view of the preferred embodiment of the system of the present disclosure in the locked position.

[0043] Fig. 9 shows a detailed isometric view of the securing device according to a preferred disclosure of the present invention.

[0044] Fig. 10 shows four views of the securing device of Fig. 9, namely a front view, a side view, a bottom view and an isometric bottom view.

DETAILED DESCRIPTION OF THE INVENTION

[0045] Firstly, it is emphasized that the description that follows will be based on a preferred embodiment of the disclosure. As will be obvious to a person skilled in the art, however, the invention is not limited to this particular embodiment.

[0046] Figs. 2 to 8 show isometric views of a portion of a body **10** of a stationary production unit (SPU) where the system of the present disclosure is installed.

[0047] The present system comprises a supporting ledge **20**, which is submerged. The ledge **20** comprises a through-hole **22** through which a tensioning element **30** can pass. Tensioning element **30** is a steel cable in some embodiment. In some embodiments, tensioning element **30** is at least part of a riser support **32**. The supporting ledge **20** is fixed relative to the body **10** of the SPU.

[0048] A riser support **32**, which can also make up part of the proposed system, is connected at its bottom end to a submerged riser **34**. The riser support **32** is connected at its upper end to the tensioning element **30**.

[0049] In some embodiments, the riser support **32** is a support of

the I-tube type or of the multifunctional bell mouth (MFBM) type, usually employed for supporting risers in SPUs.

[0050] Optionally, the tensioning element **30** passes via a deflection pulley **36**. This allows for directing the loading of the riser support **32** and, consequently, of the submerged riser **34**.

[0051] Once the tensioning element **30** and at least part of the riser support **32** have passed through the through-hole **22** (as shown in Fig. 3), as a result of the tensioning of the tensioning element **30**, the riser support **32** can be secured relative to the supporting ledge **20** by means of a securing device **40** positioned thereon.

[0052] The securing device **40** slides between an unlocked position (Figs. 4 to 6), away from the through-hole **22**, and a locked position (Fig. 8) on the through-hole **22**.

[0053] In some embodiments, the securing device **40** slides on at least one rail **24**. The rail **24** can be located on the supporting ledge **20**. In some embodiments, two rails are provided on the supporting ledge **20** for sliding of the securing device **40**, as illustrated in the detail in Fig. 2. Optionally, stops **25** are positioned at one or both ends of any rail, to limit the movement of the securing device **40**.

[0054] In the locked position, the securing device **40** can engage with locking in a connector **38** of the riser support **32** after the connector **38** has passed through the through-hole **22** of the supporting ledge **20**, so as to prevent the connector **38** from passing back through the through-hole. That is, once the connector has passed through the through-hole **22** to be on the same side of the through-hole **22** as the securing device **40**, the securing device **40** can prevent the connector **38** from returning. In some embodiments, the connector **38** comprises an annular projection for coupling into the securing device **40**.

[0055] In some embodiments, the securing device **40** comprises

a horseshoe shape, where there is a front opening **42** for positioning said securing device **40** around the connector **38** of the riser support **32** and coupling to the annular projection thereof. That is, the front opening **42** can fit under the annular projection on the riser support **32**, and the
5 tension in the riser support **32** then biases the annular projection towards the securing device **40**, thus securing riser support **32** against the securing device **40**. This is discussed in further detail below.

[0056] Preferably, the securing device **40** is lockable in the locked position by means of at least one locking pin **44**. In some
10 embodiments, locking pin **44** can engage in at least one securing hole **26** of the supporting ledge **20** (as shown in Fig. 2). In some embodiments, two locking pins are provided for coupling in two securing holes of the supporting ledge **20**.

[0057] In some embodiments, the at least one locking pin **44** is
15 actuated by at least one hydraulic locking cylinder **46**. Thus, when the securing device **40** is in the locked position, the at least one hydraulic locking cylinder **46** actuates the at least one locking pin **44** for coupling into the at least one securing hole **26** of the supporting ledge **20** and for securing the riser support **32**. That is, the hydraulic locking cylinder can
20 hydraulically propel the pin **44** into the securing hole **26**. To disconnect the system, the at least one hydraulic locking cylinder **46** can be actuated so as to uncouple the at least one locking pin **44** from the at least one securing hole **26** of the supporting ledge **20**. In this way, the securing device **40** becomes free to move between the locked and
25 unlocked positions. Sliding the securing device **40** to the unlocked position removes the securing device **40** from underneath the annular projection of the connector **38** of riser support **32**, thus releasing the riser support **32** from the securing device **40**.

[0058] Sliding of the securing device **40** between the locked and

unlocked positions is effected by means of an actuator **48**. In some embodiments, the actuator **48** is at least one hydraulic displacement cylinder. The hydraulic displacement cylinder can be fixed at one end to the securing device **40**. The other end of the hydraulic displacement cylinder can be fixed to a fixing element **49** of the supporting ledge **20**.

5 [0059] In some embodiments, the securing device **40** can further comprise an upper surface, which will come into contact with the connector **38** of the riser support **32**. The upper surface can be inclined in at least one direction relative to a bottom surface of the securing device **40**, as illustrated in the front and side views in Fig. 10. As can be seen, angles **X** and **Y** are formed in two mutually perpendicular directions. This promotes better coupling of the upper surface of the securing device **40** with the connector **38** of the riser support **32**. In other words, the sloped upper surface discourages the connector **38** from sliding out of the securing device **40** whilst the securing device **40** is in the locked position. The angles **X** and **Y** will vary according to the catenary angle and/or the azimuth angle of the riser **34**. In some embodiments, the angles **X** and **Y** can correspond to the catenary angle and/or the azimuth angle of the riser **34**. The angles **X** and **Y** can also vary according to the angle of the supporting ledge **20**.

15 [0060] In some embodiments, a centralizing cap **37** (e.g. see Fig. 4) is provided below the riser support **32**. Also, in some embodiments, a flexible joint (also known as a flex joint) **39** is provided at the upper end of the riser **34** (i.e. below the riser support **32**, as shown in Fig 6, or below the centralizing cap **37**, if present, as shown in Fig. 5).

20 [0061] Optionally, each of the components of the system of the present invention may be treated with at least one of a sliding coating, in the case of moving parts, and an antifouling coating.

[0062] The present disclosure also provides a method associated

with the system proposed above, comprising the steps of:(a) passing, through the through-hole **22** of the supporting ledge **20**, at least part of the riser support **32** connected at its bottom end to the submerged riser **34** and at its upper end to the tensioning element **30**; and(b) Sliding, relative to the supporting ledge **20**, the securing device **40** located on the supporting ledge **20**, the securing device **40** being driven by the actuator **48**.

[0063] In the proposed method, the securing device **40** can slide between an unlocked position and a locked position on the through-hole **22**. In the locked position, the securing device **40** can engage with locking in the connector **38** of the riser support **32** after the connector **38** has passed through the through-hole **22** of the supporting ledge **20**.

[0064] The steps of the method can be performed with out direct user manipulation, and can instead be performed remotely. That is the action of passing the riser support **32** through the through-hole **22** can be controlled by applying tension to the tensioning element **30** through a remotely controlled tensioning or winding system, for example. The action of sliding can be controlled by remotely operating actuator **48**.

[0065] In some embodiments, the method can comprise an additional step of locking the securing device **40** in the locked position by means of at least one locking pin **44**. The locking pin **44** can be a pin that engages in at least one securing hole **26** of the supporting ledge **20**.

[0066] In some embodiments, the method can comprise an additional step of unlocking the securing device **40** from the locked position. This can be achieved by releasing at least one locking pin **44** from the at least one securing hole **26** of the supporting ledge **20**.

[0067] Thus, the present disclosure provides a system and an autonomous method for securing a riser support that does not require

diving operations for manual connection and disconnection of the system or the need for the assistance of a ROV.

[0068] Numerous variations falling within the scope of protection of the present application are permitted. Thus, it is emphasized that the present invention is not limited to the particular configurations/embodiments described above. Modification of the above-described apparatuses and methods, combinations between different variations as practicable, and variations of aspects of the invention that are obvious to those of skill in the art are intended to be within the spirit and scope of the claims.

CLAIMS:

1. A system for securing or releasing a riser support, comprising:
 - a riser support having a bottom end and an upper end, the riser support being connectable at its bottom end to a submerged riser and at its upper end to
 - 5 a tensioning element, the riser support having a connector;
 - a supporting ledge comprising a through-hole, the through-hole being configured to allow passage of the tensioning element and at least part of the riser support; and
 - a securing device located on the supporting ledge, said securing device
 - 10 being slidable along the supporting ledge from an upper position to a lower position and driven by an actuator;
 - wherein the securing device is configured to slide, with respect to the through-hole, between an unlocked position and a locked position, and
 - wherein, in the locked position, the securing device is configured to engage
 - 15 the connector of the riser support after the connector has passed through the through-hole of the supporting ledge, so as to prevent the connector from passing back through the through-hole.
2. The system for securing or releasing a riser support according to claim 1,
- 20 wherein the securing device slides on at least one rail located on the supporting ledge.
3. The system for securing or releasing a riser support according to claim 1 or 2, wherein the securing device is configured to be locked in the locked position by means of at least one locking pin that is configured to engage in at least one securing hole of the supporting ledge.
- 25 4. The system for securing or releasing a riser support according to claim 3, further comprising at least one hydraulic locking cylinder for driving the at least one locking pin.

5. The system for securing or releasing a riser support according to any one of claims 1 to 4, wherein the actuator is at least one hydraulic displacement cylinder.
6. The system for securing or releasing a riser support according to any one of
5 claims 1 to 5, wherein the securing device comprises a horseshoe shape in which there is an opening for positioning said securing device around the connector of the riser support in the locked position.
7. The system for securing or releasing a riser support according to any one
10 of claims 1 to 6, wherein the securing device comprises an upper surface and a lower surface, wherein the upper surface comes into contact with the connector of the riser support, and is inclined in at least one direction relative to the lower surface.
8. The system for securing or releasing a riser support according to claim 7,
15 wherein the inclination of the upper surface of the securing device relative to at least one direction corresponds to at least one of the catenary angle and the azimuth angle of the riser.
9. The system for securing or releasing a riser support according to any one of claims 1 to 8, wherein the riser support is a support of an I-tube type or a multifunctional bell mouth MFBM type.
- 20 10. The system for securing or releasing a riser support according to any one of claims 1 to 9, further comprising a deflection pulley, wherein the tensioning element passes via the deflection pulley.
11. A method for securing a riser support, wherein the method comprises the steps of:
25 passing, through a through-hole of a supporting ledge, at least a part of a riser support having a bottom end and an upper end and being connected at its bottom end to a submerged riser and at its upper end to a tensioning element; and

sliding, along the supporting ledge, a securing device located on the supporting ledge, from an upper position to a lower position, said securing device being driven by an actuator;

wherein the securing device slides between an unlocked position and a
5 locked position relative to the through-hole, and

wherein, in the locked position, the securing device is configured to engage with a connector of the riser support after the connector has passed through the through-hole of the supporting ledge, so as to prevent the connector from returning through the through-hole.

10 12. The method for securing a riser support according to claim 11, wherein the method comprises an additional step of locking the securing device in the locked position by means of at least one locking pin that is configured to engage in at least one securing hole of the supporting ledge.

13. The method for securing a riser support according to claim 12, wherein the
15 method comprises an additional step of unlocking the securing device from the locked position by releasing the at least one locking pin of the at least one securing hole of the supporting ledge.

14. A method for releasing a riser support, wherein the method comprises the steps of:

20 providing a securing device in a locked position on a supporting ledge, engaged with a riser support, so as to prevent the riser support passing through a through-hole of the supporting ledge, wherein the riser support has a bottom end and an upper end and is connected at its bottom end to a submerged riser and at its upper end to a tensioning element;

25 sliding, along the supporting ledge, the securing device, from an upper position to a lower position, said securing device being driven by an actuator, wherein the securing device slides between the locked position and an unlocked position relative to the through-hole in the supporting ledge, so as to disengage from the riser support; and

passing, through the through-hole of the supporting ledge, at least part of the riser support.

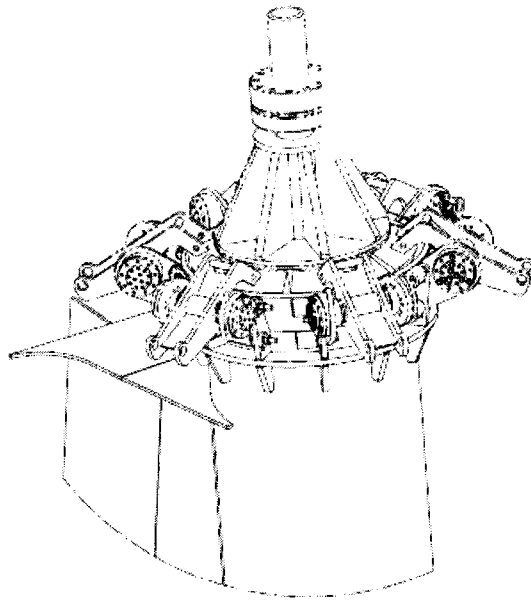

FIG. 1
(prior art)

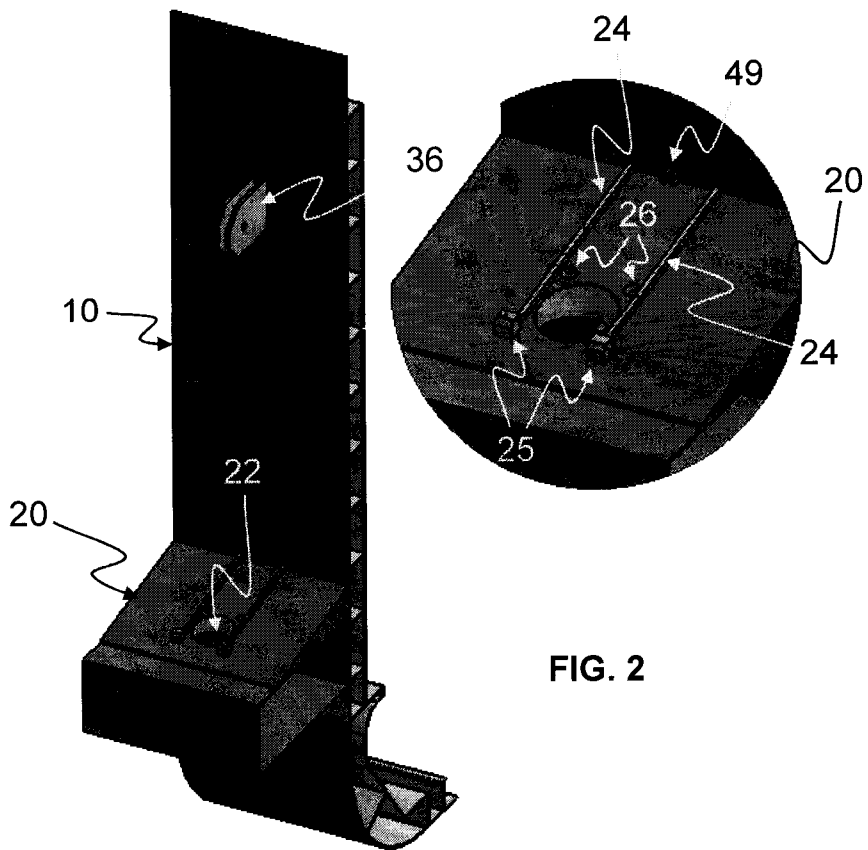

FIG. 2

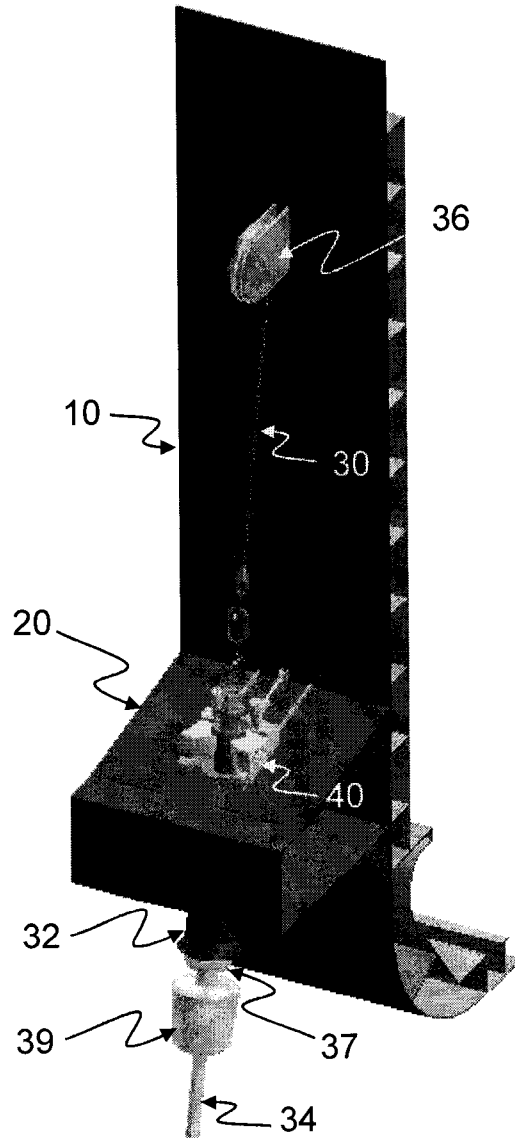

FIG. 3

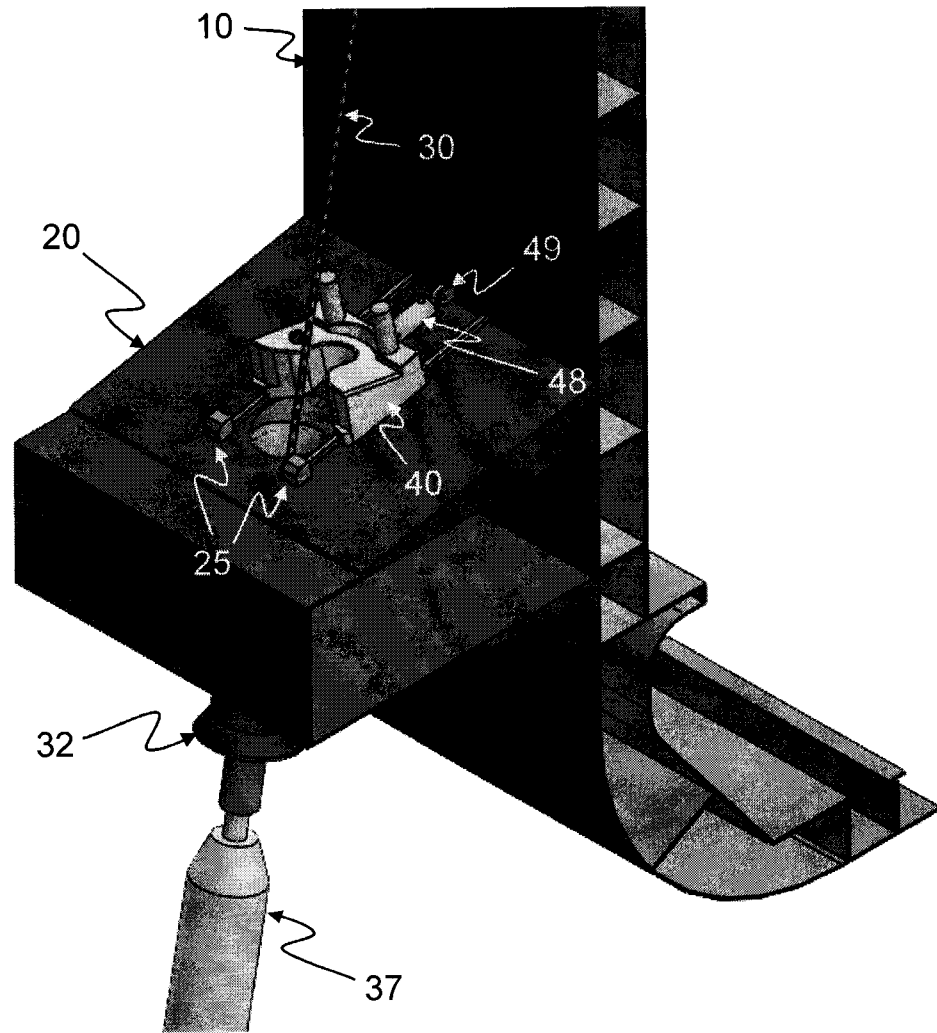

FIG. 4

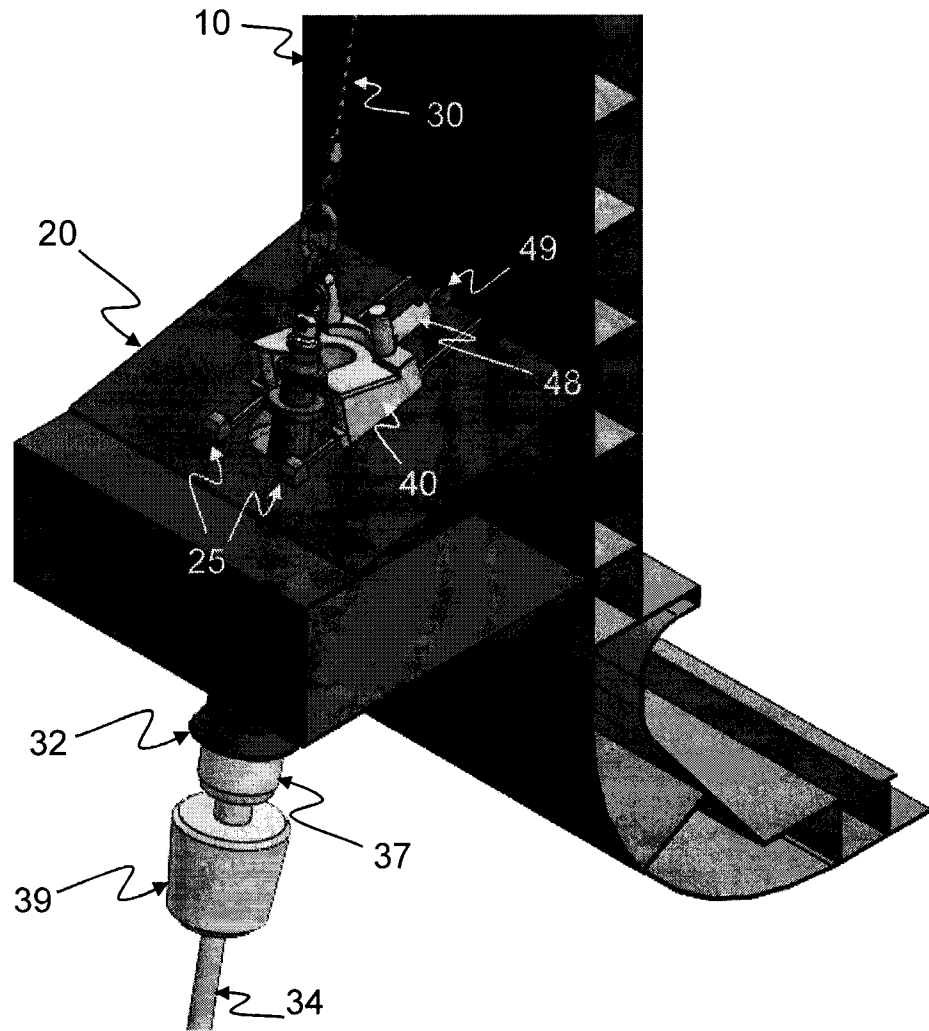

FIG. 5

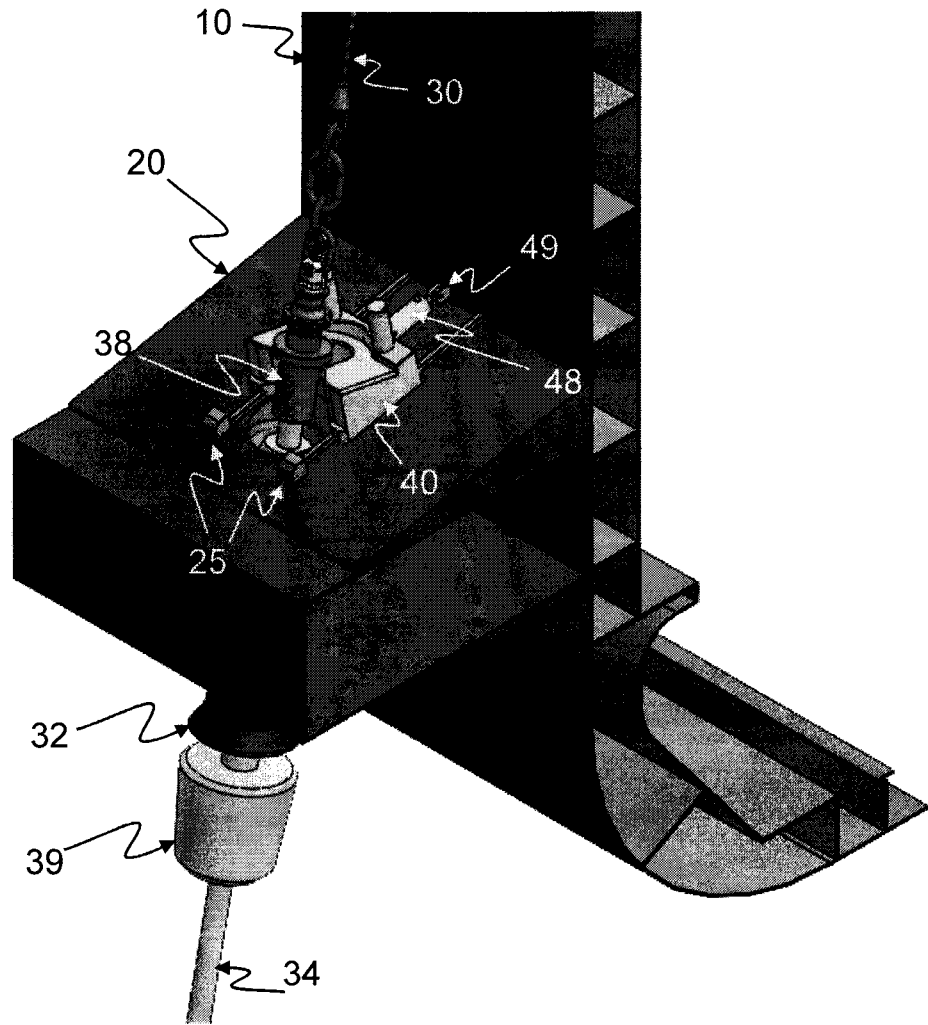

FIG. 6

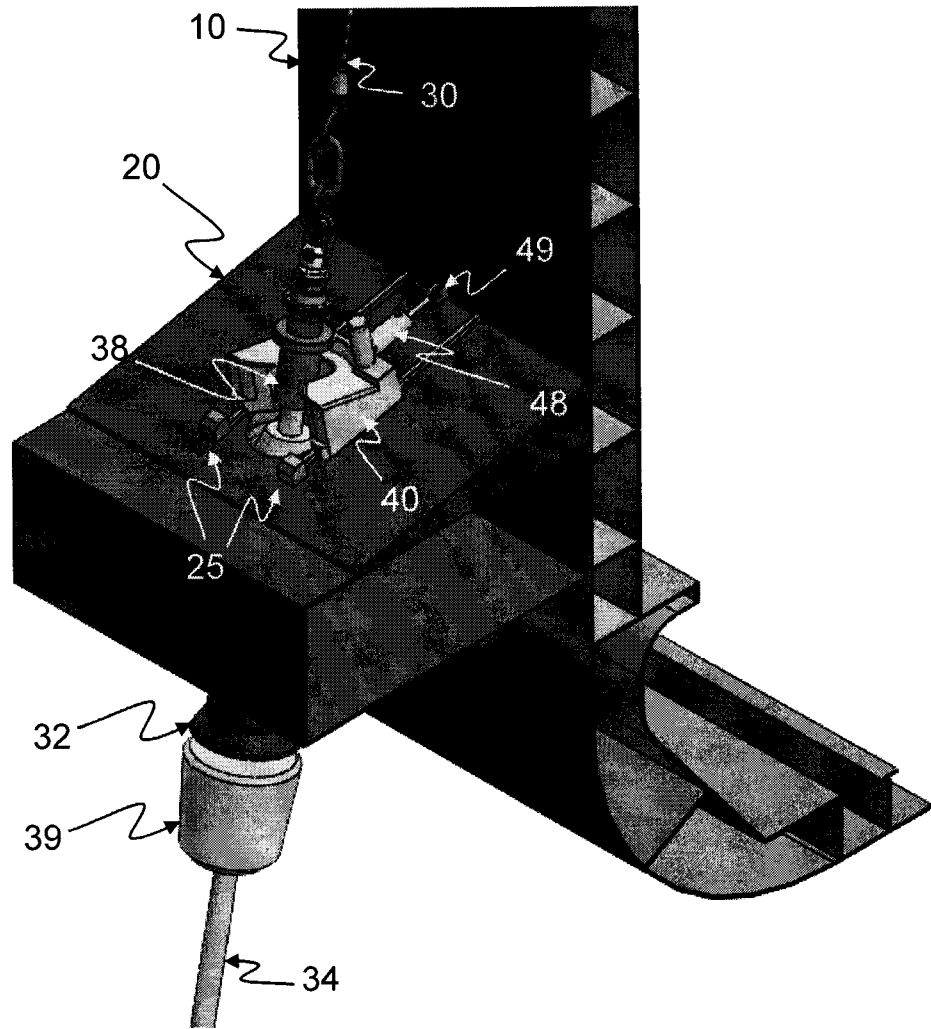

FIG. 7

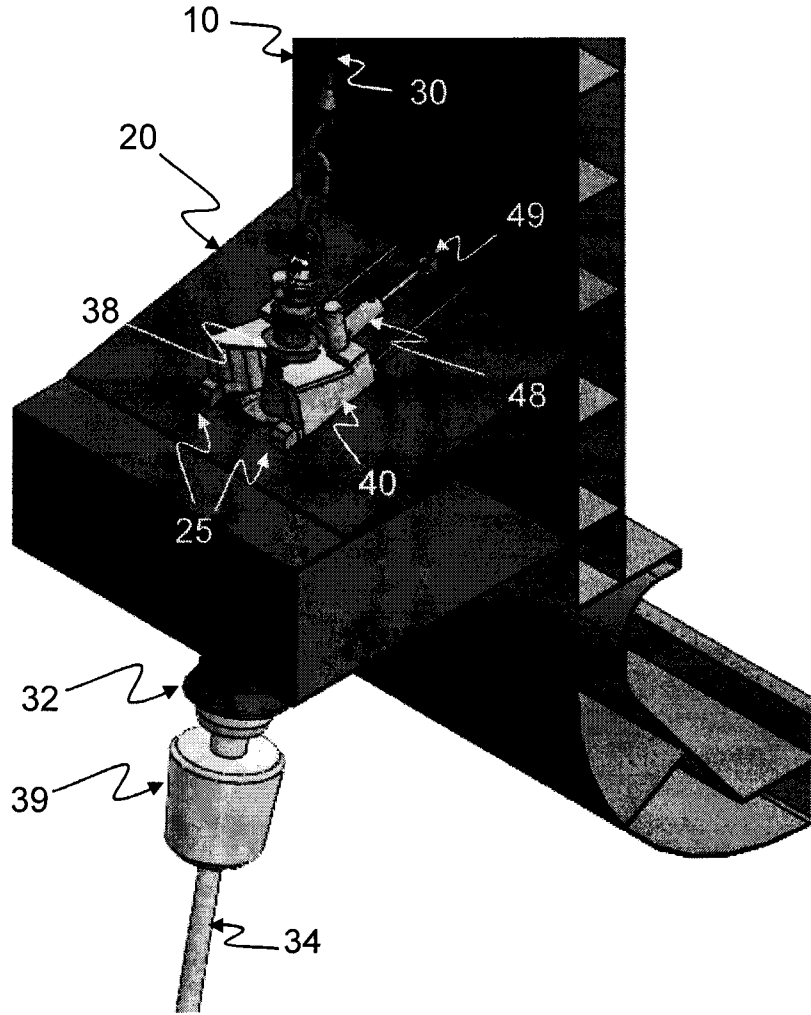

FIG. 8

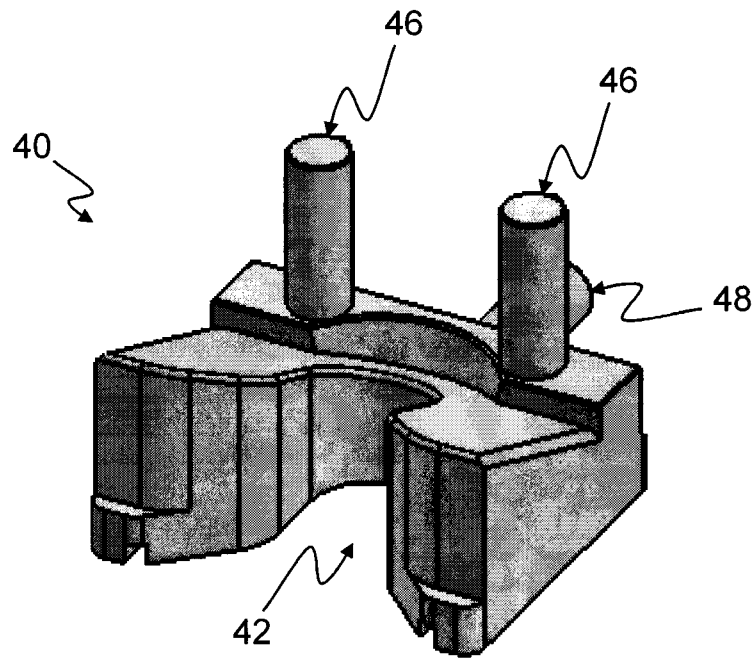

FIG. 9

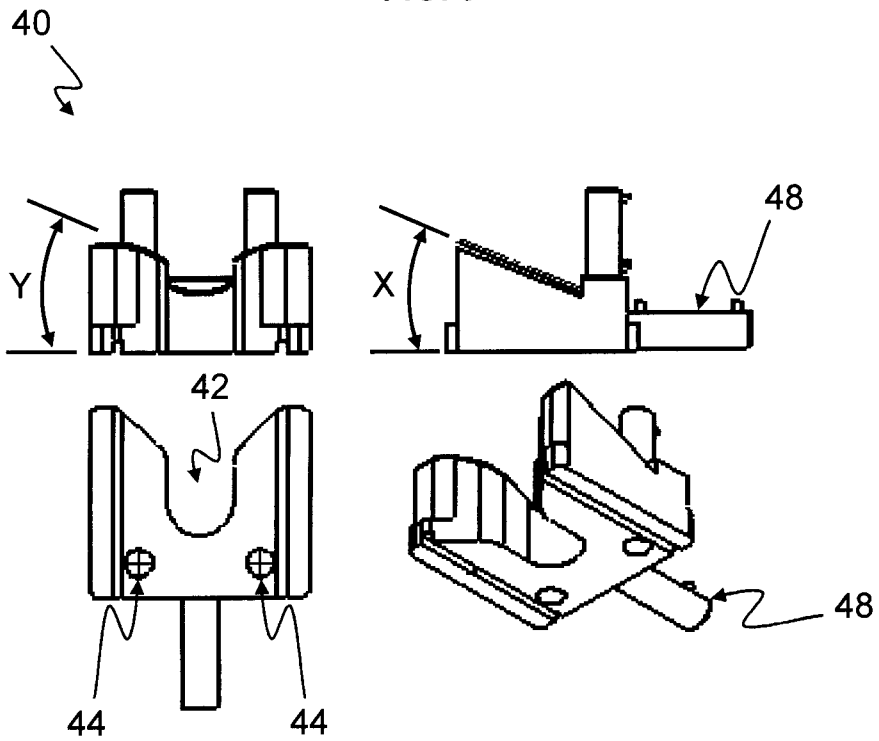

FIG. 10

