

(19) **DANMARK**

(10) **DK/EP 3030110 T3**



(12) **Oversættelse af
europæisk patentskrift**

Patent- og
Varemærkestyrelsen

-
- (51) Int.Cl.: **A 47 C 21/02 (2006.01)** **A 47 C 21/00 (2006.01)** **A 47 C 21/08 (2006.01)**
- (45) Oversættelsen bekendtgjort den: **2021-05-25**
- (80) Dato for Den Europæiske Patentmyndigheds bekendtgørelse om meddelelse af patentet: **2021-02-24**
- (86) Europæisk ansøgning nr.: **13891207.6**
- (86) Europæisk indleveringsdag: **2013-08-06**
- (87) Den europæiske ansøgnings publiceringsdag: **2016-06-15**
- (86) International ansøgning nr.: **US2013053729**
- (87) Internationalt publikationsnr.: **WO2015020635**
- (84) Designerede stater: **AL AT BE BG CH CY CZ DE DK EE ES FI FR GB GR HR HU IE IS IT LI LT LU LV MC MK MT NL NO PL PT RO RS SE SI SK SM TR**
- (73) Patenthaver: **Tempur World, LLC, 1000 Tempur Way, Lexington, KY 40511, USA**
- (72) Opfinder: **ESKRIDGE III, Horace Robert, 1120 Brentsville Road, Paris, KY 40361, USA**
BURTON, Leslie Allen, 744 Sunny Slope Trace, Lexington, KY 40514, USA
- (74) Fuldmægtig i Danmark: **Chas. Hude A/S, H.C. Andersens Boulevard 33, 1780 København V, Danmark**
- (54) Benævnelse: **Holdestanganordning**
- (56) Fremdragne publikationer:
EP-A1- 2 111 774
JP-U- S61 165 664
US-A- 4 458 371
US-A1- 2010 229 309
US-A1- 2012 017 373
US-B1- 7 607 181
US-B2- 6 886 196

DESCRIPTION

TECHNICAL FIELD

[0001] The present invention relates to a retainer bar assembly for use with an adjustable base for a support cushion, according to the preamble part of claim 1. Such a retainer bar assembly is known from JP S61 165664 U. In particular, the present invention relates to a retainer bar assembly that includes brackets having channels configured to allow a retainer bar to be moved upward and rotated away from an adjustable base, such that a support cushion lying on the adjustable base can then be easily manipulated.

BACKGROUND

[0002] Bed assemblies that make use of adjustable bases are becoming increasingly popular as an alternative to traditional bed assemblies. Unlike traditional bed assemblies that make use of rigid box springs or other similar bases, a bed assembly that makes use of an adjustable base can readily be adjusted by articulating the base into a desired ergonomic position. In other words, by articulating the adjustable base, a user can readily change the position of the mattress lying on the adjustable base and, consequently, can quickly match the position of the mattress to their specific preferences and, at least partially, individualize his or her level of sleep comfort.

[0003] Despite the readily adjustable nature of such bed assemblies, the use of adjustable bases frequently leads to difficulties in manipulating the mattresses lying on top of the bases. More particularly, in a bed assembly that makes use of an adjustable base, the adjustable base often includes a retainer bar rigidly secured to the foot of the base that holds the mattress firmly in position atop the base and prevents the mattress from sliding off of the base when it is articulated. In using such a rigid retainer bar, however, the retainer bar also acts to prevent the mattress from easily being manipulated, such as what may be necessary to rotate the mattress or change the sheets covering the mattress.

SUMMARY

[0004] The present invention provides a retainer bar assembly for use with an adjustable base for a support cushion as claimed in claim 1. In particular, the present invention relates to a retainer bar assembly that includes brackets having channels configured to allow a retainer bar to be moved upward and rotated away from an adjustable base, such that a support cushion lying on the adjustable base can then be easily manipulated. Thus, the retainer bar assemblies of the present invention allow a user to obtain the benefits of a bed assembly having an adjustable base, but without the difficulty that is frequently encountered in manipulating a

mattress around a rigid retainer bar to rotate the mattress or change the sheets covering the mattress.

[0005] In one exemplary embodiment of the present invention, a retainer bar assembly is provided as part of a bed assembly that includes an adjustable base and a support cushion in the form of a mattress. The retainer bar assembly is positioned at a lower end of the upper surface of the adjustable base. The retainer bar assembly includes a retainer bar that is configured to secure the mattress on the adjustable base when the retainer bar is in a lowered position. In this regard, the retainer bar includes a horizontal rod as well as two legs, which each include an upright portion, a curved lower portion, and an end portion that extends in a direction substantially parallel to the horizontal rod. The two legs are connected to the horizontal rod and have a height that allows the horizontal rod to rest against the mattress when the retainer bar is in the lowered position to assure that the mattress remains secured to the adjustable base when the base is articulated.

[0006] To secure the retainer bar to the adjustable base, the retainer bar assembly further includes a pair of brackets that are attached to two support members extending longitudinally along the opposite sides of the adjustable base, with one bracket being attached to one of the two support members and the second bracket being attached to the other support member. Each bracket generally defines a first channel and a second channel that are positioned on opposite sides of each bracket and are configured to receive the end portions of each of the two legs. Unlike the rigidly-attached retainer bar assemblies traditionally used with adjustable bases, however, each channel of the brackets of the retainer bar assemblies of the present invention includes a vertical segment and an angled segment, such that each channel is configured to allow the horizontal rod to be moved (e.g., pulled) upward and then rotated away from each bracket.

[0007] To secure the retainer bar in each bracket and prevent the disengagement of the end portions of the two legs of the retainer bar from the channels in the brackets, as well as from the brackets themselves, the retainer bar assembly further includes a cap for covering an open top of each bracket. Each of the caps defines a first slot and a second slot with one of the two legs of the retainer bar typically housed in the first slot of one cap and the second of the two legs of the retainer bar typically housed in the second slot of the second cap. The slots of the caps are substantially parallel to one another and have a length that extends longitudinally along a top surface of the cap. In this regard, when the horizontal rod of the retainer bar is moved upward and rotated away from each bracket, the slots are configured to allow the legs to move along the length of the slots as the horizontal rod is rotated away from each bracket. In some embodiments, to further facilitate the rotating of the horizontal rod of the retainer bar away from each bracket, the slots also include an open end adjacent to an upper edge of a foot board of the adjustable base, such that the two legs are rotated against the upper edge of the foot board as the horizontal rod is rotated away from each bracket.

[0008] To further secure the retainer bar in each bracket and, in particular, the end portions of the legs of the retainer bar, each cap further comprises at least one fin that extends

downwardly from the cap into each bracket and acts to secure the end portion of a particular leg in a particular channel of a bracket. In some embodiments, the cap includes a first fin and a second fin extending downwardly from the cap, such that, upon using the cup to cover the open top of each bracket, the first fin extends into the bracket adjacent to the first slot and the second fin extends into the bracket adjacent to the second slot to secure the end portion of a particular leg in either the first channel or the second channel.

[0009] With further respect to the caps of the retainer bar assembly of the present invention, each cap also generally includes a lip for securing the cap to a corresponding rim of each bracket. In some embodiments the cap further defines an opening for inserting a fastener through the cap. In such embodiments, once the fastener has been inserted through the opening in the cap, the fastener can then be placed in a corresponding bore in each bracket to thereby further secure the cap to each bracket and prevent the cap and the retainer bar from being pulled from the adjustable base as the horizontal bar is being pulled upward and rotated away from the brackets.

[0010] Further features and advantages of the present invention will become evident to those of ordinary skill in the art after a study of the description, figures, and non-limiting examples in this document.

BRIEF DESCRIPTION OF THE DRAWINGS

[0011]

FIG. 1 is a perspective view of an exemplary adjustable bed assembly with the mattress removed from the bed assembly to show an exemplary retainer bar assembly made in accordance with the present invention in a lowered position:

FIG. 2 is another perspective view of the exemplary adjustable bed assembly of FIG. 1. but with the retainer bar rotated away from the brackets of the retainer bar assembly;

FIG. 3 is an exploded perspective view of the exemplary retainer bar assembly of FIGS. 1-2:

FIG. 4 is a partial cross-sectional view of the exemplary bed assembly of FIG. 1, but with the mattress, a portion of the adjustable base, and a portion of one of the brackets removed to show the interior of the bracket;

FIG. 5 is a partial perspective view of the exemplary bed assembly of FIG. 1, but with the mattress and a portion of the adjustable base removed to show the retainer bar in a lowered position in the one of the brackets of the retainer bar assembly and

FIG. 6 is a partial perspective view of the exemplary bed assembly of FIG. 1, but with the mattress and a portion of the adjustable base removed to show the retainer bar in a raised position in the one of the brackets of the retainer bar assembly.

DESCRIPTION OF EXEMPLARY EMBODIMENTS

[0012] The present invention relates to a retainer bar assembly for use with an adjustable base for a support cushion. In particular, the present invention relates to a retainer bar assembly that includes brackets having channels configured to allow a retainer bar to be moved upward and rotated away from an adjustable base, such that a support cushion lying on the adjustable base can then be easily manipulated. Thus, the retainer bar assemblies of the present invention allow a user to obtain the benefits of a bed assembly with an adjustable base without the difficulty that is frequently encountered in manipulating a mattress around a rigid retainer bar in order to change the sheets or otherwise move a portion of the mattress.

[0013] Referring first to FIGS. 1-2, in one exemplary embodiment of the present invention, a retainer bar assembly 17 is provided as part of a bed assembly 10 that further includes an adjustable base 12 and a support cushion in the form of a mattress 14. The mattress 14 rests on an upper surface 13 of the adjustable base 12 and includes a body supporting portion 15 and an optional comfort layer 16. The body supporting portion 15 of the mattress 14 is generally comprised of a flexible foam having a density suitable for distributing pressure from a user's body, or portion thereof, across the body supporting portion 15 of the mattress 14. Such flexible foams include, but are not limited to: latex foam: reticulated or non-reticulated visco-elastic foam (sometimes referred to as memory foam or low-resilience foam); reticulated or non-reticulated non-visco-elastic foam; high-resilience polyurethane foam: expanded polymer foams (e.g., expanded ethylene vinyl acetate, polypropylene, polystyrene, or polyethylene); and the like. In the exemplary embodiment shown in FIGS. 1-2, the body supporting portion 15 is comprised of a visco-elastic foam that has a low resilience, but sufficient hardness and density so that pressure is distributed evenly across the body supporting portion 15 of the mattress 14.

[0014] With respect to the hardness of the visco-elastic foams used in the body supporting portion 15, suitable visco-elastic foams for the body supporting portion 15 have a hardness of at least about 10 N to no greater than about 80 N. as measured by exerting pressure from a plate against a sample of the material to a compression of at least 40% of an original thickness of the material at approximately room temperature (i.e., 21°C to 23°C), where the 40% compression is held for a set period of time as established by the International Organization of Standardization (ISO) 2439 hardness measuring standard. In some embodiments, the visco-elastic foam that comprises the body supporting portion 15 has a hardness of about 10 N, about 20 N, about 30 N, about 40 N, about 50 N, about 60 N, about 70 N, or about 80 N to provide a desired degree of comfort and body-conforming qualities.

[0015] With respect to the density of the visco-elastic foams used in the body supporting portion 15, suitable visco-elastic foams for the body supporting portion 15 have a density that also assists in providing a desired degree of comfort and body-conforming qualities, as well as

an increased degree of material durability. In some embodiments, the density of the visco-elastic foam that comprises the body supporting portion 15 of the mattress 14 has a density of no less than about 30 kg/m³ to no greater than about 150 kg/m³. In some embodiments, the density of the visco-elastic foam that comprises the body supporting portion 15 of the mattress 14 is about 30 kg/m³, about 40 kg/m³, about 50 kg/m³, about 60 kg/m³, about 70 kg/m³, about 80 kg/m³, about 90 kg/m³, about 100 kg/m³, about 110 kg/m³, about 120 kg/m³, about 130 kg/m³, about 140 kg/m³, or about 150 kg/m³. Of course, the selection of a visco-elastic foam having a particular density will affect other characteristics of the foam, including its hardness the manner in which the foam responds to pressure, and the overall feel of the foam, but it should be appreciated that a visco-elastic foam having a desired density and hardness can readily be selected for a particular application or mattress assembly as desired.

[0016] Referring still to FIGS. 1-2, in this exemplary embodiment, the mattress 14 further includes an upper comfort layer 16 that is positioned atop the body supporting portion 15 and provides a level of comfort to a body of a user or a portion of thereof that is resting on the mattress 14. The comfort layer 16 is also preferably comprised of a visco-elastic foam. However, the comfort layer 16 typically has a density, hardness or both that is less than that of the body supporting portion 15 of the mattress 14, such that the comfort layer 16 provides a softer surface on which to rest the body of a user or a portion thereof. For example, in some embodiments, the mattress 14 includes a body supporting portion 15 that is comprised of visco-elastic foam with a density of about 80 kg/m³ and a hardness of about 13 N, while the comfort layer 16 is comprised of a visco-elastic foam with a density of about 35 kg/m³ and a hardness of about 10 N.

[0017] Regardless of the particular hardness and density of the materials (e.g., the foams) used, the body supporting portion 15 and the comfort layer 16 of the mattress 14 are preferably secured to one another to create an integrated mattress 14 and to prevent the body supporting portion 15 and the comfort layer 16 from unnecessarily moving relative to one another during use. Nevertheless, in creating such an integrated mattress 14, when the mattress 14 is placed on the adjustable base 12, and the base 12 is articulated, as shown in FIG. 2, the weight of the mattress 14, or a user lying on the mattress 14, will often cause the mattress 14 to slide downward across the upper surface 13 of the adjustable base 12. To prevent such movement of the mattress 14 relative to the adjustable base 12, the retainer bar assembly 17 is positioned at a lower end 11 of the upper surface 13 of the adjustable base 12 and includes a retainer bar 20 that is configured to secure the mattress 14 on the adjustable base 12 when the retainer bar 20 is in a lowered position, as shown in FIG. 1. Unlike the rigidly-attached retainer bar assemblies traditionally used with adjustable bases, however, the retainer bar 20 is configured such that the retainer bar 20 can be pulled upward and then rotated away from the mattress 14 lying on the adjustable base 12 to thereby allow a user to easily manipulate or otherwise move the mattress 14, such as, for example, to rotate the mattress 14 or change the sheets covering the mattress 14.

[0018] Referring now to FIGS. 1-3, to provide a retainer bar assembly 17 that can be moved in such a manner, the retainer bar 20 includes a horizontal rod 21 as well as two legs 22, 26.

Each of the legs 22, 26 includes an upright portion 23, 27, a curved lower portion 24, 28, and an end portion 25, 29 that extends in a direction substantially parallel to the horizontal rod 21. The two legs 22, 26 are connected to or are integral with the horizontal rod 21 and have a height that allows the horizontal rod 21 to rest against the body supporting portion 15 of the mattress 14 when the retainer bar 20 is in the lowered position, as described below.

[0019] Referring now to FIGS. 2-3 and 5-6, to secure the retainer bar 20 to the lower end 11 of the upper surface 13 of the adjustable base 12, the retainer bar 20 further includes a pair of brackets 30a, 30b. The brackets 30a, 30b are typically made of a sufficiently hard metal or plastic material to withstand the movement of the retainer bar 20 or a force being applied to the retainer bar 20 (e.g., as a result of the mattress pushing against the retainer bar 20 when the adjustable base 12 is articulated), and are attached to two support members 70a, 70b extending longitudinal along opposite sides of the adjustable base 12. One bracket 30a is attached to one support member 70a and the second bracket 30b attached to the other support member 70b on the opposite side of the adjustable base 12. Each of the brackets 30a, 30b, however, are identical to one another such that the brackets 30a, 30b can be used interchangeably on either of the support members 70a, 70b. Further, each bracket 30a, 30b defines a first channel 31a, 31b and a second channel 32a, 32b that are positioned on opposite sides of each bracket 30a, 30b. Such channels 31a, 31b, 32a, 32b are configured to receive the end portions 25, 29 of each of the two legs 22, 26. In this regard, each channel 31a, 31b, 32a, 32b includes a vertical segment 33a, 33b, 35a, 35b and an angled segment 34a, 34b, 36a, 36b, the importance of which is discussed below.

[0020] By providing channels 31a, 31b, 32a, 32b with both a vertical segment 33a, 33b, 35a, 35b and an angled segment 34a, 34b, 36a, 36b, each channel 31a, 31b, 32a, 32b is configured to allow the end portions 25, 29 of the two legs 22, 26 to be moved upward along the length of the vertical segments 33a, 33b, 35a, 35b and then along the length of the angled segments 34a, 34b, 36a, 36b to allow the retainer bar 20 to be rotated. More specifically by providing channels 31a, 31b, 32a, 32b that allow the end portions 25, 29 of the two legs 22, 26 to be moved in such a manner, when a user of the bed assembly 10 grabs the horizontal rod 21 of the retainer bar 20 and pulls upward, the end portions 25, 29 of the two legs 22, 26 are moved upward along the length of the vertical segments 33a, 33b, 35a, 35b, as best shown in FIG. 5. Then, at the user pulls back on the horizontal rod 21, the end portions 25, 29 of the two legs 22, 26 are moved along the length of the angled segments 34a, 34b, 36a, 36b to thereby rotate the horizontal rod 21 away from each bracket 30a, 30b and, consequently, rotate the horizontal rod 21 and the upright portion 23, 27 of the legs 22, 26 away from the mattress 14, as shown in FIGS. 2 and 6.

[0021] Referring again to FIGS. 1-3, to further secure the retainer bar 20 in each bracket 30a, 30b and prevent the disengagement of the end portions 25, 29 of the two legs 22, 26 of the retainer bar 20 from the channels 31a, 31b, 32a, 32b in the brackets 30a, 30b, as well as from the brackets 30a, 30b themselves, the retainer bar assembly 17 further includes caps 40a, 40b that cover the open tops 37a, 37b of each bracket 30a, 30b. Similar to the brackets 30a, 30b, the caps 40a, 40b, are preferably made of a sufficiently hard metal or plastic material to

withstand the movement of the retainer bar 20. As perhaps best shown in FIG. 3, each of the caps 40a, 40b defines a first slot 42a, 42b and a second slot 43a, 43b, which are substantially parallel to one another, and have a length that extends longitudinally along a top surface 41a, 41b of the caps 40a, 40b. In this regard, and also similar to the brackets 30a, 30b, each of the caps 40a, 40b are identical to one another such that the caps 40a, 40b can be used interchangeably with either of the brackets 30a, 30b or on either side of the adjustable base 12.

[0022] In the exemplary embodiment shown in FIGS. 1-3, to secure the retainer bar 20 in the brackets 30a, 30b, the end portion 25 of the leg 22 is placed in the channel 31a of the bracket 30a, and the end portion 29 of the other leg 26 is housed in the channel 32b of the second bracket 30b. As such, when the caps 40a, 40b are placed over the brackets, the leg 22 is housed within the first slot 42a of one cap 40a and the other leg 26 is housed within the second slot 43b of the other cap 40b. Thus, the caps 40a, 40b and, more particularly, the slots 42a, 43b, prevent the legs 22, 26 of retainer bar 20 from being pinched or otherwise pushed together and the end portions 25, 29 from becoming disengaged from the channels 31a, 32b as the retainer bar 20 is moved.

[0023] Referring now to FIGS. 3-4, to further secure the retainer bar 20 in the brackets 30a, 30b and, in particular, the end portions 25, 29 of the legs 22, 26 of the retainer bar 20, each cap 40a, 40b further comprises at least one fin that extends downwardly from the caps 40a, 40b and into each bracket 30a, 30b to secure the end portions 25, 29 of the legs 22, 26 in the channels 31a, 32b of each bracket 30a, 30b. In the exemplary embodiment shown in FIGS. 3-4, the caps 40a, 40b include a first fin 46a, 46b and a second fin 47a, 47b extending downwardly from the respective caps 40a, 40b such that, upon using the caps 40a, 40b to cover the open tops 37a, 37b of each bracket, the first fin 46a of one cap 40a extends into the bracket 30a adjacent to the first slot 42a and the second fin 47b of the other cap 40b extends into the other bracket 30b adjacent to the second slot 42b. Thus, the first fin 46a and the second fin 47b, respectively, secure the end portions 25, 29 of the legs 22, 26 in the first channel 31a of one bracket 30a and the second channel 32b of the other bracket 30b. Of course, it is also contemplated that other caps having fin configurations capable of securing the end portions 25, 29 in the channels 31a, 31b, 32a, 32b of the brackets 30a, 30b, including caps having a single unitary fin, can also be used.

[0024] With further respect to the caps 40a, 40b of the exemplary retainer bar assembly 17 of the present invention, each cap 40a, 40b also generally includes a lip 44a, 44b that can be placed under corresponding rims 38a, 38b of each bracket 30a, 30b to prevent the caps from being pulled off each bracket 30a, 30b and to thereby secure the caps 40a, 40b to each bracket 30a, 30b. To also secure the caps 40a, 40b to the brackets 30a, 30b, each cap 40a, 40b additionally defines an opening 45a, 45b for inserting a fastener, such as the screws 50a, 50b shown in FIG. 3, through each cap 40a, 40b. In such embodiments, once the particular screw 50a, 50b has been inserted through the particular opening 45a, 45b in the cap 40a, 40b, the particular screw 50a, 50b can then be inserted in a corresponding bore 39a, 39b in each bracket 30a, 30b to thereby further secure each cap 40a, 40b and prevent the caps 40a, 40b

and the retainer bar 20 from being pulled from the adjustable base 12 as the horizontal rod 21 is being pulled upward and rotated away from the brackets 30a. 30b.

[0025] As an additional refinement to the caps 40a, 40b used in the retainer bar assembly 17 of the present invention, and referring now to FIGS. 2-3, each of the slots 42a, 42b, 43a, 43b of the caps 40a, 40b further include open ends 48a, 48b, 49a, 49b that arc adjacent to the upper edge 18 of the foot board 19 of the adjustable base 12. In this regard, when the horizontal rod 21 is pulled upward and the lower curved portion 24, 28 of the legs 22, 26 of the retainer bar 20 is slid over the rounded surface 51a, 51b of each bracket, the legs 22, 26 extend along the length of the slots 42a, 43b and the two legs 22, 26 are rotated against the upper edge 18 of the foot board 19 of the adjustable base 12 to allow a user to more fully rotate the retainer bar 20 away from the mattress 14 and thereby allow the mattress 14 to then be easily manipulated.

[0026] One of ordinary skill in the art will recognize that additional embodiments or implementations are possible without departing from the the scope of the claims which follow. This detailed description, and particularly the specific details of the exemplary embodiments and implementations disclosed herein, is given primarily for clarity of understanding, and no unnecessary limitations are to be understood therefrom, for modifications will become obvious to those skilled in the art upon reading this disclosure and may be made without departing from the scope of the claimed invention.

REFERENCES CITED IN THE DESCRIPTION

This list of references cited by the applicant is for the reader's convenience only. It does not form part of the European patent document. Even though great care has been taken in compiling the references, errors or omissions cannot be excluded and the EPO disclaims all liability in this regard.

Patent documents cited in the description

- [JP61165664U \[0001\]](#)

PATENTKRAV

1. Holdestanganordning (17) til anvendelse sammen med en justerbar basis (12) for en støttepude (14), omfattende:

5

En holdestang (20), konfigureret til at fastgøre støttepuden (14) på den justerbare basis (12), hvilken holdestang (20) omfatter en horisontal stang (21) samt to ben (22, 26), der er forbundet til den horisontale stang (21), hvorved hvert af de to ben (22, 26) omfatter et endefsnit (25, 29), som strækker sig derfra i en retning, der stort set er parallel med den horisontale stang (21); og

10

to konsoller (30a, 30b), hvorved hver konsol definerer mindst én kanal (31a, 31b) til modtagelse af endefsnittet (25, 29) af hvert af de to ben (22, 26), og hver kanal (31a, 31b) omfatter et vertikalt segment (33a, 33b, 35a, 35b) samt et vinklet segment (34a, 34b, 36a, 36b), således at hver kanal (31a, 31b) er konfigureret til at muliggøre bevægelse af den horisontale stang (21) opad og drejning bort fra hver konsol (30a, 30b),

15

kendetegnet ved, at

20

en hætte (40a, 40b) til dækning af en åben overside (37a, 37b) for hver konsol (30a, 30b).

2. Holdestanganordning ifølge krav 1, hvorved hvert af de to ben (22, 26) ydermere omfatter et opretstående afsnit (23, 27) samt et nedre, krumt afsnit (24, 28), der er konfigureret til at glide over en afrundet flade på hver konsol (30a, 30b), når den horisontale stang 21 drejes bort fra hver konsol (30a, 30b).

25

3. Holdestanganordning ifølge krav 1, hvorved hver konsol (30a, 30b) definerer en første kanal (31a, 31b) og en anden kanal (32a, 32b), hvorved den første kanal og den anden kanal er positioneret på modstående sider af hver konsol (30a, 30b).

30

4. Holdestanganordning ifølge krav 1, hvorved hætten (40a, 40b) definerer mindst en slids (42a, 42b) med en længde, og som strækker sig i længderetning

gen langs en overside af hættten (40a, 40b), således at et respektivt ben (22, 26) bevæger sig langs længdeudstrækningen af slidsen (42a, 42b), når den horisontale stang (21) drejes bort fra hver konsol (30a, 30b).

5 5. Holdestanganordning ifølge krav 4, hvorved hættten (40a, 40b) definerer en første slids (42a) og en anden slids (42b), som i det væsentlige er indbyrdes parallelle.

6. Holdestanganordning ifølge krav 5, hvorved det ene af holdestangens (20) to
10 ben (22, 26) huses i den første slids (42a) i den ene hætte (40a), og det andet af holdestangens (20) to ben (22, 26) huses i den anden slids (42b) i en anden hætte (40b).

7. Holdestanganordning ifølge krav 1, hvorved hættten (40a, 40b) omfatter en
15 læbe (44, 44b) til fastgørelse af hættten (40a, 40b) til en dertil svarende rand på hver konsol (30a, 30b).

8. Holdestanganordning ifølge krav 1, hvorved hættten (40a, 40b) omfatter en
20 ribbe (46a, 46b, 47a, 47b), der strækker sig nedad fra hættten (40a, 40b), således at ribben (46a, 46b, 47a, 47b), ved anvendelse af kappen (40a, 40b) til dækning af den åbne overside af hver holder (30a, 30b), strækker sig ind i hver konsol (30a, 30b) og fastgør et respektivt bens (22, 26) endeafsnit i en respektiv kanal i en respektiv konsol (30a, 30b).

25 9. Holdestanganordning ifølge krav 5, hvorved hver konsol (30a, 30b) definerer en første kanal (31a, 31b) samt en anden kanal (32a, 32b), hvorved den første kanal (31a, 31b) og den anden kanal (32a, 32b) er positioneret på modstående sider af hver kanal (30a, 30b),

og

30 hvorved hættten (40a, 40b) ydermere omfatter en første ribbe (46a, 46b) samt en anden ribbe (47a, 47b), der strækker sig nedad fra hættten (40a, 40b), således at, ved anvendelse af hættten til dækning af den respektive konsols (30a, 30b) åbne overside, den første ribbe (46a, 46b) strækker sig ind i hver konsol

(40a, 40b), grænsende op til den første slids (42a), og den anden ribbe (47a, 47b) strækker sig ind i hver konsol (40a, 40b), grænsende op til den anden slids (42b) med henblik på at fastgøre et respektivt bens (21, 26) endeafsnit i enten den første kanal (31a, 31b) eller den anden kanal (32a, 32b).

DRAWINGS

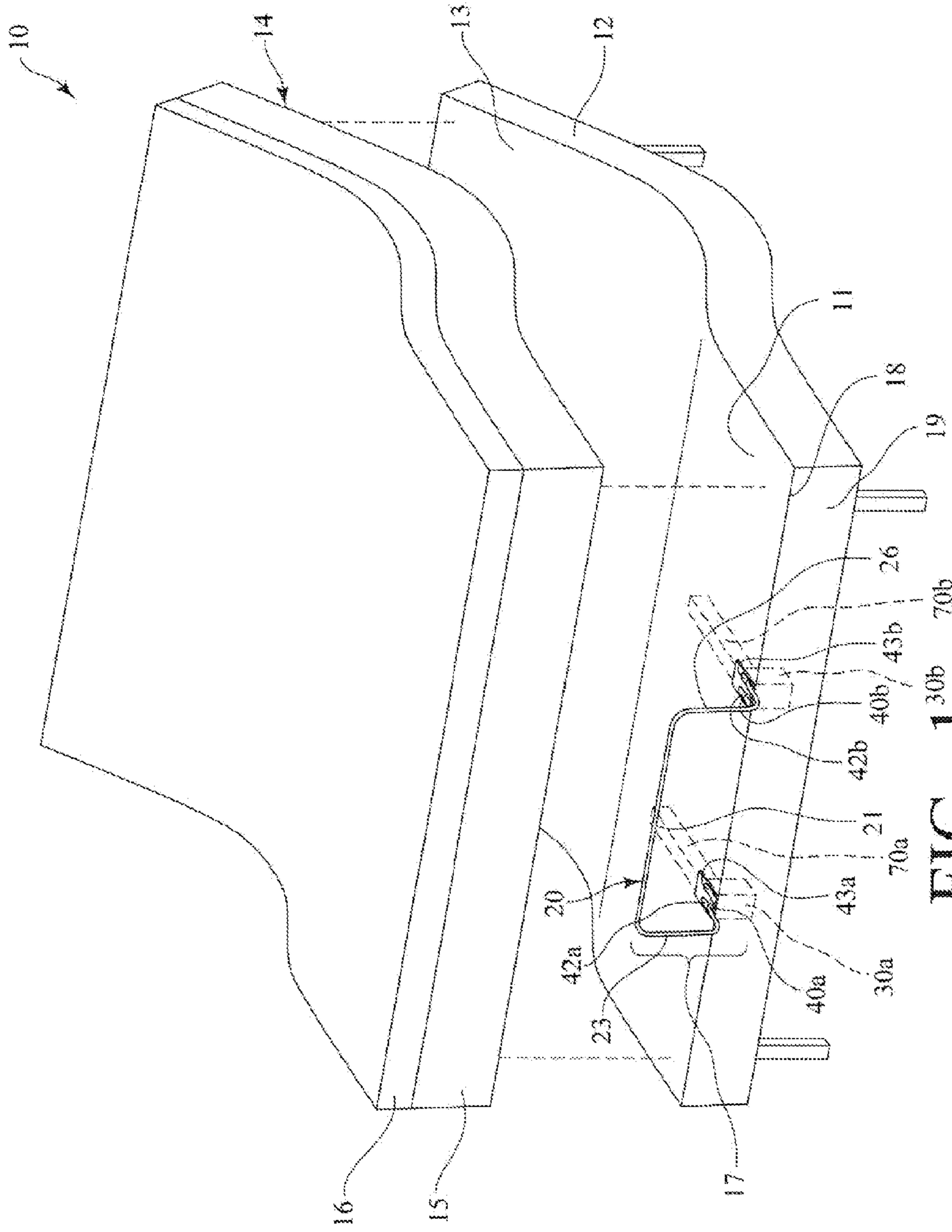

FIG. 1

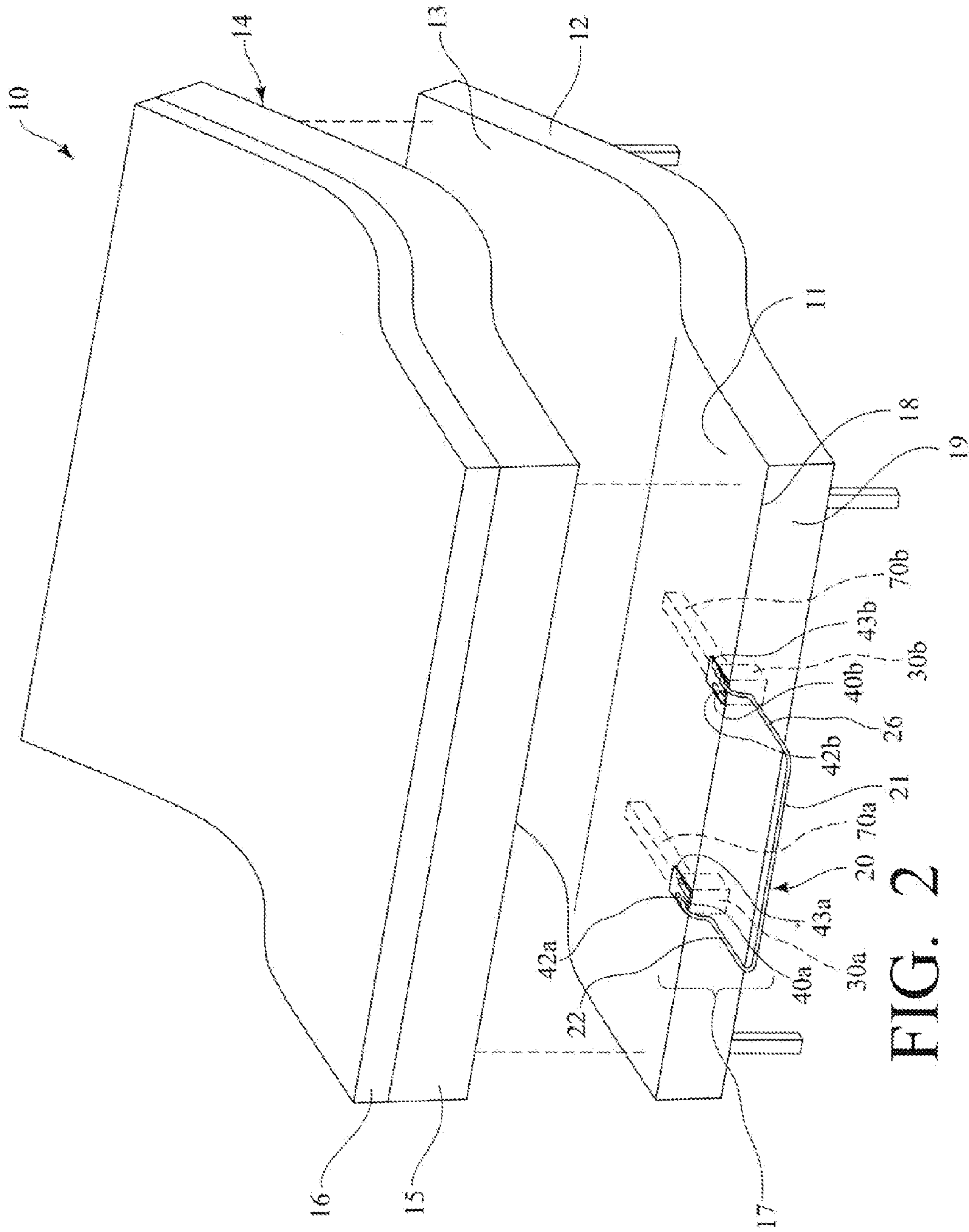

FIG. 2

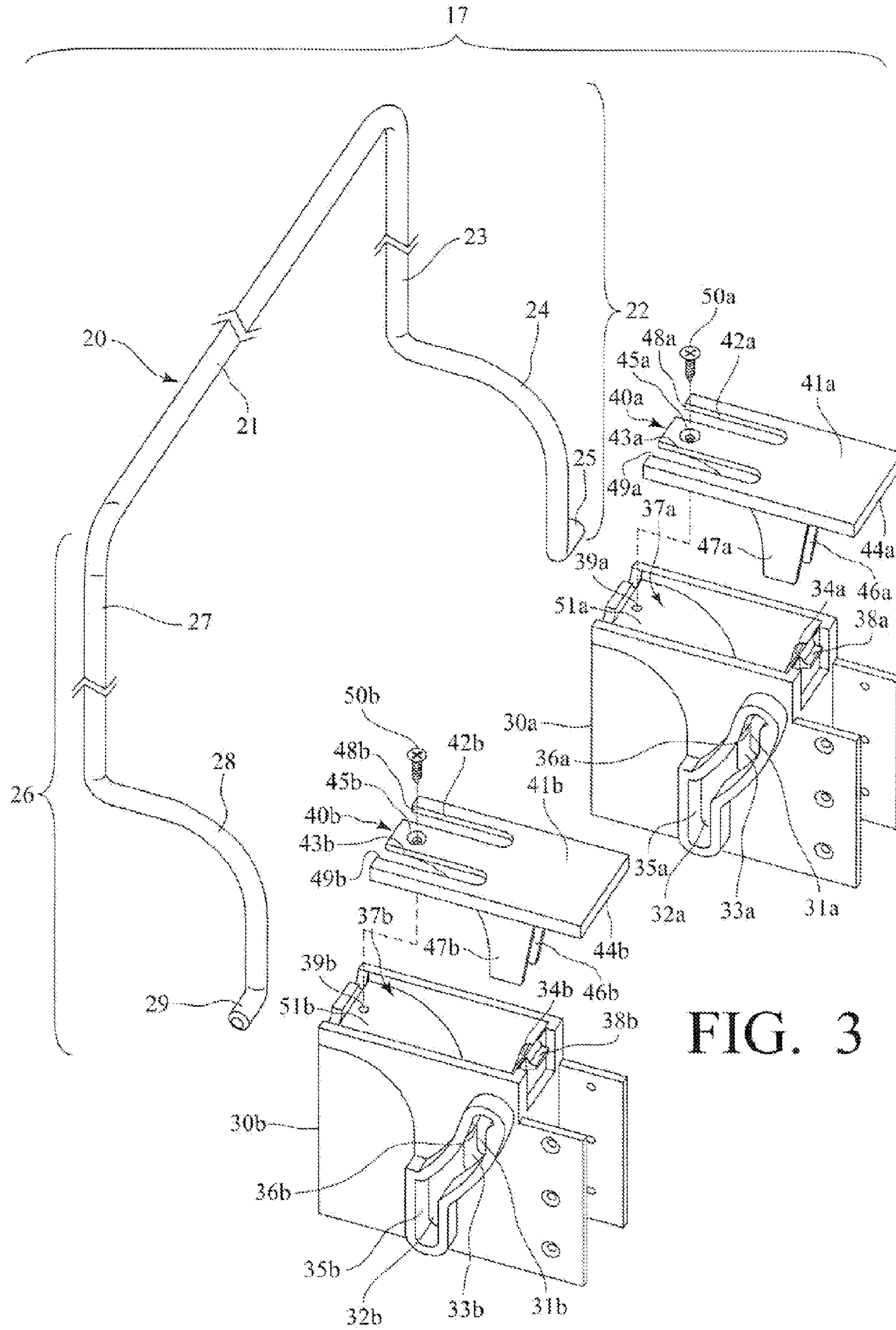
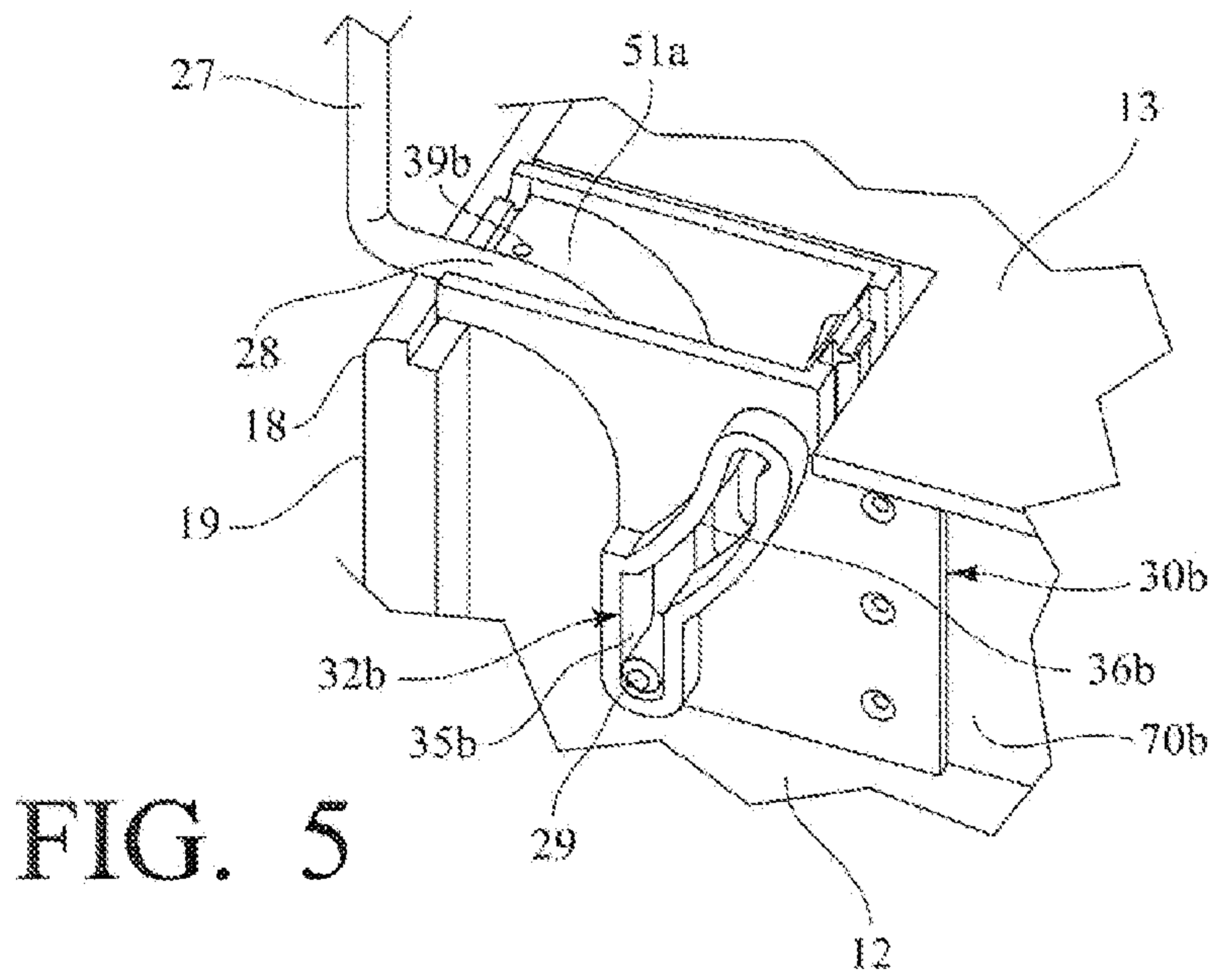
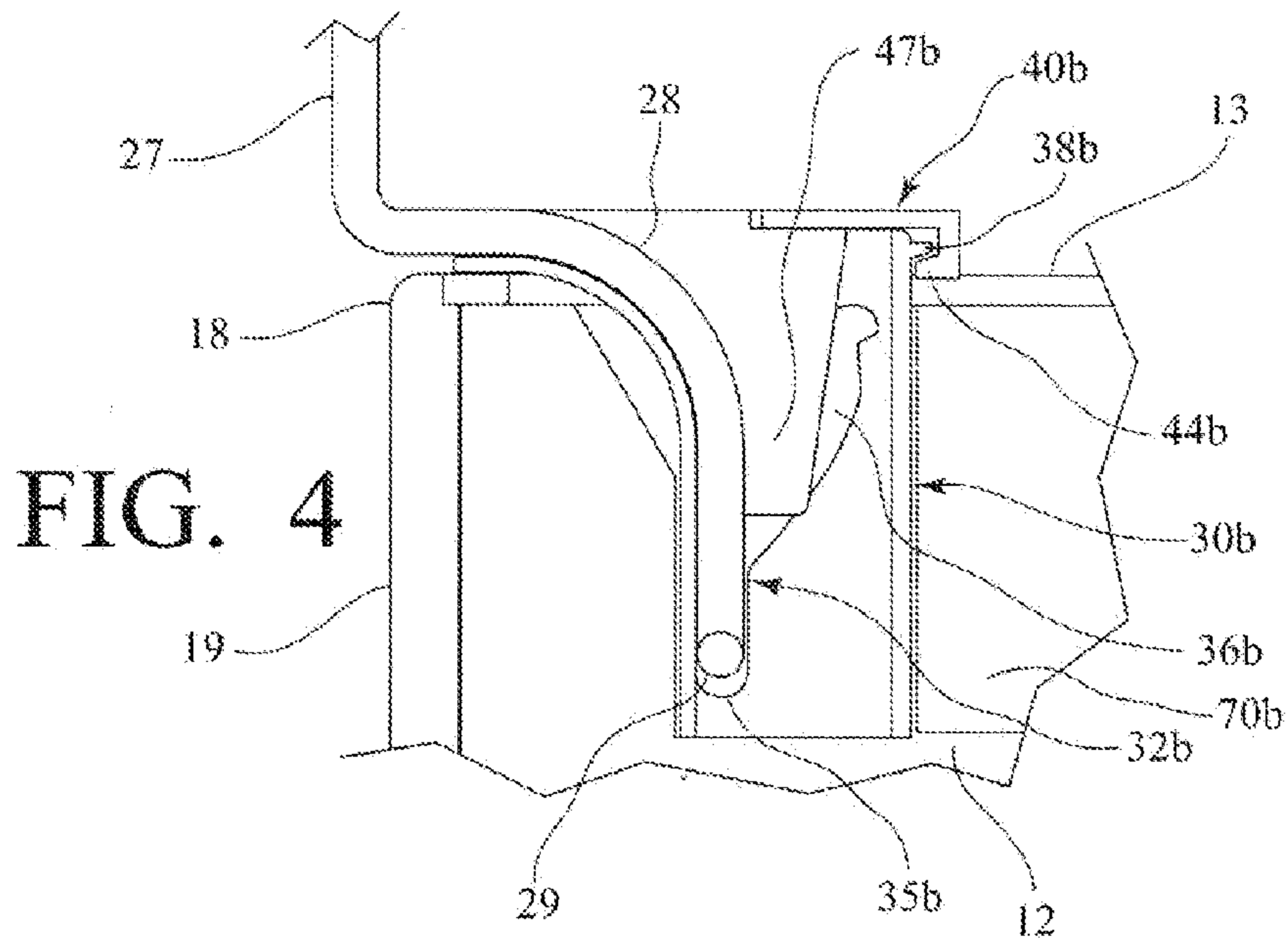

FIG. 3



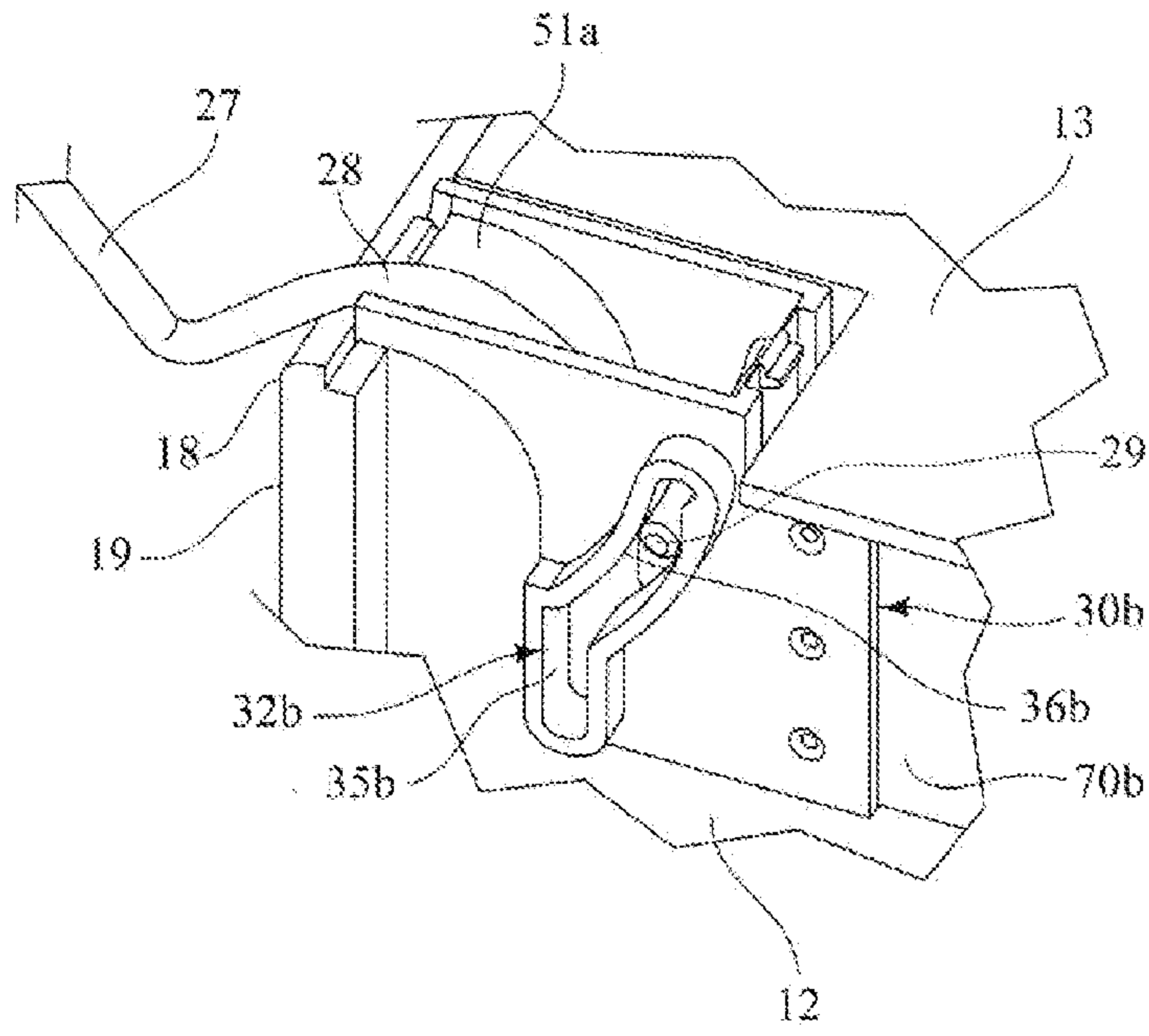

FIG. 6