

April 1, 1924.

1,488,532

T. D. DOUGLASS

PIVOT SUPPORT FOR PICKER STICKS

Filed Aug. 26, 1922

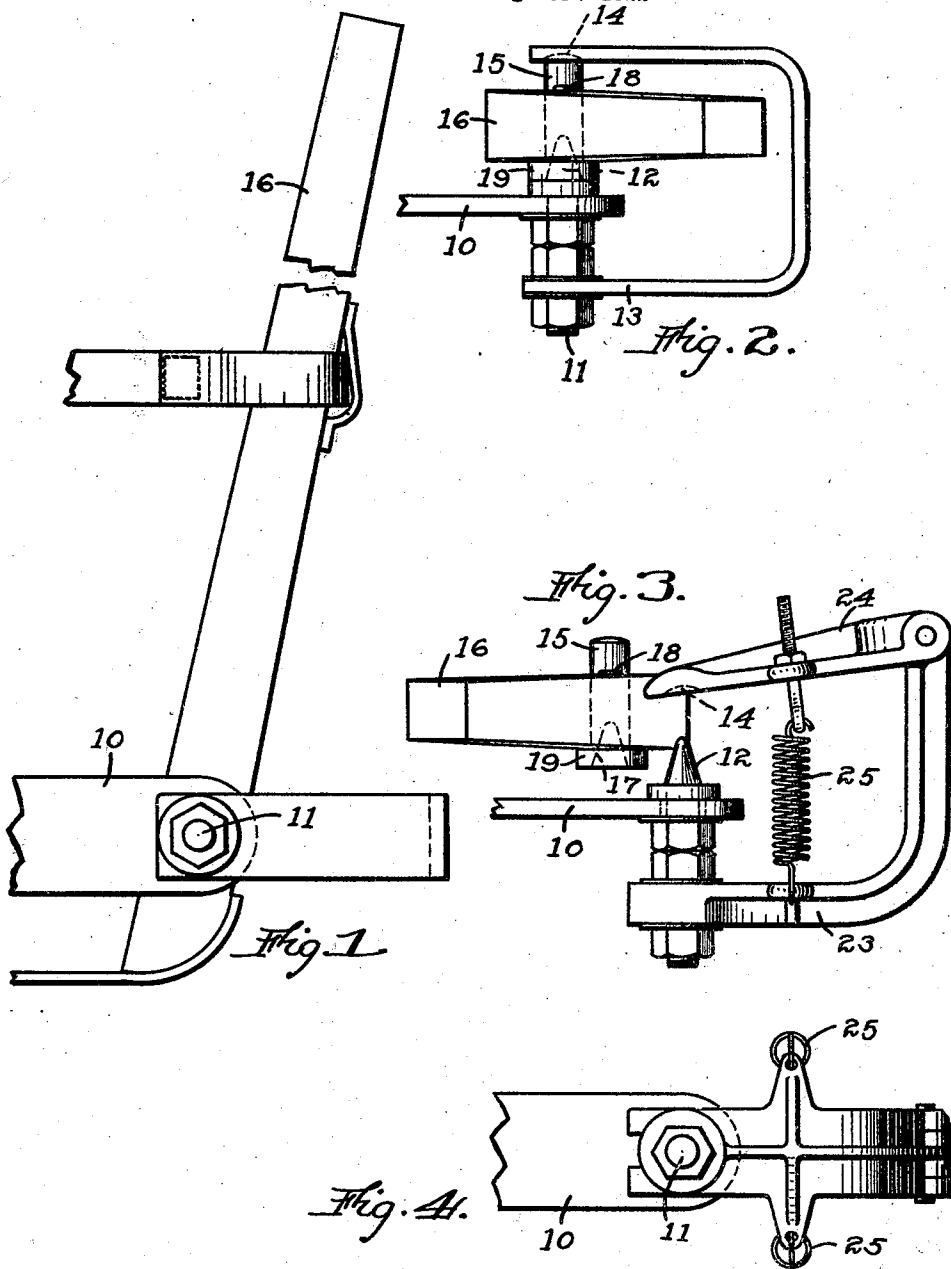

Inventor
Thomas D. Douglass
By Attorneys.

Southgate & Southgate

UNITED STATES PATENT OFFICE.

THOMAS D. DOUGLASS, OF AUBURN, MASSACHUSETTS.

PIVOT SUPPORT FOR PICKER STICKS.

Application filed August 26, 1922. Serial No. 584,548.

To all whom it may concern:

Be it known that I, THOMAS D. DOUGLASS, a citizen of the United States, residing at Auburn, in the county of Worcester and State of Massachusetts, have invented a new and useful Pivot Support for Picker Sticks, of which the following is a specification.

This invention relates to a support on which a picker stick for a loom is adapted to be pivotally carried.

The principal object of the invention is to provide an effective pivotal support for the picker stick which under ordinary operation will hold it accurately and support it firmly, but which, when the picker stick meets an obstruction that would tend to force it to one side, will yield and allow the stick to become automatically disconnected. The invention also involves the construction of such an automatically detachable pivotal support in a simple and practical form which will be suitable for use on looms of various kinds.

Further objects and advantages of the invention will appear hereinafter.

Reference is to be had to the accompanying drawings, in which—

Fig. 1 is a side view of a picker stick mounted in accordance with this invention;

Fig. 2 is a plan of the supporting pivot for the stick and connected parts;

Fig. 3 is a similar view showing a modification, and

Fig. 4 is a side view of the same.

It is well understood that the picker stick is a very expensive part of a loom. Although made carefully and of the best materials they last only a very short time because whenever a shuttle is caught in a box or any other obstruction appears, the picker stick strikes a hard blow against an unyielding surface and is deflected to one side or the other very often so that it is twisted and split. They have to be replaced so often that the cost of the picker sticks constitutes a very important item in the operation of a loom room. Of course, added to that also is the cost of labor in making the replacements. Furthermore, when the picker stick does not break, often the sweep stick is broken or the gears stripped. Now that individual motors are being used for the looms more and more, this condition becomes worse as the motor cannot give even as much as the old belt transmission, result-

ing in the burning out of the armature or the blowing of fuses.

This invention is designed for the purpose of providing means whereby when such an action happens the picker stick, instead of resisting the obstruction, will become automatically detached from its bearing so that the stick will not be broken, but simply moved over out of place without injuring it. The only thing that has to be done is to slip it back in place and I have provided means whereby this can be done very expeditiously and therefore without much expense.

Referring first to Figs. 1 and 2, I have shown a supporting lug or projection 10 on the loom as provided with a perforation through which extends a bolt 11, which bolt is provided with a flat side so that it cannot turn in the hole in the lug 10 which is also of the same shape. This bolt is fastened in position by nuts and the like and constitutes a stationary part of the device. On the end of it it is provided with a cylindrical head having a conical projection 12 rounded on its extreme end and having a gradual taper.

Fastened securely on this bolt is the end of a spring frame 13. In this form I have shown this frame itself consisting of a piece of spring metal. It is of U-shaped construction and provided at the free end with a concave depression 14 exactly opposite, and centrally in alignment with, the conical projection 12.

These two elements 12 and 14 are employed for supporting a pivot stud 15 on which the picker stick 16 is pivotally mounted. One end of the pivot stud has a conical socket 17 fitting the projection 12. The other end of this pivot stud is rounded to fit a depression or socket 14 in the opposite arm of the frame 13 and of the same size and shape as the end of the stud and adapted to fit thereon. A cotter pin 18 is shown for holding the picker stick up against the head 19 on the end of the pivot stud 15.

The picker stick is free to swing on the pivot stud 15 and does not turn with it. It operates in the usual way in accordance with the loom on which it is placed, and its operation need not be described. However, it is obvious that the spring resistance of the frame 13 holds the pivot stud 15 cen-

trally in its proper position and that there is no positive means for holding it. Now when the picker stick moves toward the loom and meets with an obstruction, such as it is likely to in its ordinary operation, and is thereby given a slight turn or twist in either direction, the spring of the frame 13 will yield and allow the pivot stud 15 to be released at its outer end. The picker stick and stud then will be automatically detached from the rest of the device, the conical socket at 17 also becoming disengaged from the conical projection 12. In this way the picker stick, instead of resisting the opposition to which it is subjected, will simply yield to it. The only effect will be to throw the stick out of position on the loom. When these things happen the attendant or loom fixer has to come to the loom to make certain changes or replacements any way, and when he is doing it he can replace the picker stick by moving the end of the spring frame 13 out and replacing the stud 15 with the picker stud on it in the position shown in the drawings. This is a repair job that can be done without loss of any material amount of time and will be done accurately because there is only one place in which the stud and stick can be put.

In Figs. 3 and 4 I have shown a modification in which a solid yielding metal frame 23 is provided having a lever 24 freely pivoted thereon. This lever is adjustably connected by two springs 25 with the fixed frame 23 and holds the socket 17 in the same way as described above. The parts will operate in just the same way in all respects.

With this device, the life of each picker stick is very materially extended and the cost of replacement is reduced to a minimum. Also the time required for taking out an old stick and putting in a new one and connecting the new one with the associated parts as well as disconnecting the old one is entirely saved. The actual replacement is also instantaneous, and there is no danger of getting the parts back in the wrong position. This goes a long way towards fully solving the problem caused by the frequent breakage of picker sticks that has been a serious element in the operation of looms for a great many years.

Although I have illustrated and described only two forms of the invention I am aware of the fact that other modifications can be made therein without departing from the scope of the invention as expressed in the claims.

Therefore, I do not wish to be limited to the details of construction herein shown and described, but what I do claim is:—

1. In a pivot support for a picker stick, the combination of a support mounted in stationary position on the frame of a loom, a pivot stud for the picker stick having a

detachable connection with said support at one end, and yielding means for holding the other end of said stud, whereby in case of serious obstruction to the action of the picker stick the yielding means will be stretched and the stud released and detached thereby relieving the picker stick from all strain and instantaneously and automatically.

2. In a picker stick support, the combination of a supporting member adapted to be fixed in stationary position having a projection on its end, a pivot stud provided with a socket in its end adapted to fit on said projection, an arm for holding the opposite end of said stud, said arm being movable away from the stud to relieve it, and yielding means for holding said arm firmly but yieldingly against the stud in normal operation capable of yielding sufficiently under excessive strain to release the stud and picker stick.

3. In a supporting device for a picker stick, the combination of a support adapted to be mounted in stationary position on a loom frame and having a conical projection on the end thereof, a pivot stud for the picker stick having a conical depression fitting on said projection and constituting detachable means for supporting that end of the stud, yielding means for forcing the stud into a position in which the two conical surfaces are in intimate contact and holding the stud in a position to support the picker stick, whereby when the picker stick meets serious opposition the yielding means will yield and the stud will become disengaged instantaneously and automatically.

4. In a loom, the combination with a picker stick, of a pivot stud therefor on which the picker stick is adapted to swing, and detachable means for supporting said stud at both ends, the means at one end being yieldably mounted and movable substantially longitudinally away from the end of the stud, whereby when the picker stick meets an obstruction said yielding means will disengage the stud and the picker stick will be released to relieve the strain and prevent the breaking of the stick.

5. In a device of the character described, the combination of a pivot stud having a conical depression in one end, a conical pin adapted to engage in said depression and hold and center it, an arm adapted to engage the other end of the pivot stud, and yielding means for supporting said arm arranged to constantly apply yielding pressure on the end of the pivot stud to hold the stud on the conical pin but capable of yielding far enough to allow the stud to be disengaged from the conical pin in case of meeting an obstruction.

6. In a detachable connection, the combination with a stud, of a fixed support therefor, the stud and support having a conical

projection and depression fitting each other to hold and center that end of the stud, an arm at the other end of the stud having means for engaging, centering and holding the other end of the stud, and yielding means connecting the arm with the fixed support for holding the arm yieldingly against the end of the stud and capable of yielding sufficiently to permit the stud to be entirely detached from the support and arm when subjected to sufficient force.

7. In a detachable connection, the combination of a support having a conical end,

a stud having a conical depression in the end fitting thereon, a transverse arm having a depression in the side thereof fitting the other end of the stud and holding it, said arm having an integral spring fixed at the other end on said support adapted to hold the stud in position on the pin until sufficient pressure is applied to detach the stud from the arm and the pin.

In testimony whereof I have hereunto affixed my signature.

THOMAS D. DOUGLASS.