

- 1 -

DEVICE FOR TRANSFERRING FLUIDS FROM A CARTRIDGE TO A CONTAINER

FIELD OF THE INVENTION

The present invention relates to a transfer device and more particularly, relates to a transfer device suitable for transferring fluid contents from a first cartridge to a second container.

BACKGROUND OF THE INVENTION

In the pharmaceutical field, medicants can be packaged in a first type of container and need to be transferred to a second type of container. The reason could be that the second type of container is a specialized one which is difficult to fill on known production lines. A second situation can arise when it is desired to transfer a fluid into a second container which may contain a second drug component which is to be mixed with the first fluid. In this regard, reference may be had to PCT Application CA2005/001839, the teachings of which are hereby incorporated by reference.

SUMMARY OF THE INVENTION

It is an object of the present invention to provide a system for transferring a fluid from a first container to a second container.

It is a further object of the present invention to provide a system for transferring a fluid from a first container to a second container in a sterile environment.

It is a further object of the present invention to provide a system for transferring a fluid from a first container to a second container while eliminating substantially all air or other gas in the second container.

According to one aspect of the present invention, there is provided a system for

- 2 -

transferring a fluid, the system comprising a housing, a first container having a fluid therein, the first container having an open top, the open top being sealed by a septum, a piston located within the first container, the piston and the septum defining a compartment having the fluid, a second container, the second container having a body, a cavity within the body, an open top and an open bottom, the open top being sealed by a pierceable septum, a plunger within the cavity, the plunger being located proximate the septum so as to minimize any air between the pierceable septum and the plunger, the first container and the second container being located within the housing at opposite ends thereof, a moveable needle shuttle, the needle shuttle having first and second piercing ends and having a fluid passageway extending between the piercing ends, the arrangement being such that a first one of the piercing ends is adapted to initially pierce the plunger of the second container, and a second one of the piercing ends being designed to pierce the septum of the first container when one of the containers is moved towards the other of the containers to contact the piercing ends.

According to a further aspect of the present invention there is provided a method for transferring a fluid from a first container to a second container, the first container having an open top sealed by a septum, a piston located within the first container, the piston and the septum defining a compartment having the fluid therein, the second container having a body, a cavity within the body, an open top and an open bottom, the open top being sealed by a pierceable septum, a plunger within the cavity, the plunger being located proximate the septum so as to minimize any air between the septum and the plunger, comprising the steps of supplying a housing having a moveable shuttle therein, the shuttle having first and second piercing members located at either end thereof with a fluid passageway extending between the first and second piercing ends, placing the second container within the housing, placing

- 3 -

said first container having the fluid therein within the housing, advancing one of the containers to cause the piercing members to pierce the plunger of the second container and the pierceable septum of the first container, exerting pressure on a first container piston to cause the fluid to pass from the first container through the fluid passageway into the second container and cause the plunger to move rearwardly towards the open bottom.

According to a still further aspect of the present invention there is provided a system for transferring a fluid, the system comprising a housing, a first container having a fluid therein, the first container having an open top, a septum sealing the open top, a second container, the second container having a body, a cavity within the body, an open top and an open bottom, the open top being sealed by a pierceable septum, and a plunger within the cavity for sealing the open bottom, a vent from within the second container to the exterior thereof, a hydrophobic membrane sealing the vent, the first and second containers being mounted at opposite ends of the housing, a moveable needle shuttle mounted in the housing intermediate the first and second containers, the needle shuttle having first and second piercing ends, a fluid passageway extending between the first and second piercing ends.

According to a still further aspect of the present invention there is provided a method for transferring fluid from a first container to a second container, the method comprising the steps of supplying a first container having a fluid therein, the first container having an open end sealed by a pierceable septum, a second container for receiving the fluid to be transferred thereto, the second container having a body, a cavity within the body, an open top and an open bottom, the open top being sealed by a pierceable septum, a plunger sealing the open bottom, a vent extending from the cavity to the exterior of the container, a

- 4 -

hydrophobic membrane mounted in the vent, a needle shuttle having first and second piercing ends with a fluid passageway extending between the first and second piercing ends, placing the first container within the housing at one end thereof, placing the second container in the housing at a second end thereof, advancing the first container so as to cause the needle shuttle to advance towards the second container and thereby cause the second piercing end to pierce the plunger of the second container, and cause the first piercing end to pierce the septum of the first container, and exerting a pressure on the piston to cause the fluid to be advanced to the second container and to expel substantially all the air therefrom through the vent and the hydrophobic membrane.

According to a still further aspect of the present invention there is provided a system for transferring a fluid, the system comprising, a housing, a first container having a fluid therein, the first container having an open top and an open bottom, the open top being sealed by a septum and the open bottom being sealed by a piston, a second container, the second container having a body, a cavity within the body, an open top and an open bottom, the open top being sealed by a pierceable septum, a plunger within the cavity sealing the open bottom, the first container and the second container being located within the housing at opposite ends thereof, a moveable needle shuttle, the needle shuttle having first and second piercing ends and having a fluid passageway extending between the piercing ends, a pusher mechanism located rearwardly of the first container, the pusher mechanism having a first pushing element and a second pushing element, the first pushing element being designed to push the body of the first container, the second pushing element being designed to push the piston, the arrangement being such that upon an initial pushing movement, the first pushing element contacts the body to advance the first container and means to then permit the second

pusher element to exert pressure on the piston.

According to a still further aspect of the present invention there is provided a system for transferring a fluid from a first container to a second container, the system comprising an upper housing, the upper housing having an open top and an open bottom, the open top being designed to receive the second container, the second container having a body, a cavity within the body, an open top and an open bottom, the open top of the second container being sealed by a pierceable septum, a plunger within the cavity, the plunger being located proximate the septum so as to minimize any air between the septum and the plunger, a vent extending between the cavity and exterior of the body, a hydrophobic membrane sealing the vent, a lower housing, the lower housing having an open top and an open bottom, the open bottom being designed to receive said first container, a needle hub mounted intermediate the first and second containers, the needle hub having a cannula with first and second piercing ends, a fluid passageway extending between the first and second ends, a sheath extending about the first piercing end, the sheath being attached to the needle hub, and sealing means extending between an outer wall of the needle hub and an adjacent wall.

As used herein, the terms piston, plunger and septum all refer to a member which is pierceable by a needle or other piercing member. Generally, the term septum will denote a member about the mouth of the container while a piston or a plunger will refer to a member which is moveable within the body of the container.

Also, as used herein, the term distal will generally refer to that end of an element or member which is at a dispensing end while the term proximal will refer to that end from which the fluid is being moved.

In one embodiment of the invention, the fluid is to be transferred from a first

- 6 -

container which is a standard pharmaceutical container such as a cartridge which is designed to be filled on conventional filling lines. The second container will generally be one which is not fillable or difficult to fill on a standard pharmaceutical filling line. However, as previously mentioned, the system and method of the present invention could also be used to transfer a fluid into a second container which may contain a second drug component which is to be mixed with the first fluid.

In a first embodiment of the invention, the second container is supplied to the transfer device with the plunger thereof being located proximate the septum covering the mouth of the container. The container is then filled through the plunger and thus the amount of air in the container is minimized. The first container may typically be a syringe body and the shuttle or needle hub carries a cannula having two separate piercing ends, one designed to pierce the septum of the first container and the second designed to pierce the plunger of the second container.

The order of the piercing may vary. Thus, one may utilize an arrangement wherein a force exerted on the body of the first container will cause the needle hub or shuttle to advance such that the second piercing end will pierce the plunger of the second container followed sequentially by piercing of the septum of the first container. Alternatively, using special means so as not to pressurize the fluid in the first container, the septum of the first container may be initially pierced followed by piercing of the plunger of the second container.

In one of the embodiments of the present invention, various sealing means are employed in order to maintain sterility during the transfer operation.

BRIEF DESCRIPTION OF THE DRAWINGS

Having thus generally described the invention, reference will be made to the accompanying drawings illustrating embodiments thereof, in which:

Figures 1 to 5 are side sectional views of a first embodiment illustrating operation of a transfer device for transferring fluid contents from a first cartridge to a second container;

Figures 6 to 10 are side sectional views illustrating a further embodiment of a transfer device according to the present invention;

Figures 11 to 14 are side sectional views illustrating a third embodiment of a transfer device according to the present invention.

Figures 15A to 15G are side sectional views of a further embodiment of the present invention providing sealing means to prevent contamination and enhance sterility;

Figure 16 is a side sectional view of a further arrangement for enhancing sterility;

Figure 17 is a side sectional view illustrating an embodiment using a plurality of sealing means;

Figures 18 to 20 are side sectional views of further embodiments of a device having sealing means associated therewith.

DETAILED DESCRIPTION OF THE INVENTION

Referring to the drawings in greater detail and by reference characters thereto, there is illustrated in Figure 1 a transfer device generally designated by reference numeral 110.

Transfer device 110 includes a conventional fluid containing cartridge 112, a container 114 to which the fluid is to be transferred to, and a shuttle 116.

Cartridge 112 has a cylindrical body 120 and may have any suitable dimensions. In the illustrated embodiment, it is of an elongated configuration with a piston 122 being

located at one end thereof. At the other end, there is provided a pierceable septum 124 while the cylindrical body 120 contains a fluid 126 which is to be transferred to container 114.

Container 114 has an outer wall 128 which defines a cylindrical container configuration with a pierceable plunger 130 being located at one end thereof. A pierceable septum 132 is located at the other end.

Shuttle 116 includes a main body portion 136 with legs 138 extending from one end thereof. In the illustrated embodiment, there are provided two such legs 138. Each leg 138 has at the end thereof a flange 140 which extends diagonally outwardly.

Extending through main body portion 136 is a cannula which has a first piercing tip 144 located at one end thereof and a second piercing tip 146 located at the other end. If desired, sheaths may be placed about one or both of the exposed ends of the piercing tips.

Transfer device 110 also includes an outer housing 150. On the interior wall of housing 150 there is provided a shoulder 152 wherein the wall becomes of a diminished thickness. At the end having a diminished thickness, there are provided moveable biasing elements 154. Housing 150 also includes a threaded portion 156 designed to receive a cap 158.

As shown in Figure 1, cartridge 112 is loaded into transfer device 110. Subsequently, and as illustrated in Figure 2A, continued movement of cartridge 112 will cause movement of shuttle 116 due to the engagement of legs 138 on the shoulder of the cartridge 112. This in turn will lead to the piercing of plunger 130 by pierceable tip 144 of the cannula.

As may be seen in Figure 2B, continued movement of the shuttle will cause plunger 130 to advance and empty container 114 of air or other gaseous material therein. Still

further movement of cartridge 112 will then cause pierceable tip 146 of the cannula to pierce septum 124 of cartridge 112. It is to be noted that container 114 is not able to move due to engagement of biasing elements 154 with the shoulder thereof. As seen in Figure 2C, the piercing of septum 124 of cartridge 112 is achieved by legs 138 passing from the thicker part of housing 150 past shoulder 152 to thereby permit the movement of cartridge 112.

As illustrated in Figure 3, cap 158 is then indexed and elements 154 move outwardly to engage cap 158 and to permit advancement of container 114. Moveable elements 154, in other words, are retained by cap 158 and as soon as the cap is indexed or moved upwardly, they are biased outwardly. Any suitable arrangement such as a flexible tab may be utilized.

A piston rod 162 is then engaged against piston 122 as shown in Figures 4A and 4B and pressure exerted as indicated by the arrow. In so doing, fluid 126 is transferred from cartridge 112 to container 114 as illustrated in Figures 4A and 4B. As a final step, cap 158 is removed and access may be then had to container 114.

Reference will now be had to the embodiment illustrated in Figures 6 to 10. Similar reference numerals in the 200's are employed for components which are similar to those previously described.

The transfer device of this embodiment is generally designated by reference 210. Transfer device 210 includes a conventional fluid containing cartridge 212, a container 214 to which the fluid is to be transferred to, and a shuttle 216.

Cartridge 212 includes a cylindrical body 220 and has a piston 222 located at one end thereof. At the other end, there is provided a pierceable septum 224. The fluid 226 therein is contained in the cavity defined by piston 222 and septum 224.

Container 214 has an outer wall 228 which defines a generally cylindrical container

and which container includes a pierceable plunger 230 at one end thereof. A septum 232 is located at the other end.

Shuttle 216 has a main body portion 236 with legs 238 extending from one end thereof. Legs 238 each have a flange 240 extending diagonally outwardly.

Shuttle 216 has a main body portion 236 through which a cannula extends. The cannula has a first piercing tip 244 located at one end thereof and a second piercing tip 246 located at the other end.

Transfer device 210 includes an outer housing 250. On the interior wall of housing 250, there is provided a first enlarged portion 266 and a second enlarged portion 268. There is also provided a somewhat smaller inwardly extending protrusion 278 as may be seen in Figure 6.

A piston rod 262 has a leg 272 associated therewith. Leg 272 includes an inwardly extending flange 274 for reasons which will become apparent hereinbelow. Leg 272 also includes an outwardly extending protrusion 276.

In operation, and as shown in the drawings, cartridge 212 is placed within transfer device 210 and advanced such that the shoulders of cartridge 212 engage flanges 240 of legs 238. Subsequently, as shown in Figure 7A, piston rod 262 is advanced such that flange 274 of leg 272 will engage the bottom end of cylindrical body 220. As may be seen in Figure 7B, continued advancement of cylindrical body 220 will cause piercing tip 244 to pierce plunger 230. Moveable elements 254 retain the shoulder of container 114 to prevent advancement thereof. As shown in Figure 7B, the air from container 214 is removed when plunger 230 is advanced to a point proximate septum 232. Again, continued advancement of cartridge 212 is permitted, as shown in Figure 7C, by outward movement of leg 238 as

the assembly passes enlarged portions 266 and 268.

Subsequently, as shown in Figure 8, cap 258 is indexed and moveable elements 254 extend are biased outwardly.

Continued pressure on plunger 262 will permit protrusions 276 and 278 to engage each other which results in the outer flexing of leg 272 and in particular flange 274. This permits piston rod 262 to act directly on piston 222 to cause the liquid 226 to pass from cartridge 212 to container 214. Subsequently, cover 258 is removed and access is had to container 214.

Reference will now be had to the embodiment of Figures 11 to 14 and wherein references numerals in the 300's are employed for similar components.

As this embodiment is very similar to that of Figures 6 to 10, only the differences will be described. In this embodiment, cover 358 has a piercing member 388 on the interior thereof. As cover 358 is placed in position, piercing member 388 will pierce the septum 332 of container 314.

A hydrophobic filter 390 covers the venting passage formed within piercing member 388 and will only permit air to escape and not any liquid. This permits the filling of container 314 to the maximum extent as all air is expelled therefrom when the liquid is transferred into the container.

As may be seen in Figures 12 to 14, the same process is followed as was described with respect to Figures 6 to 10.

Reference will now be had to the embodiment of Figure 15 wherein a first arrangement for maintaining sterility in the system is taught. In this embodiment, there is provided a transfer device generally by reference numeral 410 and wherein a fluid is to be

transferred from a cartridge 412 to a container 414. A shuttle 416 provides fluid communication between cartridge 412 and container 414.

Cartridge 412, which contains the fluid to be transferred, has a generally cylindrical body 420 with a piston 422 located at the proximal end thereof. At its distal end, a pierceable septum 424 is provided; septum 424 and plunger 422 sealing fluid 426 therebetween.

Container 414 has an outer wall 428 with a pierceable plunger 430 being located therein adjacent the distal end of container 414. A pierceable septum 432 is located at the distal end of container 414.

Extending about the distal end of container 414 is a cap 434. As may be seen, a piercing member 435 extends through septum 432; piercing member 435 has a fluid passageway or vent 436 extending therethrough. A hydrophobic membrane 438 seats on the end of piercing member 435 to thereby cover fluid passageway 436.

Shuttle 416 includes a cannula 440 having a first piercing tip 442 and a second piercing tip 444. A sheath 425 extends about first piercing tip 442.

The transfer device includes a first outer housing 448 having an outer wall designed by reference numeral 450 and a portion of an inner wall 452. A portion of outer wall 450 and inner wall 452 extend in a parallel but spaced relationship and are joined by wall segment 451. At the distal end of inner wall 452, there is provided a small flange 454.

Outer wall 450 includes a distal wall segment 456 and an intermediate wall segment joined by a jog 458. Similarly, a jog 461 is formed at the point of joinder of intermediate wall segment 460 and a proximal end wall segment 462.

A lower housing 464 extends about cartridge 412 and has, at its distal end, a

recess 466 for reasons which will become apparent hereinbelow.

A coil spring 443 extends between wall segment 451 of outer housing 448 and shuttle 416.

As shown in the drawings, a first O ring 472 extends around an outer portion of the distal end 470 of shuttle 416 to provide a sealing rolling engagement between shuttle distal end 470 and inner wall 452 of outer housing 448. A second O ring 474 provides a sealing rolling engagement between a distal end of intermediate portion 460 of outer housing and the container 414.

As will be noted, lower housing 464 has a recess 466 which engages a protrusion 467. A pusher mechanism generally designated by reference 480 includes a plunger rod 482 and an outer housing 484. Outer housing 484 has first and second protrusions 486 and 488 thereon. An outer housing 490 surrounds pusher assembly 480.

In operation, and as is shown in Figures 15B to 15G, pushing mechanism 480 is advanced as indicated by arrow 491. Any suitable means for applying the force may be used. In so doing, outer housing 484 and protrusion 486 engage the bottom of cartridge 412 to advance the same. As may be seen in Figure 15C, piercing tip 442 will pass through sheath 425 and septum 424 to thereby enter cartridge 412. It will be noted that, at this point in time, liquid will not necessarily pass through cannula 440 since it is not under any pressure.

A further advancement, as shown in Figure 15D, will compress spring 443 and needle or piercing tip 444 of cannula 440 will then pierce plunger 430. At this point in time, and as shown in Figure 15D, plunger 482 will engage with piston 422. This is permitted when protrusion 488 passes the end of housing 490 and is thus allowed to extend outwardly and

thereby release plunger rod 482. Thus, the liquid will commence passing through cannula 440 to enter the interior of container 414.

After substantially all of the liquid has been transferred, cap 434 is removed and container 414 may then be removed from the upper housing 448.

Figures 16 to 20 illustrate various means of maintaining sterility during the transfer operation. In the embodiment of Figure 16, O ring 572 extends around the distal end of shuttle 516. It will be noted that there is a cylinder 591 located between the outer wall 528 of container 514.

In the embodiment of Figure 17, a plurality of O rings 672 are placed about the distal end of shuttle 616.

Figure 18 illustrates an embodiment wherein a collapsible sheath 775 is placed about piercing tip 444 of cannula 440. The sheath is attached to the side wall segment 757 of housing 748.

A similar arrangement is illustrated in Figure 19 with the use of a sheath 875 which is a different place on side wall 857.

Figure 20 illustrates a different embodiment or attachment of sheath 975 which extends about piercing tip 944 of cannula 940. In both the embodiments of Figures 19 and 20, it will be noted that plungers 830 and 930 respectively are located at the rear end of container 814 and 914 when initially inserted into place.

The functioning of the pusher mechanisms in Figures 16 to 20 is substantially equivalent to that previously described and hence will not be discussed in any greater detail.

WE CLAIM:

1. A system for transferring a fluid, said system comprising:
 - a housing (150);
 - a first container (112) having a fluid therein (126), said first container (112) having an open top, said open top being sealed by a septum (124), a piston (122) located within said first container, said piston (122) and said septum (124) defining a compartment having said fluid;
 - a second container (114), said second container (114) having a body, a cavity within said body, an open top and an open bottom, said open top being sealed by a pierceable septum (132), a plunger (130) within said cavity, said plunger being located proximate said septum so as to minimize any air between said pierceable septum (132) and said plunger (130);
 - said first container (112) and said second container (114) being located within said housing at opposite ends thereof;
 - a moveable needle shuttle (116), said needle shuttle having first (144) and second (146) piercing ends and having a fluid passageway extending between said piercing ends;
 - the arrangement being such that a second one of said piercing ends (146) is adapted to pierce said plunger (130) of said second container, and a first one of said piercing ends (144) being designed to pierce said septum (124) of said first container when one of said containers is moved towards the other of said containers to contact said piercing ends.
2. The system of Claim 1 wherein said first container comprises a syringe body (112).
3. The system of Claim 1 wherein said system includes means (154) for retaining said second container at one end of said housing.

4. The system of Claim 3 wherein said means for retaining said second container comprises at least first and second outwardly biased elements (154) extending inwardly from a housing wall, and a cap member (158) engaged with said housing wall, said cap member retaining said elements (154) in an inwardly extending position.
5. The system of Claim 1 further including a vent (436) extending between the interior of said second container and exteriorly thereof, said vent including a hydrophobic membrane (438) sealing said vent.
6. The system of Claim 1 further including a pusher mechanism (262, 272) within said housing (150) located rearwardly of said first container (212), said pusher mechanism having a first pushing element (272) and a second pushing element (262), said first pushing element (272) being designed to push the body of said first container (112), said second pushing element (262) being designed to push said piston (222), the arrangement being such that upon an initial pushing movement, said first pushing element (272) contacts said body to advance said first container (212), and a deflector (274) to cause said first pusher element to deflect out of contact with said first container body and permit said second pusher element (262) to exert pressure on said piston (222).
7. The system of Claim 1 further including a sheath (425) extending about said first one of said piercing ends.
8. The system of Claim 1 further including spring means (443).
9. A method for transferring a fluid from a first container (412) to a second container (414), said first container having an open top sealed by a septum (424), a piston (422) located within said first container (412), said piston (422) and said septum (424) defining a compartment having said fluid (426) therein, said second container (414) having a body, a

cavity within said body, an open top and an open bottom, said open top being sealed by a pierceable septum (432), a plunger (430) within said cavity, said plunger (430) being located proximate said septum (432) so as to minimize any air between said septum and said plunger, comprising the steps of:

supplying a housing (448) having a moveable shuttle (416) therein, said shuttle having first and second piercing members (442, 444) located at either end thereof with a fluid passageway extending between said first and second piercing ends;

placing said second container (414) within said housing;

placing said first container (412) having said fluid (426) therein within said housing;

advancing one of said containers (412, 414) to cause said piercing members to pierce said plunger (430) of said second container and said pierceable septum (424) of said first container;

exerting pressure on a first container piston (422) to cause said fluid (426) to pass from said first container through said fluid passageway (440) into said second container and cause said plunger (430) to move rearwardly towards said open bottom.

10. The method of Claim 9 wherein the step of advancing one of said containers comprises the step of advancing said first container (112) to cause said second piercing end (144) to sequentially pierce said plunger (130) of said second container and subsequently said first piercing end (146) to pierce said pierceable septum (124) of said first container.

11. The method of Claim 9 wherein the step of advancing one of said containers comprises the step of advancing said first container (412) to cause said first piercing end (442) to pierce said pierceable septum (424) of said first container, and subsequently cause said second piercing end (444) to pierce said plunger (430) of said second container.

12. A system for transferring a fluid, said system comprising:

a housing (448);

a first container (412) having a fluid (426) therein, said first container (412) having an open top, a septum (424) sealing said open top;

a second container (414), said second container (414) having a body, a cavity within said body, an open top and an open bottom, said open top being sealed by a pierceable septum (432), and a plunger within said cavity for sealing said open bottom;

a vent (436) from within said second container to the exterior thereof, a hydrophobic membrane (438) sealing said vent;

said first and second containers (412, 414) being mounted at opposite ends of said housing, a moveable needle shuttle (416) mounted in said housing intermediate said first and second containers (412, 414), said needle shuttle having first and second piercing ends (442, 444), a fluid passageway extending between said first and second piercing ends.

13. A method for transferring fluid from a first container to a second container, said method comprising the steps of supplying a first container (412) having a fluid (426) therein, said first container (412) having an open end sealed by a pierceable septum (424), a piston (422) at another end, a second container (414) for receiving the fluid to be transferred thereto, said second container having a body, a cavity within said body, an open top and an open bottom, said open top being sealed by a pierceable septum (432), a plunger (430) sealing said open bottom, a vent (436) extending from said cavity to the exterior of said container (414), a hydrophobic membrane (438) mounted in said vent, a needle shuttle having first and second piercing ends (442, 444) with a fluid passageway extending between said first and second piercing ends;

- 19 -

placing said first container (412) within said housing at one end thereof;
placing said second container in said housing (448) at a second end thereof;
advancing said first container (412) so as to cause said needle shuttle to advance towards said second container (414) and thereby cause said first piercing end (442) to pierce said plunger (430) of said second container and cause said second piercing end (444) to pierce said septum (424) of said first container; and
exerting a pressure on said piston (422) to cause said fluid to be advanced to said second container and to expel substantially all the air therefrom through said vent and said hydrophobic membrane (436).

14. A system for transferring a fluid, said system comprising:

a housing (448);

a first container (412) having a fluid therein (426), said first container having an open top and an open bottom, said open top being sealed by a septum (424) and said open bottom being sealed by a piston (422);

a second container (414), said second container having a body, a cavity within said body, an open top and an open bottom, said open top being sealed by a pierceable septum (432), a plunger (430) within said cavity sealing said open bottom;

said first container (412) and said second container (414) being located within said housing (448) at opposite ends thereof;

a moveable needle shuttle, said needle shuttle having first and second piercing ends (442, 444) and having a fluid passageway extending between said piercing ends;

a pusher mechanism located rearwardly of said first container, said pusher mechanism having a first pushing element (484) and a second pushing element (482), said

first pushing element (484) being designed to push the body of said first container (412), said second pushing element (482) being designed to push said piston (422), the arrangement being such that upon an initial pushing movement, said first pushing element contacts said body to advance said first container and means to then permit said second pusher element to exert pressure on said piston.

15. A system for transferring a fluid from a first container (412) to a second container (414, said system comprising:

an upper housing (448), said upper housing having an open top and an open bottom, said open top being designed to receive said second container (414), said second container (414) having a body, a cavity within said body, an open top and an open bottom, said open top of said second container being sealed by a pierceable septum (432), a plunger (430) within said cavity, said plunger (430) being located proximate said septum (432) so as to minimize any air between said septum and said plunger, a vent (434) extending between said cavity and exterior of said body, a hydrophobic membrane (438) sealing said vent;

a lower housing (468), said lower housing having an open top and an open bottom, said open bottom being designed to receive said first container (412);

a needle hub (416) mounted intermediate said first and second containers, said needle hub having a cannula (440) with first and second piercing ends (442, 444), a fluid passageway extending between said first and second ends;

a sheath (425) extending about said first piercing end (442), said sheath being attached to said needle hub; and

sealing means (472) extending between an outer wall of said needle hub and an adjacent wall (457).

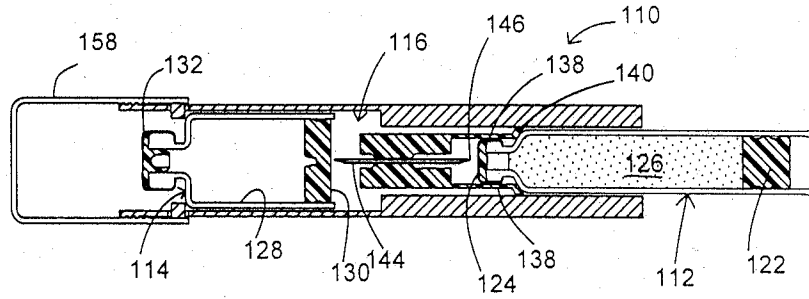

Fig. 1

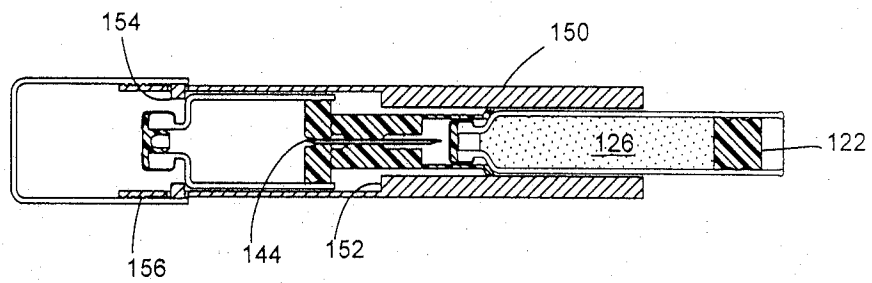

Fig. 2A

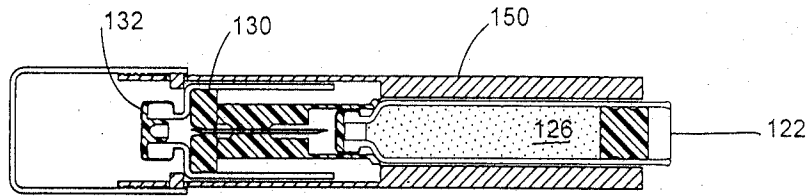

Fig. 2B

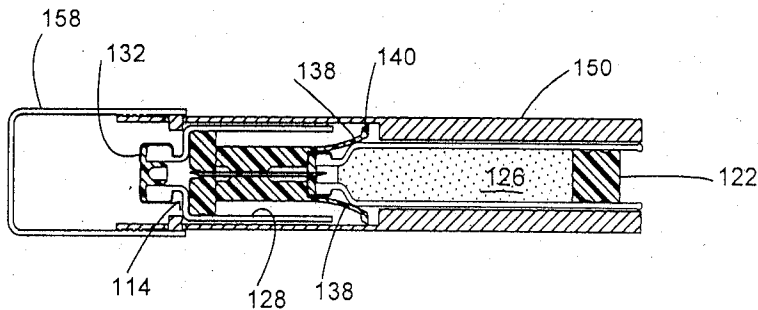

Fig. 2C

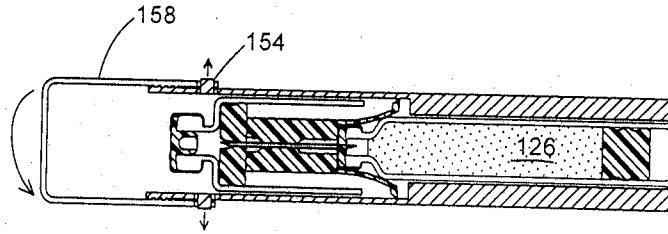

Fig. 3

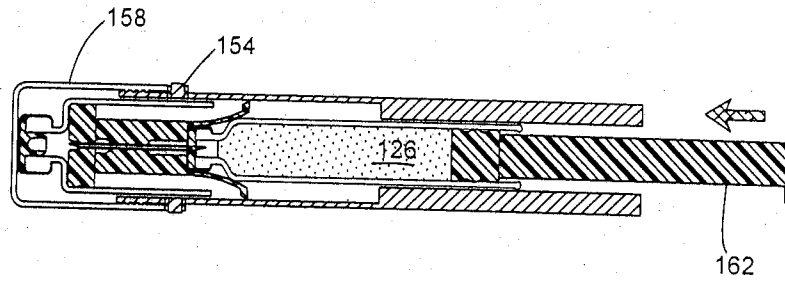

Fig. 4A

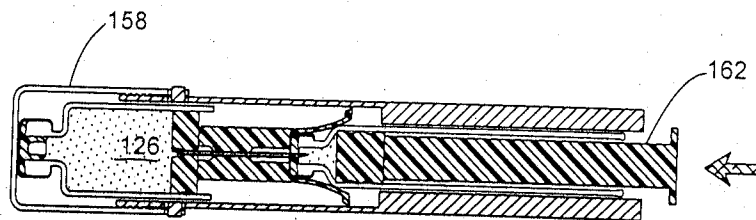

Fig. 4B

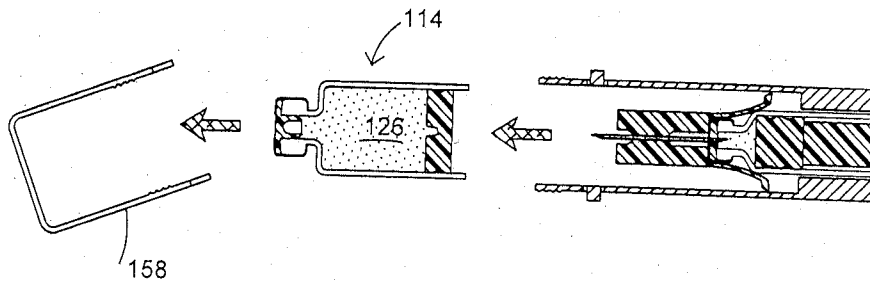

Fig. 5

Fig. 6

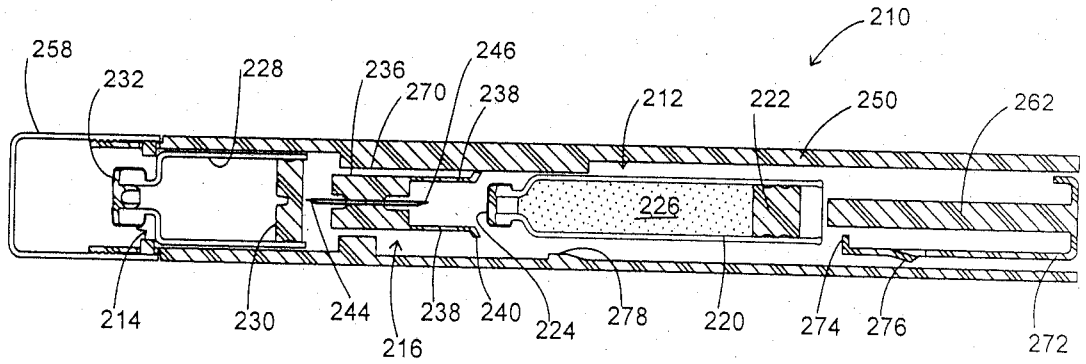

Fig. 7A

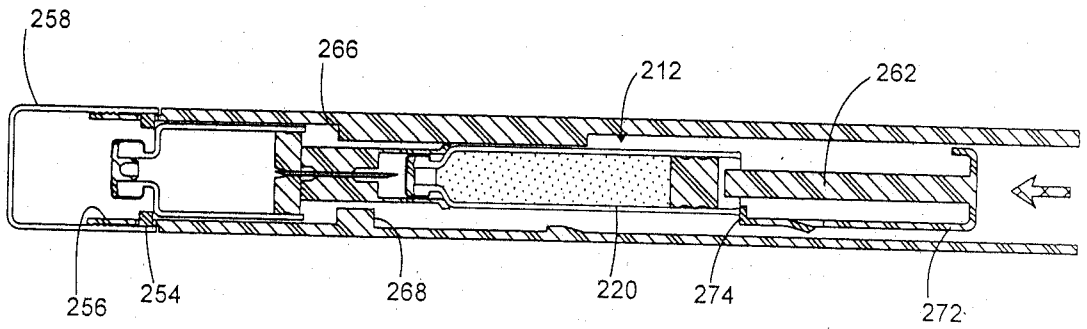

Fig. 7B

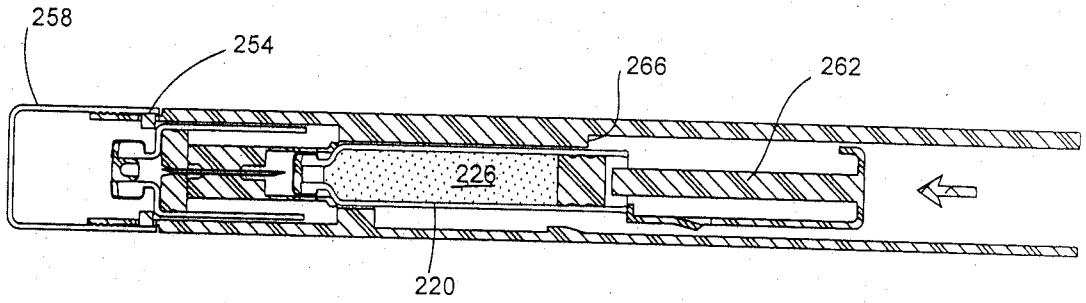
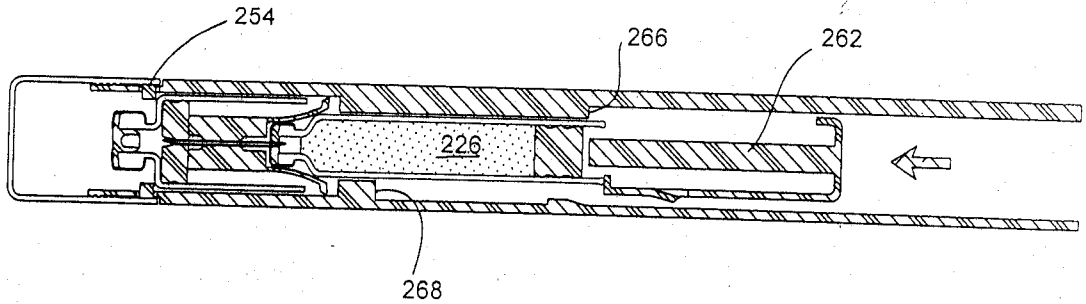

Fig. 7C



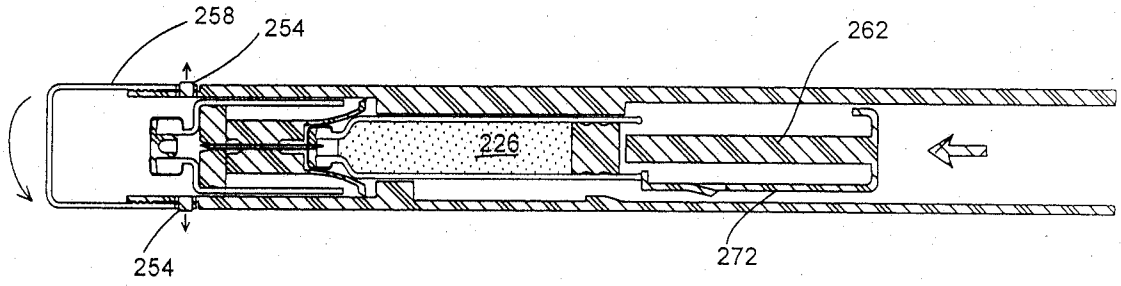

Fig. 8

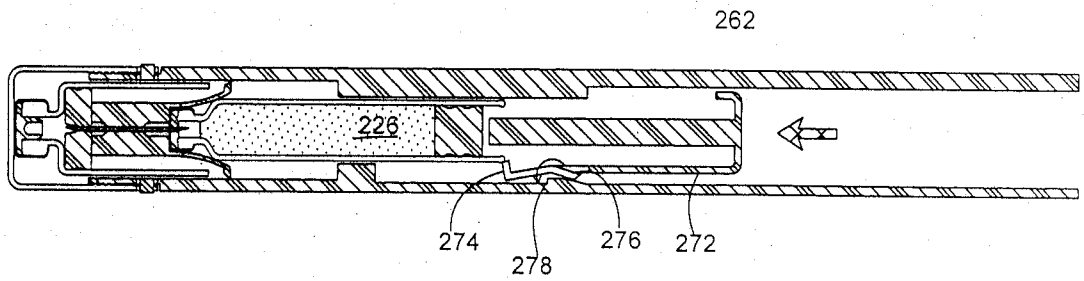

Fig. 9A

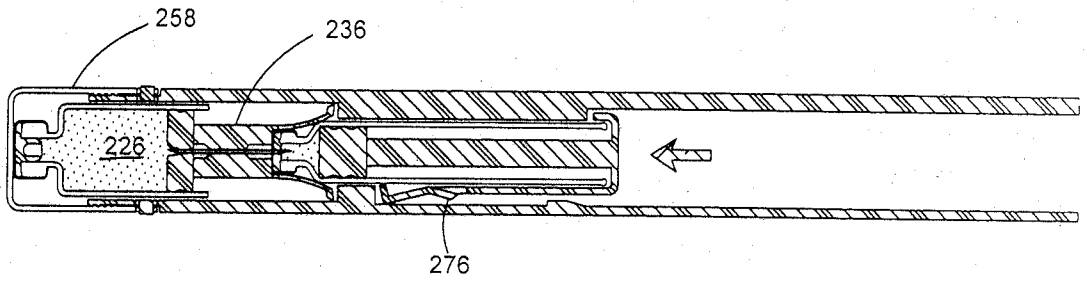

Fig. 9B

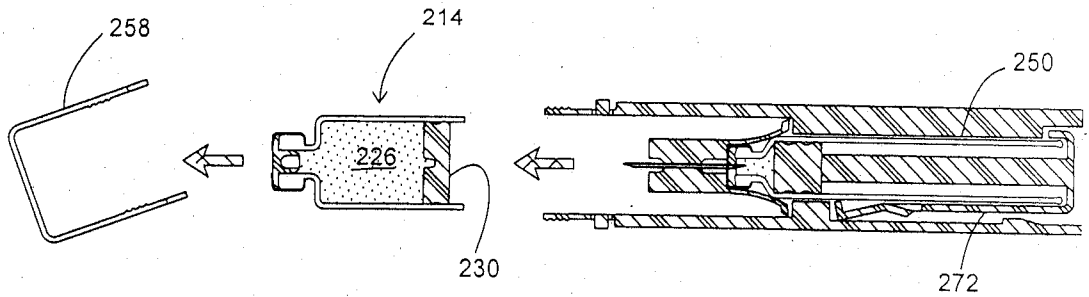

Fig. 10

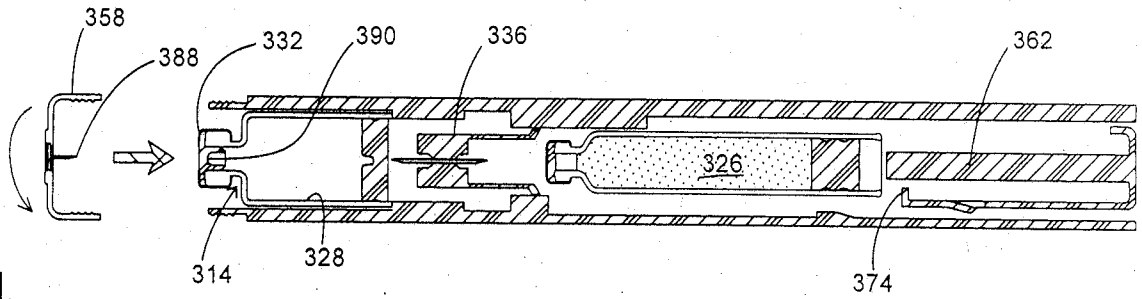

Fig. 11

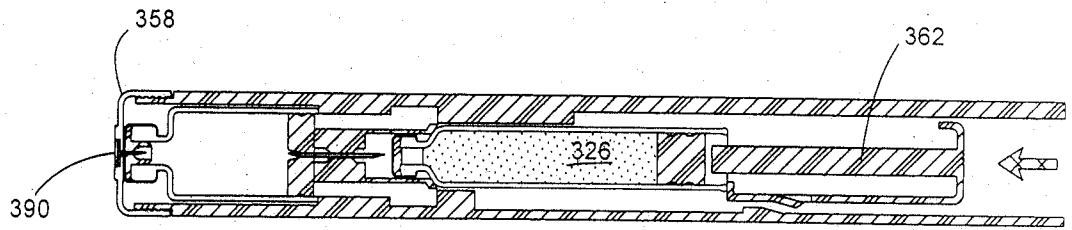

Fig. 12A

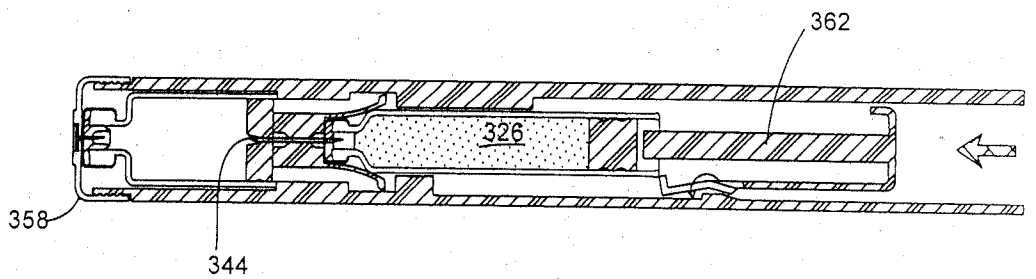

Fig. 12B

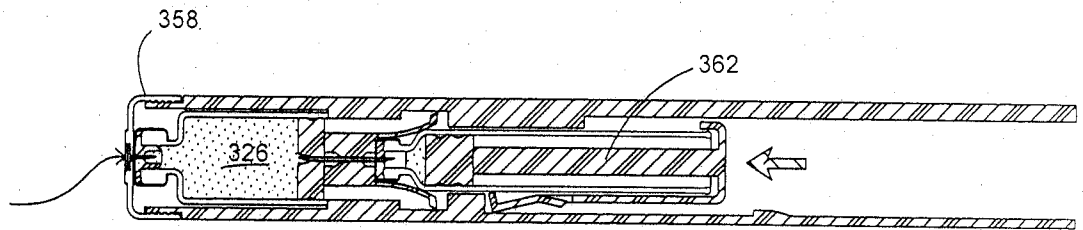

Fig. 13

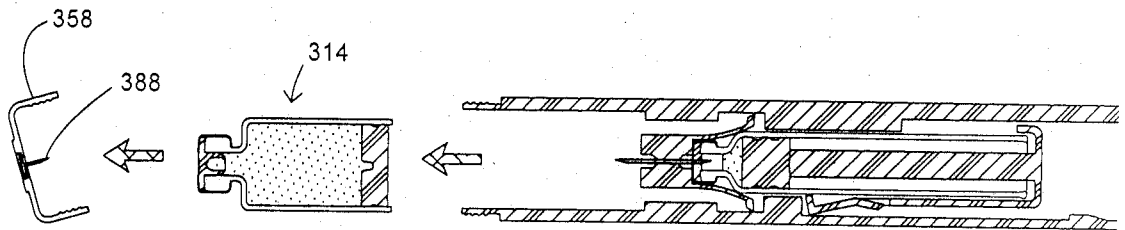

Fig. 14

Fig. 15B

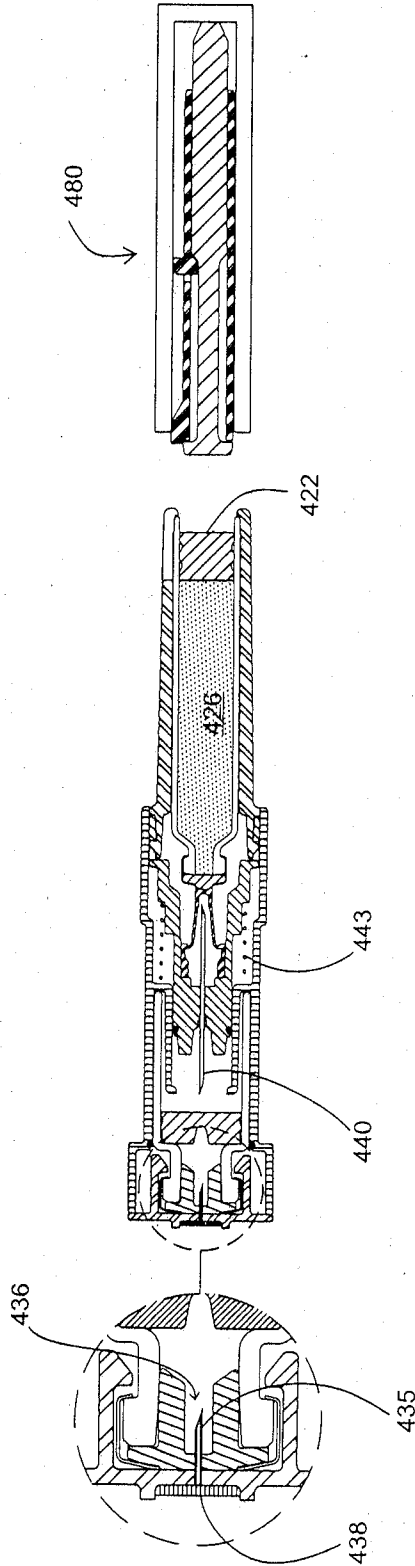

Fig. 15C

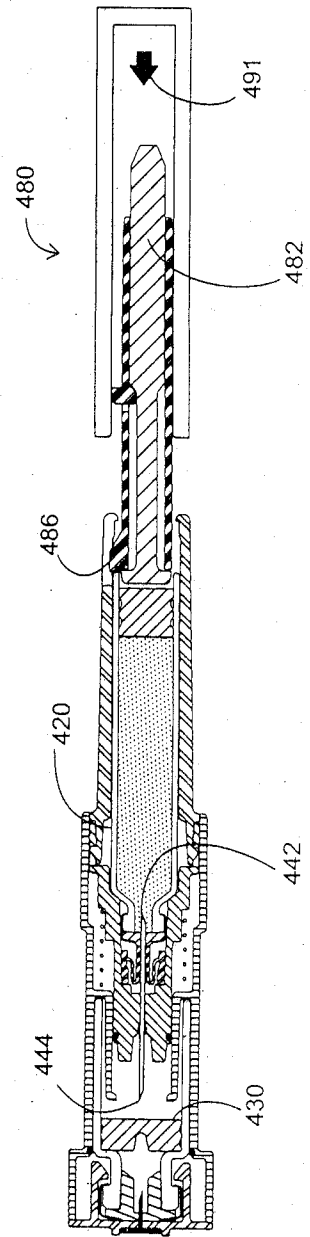

Fig. 15D

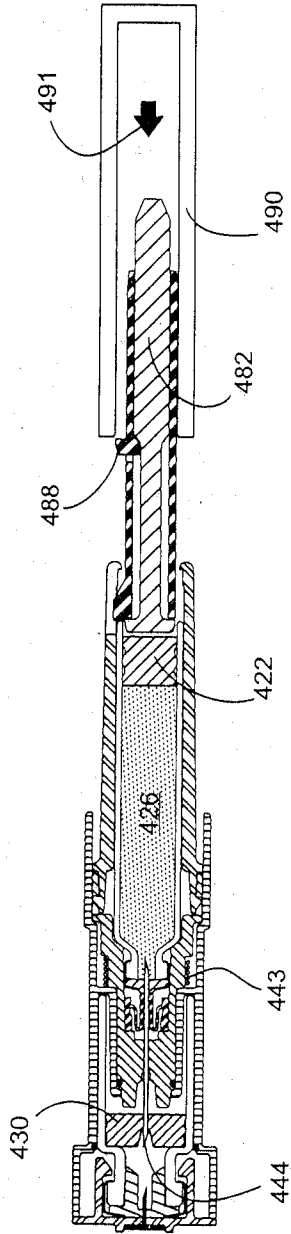

Fig. 15E

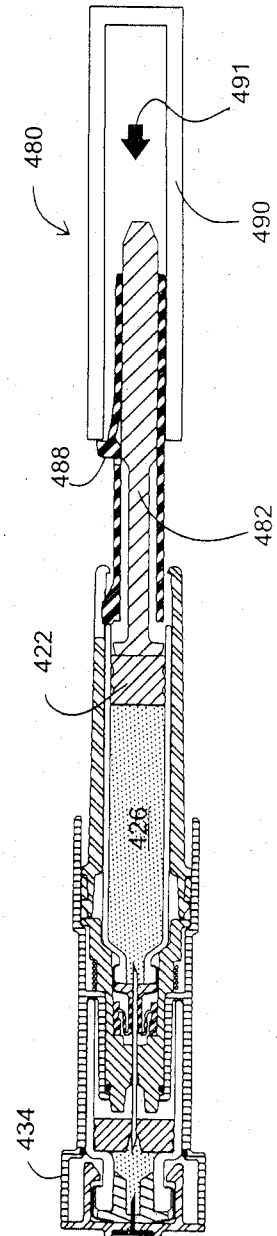

Fig. 15F

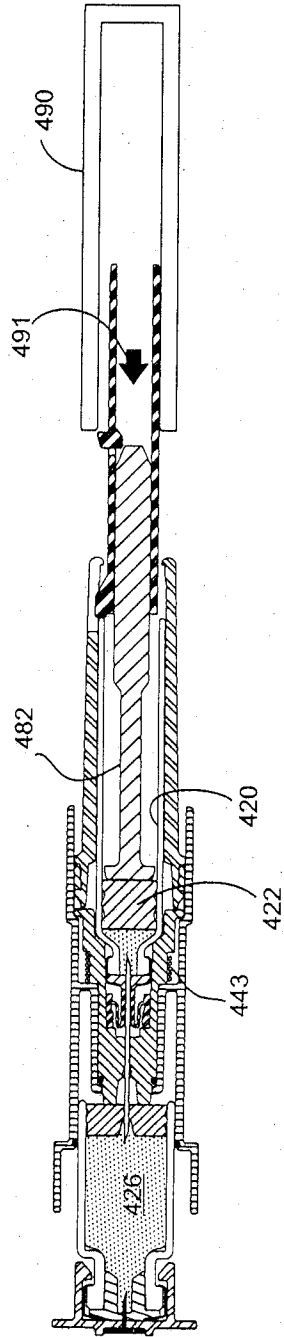

Fig. 15G

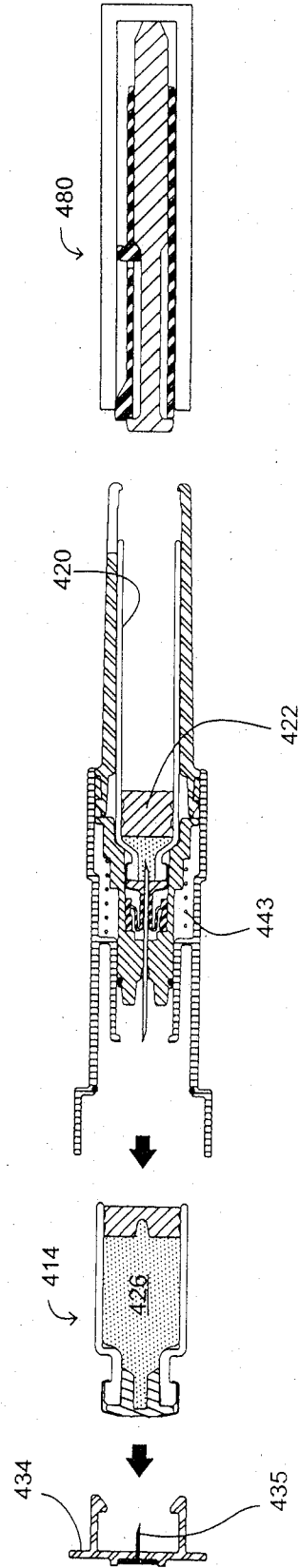

Fig. 16

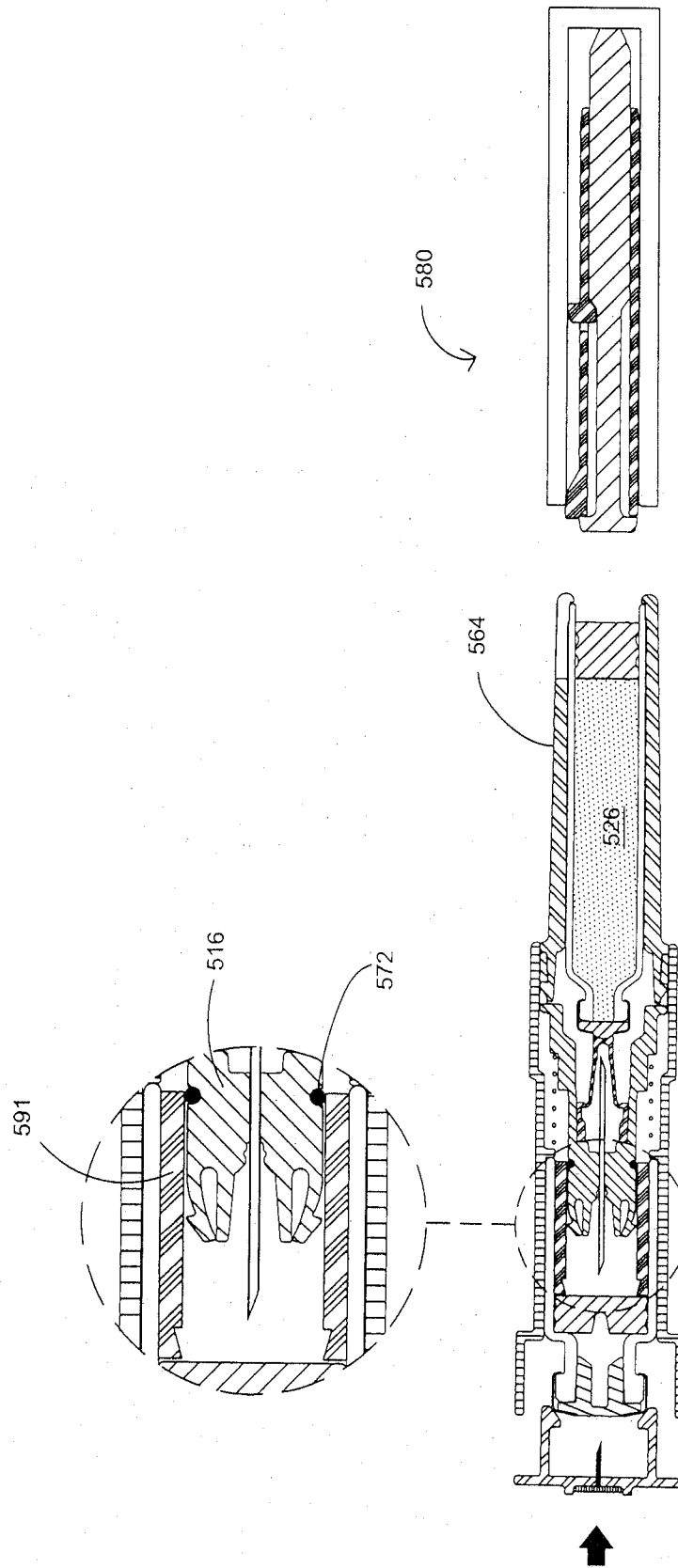

Fig. 17

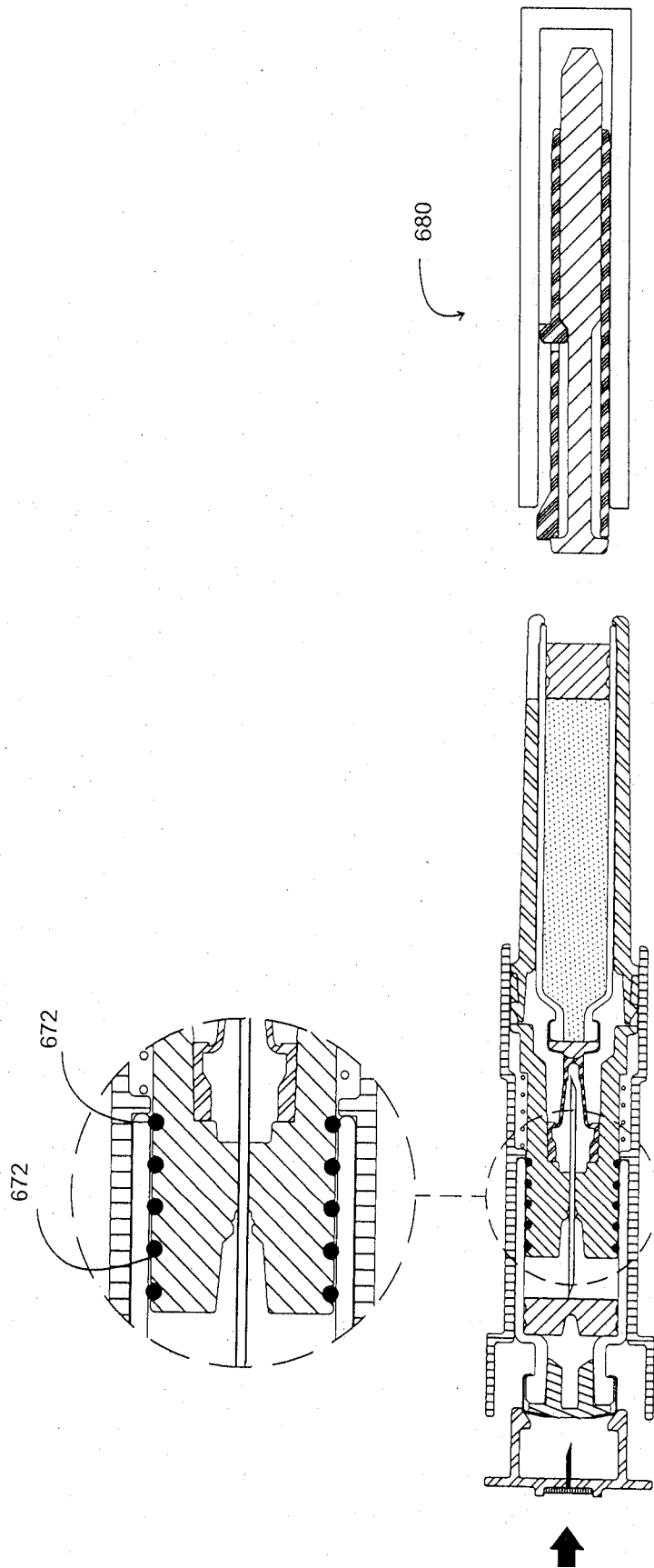

Fig. 18

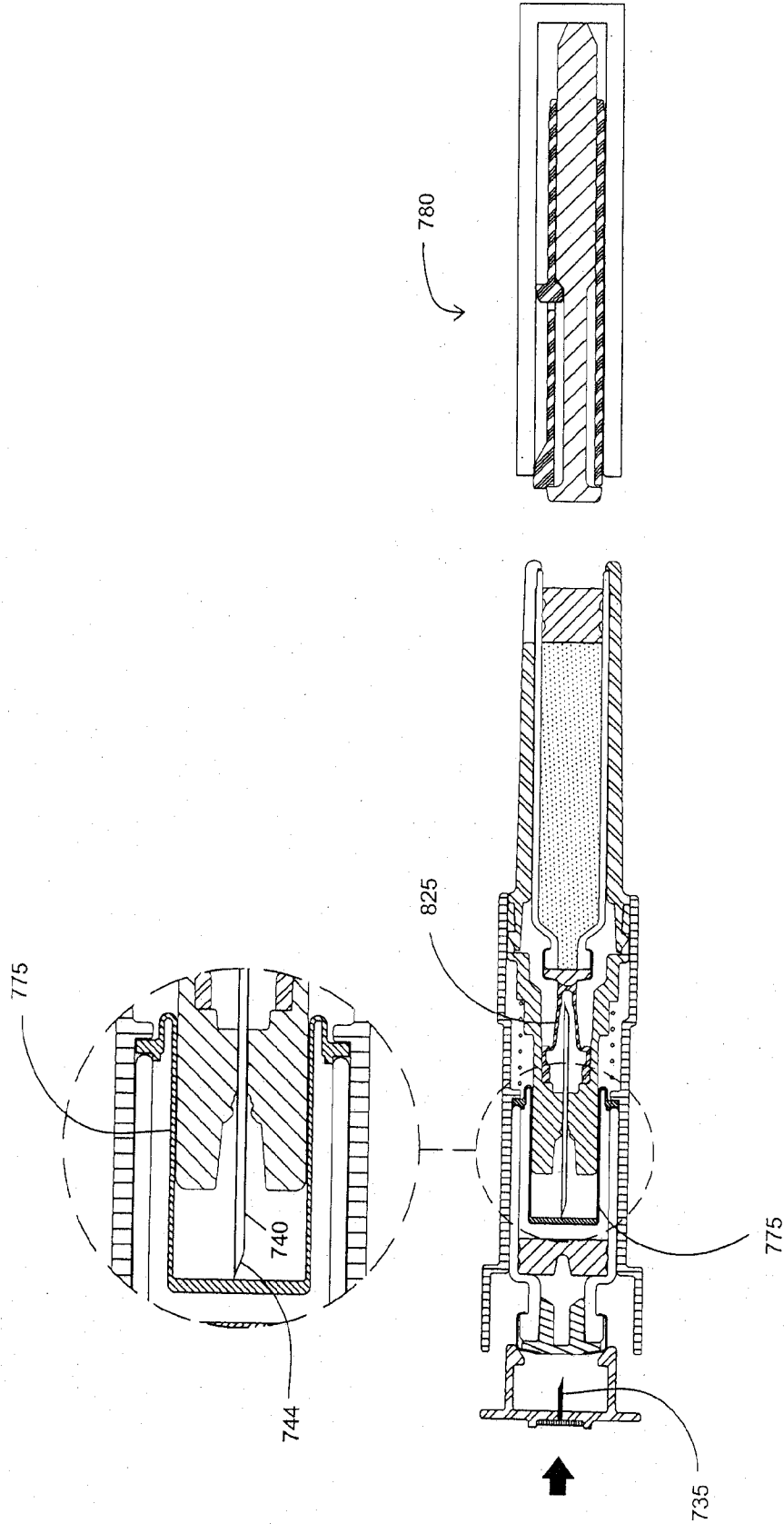

Fig. 19

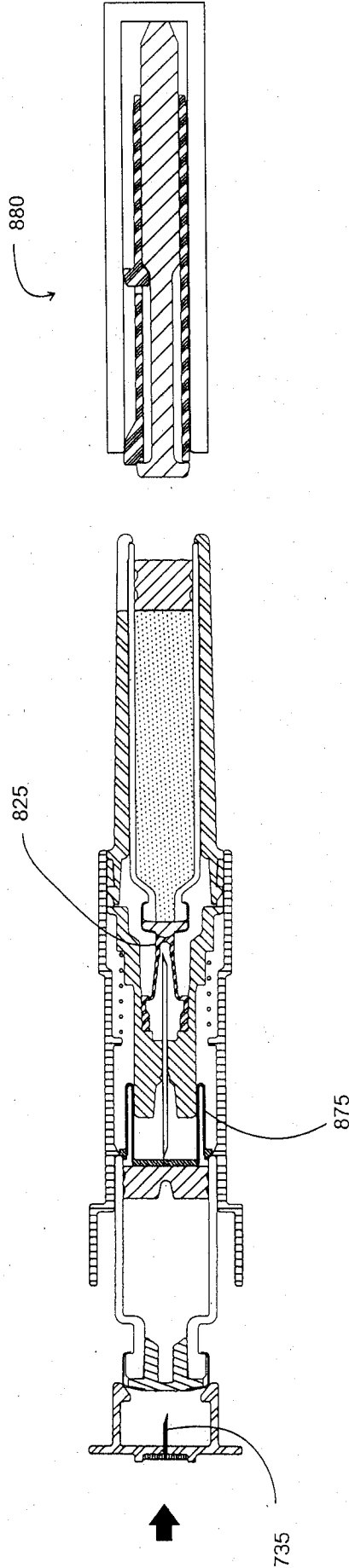
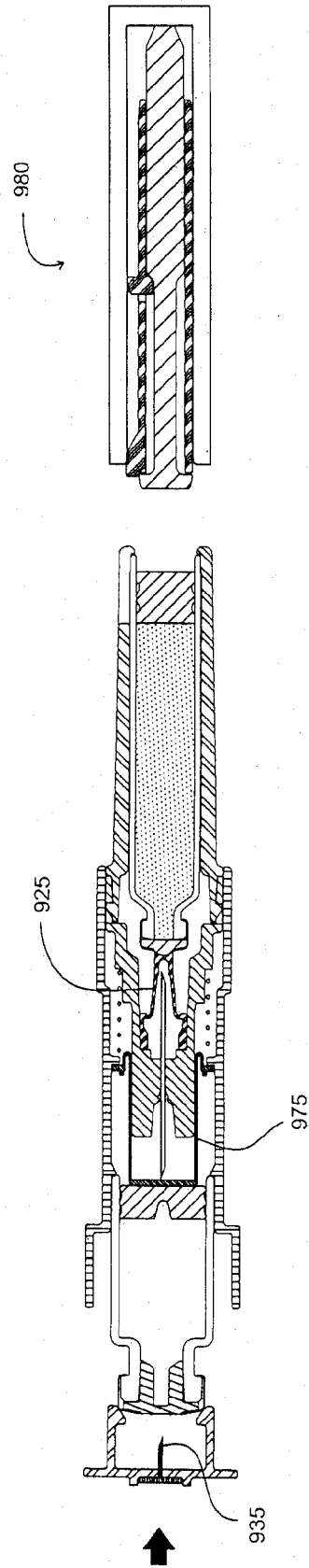

Fig. 20



INTERNATIONAL SEARCH REPORT

International application No.
PCT/CA2008/001125

<p>A. CLASSIFICATION OF SUBJECT MATTER IPC: A61J 1/20 (2006.01) , B65D 83/76 (2006.01) , B67D 5/56 (2006.01) According to International Patent Classification (IPC) or to both national classification and IPC</p>		
<p>B. FIELDS SEARCHED</p>		
<p>Minimum documentation searched (classification system followed by classification symbols) IPC: A61J-1* ; A61J-1/20; A61M-5/315; B65D-83/76; B67D-5/56 US Class: 604/411-413</p>		
<p>Documentation searched other than minimum documentation to the extent that such documents are included in the fields searched</p>		
<p>Electronic database(s) consulted during the international search (name of database(s) and, where practicable, search terms used) Delphion; Canadian Patent Database; esp@cenet; West keywords: piston, plunger, rod, vial</p>		
<p>C. DOCUMENTS CONSIDERED TO BE RELEVANT</p>		
Category*	Citation of document, with indication, where appropriate, of the relevant passages	Relevant to claim No.
<u>X</u> Y	US 6902543 B1 (CHERIF-CHEIKH ET AL.) 7 June 2005 (07-06-2005) refer figures 1, 7A & description	<u>1-4, 7, 9-11</u> 5, 8, 12, 13, 15
Y	WO 2004/000412 A1 (FREMMING ET AL.) 31 December 2003 (31-12-2003) refer to figure 3; desc. pg. 4, lin. 9-22	5, 12, 13, 15
Y	US 4226236 (GENESE) 7 October 1980 (07-10-1980) refer to figures 1-3; col. 4, lin. 27	5, 12, 13, 15
<u>Y</u> A	CA 2514673 A1 (REYNOLDS ET AL.) 5 February 2007 (05-02-2007) refer to figure 1	<u>8</u> 12, 13, 15
A	US 6746438 B1 (ARNISSOLLE) 8 June 2004 (08-06-2004) refer to figures	1, 9, 12, 13, 15
A	US 6974446 B2 (HOMMANN ET AL.) 13 December 2005 (13-12-2005) refer to figures	1, 9, 12, 13, 15
<p><input checked="" type="checkbox"/> Further documents are listed in the continuation of Box C.</p>		<p><input checked="" type="checkbox"/> See patent family annex.</p>
*	Special categories of cited documents :	“T”
“A”	document defining the general state of the art which is not considered to be of particular relevance	later document published after the international filing date or priority date and not in conflict with the application but cited to understand the principle or theory underlying the invention
“E”	earlier application or patent but published on or after the international filing date	“X”
“L”	document which may throw doubts on priority claim(s) or which is cited to establish the publication date of another citation or other special reason (as specified)	document of particular relevance; the claimed invention cannot be considered novel or cannot be considered to involve an inventive step when the document is taken alone
“O”	document referring to an oral disclosure, use, exhibition or other means	“Y”
“P”	document published prior to the international filing date but later than the priority date claimed	document of particular relevance; the claimed invention cannot be considered to involve an inventive step when the document is combined with one or more other such documents, such combination being obvious to a person skilled in the art
		“&”
		document member of the same patent family
<p>Date of the actual completion of the international search 22 September 2008 (22-09-2008)</p>		<p>Date of mailing of the international search report 25 September 2008 (25-09-2008)</p>
<p>Name and mailing address of the ISA/CA Canadian Intellectual Property Office Place du Portage I, C114 - 1st Floor, Box PCT 50 Victoria Street Gatineau, Quebec K1A 0C9 Facsimile No.: 001-819-953-2476</p>		<p>Authorized officer Ishtiaque Ibne Rashid 819- 953-0787</p>

INTERNATIONAL SEARCH REPORTInternational application No.
PCT/CA2008/001125**Box No. II Observations where certain claims were found unsearchable (Continuation of item 2 of the first sheet)**

This international search report has not been established in respect of certain claims under Article 17(2)(a) for the following reasons :

1. Claim Nos. :
because they relate to subject matter not required to be searched by this Authority, namely :

2. Claim Nos. :
because they relate to parts of the international application that do not comply with the prescribed requirements to such an extent that no meaningful international search can be carried out, specifically :

3. Claim Nos. :
because they are dependent claims and are not drafted in accordance with the second and third sentences of Rule 6.4(a).

Box No. III Observations where unity of invention is lacking (Continuation of item 3 of first sheet)

This International Searching Authority found multiple inventions in this international application, as follows :

See supplemental sheet

1. As all required additional search fees were timely paid by the applicant, this international search report covers all searchable claims.
2. As all searchable claims could be searched without effort justifying additional fees, this Authority did not invite payment of additional fees.
3. As only some of the required additional search fees were timely paid by the applicant, this international search report covers only those claims for which fees were paid, specifically claim Nos. :
4. No required additional search fees were timely paid by the applicant. Consequently, this international search report is restricted to the invention first mentioned in the claims; it is covered by claim Nos. :

- Remark on Protest** The additional search fees were accompanied by the applicant's protest and, where applicable, the payment of a protest fee.
- The additional search fees were accompanied by the applicant's protest but the applicable protest fee was not paid within the time limit specified in the invitation.
- No protest accompanied the payment of additional search fees.

INTERNATIONAL SEARCH REPORTInternational application No.
PCT/CA2008/001125

C (Continuation). DOCUMENTS CONSIDERED TO BE RELEVANT

Category*	Citation of document, with indication, where appropriate, of the relevant passages	Relevant to claim No.
A	WO 02/072173 A2 (BARKER ET AL.) 19 September 2002 (19-09-2002) refer to figures	1, 9, 12, 13, 15
A	WO 01/60311 A1 (POLZIN) 23 August 2001 (23-08-2001) refer to figures 25-34	6, 14
A	CA 2444538 C (ACHA GANDARIAS) 18 July 2002 (18-07-2002) refer to figures	6, 14

INTERNATIONAL SEARCH REPORT
Information on patent family members

International application No.
PCT/CA2008/001125

Patent Document Cited in Search Report	Publication Date	Patent Family Member(s)	Publication Date
US 6902543B1	07-06-2005	AT 327789T	15-06-2006
		AU 7796400A	23-04-2001
		CA 2386160A1	19-04-2001
		CN 1216657C	31-08-2005
		CN 1378466A	06-11-2002
		CZ 20021291A3	16-04-2003
		DE 60028401D1	06-07-2006
		DE 60028401T2	24-05-2007
		EP 1223999A1	24-07-2002
		EP 1223999B1	31-05-2006
		ES 2261244T3	16-11-2006
		FR 2799654A1	20-04-2001
		FR 2799654B1	11-01-2002
		HK 1050495A1	02-12-2005
		HU 0203515A2	28-03-2003
		IL 148897D0	12-09-2002
		JP 2003511159T	25-03-2003
		NZ 518286A	25-06-2004
		PL 355150A1	05-04-2004
		RU 2258537C2	20-08-2005
US 2005075602A1	07-04-2005		
WO 0126718A1	19-04-2001		
WO 2004000412A1	31-12-2003	EP 1549385A1	06-07-2005
		JP 2005532096T	27-10-2005
		US 2003236497A1	25-12-2003
US 4226236A	07-10-1980	CA 1134699A1	02-11-1982
CA 2514673A1	05-02-2007	US 2007078428A1	05-04-2007
US 6746438B1	08-06-2004	AT 275374T	15-09-2004
		AU 3300300A	04-10-2000
		DE 60013565D1	14-10-2004
		DE 60013565T2	06-10-2005
		EP 1161217A1	12-12-2001
		EP 1161217B1	08-09-2004
		ES 2228475T3	16-04-2005
		FR 2790948A1	22-09-2000
		FR 2790948B1	22-06-2001
		JP 2002538893T	19-11-2002
		WO 0054723A1	21-09-2000
US 6974446B2	13-12-2005	AU 6573201A	30-01-2002
		DE 10034270A1	14-02-2002
		US 2003139707A1	24-07-2003
		WO 0205878A1	24-01-2002

INTERNATIONAL SEARCH REPORT
Information on patent family members

International application No.
PCT/CA2008/001125

Patent Document Cited in Search Report	Publication Date	Patent Family Member(s)	Publication Date
WO 02072173A2	19-09-2002	BR PI0208064A	10-10-2006
		CA 2440888A1	19-09-2002
		CN 1509192A	30-06-2004
		EP 1372756A2	02-01-2004
		EP 1372756A4	21-05-2008
		JP 2005508656T	07-04-2005
		MX PA03007940A	15-10-2004
		US 2002177819A1	28-11-2002
		WO 02072173A3	16-10-2003
WO 0160311A1	23-08-2001	AT 275914T	15-10-2004
		CA 2390477A1	23-08-2001
		DE 10103287A1	23-08-2001
		DE 50007821D1	21-10-2004
		DK 1263387T3	24-01-2005
		EP 1263387A1	11-12-2002
		EP 1263387B1	15-09-2004
		ES 2223644T3	01-03-2005
		JP 2003525667T	02-09-2003
		US 2002173752A1	21-11-2002
		CA 2444538A1	18-07-2002
AU 2001256373B2	16-12-2004		
BR 0116800A	03-02-2004		
CA 2444538C	22-01-2008		
CN 1291763C	27-12-2006		
CN 1496274A	12-05-2004		
CZ 20032091A3	12-11-2003		
DE 60124773D1	04-01-2007		
DE 60124773T2	11-10-2007		
EP 1360969A1	12-11-2003		
EP 1360969B1	22-11-2006		
ES 2187333A1	01-06-2003		
ES 2187333B1	16-06-2005		
ES 2276787T3	01-07-2007		
IL 156881D0	08-02-2004		
JP 2004516909T	10-06-2004		
MA 26268A1	01-09-2004		
MX PA03006170A	11-12-2003		
PL 365341A1	27-12-2004		
RU 2266756C2	27-12-2005		
RU 2003123502A	20-02-2005		
US 2004073172A1	15-04-2004		
WO 02055141A1	18-07-2002		
ZA 200306067A	06-08-2004		

Box No. III - Observations where unity is lacking (continued)

Claims 1-11 are directed to a system for transferring a fluid, comprising: a housing, a first container with a septum and a piston; a second container with a septum and a plunger; and a moveable needle shuttle.

Claims 12, 13 and 15 are directed to a system for transferring a fluid, comprising: a housing, a first container with a septum; a second container with a septum and a plunger; a moveable needle shuttle; and a vent with a hydrophobic membrane.

Claim 14 is directed to a system for transferring a fluid, comprising: a housing, a first container with a septum and a piston; a second container with a septum and a plunger; a moveable needle shuttle and a pusher mechanism with a first and second pushing element.

In view of the prior art (*a posteriori analysis*), it is concluded that independent claims 12, 13 and 15 do not contain novel/inventive subject matter and thus do not have any technical "special features" (a common inventive link) that link these claims with the known device of independent claim 1. The subject matter of claim 12, 13 and 15 are a combination of known elements that arrive at a known and expected result.