

B. M. WILKERSON.
HEAD REST.

(Application filed Apr. 29, 1899.)

(No Model.)

2 Sheets—Sheet 1.

FIG. 3.

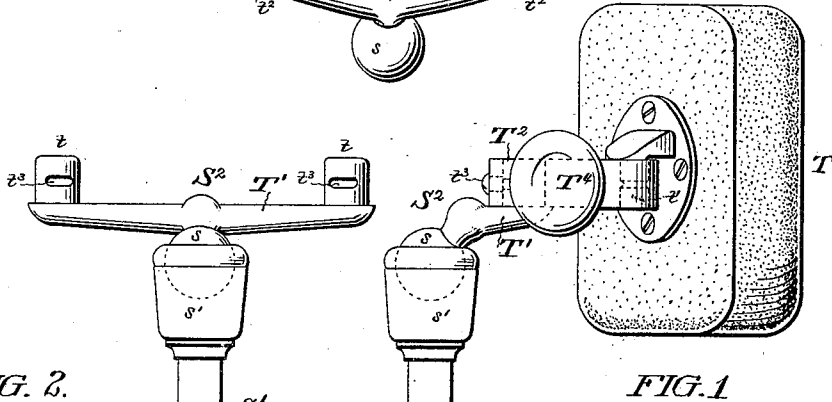
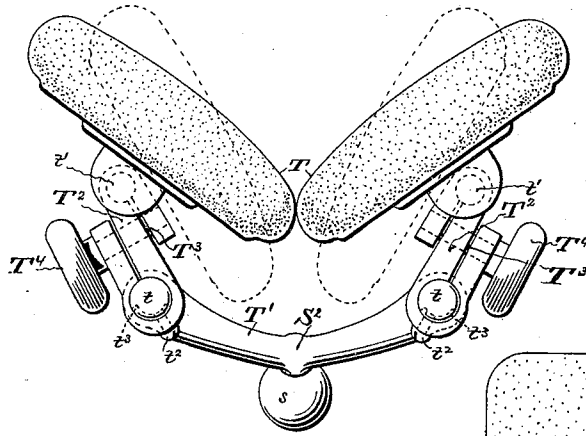

FIG. 2.

FIG. 1

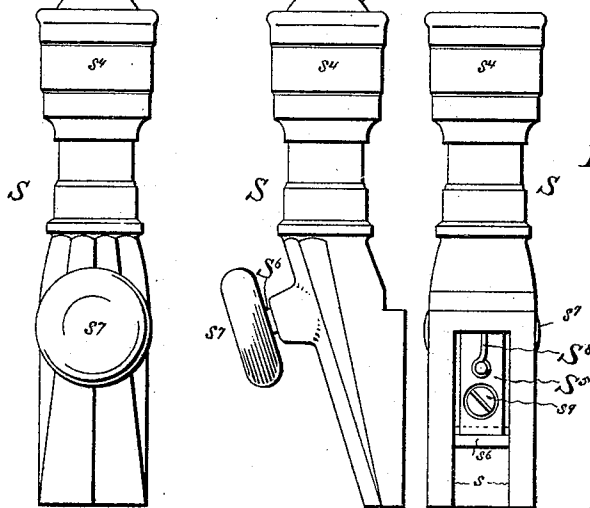

FIG. 4.

WITNESSES:

B. M. Wilkerson
J. B. Vaile

INVENTOR:

Basil M. Wilkerson,
by Edw. F. Simpson, Jr.,
Attorney.

No. 642,404.

Patented Jan. 30, 1900.

B. M. WILKERSON.
HEAD REST.

(Application filed Apr. 29, 1899.)

(No Model.)

2 Sheets—Sheet 2.

FIG. 5.

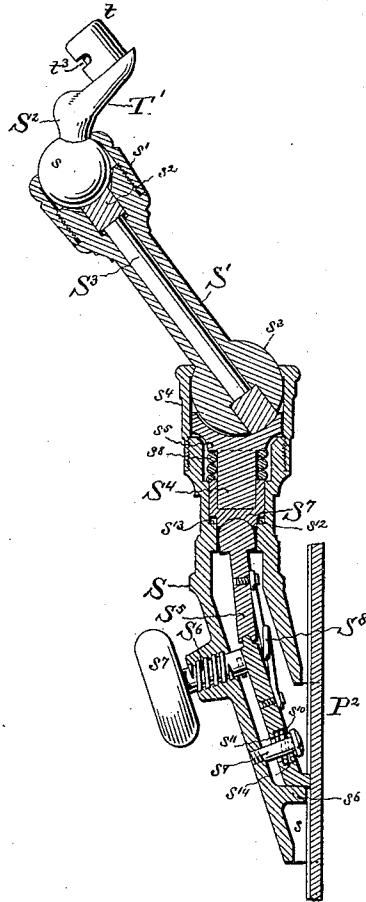
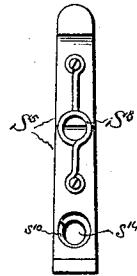

FIG. 6.



WITNESSES:

J. H. Anderson
J. H. Baile

INVENTOR:

Basil M. Wilkerson,
by Edw. F. Simpson, Jr.
Attorney.

UNITED STATES PATENT OFFICE.

BASIL M. WILKERSON, OF BALTIMORE, MARYLAND, ASSIGNOR TO THE S. S. WHITE DENTAL MANUFACTURING COMPANY, OF PHILADELPHIA, PENNSYLVANIA.

HEAD-REST.

SPECIFICATION forming part of Letters Patent No. 642,404, dated January 30, 1900.

Original application filed November 25, 1898, Serial No. 697,344. Divided and this application filed April 29, 1899. Serial No. 714,962. (No model.)

To all whom it may concern:

Be it known that I, BASIL M. WILKERSON, a citizen of the United States, residing in the city of Baltimore, in the State of Maryland, have invented certain new and useful Improvements in Head-Rests; and I do hereby declare the following to be a full, clear, and exact description of the invention, such as will enable others skilled in the art to which it appertains to make and use the same.

My invention relates to head-rests for dental chairs; and it consists of certain improvements in the head-rest proper and also in the support or carrier therefor. The said support or carrier is in some respects similar to the head-rest support or carrier shown, described, and claimed in United States Letters Patent No. 581,670, granted to me April 27, 1897.

The object of my present invention is to improve the head-rest support or carrier of said patent and at the same time provide an improved head-rest proper.

The present application is a division of my pending application, Serial No. 697,344, filed November 25, 1898.

In the accompanying drawings, which illustrate a suitable embodiment of my improvements, Figure 1 is a view in side elevation of the entire head-rest, including the head-rest proper and its support or carrier. Fig. 2 is a view in rear elevation of the same, with the head-rest pads omitted. Fig. 3 is a top or plan view of the head-rest proper. Fig. 4 is a view in front elevation of the lower section of the head-rest support or carrier. Fig. 5 is a central vertical sectional view of the head-rest support or carrier. Fig. 6 is a front or face view of the toggle-lever of the head-rest support or carrier detached.

As in my before-mentioned patent, the head-rest support or carrier consists of a jointed stem composed of three sections S, S', and S², united together by universal joints. The lower section S, which is tubular or hollow, is mounted and adapted to slide up and down on a dovetailed way P² of the back of a dental chair, a portion only of this dovetailed way being shown in Fig. 5, the section S being formed with a base portion grooved to fit upon and embrace the dovetailed way. To the up-

per section S is attached the supporting-bar T' of the head-rest proper, which will be more particularly referred to hereinafter. The intermediate section S' is connected to its two fellow sections by ball-and-socket joints. The upper section S² has a ball s on its lower end, which fits in a socket on the upper end of the intermediate section S', this socket being formed by a sleeve s', screwed upon the section S', and by the concave head s² of an endwise-movable presser-rod S³, fitted in the tubular intermediate section S'. The lower end of this section S' has a ball s³ on its lower end, which fits in a socket on the upper end of the lower section S. This socket is formed by a sleeve s⁴, screwed upon the section S, and the concave head s⁵ of an endwise-movable push-piece S⁴, fitted in the upper tubular or recessed end of the section S. The presser-rod S³ passes through and slightly beyond the ball s³ on the intermediate section S' and bears upon the concave surface of the head s⁵ of the push-piece S⁴.

Suitable mechanism is provided for clamping the head-rest carrier upon the dovetailed way P² and simultaneously clamping the ball-joints of the head-rest carrier together, whereby the head-rest carrier may be made rigid and the same locked to the back-pad carrier. This mechanism is shown as consisting of a toggle-lever S⁵, which acts to cause the push-piece S⁴ to clamp the ball s³ in its socket, the same movement being transmitted to the presser-rod S³ to clamp the ball s in its socket, the toggle-lever at the same time clamping the lower section S of the head-rest carrier to the dovetailed way P² of the chair-back. The toggle-lever S⁵ is placed in the section S in the position shown in Figs. 4 and 5, with its opposite ends bearing at the top against the push-piece S⁴ and at the bottom against an abutment s⁶ on the interior of this section. The end of the toggle-lever which bears against the abutment s⁶ is beveled, so that when the toggle-lever is straightened this beveled or wedge-shaped end will be forced against the dovetailed way P². A pressure-screw S⁶, provided with an external operating handle or knob s⁷, enters the section S through a suitable screw-threaded socket in a position

where its inner end will bear against the toggle-lever. By screwing in the pressure-screw it will straighten the lever, with the effect of forcing up the push-piece S^4 , and thus locking both joints of the head-rest carrier and the carrier to the chair-back.

It is desirable when the pressure-screw S^6 is operated to unclamp the joints of the head-rest carrier for the purpose of adjusting the head-rest that the various joints of the carrier be self-sustaining—that is to say, be yieldingly supported and yet not allowed to drop or move except when direct pressure is applied to the head rest or carrier. This self-sustaining adjustment or condition is required at all times for the universal or ball-and-socket joints of the carrier when the same is unlocked; but the joint between the vertically-adjustable carrier and the chair-back should be perfectly free when it is desired to adjust the carrier up or down, yet this lock should be self-adjusting when the universal joints are being adjusted. These important results are accomplished in the following manner: Fitted upon the lower end of the stem of the push-piece S^4 is a socketed slide-piece S^7 , adapted to slide upon the stem of said push-piece inside of a recess formed in the upper end of the lower section S of the head-rest carrier. One end of the toggle-lever bears against the slide-piece for pushing the push-piece upwardly, and a spring s^8 , surrounding the stem of the push-piece, is confined between the head of said push-piece and the upper end of the slide-piece S^7 and acts with a tendency to force the push-piece and the slide-piece apart. A shoulder S^{12} on the slide-piece S^7 , adapted to abut against a shoulder s^{13} on the section S , limits the downward movement of said slide-piece. A spring S^8 , preferably having a coil in it, is secured at its opposite ends to the respective members of the toggle-lever for the purpose of holding said members together without interfering with their free movement, yet at the same time insuring the bending or flexing of the toggle-lever when the same is not in action. The lower member of the toggle-lever S^5 has an opening s^{14} through it near its lower end, and a headed pin or bolt s^9 , projecting from the section S , enters said opening. A spring s^{10} surrounds the pin s^9 and is confined between the head of said pin and a shoulder s^{11} on the toggle-lever. The object of this spring is to insure the toggle-lever being released from frictional engagement with the dove-tailed way of the back-pad carrier when the pressure-screw is operated sufficiently to allow of this movement.

From the above description it will be understood that by screwing the pressure-screw in tightly the toggle-lever is caused to firmly lock the carrier to the back-pad carrier against vertical movement and to simultaneously firmly lock both universal joints of the carrier and that by unscrewing the pressure-screw to a certain extent all of the joints of the car-

rier are in a self-sustaining condition—that is to say, the spring s^8 is permitted to exert sufficient pressure on all the joints to render them tight enough to maintain the carrier in any position to which it may be moved, but leaving it in a condition to be adjusted by pressure applied to the head-rest or its carrier. By unscrewing the pressure-screw still farther the spring s^8 forces the slide-piece S^7 downwardly until its shoulder s^{12} abuts against the shoulder s^{13} of the carrier-section S , when the spring s^8 cannot act upon the toggle-lever. When in this condition, the universal joints are still self-sustaining, as before; but the joint between the carrier and the chair-back is relieved of all friction, and the carrier may be freely moved up and down without disturbing the adjustment of the universal joints.

The head-rest proper consists of two pads $T T'$, which are connected to the supporting-bar T' by means of compound or S -shaped clamp-links $T^2 T^2$. (See particularly Figs. 1 and 3.) These links are each provided with eyes or openings in their opposite ends, which fit upon studs or pivots t on the outer opposite ends of the supporting-bar and studs or pivots t' on the head-rest pads. In order to clamp the head-rest pads in their adjusted position, each link is provided with a clamp-screw T^3 , having an operating handle or knob T^4 , and which passes through an opening in one end of the link and through an opening in the body of the link and screws into the opposite end of the link. Screws t^2 , screwing in the links and entering slots t^3 in the studs t , serve to prevent the links from accidentally coming off the studs and at the same time limit the turning movement of said links about said studs. The pads may be kept in place on the links by means of a pin or spring in each link engaging an annular groove in each stud t' of the pads. This construction enables the links to turn about their pivotal connection with the supporting-bar in a line with the plane of said bar or toward and away from each other and the head-rest pads to turn about their pivotal connection with the links, whereby a very wide range of adjustment of the head-rest is permitted. Another advantage of this construction is that the pads are readily detachable from their clamp-links and may be reversed.

It will of course be understood that the details of construction herein shown and described may be varied without departing from the spirit or scope of my invention and that the particular head-rest proper may be used in connection with any suitable support or carrier and that the particular support or carrier may likewise be used in connection with any suitable form of head-rest proper.

I claim as my invention—

1. The combination of a head-rest-supporting stem or carrier composed of sections, universal joints between the sections of said stem, a handle located upon one of the sections,

means controlled by said handle for locking all of said joints simultaneously and by one movement of the handle, and means for yieldingly supporting the stem when the joints have been unlocked by the handle, substantially as and for the purpose described.

2. In combination with a chair-back, a head-rest-supporting stem or carrier composed of sections, universal joints between the sections of said stem, a vertically-sliding connection between the lower section of said stem and said chair-back, means for simultaneously locking said universal joints and said vertically-sliding connection, and means for yieldingly clamping said joints and said connection, when said locking means are unlocked, substantially as and for the purpose described.

3. In combination with a chair-back, a head-rest-supporting stem composed of sections, universal joints between the sections of said stem, a vertically-sliding connection between the lower section of said stem and a chair-back, a handle located upon said lower section, means under the control of said handle for simultaneously locking said universal joints and said vertically-sliding connection, means for yieldingly clamping said universal joints when said locking means are unlocked, and means, also under the control of said handle, for either yieldingly clamping said vertically-sliding connection or leaving the same free, substantially as and for the purpose described.

4. The combination with a chair-back, of a head-rest-supporting stem composed of sections, ball-and-socket joints between the sections of said stem, a vertically-sliding connection between the lower section of said stem and said chair-back, means carried by said lower section for rigidly clamping the same

in its position of vertical adjustment on said chair-back, a push-piece mounted in the upper end of said lower section for clamping the ball-and-socket joint between said lower section and the section connected thereto, a slide-piece located between said push-piece and said means for clamping the stem to the chair-back for transmitting locking or clamping pressure from said clamping means to said ball-and-socket joint, and a spring acting with a tendency to force said push-piece and said slide-piece away from each other, substantially as and for the purpose described.

5. The combination in a head-rest, of an adjustable supporting stem or carrier, a supporting-bar adjustably connected midway its length to said supporting stem or carrier, studs projecting at right angles from the opposite ends of said supporting-bar, two clamp-links each of which is fitted at one end to swivel about the respective studs of the supporting-bar, whereby said links are capable of being rocked in a line with the plane of said supporting-bar or toward and away from each other, two head-rest pads each pivoted to the outer end of the respective clamp-links, whereby said pads are capable of being rocked in the line of movement of said clamp-links, and means for simultaneously clamping and unclamping the pivotal connections of each clamp-link and its respective head-rest pad and stud of the supporting-bar, the clamping means for one link being independent of the clamping means for the other link, substantially as described.

In testimony whereof I affix my signature in presence of two witnesses.

BASIL M. WILKERSON.

Witnesses:

FRANK W. WAGNER,

S. C. MALONE.