



(86) **Date de dépôt PCT/PCT Filing Date:** 2013/04/25
 (87) **Date publication PCT/PCT Publication Date:** 2013/10/31
 (85) **Entrée phase nationale/National Entry:** 2014/10/24
 (86) **N° demande PCT/PCT Application No.:** US 2013/038145
 (87) **N° publication PCT/PCT Publication No.:** 2013/163381
 (30) **Priorité/Priority:** 2012/04/26 (US13/456,435)

(51) **Cl.Int./Int.Cl. A61B 6/12** (2006.01),
A61N 5/10 (2006.01)
 (71) **Demandeur/Applicant:**
FOCAL THERAPEUTICS, INC., US
 (72) **Inventeurs/Inventors:**
DREWS, MICHAEL J., US;
HERMANN, GEORGE D., US;
LEBOVIC, GAIL J., US;
STUBBS, JAMES B., US;
WILLIS, DAVID, US
 (74) **Agent:** BORDEN LADNER GERVAIS LLP

(54) **Titre : IMPLANT CHIRURGICAL POUR LE MARQUAGE D'UN TISSU MOU**
 (54) **Title: SURGICAL IMPLANT FOR MARKING SOFT TISSUE**

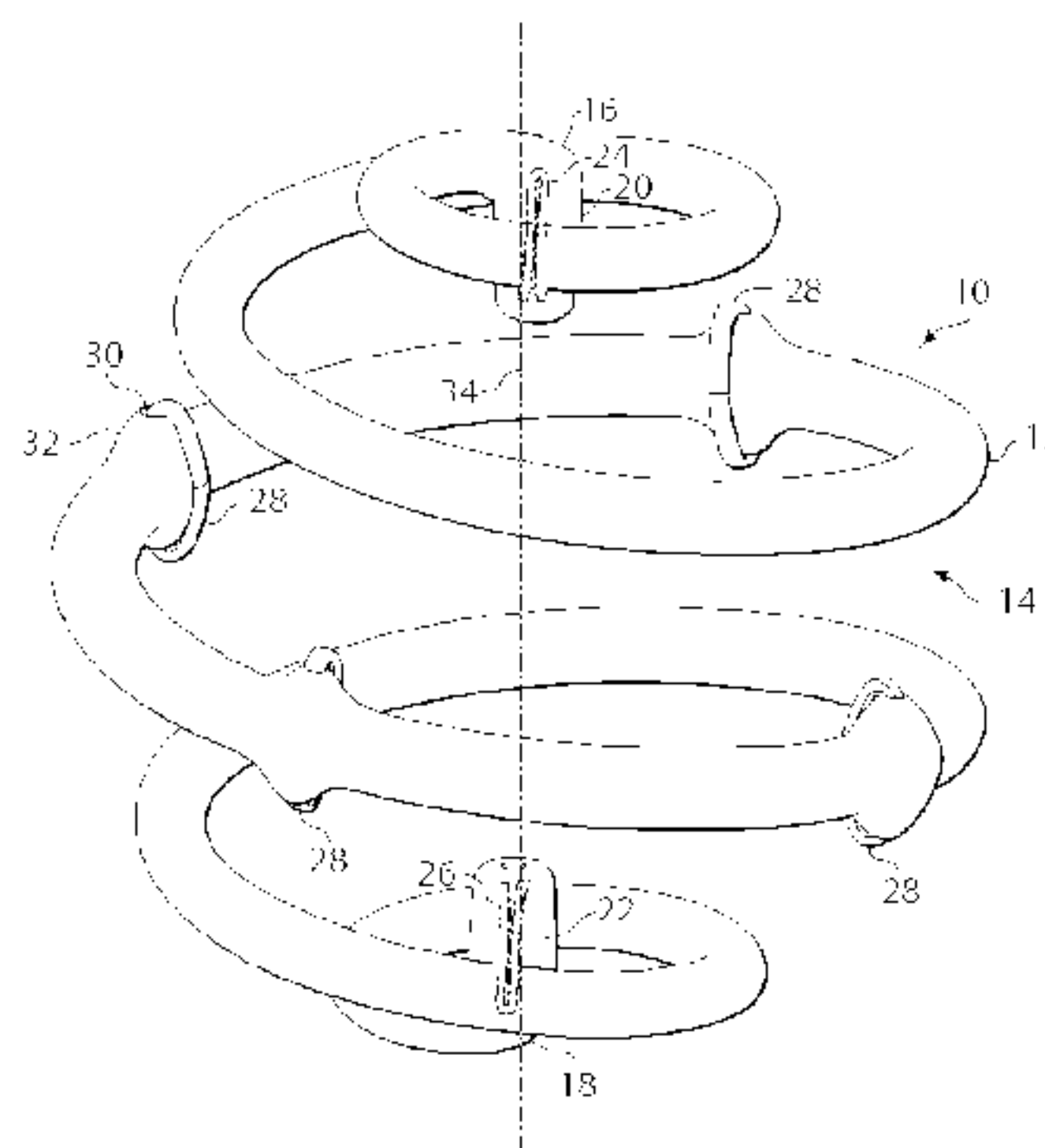

Fig. 1A

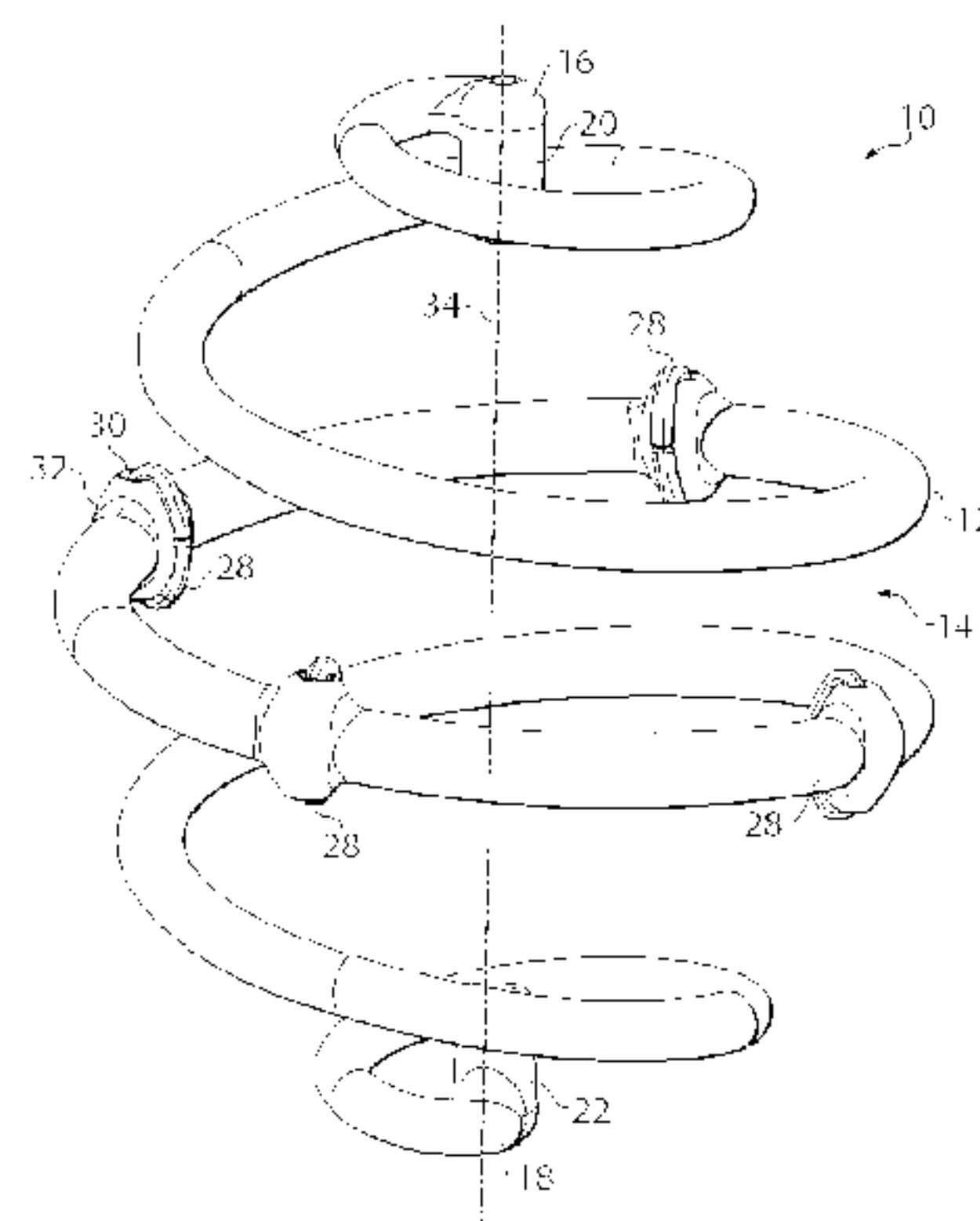

Fig. 1B

(57) **Abrégé/Abstract:**

An implantable tissue marker device is provided to be placed in a soft tissue site through a surgical incision. The device can include a bioabsorbable body in the form of a spiral and defining a spheroid shape for the device, the spiral having a longitudinal axis, and

(57) Abrégé(suite)/Abstract(continued):

turns of the spiral being spaced apart from each other in a direction along the longitudinal axis. A plurality of markers can be disposed on the body, the markers being visualizable by a radiographic imaging device. The turns of the spiral are sufficiently spaced apart to form gaps that allow soft tissue to infiltrate between the turns and to allow flexibility in the device along the longitudinal axis in the manner of a spring.

(12) INTERNATIONAL APPLICATION PUBLISHED UNDER THE PATENT COOPERATION TREATY (PCT)

(19) World Intellectual Property
Organization
International Bureau(10) International Publication Number
WO 2013/163381 A1(43) International Publication Date
31 October 2013 (31.10.2013)(51) International Patent Classification:
A61B 5/05 (2006.01)

(21) International Application Number:

PCT/US2013/038145

(22) International Filing Date:

25 April 2013 (25.04.2013)

(25) Filing Language:

English

(26) Publication Language:

English

(30) Priority Data:

13/456,435 26 April 2012 (26.04.2012) US

(71) Applicant: **FOCAL THERAPEUTICS, INC.** [US/US];
4370 Alpine Road #101, Portola Valley, CA 94028 (US).(72) Inventors: **DREWS, Michael J.**; 480 Jacobs Lane, Palo
Alto, CA 94306 (US). **HERMANN, George D.**; 185 EchoLane, Portola Valley, CA 94028 (US). **LEBOVIC, Gail J.**;
4817 Cypress Point, Frisco, TX 75034 (US). **STUBBS,**
James B.; 13010 Bethany Road, Alpharetta, GA 30004
(US). **WILLIS, David**; 85 College Avenue, Palo Alto, CA
94306 (US).(74) Agents: **CAHILL, Ronald E.** et al.; Nutter McClellan &
Fish LLP, Seaport West, 155 Seaport Boulevard, Boston,
MA 02210-2604 (US).(81) Designated States (*unless otherwise indicated, for every
kind of national protection available*): AE, AG, AL, AM,
AO, AT, AU, AZ, BA, BB, BG, BH, BN, BR, BW, BY,
BZ, CA, CH, CL, CN, CO, CR, CU, CZ, DE, DK, DM,
DO, DZ, EC, EE, EG, ES, FI, GB, GD, GE, GH, GM, GT,
HN, HR, HU, ID, IL, IN, IS, JP, KE, KG, KM, KN, KP,
KR, KZ, LA, LC, LK, LR, LS, LT, LU, LY, MA, MD,
ME, MG, MK, MN, MW, MX, MY, MZ, NA, NG, NI,

[Continued on next page]

(54) Title: SURGICAL IMPLANT FOR MARKING SOFT TISSUE

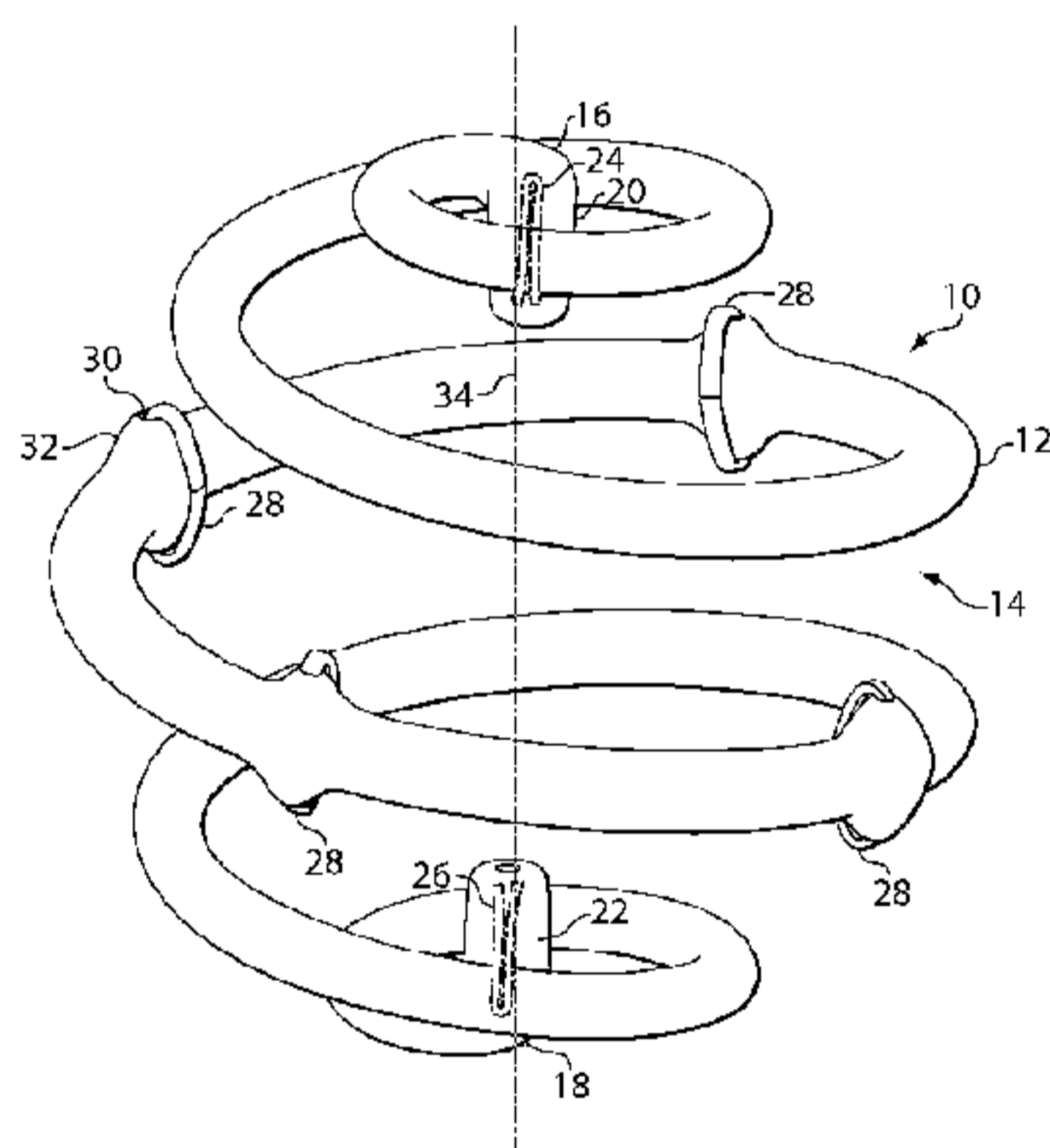

Fig. 1A

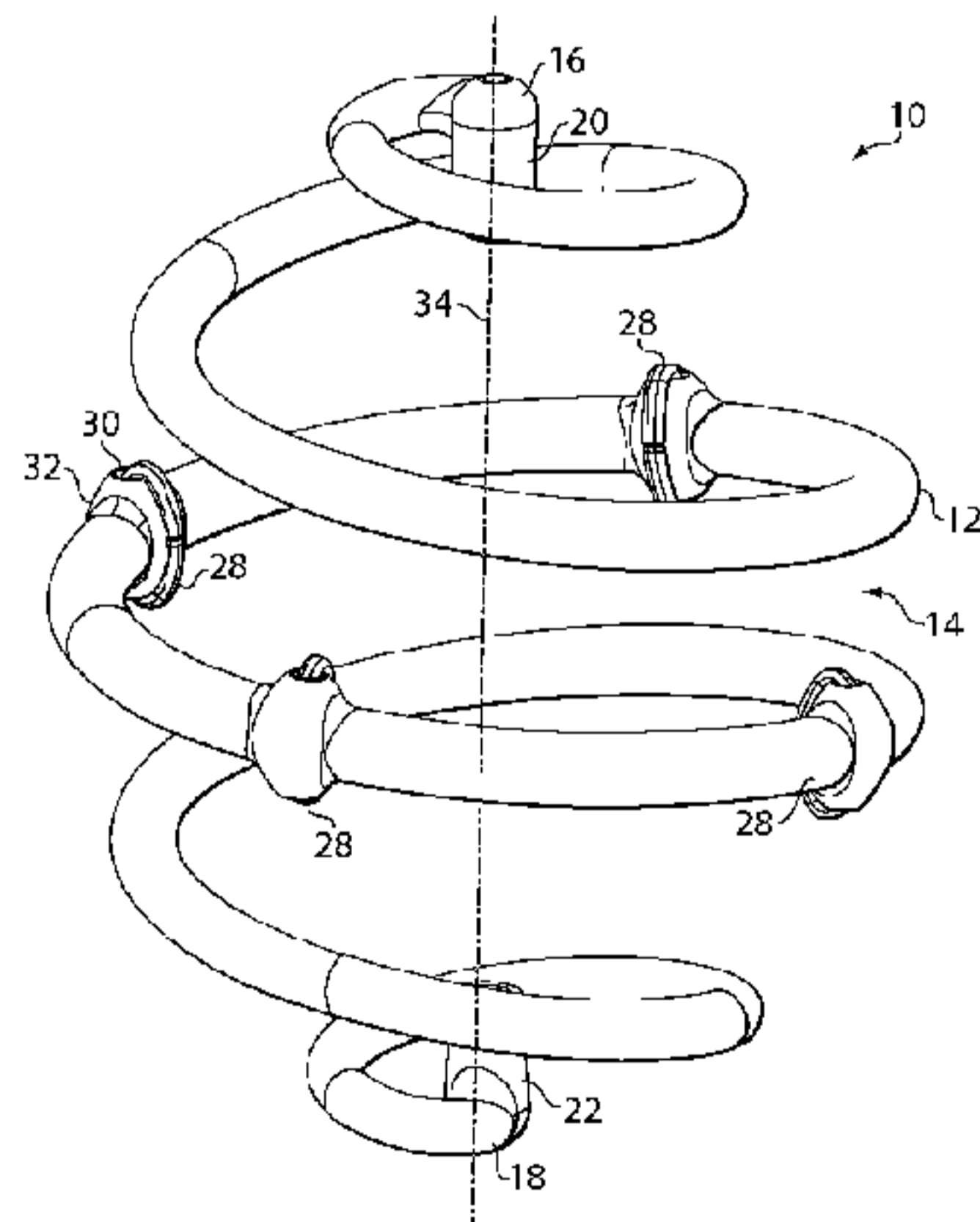

Fig. 1B

(57) Abstract: An implantable tissue marker device is provided to be placed in a soft tissue site through a surgical incision. The device can include a bioabsorbable body in the form of a spiral and defining a spheroid shape for the device, the spiral having a longitudinal axis, and turns of the spiral being spaced apart from each other in a direction along the longitudinal axis. A plurality of markers can be disposed on the body, the markers being visualizable by a radiographic imaging device. The turns of the spiral are sufficiently spaced apart to form gaps that allow soft tissue to infiltrate between the turns and to allow flexibility in the device along the longitudinal axis in the manner of a spring.



WO 2013/163381 A1

WO 2013/163381 A1

NO, NZ, OM, PA, PE, PG, PH, PL, PT, QA, RO, RS, RU, RW, SC, SD, SE, SG, SK, SL, SM, ST, SV, SY, TH, TJ, TM, TN, TR, TT, TZ, UA, UG, US, UZ, VC, VN, ZA, ZM, ZW.

(84) Designated States (*unless otherwise indicated, for every kind of regional protection available*): ARIPO (BW, GH, GM, KE, LR, LS, MW, MZ, NA, RW, SD, SL, SZ, TZ, UG, ZM, ZW), Eurasian (AM, AZ, BY, KG, KZ, RU, TJ,

TM), European (AL, AT, BE, BG, CH, CY, CZ, DE, DK, EE, ES, FI, FR, GB, GR, HR, HU, IE, IS, IT, LT, LU, LV, MC, MK, MT, NL, NO, PL, PT, RO, RS, SE, SI, SK, SM, TR), OAPI (BF, BJ, CF, CG, CI, CM, GA, GN, GQ, GW, ML, MR, NE, SN, TD, TG).

Published:

— *with international search report (Art. 21(3))*

SURGICAL IMPLANT FOR MARKING SOFT TISSUE

RELATED APPLICATIONS

[0001] This application incorporates by reference United States patent publication no. 2009-0024225-A1, entitled "Implant for Targeting Therapeutic Procedure," filed on July 16, 2008, which application is incorporated herein by reference in its entirety.

[0002] This application incorporates by reference United States patent publication no. 2011-0004094 A1, entitled "Bioabsorbable Target for Diagnostic or Therapeutic Procedure," filed on May 28, 2010, which application is incorporated herein by reference in its entirety.

BACKGROUND

[0003] Two trends have become significant in driving the delivery of medical treatments: First, treatments, be they drugs, energy or surgery, are moving towards local and more precise (i.e., focused) delivery, and second, treatments are being tailored and optimized for each patient based on their specific anatomy, physiology and disease features. These directions both are designed to minimize the likelihood of adverse effects from the therapies as well as provide a more patient-specific treatment, which may improve disease-free survival rates and/or improve/decrease local recurrence of disease.

[0004] Many of these trends have been adopted in the surgical environment where large, open surgical procedures have been and continue to be replaced by laparoscopic techniques and other minimally invasive procedures. Drug therapies are moving toward more localized delivery as well, such as treatments that are placed directly at or near the treatment site (e.g., drug eluting stents and GLIADEL wafers for brain tumors). Until recently, the desire to do the same in radiation therapy has been hampered by inadequate technology for focused delivery. However, significant progress in the delivery of radiation to a more localized region of treatment (i.e., localized radiation delivery) has become popularized in the field of brachytherapy, a subspecialty of radiation oncology, most notably used in the treatment of prostate, breast, and gynecologic cancer patients. As an example, in breast brachytherapy, the radiation source is temporarily inserted into one or more catheters that are temporarily placed and held within the breast at the site where the tumor has been removed. The prescribed dose of radiation is calculated and customized for each patient, and is delivered directly to the area at highest risk of local recurrence. This system allows for

more accurately directed treatment, which is effectively delivered from the “inside out.” This approach has gained popularity because it offers a number of benefits to patients undergoing treatment for breast cancer including delivery of the equivalent dose of radiation in a shorter timeframe (normally 5-7 days vs. daily for up to 6 weeks) and delivery to a smaller volume of the breast tissue (i.e., accelerated and smaller volume treatments). Thus, by delivering a customized and focused amount of radiation, the therapeutic advantage is maintained while the potential damage to surrounding normal tissues is minimized.

[0005] Although brachytherapy is gaining acceptance throughout the world, external beam radiation therapy (EBRT) remains the most common method of delivery for radiation therapy. EBRT is used in the treatment of many different types of cancers, and can be delivered before, during and/or after surgery. In addition, chemotherapy is often utilized in conjunction with radiation therapy. EBRT is delivered to cancer patients as either the first line of therapy (for non-resected cancers) or as a means of maximizing local control of the cancer following surgical removal of the tumor. The radiation is meant to help “sterilize” the area of tumor resection in an effort to decrease the potential for recurrent disease.

[0006] In EBRT, one or more beams of high energy x-rays are aimed at the part of the body needing treatment with radiation. A linear accelerator (often called a linac) produces the beams and has a collimator that helps to shape the beams as they exit the linac. It is very common for two or more beams to be used, each of which is delivered from different directions around the area of the tumor or the site of tumor resection. Often, in planning the delivery of the radiation, the beams are directed so that they will intersect at the tumor site, thereby focusing the highest dose of radiation at the most critical area. In this manner, the normal tissues surrounding the target are exposed to lower amounts of radiation. At the same time, the exact target site receives a more precise and accurately delivered dose, since the sum of the treatment beams are greatest at the directed tumor target. The tumor target volume is the region delineated by the radiation oncologist using CT scans (or other imaging methods such as ultrasound or MRI) of the patient. The tumor target volume and radiation dose prescription parameters are entered into a treatment planning computer. Treatment planning software (TPS) then produces a plan showing how many beams are needed to achieve the radiation oncologist’s prescription dose, as well as the size and shape of each beam.

[0007] Historically, EBRT is practiced by dividing the total radiation dose into a series of smaller more tolerable doses which are delivered to the patient sequentially. Dosage is typically limited by the tolerance of normal tissues surrounding the site to be treated. Hence, often, the radiation therapy is continued until side effects become intolerable to the patient. The target volume, in which it is desired to deliver essentially 100% of the prescribed radiation dose, has historically been defined as the tumor (the gross tumor volume, or GTV) plus a surrounding volume of tissue margin that may harbor remaining microscopic tumor cells (the clinical target volume, or CTV). Another margin of surrounding normal tissue is added to the CTV to account for errors in positioning of the patient for therapy and movement of the tumor site both during a fraction and between fractions.

[0008] In the treatment of breast cancer, the complete course of EBRT is divided (fractionated) into numerous small, discrete treatments each of which is referred to as a “fraction”. A typical prescribed dose of 60 Gray (Gy) is fractionated into 30 daily treatments of 2 Gy per day. During a fraction, the treatment beam may be “on” for ~ 1 minute. Thus, to achieve the full treatment dose, the radiation therapy is typically delivered 5 days per week over a 6 week period. In the treatment of breast, lung, chest and upper abdominal (e.g. pancreatic) cancers the delivery of radiation therapy must take into consideration the changes in tissue position during respirations which may alter the position of the target tissue.

[0009] Another common procedure in which EBRT is used is whole breast radiation, typically used as a radiation therapy regimen following surgical lumpectomy as treatment for breast cancer. In this form of therapy, the entire breast is irradiated multiple times in small dose fractions over a course of treatment that typically lasts about 1-2 months. In addition to these whole breast doses, most patients receive an additional “boost” dose that is given to the area immediately surrounding the lumpectomy cavity, as this region is suspected to be of higher risk of recurrence. Often there is difficulty and uncertainty in identifying the exact tissue location of this post-lumpectomy tissue region. As a result of this uncertainty, larger tissue volumes than would otherwise be necessary are defined for boost treatment to ensure that the correct “high risk” target tissue indeed receives the boost dose. In addition, as the boost target is smaller than the whole breast that was treated, the actual “targeted” boost tissue volume is smaller than the whole breast target and can be more difficult to specifically target or define for treatment.

[00010] In the last few years, the treatment planning software and linear accelerator technology have dramatically improved in their ability to shape the radiation therapy beams to better avoid nearby sensitive structures (also known as “organs at risk” or non-target tissues). The latest treatment planning software allows the radiation oncologist and medical physicist to define the volume of tissue to be treated using CT scans and provide therapy constraints (e.g., minimum radiation dose inside the target volume, maximum radiation dose to structures nearby target volume). The software then automatically computes the beam angles and shapes in a process called inverse treatment planning. This process can be even further refined using a technique called Intensity Modulated Radiation Therapy (IMRT) which shapes the beam of radiation. Another feature of the newer linear accelerators is a type of radiographic (and/or ultrasonic) imaging that is used to better position the patient and his/her tumor for more accurate targeting of the treatment beams. This latter method is called Image Guided Radiation Therapy, or IGRT.

[00011] Both IMRT and IGRT techniques use numerous, smaller and more precisely shaped beams that intersect at the target volume. IGRT differs from IMRT in at least one important aspect – imaging prior to each fraction is used to reduce positioning errors and make sure the treatment beam is properly targeted. Typically, IGRT uses bony anatomy (e.g., pelvic bones for prostate patients) for radiographic targeting and soft tissue interfaces (e.g., prostatic capsule and bladder wall) for ultrasound targeting. Rarely, implanted radio-opaque markers (e.g., VISICOIL) have been used to facilitate targeting for IGRT. However, using a single marker device that defines in a 3 dimensional/volumetric manner the limits or margins of treatment has not yet been accomplished. In the treatment of breast cancer specifically, some clinicians have attempted to help delineate the margins of the lumpectomy cavity by using radio-opaque markers such as surgical clips placed at the time of surgery. This, in theory, may help the radiation oncologist in treatment planning, however, often these clips are inaccurate in their placement, have a tendency to migrate postoperatively (e.g., due to their mobility and other healing and scarring issues), and may be confused with other surgical clips used for haemostatic control during surgery. Tissue changes and scarring can markedly affect the position of these clips, thus leading to the possibility of inaccurate targeting of the radiation. In addition, these markers have not been used with significant success for targeting in the newer delivery methods, such as for each fraction or each beam of every fraction as is done in IGRT.

[00012] IMRT uses a special type of collimator, a multi-leaf collimator (MLC) that changes the shape of the beam during each fraction to modulate or “sculpt” the radiation dose to more closely fit the actual target volume shape in three dimensions. Linear accelerators equipped with MLCs can control the size and shape of the beam to within a few millimeters accuracy. However, to best take advantage of their precision, the tissue target needs to be accurately defined in 3 dimensions.

[00013] IGRT is a relatively new option on linear accelerators, however many new linacs are available today that have on-board imaging capability via mega-voltage (MV) or kilo-voltage (KV) x-rays/fluoroscopy. The on-board imaging capability can also be retrofitted to existing equipment. On-board imaging is a technical capability that has been introduced into the newest linac product lines by major manufacturers of linear accelerators (e.g., Varian Medical Systems, Elekta, Tomotherapy, Accuray and Siemens). While the technology made by these companies provides the possibility of performing better targeting for external beam radiation therapy, the targets (e.g., bony anatomy) are inadequate in order to achieve a precise and accurate target region for precision treatment of a specific tissue region, often because of inaccuracies associated with correlating bony anatomy to the adjacent soft tissue target region.

[00014] As described above, targeting the external beam radiation therapy accurately requires one to point out the target using markers known as “fiducials.” These fiducial markers have different radiographic properties than that of the surrounding tissue (e.g., bone, and soft tissue). To date, this has been accomplished using radio-opaque markers (e.g., permanently implanted foreign bodies). Alternatively, Patrick and Stubbs described a device and method for shaping and targeting EBRT using a temporarily implanted balloon catheter (U.S. patent no. 7,524,274). This device and method required implantation of a foreign body whose removal necessitated a second medical/surgical procedure. There is clinical evidence suggesting that the implantation and irradiation of an area of the breast surrounding an implanted balloon can result in long-standing complications such as persistent seroma (collection of fluid within the breast that may become infected). There are a number of clinical difficulties that preclude use of a balloon-type device as a realistic/good option to define a tissue target for radiation. For example, a balloon device may interfere with the EBRT treatment since the balloon and its contents may affect the transmission of the EBRT, and therefore may affect the dose of radiation reaching the target tissue. In addition, the

balloon may inhibit tissue growth back into the cavity during the healing process, which can lead to irregular and unsightly scarring, which is particularly undesirable following breast surgery for cancer. The balloon can be uncomfortable to the patient during the course of treatment, and thus, use of a balloon-type device for targeting radiation therapy has not been useful in the clinical domain.

[00015] Hence, the need exists for a better fiducial marker device and method for more accurately defining the target tissue volume and providing an imageable target for the external beam treatments, without requiring subsequent removal.

SUMMARY

[00016] The invention described herein uses implantable devices that can allow for more accurate targeting of external beam radiation to the region of tissue that is to be treated. The devices provide a 3-dimensional target or group of targets that is used to focus the radiation therapy treatment beams directly onto the targeted tissue – for example, the tissue surrounding a tumor resection cavity. The device may be formed of an absorbable material that is implanted intraoperatively during the same surgical procedure as the tumor resection and requires no second procedure to remove (it is resorbed *in situ* in the patient's body).

[00017] In a first aspect, an implantable fiducial tissue marker device is provided for placement in a soft tissue site through an open surgical incision. The device includes a bioabsorbable body formed whose outer regions define a peripheral boundary of the marker device. A plurality of visualization markers are secured to the body so that visualization of the marker device using medical imaging equipment will indicate the 3-dimensional location of the tissue site. The device is also conformable to the adjacent soft tissue and its peripheral boundary is able to be penetrated by adjacent soft tissue during its use.

[00018] In specific embodiments, the bioabsorbable body is in the shape of a spiral where the spiral has a longitudinal axis and turns of the spiral are spaced apart from each other in a direction along the longitudinal axis. The peripheral boundary of the device can have a shape selected from the group consisting of spherical, scalene ellipsoid, prolate spheroid, and oblate spheroid shape. The device can also have a north polar region and a south polar region at opposed ends of the longitudinal axis. A strut can further be connected

between the north polar region and the south polar region. The strut can include a sliding element to allow the spiral body to be compressed in the manner of a spring.

[00019] Visualization markers can be attached to the body in the north polar region and/or the south polar region. A plurality of visualization markers can also be attached to the body about an equatorial region of the substantially spheroid device. In one embodiment, at least four visualization markers are attached to the body about its equatorial region. At least some of the visualization markers can be radio-opaque clips. The radio-opaque clips can be attached to the body using preformed holes in the body into which the clips can be pressed and attached.

[00020] In a further aspect, a method for fabrication of a tissue marker device is provided. The device can be fabricated using injection molding to form a body made of a bioabsorbable polymer in a planar configuration. The body can be heat formed so that the body is reconfigured from a planar configuration to a three dimensional configuration.

[00021] In specific embodiments, fabrication of the device can include forming pockets or through-holes in the body during injection molding and attaching visualization markers to the pockets or through-holes. The injection molded body can include north and south polar regions, with each polar region including a polar extension that is directed toward an interior of the device. Fabrication can further include connecting a strut to the polar extensions. The strut can be slideably connected to at least one of the polar extensions. Also, two or more separate parts can be connected to achieve a finished product.

[00022] In a still further aspect, an implantable tissue marker device is provided to be placed in a soft tissue site through a surgical incision. The device can include a bioabsorbable body in the form of a spiral and defining a spheroid shape for the device, the spiral having a longitudinal axis, and turns of the spiral being spaced apart from each other in a direction along the longitudinal axis. A plurality of markers can be disposed on the body, the markers being visualizable by a radiographic imaging device. The turns of the spiral are sufficiently spaced apart to form gaps that allow soft tissue to infiltrate between the turns and to allow flexibility in the device along the longitudinal axis in the manner of a spring.

[00023] In specific embodiments, the device can have a spring constant in the direction of the longitudinal axis between about 5 and 50 grams per millimeter. The bioabsorbable

body can include opposed polar regions along the longitudinal axis. Markers can be placed in each of the polar regions. A plurality of markers can also be placed along an equatorial region of the body. In one embodiment, at least four markers are placed along the equatorial region.

BRIEF DESCRIPTION OF THE DRAWINGS

[00024] The invention will be more fully understood from the following detailed description taken in conjunction with the accompanying drawings:

[00025] FIG. 1A and B illustrate a spiral implant device of the invention;

[00026] FIG. 2 illustrates a spiral implant device of the invention having a central strut;

[00027] FIG. 3 illustrates a spiral implant device of the invention having a central strut, with marker clips secured within the spiral body;

[00028] FIG. 4 A and B illustrate stages of fabrication for a spiral implant device of the invention;

[00029] FIG. 5 illustrates a stage of fabrication for a spiral implant device of the invention;

[00030] FIG. 6 illustrates a further stage of fabrication for a spiral implant device of the invention;

[00031] FIG. 7 illustrates an alternate embodiment of a spiral implant device of the invention;

[00032] FIGS. 8A and B illustrate an additional embodiment of an implant device of the invention;

[00033] FIGS. 9A, B, C and D illustrate an additional embodiment of an implant device of the invention;

[00034] FIGS. 10A, B, C, and D illustrate an additional embodiment of an implant device of the invention;

[00035] FIG. 11 illustrates an embodiment of an implant device that has been placed in a surgical resection cavity;

[00036] FIG. 12 illustrates another embodiment of an implant device that has been placed in a surgical resection cavity;

[00037] FIG. 13 illustrates another embodiment of an implant device that has been placed in a surgically created breast lumpectomy cavity;

[00038] FIG. 14 illustrates another embodiment of an implant device that has been placed in a surgical resection cavity;

[00039] FIG. 15 illustrates an additional embodiment of an implant device of the invention;

[00040] FIGS. 16A, B, and C illustrate sizing tools with corresponding spiral implant devices of the invention;

[00041] FIGS. 17A and B illustrate additional 2-dimensional embodiments of an implant device of the invention;

[00042] FIG. 18 illustrates an alternative 2-dimensional embodiment of an implant device of the invention; and

[00043] FIG. 19 illustrates an idealized tumor resection cavity in soft tissue as is known in the prior art.

DETAILED DESCRIPTION

[00044] The invention described herein uses implantable devices that can allow for more accurate targeting of external beam radiation to the region of tissue that is to be treated. The devices provide a 3-dimensional target or group of targets that is used to focus the radiation therapy treatment beams directly onto the targeted tissue – for example, the tissue surrounding a tumor resection cavity. The device may be formed of an absorbable material that is implanted intraoperatively during the same surgical procedure as the tumor resection and requires no second procedure to remove (it is resorbed *in situ* in the patient's body).

[00045] In one embodiment, the invention includes a spiral, bioabsorbable surgical implant 10 (illustrated in Figure 1A in a spherical configuration and in Figure 1B in an ellipsoid configuration) with at least one integral targeting marker component that is visible by means of clinical imaging (radiographic, ultrasonic, MRI, etc.). In many embodiments, the implant 10 has a relatively non-complex peripheral shape that can facilitate easy target delineation, such as spheres, ellipsoids, or cylinders. In this way, the implant (and /or the markers affixed thereto) can be visualized, and its contours (and thus the contours of the target tissue to be treated – typically marginal regions surrounding an excised tumor) can be readily determinable. Treatment can then be applied to the target tissue. The size and shape of the implant can be varied to correspond to the most common resection cavity sizes and shapes. The device may be flexible and may be in its predetermined shape before placement and although it may tend toward that predetermined shape after implantation, the implant is subject to the forces applied to it by the patient's tissue and hence its shape is able to deform and conform to the adjacent tissue as well. Similarly, the device may become integrated into the surrounding tissue as it is absorbed by the body, leaving the markers in proximity of the previously excised tumor for future clinical tracking. The device can be sized as needed for a particular surgery, however, preferred sizes range from about 2 cm to about 6 cm in longest diameter.

[00046] As illustrated in Figures 1A and 1B, the surgical implant 10 of the invention is formed as a spiral. The spiral nature can permit the implant 10 to be more flexible than it otherwise might be. For example, the implant 10 can flex along its axis 34 in length in the manner of an extension or compression spring or bend along its axis 34 in the manner of bendable coil spring. In addition, the lack of continuous walls can allow the implant to flex in directions other than along its axis. Such flexibility can allow for the target tissue, and the cavity into which the implant 10 is placed, to flex as the patient moves, making the implant more comfortable for the patient. In addition, the open nature of the spiral can allow tissue growth and insinuation into the cavity which may reduce the incidence or effects of seroma, and in some instances may be able to reduce the volume of the target to be irradiated.

[00047] The shape of the illustrated implant 10 in Figure 1A is spherical, however, the implant could also be made in other shapes, such as a football-shaped ellipsoid (illustrated in Figure 1B) or cylindrical. As used herein, the term “spheroid” is expressly intended to include both spherical and ellipsoid shapes for the implant 10 – as such, both the

embodiments of Figure 1A and Figure 1B are spheroid. The choice of shape may depend on the shape and nature of the cavity into which the implant 10 is being placed. In the case of a lumpectomy cavity commonly related to breast cancer, a relatively spherical shape is a common choice.

[00048] While the implant 10 could have any shape, regular shapes that are readily modeled by external radiation beam treatment devices are preferred. Such shapes can include spherical, scalene ellipsoid, prolate spheroid, and oblate spheroid shapes. Again, the use of the term “spheroid” herein is intended to include all of these spherical and ellipsoid shapes. Other regular shapes such as cylinders or squares could also be used, however, sharp corners might make it more difficult to shape radiation doses to the target tissue. In general, the implant 10 can have polar regions with an open framework extending between the polar regions. Such an open framework would include a body 12 that provides sufficient stability to mark the boundaries of a tumor resection cavity, while having sufficient gaps 14 in the body to allow tissue around the cavity to infiltrate the device. In this illustrated embodiment, the shape of the implant 10 is created by a continuous or one-piece body 12 that is formed into a spiral having gaps 14 between the turns of the spiral, the overall spiral having a spherical shape with polar regions 16, 18. In each polar region 16, 18, there is an extending portion 20, 22, which, in this embodiment, extends inward toward the center of the spherical shape.

[00049] In addition, the open framework can be designed to provide specific levels of flexibility. As noted elsewhere herein, the illustrated spiral design acts as a spring. By varying the rigidity of the material making up the body 12, and/or by varying the thickness of body 12, a spring constant for the device 10 can be varied to achieve a desired flexibility. That is, by design the spring constant may provide a certain amount of force in order to keep the markers in their position along the margins of the cavity, but allow sufficient flexibility for patient comfort and to minimize scarring, therefore the device 10 can be optimized for its intended purposes. Preferred embodiments for use in treating breast cancer include those having a spring constant (denoted as “k”, in units of grams/mm) between about 5 and 15 grams per millimeter axial deflection for the 4 cm diameter devices (more preferably 8-12 g/mm), between about 10 and 25 g/mm axial deflection for the 3cm diameter devices (more preferably 15-20 g/mm) , and between about 25 and 70 grams/mm axial deflection for the

2cm devices (more preferably 30-50 g/mm). The inventors have discovered that it can be beneficial to have higher k values for smaller diameter devices.

[00050] Typical sizes of the device range from 2-6cm in equatorial diameter and 2-8cm in length. It is useful for the clinician to have a range of product diameters and lengths to choose from to provide the optimal configuration for a given patient.

[00051] The implant 10 is preferably able to be visualized on a medical imaging apparatus so that it can be used for targeting therapy. In the illustrated embodiment, visualization characteristics may be enhanced by providing by visualization markers in the form of radio-opaque clips 24, 26, 28 that provide high contrast visibility on imaging devices. In the illustrated configuration, a first clip 24 is provided at the “north pole”, a second clip 26 is provided at the “south pole”, and four clips 28 are distributed substantially around the equatorial region of the spherical implant 10. This clip array permits a specific outlining, or in other words a characterization of the extent of the borders of the tissue cavity in all 3 dimensions, and in this embodiment, the xy, zy and xz planes. More or fewer clips can be used to provide more detailed or less detailed tissue site identification, as needed. Given the flexibility and shape of implant 10 as described and illustrated, clips are preferentially provided at the two poles and also in some number distributed substantially about the equator, or elsewhere along its spiral length. In this manner, even where the spherical implant flexes *in vivo*, or the tissue around the cavity moves or flows, the 3 dimensional shape of the tissue region can be identified, based on the location of the clips. It is worth noting that, with currently available high resolution imaging systems, including CT, mammography, MRI, and ultrasound, the presence of the clips may not be necessary to image the implant and hence image the surrounding soft tissue. The mere presence of the bioabsorbable body, which need not contain air gaps in the body material, can in some cases, be sufficient to delineate or demarcate the desired tissue location.

[00052] As illustrated, each of the north and south pole clips 24 and 26 is located within the respective polar region extension 20, 22. Each of the clips is secured to the body material. In this embodiment, the polar clip is configured as a wire element that is folded onto itself, with the wire ends slightly flared prior to assembly. During assembly the clip is inserted into a cylindrical hole in the polar region. The flared ends of the clip serve as a unidirectional gripping element that prevents the polar clip from backing out of the hole once

it is installed. The equatorial clips may be secured to body 12 using pockets or through-holes 30 created in regions 32 that exist for the purpose of providing the clips with a location to provide secure attachment. These equatorial clips 28, also made from metal wire can be attached by providing that the middle portion of the clip resides within the hole 30, and the end portions of the clip curve around the region 32, as illustrated, to fix them securely to the body 12 in the shape of a “D”. This D shape facilitates the differentiation of these marker elements from the polar clips and from conventional haemostatic clips that may be used to control bleeding during the surgical procedure. In an alternate method of securing the clips, as can be seen in Figure 7, the peripheral clips 28 may be placed in a lumen of a long spiral segment 12 of bioabsorbable tubing. The clips can be made from any biocompatible, radio-opaque material, such as titanium, stainless steel, gold or composite polymer materials (e.g., made with carbon or Barium Sulfate) having the desired visualization characteristics.

[00053] As noted above, the bioabsorbable body 12 itself may have visualization properties in addition to or in place of the clips 24, 26, 28. That is, the characteristics of the body material, or a coating on the body, may be chosen so that the body itself may be visualized on an imaging device and used for targeting. In particular, the body 12 may have radiodensity (or magnetic spin recovery when using MRI) that is different from the tissue surrounding the cavity into which the implant 10 is placed for the purpose of making the body 12 visible on an imaging device. For example, breast tissue can present values ranging from -140 to 50 on the Hounsfield scale – a linear transformation of the original linear attenuation coefficient measurement to one in which the radiodensity of distilled water at standard pressure and temperature (“STP”) is defined to have a Hounsfield number of zero, while the radiodensity of air at STP is defined to have a Hounsfield number of -1000. Details for creating this contrast in an implantable device can be found in published U.S. patent application no. 2011-0004094 A1, filed on May 28, 2010 and entitled Bioabsorbable Target for Diagnostic or Therapeutic Procedure, which is hereby incorporated by reference. The density of the body 12, however, should not be so high as to impart significant attenuation of the radiation beams or imaging artifact, which may result in clinically compromised target delineation or altering the dose delivered by a clinically significant amount. Where clips or other markers are used, the density of the body 12 may in some cases be indistinguishable from that of the surrounding tissue for visualization and treatment purposes. In addition, the

body 12 material and/or the clips may have a roughened or faceted surface finish to enhance the ultrasound imaging ability of the visualization device.

[00054] Various materials that could be used to construct body 12 include known bioabsorbable materials such as polyglycolic acid (PGA, e.g., Dexon, Davis & Geck); polyglactin material (VICRYL, Ethicon); poliglecaprone (MONOCRYL, Ethicon); and synthetic absorbable lactomer 9-1 (POLYSORB, United States Surgical Corporation) and polydioxanone. Other materials include moldable bioabsorbable materials such as poly lactic acid (PLA), including Poly L- lactic acid (PLLA) and various PLA/PGA blends. These blends can include caprolactone, DL lactide, L lactide, glycolide and various copolymers or blends thereof. Mixtures of any of the aforementioned materials can also be used, as required. The materials can be modified, by cross-linking, surface texturing, or blended with one another to control degradation rates over varying lengths of time, after which they are substantially or completely resorbed. Another manner in which degradation rates can be altered is by subjecting them to additional radiation in the dose ranges typically used for radiation sterilization. For example, subjecting the device to e-beam radiation in the dose range of 25 to 40 kiloGray (kGy) is typical for an adequate, validated sterilization cycle. However, subjecting the device to an additional 25 to 75 kGy can be useful to accelerate the in-situ degradation rate without significantly adversely affecting the functional short-term mechanical properties of the device. In embodiments that are used for radiation therapy targeting, the mechanical properties of body 12 are maintained for a long enough for treatment to take place. In some cases, the body 12 lasts long enough for tissue to infiltrate the cavity such that the position of the visualization markers is fixed within the tissue. Also, the material is preferably rigid enough for the overall effect of the spiral shape to behave in a resiliently deformable manner after implantation.

[00055] A cross sectional shape of the body 12 may also be selected to achieve the desired spring constant and absorbance parameters. In general, body 12 may have a cross section that is circular, oval, ovoid, cruciform, or rectangular. Other shapes can also be used.

[00056] As illustrated in Figures 2 and 3, the implant 10 may also have a strut 36 extending in the direction of its longitudinal axis 34. In particular, the strut 36 can be connected between the north and south polar extensions 20, 22. In a preferred embodiment, the strut 36 provides structural support, but also allows some translation of at least one polar

region toward or away from the other polar region with respect to an unflexed position of the spiral body 12. In many situations in use, the spiral body 12 will flex in the manner of a spring and particularly in compression. Strut 36 allows compression along the longitudinal axis, but may also provide a stop to prevent over compression of the spiral body 12.

[00057] In one embodiment, the strut 36 is a tubular element that fits over each of extensions 20, 22 and maintains a fixed relationship with one extension while sliding with respect to the other extension. This configuration would allow the spiral body 12 to be compressed until an edge of the tubular strut 36 contacted one of the polar regions 16, 18 which would act as a stop. In another embodiment, the strut 36 could slide with respect to each of the extensions 20, 22. In a still further embodiment, the strut 36 could comprise two overlapping tubes that slide with respect to each other in the longitudinal direction and opposed ends of such a strut could be fixed to the polar extensions 20, 22. In a non-sliding embodiment, the strut 36 could be fixed to both extensions 20, 22 with no internal sliding.

[00058] The present inventors have also developed a preferred fabrication method for forming the body 12. In a fabrication step, illustrated in Figures 4 and 5, body 12 is formed into two substantially planar, opposed, and connected spirals. Body 12 could be extruded and then heat-formed as shown in Figure 5 (the shaping of a thermoplastic material by heating it and causing a permanent deformation (such as bending) that remains after the material cools) into the desired shapes described above, however, such handling of bioabsorbable is difficult and repeatability in forming the shapes can be challenging. In a preferred embodiment, this first step is carried out by injection molding as shown in the spiral forms of Figure 4AB and C. This shape can be molded from a simple two part mold without the need for side pulls, which allows for repeatability yet modest tooling costs. In addition, the molded part allows for more surface detail, for example at the two ends of the part – rounded ends with pockets for visualization markers or fabrication fixtures may be incorporated into the design, as illustrated for example in Figure 4A. Pockets for additional visualization markers can be molded along the length of the body at appropriate intervals, as shown in Figure 4B.

[00059] The entire body 12 may at this stage be substantially planar to facilitate injection molding. When we say substantially planar we mean of a configuration that is able to be injection molded without the need for side pulls, or that can be die cut from a sheet form of the body material. Visualization markers may also be attached to body 12 at this stage

where the body is substantially planar, as shown in Figure 4C, which is conducive to automated assembly methods.

[00060] In the embodiment of Figure 4, left spiral 40 includes a north polar extension 42, while opposed right spiral 44 includes a south polar extension 46. A connecting segment 48 connects the two opposed spirals.

[00061] Figure 5 illustrates a similar embodiment to Figure 4, but lacking polar extensions, which could be heat-formed later, or omitted completely – especially if a central strut is not desired. A subsequent step in a fabrication process results in a device that is illustrated in Figure 6, where the configuration of Figure 5 has been heat-formed so that one spiral 40 is located above the other spiral 44 so that the spirals share a common longitudinal or central axis. For the embodiment of Figure 5, either spiral could go over the other. For the embodiment of Figure 4, however, having polar extensions 42, 46 that have a directional element, the left spiral 40 preferably would be placed on top of the right spiral 44 so that the polar extensions extend toward each other – that is, toward the center of the finished spiral implant.

[00062] During the heat-forming process the centers of the overlapping spirals 40, 44 can be reformed, (e.g., over a mandrel) so that body 12 takes the general shape of a sphere. The final shape of the final implant can be determined during this heat forming step. For example, heat forming the centers to project out of plane less than the full radius distance of a sphere shape will result in a flattened sphere. Heat forming beyond the full radius distance will elongate the sphere to a football shape as shown in Figure 1B. Forming one spiral side farther from the midline than the other will result in an egg shape. In embodiments in which the central strut is desired, the strut may next be added. To facilitate even and repeatable reforming, the body 12 may be placed around a spheroid forming mandrel and heated to form the final desired shape. To enhance fabrication consistency, the forming mandrel may have channels along its surface to hold the part in a given position during the heat-forming process.

[00063] Figure 7 shows a device formed as shown in Figure 6, with the addition of marker clips which are placed at desired locations along the central lumen of the body of the device. These marker clips may be placed in the lumen before or after final heat forming into the final spheroid spiral shape.

[00064] Figures 8 through 10 all describe alternate embodiments where the bioabsorbable marker component (e.g. body 12) is initially formed in a relatively planar configuration (e.g. for ease of injection molding) and then the component is subsequently heat-formed into its final spheroid or other three dimensional configuration. Note that the embodiments have an open architecture to maximize the opportunity for tissue ingrowth, tissue movement, tissue approximation and/or fluid communication across the peripheral boundary of the marker device. The open architecture also allows for the passage of suture around a portion of the device by the clinician to help secure the device to adjacent tissue (e.g., chest wall) to further immobilize the device. The marker devices described herein comprise a resilient framework of bioabsorbable elements with locations for periodic secure attachment of radiodense marker elements (e.g., titanium wire) along the periphery of the device. The flexibility and conformability of the device allows for device deformation for increased comfort and conformance to the surrounding tissue in which the device is placed. When we use the term “peripheral boundary” of the marker device, we are referring not only to the boundary edge of the marker device itself but also to the “empty space” regions in between the portions of the marker device that are generally consistent with the perimeter of the device.

[00065] Figure 8A shows an alternate embodiment of the device 10a where the bioabsorbable component is molded in a planar, cross-like configuration with a body having four branches, 12a, 12b, 12c, and 12d. Each branch includes a feature 30a for attaching a marker about an equator of the device, while one branch 12a includes at its end a feature 30a for attaching a north pole marker and the center of the cross includes a feature 30a for attaching a south pole marker. Figure 8B shows the device after the component has been heat formed (e.g., around a spherical mandrel with recessed grooves) to generate a spherical device 10a having north and south polar regions 16, 18. Other shapes described herein could also be formed in this manner, as well as, shapes formed with more or fewer branches. In general, the number of branches will be based upon the width of the branches, the desired size of gaps between the branches in the finished device (and thus the device’s “openness”), and the number of markers desired about the equator of the device.

[00066] Another embodiment of the device is shown in Figures 9A through 9D. A first portion 52 of a bioabsorbable component 10b is molded in the form as shown in Figure 9A having three petal-like branches 12e, 12f, and 12g. The three cylindrical protrusions 54 in

the center of each petal-like element contain a radiopaque marker (not shown) such as a titanium wireform for use as equatorial markers. The central cylindrical protrusion 56 comprises a fastening means (e.g., press-fit or mating threads) for assembling the device and can also include a radiopaque marker (not shown). The component 52 can subsequently be heat-formed around a curved mandrel to create a component as illustrated in Figure 9B. A central axial extension 58 can be added to two portions 52 to create an assembled bioabsorbable device 10b as shown as Figure 9C, which is the exploded view of the completed device that is shown in Figure 9D.

[00067] Figures 10A to 10D show yet another embodiment of the device 10c where the bioabsorbable component is molded in an alternating continuous filament 12h configuration forming four loops 62a-62d in the form of a cross with each loop being open towards the center. Each loop 62a-62d includes a feature 30 to allow placement of equatorial markers 28. Loop 62a includes a feature 64 for placement of a north polar marker 24, while a feature 66 for placement of a south polar marker 26 is located at the center of the device 10c between any two loops. Figure 10B shows the device 10c after the component has been heat formed (e.g., around a spherical mandrel with recessed grooves) and with the markers 24, 26, 28 added. The forming mandrel not only creates a spherical shape of the final configuration but the recessed grooves in the mandrel also help space apart the filaments to create a relatively even spacing of the bioabsorbable filament (and thus equal spacing of gaps or openings to allow tissue infiltration) along and throughout the spherical surface of the device. Figure 10C and Figure 10D show top and side views, respectively of the device 10c embodiment shown in Figure 10B.

[00068] These types of devices can typically be used by surgeons who do not actively reapproximate the tissue (e.g. lumpectomy) cavity that they have created, as has been previously described herein. In addition, this device can also be used by surgeons who choose to surgically reapproximate at least a portion of the breast tissue surrounding the lumpectomy cavity. This reapproximation, sometimes called cavity closure, is typically accomplished (e.g. in the growing field of oncoplastic surgery) by suturing the breast tissue on either side of the lumpectomy cavity and drawing the tissue together (See Figure 11) prior to skin closure. Figure 11 shows a spiral marker 10 as described in Figure 1 that has been placed in a lumpectomy cavity 72 of a patient's breast. As can be seen in the figure, the cavity is in the process of being closed with suture 74 and one can appreciate the tissue

infiltrating 76 into the interstices of the spiral device 10. The open architecture of the device allows the tissue to flow or otherwise move within the peripheral boundary of the device as the tissue is pulled together and secured by suture. This device thus allows the surgical cavity site (and its margins) to be marked in a 3 dimensional fashion for subsequent imaging even though the lumpectomy cavity itself may be surgically altered or naturally altered in original size and/or shape. The lumpectomy cavity may be naturally (i.e. passively) altered in size or shape by partially or totally collapsing on itself or some cases by expanding due to seroma buildup within the lumpectomy cavity in the post-surgical period.

[00069] Figure 12 shows a similar device 10 in another lumpectomy cavity 72 and one can appreciate the degree to which the surrounding tissue has infiltrated 76 within and flowed around the marker 28. Thus, these open architecture 3- dimensional tissue markers as described herein, allow the clinician to demarcate the closed and/or collapsed cavity with a level of 3-dimensional accuracy that has not previously been possible.

[00070] Figure 13 shows device 10 after placement in a lumpectomy cavity 131 at the time of surgery via a standard surgical incision 132. Because of the open architecture of the device 10, the breast and fatty tissues 133 at the margin of the lumpectomy cavity are able to naturally infiltrate across the peripheral boundary (dotted line 134) of the tissue marker device. The peripheral boundary 134 of the device is defined as the continuous overall surface shape that is defined by the outer regions or peripheral surface elements (for example 135) of the device. For the device 10 shown in Figure 13, the peripheral boundary is an ovoid surface, a view of which is shown in this figure as an oval dotted line 134. Cavity boundary tissue can be seen to insinuate, penetrate, and/or flow between and around the elements of the device, thereby crossing the peripheral boundary of the device at for example, tissue locations 136 and 137.

[00071] The method of use for example, in a breast lumpectomy procedure is as follows: a lumpectomy cavity is created by surgically removing breast tissue via a skin incision (which may be minimally invasive, e.g. via tunneling from the areola), the cavity is sized using a sizer or other sizing method (e.g. direct examination of the lumpectomy specimen or cavity), the appropriately sized 3 dimensional open architecture bioabsorbable tissue marker is placed directly into the lumpectomy cavity via the surgical incision causing the breast tissue at the margin of the cavity to actively (e.g. via suture closure) or passively

insinuate or otherwise move across the peripheral boundary of the tissue marker device, and then the wound or skin is closed in standard surgical fashion.

[00072] In yet another alternative method of use, the device is used as above but with the added step of passing some suture around one or more portions of the device and then passing the suture through adjacent tissue to tether or otherwise further secure the device to the adjacent tissue.

[00073] In some instances, the degree of tissue insinuation within the boundaries of the marker device (and hence the cavity) can be fairly limited. This instance can be appreciated in Figure 14, where a marker device 10 of the type described in Figure 1 has been placed in a lumpectomy cavity 72 of a patient's breast. One can see that in this approach, only a modest amount of tissue has infiltrated between the spiral elements and a significant portion of the original cavity remains free of tissue, with the marker device (including the marker clips) delineating the margins of the lumpectomy cavity.

[00074] Figure 15 shows an alternate embodiment 10d where a mesh-like structure comprised of biodegradable filaments 82 is formed into a cavity-sized open-architecture shell-like structure with marker clips 84 secured at various peripheral locations of the structure. In one embodiment, the marker clips are still placed at the north and south poles and with four markers placed around the equator. This construction maximizes the overall diameter of the device while using a minimum mass of biodegradable material. The mesh-like structure (woven or braided filaments, or die-cut sheet) is also conformable yet still maintains a 3-dimensional volumetric characterization of the adjacent tissue as it resides within the cavity. The marker clips reside at the periphery of the device and hence optimizes visualization of the boundaries of the surgical cavity. The degree of tissue infiltration across the boundary of the device perimeter can be varied by the chosen gap size (e.g., from 1mm to 10mm). All versions within this gap size range are of an open-architecture design where fluids (e.g. blood, seroma, lymphatic fluid) can freely pass across the peripheral boundary of the device after implantation.

[00075] A method according to the invention for treating these and other malignancies begins by surgical resection of a tumor site to remove at least a portion of the cancerous tumor and create a resection cavity as illustrated in Figure 18. As illustrated, an entry site or incision 102 is created in patient 100 in order to remove tissue and create a cavity 104.

Although Figure 7 visually represents the surgical resection cavity in concept, it is important to note that most cavities are not that simplistically configured in the 2-8 week postoperative period that they are most likely to be visualized in the clinical imaging environment. For example, Landis et al (“Variability among breast radiation oncologists in delineation of the postsurgical lumpectomy cavity,” 67(5) Int J Radiat Oncol Biol Phys 1299-308 (2007)) have documented the difficulty in delineating the cavity boundaries to be targeted in the postoperative period. Landis et al also document the range of sizes and shapes and geometric uncertainties that can be typically seen in the clinical environment. Tissue margins can be difficult to delineate due to uncertainty about the extent and position of the excision cavity and its adjacent tissue. Therefore, a device of the present invention that is placed into the surgical cavity at the time of cavity resection will demarcate these tissue boundaries at the time the cavity is surgically created, so that postoperatively (e.g. during the imaging required for subsequent radiation therapy) the tissue boundaries are much easier to identify (or identified with higher confidence as to their configuration and specific location). In some clinical environments, only the marker clips of the device will be visible and in other cases, the bioabsorbable carrier material may also be visible in addition to the marker clips. In either case, a more accurate delineation of the tissue adjacent to the lumpectomy cavity can be documented than would be possible had the marker device of the present invention not been placed, or had individual discrete marking devices (e.g. clips) been placed into the cavity as an alternative.

[00076] Following tumor resection, an implant of the invention (using any of the embodiments described herein) is placed into the tumor resection cavity 104. Placement can occur prior to closing the surgical site 102 such that the surgeon intra-operatively places the device, or alternatively, a device can be inserted after the initial surgical resection (e.g., during a re-excision to remove more tissue due to positive or inadequate surgical margins). In some cases, a new incision for introduction of the device may be created. In either case, the device, whose peripheral surface is preferably sized and configured to reproducibly demarcate the tissue surrounding the resection cavity 104, is placed within the resected tissue cavity.

[00077] In some cases, it may be useful to employ a sizing tool in order to help the clinician choose the proper size and shape of device to be implanted for a given surgical cavity. It is particularly useful for the sizing tool to represent not only a similar general size

(e.g. width and length) of the device to be implanted, but also to represent the general device configuration and/or device flexibility as well. With these attributes in mind, a sizing tool 92 is shown in Figures 16A and 16B. The exemplary sizing tool 92 includes a handle portion 94 and a sizing portion 96 that represents the size of a particular size of implantable device. Alongside the sizing tool 92 in the figure is an implantable device 10 that is represented by the sizing tool. Figure 16C shows an array of such sizing tools 92 with their correspondingly sized and shaped implantable marker devices 10. In use, prior to selecting the specific size and shape of marker to implant, the clinician chooses a particular sizing tool from a set of reusable sterile sizing tools, such as that shown in Figure 16C. While holding the handle of the sizing tool, the clinician places the spheroid end of the sizing tool into the surgical cavity. If desired, the tissue surrounding the tool may be surgically approximated by one or more temporary stitches or staples, to give the clinician a sense of how the tissue interacts with the sizing tool and hence how the tissue will interact around the implantable marker device. If the particular size or shape of the sizing tool is not optimal for the desired characteristics (e.g. wound tension, tissue cavity conformance), an alternately sized or shaped sizing tool may be used until the desired interaction with the surrounding tissue is achieved. Subsequently, the sizing tool is removed from the wound and the clinician selects the implant device that most closely matches the sizing tool configuration, and then places the implant device in the tissue cavity. Subsequently the breast tissue interacts with the implant in a fashion predicted by the sizer tool and the clinician closes the skin incision.

[00078] Following insertion of the implant device, such as by an open method or using a mini-open (e.g. tunneling) approach, the implant occupies (at least a portion of) the tissue cavity 104 and demarcates the surrounding target tissue until such time as the implant resorbs. When the implantable device is implanted in a resection cavity in soft tissue, a substantial portion of the device can conform to the walls of the resection cavity. “Substantial portion” is used herein in this context to mean greater than or equal to about 25% of the outward facing surface of the implant is in direct apposition to the surrounding tissue. Given the irregularities of many lumpectomy cavity shapes, not all of the surface of the implant may be in direct apposition to the surrounding tissue. Depending upon a variety of factors such as anatomy and surgical technique, there may often be voids filled by air or seroma. In some embodiments and clinical cases, the implant fully conforms to the surrounding tissue – where fully conforms means greater than or equal to about 95% of the

implant's surface will be in direct apposition to surrounding tissue. Regardless of the percent of the device outer surface that comes in contact with the surrounding tissue, because of the open architecture of the device, there typically remains a portion of the resection cavity inner surface that does not come into contact with the implanted device. Otherwise the devices would not be of the open-architecture design, where there is free communication of fluids and tissue across the peripheral boundary of the device after implantation.

[00079] With the use of our invention, a defined tissue region is provided so that radiation can more accurately be delivered to the previously irregular or indeterminate tissue cavity walls. This defined surface can be delineated via a variety of imaging modalities such as ultrasound, MRI and CT or other x-ray by the bioabsorbable portion of the device or by the marker clips, or by both. In addition, the device may help reduce error in the treatment procedure introduced by tissue movement. The positioning and stabilization provided by the implant device may greatly improve the effectiveness of radiation therapy by facilitating radiation dosing and improving its accuracy. The result is a treatment method which concentrates radiation on target tissue and helps to minimize damage and preserve the surrounding healthy tissue. When the radiation dose is more precisely delivered, lower dose can be delivered to adjacent normal tissue, which improves the suitability for accelerated radiation treatment regimens (e.g., fewer dose fractions at a higher dose rate).

[00080] Prior to delivering radiation, but after placing the implant device, the device and the surrounding target tissue can preferably be visualized with an imaging device, including by way of non-limiting example, x-ray (kV or MV), conventional (2-D) mammography, 3-D mammography (including mammographic tomosynthesis, e.g., SELENIA Tomosynthesis by Hologic, Inc.), ultrasound, MRI, CT scan, PET, SPECT, and combinations thereof. These imaging devices provide a picture of the implant device and the surrounding target tissue to assist with the planning of external radiation therapy. Thus, the device can delineate the cavity boundaries so that a target volume may be derived. The device then provides a target for more accurate repositioning of the patient's targeted tissue immediately prior to each fraction of treatment. Finally, it can provide a means of real-time tracking the motion of the target volume so that the beams can either move with the target, can reshape dynamically to conform to a moving target or can be turned on and off as the target moves out of and back into the beams' path.

[00081] In the case of external beam radiation therapies such as three-dimensional conformal radiation therapy (3DCRT) and IMRT, the imaging procedures provide a map of the residual tissue margin and assist with targeting tissue for radiation dosing. The radiation beams are then adapted for delivering a very precise radiation dose to the target tissue. Also, the improved targeting capability reduces the patient setup errors (target positioning relative to the treatment beam). Both factors improve target tissue conformality, reduce the radiation exposure to normal tissues surrounding the targeted volume of the body, and can allow for smaller target volumes than would otherwise be prescribed due to the decrease in uncertainty of the tissue margins of the cavity.

[00082] Some treatment regimens require repeated radiation dosing over a course of days or weeks, and the device can be used in those cases to repeatedly position the tissue surrounding the resected tumor cavity. These steps can be repeated as necessary over the course of a treatment regimen. Preferably, the implanted device remains in place without intervention, i.e., without removal or actions to change its configuration, throughout the course of treatment.

[00083] While the specific examples provided relate to treatment of cancer in the breast, the devices and procedures described herein may be used for other anatomic sites as well, (e.g. muscle for sarcoma, liver for liver tumors) including any regions where tissue is removed and the patient may require targeted radiation treatment at or near the site of tissue removal. The device may also be placed in the cavity created by the open surgical biopsy of high risk non-cancerous or ultimately benign breast lesions as well as other non-cancerous tissue sites. Doing so identifies the cavity for future breast imaging studies, which can be useful for long-term patient monitoring.

[00084] In addition to the 3-dimensional structures that have been described, there is also a clinical need to provide relatively 2-dimensional versions of the device as well. Whereas the 3-D devices demarcate the boundaries of more 3 dimensional structure (e.g., lumpectomy cavity) these 2-D devices may be more useful to demarcate the more planar or curvilinear boundaries of tissue that may arise from surgical excision (e.g., during breast reduction).

[00085] Such planar yet compliant and conformable versions are shown in Figures 4, 5, and 17. These designs are useful for identifying the tissue boundaries that ultimately are re-

approximated, actively or passively, during various surgical procedures. The surgical procedures that may benefit from these 2-dimensional designs are procedures that require excision of soft tissue followed by reapproximation of the resection boundaries (e.g., as in breast reduction or lung-wedge resections).

[00086] Figures 4 and 5 illustrate a spiral planar form of a 2-D style marker that can be placed surgically into a region of tissue that can be surgically approximated. The spiral elements are free to flex to conform to the tissue planes as the tissue is surgically approximated.

[00087] Figure 17A illustrates another embodiment 10e comprising an array of flexible spines 112 made of a bioabsorbable polymer emanating from a central region 114. A radiopaque marker 28 of the type described previously resides at the extremity of each of the spines. A marker clip may reside at the central region as well (not shown). In use, the device is placed at the time of surgery along the surface of the region of tissue to be approximated. In many cases the tissue surfaces can be irregular in surface shape (e.g., non-planar) and so as the tissue surfaces may be approximated (e.g., by surgical suturing) yet the device is still able to flex and conform to the irregular surface shapes of the tissue surfaces. Again the open architecture of this structure allows for unencumbered fluid passage and tissue mobility while still demarcating the excised issue boundaries.

[00088] Figure 17B illustrates yet another embodiment 10f similar to the device described with respect to Figure 17A except that the central region 116 is a linear spine like element, which is also made of bioabsorbable material. Marker elements reside not only on the peripheral spines but also at periodic intervals along the central spine of the device. In use the device may be cut at various locations along the spine to best fit the anatomical site it is to be placed, prior to placement at the tissue site.

[00089] Figure 18 illustrates yet another embodiment 10g where the device is comprised of a flexible bioabsorbable mesh or screen 118 that contain marker 28 elements that reside fixedly to the periphery or other locations along the flexible plane. In this embodiment radiopaque markers are comprised of Titanium wire elements that envelop the filaments of the mesh or screen material. In other embodiments (not shown), the wire elements may be enveloped within the bioabsorbable material and oriented either parallel or perpendicular to the generally planar flexible surface of the embodiment (as shown in Figure

4B). One advantage of the perpendicular marker elements is that the marker elements may partially embed (like cleats of a shoe sole) into the adjacent tissue to secure the position of the device along the surface of the tissue to be approximated.

[00090] A person of ordinary skill in the art will appreciate further features and advantages of the invention based on the above-described embodiments. Accordingly, the invention is not to be limited by what has been particularly shown and described, except as indicated by the appended claims or those ultimately provided. All publications and references cited herein are expressly incorporated herein by reference in their entirety, and the invention expressly includes all combinations and sub-combinations of features included above and in the incorporated references.

CLAIMS

1. An implantable fiducial tissue marker device to be placed in a soft tissue site through an open surgical incision, comprising:
 - a bioabsorbable body formed whose outer regions define a peripheral boundary of the marker device
 - a plurality of visualization markers secured to the body so that visualization of the marker device using medical imaging equipment will indicate the location, of the tissue site;
 - wherein the implantable marker device is conformable to the adjacent soft tissue and whose peripheral boundary is able to be penetrated by adjacent soft tissue during its use.
2. The device of claim 1, wherein the bioabsorbable body is in the shape of a spiral, the spiral having a longitudinal axis, and turns of the spiral being spaced apart from each other in a direction along the longitudinal axis.
3. The device of claim 3, wherein the peripheral boundary of the device has a shape selected from the group consisting of spherical, scalene ellipsoid, prolate spheroid, and oblate spheroid shape.
4. The device of claim 3, wherein the device has a north polar region and a south polar region at opposed ends of the longitudinal axis.
5. The device of claim 4, wherein a strut is connected between the north polar region and the south polar region.
6. The device of claim 5, wherein the strut includes a sliding element to allow the spiral body to be compressed in the manner of a spring.
7. The device of claim 4, wherein visualization markers are attached to the body in the north polar region and/or the south polar region.
8. The device of claim 7, wherein a plurality of visualization markers are attached to the body about an equatorial region of the substantially spheroid device.
9. The device of claim 8, wherein at least four visualization markers are attached to the body about its equatorial region.

10. The device of claim 9, wherein at least some of the visualization markers are radio-opaque clips.
11. The device of claim 10, wherein the radio-opaque clips are attached to the body using preformed holes in the body into which the clips can be pressed and attached.
12. A method for fabrication of a tissue marker device, comprising:
 - using injection molding to form a body made of a bioabsorbable polymer in a planar configuration
 - heat forming the body so that the body is reconfigured from a planar configuration to a three dimensional configuration.
13. The method of claim 12, further comprising forming pockets or through-holes in the body during injection molding and attaching visualization markers to the pockets or through-holes.
14. The method of claim 12, wherein the injection molded body includes north and south polar regions, with each polar region including a polar extension that is directed toward an interior of the device.
15. The method of claim 14, further comprising connecting a strut to the polar extensions.
16. The method of claim 15, wherein the strut is slideably connected to at least one of the polar extensions.
17. The method of claim 12 whereby two or more separate parts are connected to achieve a finished product.
18. An implantable tissue marker device to be placed in a soft tissue site through a surgical incision, comprising:
 - a bioabsorbable body form of a spiral and defining a spheroid shape for the device, the spiral having a longitudinal axis, and turns of the spiral being spaced apart from each other in a direction along the longitudinal axis;
 - a plurality of markers disposed on the body, the markers being visualizable by a radiographic imaging device;

wherein the turns of the spiral are sufficiently spaced apart to form gaps that allow soft tissue to infiltrate between the turns and to allow flexibility in the device along the longitudinal axis in the manner of a spring.

19. The device of claim 18, wherein the device has a spring constant in the direction of the longitudinal axis between about 5 and 50 grams per millimeter.

20. The device of claim 18, wherein the bioabsorbable body includes opposed polar regions along the longitudinal axis.

21. The device of claim 20, wherein markers are placed in each of the opposed polar regions.

22. The device of claim 21, further including a plurality of markers placed along an equatorial region of the body.

23. The device of claim 22, wherein at least four markers are placed along the equatorial region.

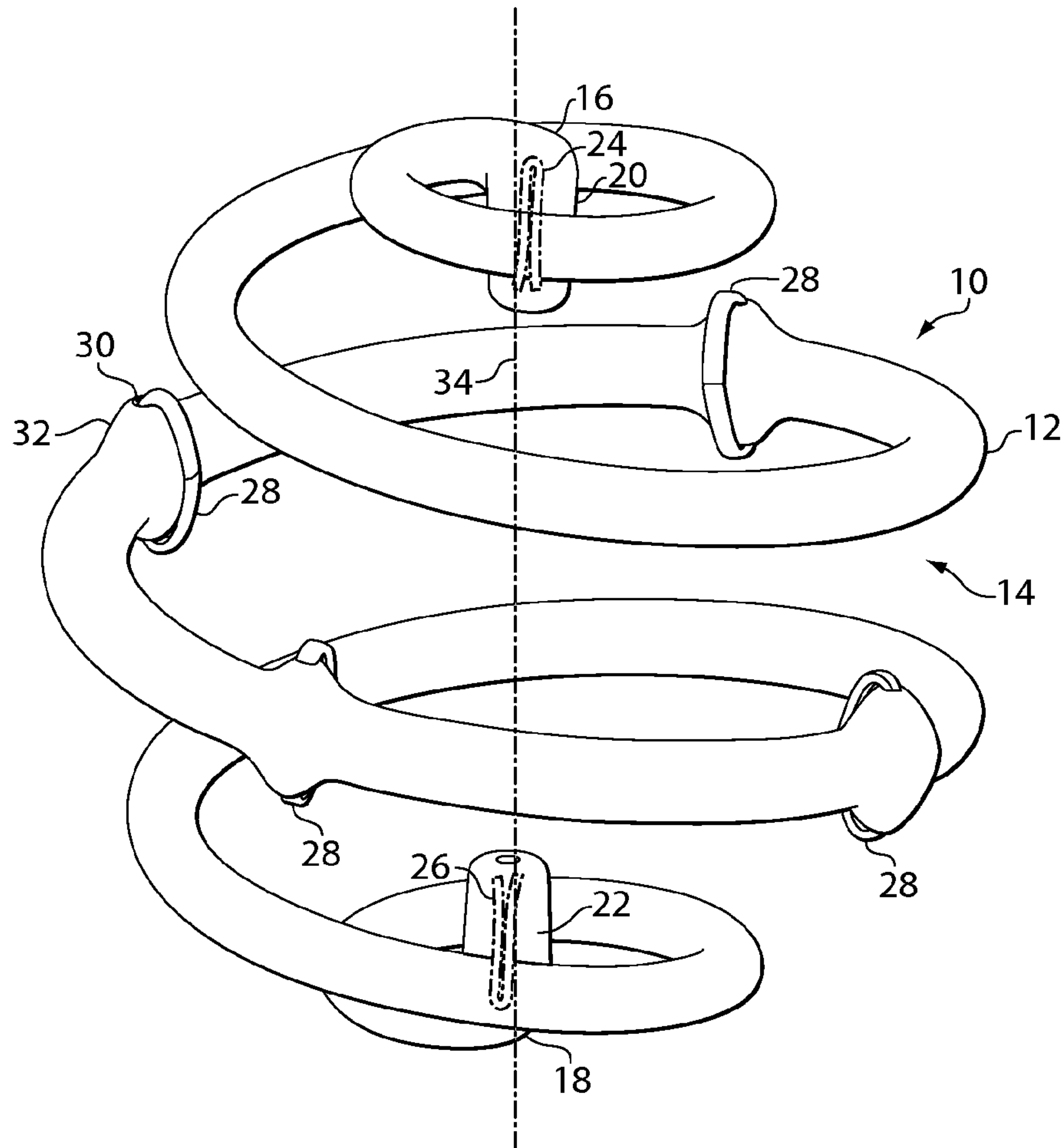

Fig. 1A

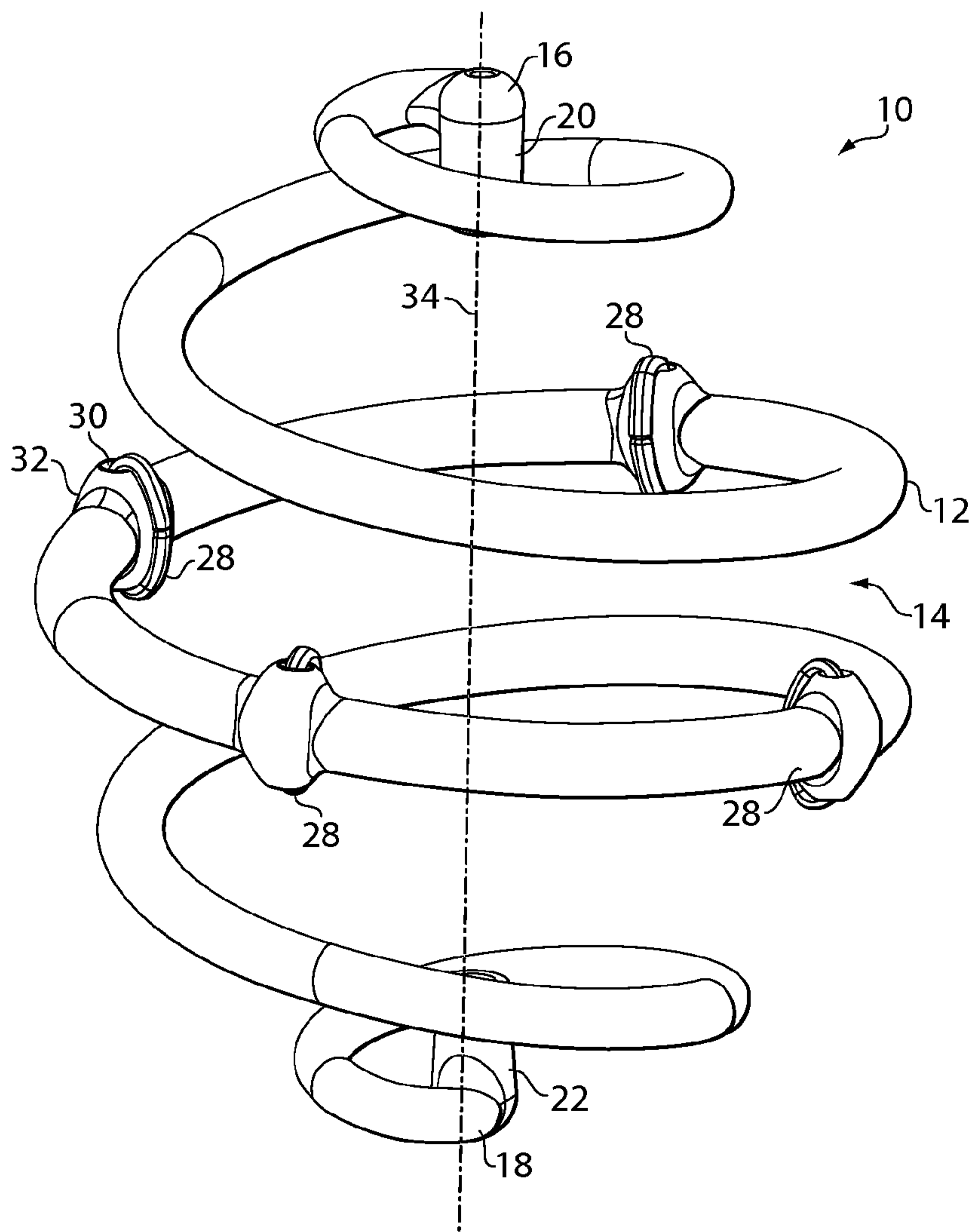

Fig. 1B

3/22

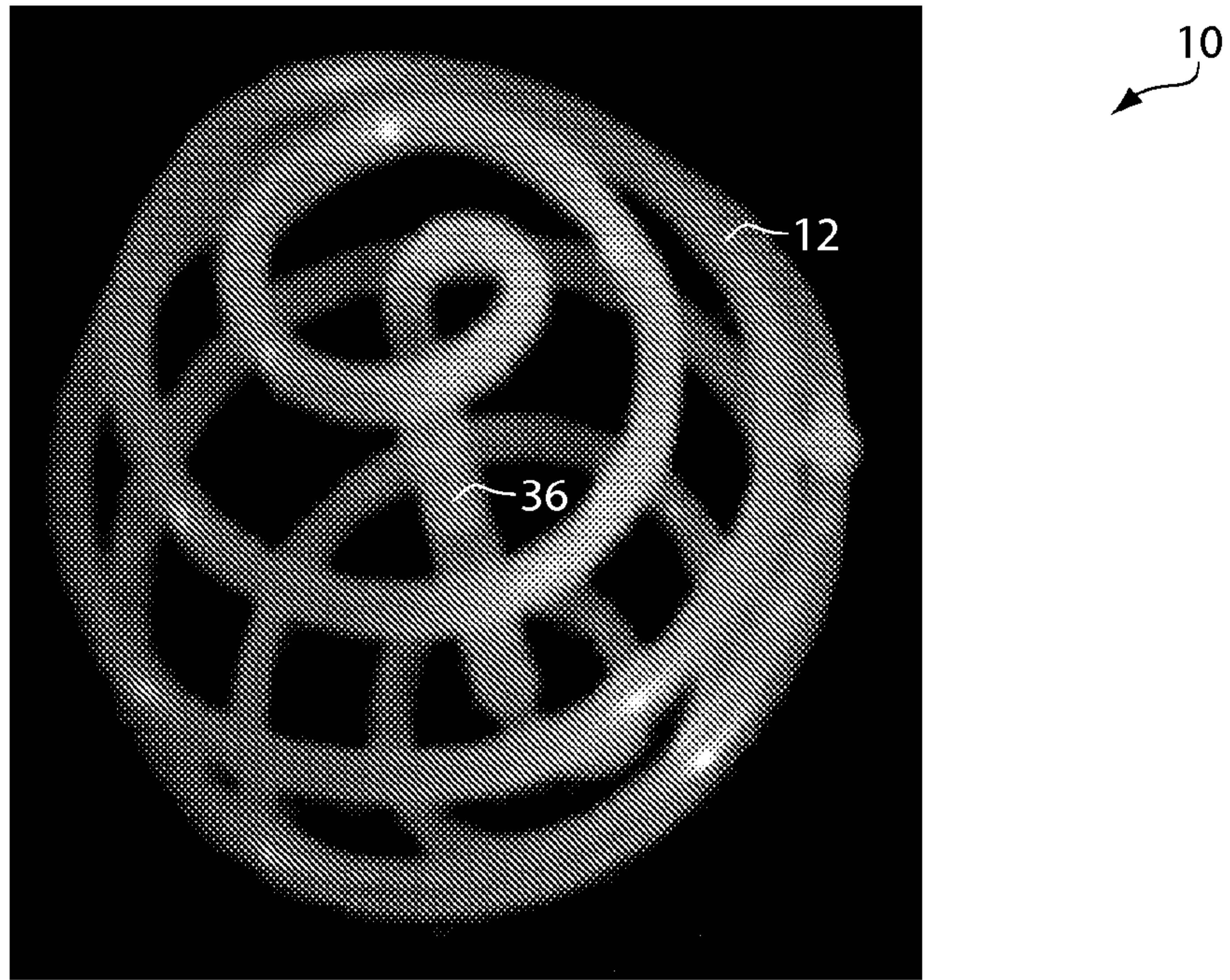

Fig. 2

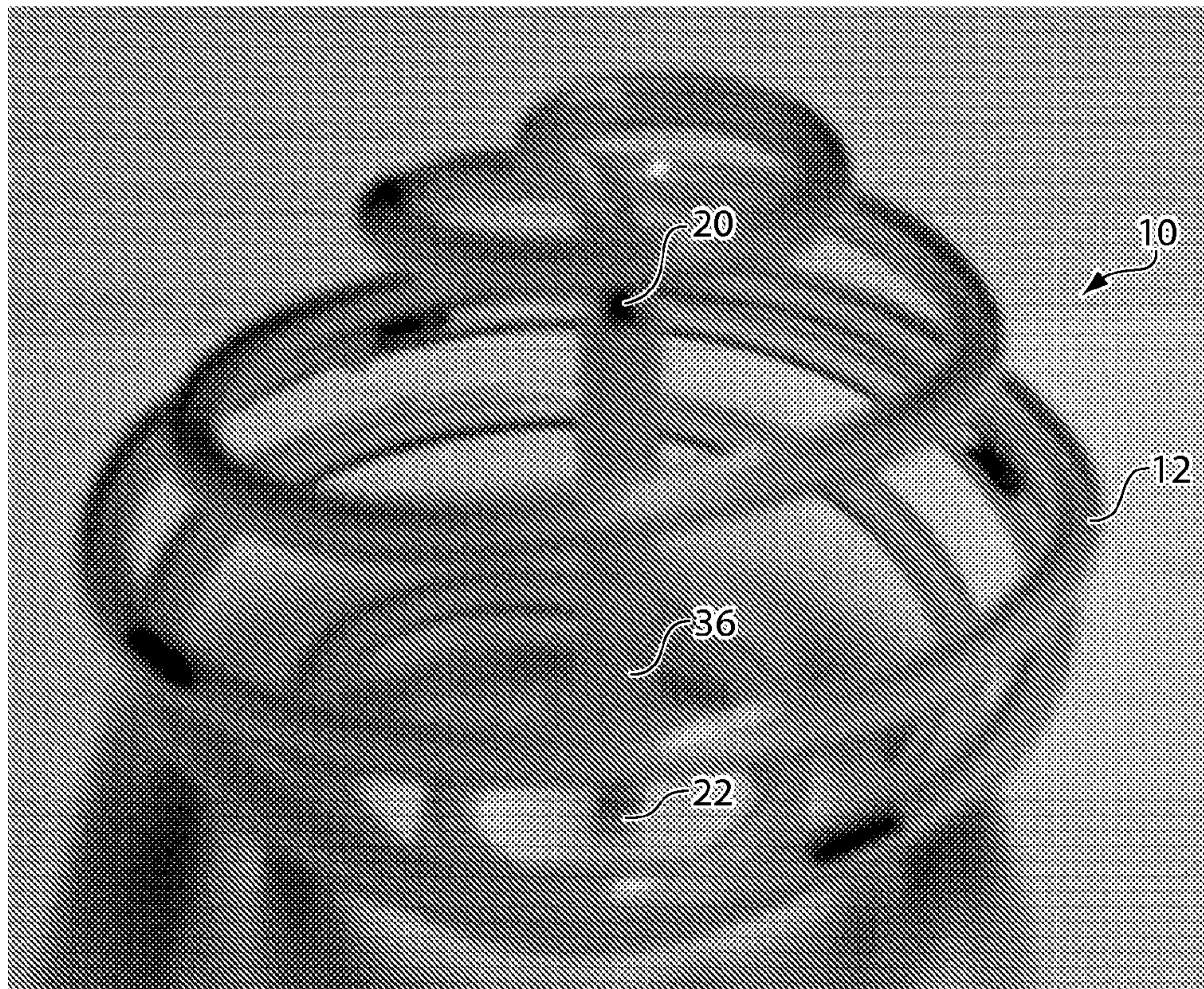

Fig. 3

4/22

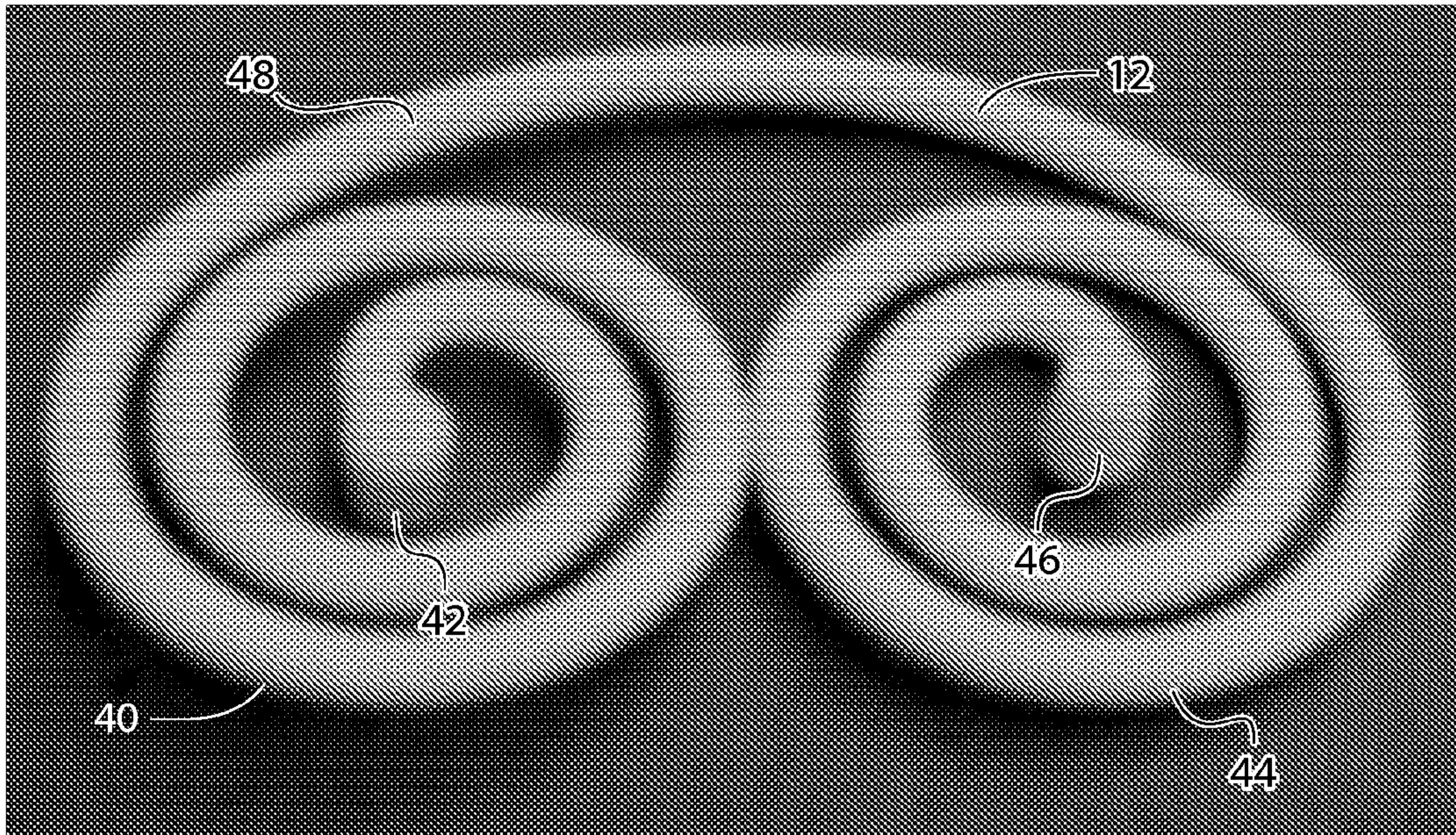

Fig. 4A

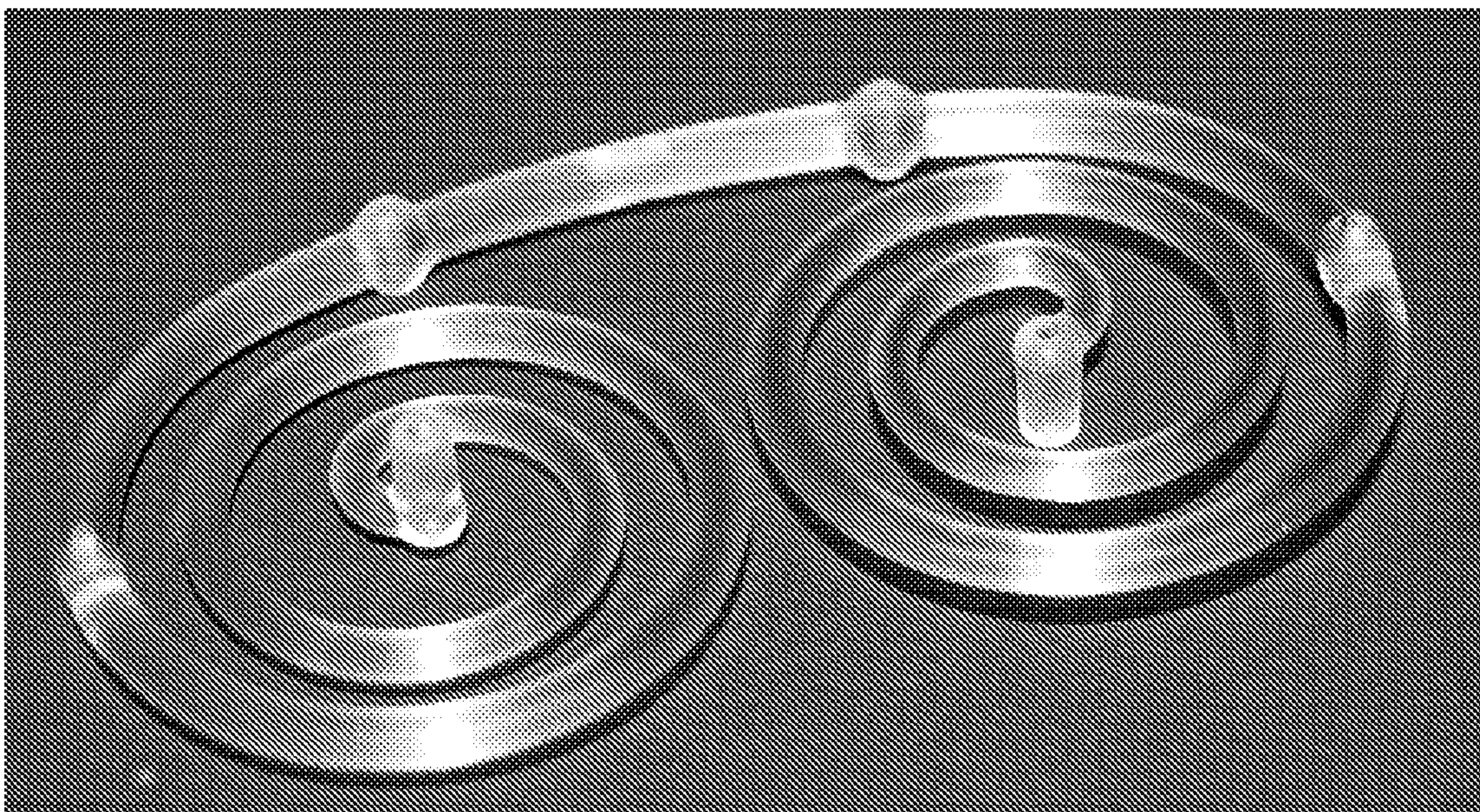

Fig. 4B

5/22

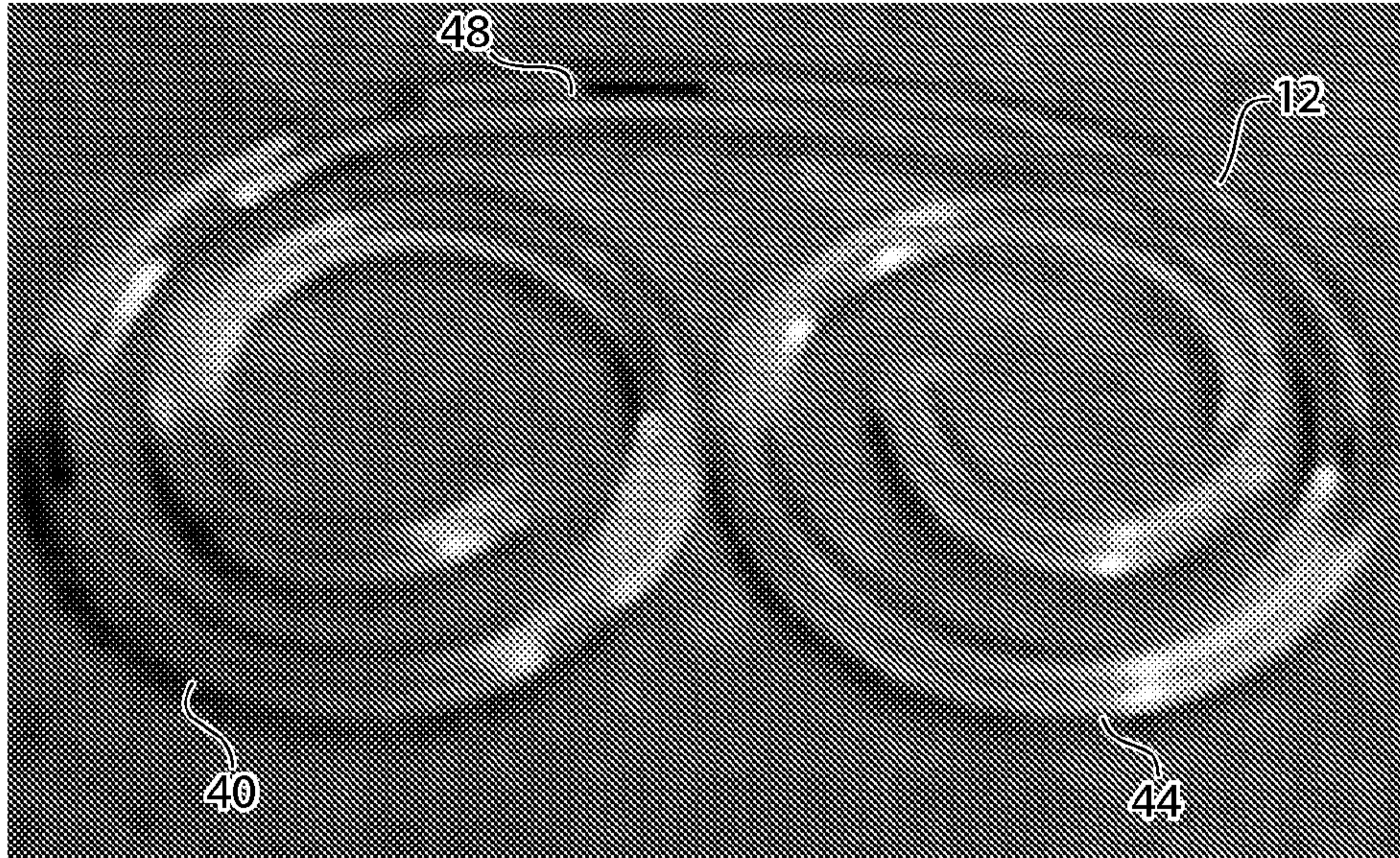

Fig. 5

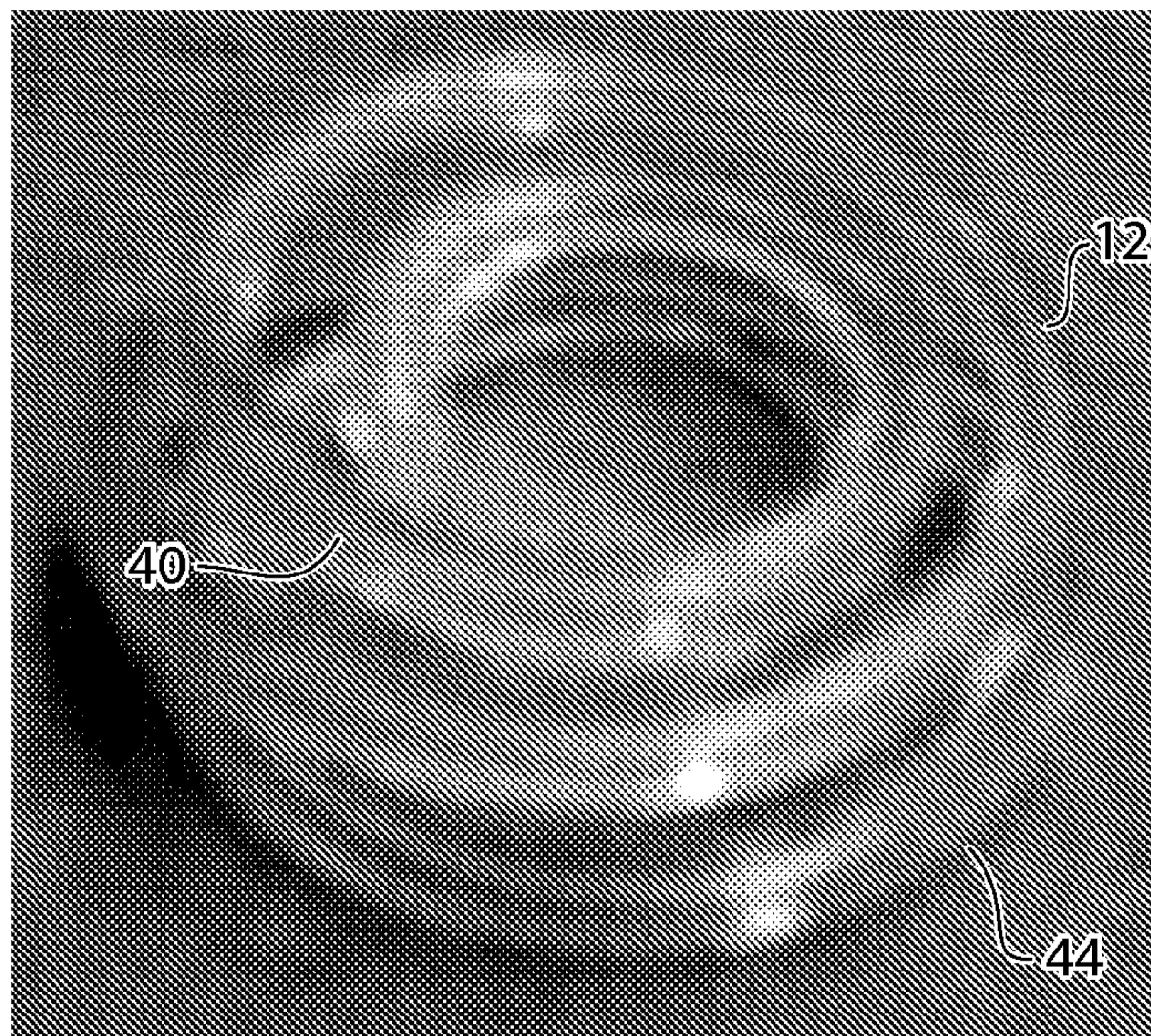

Fig. 6

6/22

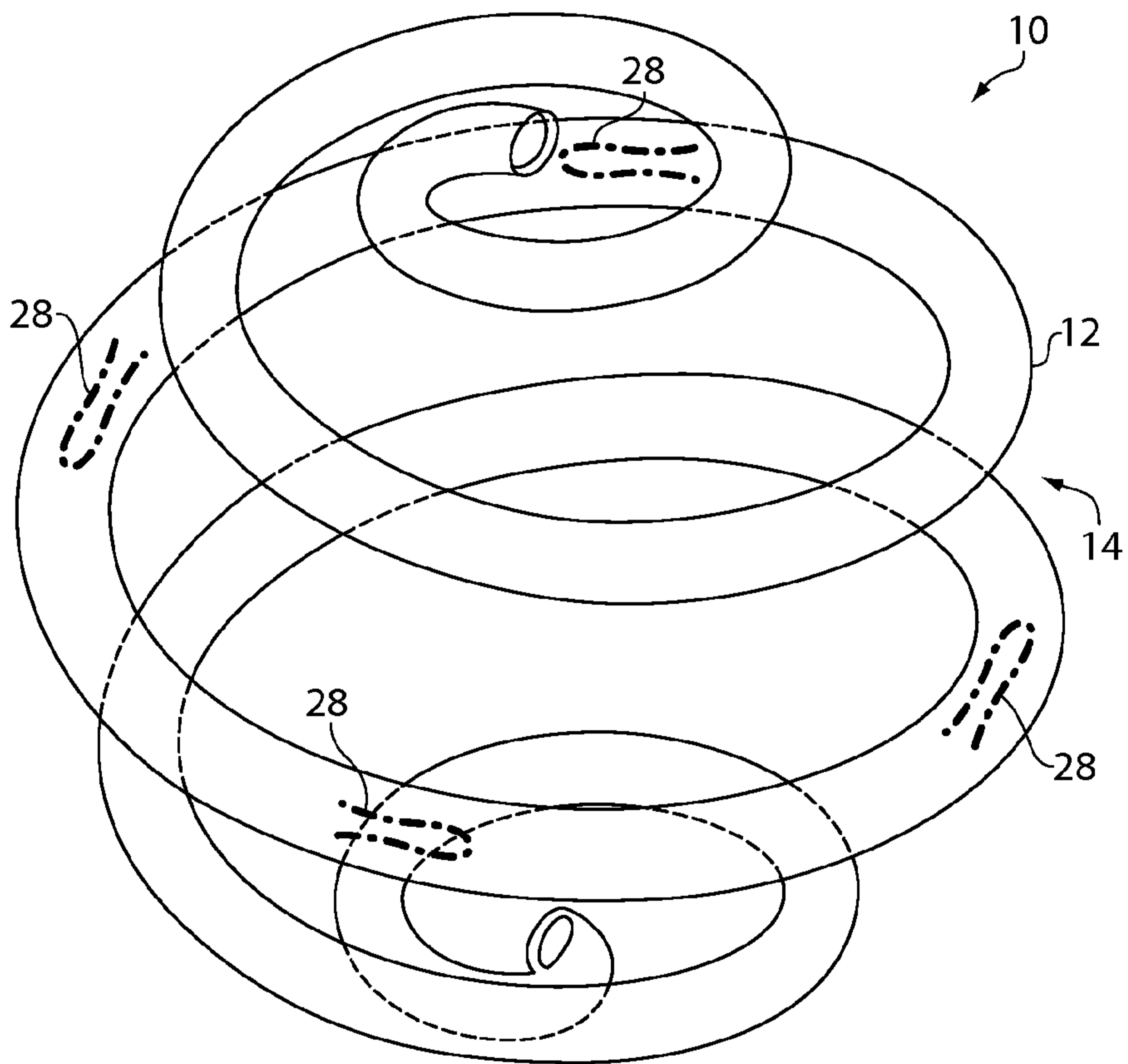

Fig. 7

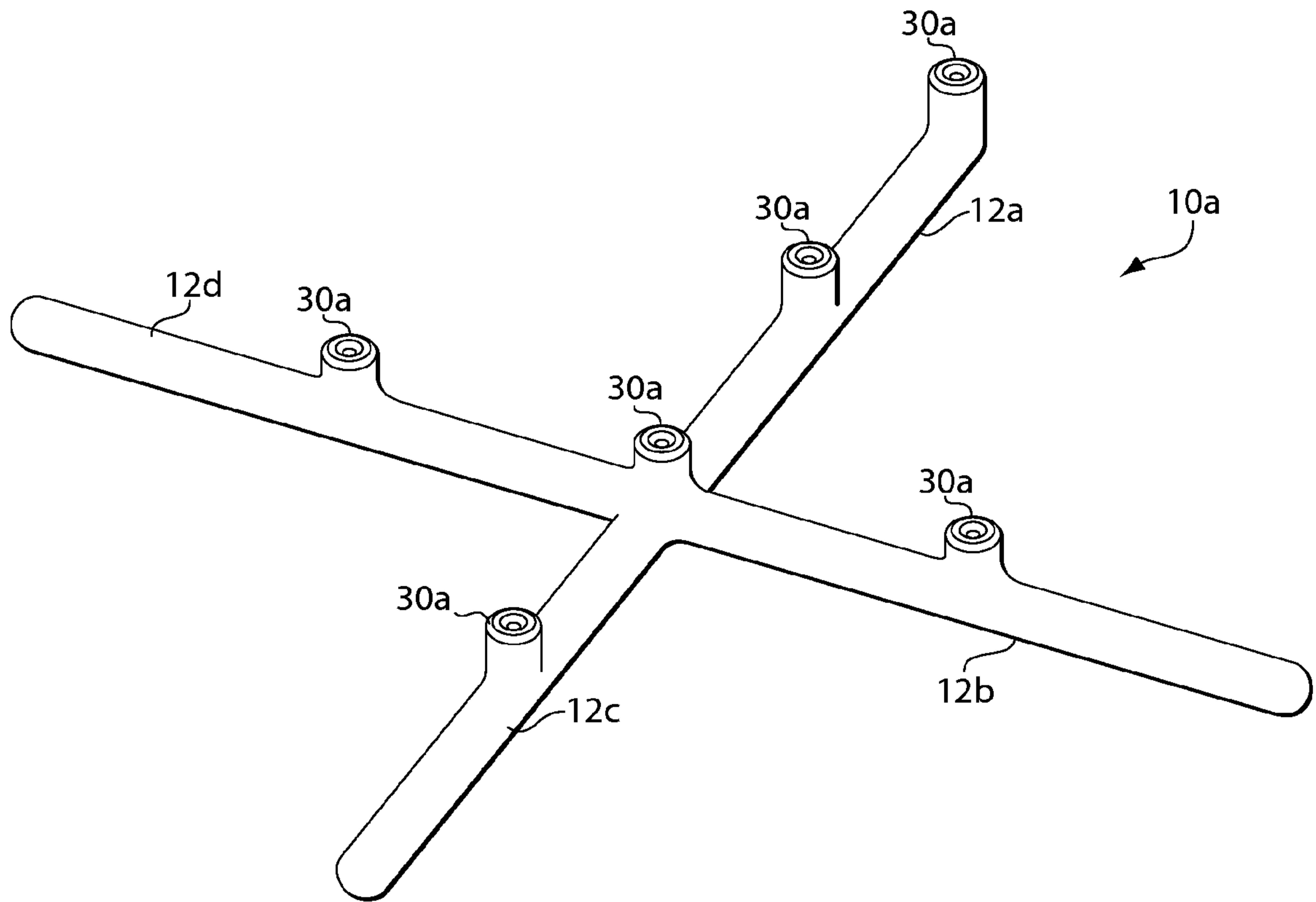

Fig. 8A

8/22

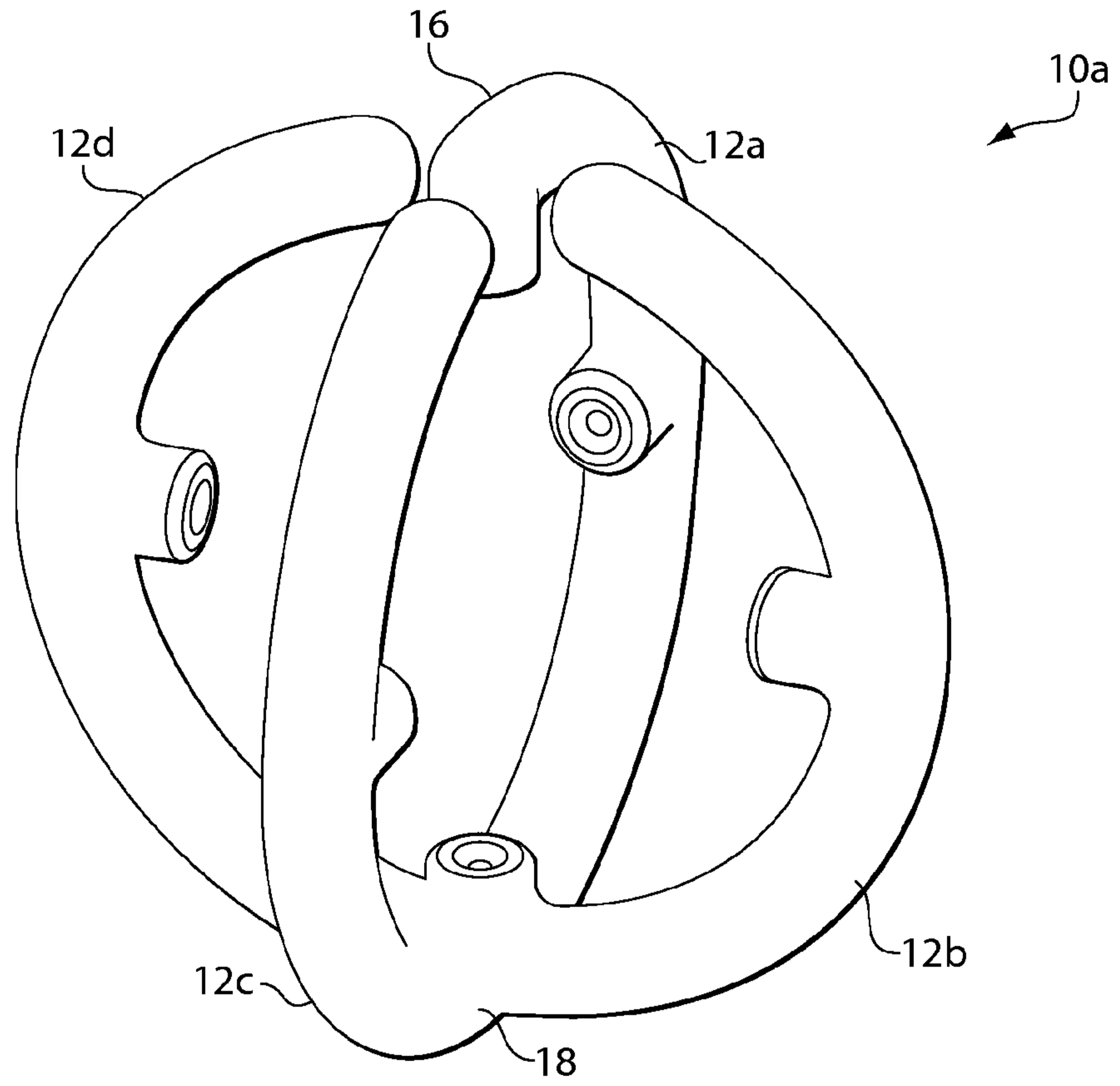

Fig. 8B

9/22

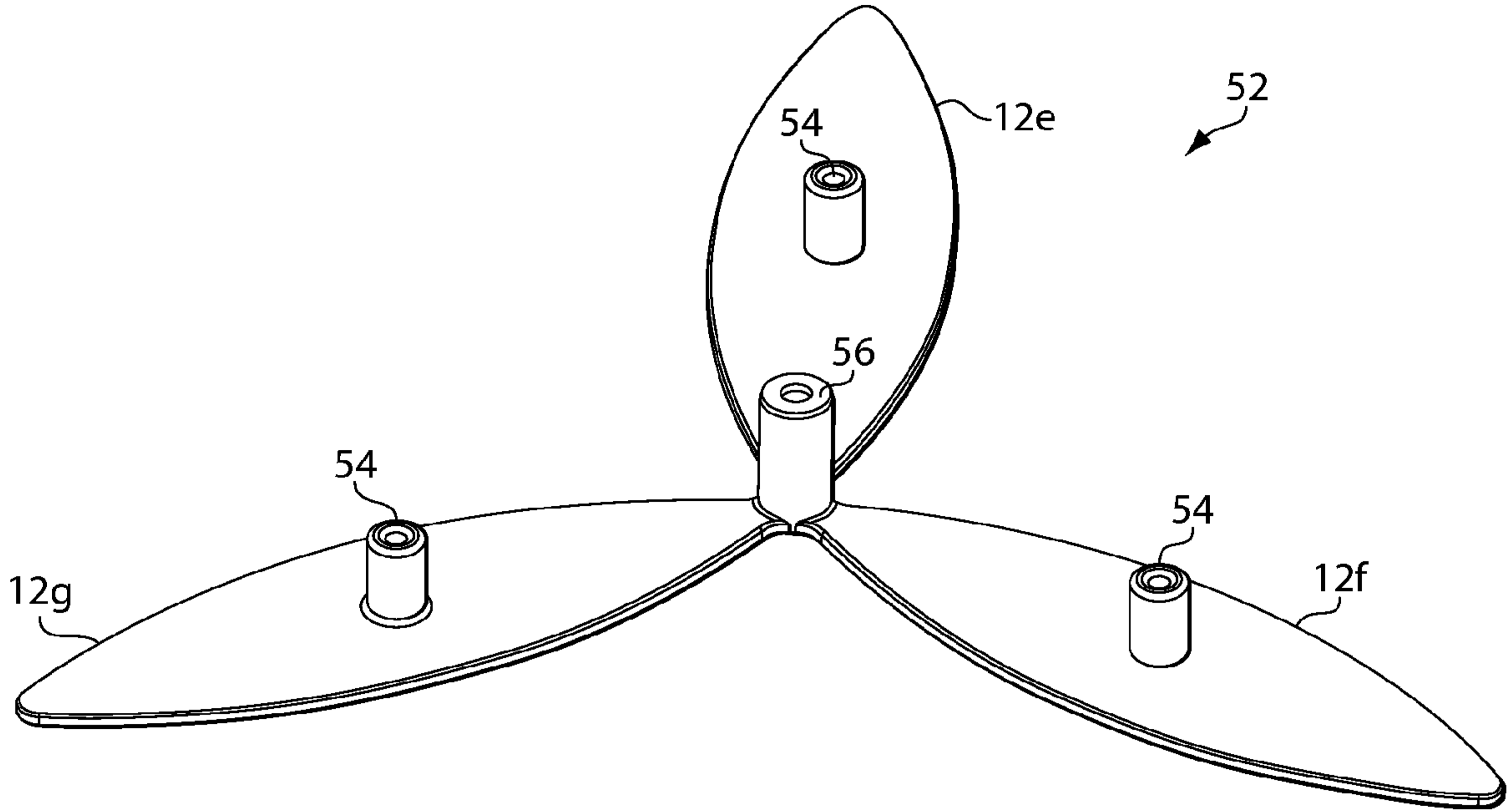

Fig. 9A

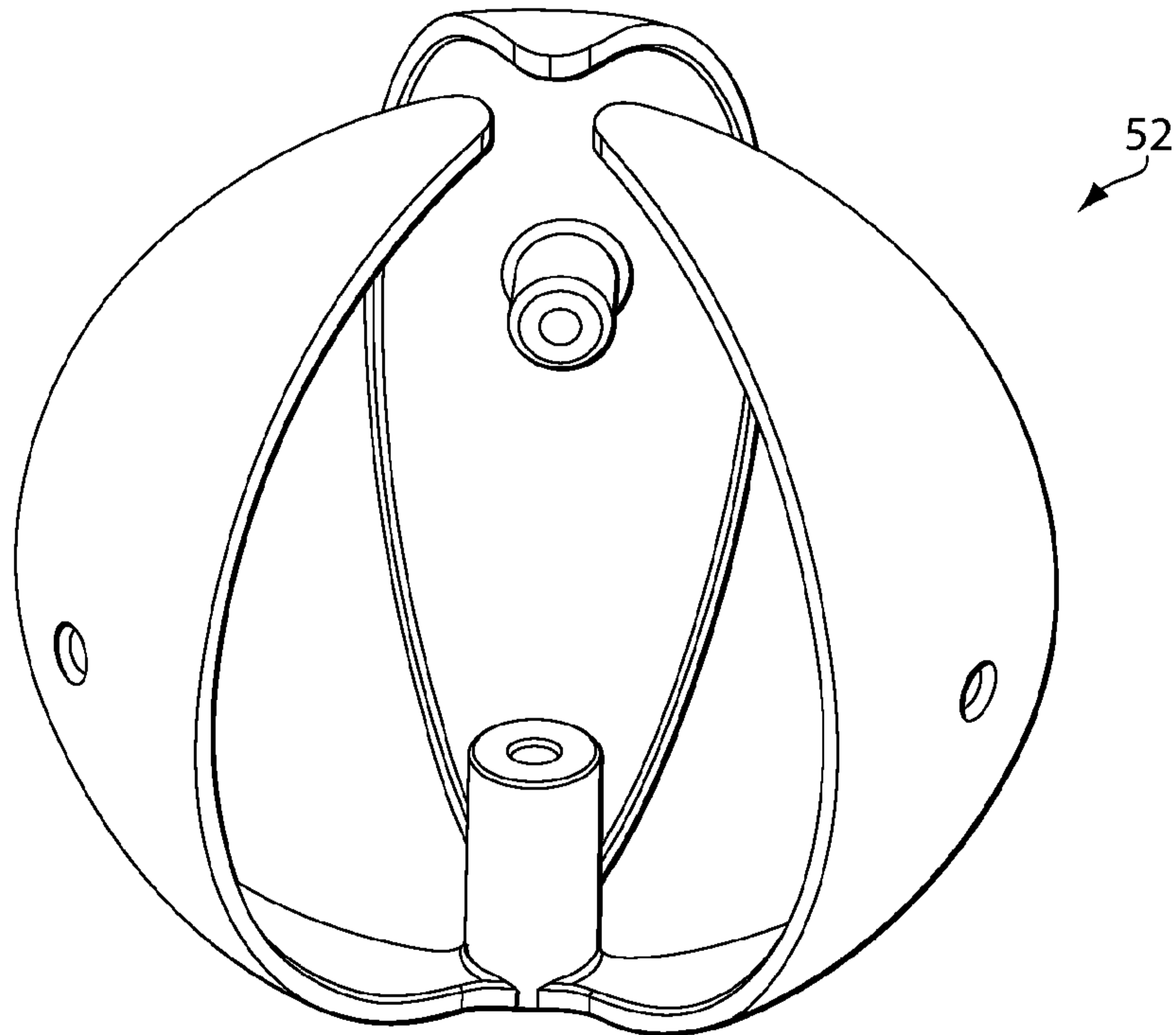

Fig. 9B

10/22

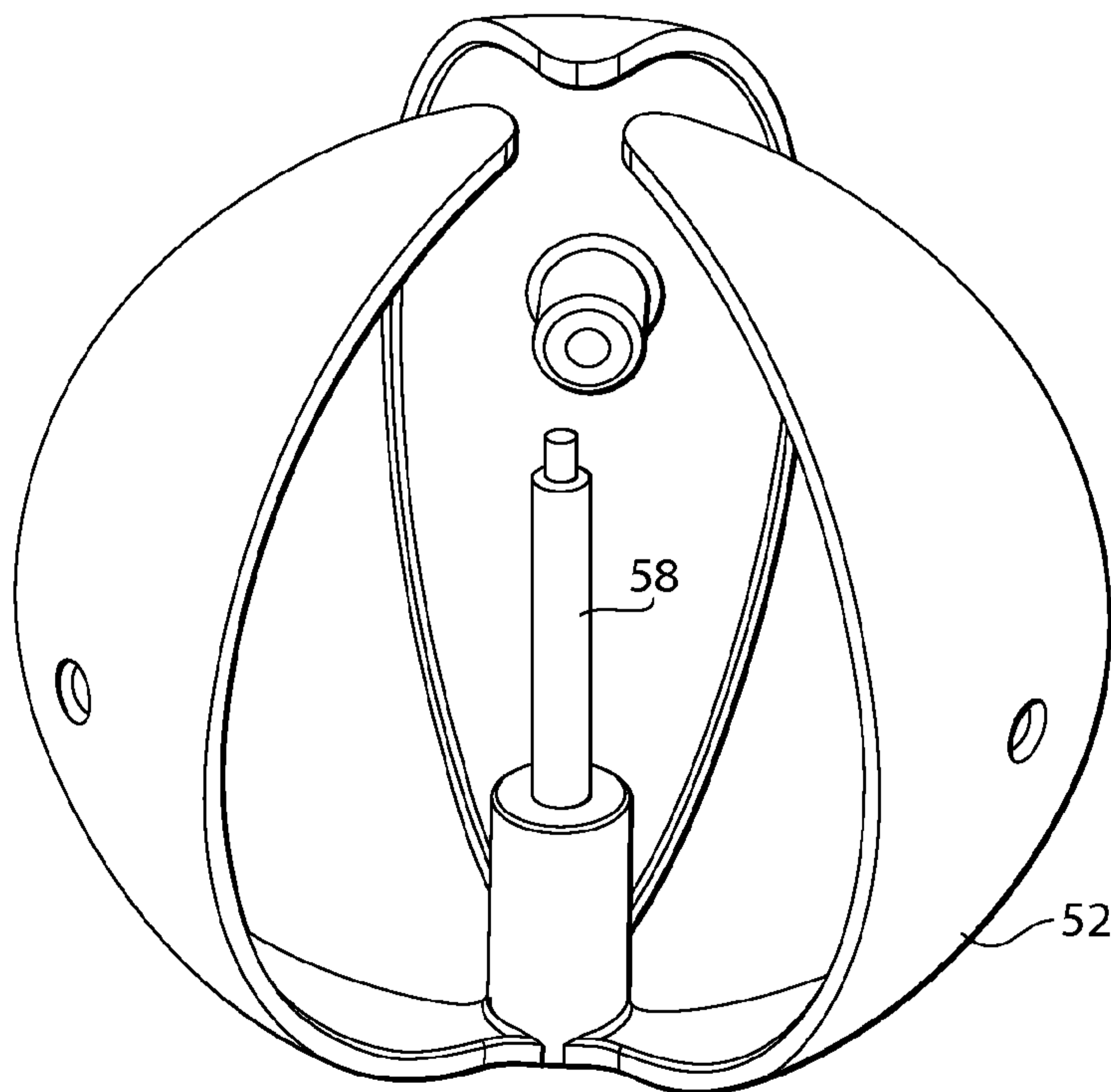
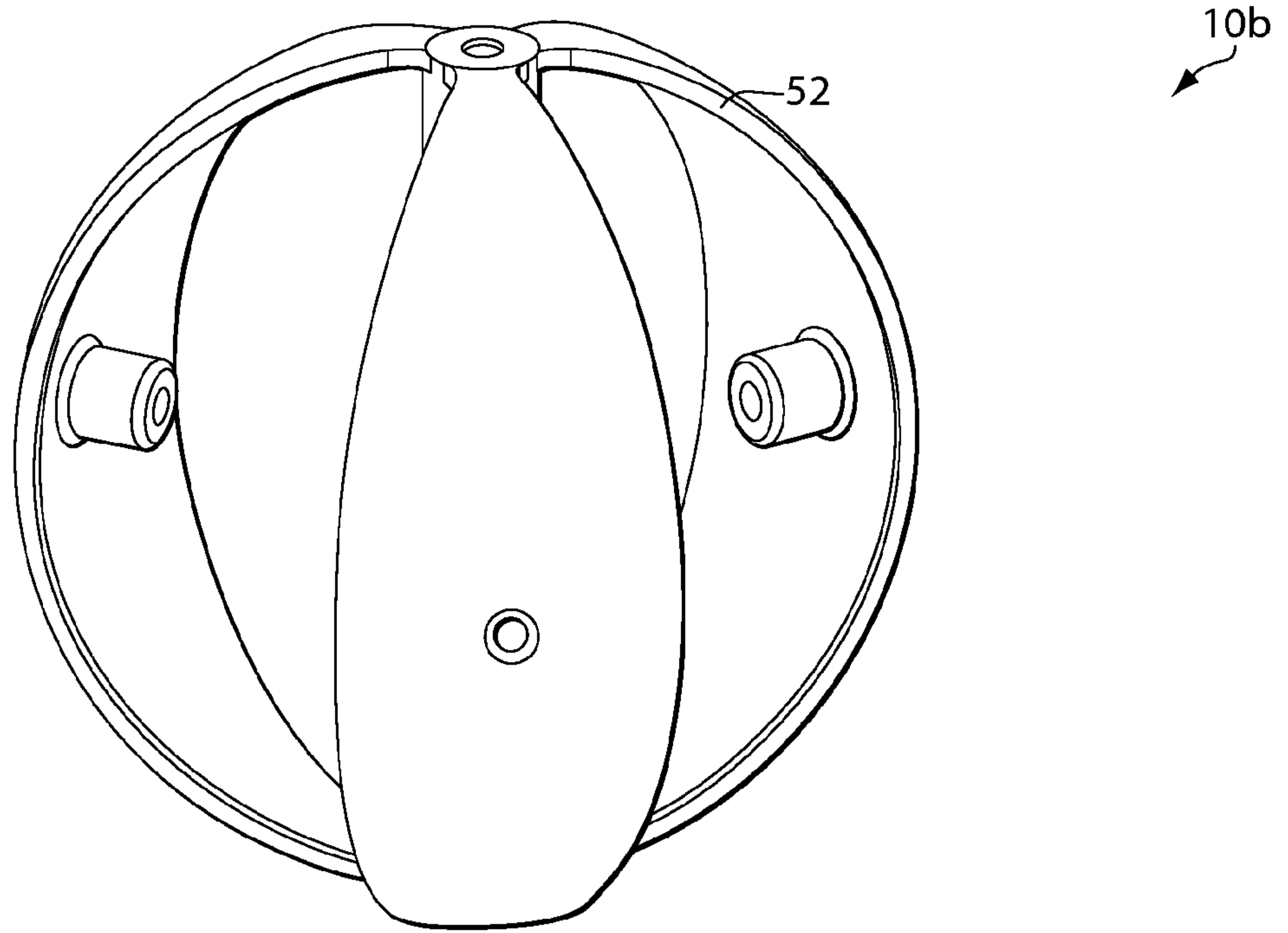

Fig. 9C

11/22

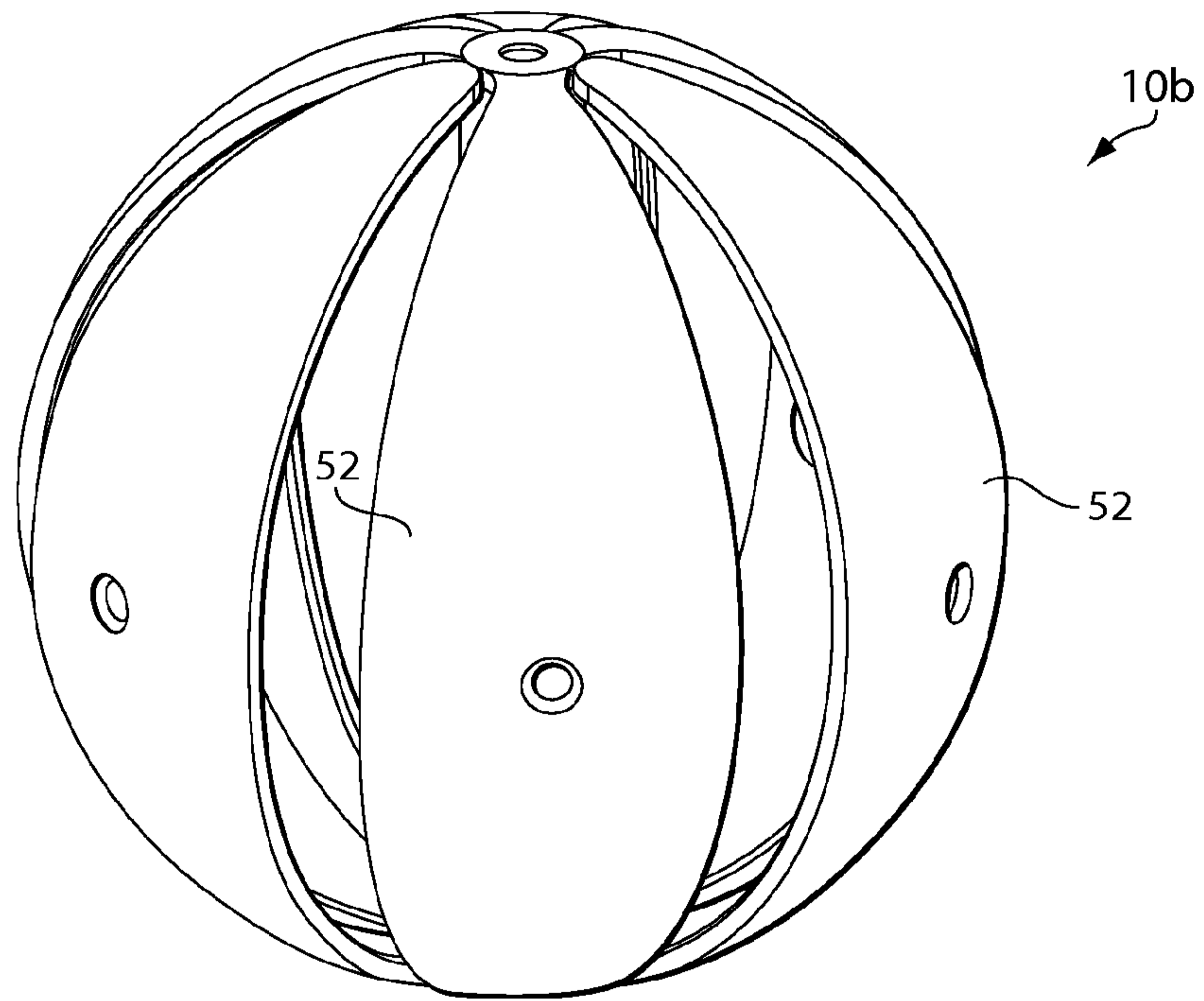

Fig. 9D

12/22

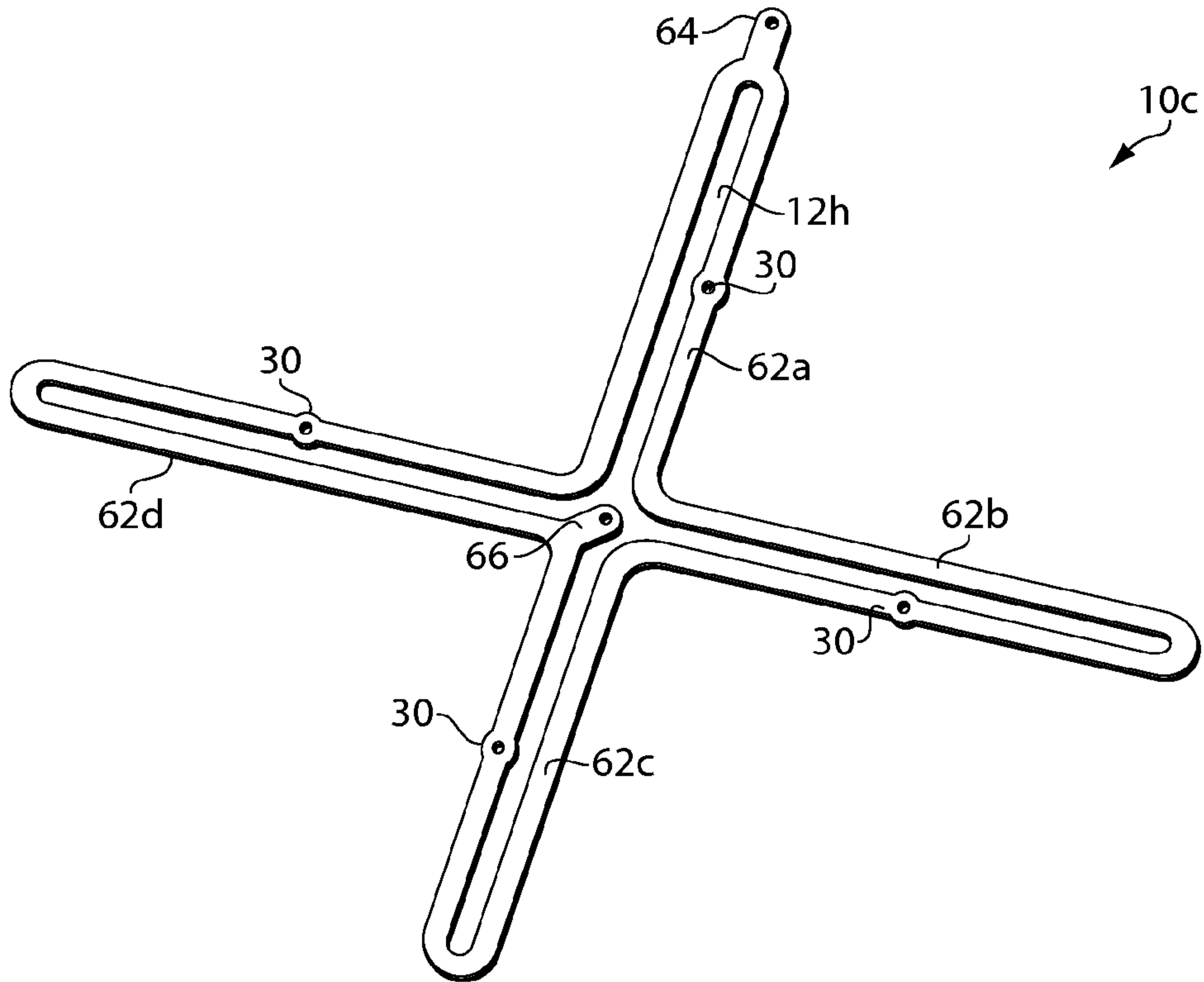

Fig. 10A

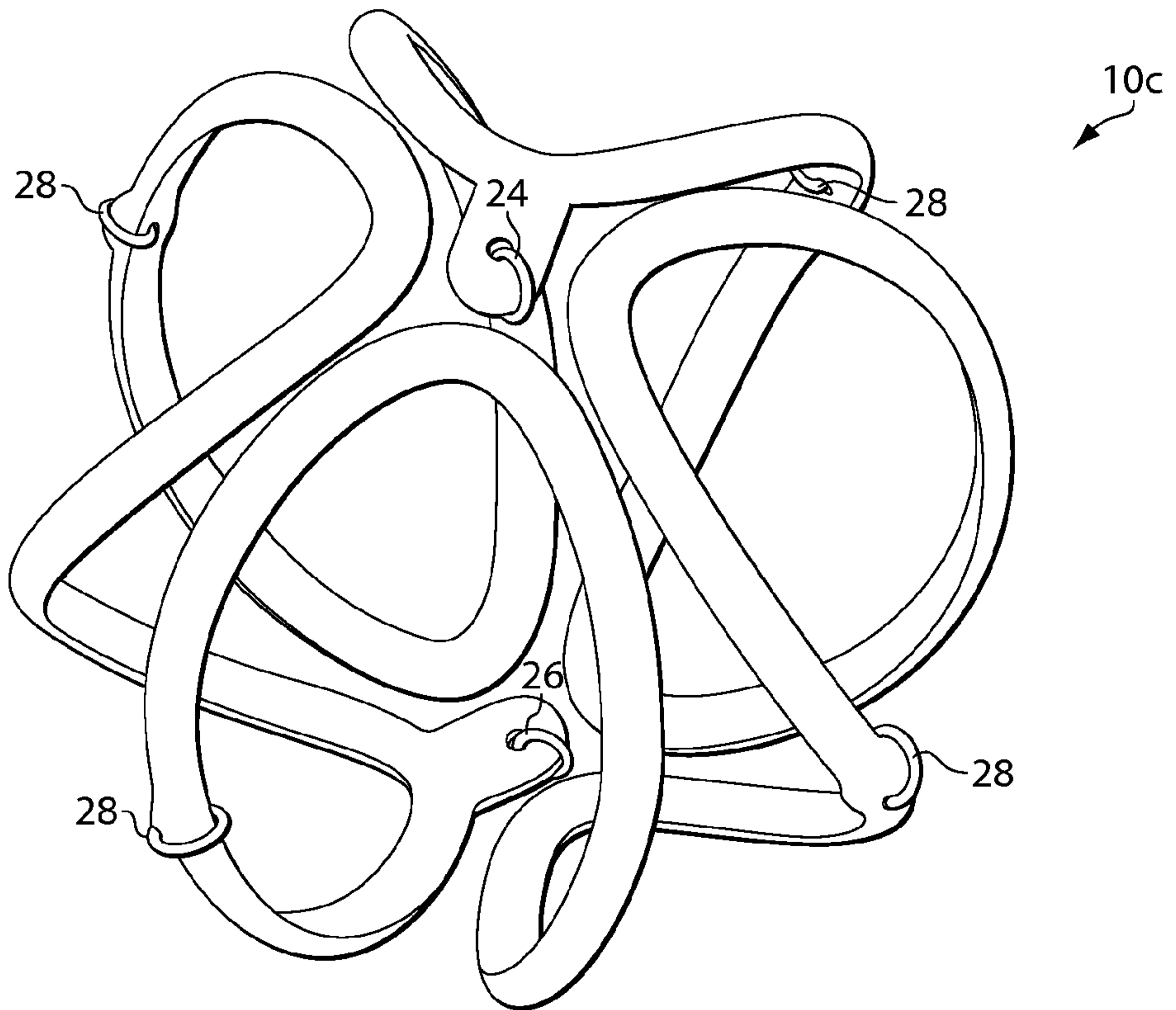

Fig. 10B

13/22

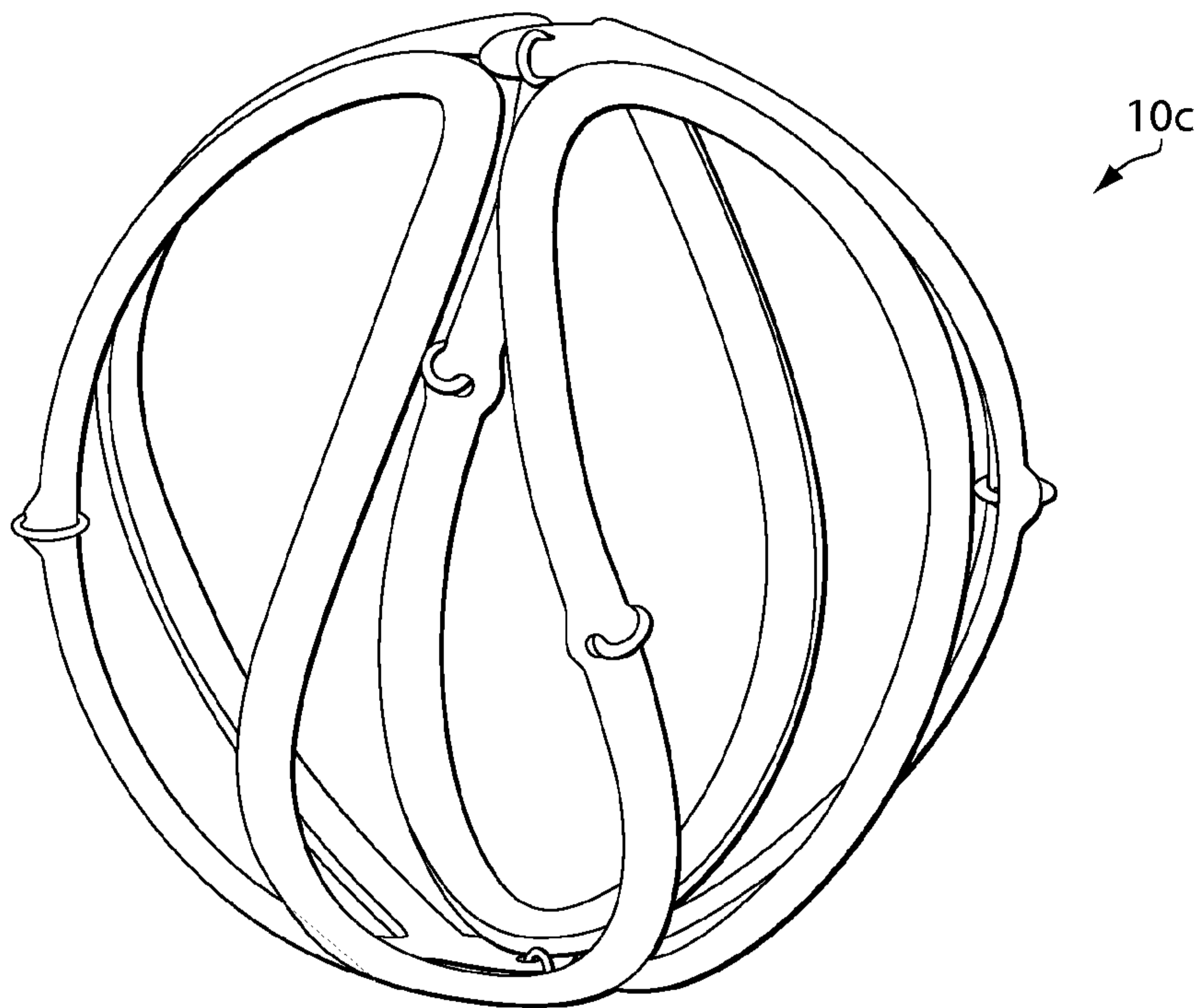

Fig. 10C

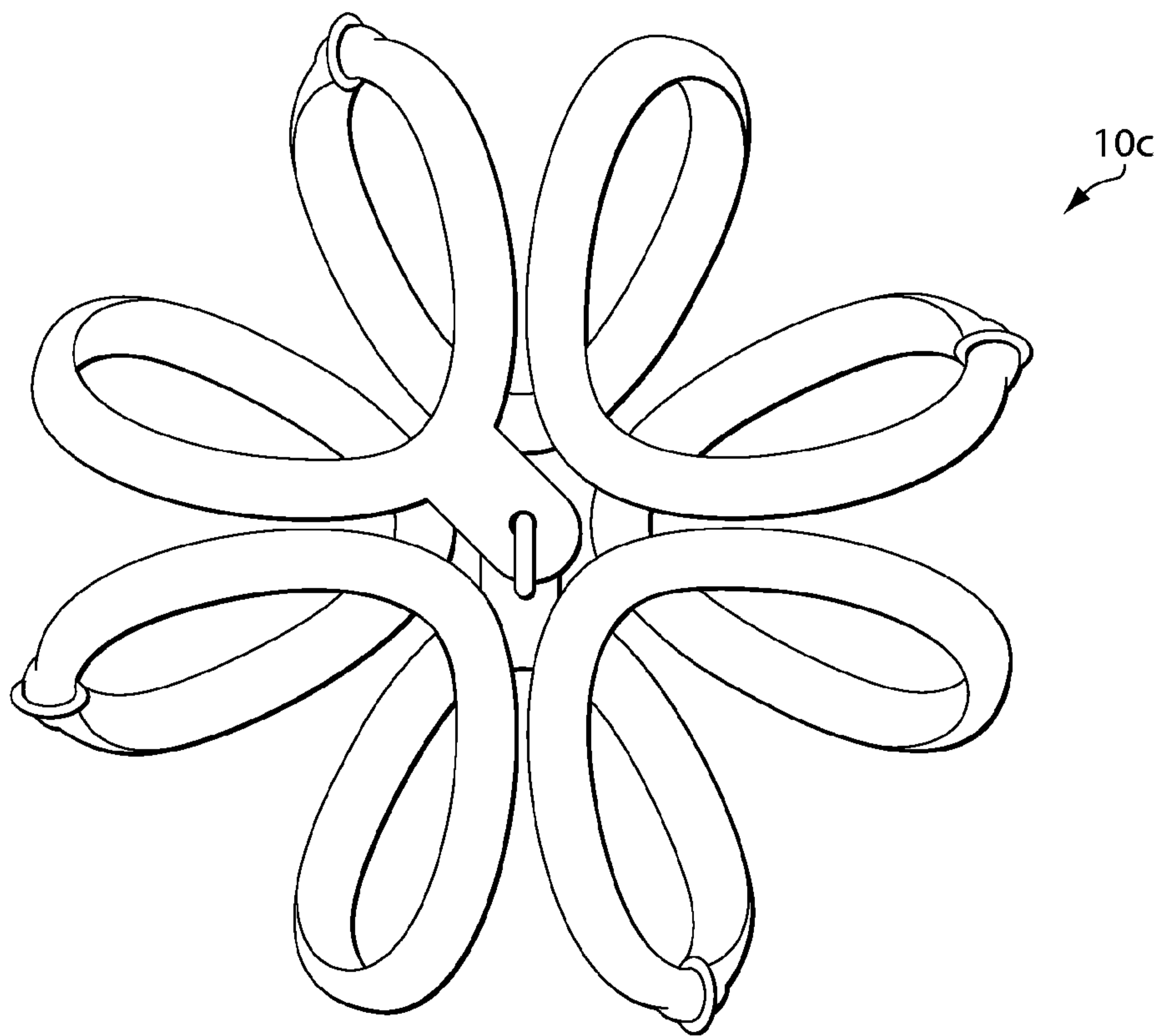

Fig. 10D

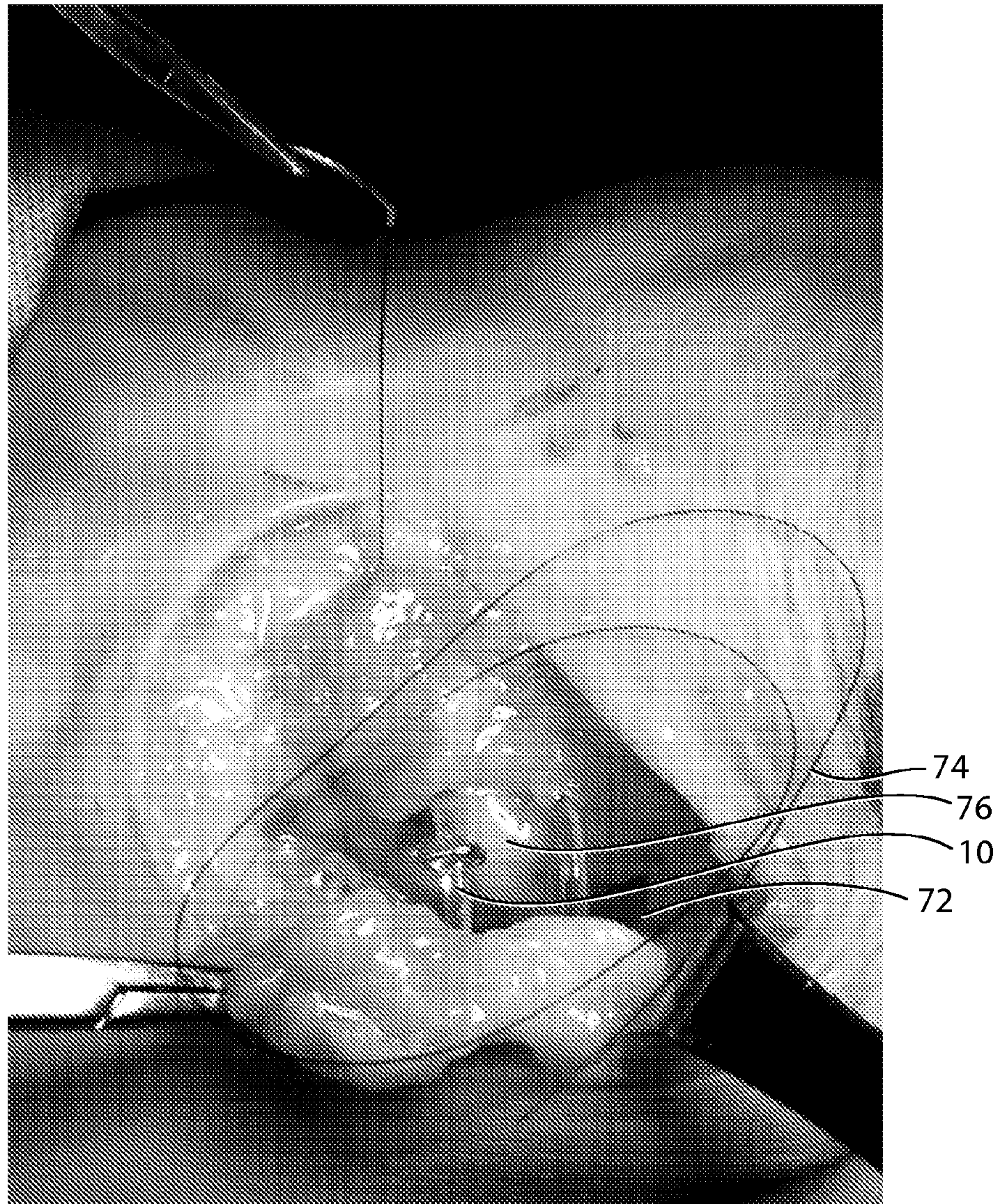

Fig. 11

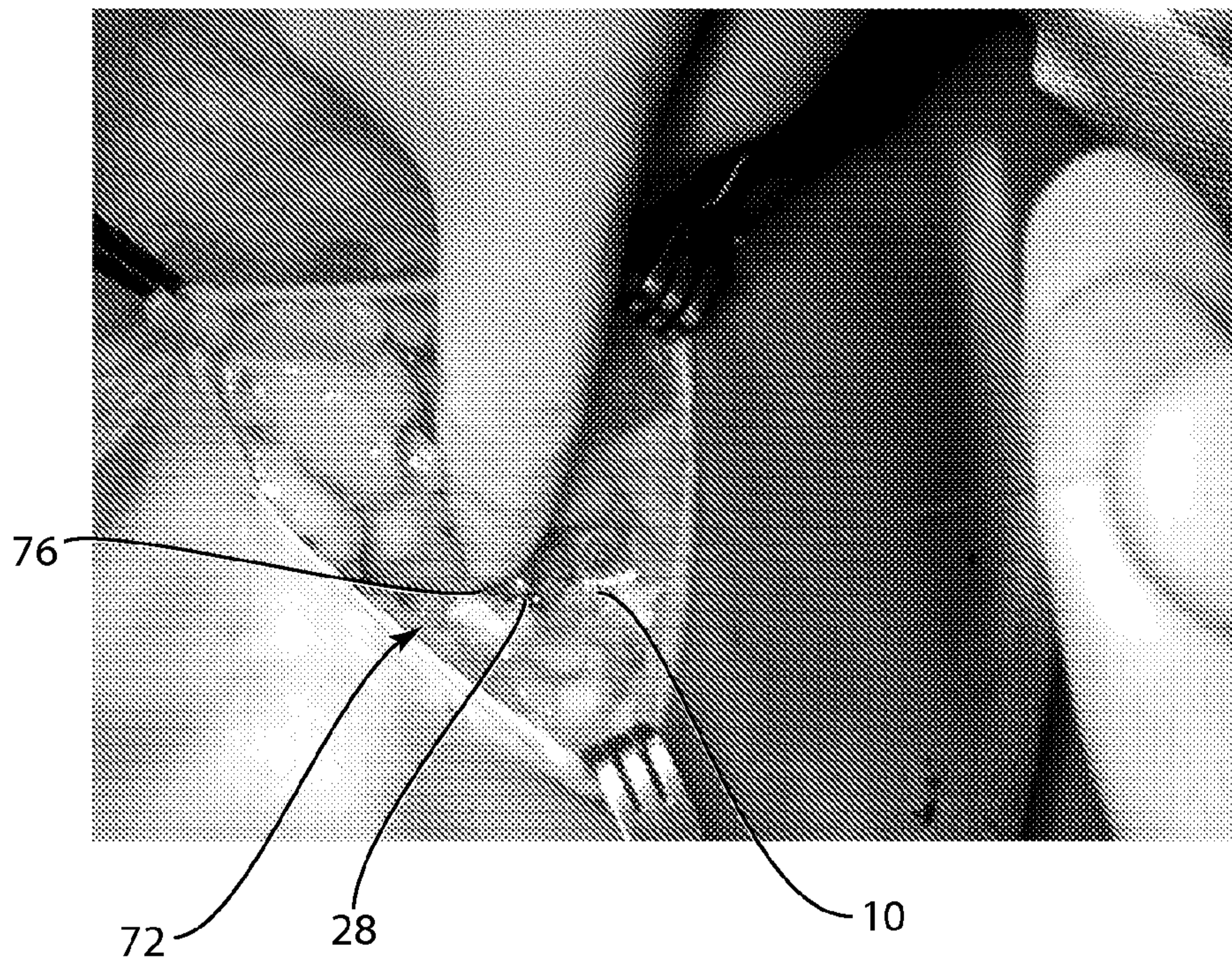

Fig. 12

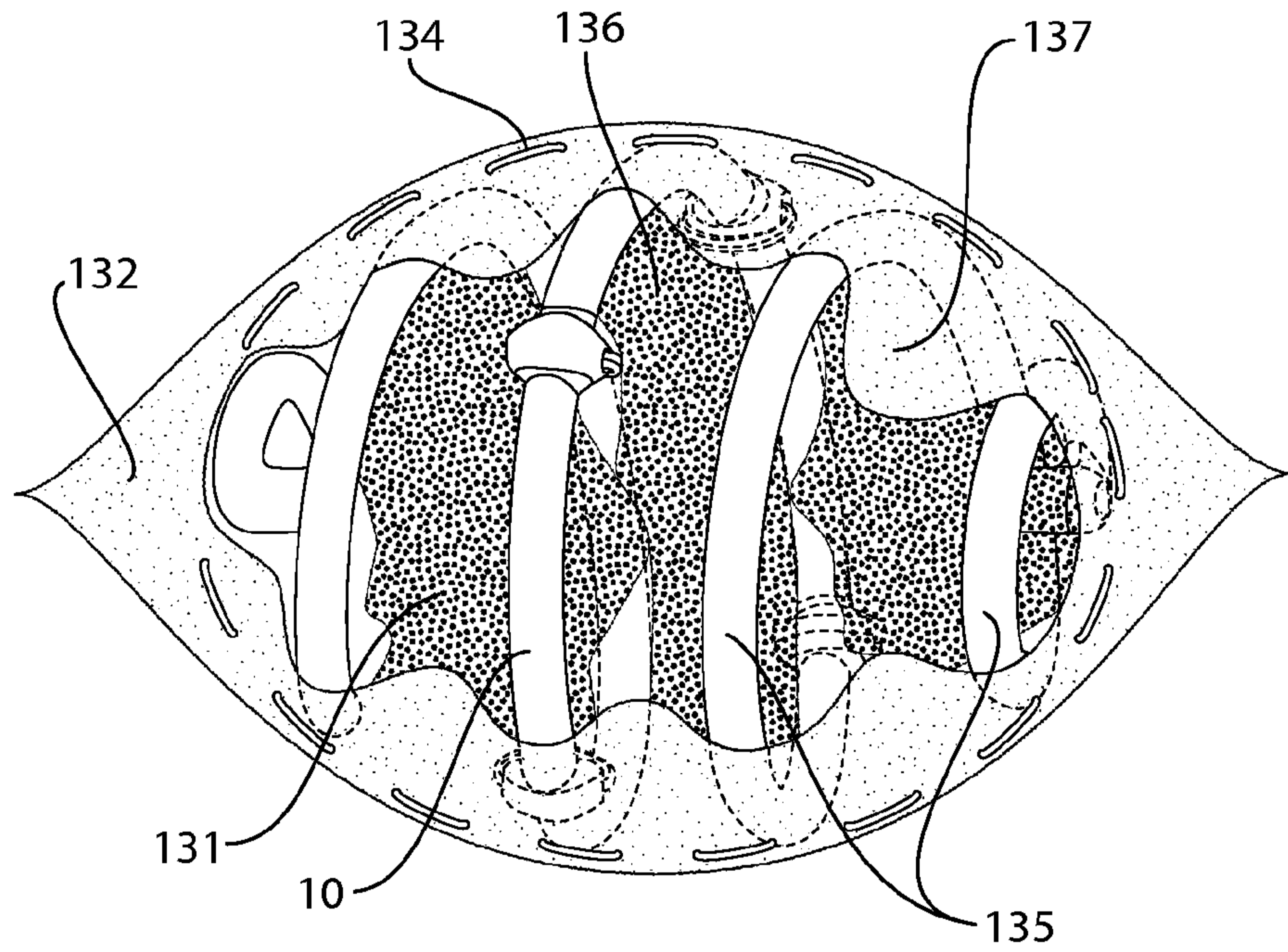
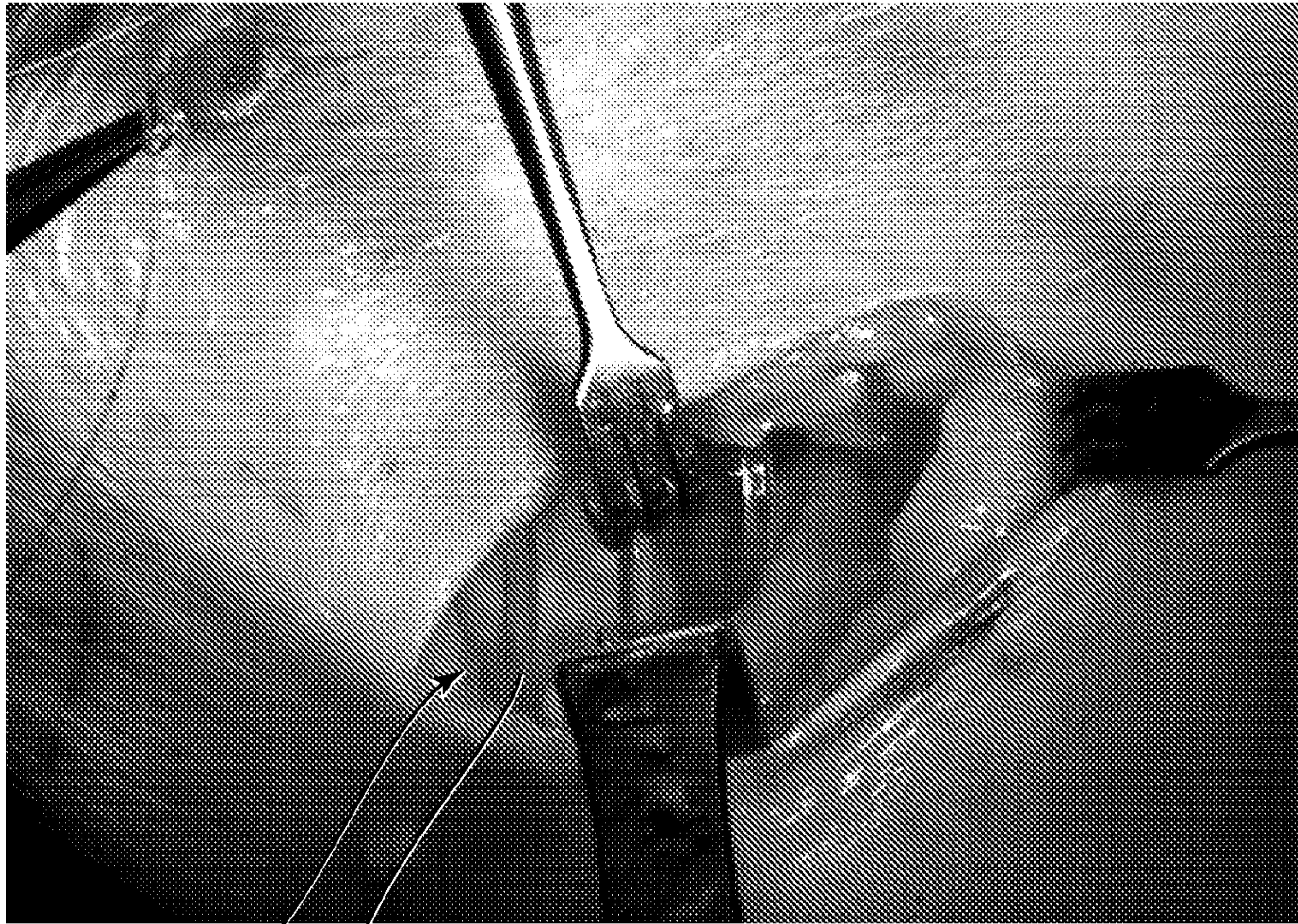

Fig. 13

17/22



72 10

Fig. 14

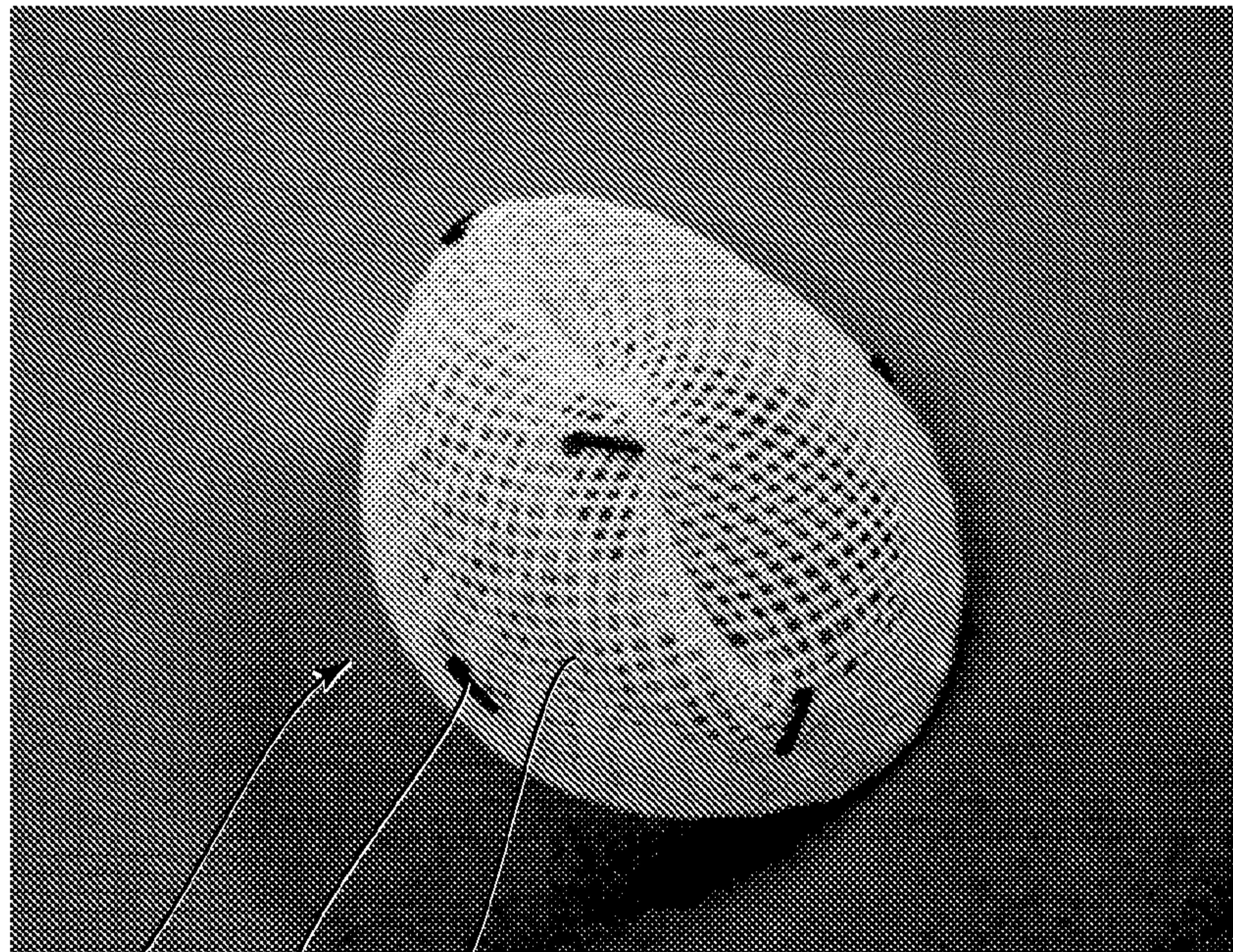

10d 84 82

Fig. 15

18/22

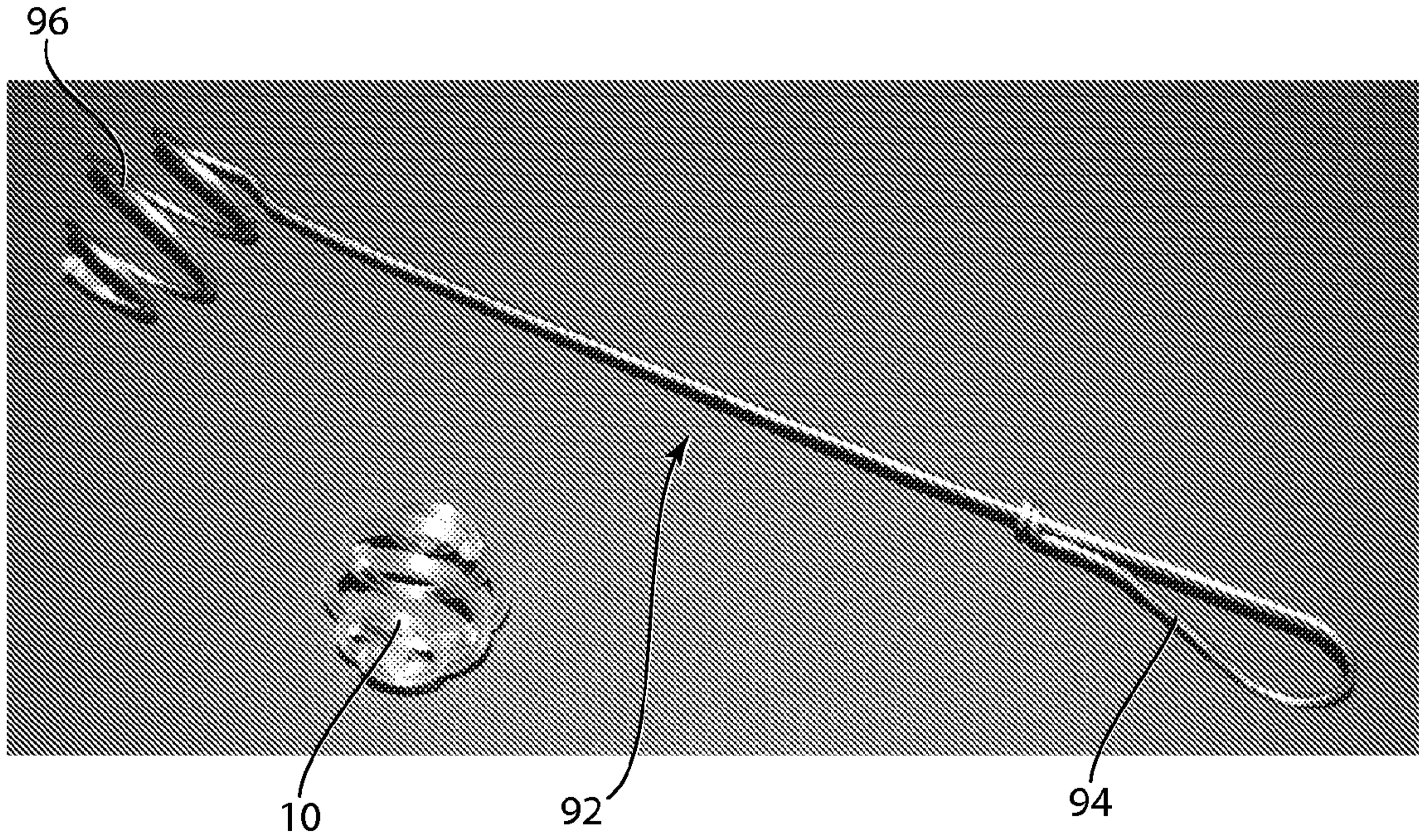

Fig. 16A

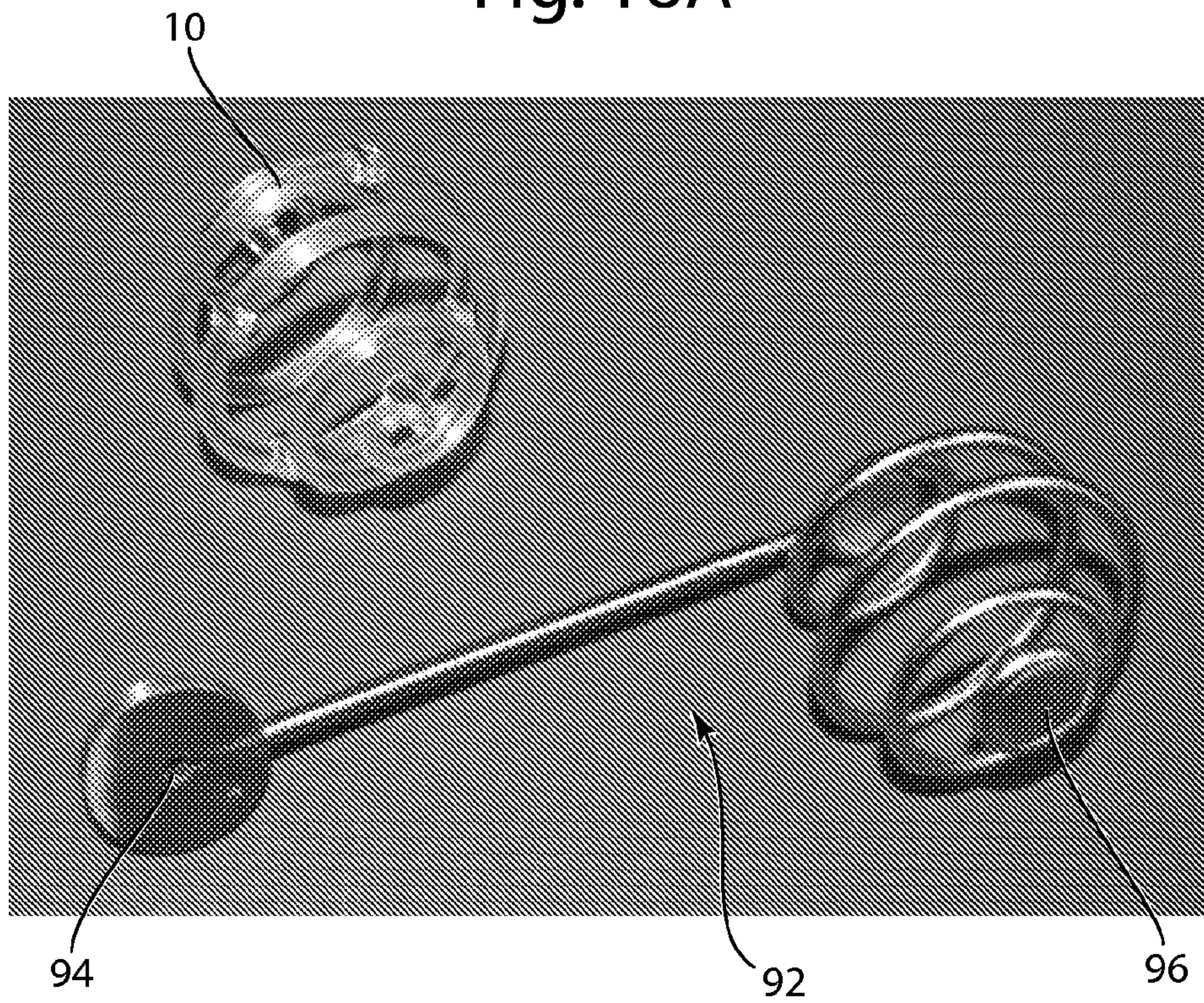

Fig. 16B

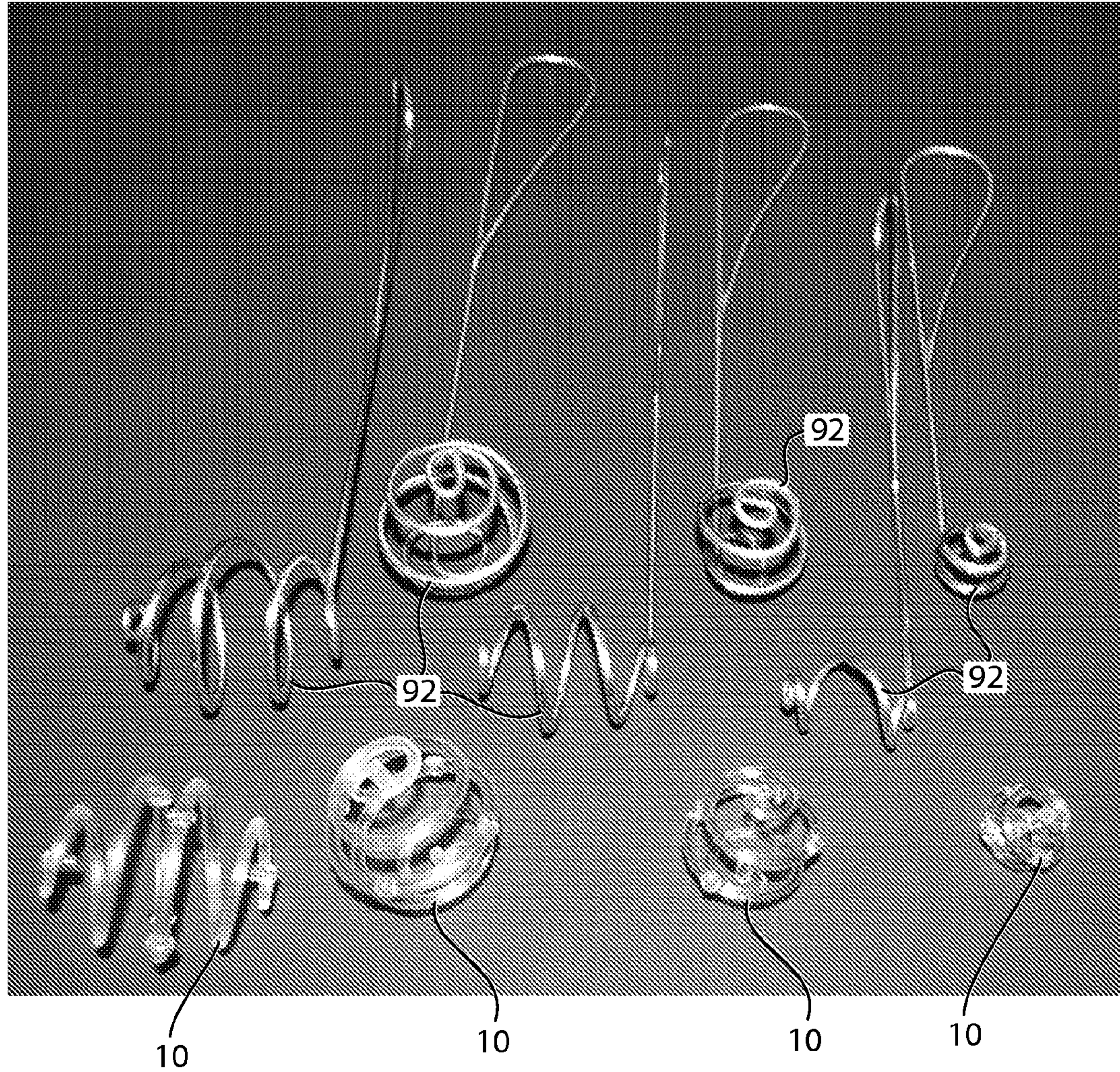

Fig. 16C

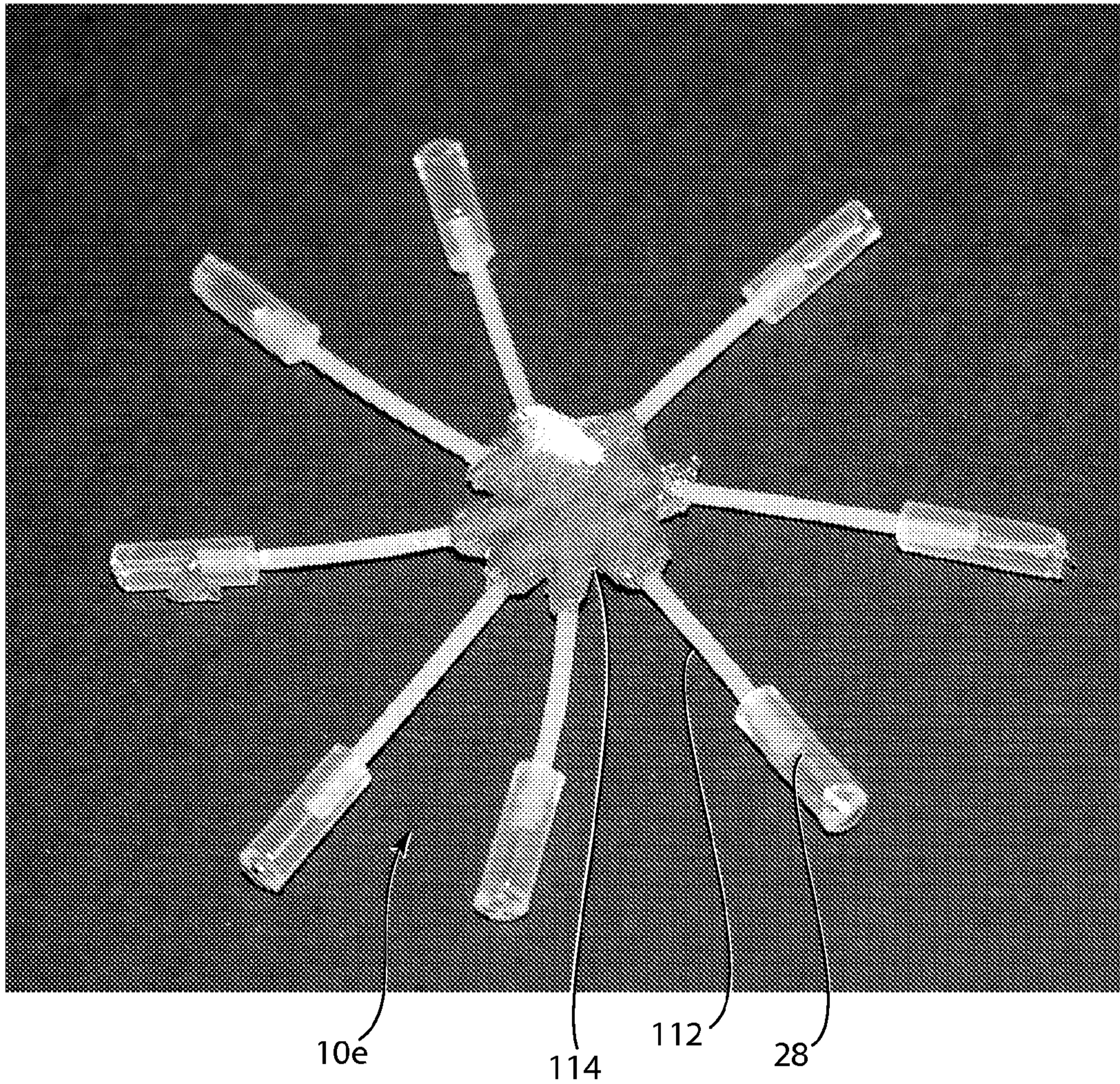

Fig. 17A

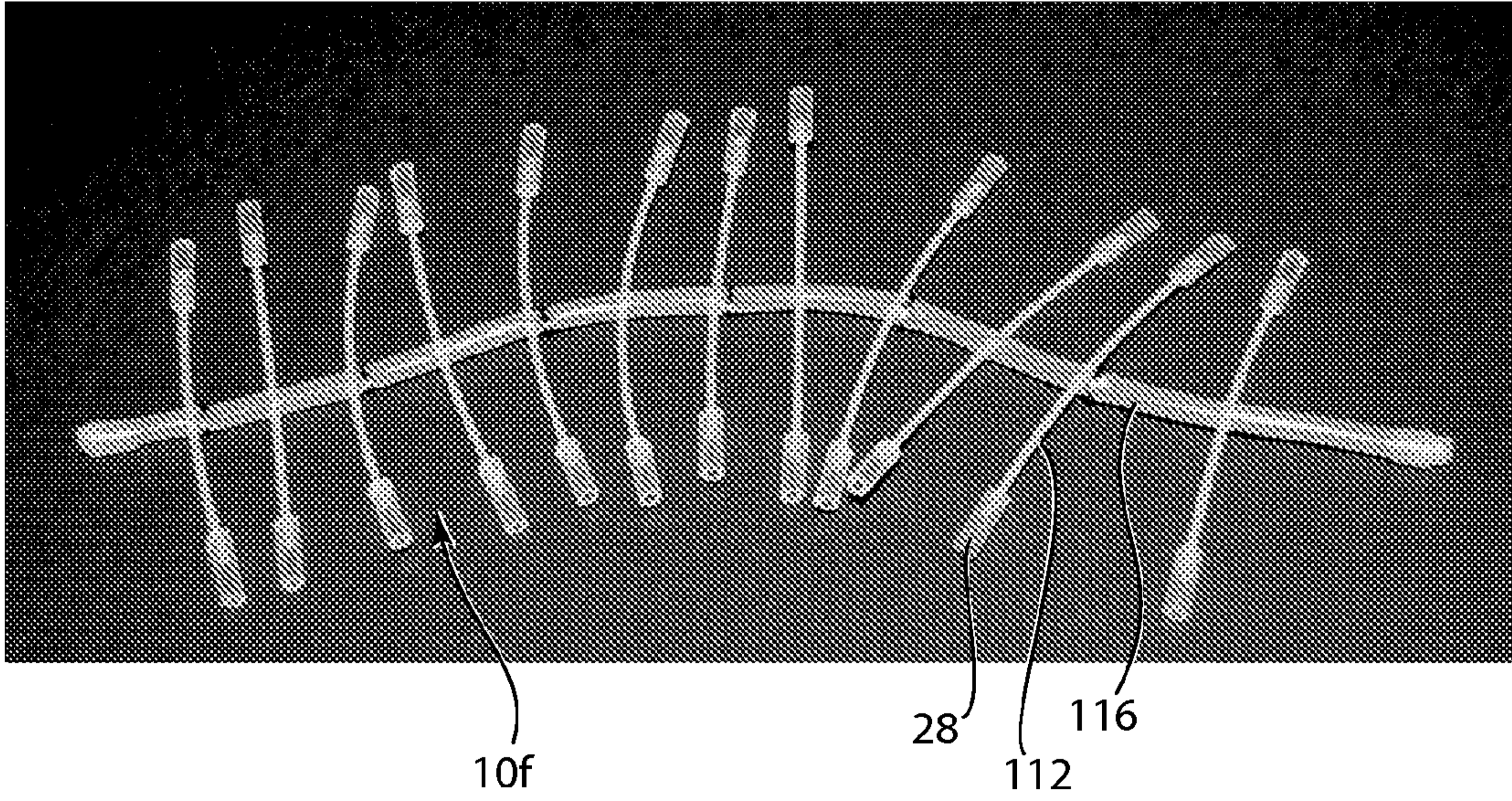

Fig. 17B

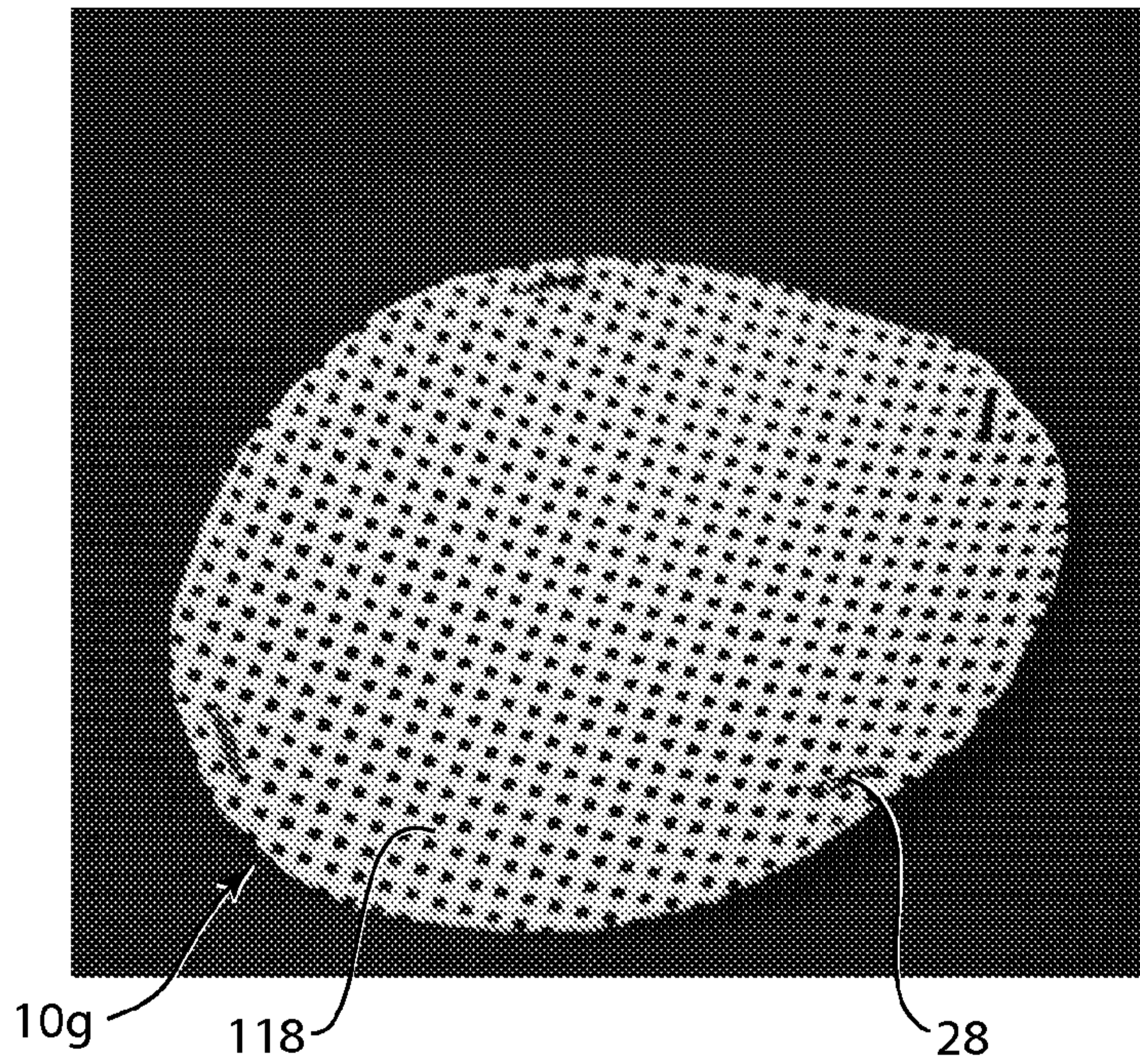

Fig. 18

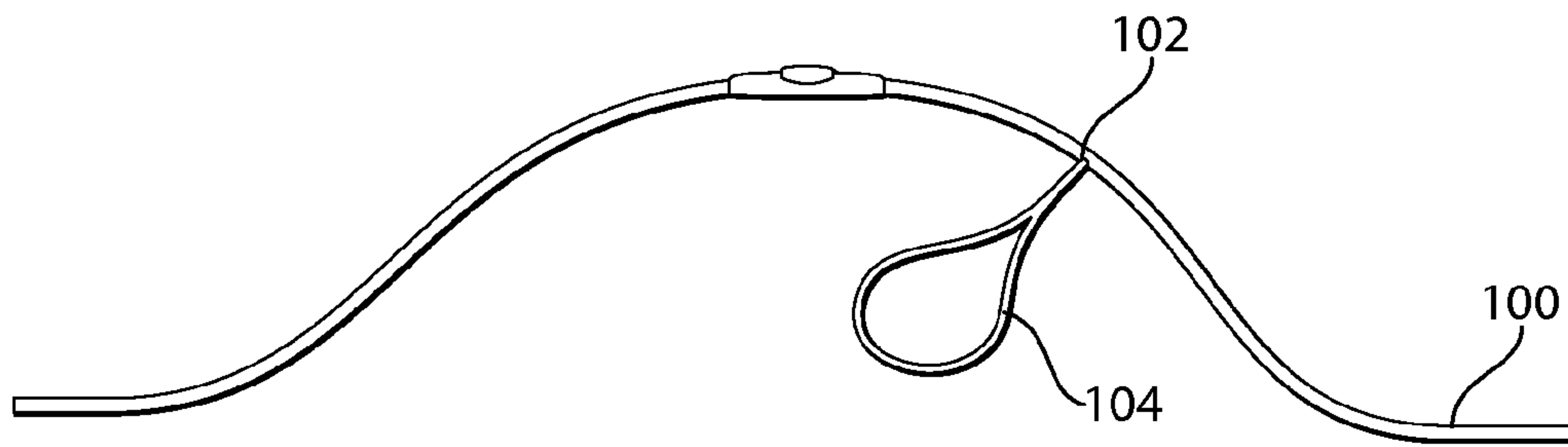

Fig. 19

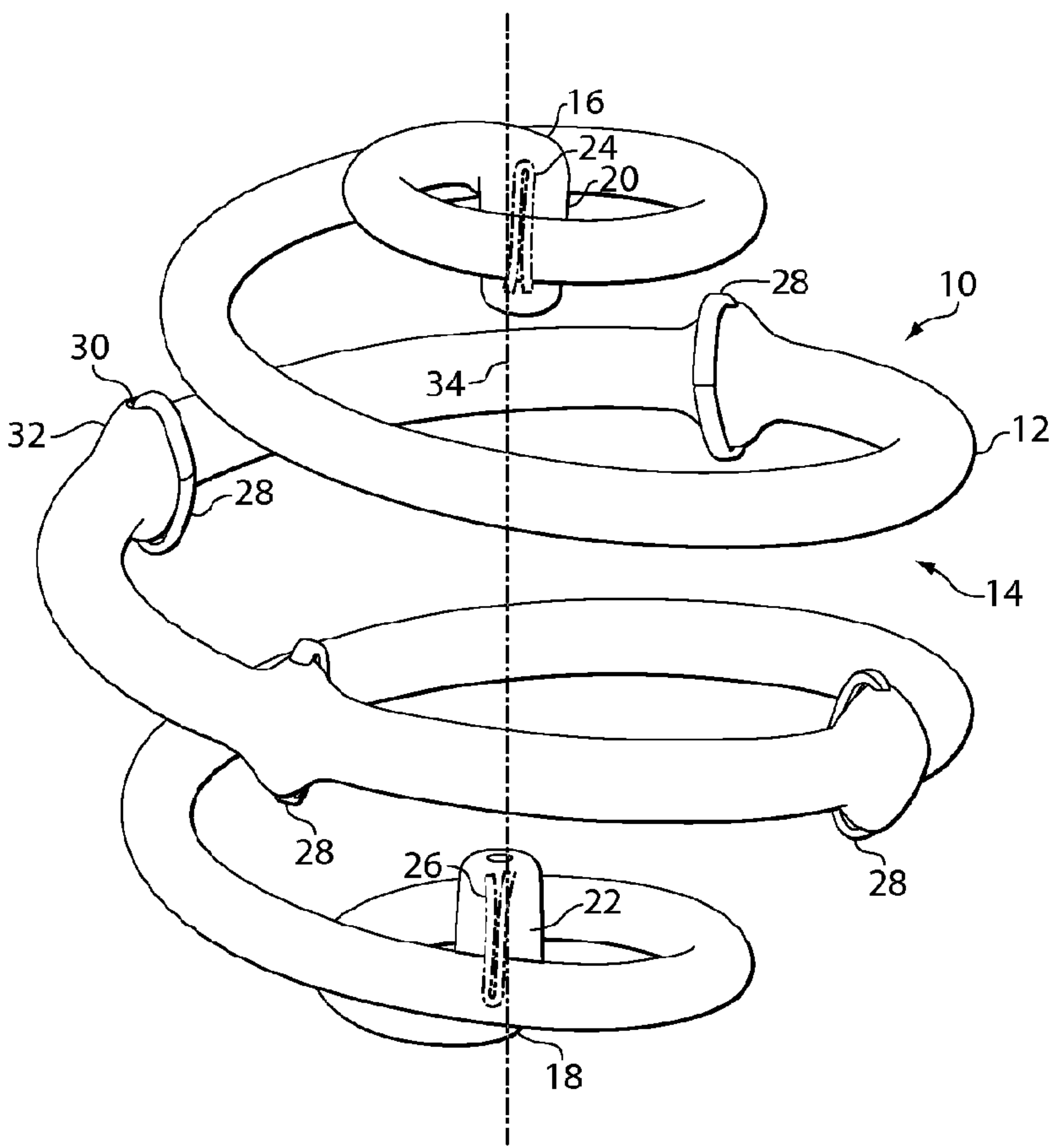

Fig. 1A

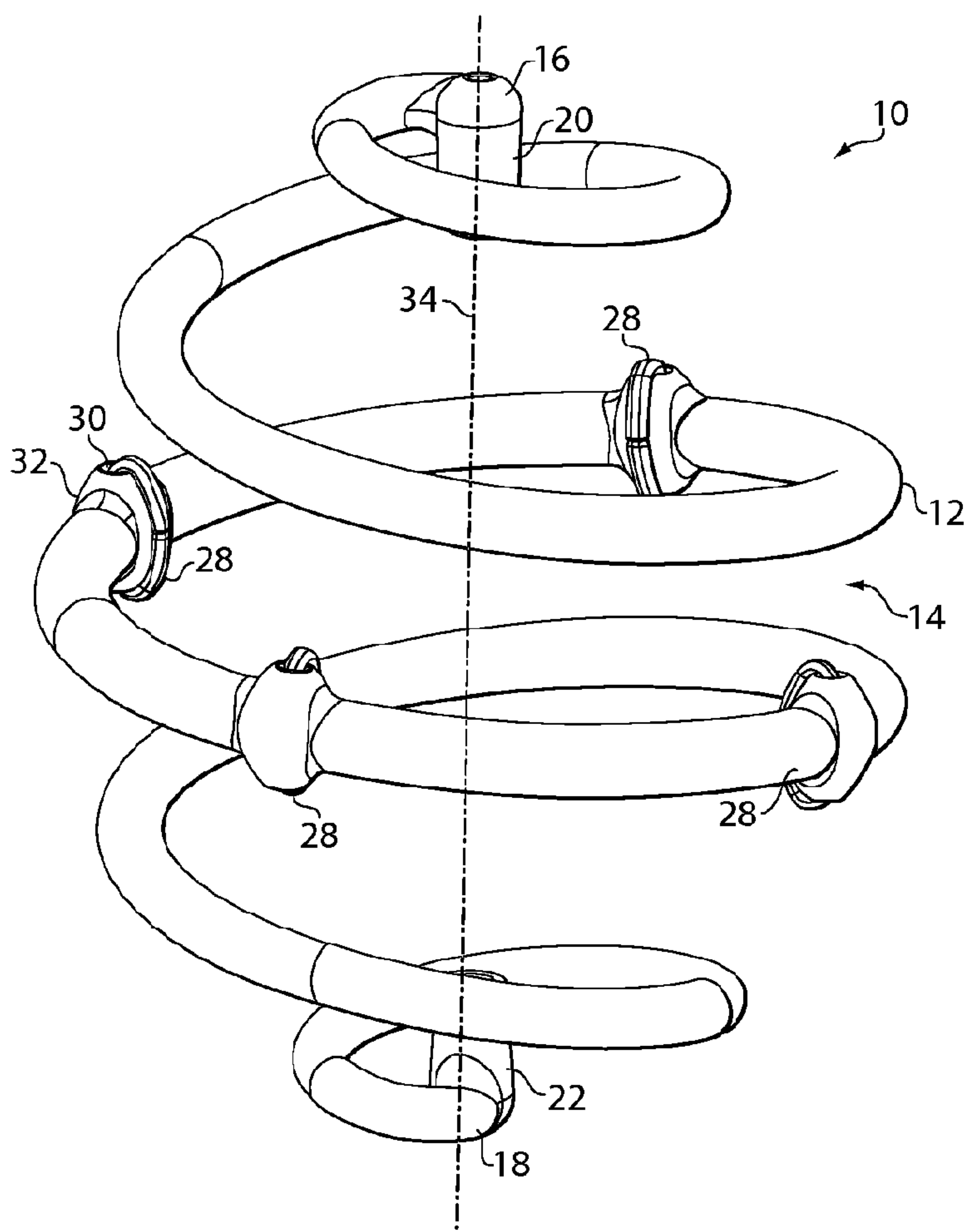

Fig. 1B