

(19) World Intellectual Property Organization  
International Bureau



(43) International Publication Date  
28 May 2009 (28.05.2009)

PCT

(10) International Publication Number  
WO 2009/065223 A1

- (51) International Patent Classification:  
G08B 23/00 (2006.01) H04R 3/00 (2006.01)  
G08B 29/00 (2006.01) H04R 3/02 (2006.01)
- (21) International Application Number:  
PCT/CA2008/002046
- (22) International Filing Date:  
20 November 2008 (20.11.2008)
- (25) Filing Language: English
- (26) Publication Language: English
- (30) Priority Data:  
2,611,462 22 November 2007 (22.11.2007) CA
- (71) Applicant (for all designated States except US): TYCO SAFETY PRODUCTS CANADA LTD. [CA/CA]; 3301 Langstaff Road, Concord, Ontario L4K 4L2 (CA).
- (72) Inventors; and
- (75) Inventors/Applicants (for US only): FOSTY, Stephen D. W. [CA/CA]; 12 Wolverton Crescent, Brampton, Ontario L6S 3L1 (CA). VANDENBERG, Michael J. [CA/CA]; 24 Main Street, Erin, Ontario N0B 1T0 (CA).
- (74) Agent: ZISCHKA, Matthew; SMART & BIGGAR, 438 University Avenue, Suite 1500, Box 111, Toronto, Ontario M5G 2K8 (CA).

- (81) Designated States (unless otherwise indicated, for every kind of national protection available): AE, AG, AL, AM, AO, AT, AU, AZ, BA, BB, BG, BH, BR, BW, BY, BZ, CA, CH, CN, CO, CR, CU, CZ, DE, DK, DM, DO, DZ, EC, EE, EG, ES, FI, GB, GD, GE, GH, GM, GT, HN, HR, HU, ID, IL, IN, IS, JP, KE, KG, KM, KN, KP, KR, KZ, LA, LC, LK, LR, LS, LT, LU, LY, MA, MD, ME, MG, MK, MN, MW, MX, MY, MZ, NA, NG, NI, NO, NZ, OM, PG, PH, PL, PT, RO, RS, RU, SC, SD, SE, SG, SK, SL, SM, ST, SV, SY, TJ, TM, TN, TR, TT, TZ, UA, UG, US, UZ, VC, VN, ZA, ZM, ZW.
- (84) Designated States (unless otherwise indicated, for every kind of regional protection available): ARIPO (BW, GH, GM, KE, LS, MW, MZ, NA, SD, SL, SZ, TZ, UG, ZM, ZW), Eurasian (AM, AZ, BY, KG, KZ, MD, RU, TJ, TM), European (AT, BE, BG, CH, CY, CZ, DE, DK, EE, ES, FI, FR, GB, GR, HR, HU, IE, IS, IT, LT, LU, LV, MC, MT, NL, NO, PL, PT, RO, SE, SI, SK, TR), OAPI (BF, BJ, CF, CG, CI, CM, GA, GN, GQ, GW, ML, MR, NE, SN, TD, TG).

Declaration under Rule 4.17:  
— as to applicant's entitlement to apply for and be granted a patent (Rule 4.17(ii))

[Continued on next page]

(54) Title: ALARM SYSTEM AUDIO INTERFACE TAMPER AND STATE DETECTION

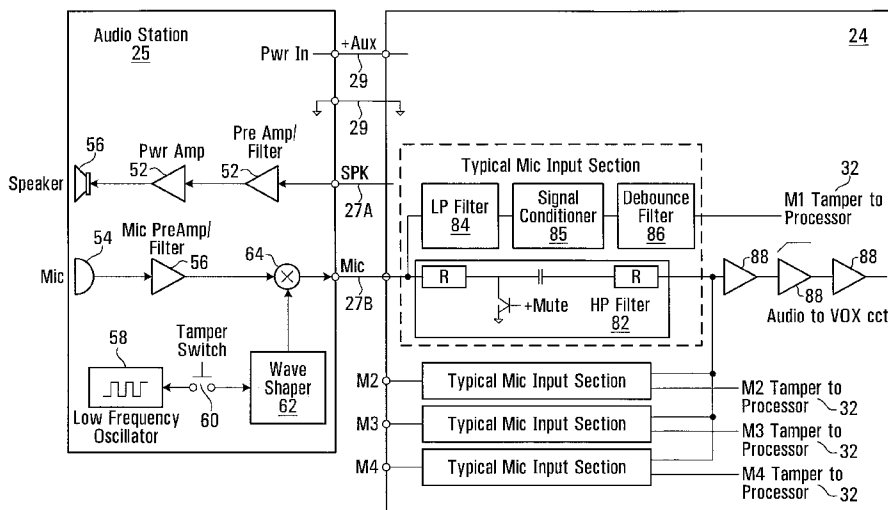

FIG. 3

(57) Abstract: An alarm system comprises: an audio interface comprising: a microphone; a state sensor for sensing a state at the audio interface; a signal generator for generating an inaudible state signal indicative of the state; a multiplexer for combining an audio signal from the microphone and the state signal; a control panel for monitoring sensed conditions at the audio interface; a conductor interconnecting the audio interface to the control panel carrying audio signal and the state signal as combined from the audio interface to the control panel.

WO 2009/065223 A1



---

**Published:**

— *with international search report*

## ALARM SYSTEM AUDIO INTERFACE TAMPER AND STATE DETECTION

### FIELD OF THE INVENTION

**[0001]** The present invention relates generally to alarm systems, and more particularly to an alarm including an audio interface, and the detection of a state or tampering at the audio interface.

### BACKGROUND OF THE INVENTION

**[0002]** Home and business alarms have become commonplace. Such alarms (often referred to as "security systems" or "alarm systems") typically include several sensors used to monitor unauthorized entry and other conditions at monitored premises, such as fire, smoke, toxic gases, high/low temperature (e.g. freezing) or flooding, at a premises. In response to sensing an alarm condition, a sensor provides a signal to an alarm panel that in turn may sound and notify the occurrence of the alarm to occupants of the premises and remotely signal a monitoring center or other third party.

**[0003]** Typically the occurrence of an alarm is signalled to a remote monitoring center that may then dispatch capable authorities to intervene at the premises. For example, in the case of sensing an unauthorized entry to the premises, the monitoring center may dispatch security personnel, typically in the form of private security guards or police officers.

**[0004]** Additionally, many alarm systems now allow audio communication with the monitoring center. Such audio communication may be one-way (e.g. from the premises to the station) or two-way (i.e. from and to the premises/monitoring center). In this way, the alarm system may be used to audibly monitor the premises during an alarm condition, or it may be used to dispatch a verbal request for help by an

occupant at the monitored premises. To this end, some alarm systems are equipped with an audio interface, including a microphone and optionally a speaker.

**[0005]** Communication between the premises and the monitoring station typically takes place over a communications network, for example by way of the public switched telephone network (PSTN).

**[0006]** Unfortunately, audio interfaces are susceptible to unauthorized modification, or disconnection by intruders or others. Tampering can be deterred by encasing the audio interface. This however, is costly and cumbersome. Alternatively, tampering can be detected.

**[0007]** Accordingly there is a need for alarm systems and audio interfaces that allow tamper detection.

## SUMMARY OF THE INVENTION

**[0008]** In accordance with an aspect of the present invention, there is provided an alarm system comprising: an audio interface comprising: a microphone; a state sensor for sensing a state at the audio interface; a signal generator for generating an analog state signal indicative of the state; a combiner for forming a combined signal from an electrical signal corresponding to audio sensed at the microphone, and the state signal so that the state signal does not interfere with reproduction of audio from the electrical signal; a control panel for monitoring sensed conditions at the audio interface; a conductor interconnecting the audio interface to the control panel carrying the electrical and the state signal as combined from the audio interface to the control panel.

**[0009]** In accordance with an aspect of the present invention, there is provided a method of operating an alarm system comprising a control panel and an audio interface: sensing an audio signal at the audio interface; sensing a state at the audio interface panel, and generating an inaudible electric state signal in response thereto;

multiplexing the audio signal and the state signal to form a composite signal; and providing the composite signal to the control panel, for sensing the state at the control panel.

**[0010]** In accordance with an aspect of the present invention, there is provided an audio interface comprising: a microphone; a state sensor for sensing a state at the audio interface; a signal generator for generating an analog state signal indicative of the state; a combiner for forming a combined signal from an electrical signal corresponding to audio sensed at the microphone, and the state signal so that the state signal does not interfere with reproduction of audio from the electrical signal.

**[0011]** Conveniently, the state signal and audio signal may be carried on a single conductor, thereby reducing the number of physical interconnections between the control panel and audio interface.

**[0012]** Other aspects and features of the present invention will become apparent to those of ordinary skill in the art upon review of the following description of specific embodiments of the invention in conjunction with the accompanying figures.

#### BRIEF DESCRIPTION OF THE DRAWINGS

**[0013]** In the figures which illustrate by way of example only, embodiments of the present invention,

**[0014]** **FIG. 1** is a block diagram of a premises monitored by an alarm system and associated monitoring center, exemplary of an embodiment of the present invention;

**[0015]** **FIG. 2** is a block diagram of a control panel of the alarm system of **FIG. 1**;

**[0016]** **FIG. 3** is a schematic block diagram of a portion of an audio interface and control panel of the alarm system of **FIG. 1**; and

**[0017]** **FIG. 4** is a schematic diagram of a portion of the control panel of the alarm

system of **FIG. 1**.

#### DETAILED DESCRIPTION

**[0018]** **FIG. 1** illustrates premises **10**, monitored by an alarm system **40** exemplary of an embodiment of the present invention. As illustrated, alarm system **40** includes a central control panel **20**, in communication with a plurality of sensors **18**. Sensors **18** may be entry sensors, motion sensors, flood sensors, smoke sensors, gas sensors or any other sensors being monitored as appreciated by those of ordinary skill. Sensors **18** may be in communication with control panel **20**, wirelessly by wired interconnected 3-D electrical wiring premises **10** or otherwise.

**[0019]** Alarm system **40** further includes an audio interface **25**. Audio interface **25** may take the form of an audio station remote from panel **20**, and may include a microphone and may optionally further include a camera, keypad, display speaker, electronic ringer or the like.

**[0020]** Control panel **20** is interconnected with a communications network to a monitoring center **14**. In the depicted embodiment, control panel **20** is interconnected by a subscriber line **13** to the public switch telephone network "PSTN" **12**. Subscriber line **13** terminates in a central office (not shown) of PSTN **12**. A monitoring center **14** is also interconnected with PSTN **12**. Of course panel **20** could be interconnected with monitoring center **14** by way of another communications network, like a cellular telephone network, packet switched data network (e.g. the internet), or the like.

**[0021]** Monitoring center **14** is depicted as a single monitoring station. However, as is appreciated by those of ordinary skill, monitoring center **14** could be multiple monitoring stations, each in different physical locations. Monitoring center **14** is associated with one or more PSTN telephone numbers that would be used by telephone control panel **40** to contact monitoring center **14**.

**[0022]** As will become apparent, audio interface **25** allows two way audio communication between alarm system **10** and monitoring center **14**.

**[0023]** Sensors **18** and control panel **20** interact in a conventional manner. As particular sensor **18** is tripped, signifying a sensed condition, the sensor provides a signal to sensor interface **26** of control panel **20**. Control panel **20** initiates a communication to monitoring center **14**. For example, control panel **20** may place a telephone call to a pre-programmed telephone number to contact monitoring center **14**, typically by way of PSTN **12**.

**[0024]** Control panel **20** is more particularly illustrated in **FIG. 2**. As illustrated, control panel **20** includes a central processor **32** in communication with memory **30**. Input/output interface **24**, sensor interface **26**, and network interface **28**. In the depicted embodiment, network interface **28** is interconnected through PSTN subscriber line **13**.

**[0025]** Input/output interface **24** may communicate with audio interface **25** (**FIG.1**), and may bridge audio signals from and to audio station over network interface **28**. In the depicted embodiment, audio interface **25** allows two-way full-duplex audio communication between control panel **20** and audio interface **25**. As such, audio interface **25** is interconnected to control panel **20** by at least two conductors **27a**, **27b** (typically in the form of wires). The two conductors **27a**, **27b** are used to carry audio signals from and to audio interface **25** to control panel **20**. As will become apparent, the audio signals may be bridged to monitoring center **14** so that sound at premises **10** may be monitored during alarm condition or otherwise at monitoring center **14**. Likewise center **14** may originate a signal to be heard at audio interface **25**.

**[0026]** A further block diagram of portion of audio interface **25** and input output interface **24** is depicted in **FIG. 3**. As illustrated, audio interface **25** includes a speaker **50**, one or more amplifiers **52**, a microphone **54**, a microphone preamplifier **56**, a signal generator **58**, a state sensor **60**, an optional signal conditioner **62** and a mixer/multiplexer **64**.

[0027] Signal generator **58** generates an analog signal. Signal generator **58** may be a low frequency oscillator, which may for example generate a square wave or other wave form. Signal conditioner **62** may further condition the signal generated by signal generator **58**. For example, if signal generator **58** generates a square wave, conditioner **62** may be a filter to generate a sine wave, or a saw tooth wave.

[0028] Mixer/multiplexer **64** may be an analog multiplexer or mixer that be capable of mixing two analog input signal. Mixer/multiplexer **64** may be a summer formed of passive components, or a sampling amplifier, or may take the form of a signal modulator or the like, or may be any other suitable signal combiner.

[0029] Microphone **54** may sense a signal in the audible range at audio interface **25**. For example, microphone **54** may sense audio signals in the frequency range of **200-2000Hz**. Of course, a broader frequency range signals could be sensed by microphone **54**. The audio signal may be amplified by microphone pre-amplifier **56**.

[0030] Conductors **27a**, **27b** act as speaker and microphone wires to panel **20**, respectively.

[0031] At panel **20**, microphone conductor **27b** feeds a filter **82** of input/output interface **24**. Filter **82** is a low pass filter, and acts as a detector that detects a low frequency signal on conductor **27b**. Filter **82** provides an output to a signal conditioner **84** in communication with a debounce filter **86** to provide digital signal output to processor **32** (FIG. 2).

[0032] Debounce filter **86** filters noise and transients that may interfere with a few cycles of the state signal, so that a digital tamper indication is not presented to the processor **30** prematurely. Electrostatic discharge at the audio station or a surge pulse induced into the conductor **27b** are examples of noise signals that may be filtered by debounce filter **86**.

[0033] Microphone conductor **27b** similarly feeds one or more audio amplifiers **88** and buffers that, in turn, amplify any audible signal on conductor **27b** to provide an audio signal that may be passed to network interface **28**.



[0034] Likewise an audio signal from network interface **28** may be passed to conductor **27a** for provision to audio interface **25**.

[0035] Power may be provided to audio interface **25** by power supply conductors **29**. These may originate at panel **20**, or elsewhere, such as at a battery, AC adapter or the like. Conveniently, one of conductors **29** may provide a common ground between panel **20** and audio interface **25**.

[0036] At panel **20**, as illustrated in **FIG. 4**, filter **82** forms a hi-pass filter with a 3dB point near 250Hz to allow the audio signal from microphone **54** to be passed to the audio section of panel **20** and blocks the subsonic signal. Transistor **90** is used to shut down the microphone input when required. The subsonic and audio signals are presented to the lo-pass filter **84** which has a 3dB roll-off at near 30Hz. This allows the subsonic signal to be passed to the signal conditioner **85** then debounce filter **86**, while attenuating the audio signals.

[0037] In operation, signal generator **58** generates an inaudible signal, indicative of a sensed state at audio interface **25**. In the depicted embodiment, the oscillator generates a subsonic (or near subsonic) signal, for example having a frequency of less than **50 Hz** (e.g. **25** or **20 Hz** or less). As noted, this signal may be conditioned by signal conditioner **62**, and provided to modulator/mixer **64**. This low frequency state signal is carried by microphone conductor **27b**. As required, the low frequency signal may be amplified in order to provide a desired signal strength at panel **20**.

[0038] The sensed state may be an indication of whether or not audio interface is powered, whether it has been tampered with, or any other sensed condition, sensed at audio interface **25**.

[0039] Audio interface **25** may be activated by user interaction at audio interface **25** (e.g. by way of button press, or the like), or by panel **20** in the presence of a sensed condition (e.g. a tripped entry sensor, fire, or the like).

[0040] In any event, once audio interface **25** is activated, an audio signal detected by microphone **54** may also be provided to multiplexer/mixer **64**. Multiplexer/mixer **64**

combines an electrical signal corresponding to audio sensed at the microphone from microphone **54** and the state signal from signal generator **58** to form a combined signal. As will become apparent, the state signal does not interfere with reproduction of audio from the electrical signal once extracted from the combined signal.

**[0041]** Thus, microphone conductor **27b** carries the combined signal including both the audio signal and the state signal generated by signal generator **58**.

**[0042]** Input/output interface **24** demultiplexes the audio and state signals on conductor **27b**. Specifically hi-pass filter **82**, low-pass filter **84** and signal conditioner **85** act as the de-multiplexer for the complex signal of different frequencies. Low-pass filter **84** allows any subsonic signal on conductor **27b** to pass and feed signal conditioner **85** to create a digital signal that signals the presence or absence of the state signal on conductor **27b**. This digital signal is applied to debounce filter **86** which filters transients, and thereby delays the application of a sudden change in the digital signal to the processor due, for example, to missing subsonic pulses on conductor **27b** caused by electrostatic discharge at audio station **25** or the like.

**[0043]** Of course, if the state signal and audio signal were otherwise multiplexed (e.g. frequency modulated, phase modulated, or the like), input/output interface **24** could be perform complimentary demultiplexing to detect the state signal.

**[0044]** Now, state sensor **60**, in the form of a switch is interconnected with low signal generator **58**. In the presence of a tamper condition, switch forming state sensor **60** is opened and the state signal is no longer generated by signal generator **58** or provided to microphone conductor **27b**. Tamper switch forming state sensor **60** may, for example, be physically interconnected with the panel **20**. The tamper switch may, for example, be a leaf switch, or contact switch used to sense the integrity of a housing, housing audio interface **25**. The tamper switch may alternatively be a leaf switch or similar switch used to sense that audio panel **25** remains mounted. Alternatively, a mercury switch or other tamper sensor could be used as state sensor **60**. As will be appreciated, although only a single tamper switch is depicted, multiple tamper switches or sensors could form part of audio panel **25** to form state sensor

**60.** The multiple switches could be connected in series or to multiple inputs of signal generator **58**. A person of ordinary skill will readily appreciate multiple possible tamper detection arrangements that may be used as tamper switch **60**, to detect unauthorized access, manipulation, disconnection or other tampering with audio interface **25**. Alternatively, the tamper switch could be replaced with some other state sensor at audio interface **25**. For example, a photo detector, moisture sensor, or the like could be used in place of a switch.

**[0045]** At panel **20**, the absence of the state signal (e.g. the low frequency subsonic signal) may indicate a sensed state – such as a tamper condition, which may in turn, be signaled by control panel **20** by way of PSTN **12** to monitoring center **14**. Additionally, a local alarm at premises **10** could be signalled. For example a siren may sound, or another audible or visual indicator could be signalled by panel **20**.

**[0046]** Conveniently, disconnecting power from audio interface **25** may likewise cause signal generator **58** to cease providing the low frequency tamper signal, indicating a tamper with audio panel **25**.

**[0047]** At the same time, audio signals from monitoring center **14** may be passed to audio interface **25** by network interface **28** over conductor **27a**, allowing full duplex communication with monitoring center **14**. Alternatively, half duplex communication could be permitted over a single conductor.

**[0048]** As will now be appreciated, by multiplexing both an audio signal and a low frequency (sub-audio) tamper, it may be possible to carry both audio and state signals using only one signal conductor (e.g. microphone conductor **27b**). Conveniently, the state signal may be inaudible at panel **20** (and hence monitoring center **14**), and need not interfere with audio monitoring at audio interface **25**. Both audio and state signals are analog signals.

**[0049]** As will further be appreciated, although only a single audio interface **25** has been depicted, panel **20** may communicate with multiple such audio interfaces like

audio interface **25**, at different locations in premises **10**, as suggested by **FIG. 2**.

**[0050]** In an alternate embodiment, a supersonic signal (e.g. a signal in a frequency range higher than about 15,000 Hz) could be used as a state signal. Of course, suitable filters could be used at audio interface **25** to sense the presence or absence of a supersonic state signal.

**[0051]** In a further alternate embodiment, the state signal could be used to modulate the bias of microphone **54**. For example, the output of microphone **54** could be biased at a specific voltage level. The AC audio signal from the microphone would be AC coupled on the bias voltage and the tamper switch **60** would control the bias level. The bias level could be detected at panel **20** and if the bias level were inside a specific voltage window, no tamper condition could be sensed. Likewise if the bias level were outside the voltage window, a tamper condition/state could be detected. The bias level could be measured by an analog to digital converter at interface **24**, and the voltage window limits could be assessed by processor **30** under software control.

**[0052]** Likewise, the state signal could be a frequency or phase modulated signal modulated onto the audio signal. The frequency could be detected using a frequency discriminator to determine the presence or absence of the tamper at the audio station. A phase modulated signal could likewise be detected using a phase detector.

**[0053]** Of course, the above-described embodiments are intended to be illustrative only and in no way limiting. The described embodiments of carrying out the invention, are susceptible to many modifications of form, arrangement of parts, details and order of operation. The invention, rather, is intended to encompass all such modification within its scope, as defined by the claims.

## WHAT IS CLAIMED IS:

## 1. An alarm system comprising:

an audio interface comprising:

a microphone;

a state sensor for sensing a state at said audio interface;

a signal generator for generating an analog state signal indicative of said state;

a combiner for forming a combined signal from an electrical signal corresponding to audio sensed at said microphone, and said state signal so that said state signal does not interfere with reproduction of audio from said electrical signal;

a control panel for monitoring sensed conditions at said audio interface;

a conductor interconnecting said audio interface to said control panel carrying said electrical and said state signal as combined from said audio interface to said control panel.

2. The alarm system of claim 1, wherein said state sensor comprises a tamper switch for sensing tampering with said audio interface.
3. The alarm system of claim 1, wherein said signal generator comprises a low frequency oscillator producing a frequency below the frequency of audible sound.
4. The alarm system of claim 3, wherein said low frequency oscillator generates a signal having a frequency less than **50** Hz.
5. The alarm system of claim 1, wherein said low frequency oscillator generates a signal having a frequency less than **25** Hz.

6. The alarm system of claim 1, wherein said combiner comprises an analog multiplexer.
7. The alarm system of claim 1, further comprising two power conductors, for providing electrical power to said audio interface.
8. The alarm system of claim 7, wherein said two power conductors interconnect said control panel to said audio interface.
9. The alarm system of claim 1, wherein absence of said inaudible state signal on said conductor indicates an alarm condition to said paid control panel.
10. The alarm system of claim 1, wherein said signal generator comprises a oscillator producing a frequency above the frequency of audible sound.
11. The alarm system of claim 1, wherein said combiner comprises a summing amplifier.
12. A method of operating an alarm system comprising a control panel and an audio interface:
  - sensing an audio signal at said audio interface;
  - sensing a state at said audio interface panel, and generating an analog electric state signal in response thereto;
  - multiplexing said audio signal and said state signal to form a composite signal;
  - and
  - providing said composite signal to said control panel, for sensing said state at said control panel.
13. The method of claim 12, wherein said sensing a state comprises sensing tampering with said audio interface.
14. The method of claim 12, wherein said multiplexing comprises summing said audio

signal and said state signal on a single conductor.

15. The method of claim **12**, wherein said inaudible electric state signal has a frequency of less than **50** Hz.

16. An audio interface comprising:

a microphone;

a state sensor for sensing a state at said audio interface;

a signal generator for generating an analog state signal indicative of said state;

a combiner for forming a combined signal from an electrical signal corresponding to audio sensed at said microphone, and said state signal so that said state signal does not interfere with reproduction of audio from said electrical signal.

1/4

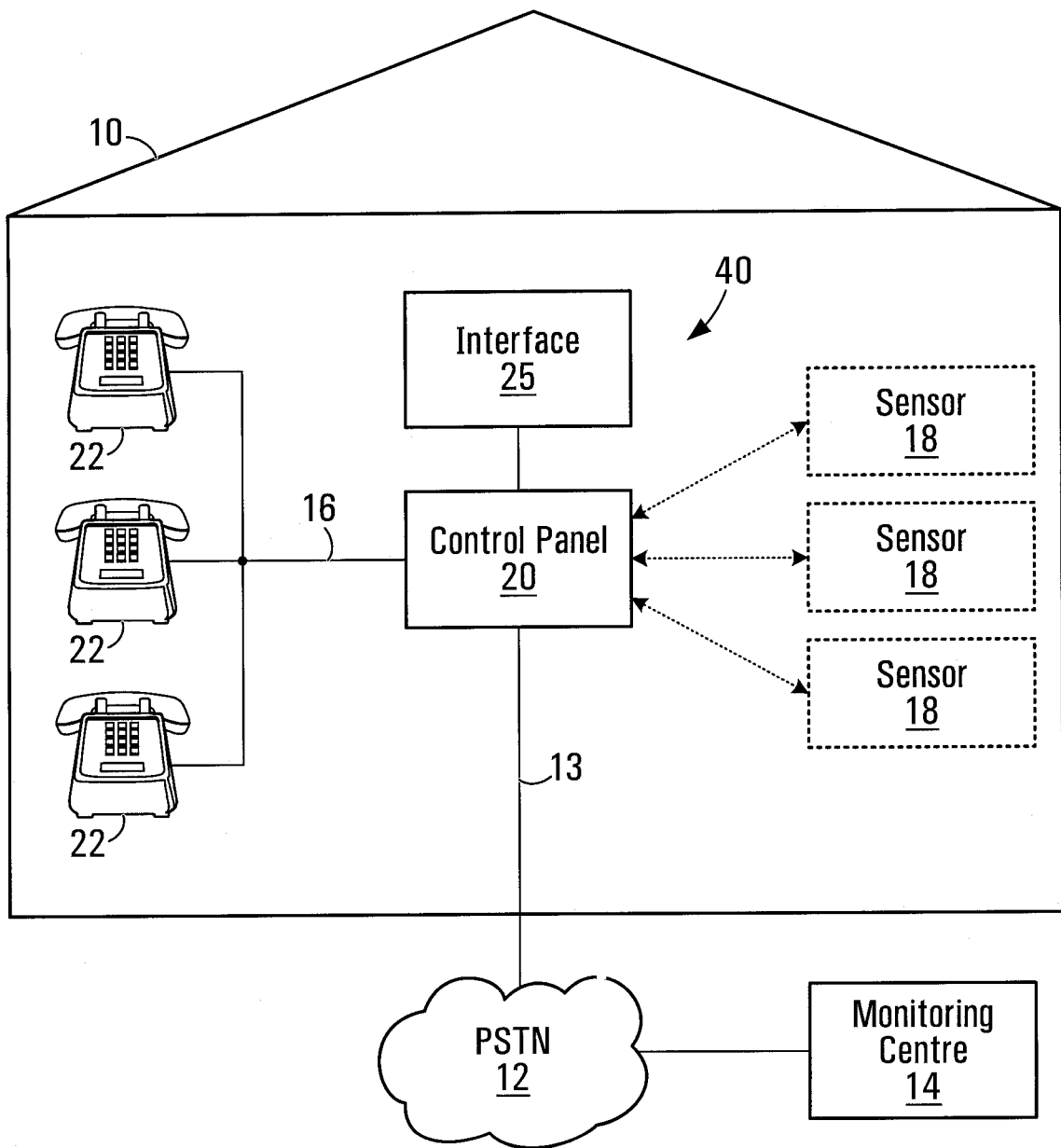

FIG. 1



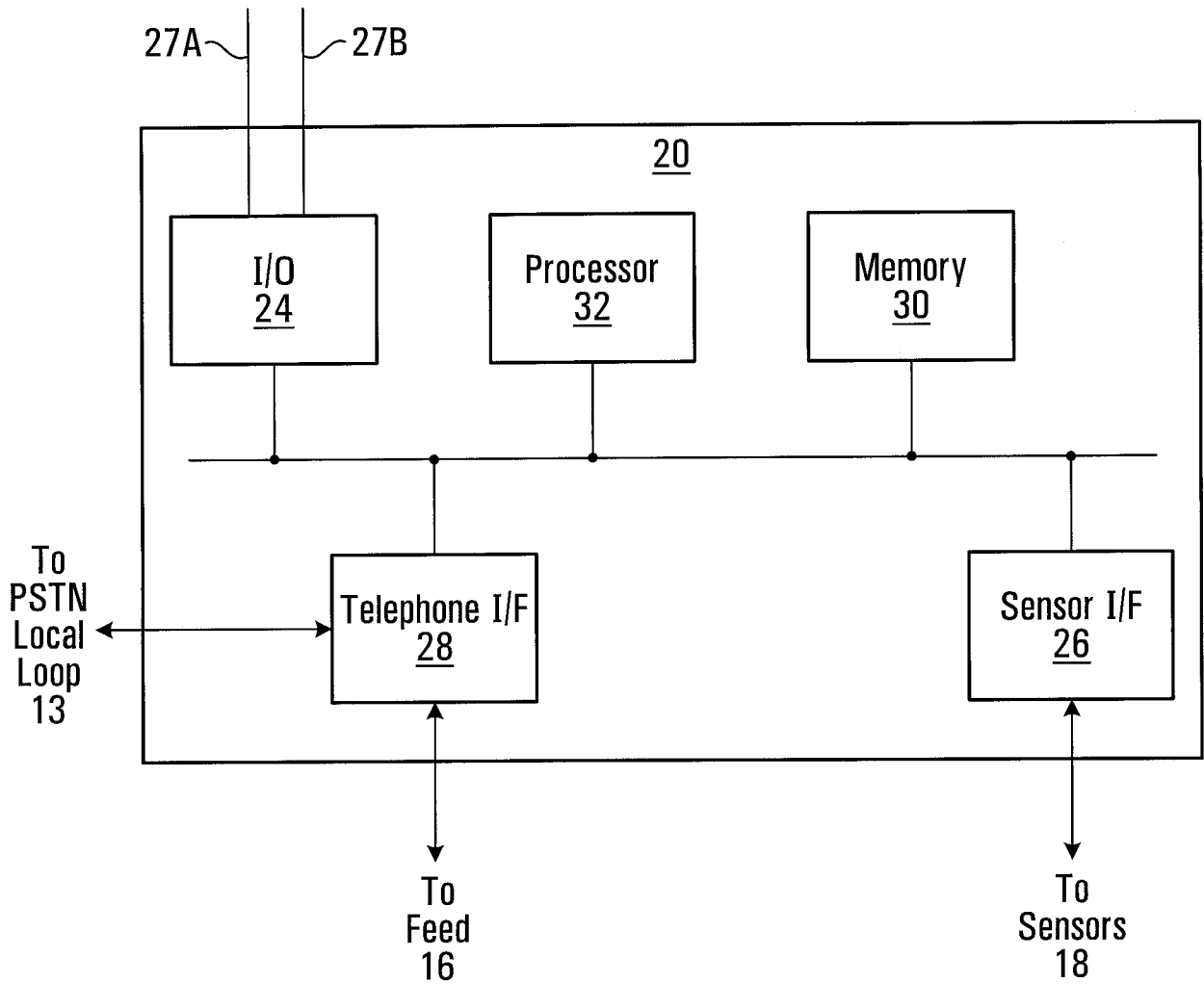

FIG. 2

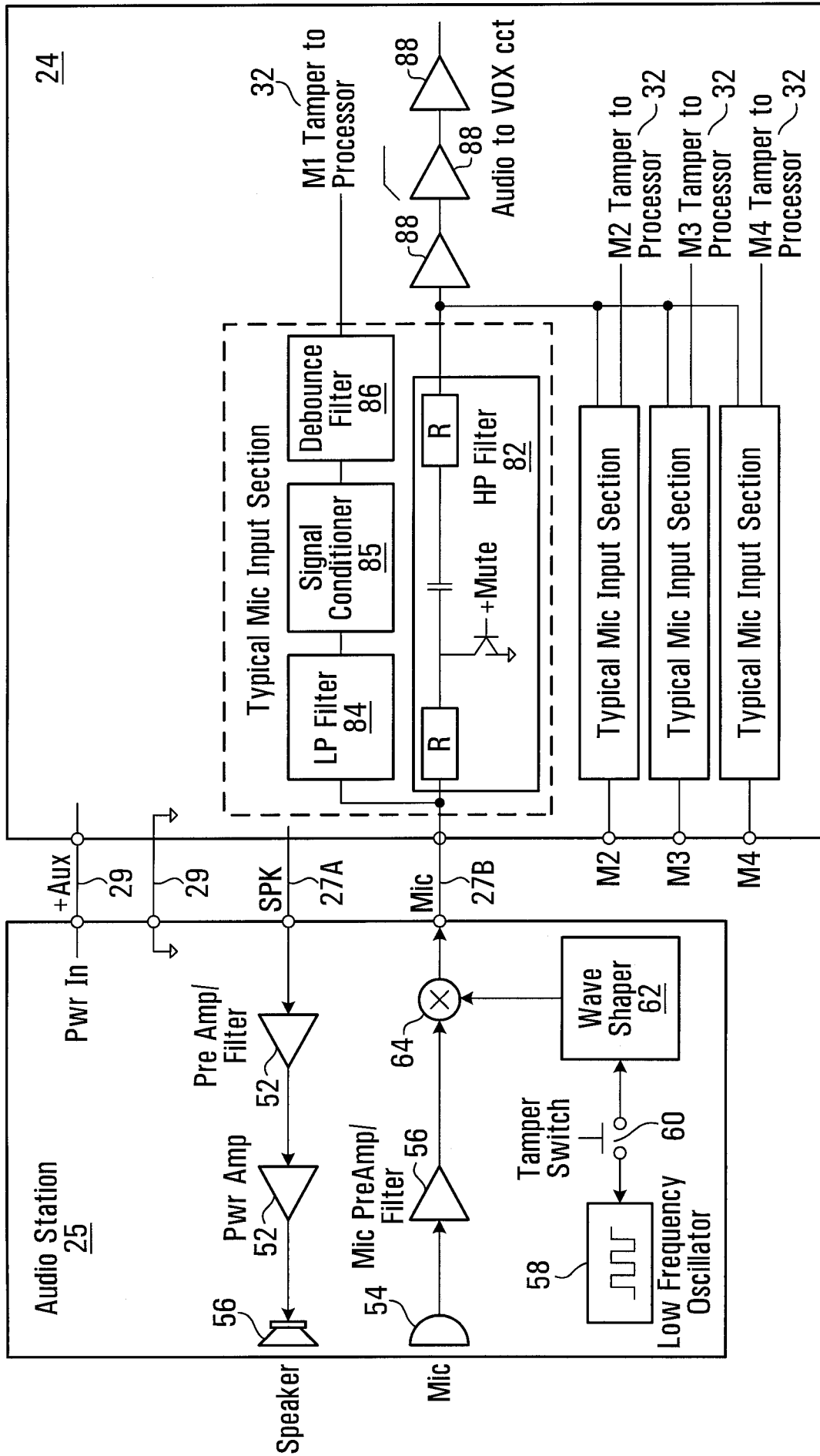

FIG. 3

4/4

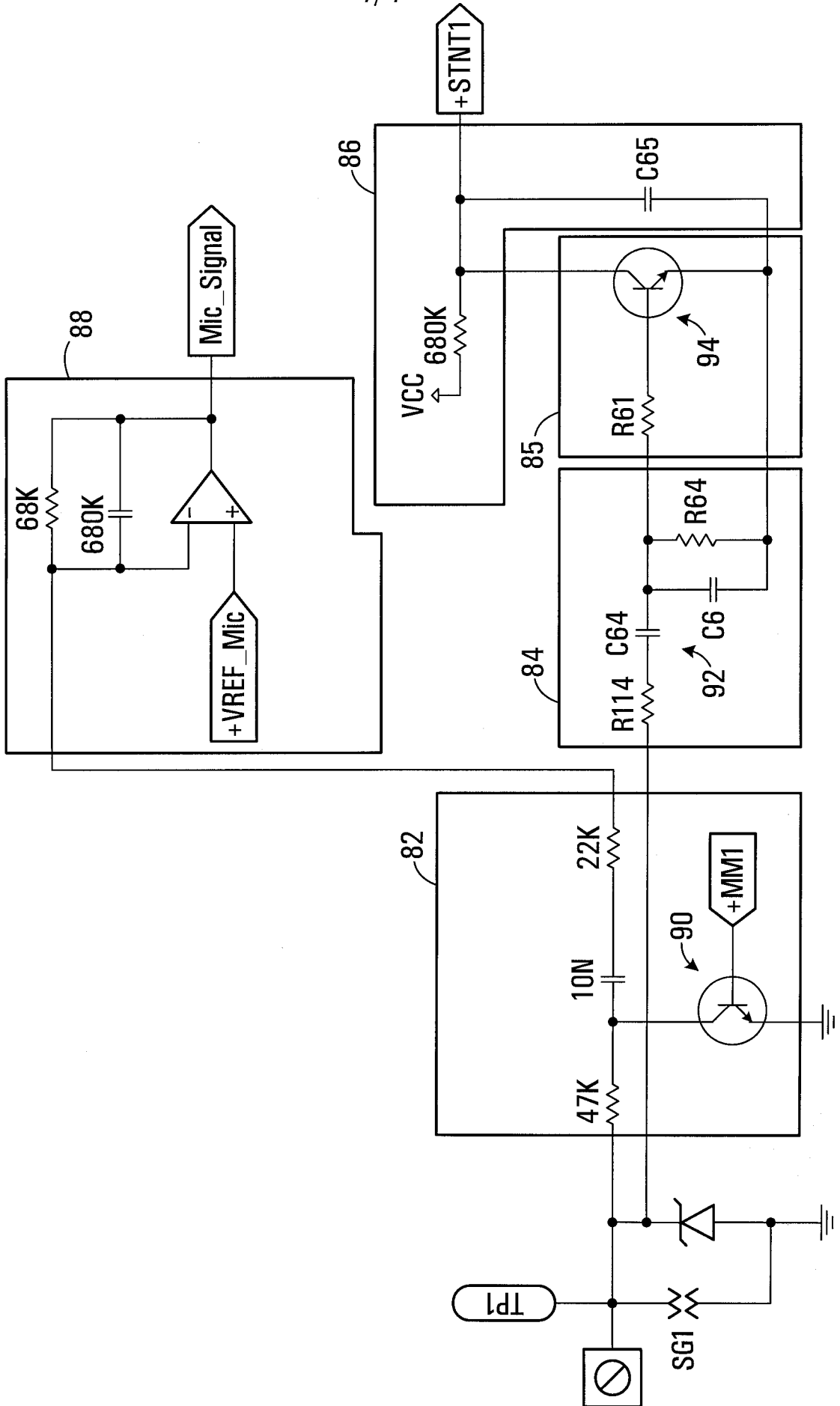

FIG. 4

**INTERNATIONAL SEARCH REPORT**

International application No.  
PCT/CA2008/002046

<p>A. CLASSIFICATION OF SUBJECT MATTER  <b>IPC: G08B 23/00 (2006.01) , G08B 29/00 (2006.01) , H04R 3/00 (2006.01) , H04R 3/02 (2006.01)</b>                  According to International Patent Classification (IPC) or to both national classification and IPC</p>		
<p>B. FIELDS SEARCHED</p>		
<p>Minimum documentation searched (classification system followed by classification symbols)                  IPC (2006.01): G08B, H04R</p>		
<p>Documentation searched other than minimum documentation to the extent that such documents are included in the fields searched</p>		
<p>Electronic database(s) consulted during the international search (name of database(s) and, where practicable, search terms used)                  Delphion, US Patent Office Database (WEST), Canadian Patent Office Database, World Wide Web, Espacenet.                  Keywords: audio, alarm, state, sens*, combin*, multiplex, electric*, signal, interface, control*.</p>		
<p>C. DOCUMENTS CONSIDERED TO BE RELEVANT</p>		
<b>Category*</b>	<b>Citation of document, with indication, where appropriate, of the relevant passages</b>	<b>Relevant to claim No.</b>
X	WO 2007/030190 A1 (Stern et al.), 15 March 2007 (15-03-2007) *See Abstract, Figures 1-4, Page 5 lines 3-30	16
A	WO 2007/032971 A2 (Prince et al.), 22 March 2007 (22-3-2007) *See whole document	1-15
A	US 2005/0276423 A1 (Aubauer et al.), 15 December 2005 (15-12-2005) *See whole document	1, 12, 16
A	US 7 277 849 B2 (Streich et al.), 02 October 2007 (02-10-2007) *See Abstract, Figure 2, Column 2 line 39 - Column 3 line 31	1-15
A	US 2003/0096607 A1 (Taylor), 22 May 2003 (22-05-2003) *See whole document	1, 12
<p><input checked="" type="checkbox"/> Further documents are listed in the continuation of Box C.                      <input checked="" type="checkbox"/> See patent family annex.</p>		
<b>*</b>	Special categories of cited documents :	<b>"T"</b> later document published after the international filing date or priority date and not in conflict with the application but cited to understand the principle or theory underlying the invention
<b>"A"</b>	document defining the general state of the art which is not considered to be of particular relevance	<b>"X"</b> document of particular relevance; the claimed invention cannot be considered novel or cannot be considered to involve an inventive step when the document is taken alone
<b>"E"</b>	earlier application or patent but published on or after the international filing date	<b>"Y"</b> document of particular relevance; the claimed invention cannot be considered to involve an inventive step when the document is combined with one or more other such documents, such combination being obvious to a person skilled in the art
<b>"L"</b>	document which may throw doubts on priority claim(s) or which is cited to establish the publication date of another citation or other special reason (as specified)	<b>"&amp;"</b> document member of the same patent family
<b>"O"</b>	document referring to an oral disclosure, use, exhibition or other means	
<b>"P"</b>	document published prior to the international filing date but later than the priority date claimed	
<p>Date of the actual completion of the international search 2 March 2009 (02-03-2009)</p>		<p>Date of mailing of the international search report 5 March 2009 (05-03-2009)</p>
<p>Name and mailing address of the ISA/CA                  Canadian Intellectual Property Office                  Place du Portage I, C114 - 1st Floor, Box PCT                  50 Victoria Street                  Gatineau, Quebec K1A 0C9                  Facsimile No.: 001-819-953-2476</p>		<p>Authorized officer   <b>Sajith Bandaranayake 819- 934-6754</b></p>

**INTERNATIONAL SEARCH REPORT**International application No.  
PCT/CA2008/002046

C (Continuation). DOCUMENTS CONSIDERED TO BE RELEVANT		
Category*	Citation of document, with indication, where appropriate, of the relevant passages	Relevant to claim No.
A	EP 0 683 592 B1 (Cohen), 26 July 2000 (26-07-2000) *See Paragraphs [0008], [0014] - [0018], Claims 1-18	1-16
A	US 4 218 763 (Kelley et al.), 19 August 1980 (19-08-1980) *See Abstract, Figures 1-4, Column 3 line 33 - Column 4 line 14	1-15

**INTERNATIONAL SEARCH REPORT**  
Information on patent family members

International application No.  
PCT/CA2008/002046

Patent Document Cited in Search Report	Publication Date	Patent Family Member(s)	Publication Date
WO 2007030190A1	15-03-2007	GB 0518213D0	19-10-2005
		GB 2430129A	14-03-2007
		GB 2430129B	31-10-2007
WO 2007032971A2	22-03-2007	US 2007057778A1	15-03-2007
		WO 2007032971A3	22-11-2007
US 2005276423A1	15-12-2005	AU 4284600A	09-10-2000
		CA 2367579A1	28-09-2000
		DE 19934724A1	19-04-2001
		EP 1161852A2	12-12-2001
		JP 2002540696T	26-11-2002
		WO 0057671A2	28-09-2000
		WO 0057671A3	15-03-2001
		US 7277849B2	02-10-2007
US 2003096607A1	22-05-2003	CN 1266673C	26-07-2006
		CN 1623185A	01-06-2005
		DE 60214599D1	19-10-2006
		DE 60214599T2	13-09-2007
		EP 1483759A1	08-12-2004
		EP 1483759B1	06-09-2006
		US 2003220783A1	27-11-2003
		WO 03077235A1	18-09-2003
		US 7006799B2	28-02-2006
		US 7065323B2	20-06-2006
US 7113073B2	26-09-2006		
US 7248836B2	24-07-2007		
US 7289764B2	30-10-2007		
US 7346331B2	18-03-2008		
US 2003074936A1	24-04-2003		
US 2003098777A1	29-05-2003		
US 2003098778A1	29-05-2003		
US 2003098779A1	29-05-2003		
US 2003098780A1	29-05-2003		
US 2003100266A1	29-05-2003		
US 2003103472A1	05-06-2003		
US 2003117263A1	26-06-2003		
US 2003143956A1	31-07-2003		
US 2004261478A1	30-12-2004		
EP 0683592B1	26-07-2000	CA 2148743A1	10-11-1995
		DE 69518111D1	31-08-2000
		DE 69518111T2	22-03-2001
		EP 0683592B1	26-07-2000
		EP 0969650A1	05-01-2000
		ES 2152341T3	01-02-2001
		IL 109601A	14-05-1996
		IL 109601D0	26-08-1994
		US 5812054A	22-09-1998
		US 6094134A	25-07-2000
		US 4218763A	19-08-1980