

*H. P. Appleton,*

*Reversible Latch.*

*No. 107,587.*

*Patented Sept. 20, 1870.*

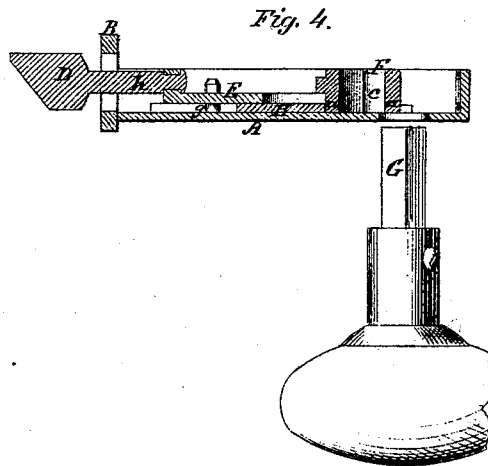
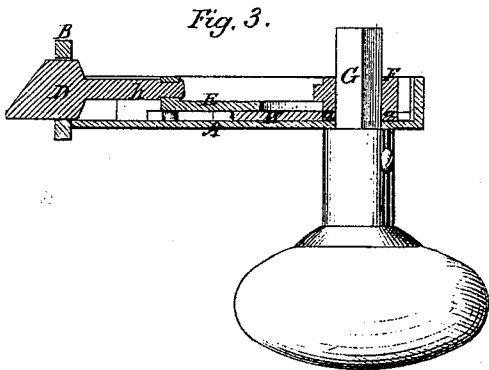
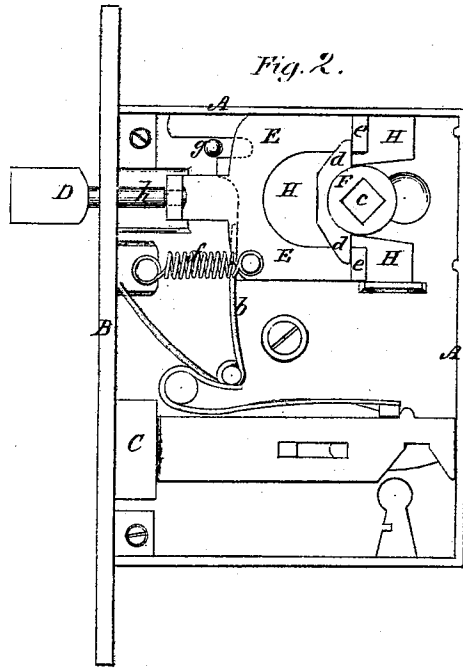
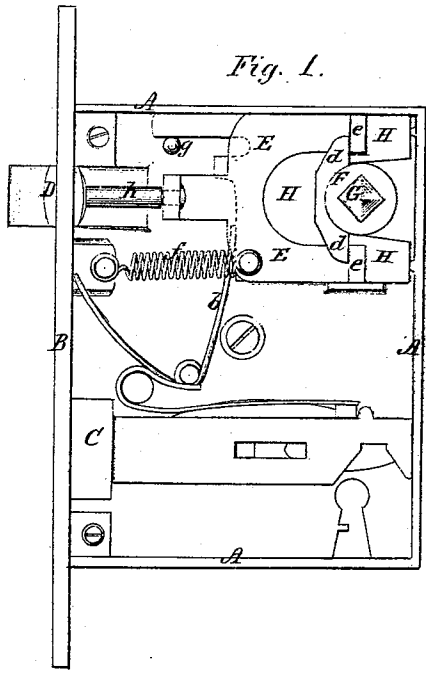

*Witnesses.*

*W. Hamilton Johnson*  
*Chas. C. Wepferman*

*Henry P. Appleton, Inventor.*

*By his Attorneys*  
*Wepferman & Johnson.*

# UNITED STATES PATENT OFFICE.

HENRY P. APPLETON, OF NORWICH, CONNECTICUT, ASSIGNOR TO WILLIAM  
A. AIKEN, OF SAME PLACE.

## IMPROVEMENT IN REVERSIBLE KNOB-LATCHES.

Specification forming part of Letters Patent No. 107,587, dated September 20, 1870.

*To all whom it may concern:*

Be it known that I, HENRY P. APPLETON, of Norwich, in the county of New London and State of Connecticut, have invented a new and useful Improvement in Reversible Latch-Locks; and I do hereby declare that the following is a full, clear, and exact description thereof, reference being had to the accompanying drawings of the same, which make part of this specification, in which—

Figure 1 represents the interior of a mortise reversible latch-lock embracing my improvements. Fig. 2 represents a similar view, the parts being in the positions they occupy when the latch-bolt is withdrawn for reversion. Fig. 3 represents a section through the latch-bolt, the parts corresponding to those shown in Fig. 1. Fig. 4 represents a similar section, the parts occupying the position shown in Fig. 2.

In the accompanying drawings, A represents the case, B the face-plate, C the bolt, D the reversible latch with its fork or yoke E, F the armed hub, and G the spindle, of a reversible latch-lock. These parts may be constructed and arranged as represented in the drawings, or in any other suitable manner, and, as my improvement relates only to a device in connection with the reversible latch, a further description of these parts is deemed unnecessary. The latch is of that character which requires only to be withdrawn by the thumb and finger, so as to bring its beveled head without the opening in the face-plate, to reverse its bevel, to adapt it to a right or left hand door, and in doing this it is necessary to remove the spindle from the hub and again insert it after the reversion of the latch. In order that this may be done quickly and conveniently, the armed hub or cam F is provided with an adjustable or sliding bearing-plate, H, forked so as to embrace the neck *a* of the hub, and placed either above or beneath the fork or yoke E of the latch, so that it will bear against said hub and constantly tend, by the pressure of a spring, *b*, to return the hub after the reversion of the latch, to a position that will bring its opening *c* directly opposite those in the lock-plates, and, in addition, keep its arms or cams *d* in close contact with the raised ends or projections *e* of the latch-yoke. The return movement of this bearing-plate H is limited by its contact with a stop, which may be the inner rear side of

the lock-case, as shown in Fig. 1. The latch-yoke E is connected to the case A by a spring, *f*, which constantly tends to throw out the bolt to its proper place after its withdrawal by the cam or knob; and the sliding bearing H is constantly forced in by its spring *b*, connected to the lock-plate, and bearing against its front end. The force of this last-named spring *b*, however, must be greater than that of the latch-spring *f*, in order to keep the bearing-plate properly in place against its stop, and to counteract the tendency of the latch-spring to pull it out. The front end of the sliding bearing-plate is guided by a pin, *g*, in the lock-case. The withdrawal of the bolt for reversion is therefore effected against the force of the spring *b*, while the latch-spring assists in such withdrawal. The tail or shank *h* of the latch-bolt D is swiveled in the end of its forked plate, and the latter is held in place by suitable guiding-projections. The hub is maintained in its proper position and connection with the bearing-plate E by the cover of the lock, and, as its ends do not project into the spindle-openings of the lock-plates, it is free to slide with the bearing-plate and latch-yoke in withdrawing the latch.

The bearing-plate H may be of any suitable metal or substance capable of being cast, stamped out, or otherwise wrought, and of any form or shape to suit the varied shapes of different lock-cases.

In the drawings I have represented my improvement as applied to a "mortise-lock;" but it is obvious that it is equally applicable to a "rim-lock" and to yoke latch-plates having varied constructions.

When the bearing-plate is placed above the latch-plate, its front end may be bent over the said yoke, so as to form a bearing for the end of its returning-spring.

Having described my invention, I claim—

The single sliding or adjustable bearing-plate H, arranged to support and carry the armed hub F, in combination with yoke E, spring *b*, and reversible latch D, all constructed substantially as and for the purpose described.

In testimony whereof I have hereunto set my hand.

HENRY P. APPLETON.

Witnesses:

H. P. FAIRFIELD,  
GEO. D. LEWIS.