

Dec. 25, 1923.

1,478,370

W. T. ADOLPHSEN

BURNER NOZZLE

Filed March 25, 1922

FIG. 1.

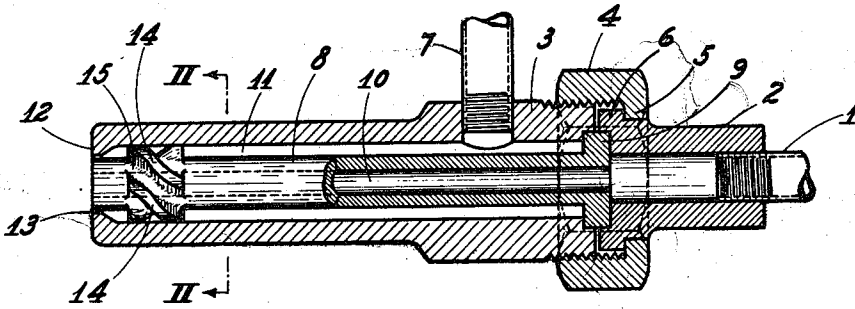

FIG. 2.

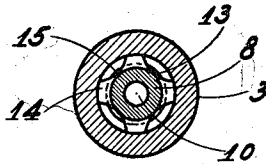
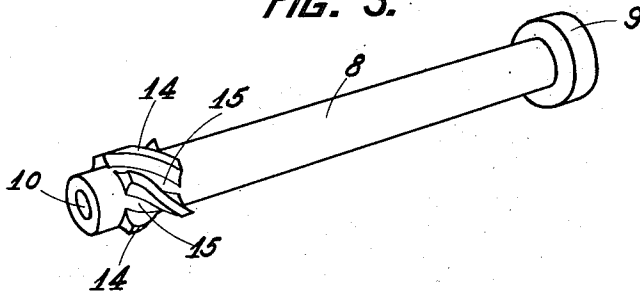

FIG. 3.



WITNESSES
A. B. Wallace

Jo. Bailey Brown

William T. Adolphsen
INVENTOR

by Winter & Brown
ATTORNEYS

UNITED STATES PATENT OFFICE.

WILLIAM T. ADOLPHESEN, OF VERONA, PENNSYLVANIA.

BURNER NOZZLE.

Application filed March 25, 1922. Serial No. 546,929.

To all whom it may concern:

Be it known that I, WILLIAM T. ADOLPHESEN, a citizen of the Republic of Chile, and a resident of Verona, in the county of Allegheny and State of Pennsylvania, have invented a new and useful Improvement in Burner Nozzles, of which the following is a specification.

This invention relates to nozzles for liquid fuel burners.

The object of the invention is to provide a burner of an improved construction, adapted to atomize liquid fuels such as heavy crude oils and to discharge them into a combustion chamber in the form of a thoroughly broken up readily combustible fog-like mist or spray.

This object, and others, including a simple, easily manufactured durable construction, are attained by the arrangement of parts illustrated in the drawings and set forth in the following specification.

Referring to the drawings Fig. 1 is a central vertical partial section through the nozzle and its connecting pipes, constituting the burner; Fig. 2 is a vertical cross section on the line II—II of Fig. 1; and Fig. 3 is a perspective view of the central member of the burner.

In burning such heavy fuels as crude oil, tar and the like, it is necessary to break up the heavy hydro-carbon liquid into small globules or particles, and to mix these with an oxygen burning gas, and to introduce these into a heated chamber, in order to secure a ready combustion of such fuels.

It has been customary, and is the common practice, to discharge such fuels into the furnace through a burner by means of a gas such as air or steam, which passes through the burner and picks up the fuel at some point therein, in such manner as to atomize the liquid fuel as it is discharged into the furnace.

My invention employs this old and well known principle, and the improvement lies in the change of construction and arrangement of parts, whereby the gas is caused to form a vortex at the end of a burner supply pipe in such a manner as to draw the fuel from the pipe and effectively atomize it. Particularly, my arrangement secures the discharge of the carrying gaseous fluid, such as air or steam, from a narrow annular opening surrounding an outlet at the tip of the burner from which the liquid fuel

emerges unmixed with said gaseous fluid. In addition to discharging the carrying gas from such a narrow circular opening surrounding the fuel outlet, I provide means so that this gas emerges with a centrifugal, or whirling action forming a vortex, and it is this arrangement that draws the liquid from the pipe and secures the very efficient atomizing of the fuel, and consequently the more ready and complete combustion thereof in the furnace.

Referring to Fig. 1 of the drawings the burner, or nozzle, is attached to a fuel supply pipe 1 by a connecting member 2 of standard form, which is attached to the nozzle casing 3 by a standard union construction comprising an internally threaded member 4 having an internal flange 5 adapted to engage an external flange 6 on the union member 2. When the member 4 is turned down on the threaded end of the casing 3 the flange 5 draws the flange 6 inward towards the end of the casing 3, as is obvious. This is a well known pipe union arrangement.

A supply pipe 7 is threaded laterally into the casing 3 and is adapted to supply gaseous fluid under pressure, as will be more fully described below.

Centrally positioned inside the casing 3 is a cylindrical core member 8, having an exterior flange 9 at its rear end. This flange is adapted to seat in an annular cut-out portion at the base of the casing 3, and is clamped therein by contact of the union member 2, which has a corresponding cut-out portion at its forward end adapted to fit over the flange 9, all as clearly illustrated in Fig. 1. Consequently, when the outer sleeve member 4 of the union is turned down, the flange 9 of the central member 8 is clamped between the base of the sleeve 3 and the forward end of the member 2, and held rigidly in position.

The central member 8 has an axial bore 10 extending therethrough. This bore connects with the central bore through the member 2 and consequently with the supply pipe 1, and at its forward end opens at the top of the burner or nozzle.

The central opening in the sleeve member 3 is slightly larger than the exterior diameter of the core member 8, so that there is a circular passage or chamber 11, surrounding the central member 8 and extending to the tip of the burner. This chamber is en-

tirely closed at the rear of the burner by the clamping of the flange 9 against the base of the casing 3, as will be obvious. At the forward end of the burner the casing member 3 has its central bore restricted by a tapered shoulder 12, which extends inward uniformly, leaving only a very slight circular passage 13 surrounding the tip of the central core member 8, as clearly illustrated in Figs. 1 and 2.

Near the forward end of the burner, and just inside the shoulder 12, the core member 8 has a series of spirally arranged threads or flanges 14 on its periphery, and extending outward to contact with the inner wall of the casing 3. Ordinarily these flanges are made by leaving a collar on the exterior wall of the core member 8, and then cutting out spiral channels in this collar. But the method of formation of the raised spiral flanges 14 is unimportant and they may be provided by a separate member or otherwise, as will be evident. The essential thing is to have spiral passages 15 formed in the chamber 11. It will be observed that these flanges 14 are situated a short distance behind the restricting annular collar 12, and the annular outlet opening 13, at the tip of the burner or nozzle. While the pitch of these flanges, their extents, and the space between their ends and the outer end of the burner may vary in burners of different sizes and for different uses, the relative proportions are preferably preserved substantially as shown in the drawings.

The operation of this device is as follows:

It will be understood that the pipe 1 leads to some source of fuel supply, as for example an oil tank positioned slightly above the burner, whereby to provide a head of oil sufficient to cause it to flow through the pipe 4 and bore 10 of the burner core. Suitable valves and pressure mechanism will be provided so that the flow of fuel can be accurately regulated, and turned off and on as desired.

The pipe 7 is preferably connected to a compressed air tank, and also to a steam boiler, by some sort of two-way valve, so that air may be supplied through the pipe 7 when the furnace is first fired, and the burner caused to function by air pressure until sufficient steam has been generated to get the required steam pressure for operating the burner. That pressure would be 10 lbs. and more. It will be understood that the use of steam or air is in itself not critical and the burner may be used for heating purposes where there is no steam generated, in which case air may be used exclusively.

With a supply of oil furnished through the pipe 1 and flowing through the bore 10 and

out of the tip of the nozzle, steam or air under pressure is admitted to the pipe 7 and consequently passes through the annular chamber 11, through the spiral passages 15, and out of the circular opening 12, which surrounds the outlet 10 of the fuel.

As the gas under pressure is forced through the spiral passages 15, and thence through the narrow outlet 13, it is given a whirling centrifugal action, and that action, resulting in a vortex of whirling gas surrounding the outlet of the liquid fuel, results in the withdrawal of the fuel from the bore 10 by vacuum or suction action, the breaking up of the fuel, and the carrying it forward and supplying of it to the furnace in a thoroughly atomized condition, most suitable for combustion.

The burner, when properly fed, will produce a real fog-like mist which is thrown to all parts of the combustion chamber, and will produce an intense heat and complete combustion.

I claim:

1. A burner for liquid fuels comprising a hollow imperforate core member adapted to carry fuel to the tip of the burner, a concentric sleeve surrounding the core and co-extensive therewith, a restricting member positioned between the core and sleeve near the tip of the nozzle, the wall of the sleeve being thickened adjacent its outer extremity to form a second restricting member spaced slightly away from the first and forming a chamber therebetween, the second restricting member limiting the outlet of the chamber to a narrow annular slit of cylindrical shape surrounding the tip of the fuel-carrying core, both the bore of the core and the said cylindrical annular slit terminating in the same plane.

2. A liquid fuel burner nozzle comprising a hollow sleeve member and a concentric core member positioned inside the sleeve, the core member having a bore therethrough adapted to carry fuel directly to the tip of the burner, the internal diameter of the sleeve being larger than the external diameter of the core whereby to form a continuous annular passage around the core, an internal flange at the tip of the sleeve restricting said passage around the outer end of the core to a narrow cylindrical slit, a series of spirally shaped flanges on the core inside the said restricting flange of the sleeve and spaced slightly therefrom, the discharge ends of both the bore of the core and the said cylindrical slit terminating in the same plane, and an inlet to the said chamber around the core whereby to supply a gas under pressure.

3. A liquid fuel burner nozzle comprising a core member having a longitudinal bore therethrough, a co-extensive sleeve member positioned about the core and forming an

annular chamber between the core and sleeve, means restricting the size of the said annular chamber at the extreme forward end of the nozzle to form a narrow cylindrical outlet port around the core and from the said annular chamber, the discharge ends of both said bore and the said cylindrical outlet port terminating in the same plane, means positioned in the chamber spaced slightly from the said outlet port whereby to give gaseous fluid passing through the chamber a swirling motion before entering the said outlet port, and connections to supply a liquid fuel to said bore and a gaseous fluid under pressure to the said annular chamber.

4. A liquid fuel burner nozzle comprising a hollow cylindrical casing having its bore restricted adjacent its outer end and enlarged at its inner end, a cylindrical core provided with an axial duct extending completely therethrough and having an annular flange at one extremity neatly fitting within the enlarged bore of the casing and an ex-

ternally spirally grooved collar adjacent its opposite extremity snugly fitting the bore of the casing, the annular flange and collar cooperating with the casing to center the core with respect to the bore thereof and provide an annular chamber therebetween, locking means for preventing relative longitudinal movement between the core and casing, the space between the restricted outer bore of the casing and the exterior of the core forming a narrow annular outlet passage from the chamber, the discharge ends of both said passage and the said axial duct terminating in the same plane, means for supplying a gas under pressure to the annular chamber, and said locking means being recessed to provide a passage registering with the said axial duct for supplying liquid fuel thereto.

In testimony whereof, I sign my name.

WILLIAM T. ADOLPHSEN.

Witness:

EDWIN O. JOHNS.