



US 2007012733A1

(19) **United States**

(12) **Patent Application Publication**  
**OOMEN et al.**

(10) **Pub. No.: US 2007/0127333 A1**

(43) **Pub. Date: Jun. 7, 2007**

(54) **RECORD CARRIER METHOD AND APPARATUS HAVING SEPARATE FORMATS FOR A STEREO SIGNAL AND A DATA SIGNAL**

(30) **Foreign Application Priority Data**

Jul. 20, 1999 (EP)..... 99202383.8

**Publication Classification**

(75) Inventors: **Arnoldus Werner Johannes OOMEN**, Eindhoven (NL); **Leon Maria VAN DE KERKHOFF**, Eindhoven (NL)

(51) **Int. Cl.**  
**G11B 19/02** (2006.01)

Correspondence Address:  
**PHILIPS INTELLECTUAL PROPERTY & STANDARDS**  
**P.O. BOX 3001**  
**BRIARCLIFF MANOR, NY 10510 (US)**

(52) **U.S. Cl.** ..... **369/47.1; 369/275.3**

(57) **ABSTRACT**

(73) Assignee: **KONINKLIJKE PHILIPS ELECTRONICS, N.V., EINDHOVEN (NL)**

The invention relates to a record carrier carrying a stereo signal and a data signal. The data signal comprises a first portion and a remaining portion. A first channel on the record carrier comprises a composite signal. The composite signal is obtained by combining the stereo signal and the first portion of the data signal, preferably by using buried data techniques. A second channel on the record carrier comprises the remaining portion of the data signal. The invention further relates to a method, a recording apparatus and a reproducing apparatus for recording/reproducing the stereo signal and the data signal on a record carrier.

(21) Appl. No.: **11/557,162**

(22) Filed: **Nov. 7, 2006**

**Related U.S. Application Data**

(63) Continuation of application No. 09/787,339, filed on Mar. 16, 2001, now Pat. No. 7,136,346.

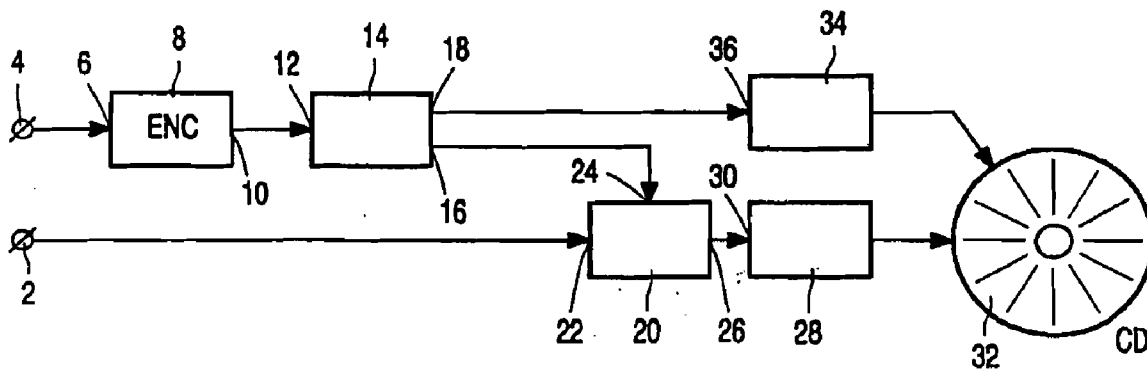

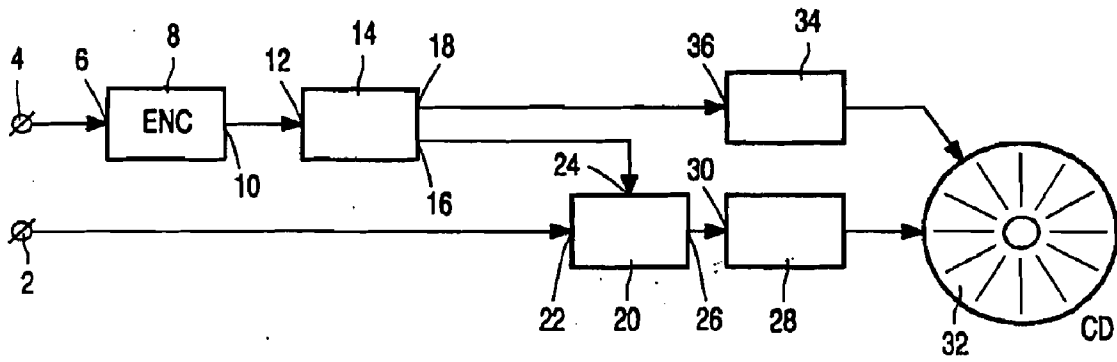

FIG. 1

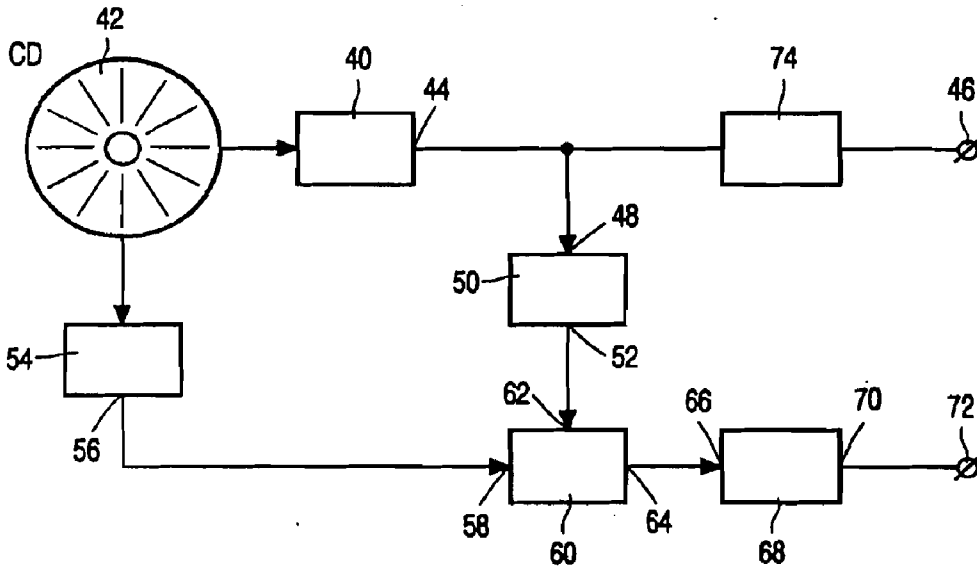

FIG. 2

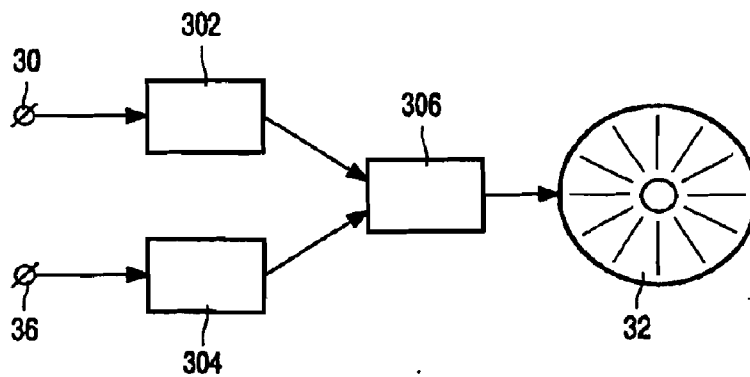

FIG. 3

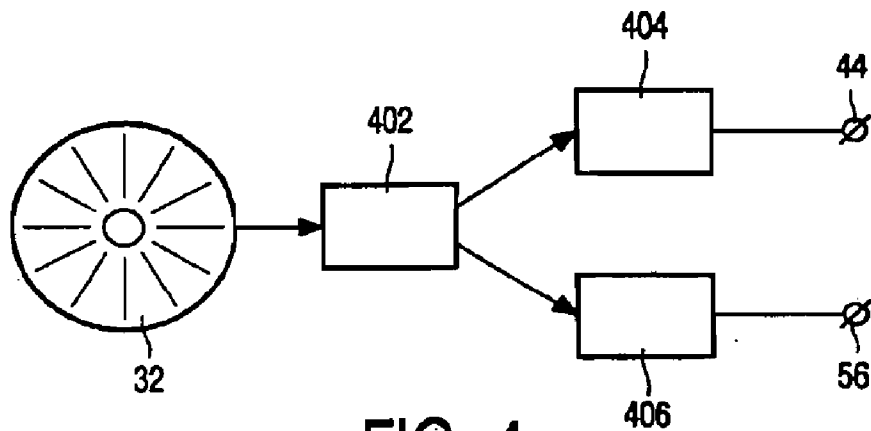

FIG. 4

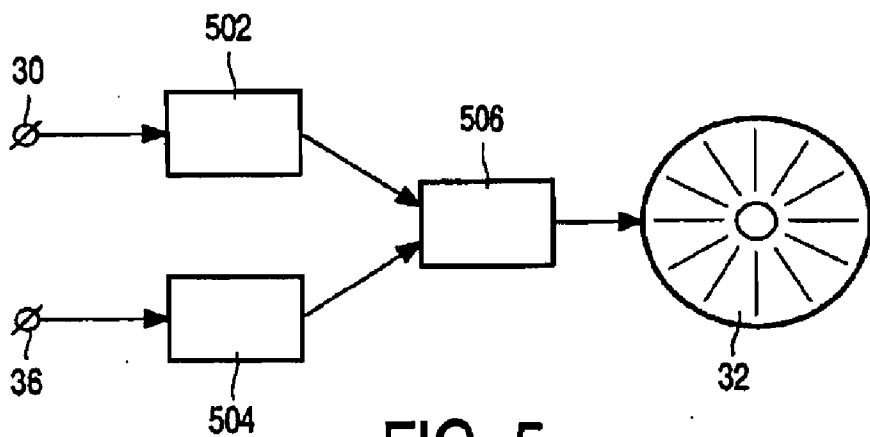

FIG. 5

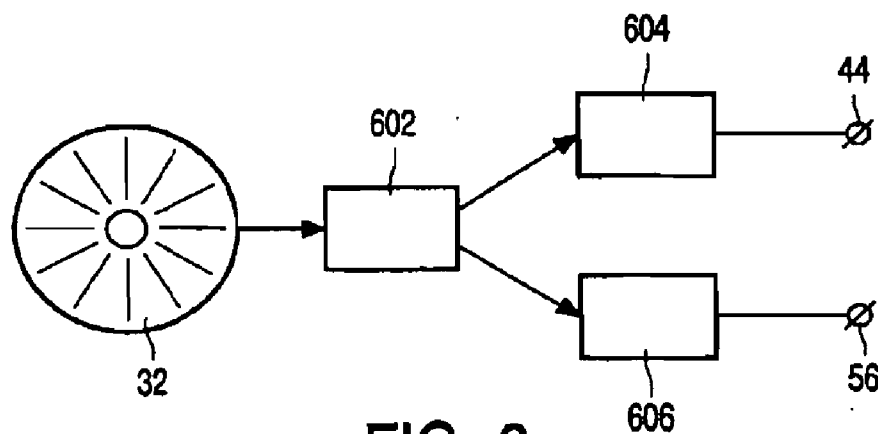

FIG. 6

**RECORD CARRIER METHOD AND APPARATUS  
HAVING SEPARATE FORMATS FOR A STEREO  
SIGNAL AND A DATA SIGNAL**

[0001] This is a continuation of co-pending patent application Ser. No. 09/787,339 file Mar. 16, 2001.

[0002] The invention relates to a record carrier carrying a stereo signal and a data signal, said stereo signal being recorded in a first channel on the record carrier.

[0003] The invention further relates to a method of recording the stereo signal and the data signal on said record carrier, to a recording apparatus carrying out the method and to a reproducing apparatus for reproducing the stereo signal and the data signal.

[0004] A record carrier and apparatuses defined above are known from EP-A-0 372 601. The first channel on the known record carrier has a constant data capacity for carrying the stereo signal and the data signal. Said document describes a general method for burying the data signal in the stereo signal. Sometimes the data capacity of the first channel is not sufficient to carry both the stereo signal and the data signal without losing too much signal quality.

[0005] It is an object of the invention to provide a record carrier able to carry a stereo signal and a data signal with increased data capacity for the stereo signal and the data signal.

[0006] The record carrier in accordance with the invention is characterized in that the data signal comprises a first portion and a remaining portion, said first portion being combined with said stereo signal to obtain a composite signal being recorded in said first channel on said record carrier and the remaining portion being recorded in a second channel on said record carrier.

[0007] In an embodiment of the record carrier, the record carrier is characterized in that said first channel is represented by first variations of a first physical parameter of the record carrier and said second channel is represented by second variations of a second physical parameter of the record carrier, said second physical parameter differing from said first physical parameter.

[0008] The invention is based on the recognition that realizing a second channel on a record carrier enables an increase of the data capacity for recording the stereo signal and the data signal on the record carrier. Such increased data capacity can be used to enable the recording of a data signal with an increased data rate. It might be possible to record a multichannel signal in addition to the stereo signal on the record carrier. For example by using the buried channel techniques a buried channel is generated in the stereo signal for accommodating the first portion of the data signal. In some cases the data capacity in the first channel is not sufficient to carry the entire data signal. Therefore the second channel is used for carrying a remaining portion of the data signal. It should be noted that a record carrier with such second channel is known from U.S. Pat. No. 5,210,738 and U.S. Pat. No. 5,724,327 (PHN 13922). However, said documents do not mention that the data capacity of the buried channel is not sufficient to carry the data signal. Neither do said documents give a solution to increase the data capacity on the record carrier needed for carrying the data signal.

[0009] These and other aspects of the invention will be apparent from and elucidated with respect to the embodiments described hereafter in the figure description in which

[0010] FIG. 1 shows an embodiment of a recording apparatus,

[0011] FIG. 2 shows an embodiment of a reproducing apparatus,

[0012] FIG. 3 shows another embodiment of the first and second writing means in the recording apparatus of FIG. 1,

[0013] FIG. 4 shows another embodiment of the first and second reading means in the reproducing apparatus of FIG. 2,

[0014] FIG. 5 shows a second embodiment of the first and second writing means in the recording apparatus of FIG. 1,

[0015] FIG. 6 shows a second embodiment of the first and second writing means in the reproducing apparatus of FIG. 2.

[0016] FIG. 1 shows a first embodiment of the recording apparatus in accordance with the invention. The recording apparatus is adapted for recording a stereo signal and a data signal, said data signal being a multichannel extension signal. The multichannel extension signal comprises at least one signal such as a center signal, a monophonic surround signal, a surround left signal, a surround right signal or a quadrasonic signal. The apparatus comprises first input terminal 2 for receiving a stereo signal and second input terminal 4 for receiving a multichannel extension signal. The stereo signal and the multichannel extension signal are preferably sampled at a frequency of 44.1 kHz. The second input terminal is coupled to an input 6 of a data-compressing unit 8. The data-compressing unit is adapted to compress the multichannel extension signal and to supply a data compressed multichannel extension signal to an output 10. The specific type of data compressing carried out in the data-compressing unit is not essential for the invention. The output 10 of the data-compressing unit 8 is coupled to input 12 of a splitting unit 14. The splitting unit 14 is adapted to split the received compressed multichannel extension signal into a first portion for supplying to a first output 16 and a remaining portion for supplying to a second output 18. The apparatus further comprises a combining unit 20 with a first input 22 coupled to the first input terminal 2, a second input 24 coupled to the first output 16 of the splitting unit 14 and an output 26. The combining unit is arranged for combining the received stereo signal and the first portion of the compressed multichannel extension signal, preferably by using buried data techniques. Buried data techniques are well known in the art. These techniques make it possible to bury a data channel in the stereo signal. When the stereo signal, for example, contains a left and right channel each consisting of 16 bits/sample, a data channel with an average capacity of 5 bits/sample can be obtained without decreasing the perceptual audio quality of the 16 bits/sample of the left and right signal. Another suitable method is disclosed in EP-A-0 372 601. Said document discloses the so-called hidden channel method for burying additional information in a digital audio signal.

[0017] The apparatus is provided with first writing unit 28. Input 30 of the first writing unit is coupled to the output 26 of the combining unit 20. The first writing unit is adapted to

write the received combination of the stereo signal and the first portion of the data compressed multichannel signal in a first channel of a record carrier **32**. The record carrier is preferably a standard audio CD and the written stereo signal in the first channel can be reproduced by a conventional CD player. The first channel is in that case formed by optical detectable marks in a track, whereby the optically detectable marks are in the form of so-called pits.

[0018] The apparatus is further provided with second writing unit **34**. Input **36** of the writing unit **34** is coupled to the second output **18** of the splitting unit **14**. The second writing unit is adapted to write the remaining portion received at the input **36** in a second channel of the record carrier **32**. The second channel is preferably written by variations of the track. In U.S. Pat. No. 5,724,327 some embodiments of the second channel are disclosed.

[0019] The functioning of the apparatus will now be described in greater detail. The second input terminal **4** receives the multichannel extension signal. The multichannel extension signal comprises for example a left signal, a right signal, a center signal, a surround left signal and a surround right signal and has a sample frequency of 44.1 kHz. Next the multichannel extension signal is data compressed by the data-compressing unit **8**. The compressing unit preferably comprises a perceptual encoder, such as an MPEG-2 audio encoder, for compressing the multichannel extension signal to obtain the data compressed multichannel extension signal. A data compressed multichannel extension signal in the form of a MPEG stream generated by a normal MPEG 2 audio encoder requires for a good signal quality a bit-rate of 384 Kbits/sec. More complex MPEG encoders can provide a MPEG stream comprising high quality signals at 320 Kbits/s.

[0020] The stereo signal received at the first input terminal **2** is supplied to a combination unit **20**. The stereo signal comprises a left signal and a right signal and a sample frequency of 44.1 kHz. The left signal in the stereo signal can be any combination of a left signal, a center signal and a surround left signal or mono surround signal and the right signal in the stereo signal can be any combination of a right signal, a center signal and a surround right signal or mono surround signal. In the combination unit **20** the stereo signal is analyzed with for example buried data techniques to determine bits in the signal that can be used for a buried data channel without decreasing the perceptual quality of the stereo signal. For a standard audio CD the left signal as well as the right signal has 16 bits/sample. By using buried data techniques, burying a data signal in the stereo signal to be stored on the record carrier, typically, an additional capacity of about 30% of the CD capacity becomes available for any data signal. On average this data capacity is 5 bits/sample. The minimum data capacity is 2 bits/sample and is obtained for very low level signals. Thus the data capacity of the buried channel is on average  $2 \times 5 \times 44.1 \text{ kHz} = 441 \text{ kbits/s}$  and minimal 176.4 kbits per second. The minimum data capacity by using buried data techniques ( $=176.4 \text{ kbits/s}$ ) is thus not enough to carry a data compressed multichannel extension signal in the form of a MPEG stream with a good signal quality ( $=384 \text{ kbits/s}$ ).

[0021] As mentioned before a second channel on the record carrier is available. U.S. Pat. No. 5,724,327 (PHN 13.922) discloses some embodiments of a second channel. If

an audio sample comprises 16 bits, a data capacity near to 2-bits/audio sample can be obtained by variations in the width of optical detectable marks. Thus for a standard audio CD this means a capacity of  $2 \times 2 \times 44.1 \text{ kHz} = 176.4 \text{ kbits/s}$ . Together with the capacity of the buried channel in the first channel the record carrier can carry at least a signal with a bitrate of 352.8 kbits/s and on average a bitrate of 617.4 kbits/s. This total capacity is sufficient to carry most MPEG streams with a good quality generated by a MPEG 2 audio encoder.

[0022] To distribute the data compressed multichannel extension signal over the buried data channel in the stereo signal and the second channel, the data compressed multichannel extension signal is split by the splitting unit **14** in a first portion and a remaining portion. The splitting is preferably done by demultiplexing of the data compressed multichannel extension signal. The multiplexing could be done by repetitively applying five bytes of the data compressed multichannel extension signal to the first portion and applying two bytes to the remaining portion. It is also possible to have an adaptive multiplexer, where the distribution is adaptively controlled. The first portion is supplied to the combining unit **24** and is combined by using for example the buried data techniques with the stereo signal to obtain a composite signal. The first writing unit writes the composite signal in the first channel on the record carrier. The first channel could be written on the record carrier by first variations of a first physical parameter of the record carrier, for example in the form of optical detectable marks which alternate with intermediate areas. The optically detectable marks may be in the form of so-called pits on a standard CD. The optically detectable marks are arranged along a track. The second writing unit writes the remaining portion in the second channel on the record carrier. The second channel could be written on the record carrier by second variations of a second physical parameter, for example in the form of variations of the optical detectable mark transverse to the track direction such as variation of the width of the marks.

[0023] An advantage of the recording apparatus in accordance with the invention is that it produces record carriers, for example CD's, that can be used in CD players in accordance with the current CD standard to reproduce the stereo signal. Said CD players can only read the first channel and thus the composite signal. The composite signal is in the form of a stereo signal. By using the buried data techniques the perceptual quality level of the stereo signal in the composite signal is not decreased. As a result of which a customer will hear almost the same signal quality as the quality of the stereo signal that does not have a buried data channel.

[0024] Another advantage of the record carrier in accordance with the invention is that the whole content on the record carrier can not be copied with normal CD recorders on the market today. Those CD recorders are able to read the first channel and not able to read the second channel. A copy made by said CD recorders will only contain the composite signal and thus only the first portion of the multichannel extension signal. As a result, the multichannel data signal cannot be reproduced from said copy, thus providing a copy-protection means.

[0025] FIG. 2 shows a first embodiment of the reproducing apparatus for reproducing a stereo signal and a data

signal from a record carrier in accordance with the invention. The data signal in this embodiment is a multichannel extension signal. The apparatus comprises a first reading unit **40** for reading a composite signal written in a first channel on a record carrier **42** and supplying the composite signal to an output **44**. This first channel is preferably in the form of a channel that carries the 16 bit/sample stereo signal on a standard CD. The output **44** of the first reading unit **40** is coupled via a converting unit **74** to a first output terminal **46** of the apparatus. The converting unit converts the composite signal into the stereo signal. The first output terminal **46** could be coupled to, for example a power amplifier, an equalizer or speakers.

[0026] The output **44** of the first reading unit **40** is further coupled to an input **48** of the extracting unit **50**. The extracting unit **50** is adapted to extract a first portion of a data compressed multichannel extension signal from the composite signal received at the input **48**, and to supply the first portion to an output **52**.

[0027] The apparatus further comprises a second reading unit **54** for reading a remaining portion of the data compressed multichannel signal written in a second channel on the record carrier **42** and supplying the remaining portion to an output **56**. The second channel is preferably in the form of second variation of a second physical parameter of the record carrier whereby the second variation of the second physical parameter differs from a first variation of a first physical parameter used for carrying the first channel on the record carrier. U.S. Pat. No. 5,724,327 (PHN 13.922) discloses some possible embodiments of the second channel. Said document discloses variation of the position of a track on the record carrier, variation of the width or depth of pits in the track or variations of the frequency of the recovered data clock. The second reading unit is adapted to detect said second physical parameter, and to supply the remaining portion in response to said detected second physical parameter. The output **56** of the second reading unit **54** is coupled to a first input **58** of a combination unit **60**. The output **52** of the extraction unit **50** is coupled to a second input **62** of the combination unit **60**. The combination unit **60** is adapted to combine the first portion of the data compressed multichannel extension signal and the remaining portion of the data compressed multichannel extension signal received at the second and first input respectively, and to generate the multichannel extension signal for supplying to a output **64**. The output **64** is coupled to an input **66** of decompressing unit **68**.

[0028] The decompressing unit **68** is adapted to decompress the data compressed multichannel extension signal received at the input **66** into a multichannel extension signal. An output **70** of the decompressing unit is coupled to a second output terminal **72** of the apparatus. The second output terminal **72** could be coupled to a power amplifier, an equalizer or a speaker system.

[0029] The functioning of the reproducing apparatus will now be described in greater detail. The record carrier **42** carrying the stereo signal and the multichannel extension signal comprises a first channel carrying a composite signal comprising the stereo signal and a first portion of the multichannel extension signal, and a second channel carrying a remaining portion of the multichannel extension signal. The first channel is represented by first variations of a

first physical parameter of the record carrier and the second channel is represented by second variations of a second physical parameter. The first channel is preferably as on a standard CD, carrying a stereo signal. The first reading unit **40** reads the composite signal from the first channel of the record carrier by detecting first variations of a first physical parameter of the record carrier. The composite signal comprises the stereo signal and the first portion of a data compressed multichannel signal. Thus the composite signal can be supplied directly to the first output terminal for reproduction of the stereo signal. In that case the conversion unit **74** is unnecessary. The extraction unit **50** is arranged for extracting the first data compressed multichannel extension signal from the composite signal.

[0030] The second reading unit **54** reads the remaining portion of the data compressed multichannel extension signal from the second channel by detecting second variations of a second physical parameter of the record carrier. If the variations of the second physical parameter have the form of variations of the width of the optical detectable marks, the variations in the width of the mark result in an additional intensity modulation in a radiation beam scanning the track. In a standard CD player only the intensity modulation due to the variations of the first physical parameter can be detected from the radiation beam. An arrangement for detecting the second channel in the form of variations of the track positions in a direction transverse to the track direction is described in U.S. Pat. No. 5,724,327. The combining unit **60** is adapted to combine the first portion of the data compressed multichannel extension signal and the remaining portion. The combining unit **60** performs preferably the multiplexing of the first portion and the remaining portion to obtain the data compressed multichannel extension signal. The data compressed multichannel extension signal can be an MPEG 2 audio stream generated by an MPEG-2 audio encoder. The multichannel extension signal comprises for example a left signal, a right signal, a center signal, a surround left signal and a surround right signal. The multichannel extension signal is applied to the second output terminal for reproduction by for example a speaker system.

[0031] FIG. 3 shows another embodiment of the first and second writing means in the recording apparatus of FIG. 1. A channel modulation unit **302** receives the composite signal supplied to its input and processes the composite signal to obtain a sequence of m-bit channel words. Preferably the channel modulation unit comprises an n-m channel modulator. A generator unit **304** receives the remaining portion supplied to its input and generates p merging bits in response to said remaining portion. An unit **306** receives the sequence of m-bit channel words and p merging bits and inserts the p merging bits between adjacent m-bit channel word to obtain a signal to be written on the record carrier **32**. The p merging bits are normally used to prevent (d,k) constraint violations between adjacent channel words and for the additional task of DC control. A method for generating p merging bits carrying an additional signal and preventing for (d,k) constraints violations between adjacent channel words is described in the non pre-published patent application EP 99202061.0 (PHN 17.520). The data capacity for the additional signal thus obtained, is used to carry the remaining portion. The first writing unit **28** in the apparatus of FIG. 1 comprises the units with reference number **302** and **306**. The second writing unit **34** in the apparatus of FIG. 1 comprises the units with reference number **302304** and **306**.

[0032] FIG. 4 shows another embodiment of the first and second reading means in the reproducing apparatus of FIG. 2. A unit 402 reads a reproduction signal from the record carrier 32. The reproduction signal comprises a sequence of m-bit channel words with p merging bits between each time adjacent m-bit channel words. The unit 402 split said reproduction signal into a sequence of m-bit channel words and said p merging bits. The sequence of m-bit channel words is supplied to a channel demodulator unit 404 arranged for preferably m-n channel modulation to obtain the composite signal. The composite signal, which is in the form of a standard digital stereo signal, is supplied to output terminal 44. The p merging bits are supplied to a processing unit 406. The processing unit 406 is arranged for processing the p merging bits to obtain the remaining portion for supplying to output terminal 56. The first reading unit 40 in the apparatus of FIG. 2 comprises the units with reference number 402 and 404. The second reading unit 54 in the apparatus of FIG. 2 comprises the units with reference number 402 and 406.

[0033] FIG. 5 shows a second embodiment of the first and second writing means in the recording apparatus of FIG. 1. A processing unit 502 receives the composite signal supplied to its input and processes the composite signal to obtain a sequence of q byte blocks. The processing unit can comprise a cross-interleaved Reed-Solomon encoder. The value of q is 32 for the standard CD format. A subcode encoder 504 receives the remaining portion supplied to its input and generates an r byte subcode in response to said remaining portion. The subcode in the standard CD format is essentially an auxiliary data stream. At least one bit of said r byte subcode such as the U-subcode is obtained in response to the remaining portion. An A unit 506 receives the sequence of q byte blocks and said r byte subcode and inserts the r byte subcode between adjacent m-bit channel word to obtain a signal to be written on the record carrier 32. Preferably prior to writing said signal on the record carrier, the signal is channel encoded by for example an EFM encoder. The first writing unit 28 in the apparatus of FIG. 1 comprises the units with reference number 502 and 506. The second writing unit 34 in the apparatus of FIG. 1 comprises the units with reference number 502, 504 and 506.

[0034] FIG. 6 shows a second embodiment of the first and second writing reading means in the reproducing apparatus of FIG. 2. A unit 602 reads a reproduction signal from the record carrier 32. The reproduction signal comprises a sequence of q byte blocks with r byte subcodes between each time adjacent q byte blocks. The unit 602 split said reproduction signal into a sequence of q byte blocks and said r byte subcodes. The splitting is based upon the physical position of q byte blocks and the subcodes in the reproduced signal. The sequence of q byte blocks is supplied to a processing unit 604 arranged for processing the sequence of q byte blocks to obtain the composite signal. The processing unit may perform the operations Reed-Solomon decoding and de-cross-interleaving. The composite signal, which is in the form of a standard digital stereo signal, is supplied to output terminal 44. The r byte subcodes are supplied to a processing unit 606. The processing unit 606 is arranged for processing the r byte subcodes to obtain the remaining portion from at least one bit of the r byte subcodes. The remaining portion is supplied to output terminal 56. The first reading unit 40 in the apparatus of FIG. 2 comprises the units with reference number 602 and 604. The second reading unit

54 in the apparatus of FIG. 2 comprises the units with reference number 602 and 606.

[0035] Whilst the invention is described with reference to preferred embodiments thereof, it is to be understood that these are not limiting examples. Thus various modifications may become apparent to those skilled in the art, without departing from the scope of the invention, as defined by the claims. As an example, the multichannel extension signal comprising the left signal, right signal, center signal, surround left signal and surround right signal could be an extension signal comprising pictures, video or computer data. Further, in an alternative embodiment the splitting unit could be arranged to scramble the data compressed multichannel extension signal into a scrambled signal and to generate a first portion comprising the scrambled signal and a remaining portion comprising a scrambling key. In another embodiment of the record carrier the first portion comprises the center signal and the remaining portion comprises the surround left signal and surround right signal. Other channel modulators as the mention n to m modulator may be used.

[0036] The word 'comprising' does not exclude the presence of other elements or steps than those listed in a claim. Any reference signs do not limit the scope of the claims. The invention can be implemented by means of both hardware and software. Several "means may be represented by the same item of hardware. Further the invention lies in each and every novel feature or combination of features.

1. A record carrier carrying a stereo signal and a data signal, said stereo signal being recorded in a first channel, characterized in that the data signal comprises a first portion and a remaining portion, said first portion being combined with said stereo signal to obtain a composite signal being recorded in said first channel on said record carrier and the remaining portion being recorded in a second channel on said record carrier.

2. The record carrier as claimed in claim 1, characterized in that said first portion being combined with said stereo signal by using buried data techniques.

3. The record carrier as claimed in claim 1, characterized in that the data signal comprises a data compressed multichannel extension signal being a representation of a multichannel extension signal.

4. The record carrier as claimed in claim 3, characterized in that the multichannel extension signal comprises a center channel signal.

5. The record carrier as claimed in claim 3, characterized in that the multichannel extension signal comprises a surround left signal and a surround right signal.

6. The record carrier as claimed in claim 3, characterized in that the data compressed multichannel extension signal is a perceptually encoded representation of the multichannel extension signal.

7. The record carrier as claimed in claim 3, characterized in that the first portion represents a partial representation of the multichannel extension signal.

8. The record carrier as claimed claim 1 characterized in that said first channel is represented by first variations of a first physical parameter of the record carrier and said second channel is represented by second variations of a second physical parameter of the record carrier, said second physical parameter differing from said first physical parameter.

9. The record carrier as claimed in claim 1, characterized in that said composite signal in said first channel and said

remaining portion in said second channel being obtained by n to m channel modulation of the composite signal into a sequence of m-bit channel words, insertion of p merging bits between said m-bit channel words, said merging bits being modified in response to said remaining portion.

10. The record carrier as claimed in claim 1, characterized in that said composite signal in said first channel and said remaining portion in said second channel being obtained by processing the composite signal into a sequence of q byte blocks, insertion of a r byte subcode between said q byte blocks, at least one bit of said r byte subcode being obtained in response to said remaining portion.

11. The record carrier as claimed in claim 10, characterized in that said composite signal in said first channel and said remaining portion in said second channel being obtained by further channel encoding of the sequence of q byte blocks and r byte subcodes

12. Method for recording a stereo signal and a data signal on a record carrier comprising the steps: -writing said stereo signal in a first channel on the record carrier characterized in that the method further comprises the steps: -splitting the data extension signal into a first portion and a remaining portion, -writing said remaining portion of said data signal in a second channel on the record carrier, -combining said first portion to said stereo signal prior to writing said stereo signal in said first channel to obtain a composite signal -writing the composite signal in the first channel.

13. Method as claimed in claim 12, characterized in that the combining step is performed by using buried data techniques.

14. Method as claimed in claim 12, characterized in that the method further comprises the step data compressing a multichannel extension signal into the data signal. 15. Method as claimed in anyone of claim 12 to 14, characterized in that the first channel is written on the record carrier by first variations of a first physical parameter of the record carrier and that the second channel is written on the record carrier by second variations of a second physical parameter of the record carrier, said second physical parameter differing from said first physical parameter.

15. (canceled)

16. Method as claimed in claim 12, characterized in that the method further comprises the steps n to m channel modulation of the composite signal to obtain a sequence of m-bit channel words, generating p merging bits in response to said remaining portion, inserting said p merging bits between said m-bit channel words and writing the thus obtained signal on the record carrier.

17. Method as claimed in claim 12, characterized in that the method further comprises the steps processing the composite signal into a sequence of q byte blocks, generating at least one bit in response to said remaining portion for insertion in a r byte subcode, inserting said r byte subcode between said q byte blocks and writing the thus obtained signal on the record carrier.

18. Recording apparatus for carrying out the method as claimed in anyone of the claims 12.

19. Reproducing apparatus for reproducing a stereo signal and a data signal from a record carrier, comprising -first reading means for reading a first reproduction signal from a first channel on the record carrier, characterized in that the apparatus further comprises -means for extracting a first portion of the data signal from the first reproduction signal, -second reading means for reading a remaining portion of

the data signal from a second channel on the record carrier, -combining means for combining the first portion and the remaining portion to obtain the data signal -means for converting the first reproduction signal into said stereo signal.

20. Reproducing apparatus as claimed in claim 19 characterized in that the extraction means are adapted for extracting the first portion of the data signal from the first reproducing signal by using buried data techniques.

21. Reproducing apparatus as claimed in claim 19, characterized in that the data signal comprises a data compressed multichannel extension signal, whereby the apparatus further comprises -decompressing means for decompressing the data compressed multichannel extension signal into a multichannel extension signal.

22. Reproducing apparatus as claimed in claim 21, characterized in that the multichannel extension signal comprises a center channel signal.

23. Reproducing apparatus as claimed in claim 21, characterized in that the multichannel extension signal comprises a surround left signal and a surround right signal.

24. Reproducing apparatus as claimed in claim 19, characterized in that the first reading means are arranged for reading the stereo signal from the first channel by detecting first variations of a first physical parameter of the record carrier and that the second reading means are arranged for reading the remaining part of the data signal from the second channel by detecting second variations of a second physical parameter of the record carrier, said second physical parameter differing from said first physical parameter.

25. Reproducing apparatus as claimed in claim 19, characterized in that said first reading means comprises means for splitting said first reproduction signal into a sequence of m-bit channel words and p merging bits, the converting means comprises means for m-n channel demodulation of said m-bit channel words to obtain the composite signal, and said second reading means comprises means for processing said p merging bits to obtain said remaining portion.

26. Reproducing apparatus as claimed in claim 19, characterized in that said first reading means comprises means for splitting said reproduction signal into a sequence of q byte blocks and r byte subcodes, processing means for processing said q-byte blocks to obtain the composite signal, and said second reading means comprises means for processing at least one bit from said r byte subcodes to obtain said remaining portion.

27. A record carrier carrying a stereo signal and a data signal, the data signal comprising a first portion and a remaining portion, said first portion being combined with said stereo signal to obtain a composite signal which is recorded using said first physical property on said record carrier and the remaining portion being recorded using a second physical property on said record carrier different from said first physical property.

28. The record carrier according to claim 27 wherein the first physical property is variations in the reflectance of a track looping around a disc shaped record carrier and the second physical property is variations in the radial position of the track.

29. Method for recording a stereo signal and a data signal on a record carrier comprising the steps: -splitting the data signal into a first portion and a remaining portion, -combining said first portion to said stereo signal to obtain a composite signal -writing the composite signal in the first



physical property. -writing said remaining portion of said data signal in a second physical property on the record carrier different from said first physical property.

**30.** Reproducing apparatus for reproducing a stereo signal and a data signal from a record carrier, comprising: -first reading means for reading a first reproduction signal from a first physical property on the record carrier, -means for extracting a first portion of the data signal from the first reproduction signal, -second reading means for reading a

remaining portion of the data signal from a second physical property on the record carrier wherein said first physical property is different from said second physical property. -combining means for combining the first portion and the remaining portion to obtain the data signal -means for converting the first reproduction signal into said stereo signal.

\* \* \* \* \*