



(22) Date de dépôt/Filing Date: 2007/09/25

(41) Mise à la disp. pub./Open to Public Insp.: 2008/03/28

(45) Date de délivrance/Issue Date: 2010/02/16

(30) Priorité/Priority: 2006/09/28 (US60/827,319)

(51) Cl.Int./Int.Cl. *E21B 33/06* (2006.01)

(72) Inventeurs/Inventors:
LANE, WILLIAM C., US;
HANSON, ANDREW J., CA

(73) Propriétaire/Owner:
WEATHERFORD/LAMB, INC., US

(74) Agent: GOODWIN MCKAY

(54) Titre : BLOC OBTURATEUR DE Puits ET COLLIER POUR TIGE DE POMPAGE

(54) Title: BLOWOUT PREVENTER AND PUMP ROD CLAMP

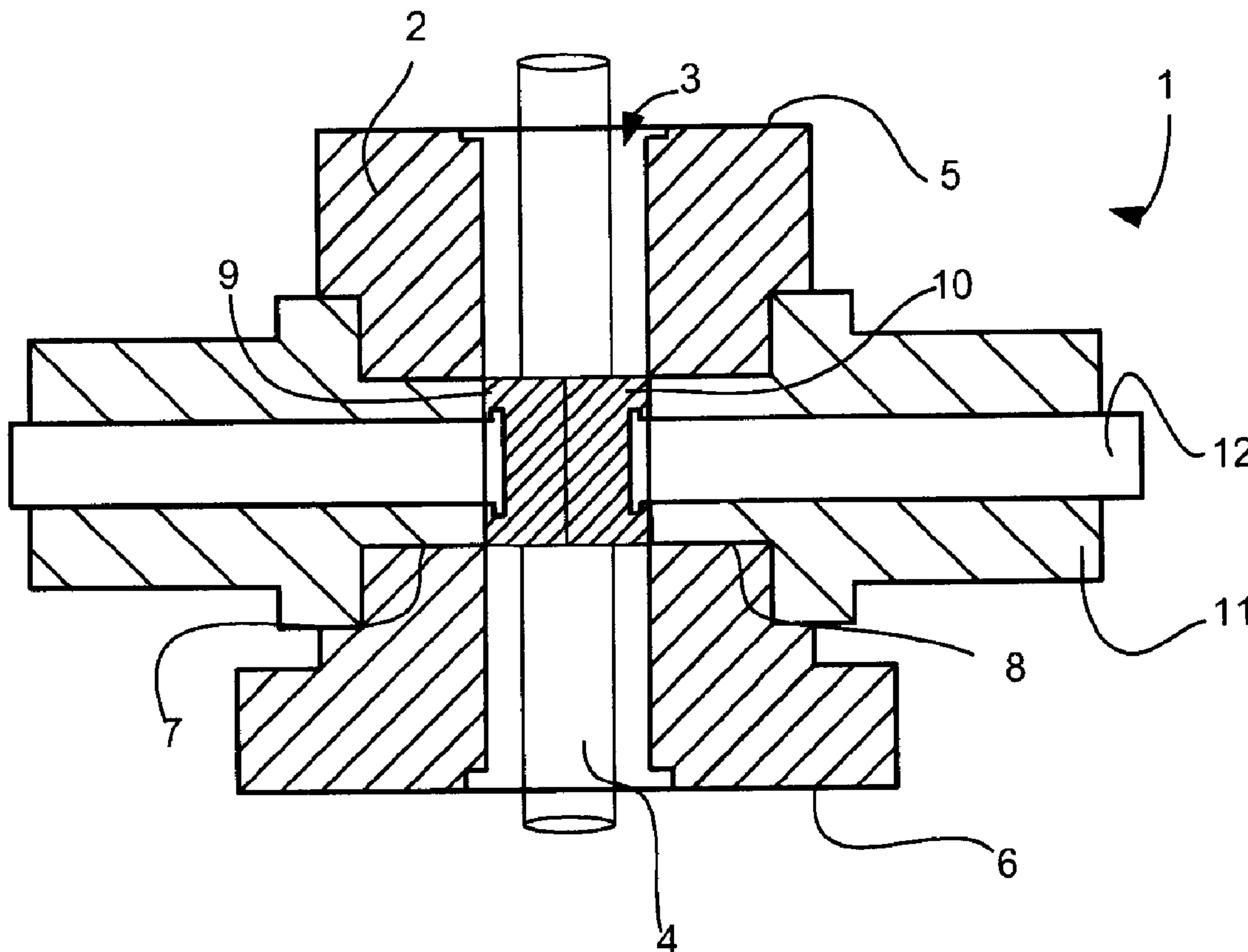

(57) Abrégé/Abstract:

Disclosed herein is a combined pump rod clamp/BOP for use in a wellbore. The pump rod clamp/BOP is capable of supporting the weight of the pump rod, preventing axial or rotational movement of the rod, and simultaneous preventing fluids from escaping from

(57) **Abrégé(suite)/Abstract(continued):**

the well, while maintaining electrical conductivity between the BOP and the polish rod. The pump rod clamp/BOP features rams having an arcuate channel for clamping a pump rod. The rams include a gripping non-metallic material non-releasably disposed on the engaging face of the ram. The non-metallic material can coat the entire engaging face of the ram, the arcuate channel only, or part of the arcuate channel. The non-metallic gripping material prevents the rams from damaging the pump rod when they engage the rod.

1

2

ABSTRACT

3

4

5

6

7

8

9

10

11

12

13

Disclosed herein is a combined pump rod clamp/BOP for use in a wellbore. The pump rod clamp/BOP is capable of supporting the weight of the pump rod, preventing axial or rotational movement of the rod, and simultaneously preventing fluids from escaping from the well, while maintaining electrical conductivity between the BOP and the polish rod. The pump rod clamp/BOP features rams having an arcuate channel for clamping a pump rod. The rams include a gripping non-metallic material non-releasably disposed on the engaging face of the ram. The non-metallic material can coat the entire engaging face of the ram, the arcuate channel only, or part of the arcuate channel. The non-metallic gripping material prevents the rams from damaging the pump rod when they engage the rod.

BLOWOUT PREVENTER AND PUMP ROD CLAMP

FIELD OF THE INVENTION

This invention relates generally to oil and/or gas production and more specifically to a combination pump rod clamp and blowout preventer (BOP) for oil, gas, or water wells, and in particular to a pump rod clamp / blowout preventer having a pump rod clamping or gripping capability sufficient to support a pump rod and providing enhanced safety from static charge buildup.

BACKGROUND OF THE INVENTION

Blowout preventers (BOPs) and pump rod clamps (aka polished rod clamps) have been generally known in the art for some time. Pump rod clamps are used to suspend the rod within the well, and/or to prevent rotational movement of the pump rod. Many types of pump rod clamps are known. Some rod clamps use a pair of rams that are driven radially inward to contact the pump rod and hold it in place. Others use wedges inserted around the rod. Still others use a pair of rams that can be bolted around the exterior surface of the rod and hung from a mandrel or other support member.

BOPs are used to seal off the well and contain its contents under a variety of different situations. For example, during the servicing of a wellhead one or more blowout preventers are often used to seal against the pump or polished rod to contain the contents of the well when downstream equipment is removed or disassembled for servicing. In other instances blowout preventers may be used to seal off a well where the pump rod is removed, or in the event of a failure of the pump rod. Blowout preventers typically include a pair of rams that are received within cylinders extending through a BOP housing and situated generally perpendicular to the longitudinal axis of the well casing. Typically the end of each ram has a semi-circular channel on its face to allow it to seal against the exterior surface of the pump rod when the BOP is actuated by driving the rams inward. The faces of the rams may include an elastomer or other sealing

1 mechanism to ensure that a fluid tight seal is created when the rams fully engage
2 the pump rod.

3

4 **Generally, BOPs and pump rod clamps are separate pieces of equipment.**
5 **The BOP is typically capable of sealingly engaging the pump rod to prevent blow**
6 **out, but does not engage the rod forcefully enough to suspend the rod or prevent**
7 **the rod from rotating. Thus a rod clamp is required for this duty. Likewise,**
8 **though rod clamps grip the rod forcefully enough to suspend the rod or prevent**
9 **its rotation, the engagement between the rod clamp and the rod is not typically a**
10 **sealing engagement and thus does not prevent the contents of the well from**
11 **escaping. Thus, there is a need for a single piece of equipment that can serve**
12 **double-duty as both a pump rod clamp and a BOP.**

13

14 **Recent disclosures have purported to describe particular embodiments of**
15 **combination BOP/well rod clamp devices. One example is U.S. Patent No.**
16 **7,000,888, by Wright et al., ("the '888 patent"). The '888 patent describes a**
17 **pump rod clamp having rams featuring arcuate channels to sealingly engage a**
18 **pump rod. The rams include one or more gripping inserts releasably secured to**
19 **the rams, or a non-metallic coating applied to the rams, providing an electrically**
20 **insulating barrier between the pump rod clamp and the pump rod.**

21

22 **U.S. Patent No. 6,843,313, by Hult ("the '313 patent") and related U.S.**
23 **Patent Application Publication No. 2005/0045323 A1, describe a pump drive**
24 **head for a progressing cavity pump that includes a pump rod lock-out clamp that**
25 **is integral with or adjacent to a blow-out-preventer. One embodiment described**
26 **in these references includes a BOP that serves as a lock out clamp for well**
27 **servicing. The BOP/lock-out clamp includes metal pistons that are forced against**
28 **the pump rod to grippingly engage in metal-to-metal contact. The inner end of**
29 **the pistons includes an arcuate recess with curvature corresponding to the pump**
30 **rod. The pistons also include a narrow elastomeric seal running across the**
31 **vertical flat face of the piston, along the arcuate recess, along the mid height of**

1 the piston and then circumferentially around the piston. The elastomeric seals
2 seal between the pistons, between the pistons and the pump rod, and between
3 the pistons and the piston bores, thereby preventing fluid from escaping up the
4 well bore when the pistons are engaged with the pump rod.

5

6

SUMMARY OF THE INVENTION

7 Disclosed herein is a combination pump rod clamp/BOP. The pump rod
8 clamp/BOP has a housing having a lateral bore for receiving a pump rod. Rams
9 are contained in the housing for engaging the pump rod with strength capable of
10 supporting the weight of the pump rod and preventing axial or rotational
11 movement of the rod. When the pump rod clamp/BOP is activated, i.e., when the
12 rams are engaged with the pump rod, the rams also seal off the lateral bore,
13 preventing fluids from escaping from the well through the bore.

14

15 The rams have an arcuate channel for clamping the pump rod and also
16 include a gripping non-metallic material non-releasably disposed on the face of
17 the ram. The non-metallic material can coat the entire leading face of the ram,
18 the arcuate channel only, or part of the arcuate channel. These and other
19 features will be apparent in view of the below description and the attached
20 drawings.

21

22

BRIEF DESCRIPTION OF THE DRAWINGS

23

FIG. 1A illustrates a pump rod clamp/BOP in a deactivated position.

24

25

FIG. 1B illustrates a pump rod clamp/BOP in an engaged (activated)
position.

26

27

FIG. 2 illustrates a ram for a pump rod clamp/BOP, the ram having a non-
metallic gripping material non-releasably disposed thereon.

28

29

FIG. 3 illustrates a top-down view of rams engaging a pump rod, as when
a pump rod clamp/BOP is in an activated position.

30

31

FIG. 4 illustrates a ram for pump rod clamp/BOP having a non-metallic
non-releasable insert.

1

2

DETAILED DESCRIPTION OF THE INVENTION

3 In the FIGS. like numbers represent like elements. FIGS. 1A and 1B
4 illustrate a BOP/pump rod clamp according to the present disclosure. Pump rod
5 clamp/BOP 1 includes a central housing 2 having a longitudinal bore 3 extending
6 through the central housing 2 for receiving a pump rod 4. Central housing 2 may
7 contain upper and lower flanges or threaded connections, 5 and 6 respectively,
8 for mounting the housing to wellhead equipment. As is common with most
9 blowout preventers, central housing 2 further includes a pair of opposed radial
10 bores 7 and 8 that are generally perpendicular to, and that terminate at,
11 longitudinal bore 3. Rams 9 and 10 are slidably received within bores 7 and 8.
12 One or more actuators 11 are used to move rams 9 and 10 between a
13 deactivated position FIG. 1A wherein rams 9 and 10 do not engage the exterior
14 surface of the pump rod and an activated position wherein rams 9 and 10 extend
15 into longitudinal bore 7 and 8 and grippingly engage the exterior surface of the
16 pump rod 4. Any of a variety of actuators may be used to move the rams
17 between their activated and deactivated positions. Such mechanisms include
18 manual, hydraulic, pneumatic, or electric actuators. In the embodiment shown,
19 actuators 11 include stems 12 that can be threadably received within the
20 actuators. The inner most ends of the stems 12 are attached to rams 9 and 10
21 and are free to rotate with respect to the rams. Stems 12 can be rotated
22 manually, electrically, pneumatically, or the like to move rams 9 and 10 between
23 engaged and disengaged positions.

24

25 FIG. 2 illustrates a ram 9, having a engaging face 21 directed generally
26 toward longitudinal bore 3 (and hence toward the exterior surface of a pump rod
27 received within the longitudinal bore). Leading face 21 includes an arcuate
28 channel 22 in general alignment with longitudinal bore 3 and a pump rod
29 received therein. Arcuate channel 22 is positioned in such a manner that, when
30 the rams are moved inwardly to their activated position, arcuate channel 22

1 encompasses the pump rod and grippingly engages the exterior surface of the
2 rod.

3
4 Engaging face 21 includes a non-releasable non-metallic material 23 for
5 making contact with the pump rod to securely hold the rod in place when the
6 rams are moved to their activated position. FIG. 3 illustrates a top-down cross
7 sectional view of rams 9 and 10 engaging a pump rod 4. Non-metallic material
8 23 makes contact with pump rod 4 and holds the rod in place. Leading faces 21
9 sealingly engage each other, thereby preventing fluids from escaping up bore 3.
10 The non-metallic gripping material can be disposed only (or substantially only) in
11 the arcuate channel as shown in FIG. 2 or can partially or totally coat the entire
12 leading face 21.

13
14 FIG. 4 illustrates an alternative embodiment of ram 9 including gripping
15 inserts 41 disposed in arcuate channel 22. Gripping inserts 41 can be made of
16 any suitable non-metallic material, as described above. Gripping inserts 41 are
17 joined to ram 9 using any suitable non-releasable method. For example, gripping
18 inserts 41 can be non-releasably press-fit into receiving cavities machined into
19 arcuate channel 22.

20
21 The non-metallic material can be any non-metallic material suitable for
22 grippingly engaging a pump rod. The non-metallic material presents a hard
23 surface for engaging the exterior of the pump rod without scoring or galling the
24 rod. Traditional rod clamps that permit metal-to-metal contact often gall the
25 surface of the rod and create burs, ridges, and other marks that can rip or tear
26 packing material when the rod is pulled from the well. The non-metallic material
27 reduces the likelihood of damage to the exterior of the rod. The non-metallic
28 material can have a slightly roughened texture. As used herein, non-metallic
29 material refers to materials that are not metals or alloys.

30

1 Suitable non-metallic materials include elastomers such as rubbers,
2 polymers, and the like, ceramics, carbides, nitrides, composites, metal oxides,
3 etc. Composites commonly used for automobile break shoes are particularly
4 suitable. Such materials include chrysotile materials, metal oxides, and
5 composites containing metal oxides. Metal oxides, such as aluminum oxide are
6 also particularly suitable.

7

8 The non-metallic material can be affixed to the rams by any suitable non-
9 releasable method. For example, the material can be glued to the ram using a
10 durable gluing material such as a resin, epoxy, or the like. If the non-metallic
11 material is amenable to brazing, as in the case of carbides, for example, brazing
12 can be used. Non-releasably form fitting, press fitting, molding, or interference
13 fitting can also be used. The non-metallic material can be deposited directly on
14 the ram, spray coated onto the ram, or deposited chemically onto the ram, etc.
15 According to one embodiment, the arcuate channel includes pockets for
16 receiving a band of the non-metallic material. The non-metallic material can be
17 press fit, or otherwise non-releasably disposed within the pockets, as shown in
18 FIG. 4. Generally the methods of applying the non-metallic material to the rams
19 in a non-releasable manner provide a high degree of rigidity in the structure.

20

21 The non-metallic material may or may not provide an insulating barrier
22 between the rams and the pump rod and/or between the pump rod and the pump
23 rod clamp/ BOP. According to one embodiment, the non-metallic material does
24 not provide such electrical insulation. In such an embodiment, the pump rod and
25 the pump rod clamp/ BOP may be maintained in electrical equilibrium (i.e.,
26 electrical contact is provided between the pump rod clamp/ BOP and the pump
27 rod) to prevent static charge buildup between the pump rod and the pump rod
28 clamp/ BOP. Such electrical equilibrium may be provided by a shunt wire,
29 Conductive coatings, conductive seals, one or more metallic tabs, non-grippingly
30 engaging metallic round nose spring plunger, or the like to maintain electrical
31 equilibrium between the pump rod and the housing of the pump rod clamp/ BOP.

1 It should be understood that the inventive concepts disclosed herein are
2 capable of many modifications. To the extent such modifications fall within the
3 scope of the appended claims and their equivalents, they are intended to be
4 covered by this patent.

What is claimed is:

- 5 comprising:
1. A pump rod clamp/blowout preventer for use in a well,
10 rod and prevent fluids from escaping from the well through the bore; the rams comprising:
an engaging face having an arcuate channel situated to receive the pump rod when the ram is the activated position, and
15 a non-metallic material non-releasably disposed on at least a portion of the engaging face for contacting the pump rod.
 2. The pump rod clamp/blowout preventer of claim 1, wherein the non-metallic material covers the entire engaging face.
 - 20 3. The pump rod clamp/blowout preventer of claim 1, wherein the non-metallic material is disposed substantially only in the arcuate channel.
 - 25 4. The pump rod clamp/blowout preventer of claim 1, wherein the non-metallic material is disposed as one or more bands in the arcuate channel.
 - 30 5. The pump rod clamp/blowout preventer of claim 1, wherein the non-metallic material is selected from the group consisting of elastomers, rubbers, polymers, ceramics, carbides, nitrides, metal oxides, chrysotile materials, metal oxides, and composites containing metal oxides.

6. The pump rod clamp/blowout preventer of claim 5, wherein the non-metallic material is aluminum oxide.

5 7. The pump rod clamp/blowout preventer of claim 1, wherein the non-metallic material is non-releasably affixed to the engaging face by gluing, brazing, form fitting, press fitting, molding, interference fitting, spray coating, or direct chemical deposition.

10 8. The pump rod clamp/blowout preventer of claim 1, wherein the arcuate channel includes one or more pockets for non-releasably receiving a band of the non-metallic material.

15 9. A pump rod clamp/blowout preventer for use in a well, comprising:
a housing comprising:
a longitudinal bore for receiving a pump rod;
at least one of an upper or lower flange for securing the housing to wellhead equipment; and
a pair of opposed radial bores generally perpendicular to,
20 and terminating at the longitudinal bore; and
rams and a actuators received in each of the opposed radial bores, the actuators configured to move the rams between an activated and a non-activated position wherein in the activated position the rams grippingly engage the pump rod with adequate force to support the pump rod and to prevent axial or
25 rotational movement of the pump rod and simultaneously prevent fluids from escaping from the well through the longitudinal bore, the rams comprising:
an engaging face having an arcuate channel situated to receive the pump rod when the ram is the activated position, and
a non-metallic material non-releasably disposed on at least a
30 portion of the engaging face for contacting the pump rod.

10. The pump rod clamp/blowout preventer of claim 9, wherein the actuators comprise stems threadably received within the actuators such that rotation of the stems moves the rams between the activated and non-activated positions.

5

11. The pump rod clamp/blowout preventer of claim 9, wherein the non-metallic material covers the entire engaging face.

12. The pump rod clamp/blowout preventer of claim 9, wherein the non-metallic material is disposed substantially only in the arcuate channel.

10

13. The pump rod clamp/blowout preventer of claim 9, wherein the non-metallic material is disposed as one or more bands in the arcuate channel.

15

14. The pump rod clamp/blowout preventer of claim 9, wherein the non-metallic material is selected from the group consisting of elastomers, rubbers, polymers, ceramics, carbides, nitrides, metal oxides, chrysotile materials, metal oxides, and composites containing metal oxides.

20

15. The pump rod clamp/blowout preventer of claim 14, wherein the non-metallic material is aluminum oxide.

16. The pump rod clamp/blowout preventer of claim 9, wherein the non-metallic material does not provide an electrically insulating barrier between the pump rod and the ram.

25

17. The pump rod clamp/blowout preventer of claim 16, further comprising an electrical contact for maintaining electrical equilibrium between the housing and the pump rod.

30

1/4

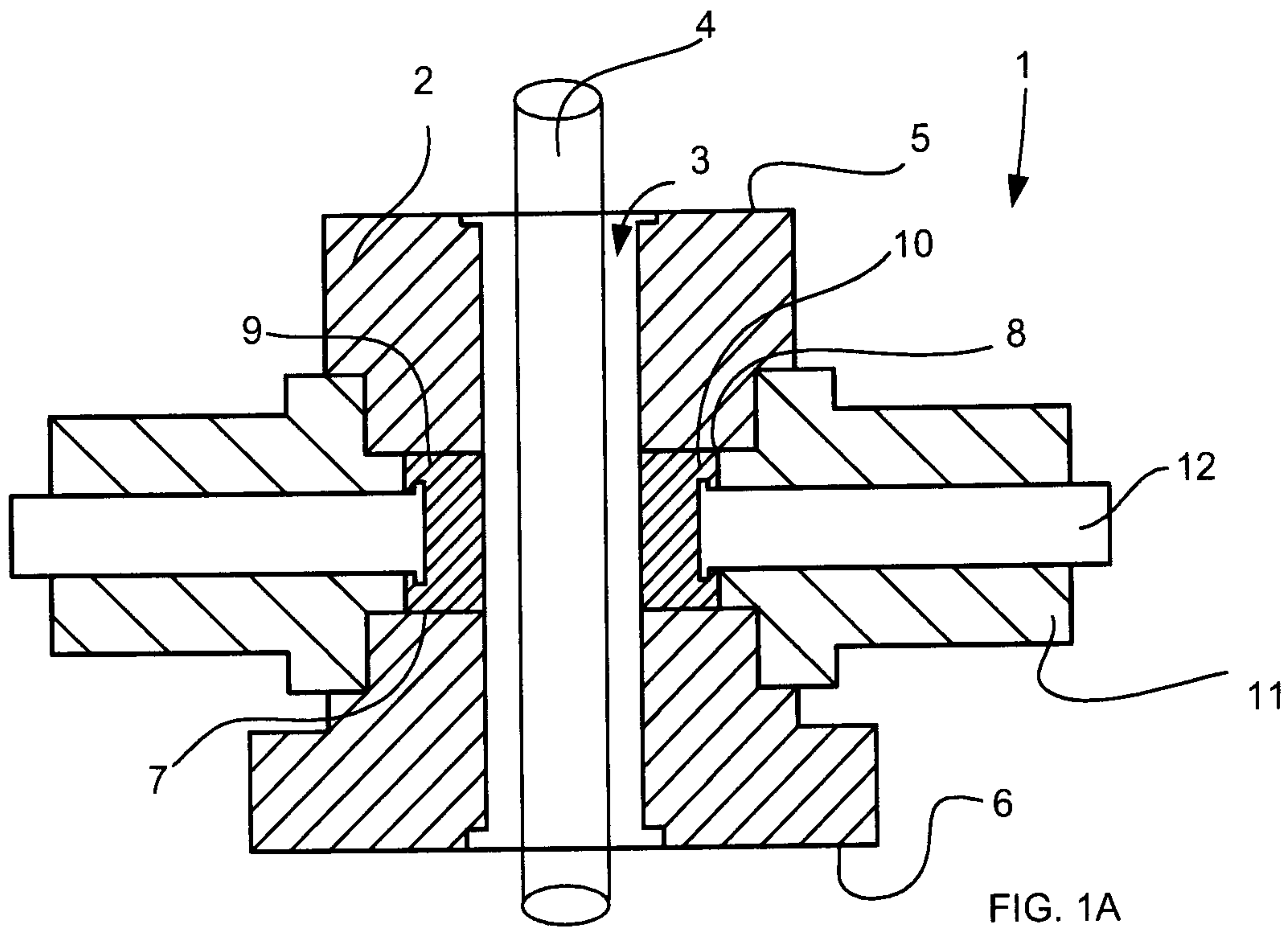

FIG. 1A

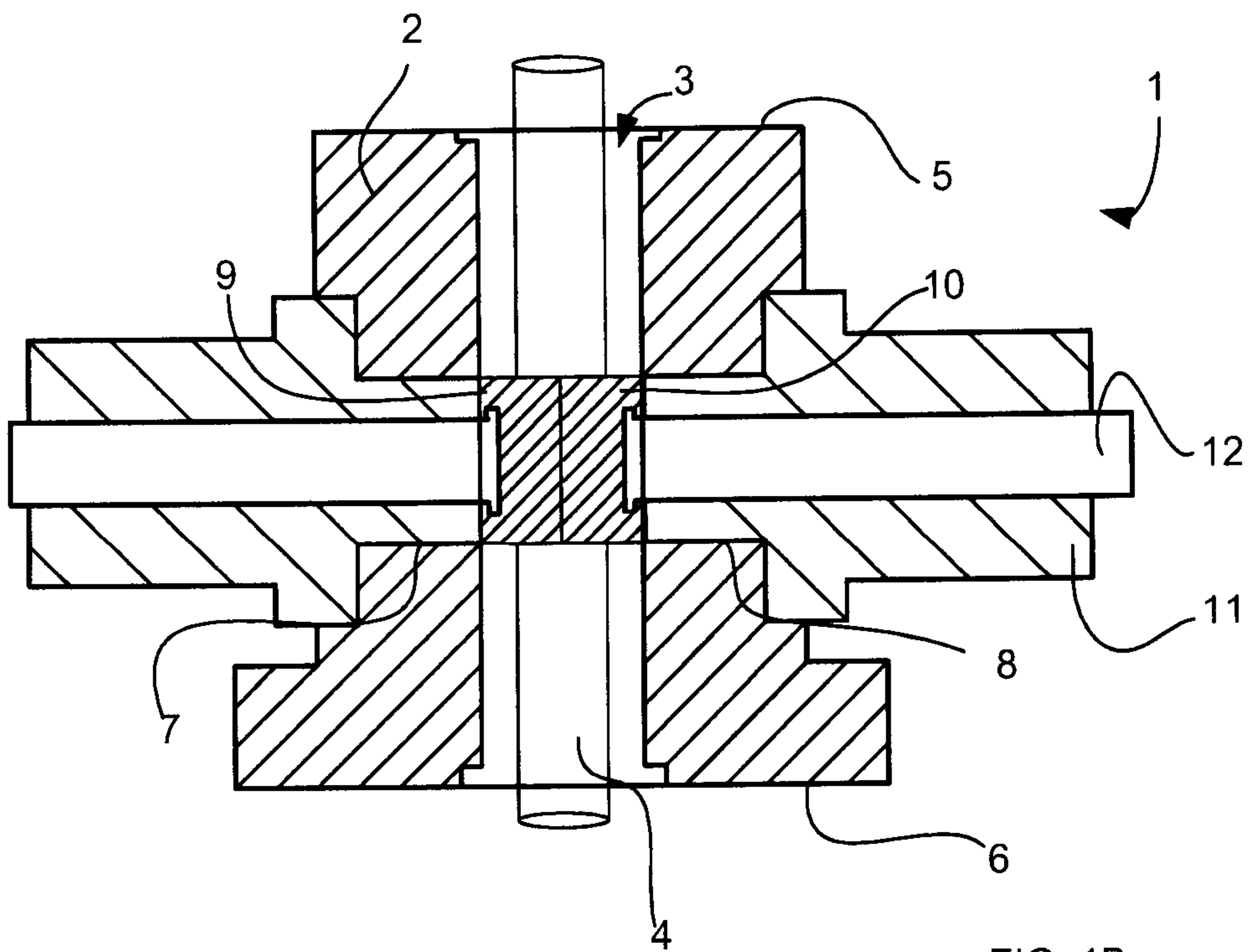

FIG. 1B

2/4

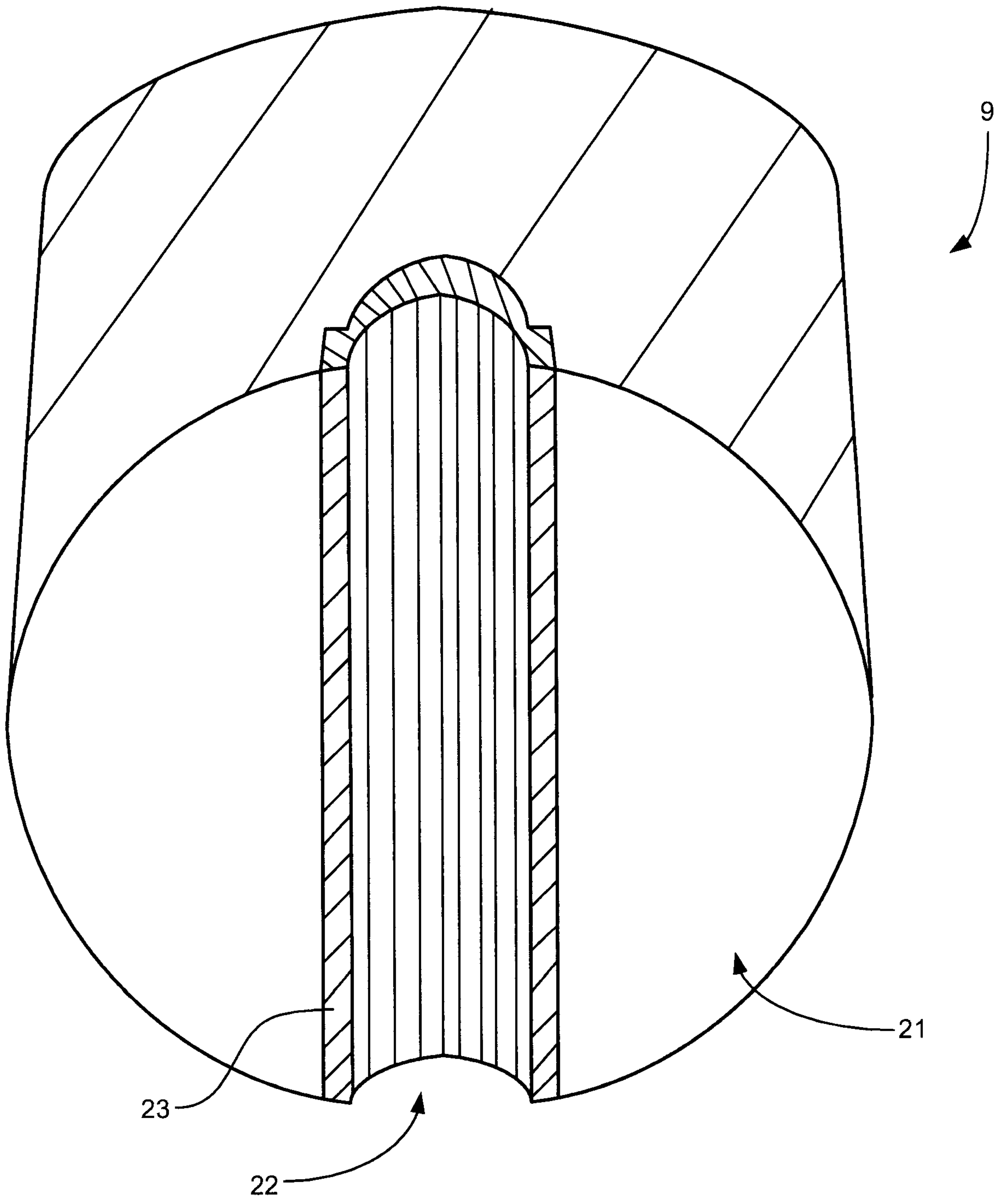
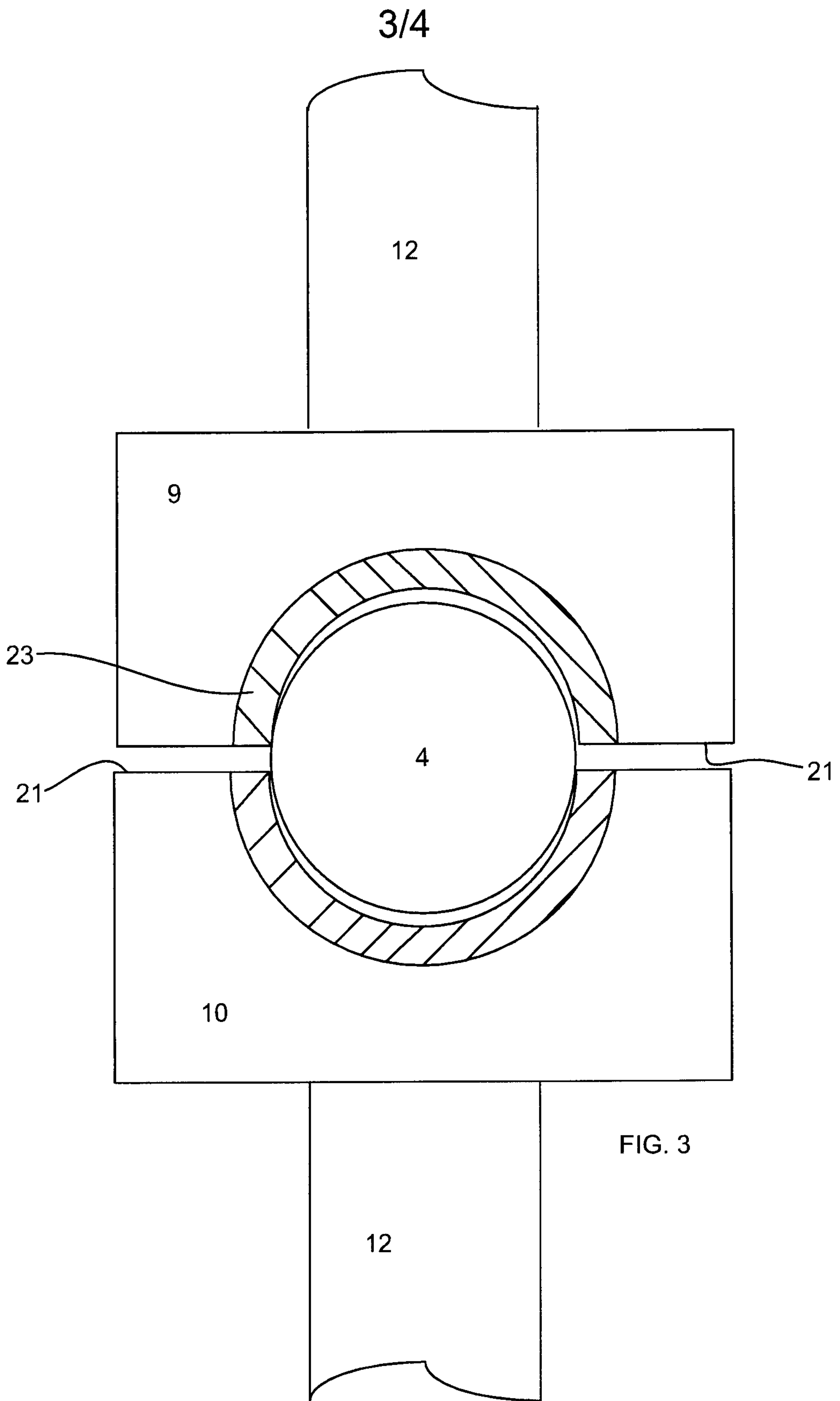

FIG. 2



4/4

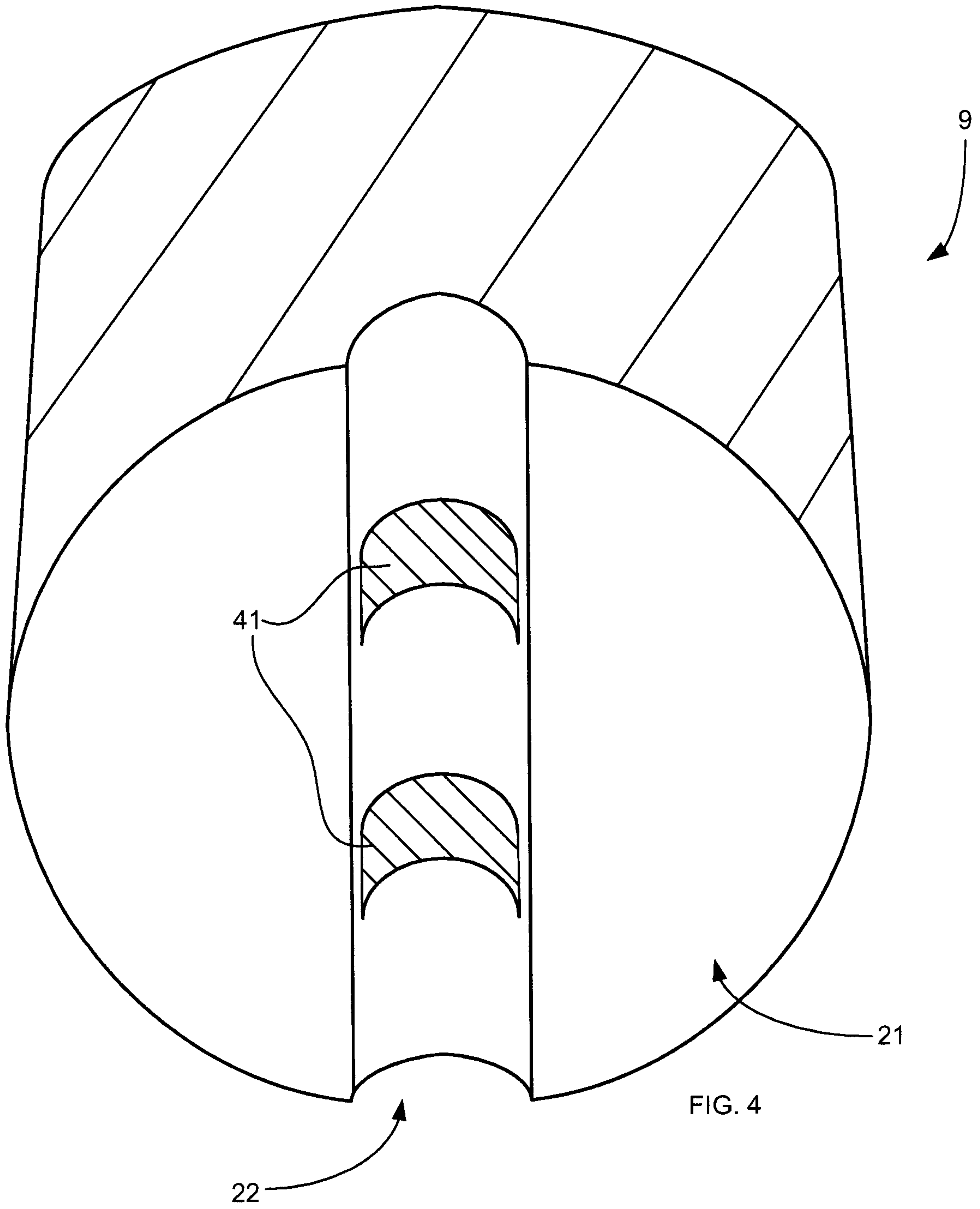

FIG. 4

