

(19) (KR)
(12) (A)

(51) 。 Int. Cl.⁷
B63B 35/44

(11)
(43)

2003-0088136
2003 11 17

(21) 10-2003-7013368

(22) 2003 10 11

2003 10 11

(86) PCT/US2002/10586

(87)

WO 2002/83494

(86) 2002 04 05

(87)

2002 10 24

(30) 09/832,739 2001 04 11 (US)

09/908,877 2001 07 18 (US)

09/921,617 2001 08 03 (US)

(71)

12204

1373

(72)

01770

223

02760

370

02375

489

02062

741

29431

123

29412

41

(74)

:

(54)

/

가 , 'FFCV')
 (flexible fluid containment vessel: , 'FFCV')
 (cargo),
 가 (bulk barge), (tanker)
 가,
 가 가
 가
 150,000
 가
 가
 가
 2,997,973 ; 2,998,973 ; 3,001,501 ; 3,056,373 ; 3,167,103
 가 가
 가 (flexible
 transport bag)
 가
 2,997,973 가
 (streamlined nose)
 가
 (seam)
 (patch work) (stiching)
 3,779,196
 (failure) (seamless)
 가 가
 (simple woven fabric)
 , 1994 11 1 'Press Felt and Method of Manufacture'
 5,360,656 (base
 fabric of press felt)
 1
 (edge joint)
 (welding)(, 1998 2 3 (sewing), (melti
 'Ultrasonic Seaming of Abutting

Strips for Paper Machine Clothing'

5,713,399

)

(tubular structure)
on)가

가, 가

(smooth transiti

(

(stapling))

가

가

(water impermeable)

가

(seal)

가

가

(

, Hawthorne 1961 8 29

)
2,997,973

/

FFCV

FFCV

가

FFCV

FFCV

FFCV

FFCV , 300'

40'

(papermaker's clothing)
(bow) (stern)

(nose) (tail),

40 75

가

(bow)

FFCV

가

가

1

(degree of overlapping)

가

가

가

가

(pleats)

(folds)
가

2

가

(focal points)

(bow)

(tow bar)가 (nose) (fold facilitators) (sprocket) (tooth type arra

3 ngement) 가 가

4

5 가

6

() 3,067,712 3,224,403

1 FFCV

2a, 2b 2c () FFCV

3a 3c FFCV

4a 4h 4h FFCV FFCV

5 (circumferential teeth or radial folds) FFCV

5a 5 (end closure devices)

5b 5a A-A

5c 5a FFCV

6a 6b FFCV

7a 7e FFCV

FFCV(10) (12) (12) () (14, 16) 가 (1 (flexible)

FFCV (to
wing load) FFCV FFCV ,
(towing force) FFCV , FFCV
(uncontrolled sinusoidal oscillations) FFCV (snaking) FFCV . F
FCV
FFCV , FFCV /
(tapered portion) ,
가 (bow portion)
FFCV
, FFCV (12) ,
(12) (knit se
amless) (braided seamless) Albany International
Corp. (large textile loom) (12)
1994 11 1
'Press Felt and Method of Manufacturing It'
5,360,656 (12)
(12) , FFCV(10) (12)
(12)
, 2a 2b FFCV(10) (12) 14 , ((14; co
) 16 (16) 가 가 (pleating) (12) (12)
ne shaped bow) / (12) 가 가 가 2 (18)
가 가 가 40 가 40 가 2
가 40) 5 40 1/20 (5)(2
1 5 95
(18) (18)
(14) (18) (graduation) 2b (18) 가
(20) 가
(18) (12) 가 (18) FFCV가
2c , (18') (4 가) ,
FFCV 가

(12)

FFCV(10) (14) / (16) (20) (18, 18') (22)

(24) FFCV(10) 가 (24) FFCV (24) /

(water tight seal) 가 (24) FFCV (24) (18) (18)

가 3a 3c (12) (3a) FFCV(10)

(3b), FFCV (3c) , FFCV(10) (14) / (16)

4a 4h FFCV (14) / (16) 62 150 가 FFCV(10)

V (14) / (16) (22) 2 () (24)

4a FFCV(10) FFCV (14) 가 L₁ (14) (16)

FFCV(10) L₂ FFCV L₂ L₁ (16) FFCV(10)

4b 4a FFCV(10) 4b 가 L₃

L₃ L₁ L₂ , L₃ L₂ , L₂ L₁

4c FFCV 2 (25) (25) 4 (25) (26), (28) (26) (28) 2 (; 30, 32)

4d (25) (12) (12) L₁, L₂, L₃ 4a

4c 4 (bow point) 4c (28) L₂ (26) L₁ (bow point)

(32) 4c 2 (; 30, 32) L₃ (30)

4 (34-40) (12) 2 (34, 38) (14) , 2 (36, 40) (16) . 4 (, 38') (12) 가 (12)

(30) (32) / (2

5) (12) (blunt boe and stern) (2

ished end connection) (blunt) FFCV (fin

(25)

4d , 4c (25) 4d (12) 4e 4

(42-48) (12) (beaded edge) (25)

4f (25) (fold facilitator; 50-56)

(25)
(50-56)

(58)

(58) 가가 , (snug or tight fitting

) 3 (rolling) 4g

(22) (25)
4h

4d
(initial fold width) 4g 가

FFCV(10) FFCV
가 FFCV(10)

(stiffness)

가 6 가

sealing) (mechanical fastener), (gluing), (

(14) (16) (14)

(16)

5 5b (14) / (16) FFCV(10)
(12) 5 (14)

(62) (60)

(62)가 5a 5b

(62) (69) 1 (68) (70 72) (78)가

(64, 66) (76) (62) (74)

(80) (74) (82) (74) (78)가 (80)

(78) (74) (80) (74) (84)가

5 (62) (12) 가

가 (62)

5c , , (gathering) .
 , 가 가 (14)가 .
) 6a 6b . 6a FFCV(10) (,
 (100) (24)가 FFCV (102)
 (104) U . U (10
 4) (104) (100) (106) . U (,
 (108) , FFCV (112) ((110)) .
 (24) (112) (104)가 .
 6b , (104) FFCV (100)
 , (100) (12) (full circumference) .
 FFCV(10) FFCV (,
 single piece) , (woven, knitted or braided) FFCV (,
 , FFCV (seam) .
 FFCV ,
 , 31 (double endless weaving tec
 hniques) 124 .
 , 가 가 ,
 (knitting needles) (dopping out) .
 , 가 가 ,
 (large tubular braided s
 tructures) 가 FFCV ,
 (triaxial braiding approach) ,
 , (tied off) (main structure) .
 , 가 (draw in) 가 (variable pitch reed) .
 가 가 가 .
 , (yarn load) . FFCV
 가 가 가 , FFCV
 가 (가) (12) ,
 가 가 (12)
 (sewing), (gluing), (thermal bonding),

(mechanical fastening)()

(12)

FFCV가

7a 7e , FFCV(10) (12) 7a

(12)가 (14 16) ()

(120) (122) ()

(120) (124)가 (12) (122)

(124) (7c). (7b). (126)()

(124)가 (126)

(126) (7d).

(126)

(24) ()

7e). (24) (126) (126)

) FFCV FFCV FFCV ()

가

(FFCV) 가

(57)

1.

가 / ,

1 (elongated flexible tubular structure);

;

;

;

2

가

가 1

2.

1 ,

1 3. , , 2

1 4. , .

1 5. , .

1 6. 가 / , ;

;
;
;

6 7. , .

1 8. 가 / , ;

;
;
;

2 , , 가 1

9.

- 8 , .
- 10. 8 , , , , , .
- 11. 8 , , .
- 12. 11 , .
- 13. 8 , .
- 14. 11 , .
- 15. 8 , .
- 16. 8 , .
- 17. , 가 / , , 1 ; ; ; , , , 가 1 2 .
- 18. 17 , .
- 19.

18 , 2 , 가 , 1 2 1

20. 19 , 2

21. 20 , .

22. 17 , .

23. 가 / , 1 ;

;

,

2 , 가 가 1 .

24. 23 , .

25. 24 , 2 , 가 , 1 2 1

26. 25 , .

27. 26 , .

28. 23 , .

29.

가 /

1 ;

;

;

;

2 , , 1

29 30. 가

29 31. 가 (draw

ing in)

29 32. (knitting needles)

(dropping)

29 33.

29 34.

29 35.

29 36.

29 37. 가 /

1 ;

;

;

;

,

1

2

38.

37

39.

37

40.

37

41.

가

/

1

1

2

42.

41

43.

41

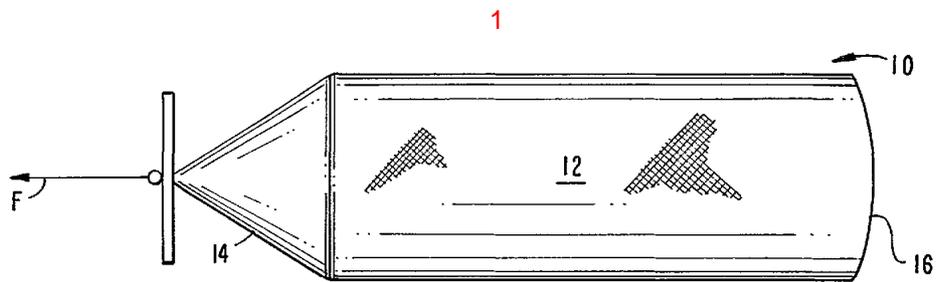

2a

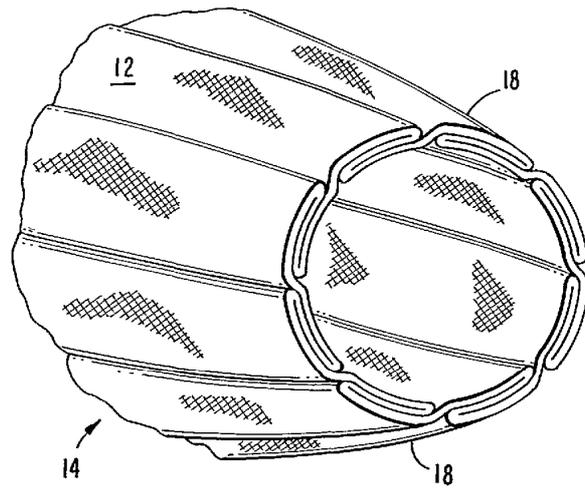

2b

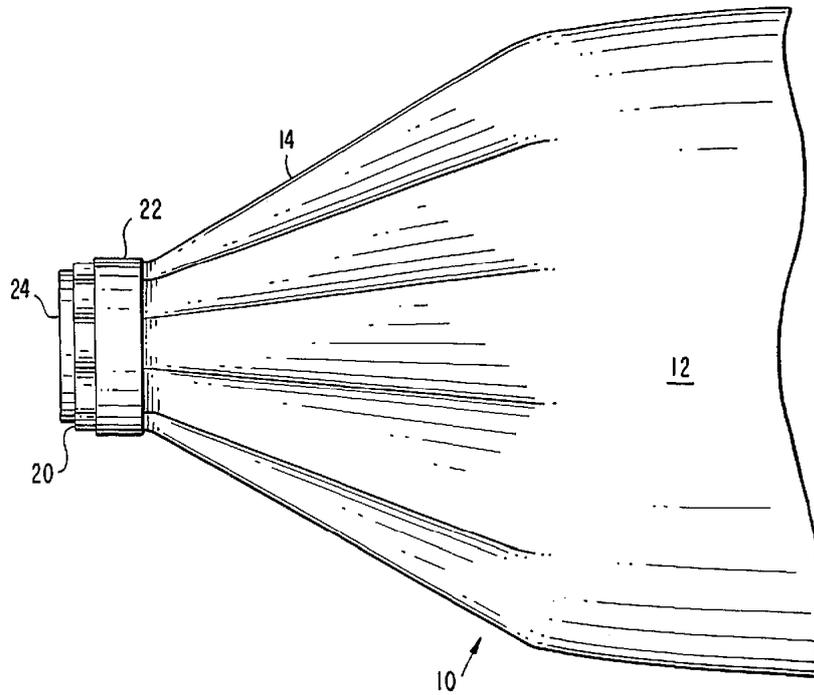

2c

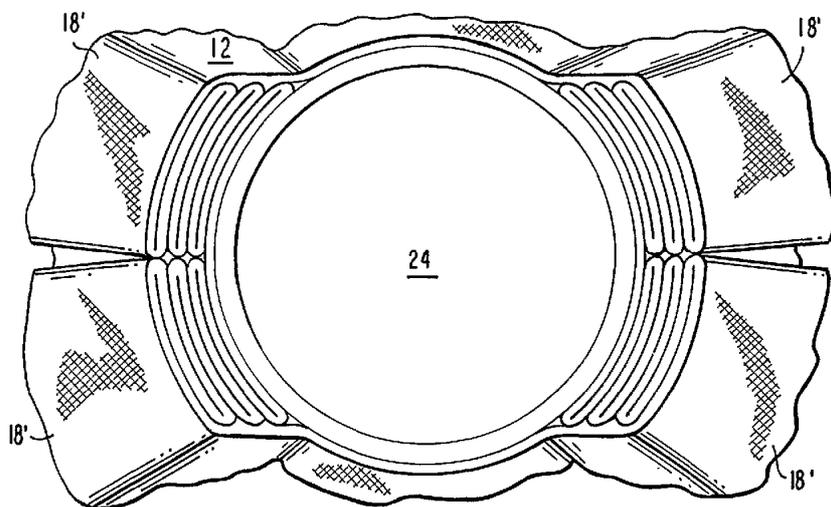

3a

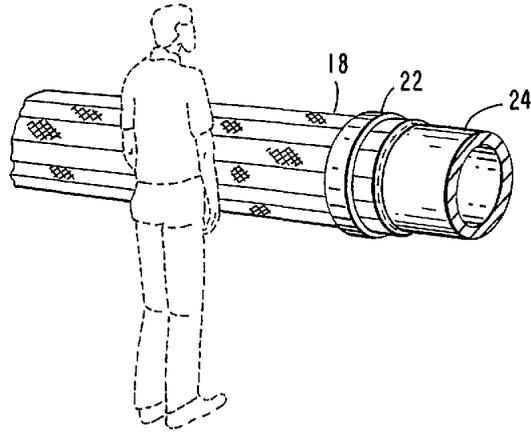

3b

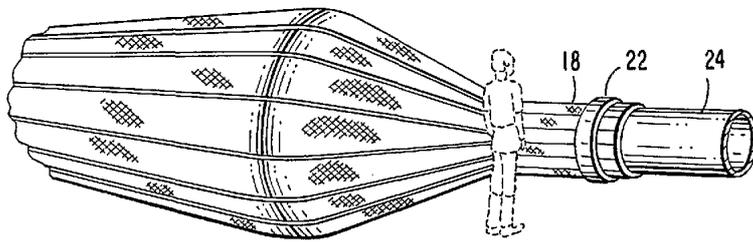

3c

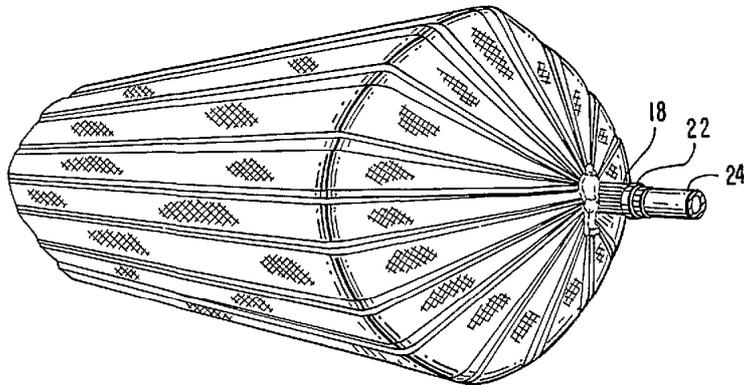

4a

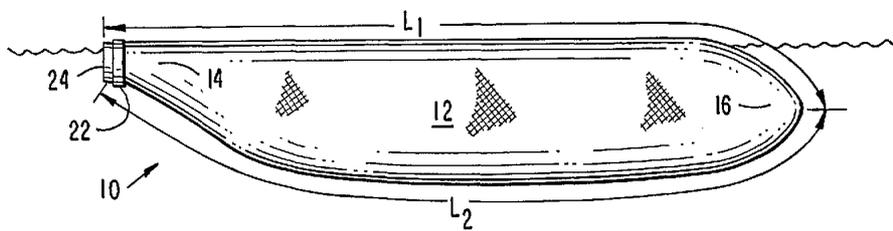

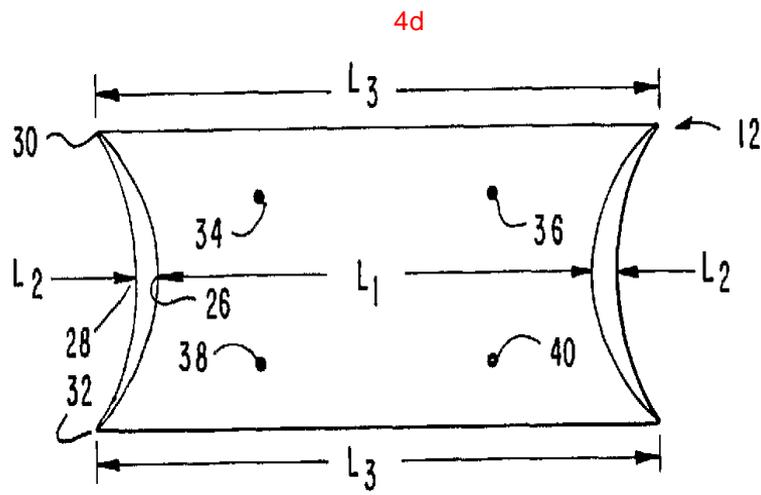
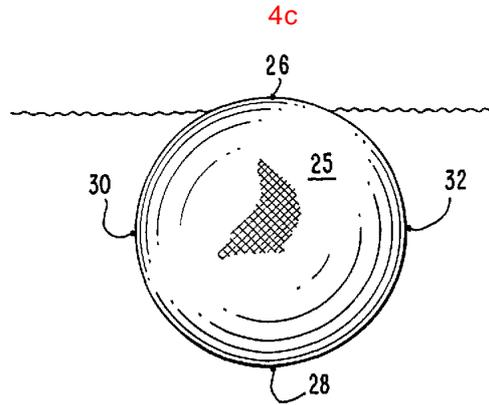
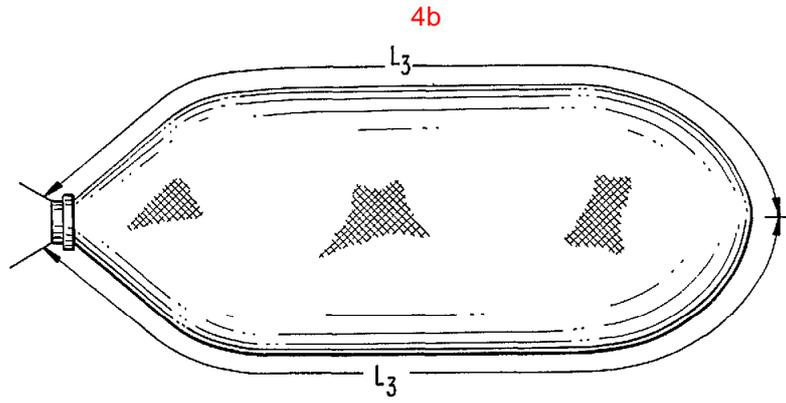

4e

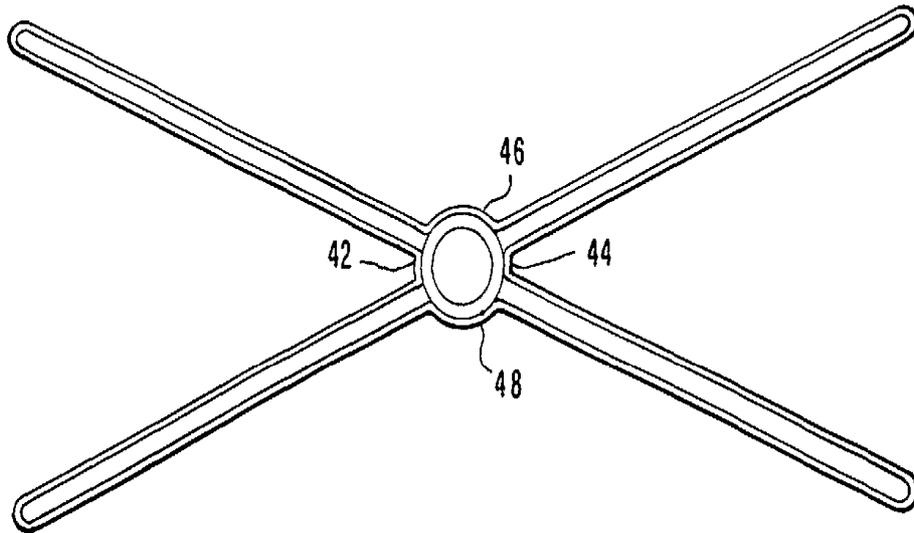

4f

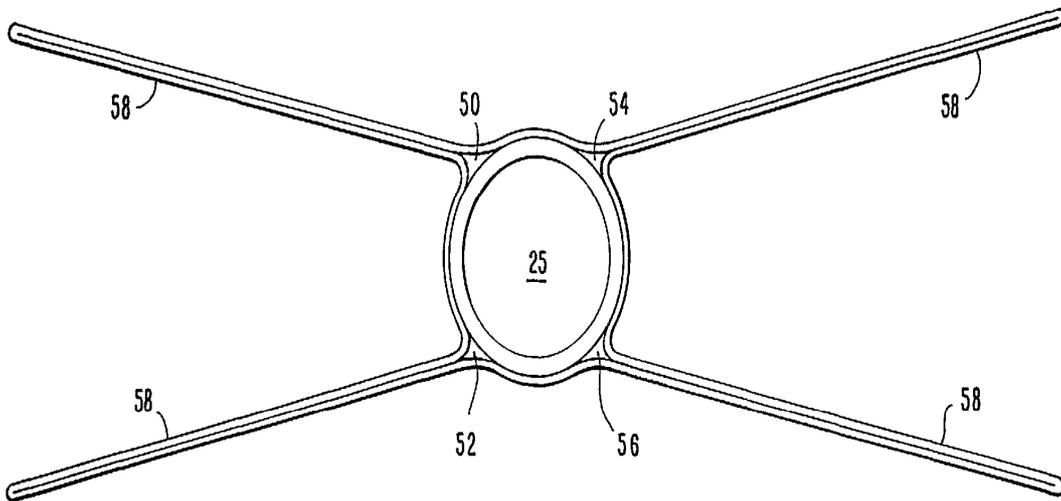

4g

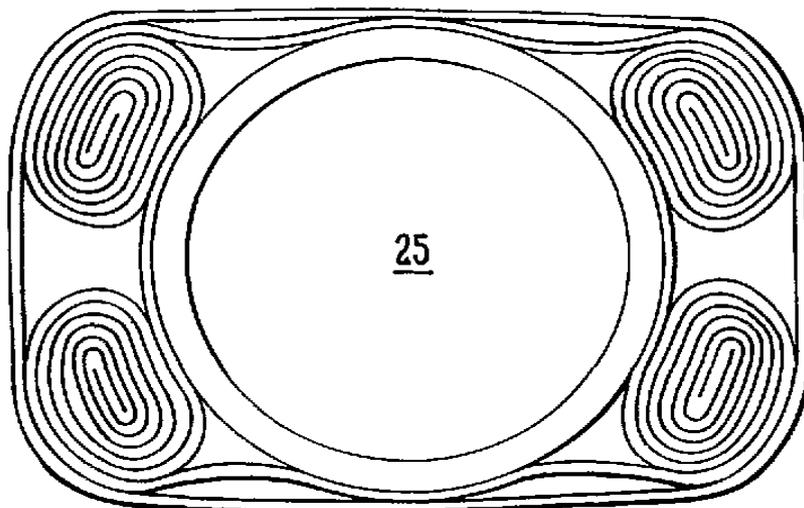

4h

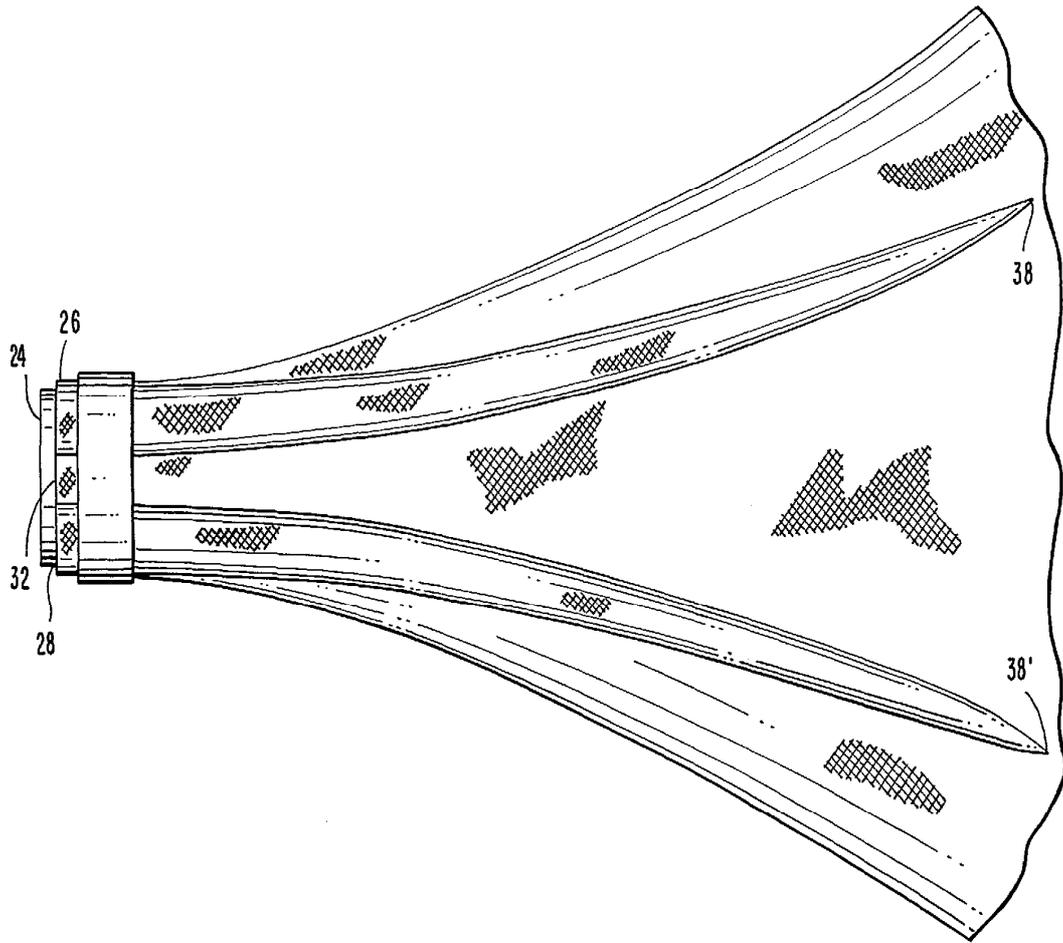

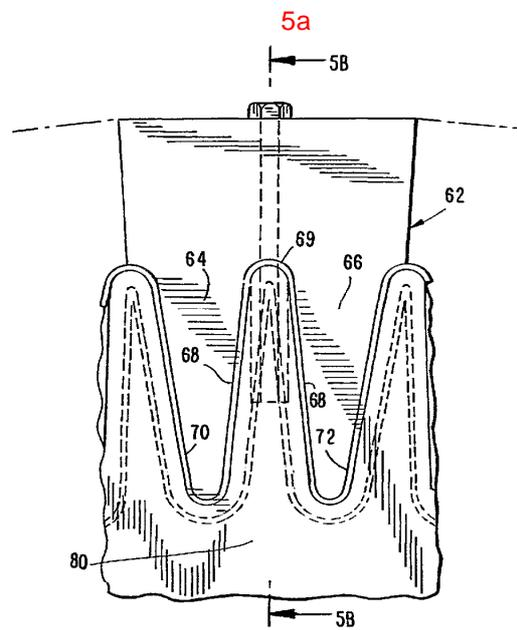
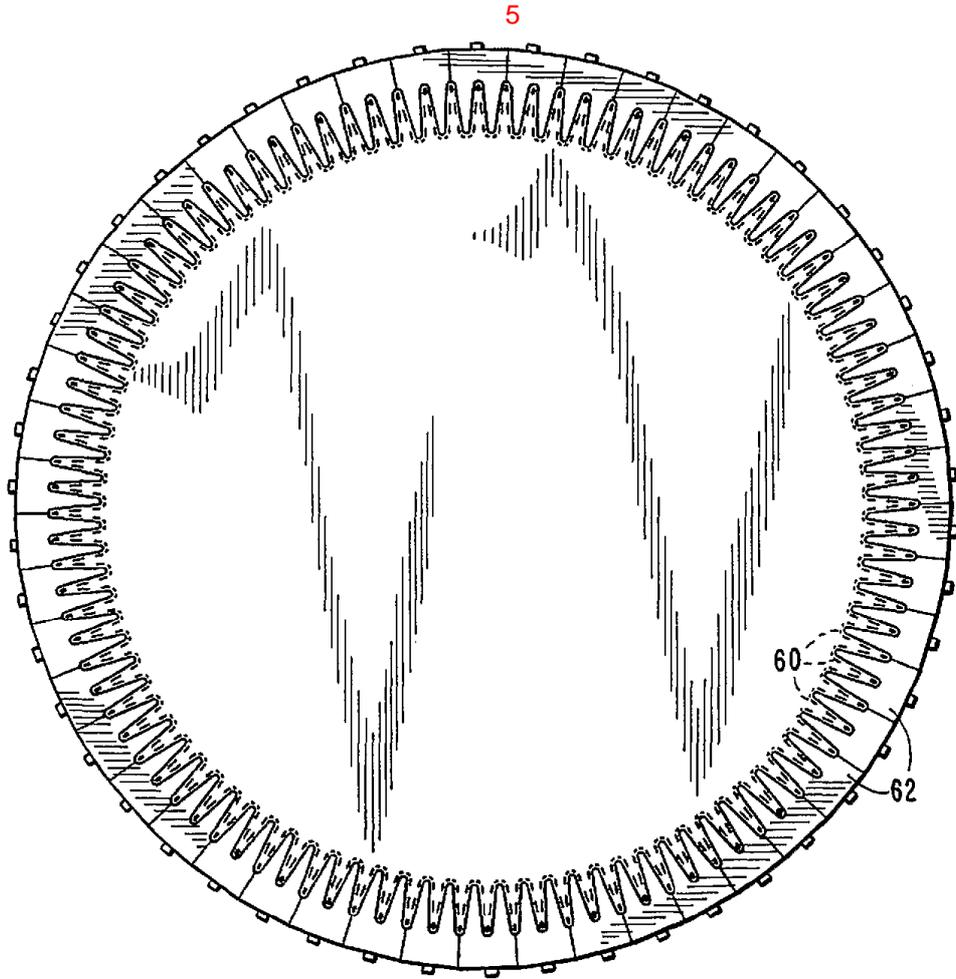

5b

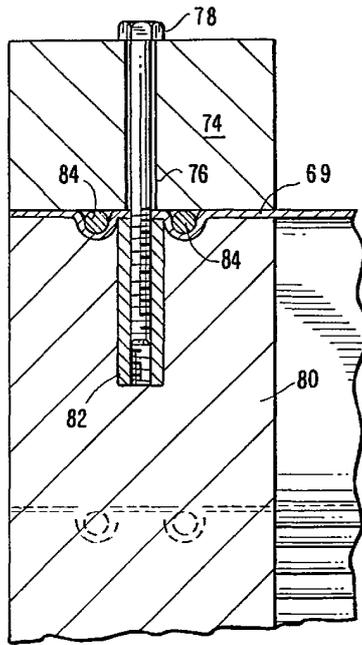

5c

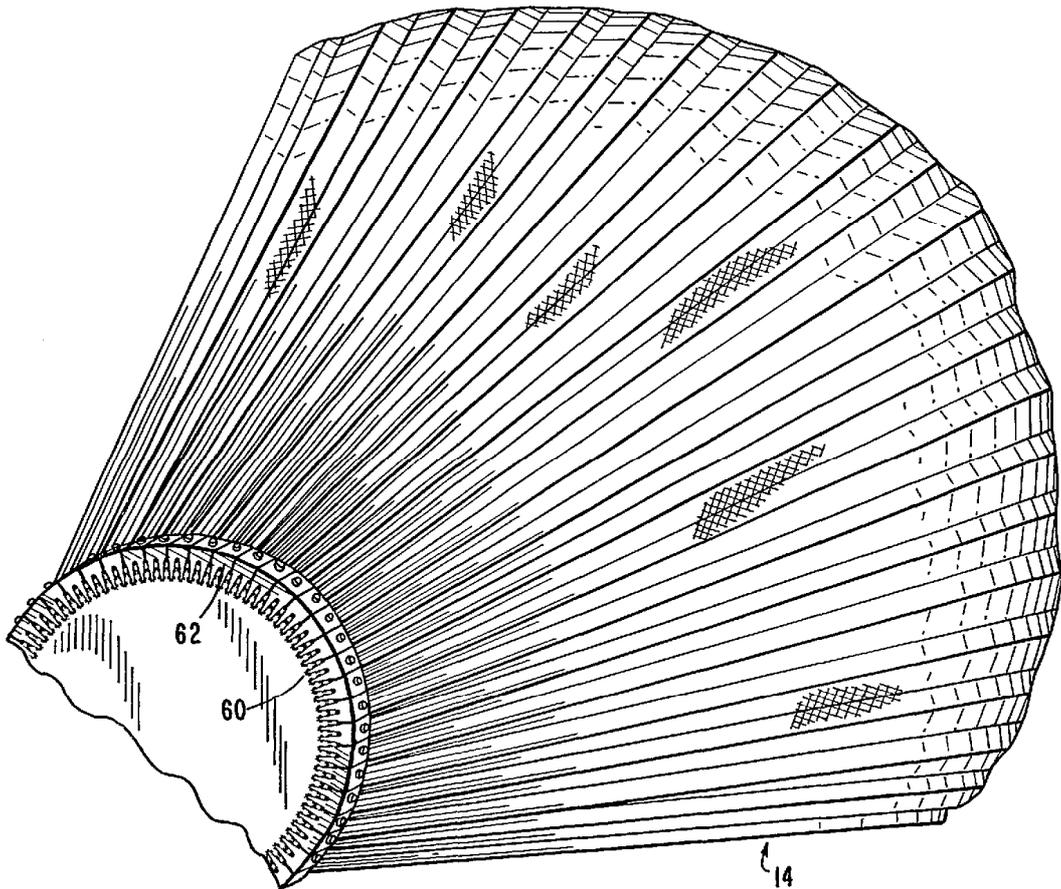

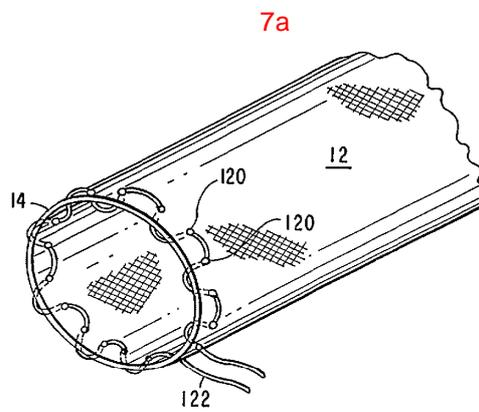
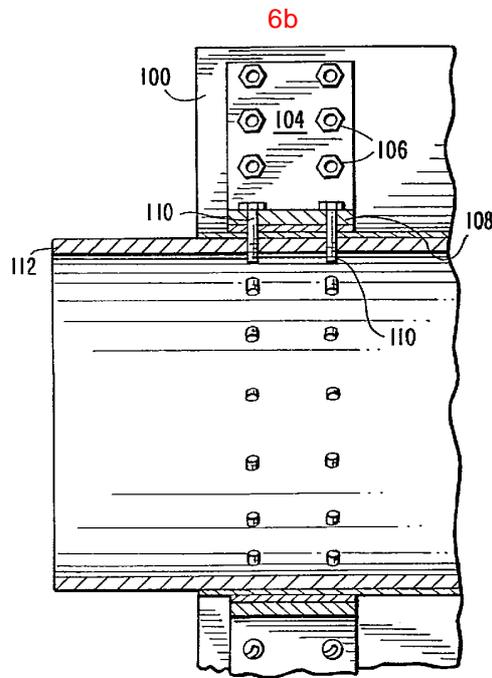
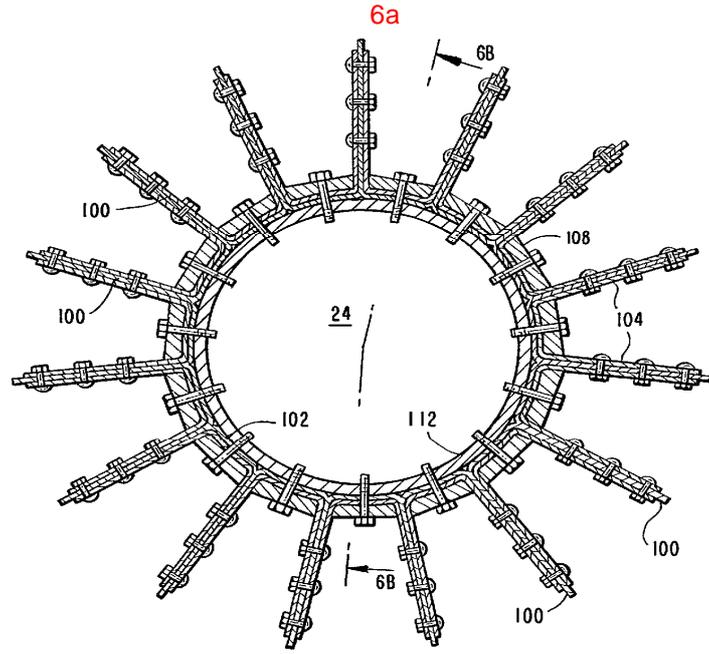

7b

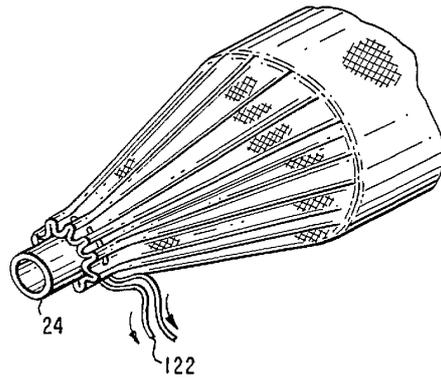

7c

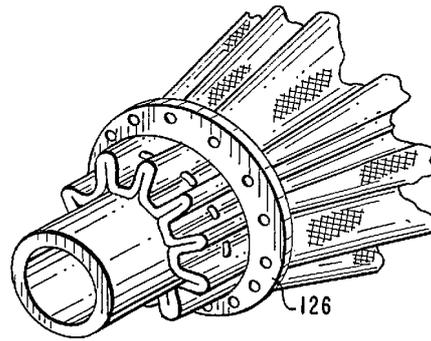

7d

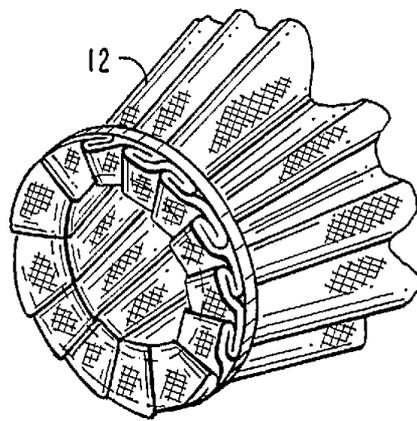

7e

