

No. 815,003.

PATENTED MAR. 13, 1906.

J. P. BIRD.
MACHINE FOR SECURING FLIES TO BOXES.

APPLICATION FILED JULY 9, 1900.

6 SHEETS—SHEET 1.

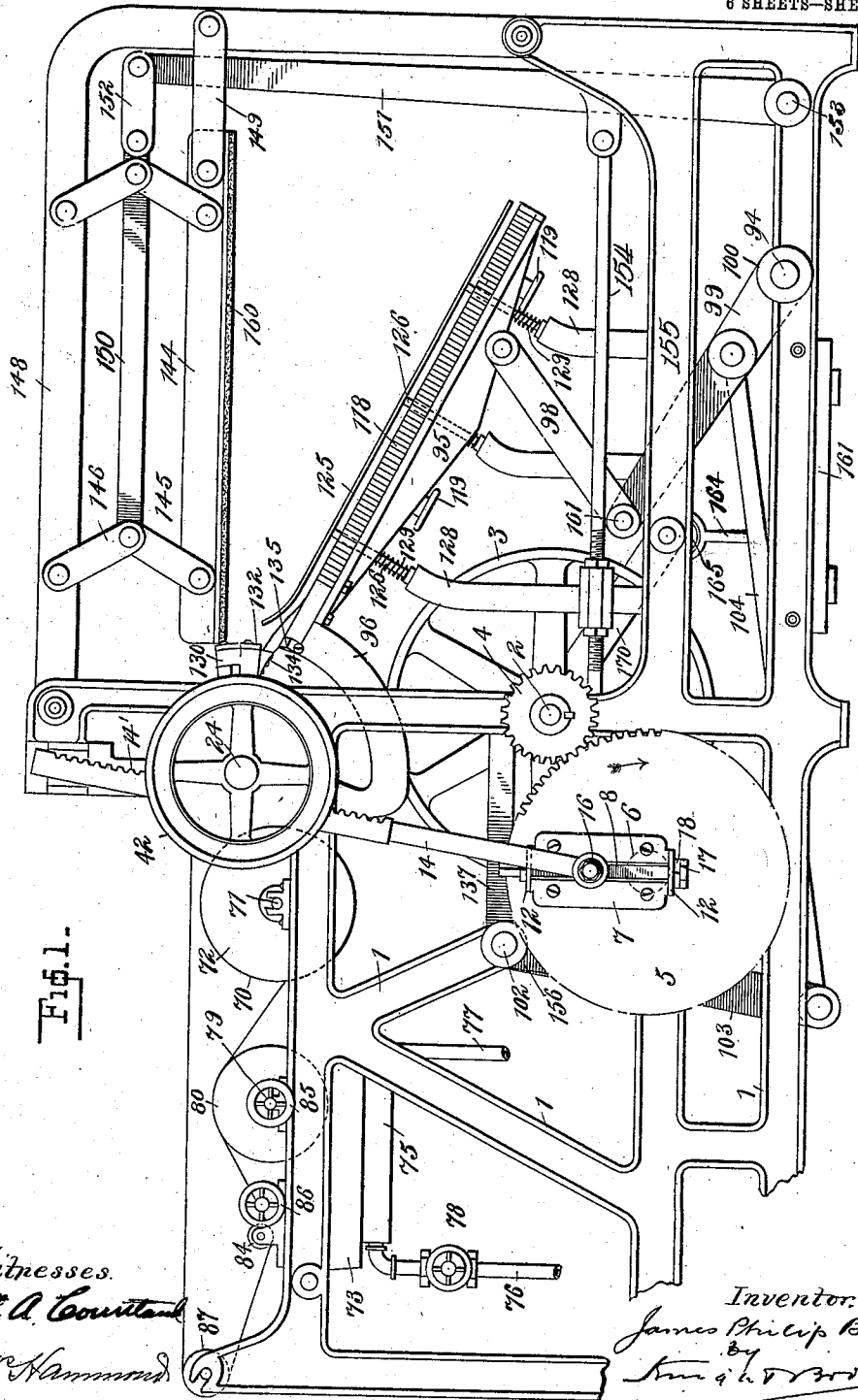

Fig. 1.

Witnesses.
Wm A. Courtland
W. T. Hammond

Inventor:
James Philip Bird
Smith & Co
Atty.

No. 815,003.

PATENTED MAR. 13, 1906.

J. P. BIRD.

MACHINE FOR SECURING FLIES TO BOXES.

APPLICATION FILED JULY 9, 1900.

6 SHEETS—SHEET 2.

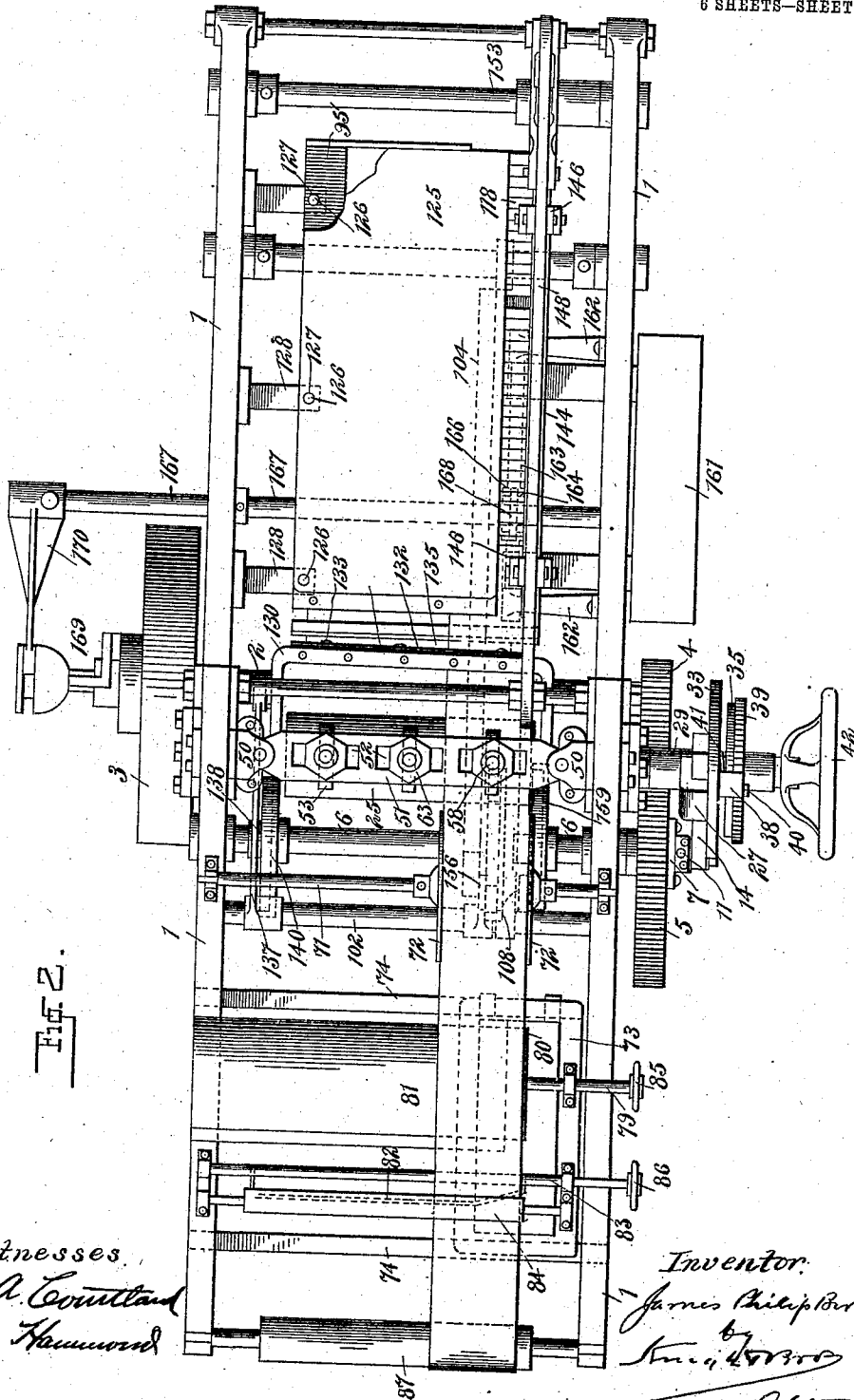

FIG. 2.

Witnesses,
W. A. Courtland
W. P. Hammond

Inventor,
James Philip Bird
 by
Amos W. ...
 Atty.

No. 815,003.

PATENTED MAR. 13, 1906.

J. P. BIRD.
MACHINE FOR SECURING FLIES TO BOXES.

APPLICATION FILED JULY 9, 1900.

6 SHEETS—SHEET 3.

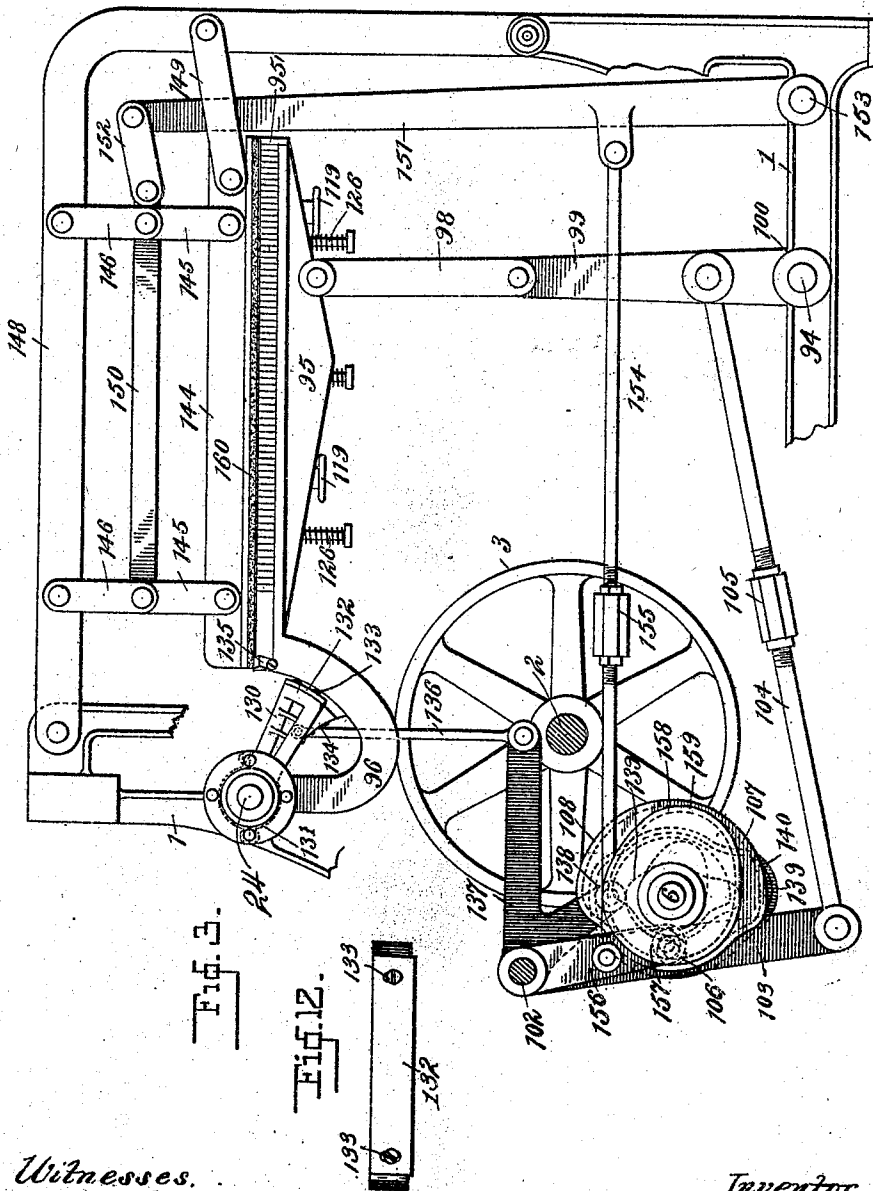

FIG. 11.

FIG. 12.

Witnesses.
W. A. Courtland
W. Hammond

Inventor.
James Philip Bird
By *[Signature]*
Att'y.

J. P. BIRD,
MACHINE FOR SECURING FLIES TO BOXES.

APPLICATION FILED JULY 9, 1900.

6 SHEETS—SHEET 4.

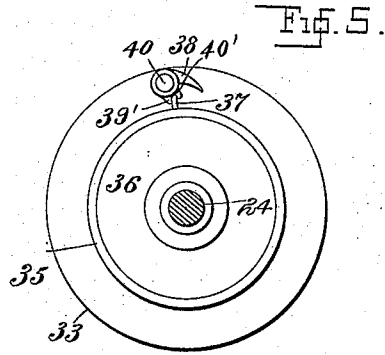
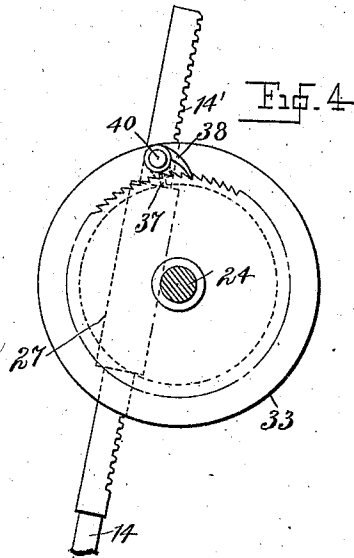

Fig. 4.

Fig. 5.

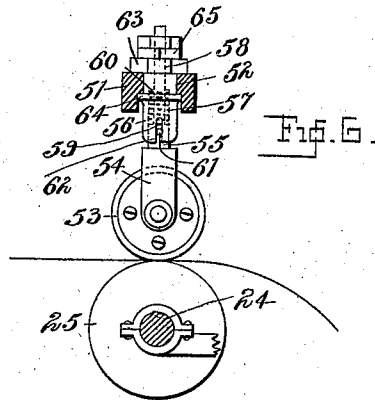
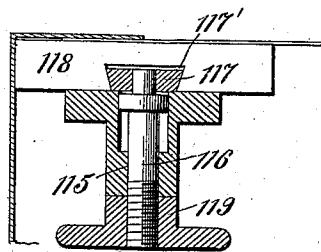

Fig. 6.

Fig. 7.

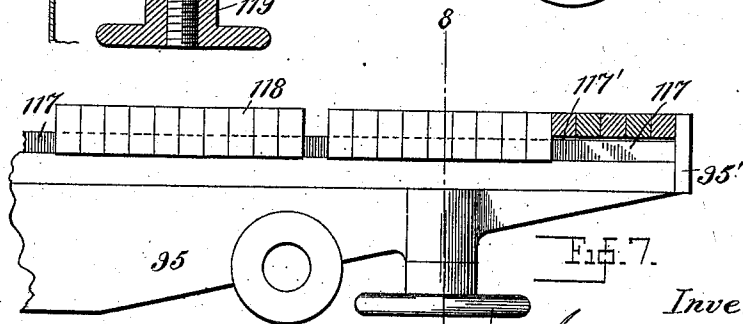

Fig. 8.

Witnesses,
W. A. Courtland
W. P. Hammond

Inventor,
J. P. Bird
 by
[Signature]
 Attys.

No. 815,003.

PATENTED MAR. 13, 1906.

J. P. BIRD.
MACHINE FOR SECURING FLIES TO BOXES.

APPLICATION FILED JULY 9, 1900.

6 SHEETS—SHEET 5.

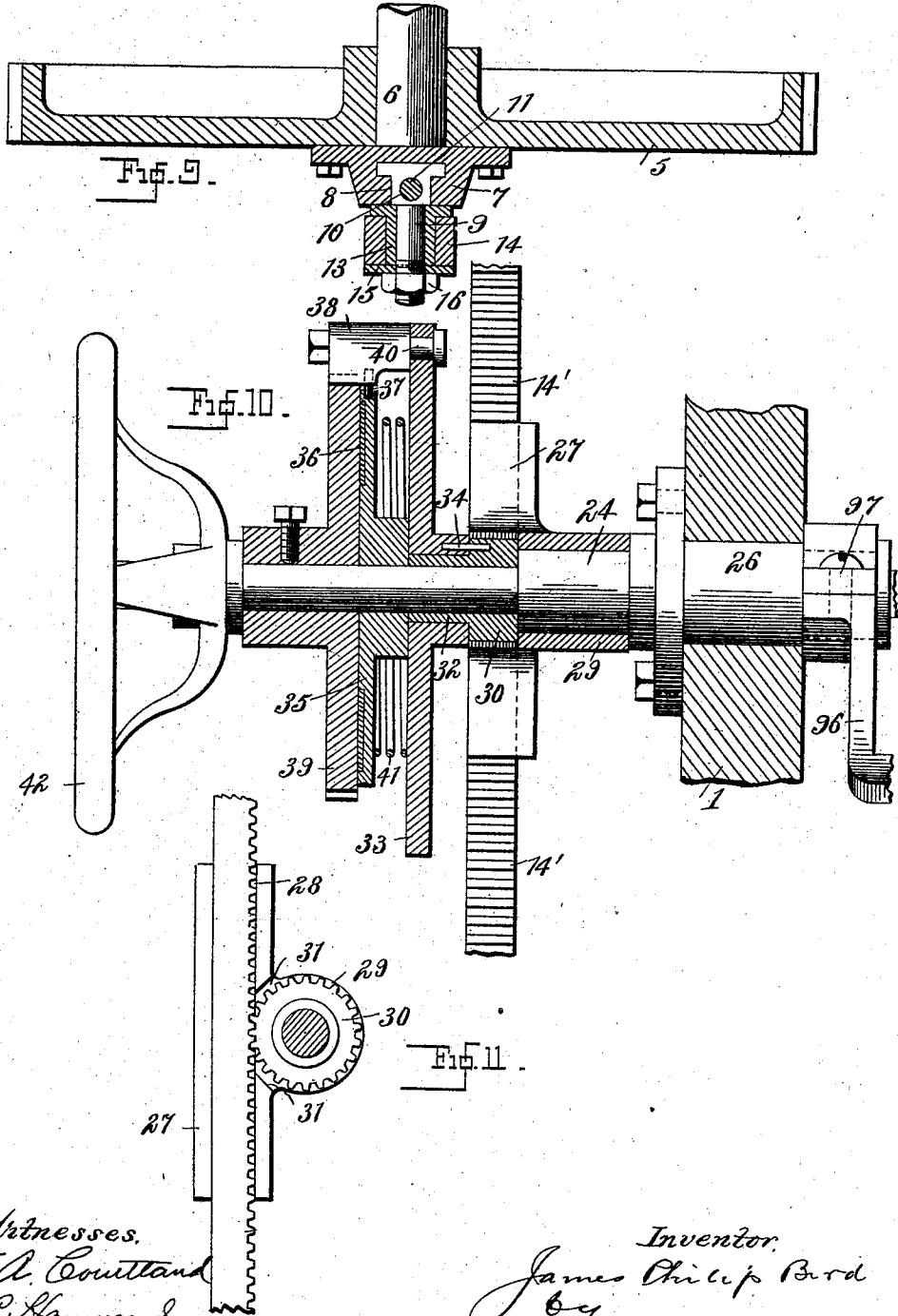

Witnesses,
Wm. A. Courtland
A. P. Hammond

Inventor,
James Philip Bird
By
[Signature]
Attys.

No. 815,003.

PATENTED MAR. 13, 1906.

J. P. BIRD.

MACHINE FOR SECURING FLIES TO BOXES.

APPLICATION FILED JULY 9, 1900.

6 SHEETS—SHEET 6.

Fig. 13.

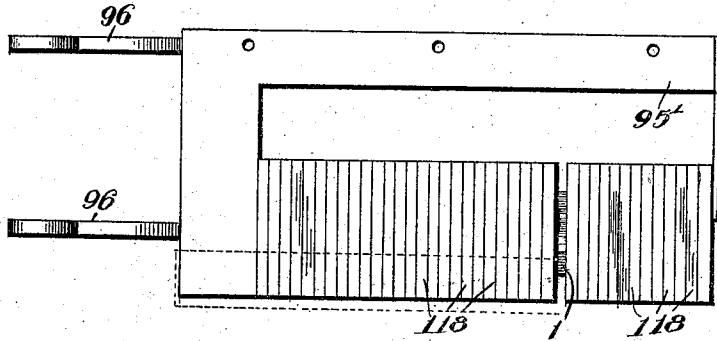
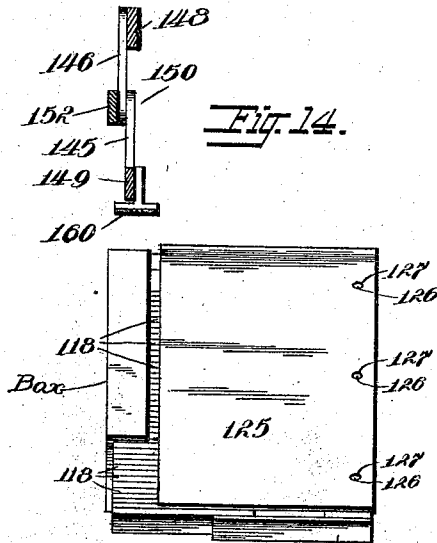

Fig. 14.



Witnesses
 Milton Kenoir
 Walter Estabrook

95⁺
 James Philip Bird, Inventor
 by Rufus B. Fowler
 his Attorney

UNITED STATES PATENT OFFICE.

JAMES PHILIP BIRD, OF WORCESTER, MASSACHUSETTS.

MACHINE FOR SECURING FLIES TO BOXES.

No. 815,003.

Specification of Letters Patent.

Patented March 13, 1906.

Application filed July 9, 1900. Serial No. 22,980.

To all whom it may concern:

Be it known that I, JAMES PHILIP BIRD, a citizen of the United States, residing at Worcester, in the county of Worcester, State of Massachusetts, (post-office address Worcester, Massachusetts,) have invented certain new and useful Improvements in Machines for Securing Flies to Boxes, of which the following is a specification.

This invention relates to machines for securing flies to boxes, and is of the kind wherein a continuous strip of paper is gummed, fed onto the box-receiving table, cut into the desired lengths, and secured to the box; and the object of the invention is to simplify the method of securing flies to boxes and obviate the present difficulties arising in this class of machines by completing the entire process of gumming, cutting, and pasting with one machine. In order to accomplish this, a continuous strip of paper of the style selected is fed from a roll over a glue-distributing wheel, through an intermittently-operated feed-roll and feed-wheels, and thence down onto an oscillating box-receiving table, after which it is cut off and the box-receiving table brought into contact with an intermittently-operated presser-bar when the fly is secured to the box. The above-recited sequential movements are produced by having the feed-roll intermittently operated by a rack-bar, pinion, ratchet-wheel, and intermediate connections and a series of properly-arranged cams on an auxiliary shaft driven by the main shaft and operating, through intermediate mechanism, the cutting-knife, the oscillating box-receiving table, and the presser-bar for each complete operation of the machine. Heretofore in this class of machines it has been necessary to previously prepare the flies before they were placed upon the machine, usually by cutting them into the desired lengths, gumming, and putting them into stacks or pads before placing them on the table of the machine. Each fly is then dampened, the box placed in position on the fly, and pressure brought to bear by the machine, so that the fly is secured to the box; but in removing the adhered fly from the stack or pad it was frequently torn or dislodged others, particularly so where "laces" were used. This process is a very slow one and tends to delay the completion of the box more than any other department wherein flies are used in box-making. By employing a continuous strip of paper freshly gummed and immediately fed to

the box-receiving table, cut off, and secured to the box a great saving of time is effected and a uniform condition of the pasted flies is always preserved.

This invention consists of certain new and novel features of construction and operation, which will be fully and clearly set forth in the following specification and the essential points of merit pointed out in the claims.

In the accompanying drawings, forming a part of the specification, Figure 1 is a side elevation of the machine, the parts being shown as ready to receive a box. Fig. 2 is a plan view. Fig. 3 is a partial side elevation with parts of the side frame broken away to show the operating-cams, the position of the parts being the extreme opposite of that shown in Fig. 1. Fig. 4 is a detail elevation of the rack-bar, pinion, and ratchet-wheel for operating the feed-roll. Fig. 5 is a reverse elevation of a part of the same. Fig. 6 shows the feed-roll and one of the feed-wheels. Fig. 7 is a detail side view, partially in section, of a portion of the box-receiving table and sliding blocks. Fig. 8 is a vertical section on the line 8 8, Fig. 7. Fig. 9 is a detail horizontal section of the cam, driving-gear, and parts for adjusting the throw of the rack-bar. Fig. 10 is a detail view, partially in section, of the feeding mechanism. Fig. 11 is a side view of the rack-bar holder, rack, and pinion. Fig. 12 is a detail view of the knife. Fig. 13 is a top plan view of the table 95 and gooseneck 96; and Fig. 14 is a detail end view of the table, the fly-holding plate, and the presser-bar, the parts being open, as shown in Fig. 1.

Similar numerals of reference indicate like parts throughout the specification and the various views of the drawings.

In the practical application and construction of the machine, 1 1 are the side frames supporting the various working parts, the driving-shaft 2 being journaled therein and having on its respective ends the driving-pulley 3 and on the operator's side of the machine a pinion 4, meshing with and driving a gear-wheel 5, secured to the auxiliary shaft 6. Bolted to the outer face of the gear-wheel 5 is a block 7, provided with a longitudinal dovetailed or beaded groove 8, Fig. 9, adapted to receive and retain a stud 9, having a corresponding dovetailed or beaded head, through which is a threaded opening 10 to receive the adjusting-bolt 11, extending along the groove 8 and held in position by caps 12, fastened to each end of the block. Fitted on the stud 9

and resting against the head thereof is a collar 13, which receives one end of the rack-bar 14 and is held in position by a washer 15 and nut 16, the rack-bar being free to turn on the bushing when the gear-wheel revolves. When it is desired to lengthen or shorten the stroke of the rack-bar 14 to change the feed for different lengths of flies for the different sizes of boxes, the lock-nuts 17 and 18 are released, the adjusting-bolt turned in either direction, which will move the stud 9 toward or from the axis of the gear-wheel to the desired position, when the lock-nuts are tightened and the parts will again be held rigidly together.

A shaft 24 carries the feed-roll 25 and is journaled in bearings 26, bolted to and extending through the side frames, said shaft having a pinion 30 loosely mounted thereon, engaging the rack 14' on the rack-bar 14. Freely supported on the end of the bearing 26 of shaft 24 between the pinion 30 and the side frame by means of a collar-bearing 29 is a block 27, having a longitudinal groove 28 therein, in which the rack-bar is guided and held in engagement with the pinion as it moves up and down with each revolution of the gear-wheel 5, and has a cut-away portion 31 to permit the rack-bar to mesh with the pinion on shaft 24 and is also free to move in response to the various planes assumed by the rack-bar during its operation. Mounted on the reduced end of the pinion 30 is a pawl-carrying disk 33, said disk having on the hub thereof a pin 34, engaging in a corresponding hole in the pinion and by means of which they are locked together and move as one piece. A disk 35 is loosely carried on the shaft 24 just in front of the pawl-carrying disk, the outer face being covered with some frictional material 36, such as leather or the like, and is held in frictional contact with the inner face of a ratchet-wheel 39 by a spring 41, surrounding the shaft 24 and pressing against the pawl-carrying disk 35. The pawl-carrying disk has a pawl 38 pivoted thereto at 40, said pawl having a short under projection 39', with a slot 40' therein that is engaged by a fixed pin 37 on the friction-disk, acting to throw the pawl into engagement with the ratchet-wheel immediately the pawl-carrying disk is moved. The ratchet-wheel 39 is fixed to the outer end of the feed-roll shaft 24 in front of and in contact with the friction-disk 35 and engages the pawl on the pawl-carrying disk and directly operates the feed-roll 25 by means of the above-described connections with the rack-bar. On the end of shaft 24 is a hand-wheel 42 for manually operating the feed-roll when it is so desired. Thus it will be seen that when the gear-wheel 5 revolves it will operate the rack-bar to rotate the pinion 30 on the feed-roll shaft 24, which in turn operates the pawl-carrying disk, and the pawl on said disk will be thrown down into engagement with the ratchet-wheel by the pin on

the friction-disk, said disk not moving until the pawl engages the ratchet, when the pawl-carrying disk, the friction-disk, and the ratchet-wheel will move together and rotate the feed-roll 25 the desired distance, whereupon the rack-bar will be drawn down and the pinion 30, pawl-carrying disk, and friction-disk will be returned to their initial positions ready for another operation to progress the feed-roll. When the pawl-carrying disk is rotated backward by the rack and pinion, the frictional disk does not immediately respond, and the pin 37 thereon will lift the pawl out of engagement with the ratchet-wheel and then move back with the pawl-carrying disk.

Bolted to each inner face of the side frames above the feed-roll 25 are two brackets 50, to which are secured, by means of bolts, a cross-bar 51, that supports the feed-wheels above the feed-roll, and they may be adjusted laterally on said cross-bar so that they do not come in contact with the gummed edge of the paper. The feed-wheels 53 are held in frictional contact with the feed-roll and are rubber-faced and carried by brackets 54, Fig. 6, having upwardly-projecting studs 55, that bear in sleeves 56, said sleeves having enlarged openings in their lower ends, in which spiral springs 57 are lodged and surround the reduced ends 58 of the studs 55, said springs bearing against the shoulders on the studs and the shoulders of the sleeves and tending to force the feed-wheels down against the feed-roll. Extending through the reduced portions of the studs 55 are pins 61, that engage in slots 62 in the sides of the sleeves to retain the feed-wheels in their proper positions on the feed-roll. The upper ends of the sleeves 56 pass through longitudinal slots 52 in the bar 51 and are threaded to receive nuts 63, which retain them in position by drawing the shoulders 64 on the sleeves against the under portions of the bar 51, and the studs 55 pass through the sleeves and are threaded to receive the adjusting-nuts 65, and by means of which the pressure of the feed-wheels on the feed-roll is regulated to suit the thickness of paper being used for the flies.

A roll of paper 70 is carried on a shaft 71, journaled in the side frame of the machine, and is held in position by plates 72, that are adjustable on the shaft 71 to suit any width of paper. Farther to the rear of the machine is a glue-receptacle 73, supported on cross-rods 74, secured in the side frames of the machine, said glue-receptacle having a heating-chamber 75 underneath it, to which steam is admitted through the supply-pipe 76, having a controlling-valve 78, and exhausted through the pipe 77, located at the opposite end of the heat-chamber. Journaled on the glue-receptacle in any suitable manner is a shaft 79, upon which is securely mounted the glue-distributing wheel 80 and over which the strip of

paper passes after it leaves the roll; but the paper being of greater width than the glue-distributing wheel it is necessary to have some support for it, and this is accomplished by having a semicircular shield 81 fastened to the side frame and the top of the receptacle, and being of the same diameter as the glue-wheel and almost touching the face of the same the paper will travel along freely and that portion of it exposed to the glue-wheel will be properly gummed. The paper gummed on the under side then passes down under an idle roller 84, journaled in the side frame and the top of the glue-receptacle, where it comes in contact with a scraper 82, secured to a shaft 83, journaled in the side frame and the top of the glue-receptacle, where the surplus glue is scraped off and runs back into the glue-receptacle. Then passing up around an idle roller 87, carried in the ends of the side frames, the paper passes along gummed side up to the feed-roll and feed-wheels, where it is fed down onto the receiving-table, after which it is cut off and secured to the box by operations hereinafter more fully described.

The main body 95 of the box-receiving table, having a frame 95' secured thereto, is bolted to a gooseneck bracket 96, having split journal-bearings that encircle the bearings 26 of the feed-roll 25 and are loosely secured thereto, so as to form a pivot connection for the oscillatory movement of the table. Pivoted to the lower end of the table is a toggle-link 98, to which is pivoted an under toggle-link 99, said under toggle-link 99 being supported on a rock-shaft 94, journaled in the side frames of the machine at 100 and pivoted to the table toggle-link at 101, thereby forming a toggle-joint connection for raising and lowering the table. Journaled on a rod 102 in the side frame is a downwardly-projecting cam-lever 103, pivoted at its lower end to a rod 104, connected with the lower toggle-link 99, said cam-lever carrying a roller 106, that travels in a groove 107 in the face of a cam 108, fixed to the auxiliary shaft 6, said cam giving a backward-and-forward thrust to the cam-lever, thereby moving the connecting-rod 104 and operating the toggle-joint to raise and lower the table for each revolution of the cam with the auxiliary shaft. The connecting-rod 104 has a right and left handed nut or turnbuckle 105, adapted to shorten or lengthen the rod for adjusting the throw of the toggle and the movement of the table. The main body of the table has two vertical holes 115, that receive studs 116 therein, said studs protruding beyond the top plane of the table and are secured to a dovetail key-bar 117, that lies longitudinally along the top of the table and has slidably arranged thereon dovetail grooved blocks 118, adapted to receive the fly and the box to which the fly is secured, as shown in dotted lines in Fig. 8. The dovetail slots

117' in the slidable blocks are of greater depth than the thickness of the key-bar, so that when the key-bar is released by turning the hand-wheels 119, threaded on the lower ends of the studs 116, the slidable blocks can be moved to any desired position on the key-bar. The stud is then drawn down by the hand-wheels, in turn forcing the key-bar against the table and locking the slidable blocks in the desired positions, as seen in Figs. 7 and 8. The number of slidable blocks on the key-bar is one less than the number required to completely occupy the surface of the key-bar, so that sufficient space is left to adjust the blocks for the different sizes of boxes.

The fly-holding plate 125 extends forward on the table far enough to cover the fly, with the exception of the gummed portion, and has downwardly-projecting pins 126 on the rear edge thereof, that slide in holes 127 in the rear portion of the table-frame 95', the lower end of said pins being provided with heads that abut the lugs 128, secured to the side frame of the machine, and springs 129, surrounding said pins and held in position by the heads on the pins and the bottom of the table. After the fly has been fed onto the table the table rises, the pins 126 are removed from contact with the lugs 128, and the fly-plate is drawn down against the ungummed part of the fly by the springs 129 in such manner that the plate will securely hold the fly until the presser-bar has operated and the table has returned to the position shown in Fig. 1, when the fly-holding plate will be raised again and another fly fed down onto the table.

The paper-cutting mechanism consists of a U-shaped bracket 130, having split journal-bearings 131, Fig. 3, that are loosely secured to the feed-roll shaft 24; the end of the bracket 130 extending along the inner end of the table in an oblique direction (see Fig. 3) and has adjustably secured thereto the knife 132 by means of screws 133. Located underneath the knife-bracket and fastened thereto is an elongated curved plate 134, that serves as a guide and hold-up for the paper after the knife has descended. The loose end of the continuous strip of paper is supported on the plate 134, and when the knife-bracket returns to the position shown in Fig. 1—that is, the initial condition of the machine—the bottom of the plate 134 will be flush with the tops of the slidable blocks 118, so that the paper can again be fed down onto the table and the machine be ready for another operation. The inner end of the table-body 135 serves as an opposing shear-block for the knife, so that when the obliquely-arranged knife descends it will have a shearing action and cut the paper in a clear and decisive manner. A rod 136 is pivoted to one side of the knife-bracket 130 and extends down to and is pivotally connected with a bell-crank lever 137, journaled on the rod 102, the lower arm of

the bell-crank carrying a roller 138, that rides in a groove 139 in the face of a cam 140, fixed to the auxiliary shaft 6, said cam operating to raise and lower the knife-bracket for

5 each revolution of the auxiliary shaft 6.
 After the box has been placed in position on top of the fly lying on the slidable blocks secured to the table the table is raised until it meets the presser-bar 144. The presser-bar is
 10 preferably rectangular in shape, is of sufficient width to cover the gummed portion of the fly, and is pivotally connected to the lower toggle-links 145, pivoted to upper toggle-links 146, said upper toggle-links pivotally
 15 dependent from the supporting-arm 148, secured to the top and side of one of the side frames, and a bar 150, that serves to connect the two toggle-joints together, is secured to the operating-lever 151 by a link 152. This
 20 operating-lever is journaled on a stud 153 to the side frame and has pivoted thereto above the said journal a connecting-rod 154, provided with an elongated right and left threaded nut or turnbuckle 155 for regulating the
 25 throw of the operating-lever. The opposite end of this connecting-rod is pivotally connected with the cam-lever 156, journaled on the stud 102, said cam-lever carrying a roller 157, that travels in a groove 158 in the face of
 30 a cam 159, that is fixed on the auxiliary shaft 6. Attached to the bottom of the presser-bar is a piece of soft material 160, such as rubber or the like, so that the box when brought in contact with the presser-bar will receive
 35 sufficient pressure at all points to make the fly adhere firmly thereto.

The cams controlling the paper-cutting knife, the box-receiving table, and the presser-bar are mounted on the auxiliary shaft 6,
 40 driven by the main shaft, and are so arranged and timed that they will cause the paper-cutting knife to descend simultaneously with the upward movement of the table, and the presser-bar will begin to descend when the
 45 table has about reached the limit of its upward movement, so that when the presser-bar meets the table sufficient pressure will be exerted to secure the fly to the box. (See Fig. 3.) After this operation as the cams
 50 continue to rotate they will cause the table to descend, the paper-cutting knife to ascend, and the presser-bar to recede to their initial positions ready for another operation, as shown in Fig. 1.

55 The operation of the machine is controlled by a treadle 161, located on the operator's side of the machine and having a short shaft 163 rigidly secured thereto, that is journaled in arms 162, bolted to the side frame and extending inwardly under the table. The shaft
 60 163 has fixed thereto an upright standard 164, provided with a semicircularly-grooved head 165 on the top thereof and vertical slots in the side of said head that receive a
 65 horizontal pin 168, carried by the clutch-

shifting rod 167, that is journaled in the side frames, said clutch-shifting rod having secured on the end opposite the treadle an arm 170, that engages the clutch 169, secured on the end of the main driving-shaft. Thus it
 70 will be seen that when the treadle is depressed the short shaft 163 will be rocked, thereby moving the upright standard 164, engaged by the pin 168 in the clutch-shifting rod 167, thereby drawing the clutch-rod toward the operator's side of the machine and causing the arm 170 to force the clutch into engagement with the driving-pulley 3 and start the operation of the machine. Any
 75 standard form of clutch may be employed, as the particular construction of the clutch forms no part of this invention.

The operation of the machine is as follows: Presuming the paper to be in position to be
 80 operated upon by the feed-roll and feed-wheels, power is applied by depressing the treadle and through its connections with the clutch-rod throwing the clutch into engagement with the driving-pulley, thereby rotating the main shaft and the pinion on the end of
 90 said shaft driving the gear 5 and the auxiliary shaft 6. An intermittent forward feed is given to the feed-roll by the gear 5, operating the rack-bar that meshes with the pinion loosely mounted on the bearing of the feed-roll shaft, said pinion intermittently driving
 95 the pawl-carrying disk, the friction-disk, and the ratchet-wheel secured to the feed-roll shaft and operated by the pawl on the pawl-carrying disk. For each upward movement of
 100 the rack-bar the feed-roll and feed-wheels are operated and the paper with the gummed side upward is fed forward and down onto the table, when the feeding will cease because the rack-bar has reached the limit of its up-
 105 ward throw, and as the rack-bar descends it will carry back with it to the initial position the pinion, the pawl-carrying disk, and friction-disk, the ratchet-wheel remaining in its progressed position. The knife-controlling
 110 cam, located on the auxiliary shaft 6, driven by the gear 5, having by this time rotated a sufficient distance to reach the operating portion thereof will draw down the bell-crank lever 137 and rod 136, connected to the knife-
 115 bracket, and start the knife in a downward direction. The box to which the fly is to be secured is then placed over the fly that rests on the slidable blocks on the table, and simultaneously with the above-described action
 120 the table-controlling cam on the auxiliary shaft 6 will be in position to draw the cam-lever arm 103 toward its axis, thereby giving a thrust to the connecting-rod 104, that will operate the toggle-links 98 and 99 and gradually straighten said toggle-joint and cause
 125 the table to ascend. The descent of the knife and the ascent of the table will produce a shearing action between the knife and the end of the table, and the paper will be severed
 130

The presser-bar is operated at the same time by a cam located on the auxiliary shaft 6, that forces the cam-arm 156 away from its axis, which will give a thrust to the connecting-rod 154, thereby pulling the long operating-lever 151, that in turn will operate the toggle-links 145 and 146 to force the presser-bar down against the table when the table has reached the limit of its upward movement, as shown in Fig. 3. After the cams have operated in the manner described and they continue to rotate the reverse action will take place, the knife will ascend, the table descend, and the presser-bar recede to the positions shown in Fig. 1.

Having thus described my invention, the following is what I claim as new and desire to secure by Letters Patent:

1. In a machine for securing flies to boxes, employing a continuous strip of paper, means for gumming the paper, means for feeding the paper onto the box-receiving table, an intermittently-actuated paper-cutting knife, an oscillating box-receiving table, an intermittently-actuated presser-bar, means for actuating the paper-feeding mechanism, means for operating the paper-cutting knife, and means for moving the box-receiving table and the presser-bar toward and from each other.

2. In a machine, for securing flies to boxes, glue-distributing mechanism, intermittently-actuated paper-feeding mechanism, an intermittently-actuated paper-cutting knife, a movable box-receiving table, an intermittently-actuated presser-bar and means for moving the table and presser-bar toward and away from each other.

3. In a machine for securing flies to boxes, the combination of a frame a pivotally-supported box-receiving table, a presser-bar, a rock-shaft journaled in the frame, toggle-links connecting said table to the rock-shaft, a driving-shaft, an auxiliary shaft driven thereby, a cam on said auxiliary shaft, and suitable means connecting said cam to the toggle-links whereby the rotary action of the cam will operate the toggle-links to raise and lower the table for the purposes described.

4. In a machine for securing flies to boxes, the combination of a frame, a presser-bar, a pivotally-supported box-receiving table, toggle-links connected to the table, a rock-shaft journaled in the frame, a driving-shaft, an auxiliary shaft driven thereby, a cam on said auxiliary shaft, a cam-lever pivoted to the machine-frame and operated by said cam and a rod connecting the toggle-links and the cam-lever whereby the rotary action of the cam causes the toggle-links to intermittently raise and lower the table for the purposes described.

5. In a machine for securing flies to boxes, the combination of a frame, a presser-bar, a pivotally-supported box-receiving table, a fly-holding plate carried by the table, means

connected with the plate to hold and release the fly when the table is raised and lowered, the driving-shaft, an auxiliary shaft driven thereby, toggle-links connected to the table, a rock-shaft journaled in the frame of the machine, a grooved-face cam on the auxiliary shaft, a cam-lever journaled to the side frame, and carrying a roller that travels in the groove in the cam and an adjustable rod connecting the toggle-links with the cam-lever whereby the table is raised and lowered during each revolution of the cam, for the purposes described.

6. In a machine for securing flies to boxes, the combination of a movable box-receiving table, a movable presser-bar, means for moving the table and presser-bar toward and from each other, a fly-holding plate carried by the table, the plate adapted to hold the ungummed portion of the fly when the table is raised, and release it when the table is lowered, a key-bar supported on the table, a series of sliding blocks mounted on the key-bar and means for lowering and raising said key-bar to clamp and release the sliding blocks.

7. In a machine for securing flies to boxes, the combination of a pivotally-supported box-receiving table, a presser-bar, means for moving the table and presser-bar toward and from each other, a fly-holding plate, pins carried by the plate and received in holes in the table, resilient means carried by the pins for drawing the plate down upon the fly when the table is traveling toward one limit of its movement and means for lifting the fly-holding plate when the table is traveling toward its opposite limit of movement.

8. In a machine for securing flies to boxes, the combination of a feed-roll shaft a knife-bracket pivotally supported on the feed-roll shaft and having a knife adjustably attached thereto, an opposing shear-block, the driving-shaft, an auxiliary shaft driven thereby, a grooved-face cam secured to the auxiliary shaft, a side frame, a bell-crank lever journaled to the side frame and carrying a roller that travels in the groove in the cam, and a connecting-rod having its respective ends pivoted to the knife-bracket and the bell-crank lever, said parts operating to intermittently lower and raise the knife-bracket during each revolution of the cam for the purposes described.

9. In a machine for securing flies to boxes, the combination of a feed-roll shaft a knife-bracket pivotally supported on the feed-roll shaft and having a knife adjustably attached thereto, an opposing shear-block a plate fastened to the bracket for supporting the end of the paper after the knife has descended, the driving-shaft the auxiliary shaft, the cam, the bell-crank lever and the connecting-rod operating to lower and raise the knife for the purposes described.

10. In a machine for securing flies to boxes, the combination of a frame, an operating-lever pivoted to the frame, toggle-links connected to the operating-lever, a presser-bar 5 pivotally connected with the frame by means of the toggle-links, a table adapted to cooperate with the presser-bar, the driving-shaft, the auxiliary shaft driven thereby, a grooved-face cam on said auxiliary shaft, a cam-lever 10 journaled to the side frame and carrying a roller that travels in a groove in the cam and an adjustable connecting-rod having its respective ends connected to the cam-lever and the operating-lever, whereby the presser-bar 15 will be intermittently lowered and raised during each revolution of the cam for the purposes described.

11. In a machine for securing flies to boxes, the combination of a driving-shaft, an auxiliary shaft driven thereby, a gear on said auxiliary shaft, a rack-bar operated by the gear and adapted to engage a pinion on the feed-roll shaft, the feed-roll and supporting-shaft 20 carrying the rack-engaging pinion feed-wheels and a pawl and ratchet operatively connected to the pinion and feed-roll shaft for intermittently feeding the paper for the purposes described.

12. In a machine for securing flies to boxes, the combination of a driving-shaft, an auxiliary shaft driven thereby, said auxiliary shaft having a gear thereon a pinion secured to the driving-shaft meshing with and driving the gear on the auxiliary shaft, a rack-bar 35 adjustably attached to said gear, a rack-bar guide pivotally supported on the bearings of the feed-roll shaft, the feed-roll shaft having a pinion loosely mounted thereon and engaging the rack-bar, a feed-roll on said 40 shaft, feed-wheels a pawl-carrying disk mounted on and secured to the rack-bar pinion, a friction-disk carried on the feed-roll shaft, a ratchet-wheel secured to the feed-roll shaft, the pawl on the pawl-carrying disk 45 engaging the ratchet-wheel a pin on the periphery of the friction-disk engaging the pawl to throw it in and out of engagement with the ratchet-wheel and a spring forcing the friction-disk in contact with the ratchet-wheel for the purposes described. 50

13. In a machine for securing flies to boxes, the combination of a driving-shaft an auxiliary shaft driven thereby, a rotatably-supported feed-roll shaft, a feed-roll thereon, a 55 gear on the auxiliary shaft, a rack-bar operated by the gear, a pinion and a pawl-carrying disk on the feed-roll shaft, the pinion and pawl-carrying disk being operatively connected, a pawl on the disk, a ratchet-wheel 60 secured to the feed-roll shaft and engaged by the pawl, and a plurality of adjustable feed-wheels held in contact with the feed-roll.

14. In a machine for securing flies to boxes the combination of the machine-frames, the 65 feed-roll, a slotted bar secured thereto over

the feed-roll, a plurality of feed-wheels supported on studs sleeves in which the studs are adjustably held and guided said sleeves secured to the slotted bar and held in frictional contact with the feed-roll by springs 70 in the sleeves for the purposes described.

15. The combination in a fly-pasting machine, with a suitably-driven shaft, and a wheel carried thereby, of a slotted block secured to the wheel, a headed stud, the head 75 of which is received in the slot, means in the slot and engaging the head of the stud for adjusting the latter longitudinally of the slot, a rack-bar one end of which is journaled on the projecting portion of the stud, a suitably- 80 supported feed-roll and means engaged by the rack-bar for communicating motion to the feed-roll.

16. The combination in a fly-pasting machine, with a feed-roll, of a swinging box- 85 supporting table located in advance of the feed-roll whereby a space is left between the feed-roll and the table, a swinging paper-cutting means operating in the space, and a paper-supporting means carried by the paper- 90 cutting means for bridging the space between the feed-roll.

17. The combination in a fly-pasting machine with a feed-roll, of a swinging table spaced apart from the feed-roll, a knife carried by that edge of the table nearest the 95 feed-roll, a swinging paper-cutting knife operating in the space between the feed-roll and table and in conjunction with the knife carried by the table and a paper-supporting 100 means carried by the swinging knife and bridging the space between the feed-roll and the table.

18. The combination in a fly-pasting machine, of a pivotally-supported swing-box- 105 supporting table, a paper-feeding mechanism for feeding a fly onto the table, a paper-cutting mechanism and means for swinging the paper-cutting mechanism and the table 110 simultaneously in opposite directions to effect a cutting of the paper and to bring the box-carrying table into operative position.

19. The combination in a fly-pasting machine, of a box-supporting table, a key-bar supported on the table, a series of blocks slid- 115 ably mounted on the bar and means for locking and releasing the blocks relative to the key-bar and table.

20. The combination in a fly-pasting machine, of a movable box-supporting table, a 120 fly-holding plate carried by the table and normally tending to lie thereupon and projecting means carried by the plate adapted to engage a stationary portion of the machine during the movement of the table to 125 raise the plate away from the table.

JAMES PHILIP BIRD.

Witnesses:

WM. A. COURTLAND,
J. GREEN.