

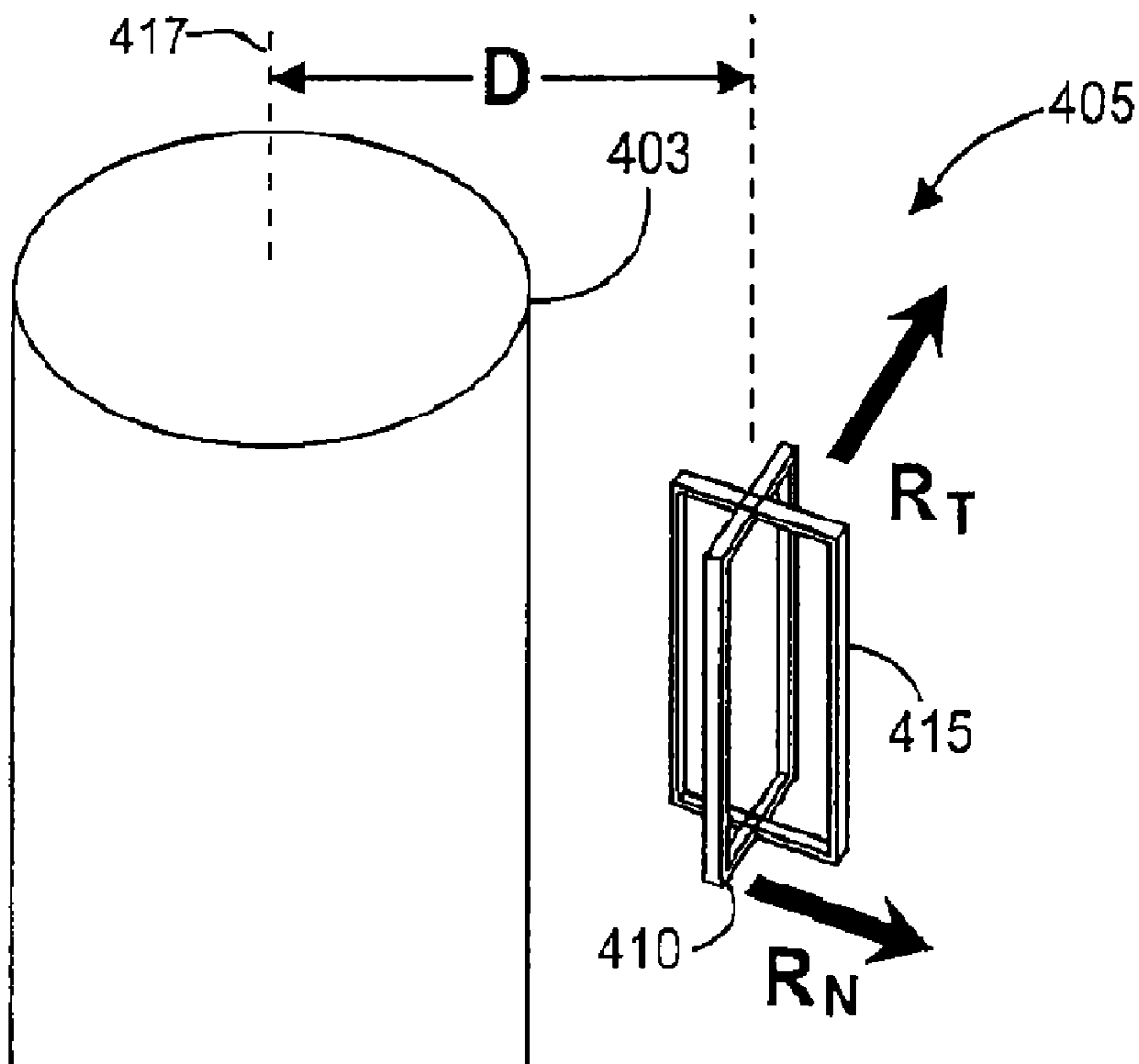

(86) Date de dépôt PCT/PCT Filing Date: 2011/11/18
 (87) Date publication PCT/PCT Publication Date: 2013/05/23
 (45) Date de délivrance/Issue Date: 2015/07/28
 (85) Entrée phase nationale/National Entry: 2014/05/15
 (86) N° demande PCT/PCT Application No.: US 2011/061414
 (87) N° publication PCT/PCT Publication No.: 2013/074121

(51) Cl.Int./Int.Cl. *G01V 3/20* (2006.01),
E21B 47/022 (2012.01)
 (72) Inventeurs/Inventors:
LI, SHANJUN, US;
BITTAR, MICHAEL S., US;
WU, DAGANG, US
 (73) Propriétaire/Owner:
HALLIBURTON ENERGY SERVICES, INC., US
 (74) Agent: NORTON ROSE FULBRIGHT CANADA
LLP/S.E.N.C.R.L., S.R.L.

(54) Titre : SYSTEMES ET METHODOLOGIE DE DETECTION D'UNE STRUCTURE CONDUCTRICE
 (54) Title: SYSTEMS AND METHODOLOGY FOR DETECTING A CONDUCTIVE STRUCTURE



(57) Abrégé/Abstract:

Various embodiments include apparatus and methods to detect and locate conductive structures below the earth's surface. Tools can be configured with receiving sensors arranged to receive signals generated from a conductive structure in response to a current flowing on the conductive structure. Magnetic-related values from the signals can be processed, relative to the tool, to determine a position of a conductive structure from which the signal was generated in response to current flowing on the conductive structure. Additional apparatus, systems, and methods are disclosed.

(12) INTERNATIONAL APPLICATION PUBLISHED UNDER THE PATENT COOPERATION TREATY (PCT)

(19) World Intellectual Property
Organization
International Bureau(43) International Publication Date
23 May 2013 (23.05.2013)(10) International Publication Number
WO 2013/074121 A1

(51) International Patent Classification:

G01V 3/20 (2006.01) *E21B 47/022* (2012.01)

(21) International Application Number:

PCT/US2011/061414

(22) International Filing Date:

18 November 2011 (18.11.2011)

(25) Filing Language:

English

(26) Publication Language:

English

(71) Applicant (for all designated States except US): **HAL-LIBURTON ENERGY SERVICES, INC.** [US/US]; 10200 Bellaire Blvd, Houston, Texas 77072 (US).

(72) Inventors; and

(75) Inventors/Applicants (for US only): **LI, Shanjun** [CN/US]; 2811 Grants River Circle, Sugar Land, Texas 77479 (US). **BITTAR, Michael S.** [US/US]; 8711 Wheatland Drive, Houston, Texas 77064 (US). **WU, Dagang** [CN/US]; 5014 Big Meadow, Katy, Texas 77494 (US).(74) Agents: **MADDEN, Robert B.** et al.; Schwegman, Lundberg & Woessner, PA, P.O. Box 2938, Minneapolis, Minnesota 55402 (US).

(81) Designated States (unless otherwise indicated, for every kind of national protection available): AE, AG, AL, AM,

AO, AT, AU, AZ, BA, BB, BG, BH, BR, BW, BY, BZ, CA, CH, CL, CN, CO, CR, CU, CZ, DE, DK, DM, DO, DZ, EC, EE, EG, ES, FI, GB, GD, GE, GH, GM, GT, HN, HR, HU, ID, IL, IN, IS, JP, KE, KG, KM, KN, KP, KR, KZ, LA, LC, LK, LR, LS, LT, LU, LY, MA, MD, ME, MG, MK, MN, MW, MX, MY, MZ, NA, NG, NI, NO, NZ, OM, PE, PG, PH, PL, PT, QA, RO, RS, RU, RW, SC, SD, SE, SG, SK, SL, SM, ST, SV, SY, TH, TJ, TM, TN, TR, TT, TZ, UA, UG, US, UZ, VC, VN, ZA, ZM, ZW.

(84) Designated States (unless otherwise indicated, for every kind of regional protection available): ARIPO (BW, GH, GM, KE, LR, LS, MW, MZ, NA, RW, SD, SL, SZ, TZ, UG, ZM, ZW), Eurasian (AM, AZ, BY, KG, KZ, MD, RU, TJ, TM), European (AL, AT, BE, BG, CH, CY, CZ, DE, DK, EE, ES, FI, FR, GB, GR, HR, HU, IE, IS, IT, LT, LU, LV, MC, MK, MT, NL, NO, PL, PT, RO, RS, SE, SI, SK, SM, TR), OAPI (BF, BJ, CF, CG, CI, CM, GA, GN, GQ, GW, ML, MR, NE, SN, TD, TG).

Declarations under Rule 4.17:

— of inventorship (Rule 4.17(iv))

Published:

— with international search report (Art. 21(3))

(54) Title: SYSTEMS AND METHODOLOGY FOR DETECTING A CONDUCTIVE STRUCTURE

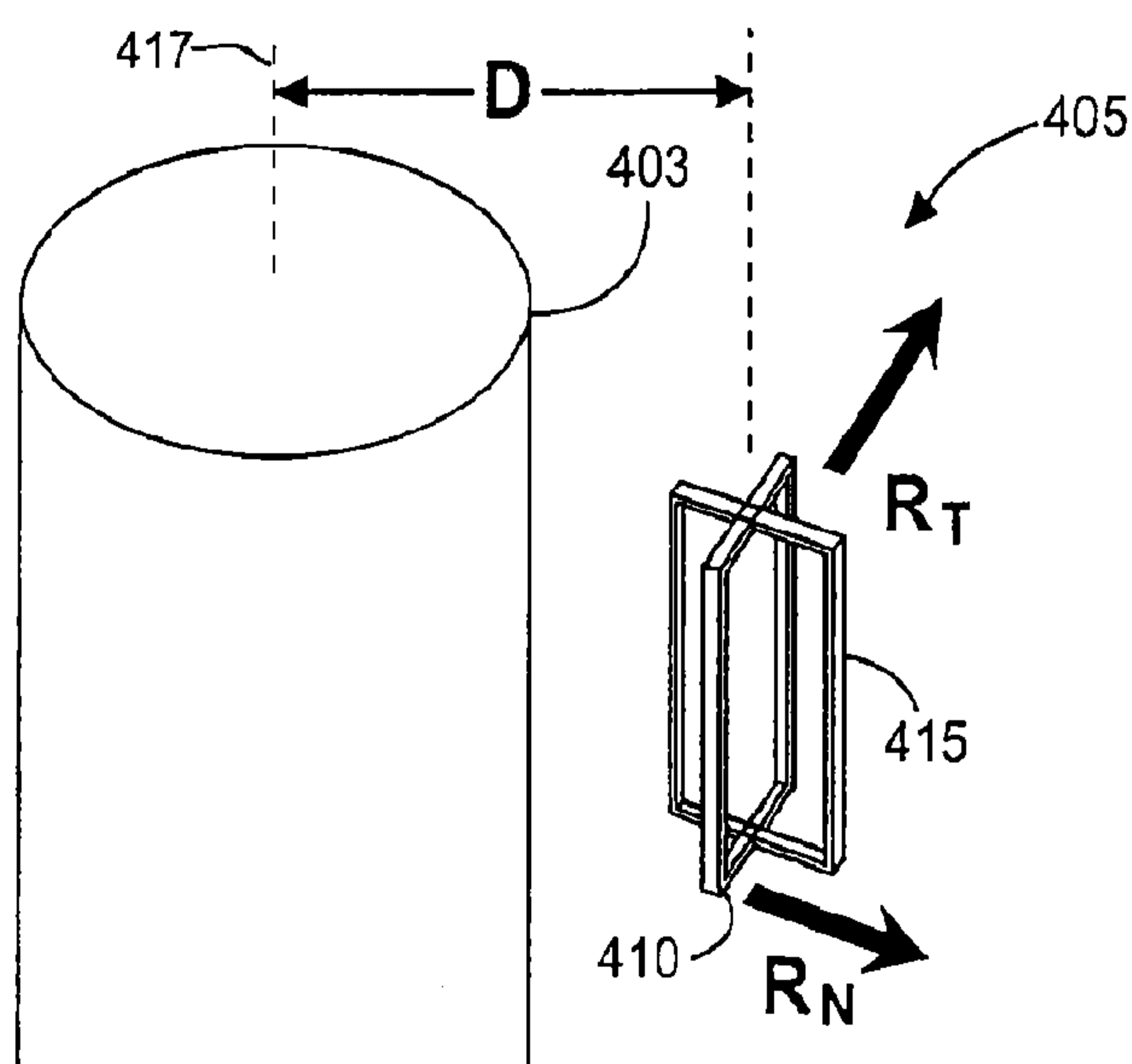

Fig. 4

(57) Abstract: Various embodiments include apparatus and methods to detect and locate conductive structures below the earth's surface. Tools can be configured with receiving sensors arranged to receive signals generated from a conductive structure in response to a current flowing on the conductive structure. Magnetic-related values from the signals can be processed, relative to the tool, to determine a position of a conductive structure from which the signal was generated in response to current flowing on the conductive structure. Additional apparatus, systems, and methods are disclosed.

SYSTEMS AND METHODOLOGY FOR DETECTING A CONDUCTIVE STRUCTURE

Technical Field

5 The invention relates generally to apparatus for making measurements related to oil and gas exploration.

Background

10 In drilling wells for oil and gas exploration, understanding the structure and properties of the associated geological formation provides information to aid such exploration. In addition, drilling can be enhanced with systems and methods to detect conductive structures below the earth's surface. The conductive structures can include metal piping used in various drilling techniques, where the positioning of the metal piping can be important to the
15 drilling operation.

Brief Description of the Drawings

 Figure 1 illustrates an example system operable to determine a position of a conductive structure, in accordance with various embodiments.

20 Figure 2 shows features of an example method of determining a position of a conductive structure relative to a tool structure on which receiver sensors are mounted, in accordance with various embodiments.

 Figure 3 shows an example of a current on a casing that induces a magnetic field that is detected by a receiver on a drilling pipe, in accordance
25 with various embodiments.

 Figure 4 shows an example tool to detect a conductive structure in a formation, in accordance with various embodiments.

 Figure 5 shows a relationship between a conductive structure and receivers of a tool disposed on a structure parallel to the conductive structure, in
30 accordance with various embodiments.

 Figure 6 shows tangential and normal magnetic fields on the surface of the structure on which the tool of Figure 5 is disposed, in accordance with various embodiments.

PPH

Figures 7A and 7B show simulated tangential measurements of a receiver of Figure 4, in accordance with various embodiments.

Figure 8 shows measurements of a normal component of a magnetic field with respect to bin number, in accordance with various embodiments.

Figure 9 shows a relationship between distance and the ratio of maximum magnetic field and minimum magnetic field, in accordance with various embodiments.

Figure 10 shows a relationship between the real distance and computed distance, in accordance with various embodiments.

Figure 11 shows two bins at which a curve of a tangential magnetic field and a curve of a normal magnetic field intersect, in accordance with various embodiments.

Figure 12 depicts a block diagram of features of an example system having a tool configured with receiver sensors, in accordance with various embodiments.

Figure 13 depicts an example system at a drilling site, where the system includes a tool configured with receiver sensors, in accordance with various embodiments.

Summary

In accordance with a general aspect, there is provided a method comprising: acquiring signals corresponding to received signals in two receiver sensors of a tool disposed below the earth's surface, the two receiver sensors arranged orthogonal to each other; generating magnetic-related values from the acquired signals; and processing the magnetic-related values to determine, relative to a tool structure to which the two receiver sensors are coupled, a position of a conductive structure from which the received signals were generated in response to current flowing on the conductive structure, including determining a distance (Dis) using a ratio related to minimum magnetic field measured and maximum magnetic field measured.

In accordance with another general aspect, there is provided a system comprising: two receiver sensors of a tool structured to couple to a structure operable to be disposed below the earth's surface to receive signals in the two receiver sensors disposed below the earth's surface, the two receiver sensors arranged orthogonal to

PPH

each other relative to the structure to which the two receiver sensors are coupled; and a control unit operable to manage collection of received signals at the receiver sensors with respect to current flowing on a conductive structure below the earth's surface; and a data processing unit to process the received signals to determine a position of the conductive structure including to determine distance using a ratio related to minimum magnetic field measured and maximum magnetic field measured.

Detailed Description

The following detailed description refers to the accompanying drawings that show, by way of illustration and not limitation, various embodiments in which the invention may be practiced. These embodiments are described in sufficient detail to enable those skilled in the art to practice these and other embodiments. Other embodiments may be utilized, and structural, logical, and electrical changes may be made to these embodiments. The various embodiments are not necessarily mutually exclusive, as some embodiments can be combined with one or more other embodiments to form new embodiments. The following detailed description is, therefore, not to be taken in a limiting sense.

Figure 1 shows a block diagram of an embodiment of a system 100 having a tool 105 to determine a position of a conductive structure. System 100 includes a tool structure 103 having an arrangement of sensors 111-1, 111-2 . . .

111-(N-1), 111-N along a longitudinal axis 117 of tool structure 103. Each sensor 111-1, 111-2 . . . 111-(N-1), 111 -N can be utilized as a transmitting sensor or a receiving sensor under the control of control unit 115 operating in region 102. Tool 105 and the methods of using tool 105 can be applied in deep-
5 water exploration to obtain structure dip angle, azimuth, and resistivities, R_h and R_v .

Two sensors 111-J and 111-K of the sensors 111-1, 111-2 . . . 111-(N-1), 111-N can be structured to determine the position of a conductive structure relative to tool structure 103. The two sensors 111-J and 111-K can be arranged
10 as receiver sensors with the two sensors 111-J and 111-K oriented orthogonal to each other. Tool 105 may be realized as a tool dedicated to determine a position of a conductive structure, where the tool consists of one or more pairs of receiver sensors with receiver sensor of each pair oriented orthogonal to each other.

Tool 105 can include a control unit 115 operable to manage collection of
15 received signals at the receiver sensors 111-J and 111-K with respect to current flowing on a conductive structure below the earth's surface to determine the relative position of the conductive structure. Such a determination can be realized in a data processing unit 120 of tool 105, where data processing unit 120 can be structured to process the received signals to determine a position of the
20 conductive structure. System 100 can include a current transmitter to flow current on the conductive structure. The current transmitter can be managed by control unit 115.

Data processing unit 120 and control unit 115 can be structured to be operable to generate magnetic-related values from the received signals at
25 receiver sensors 111-J and 111-K; and to process the magnetic-related values to determine, relative to the tool structure 103, the position of the conductive structure from the magnetic-related values and a bin angle associated with the receiver sensors 111-J and 111-K attached to the tool structure 103. Tool structure 103 may be part of a drilling pipe and the conductive structure, whose
30 position is under determination, may be a casing in formation layers below a surface of a drilling region of a well. The conductive structure may be a casing in formation layers below the bottom of a water region, for example, associated with offshore drilling. The conductive structure may include other piping and

conductive structures associated with drilling operations.

Figure 2 shows features of an example method of determining a position of a conductive structure relative to a tool structure on which receiver sensors are mounted. At 210, signals corresponding to received signals in two receiver
5 sensors of a tool disposed below the earth's surface are acquired. The two receiver sensors can be arranged oriented orthogonal to each other. The signals received at the two receiver sensors can be measured voltages that correspond to a magnetic field at the receiver sensors. Attaining the received signals can include using two receiver coils on the tool oriented orthogonal to each other to
10 collect the signals generated from the conductive structure. The tool structure may be oriented parallel with the conductive structure. The conductive structure can include a casing associated with a well and the tool structure can be structured as part of a drilling pipe.

At 220, magnetic-related values from the acquired signals are generated.
15 The magnetic-related values may be ratios of the maximum measured magnetic field and the minimum measured magnetic field. The magnetic-related values may be ratios of x and y components of a measured magnetic field. The magnetic-related values may be ratios of tangential and normal components of a measured magnetic field.

20 At 230, the magnetic-related values are processed to determine, relative to a structure to which the two receiver sensors are coupled, a position of a conductive structure from which the received signals were generated in response to current flowing on the conductive structure. The current flowing on the conductive structure can include directly generating the current on the
25 conductive structure. Processing the magnetic-related values can include calculating distance to the conductive structure based on the generated magnetic-related values. Processing the magnetic-related values can include calculating an azimuthal angle of the tool relative to the conductive structure based on the generated magnetic-related values.

30 Determining a position of a conductive structure relative to a structure on which a tool, having two receiver sensors, is mounted can include collecting received signals at the two receiver sensors with the tool rotating; associating the received signals with a bin of the tool, the bin corresponding to an angle of the

tool when the signals are collected; collecting additional received signals and assigning the additional received signals to different bins, each bin corresponding to an azimuthal direction of the rotating tool; and determining angular position of the conductive structure, relative to the relative to the structure to which the two receiver sensors are coupled, from determining which bin includes a largest absolute value of a difference between a maximum magnetic-related value derived from the received signal in the respective bin and an average magnetic-related value.

Determining the position of the conductive structure can include determining, with no current on the tool structure and with value of the current on the conductive structure unknown, distance (Dis) with respect to a ratio related to minimum magnetic field measured, H_{Minimum} , and maximum magnetic field measured, H_{Maximum} . Determining the position of the conductive structure can include determining, with current on the tool structure, distance (Dis) with respect to a ratio related to minimum magnetic field measured, H_{Minimum} , and maximum magnetic field measured, H_{Maximum} .

Determining a position of a conductive structure relative to a structure on which a tool, having two receiver sensors, is mounted can include collecting received signals at the two receiver sensors with the tool in a non-rotating mode; generating magnetic-related values based on the received signals as orthogonal magnetic-related component values; and calculating the angular position of the conductive structure relative to the tool using the orthogonal magnetic-related component values and a bin angle of the tool in the non-rotating mode.

Determining a position of a conductive structure relative to a structure on which a tool, having two receiver sensors, is mounted can include associating the received signals at the receiver sensors with a bin angle of the tool, the bin angle corresponding to an angle of the tool when the received signals are collected; and performing an inversion process using a measured parameter of the received signal and the bin angle to generate an azimuthal angle of the tool with respect to the conductive structure. Performing the inversion process can include using curve-fitting functions.

In various embodiments, a tool is operated to determine the relative position of a conductive structure in a formation with respect to a structure on

which the tool is mounted. The tool can operate according to various
embodiments of a methodology that operates on signals received by the tool
from the conductive structure. The position can be determined by computing the
relative azimuthal angle of the conductive structure with respect to the tool based
5 on the receive signals and by computing the distance between the structure on
which the tool is mounted and the conductive structure based on the received
signals. Different methodologies can be applied based on the settings of
receivers on the tool, for example operating as a rotating tool or as a non-rotating
tool. The tool and methodologies can be applied to a casing of a drilling
10 operation with respect to a drilling/logging tool.

A tool can be operated based on signals received from the conductive
structure that the tool is being used to detect. The source of the signals, which
can be used to detect the conductive structure such as a casing, can be a current
flowing on the conductive structure. This current can be induced by another
15 source or can be applied to the conductive structure directly. The current on the
conductive structure can induce magnetic fields around the conductive structure,
which can be measured by receivers mounted on the tool. The measured signal
from the receivers can be used to determine the position of the conductive
structure. The receivers can be mounted on a drilling pipe to determine the
20 position of a casing relative to the drilling pipe. Figure 3 shows an example of a
current on a casing 301 that induces a magnetic field that is detected by a
receiver 311 on a drilling pipe 303.

Figure 4 shows an example embodiment of a tool 405 to detect a
conductive structure in a formation. Tool 405 can include receivers 410, 415
25 selected as orthogonal coils. Receivers 410, 415 of tool 405 can be arranged as
intersecting coils, where D is the distance between the center of the receiving
coils 410, 415 and the center 417 of the drilling pipe 403 on which tool 405 is
disposed. One coil 410, referred to herein as R_N , can be positioned parallel with
the surface of a drilling pipe 403 and the other coil 415, referred to herein as R_T ,
30 can be positioned perpendicular to the surface of drilling pipe 403. The
measurements on R_N and R_T can be realized as voltages induced by normal and
tangential magnetic fields, respectively. The measurements can be transferred to
X and Y directional measurements with a tool rotation operation.

Figure 5 shows a relationship between a conductive structure 501 and receivers of a tool 505 disposed on a structure parallel to the conductive structure 501. The relationship is shown as a relative azimuthal angle of conductive structure 501 with respect to tool 505. X-direction and Y-direction components of a magnetic field are generated at tool 505 by the current on conductive structure 501. The structure can be realized as a drilling pipe parallel to a casing, where the casing is conductive structure 501, whose position is to be determined.

Figure 6 shows tangential and normal magnetic fields on the surface of the structure on which tool 505 of Figure 5 is disposed. The tangential and the normal magnetic fields can be computed by the following formula from X-direction and Y-direction components:

$$H_t = -H_x \sin(\phi_{Bin}) + H_y \cos(\phi_{Bin}), \quad (1a)$$

$$H_n = +H_x \cos(\phi_{Bin}) + H_y \sin(\phi_{Bin}), \quad (1b)$$

where H_t , H_n , H_x , and H_y represent tangential, normal, X-direction, and Y-direction magnetic fields. The angle ϕ_{Bin} is the bin angle. For a tool that can be rotated, such as being arranged on a drilling pipe that rotates, the rotation can be divided into a number of equal partitions of 360 degrees of rotation, where the partitions are referred to as bins. For example, measurements over 360 degrees can be divided into 32 bins, where each bin covers 11.25 degrees. The number of bins can be less than or more than 32 bins. The tool can be operated without rotation, while making measurements relative to a bin. Corresponding tangential and normal voltage measurements, V_t and V_n can be expressed as

$$V_t = -V_x \sin(\phi_{Bin}) + V_y \cos(\phi_{Bin}), \quad (1c)$$

$$V_n = +V_x \cos(\phi_{Bin}) + V_y \sin(\phi_{Bin}), \quad (1d)$$

where V_x and V_y represent the voltage measurements of X and Y directional coils, respectively. Since measured voltages and magnetic fields can be transferred between each other, the following discussion can be based on measured magnetic fields, but are applicable for the measured voltages.

Figures 7A and 7B show simulated tangential measurements of receiver R_T of Figure 4. Figure 7A displays the simulated results of tangential measurements with respect to bin number for a drilling pipe without current

flowing. Figure 7B displays the simulated results of tangential measurements with respect to bin number for the drilling pipe with current flowing. The simulated magnetic field in Figure 7B should be a shift from Figure 7A, since the measurement of R_T includes the magnetic field induced by the current on the drilling pipe, directly, which is independent to the rotation angle. The curves, shown in Figures 7A and 7B, look like a sinusoidal curves, but actually are not, since $|H_{Maximum} - H_{Average}|$ is not equal to $|H_{Minimum} - H_{Average}|$. The difference between these two differences can be used to compute the distance from a structure, on which a tool is located, to a conductive structure, such as the distance from a drilling pipe to a casing.

Figure 8 shows measurements of a normal component of a magnetic field with respect to bin number. The measurements of R_N display 90° bin shift from R_T measurements. Since the R_T measurements are not sensitive to the magnetic field induced by the current on drilling pipe, the R_T measurements only reflect the conductive structure such as a casing.

If measurements of the tangential component are taken, the corresponding bin number with maximum values of $|H_{Maximum} - H_{Average}|$ and $|H_{Minimum} - H_{Average}|$ points to the direction of the conductive structure. Hence, the direction of the conductive structure can be extracted from real-time bin curves. In addition, the conductive structure is located at the plane, which is perpendicular to the direction from the bin with minimum value to the bin with maximum value of R_N measurements.

If the structure on which the tool is disposed does not rotate, for example when the tool slides down a borehole, the shape of curve with respect to bin number, shown in Figure 8, cannot be obtained. Nevertheless, equation (2a) and equation (2b) can be used to compute the azimuthal angle of the conductive structure with respect to the X direction, shown in Figures 5 and 6, if the current on the structure is DC.

$$\phi = \frac{\pi}{2} + \tan^{-1}\left(\frac{H_y}{H_x}\right), \text{ for } H_x > 0. \quad (2a)$$

$$\phi = \frac{3\pi}{2} + \tan^{-1}\left(\frac{H_y}{H_x}\right), \text{ for } H_x > 0. \quad (2b)$$

where

$$H_x = -H_t \sin(\phi_{Bin}) + H_n \cos(\phi_{Bin}), \quad (2c)$$

$$H_y = H_t \cos(\phi_{Bin}) + H_n \sin(\phi_{Bin}), \quad (2d)$$

- 5 If there is no current on the structure containing the tool and the current on the conductive structure is unknown, the following formula can be used to compute the distance from the drilling tool to the casing:

$$Dis = k_1 \frac{(1 + \alpha_1) \cdot D}{1 - \alpha_1} \quad (3a)$$

$$Dis = k_1 \frac{(\alpha_2 + 1) \cdot D}{\alpha_2 - 1} \quad (3b)$$

- 10 where $\alpha_1 = \text{abs}\left(\frac{H_{Minimum}}{H_{Maximum}}\right)$, $\alpha_2 = \text{abs}\left(\frac{H_{Maximum}}{H_{Minimum}}\right)$ and k_1 is a constant which can

be determined by calibration. Figure 9 shows a relationship between the distance and the ratio α for $D = 4$ inch, where the distance D is shown in Figure 4 and α is the one of $(1 - \alpha_1)$ or $(\alpha_2 - 1)$ that is greater than zero. Figure 10 shows a relationship between the real distance and computed distance.

- 15 If the current on a conductive structure, such as a casing, is known, the average of absolute maximum measurement value and the absolute minimum measurement value can be used to compute the distance with the following formula:

$$Dis = k_2 \frac{I}{H_{average}}, \quad (4)$$

20

where $H_{average} = \frac{|H_{Maximum}| + |H_{Minimum}|}{2}$, I is the current on the conductive structure,

k_2 is a constant, which can be determined by calibration. If equation (3) is used to compute the distance and this distance is substituted into equation (4), an equivalent current on the conductive structure can be computed:

25

$$I = \frac{k_1 (1 + \alpha_1) \cdot D}{k_2 (1 - \alpha_1)} H_{average} \quad (5a)$$

$$I = \frac{k_1 (1 + \alpha_2) \cdot D}{k_2 (\alpha_2 - 1)} H_{average} \quad (5b)$$

Once the equivalent current is known, it can be used to compute the distance to the conductive structure with the following formula when the tool slides down and does not rotate, since the current on a conductive structure such as a casing drops very slowly:

$$5 \quad Dis = k_3 \frac{I}{H_0}, \quad (6)$$

where $H_0 = \sqrt{H_x^2 + H_y^2}$ or $H_0 = \sqrt{H_T^2 + H_N^2}$ and k_3 is a constant, which can be determined by calibration.

If the structure on which the tool is disposed has current flowing, the following formula can be used to compute the distance from the structure to the
10 conductive structure:

$$Dis = k_4 \frac{(1 + \alpha_1) \cdot D}{1 - \alpha_1} \quad (7a)$$

$$Dis = k_4 \frac{(1 + \alpha_2) \cdot D}{\alpha_2 - 1} \quad (7b)$$

where $\alpha_1 = abs\left(\frac{H_{Minimum} - H_{Average}}{H_{Maximum} - H_{Average}}\right)$, $\alpha_2 = abs\left(\frac{H_{Maximum} - H_{Average}}{H_{Minimum} - H_{Average}}\right)$ and k_4 is a constant which can be determined by calibration.

15 In various embodiments, received signals at receiver sensors of the tool can be associated with a bin angle of the tool, where the bin angle corresponds to an angle of the tool when the signal is collected. An inversion process using a measured parameter of the received signals and the bin angle can be performed to generate an azimuthal angle of the tool with respect to the conductive
20 structure. Inversion is a process of searching for optimum match between simulated data and measurements. Performing the inversion process can include using curve-fitting functions. Examples of curve fitting functions include

$$H_{\phi_{Bin}}^T = A_T \frac{\cos(\phi_{Bin} + \phi_0)}{\sqrt{dis^2 + D^2 - 2 \cdot dis \cdot D \cdot \cos(\phi_{Bin} + \phi_0)}} + B_T, \text{ for tangential direction}$$

$$\text{measurements, and } H_{\phi_{Bin}}^N = A_N \frac{\cos(\phi_{Bin} + \phi_0 + \frac{\pi}{2})}{\sqrt{dis^2 + D^2 - 2 \cdot dis \cdot D \cdot \cos(\phi_{Bin} + \phi_0)}} + B_N, \text{ for}$$

25 normal direction measurements, where B_T is an average tangential magnetic field, B_N is an average normal magnetic field, A_T and A_N are curve-fitting

coefficients, dis is the distance from the tool to the conductive structure, ϕ_{Bin} is bin angle, D is distance between center of the receiver sensors and center of a tool structure on which the receiver sensors are mounted, and ϕ_0 is azimuthal angle of the tool structure with respect to the conductive structure. Four parameters, with respect to the conductive structure in Figure 5, that can be inverted include A , B , dis , and azimuthal angle ϕ_0 . For tangential direction measurements, α_1 and α_2 factors become

$$\alpha_1 = abs\left(\frac{H_{Minimum}^T - B_T}{H_{Maximum}^T - B_T}\right), \alpha_2 = abs\left(\frac{H_{Maximum}^T - B_T}{H_{Minimum}^T - B_T}\right).$$

Figure 11 shows two bins at which a curve of a tangential magnetic field and a curve of a normal magnetic field intersect. The two curves are provided by plotting Figure 7A and Figure 8 in one figure. As shown in Figure 11, these curves in one figure display two bins at which the two curves intersect. One bin with negative value has 135° bin shift respect to the conductive structure; the other bin with positive value has a -45° bin shift, which is a fast method to determine the direction of the conductive structure. If the measurements of Figure 7B are subtracted from the average of the data and the curve is plotted in the same figure with the curve of Figure 8, one can attain almost the same results of Figure 11.

In various embodiments, orthogonal coils can be used as receivers, which can measure tangential and normal direction magnetic fields on the surface of a drilling tool. Methodologies as taught herein can be used to detect the position of a conductive structure when there is a current flow on the conductive structure. Methodologies as taught herein can be used to determine relative azimuthal angle of a casing with respect to a drilling tool and can be used to compute the distance between the casing and the drilling tool. The tool can be used in rotation and can be used without rotation such as with the tool sliding down a borehole.

Various components of a system including a tool, having receiver sensors arranged to receive signals in response to current flowing on a conductive structure and having a data processing unit to process the magnetic-related values based on the received signals to determine, relative to the tool structure,

the position of the conductive structure, as described herein or in a similar manner, may be realized in combinations of hardware and software based implementations. These implementations may include a machine-readable storage device having machine-executable instructions, such as a computer-readable storage device having computer-executable instructions, to acquire signals corresponding to received signals in two receiver sensors of a tool disposed below the earth's surface, the two receiver sensors arranged orthogonal to each other; generate magnetic-related values from the acquired signals; and process the magnetic-related values to determine, relative to a structure to which the two receiver sensors are coupled, a position of a conductive structure from which the received signals were generated in response to current flowing on the conductive structure. The instructions can include instructions to manage the tool and detect conductive structure using magnetic-related values in accordance with the teachings herein. Further, a machine-readable storage device, herein, is a physical device that stores data represented by physical structure within the device. Examples of machine-readable storage devices include, but are not limited to, read only memory (ROM), random access memory (RAM), a magnetic disk storage device, an optical storage device, a flash memory, and other electronic, magnetic, and/or optical memory devices.

Figure 12 depicts a block diagram of features of an example embodiment of a system 1200 having a tool 1205 configured with sensors arranged to determine a conductive structure below the earth's surface based on magnetic-related measurements in response to current flowing on the conductive structure. The sensors can be arranged as one or more pairs of receiver sensors, where the two receiver sensors of each pair can be arranged orthogonal to each other. The structure on which the receiver sensors may be attached may be a drilling pipe. The conductive structure whose position is to be determined may include a casing of a well. System 1200 includes tool 1205 having an arrangement of receiver sensors 1210 that can be realized in a similar or identical manner to arrangements of sensors discussed herein. Tool 1205 may include transmitters/receivers 1212 to make other measurements. System 1200 can be configured to operate in accordance with the teachings herein.

System 1200 can include a controller 1225, a memory 1230, an electronic

apparatus 1265, and a communications unit 1235. Controller 1225, memory 1230, and communications unit 1235 can be arranged to operate as a processing unit to control operation of tool 1205 having an arrangement of receiver sensors 1210 and to perform operations on the signals collected by tool 1205 to
5 determine a distance of tool 1205 to a conductive structure, such as a casing or other piping, in a manner similar or identical to the procedures discussed herein. Such a processing unit can be realized using a data processing unit 1220, which can be implemented as a single unit or distributed among the components of system 1200 including electronic apparatus 1265. Controller 1225 and memory
10 1230 can operate to control activation of transmitters/ receivers 1212 and selection of receiver sensors 1210 in tool 1205 and to manage processing schemes in accordance with measurement procedures and signal processing as described herein. Controller 1225 may control current generator 1207 to flow a current on the conductive structure whose position is to be determined. System
15 1200 can be structured to function in a manner similar to or identical to structures associated with Figures 1-11.

Communications unit 1235 can include downhole communications for appropriately located sensors. Such downhole communications can include a telemetry system. Communications unit 1235 may use combinations of wired
20 communication technologies and wireless technologies at frequencies that do not interfere with on-going measurements.

System 1200 can also include a bus 1227, where bus 1227 provides electrical conductivity among the components of system 1200. Bus 1227 can include an address bus, a data bus, and a control bus, each independently
25 configured or in an integrated format. Bus 1227 can be realized using a number of different communication mediums that allows for the distribution of components of system 1200. Use of bus 1227 may be regulated by controller 1225.

In various embodiments, peripheral devices 1245 can include additional
30 storage memory and/or other control devices that may operate in conjunction with controller 1225 and/or memory 1230. In an embodiment, controller 1225 is realized as a processor or a group of processors that may operate independently depending on an assigned function. Peripheral devices 1245 can be arranged

with one or more displays 1255, as a distributed component on the surface, that can be used with instructions stored in memory 1230 to implement a user interface to monitor the operation of tool 1205 and/or components distributed within system 1200. The user interface can be used to input operating parameter values such that system 1200 can operate autonomously substantially without user intervention.

Figure 13 depicts an embodiment of a system 1300 at a drilling site, where system 1300 includes a measurement tool 1305 configured with sensors and data processing unit, arranged to determine a conductive structure below the earth's surface based on magnetic-related measurements in response to current flowing on the conductive structure. The sensors can be arranged as one or more pairs of receiver sensors, where the two receiver sensors of each pair can be arranged orthogonal to each other. The structure on which the receiver sensors may be attached may be a drilling pipe. The conductive structure whose position is to be determined may include a casing of a well. System 1300 includes tool 1305 having arrangements of receivers, control unit, and data processing unit that can be realized in a similar or identical manner to arrangements discussed herein.

System 1300 can include a drilling rig 1302 located at a surface 1304 of a well 1306 and a string of drill pipes, that is, drill string 1319, connected together so as to form a drilling string that is lowered through a rotary table 1307 into a wellbore or borehole 1312. The drilling rig 1302 can provide support for drill string 1319. The drill string 1319 can operate to penetrate rotary table 1307 for drilling a borehole 1312 through subsurface formations 1314. The drill string 1319 can include drill pipe 1318 and a bottom hole assembly 1320 located at the lower portion of the drill pipe 1318.

The bottom hole assembly 1320 can include drill collar 1315, measurement tool 1305 attached to drill collar 1315, and a drill bit 1326. The drill bit 1326 can operate to create a borehole 1312 by penetrating the surface 1304 and subsurface formations 1314. Measurement tool 1305 can be structured for an implementation in the borehole of a well as a measurements-while-drilling (MWD) system such as a logging-while-drilling (LWD) system to detect a conductive structure such as a casing or other conductive structure. The

determination of the position of the conductive structure can be used to direct a drilling operation relative to the detected conductive structure. Measurement tool 1305 can be structured for an implementation in an offshore environment. The housing containing measurement tool 1305 can include electronics to collect
5 responses from receivers of measurement tool 1305. Such electronics can include a data processing unit to analyze signals sensed by measurement tool 1305 and provide measurement results, such as distance and direction from tool 1305 to a conductive structure, to the surface over a standard communication mechanism for operating a well. Alternatively, electronics can include a
10 communications interface to provide signals sensed by measurement tool 1305 to the surface over a standard communication mechanism for operating a well, where these sensed signals can be analyzed at a processing unit at the surface.

In various embodiments, measurement tool 1305 may be included in a tool body 1370 coupled to a logging cable 1374 such as, for example, for
15 wireline applications. Tool body 1370 containing measurement tool 1305 can include electronics to collect responses from receivers of measurement tool 1305. Such electronics can include a data processing unit to analyze signals sensed by measurement tool 1305 and provide measurement results, such as distance and direction from tool 1305 to a conductive structure, to the surface
20 over a standard communication mechanism for operating a well. Alternatively, electronics can include a communications interface to provide signals sensed by measurement tool 1305 to the surface over a standard communication mechanism for operating a well, where these collected sensed signals are analyzed at a processing unit at the surface. Logging cable 1374 may be realized
25 as a wireline (multiple power and communication lines), a mono-cable (a single conductor), and/or a slick-line (no conductors for power or communications), or other appropriate structure for use in bore hole 1312.

During drilling operations, the drill string 1319 can be rotated by the rotary table 1307. In addition to, or alternatively, the bottom hole assembly
30 1320 can also be rotated by a motor (e.g., a mud motor) that is located downhole. The drill collars 1315 can be used to add weight to the drill bit 1326. The drill collars 1315 also can stiffen the bottom hole assembly 1320 to allow the bottom hole assembly 1320 to transfer the added weight to the drill bit 1326, and in turn,

assist the drill bit 1326 in penetrating the surface 1304 and subsurface formations 1314.

During drilling operations, a mud pump 1332 can pump drilling fluid (sometimes known by those of skill in the art as “drilling mud”) from a mud pit 1334 through a hose 1336 into the drill pipe 1318 and down to the drill bit 1326. 5 The drilling fluid can flow out from the drill bit 1326 and be returned to the surface 1304 through an annular area 1340 between the drill pipe 1318 and the sides of the borehole 1312. The drilling fluid may then be returned to the mud pit 1334, where such fluid is filtered. In some embodiments, the drilling fluid 10 can be used to cool the drill bit 1326, as well as to provide lubrication for the drill bit 1326 during drilling operations. Additionally, the drilling fluid may be used to remove subsurface formation 1314 cuttings created by operating the drill bit 1326.

Although specific embodiments have been illustrated and described 15 herein, it will be appreciated by those of ordinary skill in the art that any arrangement that is calculated to achieve the same purpose may be substituted for the specific embodiments shown. Various embodiments use permutations and/or combinations of embodiments described herein. It is to be understood that the above description is intended to be illustrative, and not restrictive, and 20 that the phraseology or terminology employed herein is for the purpose of description. Combinations of the above embodiments and other embodiments will be apparent to those of skill in the art upon studying the above description.

PPH

CLAIMS:

1. A method comprising:
 - acquiring signals corresponding to received signals in two receiver sensors of a tool disposed below the earth's surface, the two receiver sensors arranged orthogonal to each other;
 - generating magnetic-related values from the acquired signals; and
 - processing the magnetic-related values to determine, relative to a tool structure to which the two receiver sensors are coupled, a position of a conductive structure from which the received signals were generated in response to current flowing on the conductive structure, including determining a distance (Dis) using a ratio related to minimum magnetic field measured and maximum magnetic field measured.
2. The method of claims 1, wherein processing the magnetic-related values includes calculating an azimuthal angle of the tool relative to the conductive structure based on the generated magnetic-related values.
3. The method of claim 1, wherein the method includes directly generating the current on the conductive structure.
4. The method of claim 1, wherein the method includes using two receiver coils on the tool oriented orthogonal to each other to collect the signals generated from the conductive structure.
5. The method of claim 1, wherein the method includes:
 - collecting the received signals at the two receiver sensors with the tool rotating;
 - associating the received signals with a bin of the tool, the bin corresponding to an angle of the tool when the signals are collected,
 - collecting additional received signals and assigning the additional received

PPH

signals to different bins, each bin corresponding to an azimuthal direction of the rotating tool; and

determining angular position of the conductive structure, relative to the structure to which the two receiver sensors are coupled, from determining which bin includes a largest absolute value of a difference between a maximum magnetic-related value derived from the received signal in the respective bin and an average magnetic-related value.

6. The method of claim 1, wherein determining the position of the conductive structure includes determining, with no current on the tool structure and with value of the current on the conductive structure unknown, the distance (Dis) using the ratio related to minimum magnetic field measured, $H_{Minimum}$, and maximum magnetic field measured, $H_{Maximum}$.

7. The method of claim 6, wherein Dis given by $Dis = k_1 \frac{(1 + \alpha_1) \cdot D}{1 - \alpha_1}$ where

$\alpha_1 = abs\left(\frac{H_{Minimum}}{H_{Maximum}}\right)$, or $Dis = k_1 \frac{(\alpha_2 + 1) \cdot D}{\alpha_2 - 1}$ where D is distance between center of

the two receiver sensors and center of the tool structure to which the two receiver

sensors are coupled, $\alpha_2 = abs\left(\frac{H_{Maximum}}{H_{Minimum}}\right)$ and k_1 is a calibration constant such that Dis

is determined by one of $(1 - \alpha_1)$ or $(\alpha_2 - 1)$ that is greater than zero.

8. The method of claim 1, wherein determining the position of the conductive structure includes determining, with current on the tool structure, the distance (Dis) using the ratio related to minimum magnetic field measured, $H_{Minimum}$, and maximum magnetic field measured, $H_{Maximum}$.

PPH

9. The method of claim 8, wherein, Dis given by $Dis = k_4 \frac{(1 + \alpha_1) \cdot D}{1 - \alpha_1}$ where

$$\alpha_1 = abs\left(\frac{H_{Minimum} - H_{Average}}{H_{Maximum} - H_{Average}}\right), \text{ or } Dis = k_4 \frac{(1 + \alpha_2) \cdot D}{\alpha_2 - 1}, \text{ where D is distance between}$$

center of the two receiver sensors and center of the tool structure to which the two

receiver sensors are coupled, $\alpha_2 = abs\left(\frac{H_{Maximum} - H_{Average}}{H_{Minimum} - H_{Average}}\right)$ and k_4 is a calibration

constant such that Dis is determined by one of $(1 - \alpha_1)$ or $(\alpha_2 - 1)$ that is greater than zero.

10. The method of claim 1, wherein the method includes:

collecting the received signals at the two receiver sensors with the tool in a non-rotating mode;

generating the magnetic-related values based on the received signals as orthogonal magnetic-related component values; and

calculating the angular position of the conductive structure relative to the tool using the orthogonal magnetic-related component values and a bin angle of the tool in the non-rotating mode.

11. The method of claim 10, wherein the angular position is provided by

$$\phi = \frac{\pi}{2} + \tan^{-1}\left(\frac{H_y}{H_x}\right), \text{ for } H_x > 0 \text{ or } \phi = \frac{3\pi}{2} + \tan^{-1}\left(\frac{H_y}{H_x}\right), \text{ for } H_x < 0 \text{ where } H_y \text{ and } H_x$$

are y and x magnetic field components and are functions of the bin angle.

12. The method of claim 10, wherein determining the position includes

determining the distance (Dis) given by $Dis = k_3 \frac{I}{H_0}$, where $H_0 = \sqrt{H_x^2 + H_y^2}$ and

k_3 is a calibration constant, where H_y and H_x are y and x magnetic field components, based on an equivalent current on the conductive structure using the ratio of the minimum magnetic field measured and the maximum magnetic field measured.

PPH

13. The method of claim 1, wherein the method includes:

associating the received signals at the two receiver sensors with a bin angle of the tool, the bin angle corresponding to an angle of the tool when the signal is collected; and

performing an inversion process using a measured parameter of the received signals and the bin angle to generate an azimuthal angle of the tool with respect to the conductive structure.

14. The method of claim 13, wherein performing the inversion process includes using curve fitting functions

$$H_{\phi_{Bin}}^T = A_T \frac{\cos(\phi_{Bin} + \phi_0)}{\sqrt{dis^2 + D^2 - 2 \cdot dis \cdot D \cdot \cos(\phi_{Bin} + \phi_0)}} + B_T, \quad \text{for tangential direction}$$

measurements,

$$H_{\phi_{Bin}}^N = A_N \frac{\cos(\phi_{Bin} + \phi_0 + \frac{\pi}{2})}{\sqrt{dis^2 + D^2 - 2 \cdot dis \cdot D \cdot \cos(\phi_{Bin} + \phi_0)}} + B_N, \quad \text{for normal direction}$$

measurements, where B_T is an average tangential magnetic field, B_N is an average normal magnetic field, A_T and A_N are curve fitting coefficients, dis is the distance from the tool to the conductive structure, ϕ_{Bin} is bin angle, D is distance between center of the two receiver sensors and center of the tool structure to which the two receiver sensors are coupled, and ϕ_0 is azimuthal angle of the tool structure with respect to the conductive structure.

15. The method of claim 1, wherein the conductive structure includes a casing associated with a well and the tool structure is part of a drilling pipe.

16. The method of claim 1, wherein the method includes determining, relative to the tool structure to which the two receiver sensors are coupled, the position of the conductive structure with the tool structure, to which the two receiver sensors are coupled, oriented parallel with the conductive structure.

17. A machine-readable storage device having instructions stored thereon, which, when performed by a machine, cause the machine to perform operations, the operations comprising the method of any of claims 1 to 16.

18. A system comprising:

two receiver sensors of a tool structured to couple to a structure operable to be disposed below the earth's surface to receive signals in the two receiver sensors disposed below the earth's surface, the two receiver sensors arranged orthogonal to each other relative to the structure to which the two receiver sensors are coupled; and

a control unit operable to manage collection of received signals at the receiver sensors with respect to current flowing on a conductive structure below the earth's surface; and

a data processing unit to process the received signals to determine a position of the conductive structure including to determine distance using a ratio related to minimum magnetic field measured and maximum magnetic field measured.

19. The system of claim 18, wherein the system includes a current transmitter to flow current on the conductive structure.

20. The system of claim 18, wherein the data processing unit and the control unit are operable to generate magnetic-related values from the received signals; and to process the magnetic-related values to determine, relative to the structure to which the two receiver sensors are coupled, the position of the conductive structure from the magnetic-related values and a bin angle associated with the two receiver sensors.

21. The system of claim 18, wherein the receiver sensors includes two coils arranged orthogonal to each other.

22. The system of claim 18, wherein the system includes a machine-readable storage device having instructions stored thereon, which, when performed by the system, cause the system to perform operations, the operations comprising the

method of any of claims 1 to 16.

23. The system of claim 18, wherein the two receiver sensors, the control unit, and the data processing unit are configured to operate according to any of claims 1 to 16.

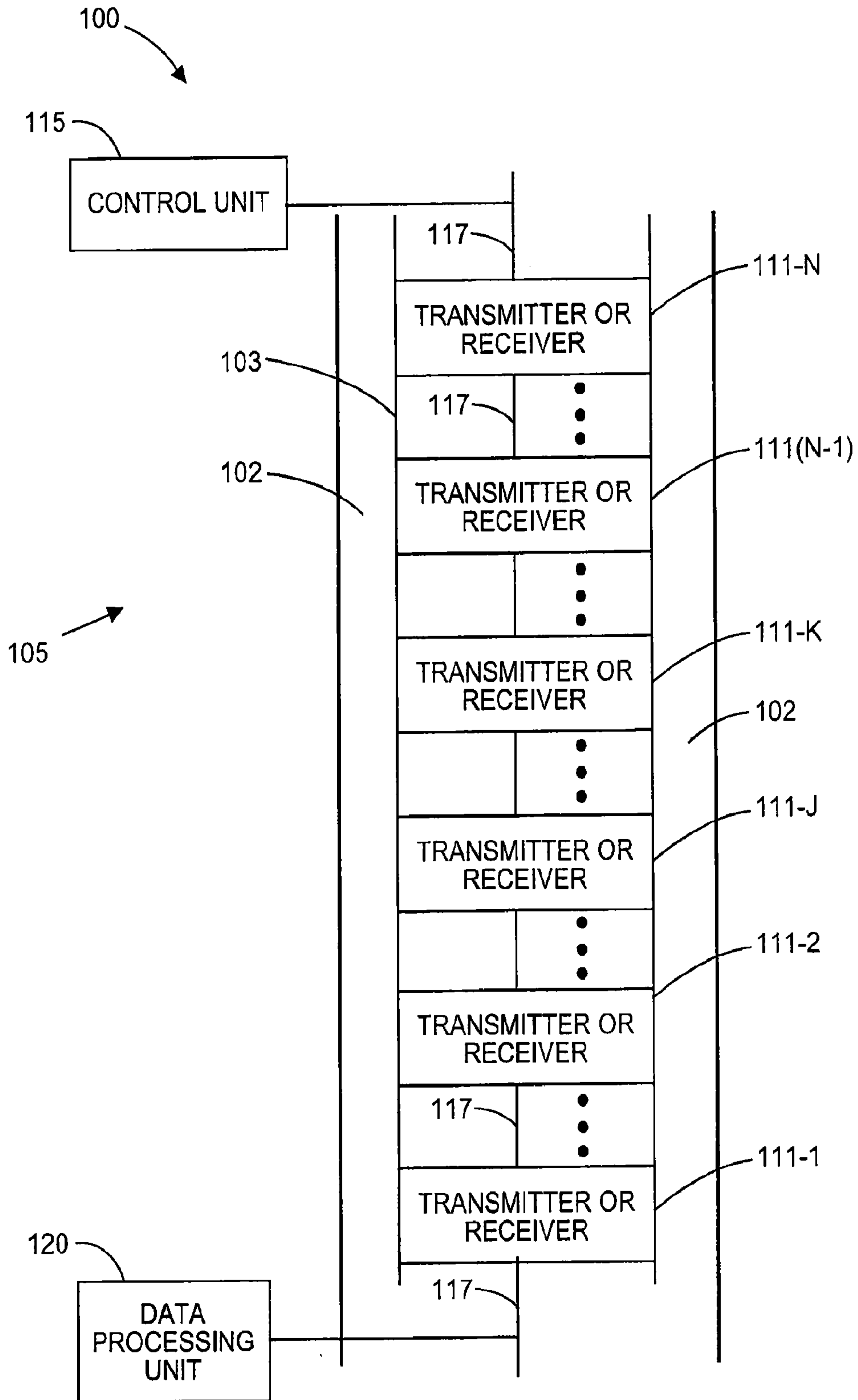
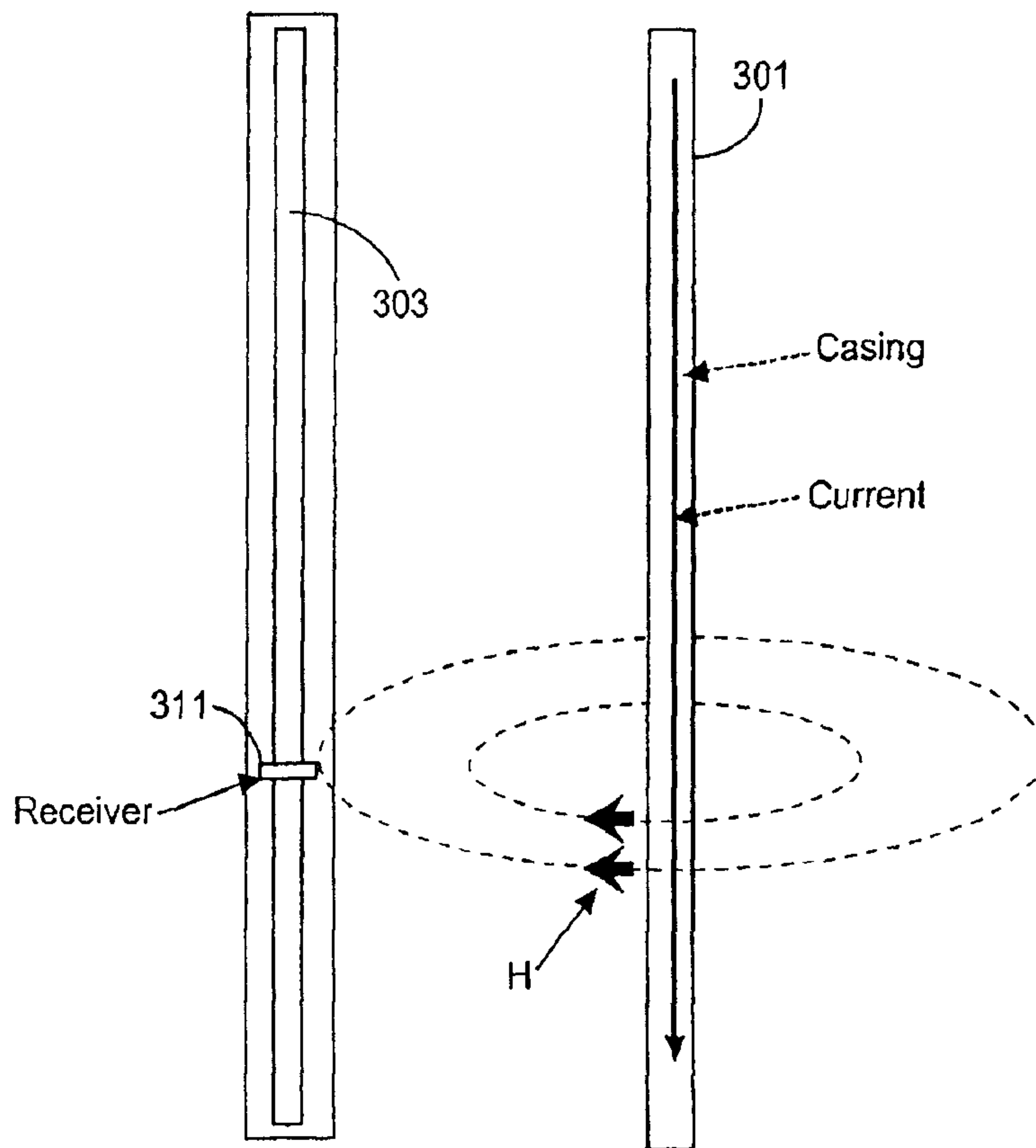
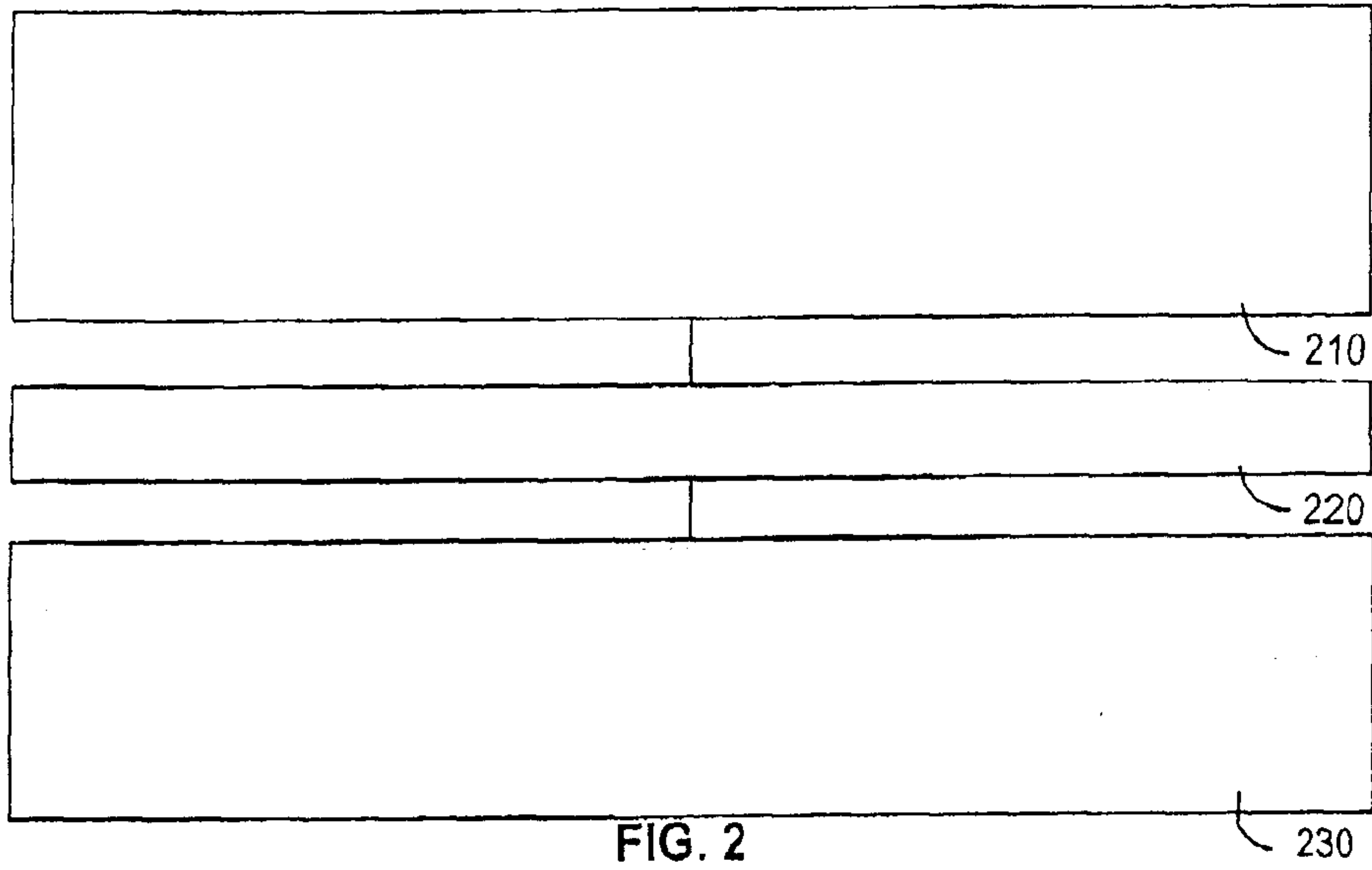

Fig.1



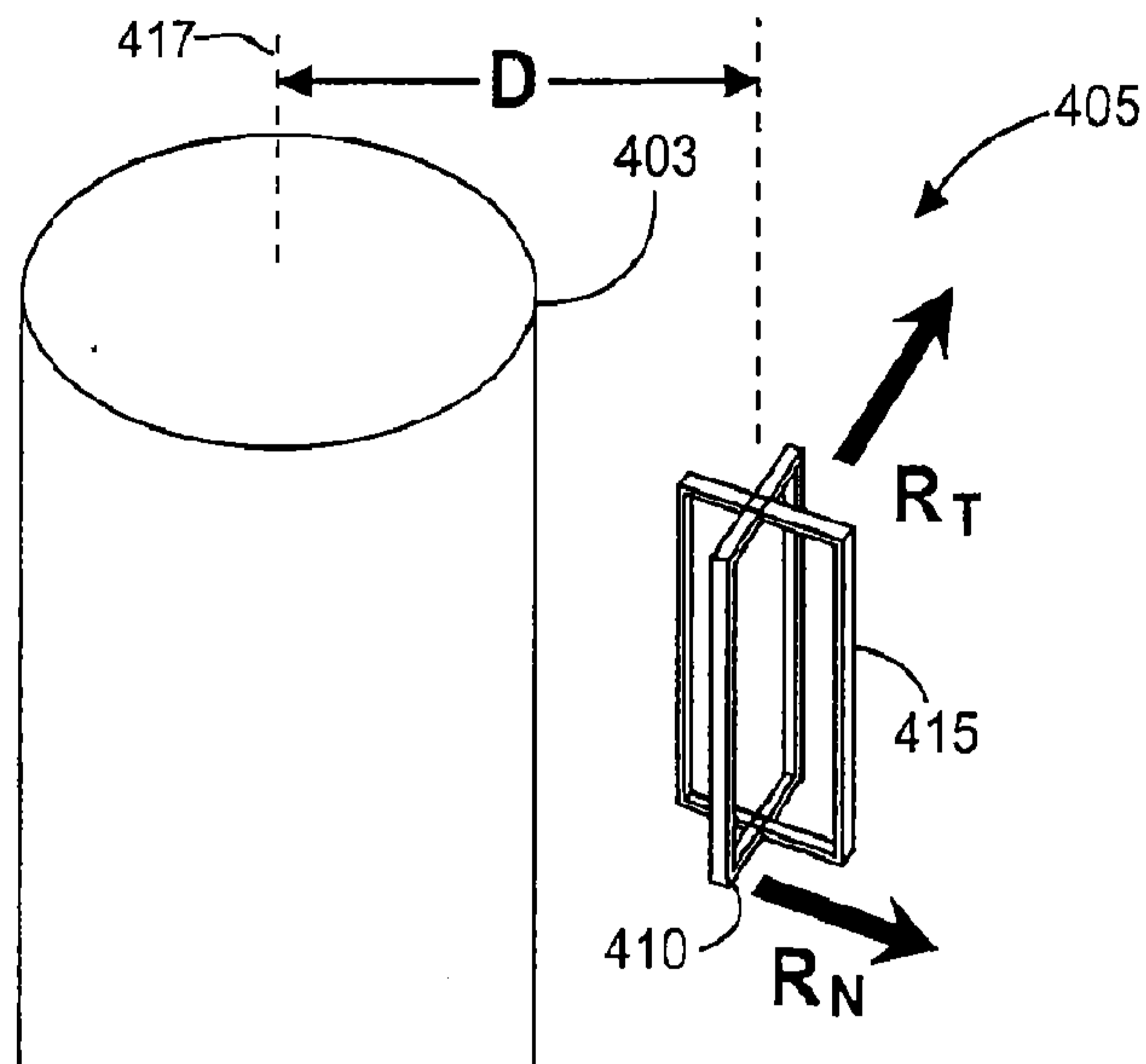

Fig. 4

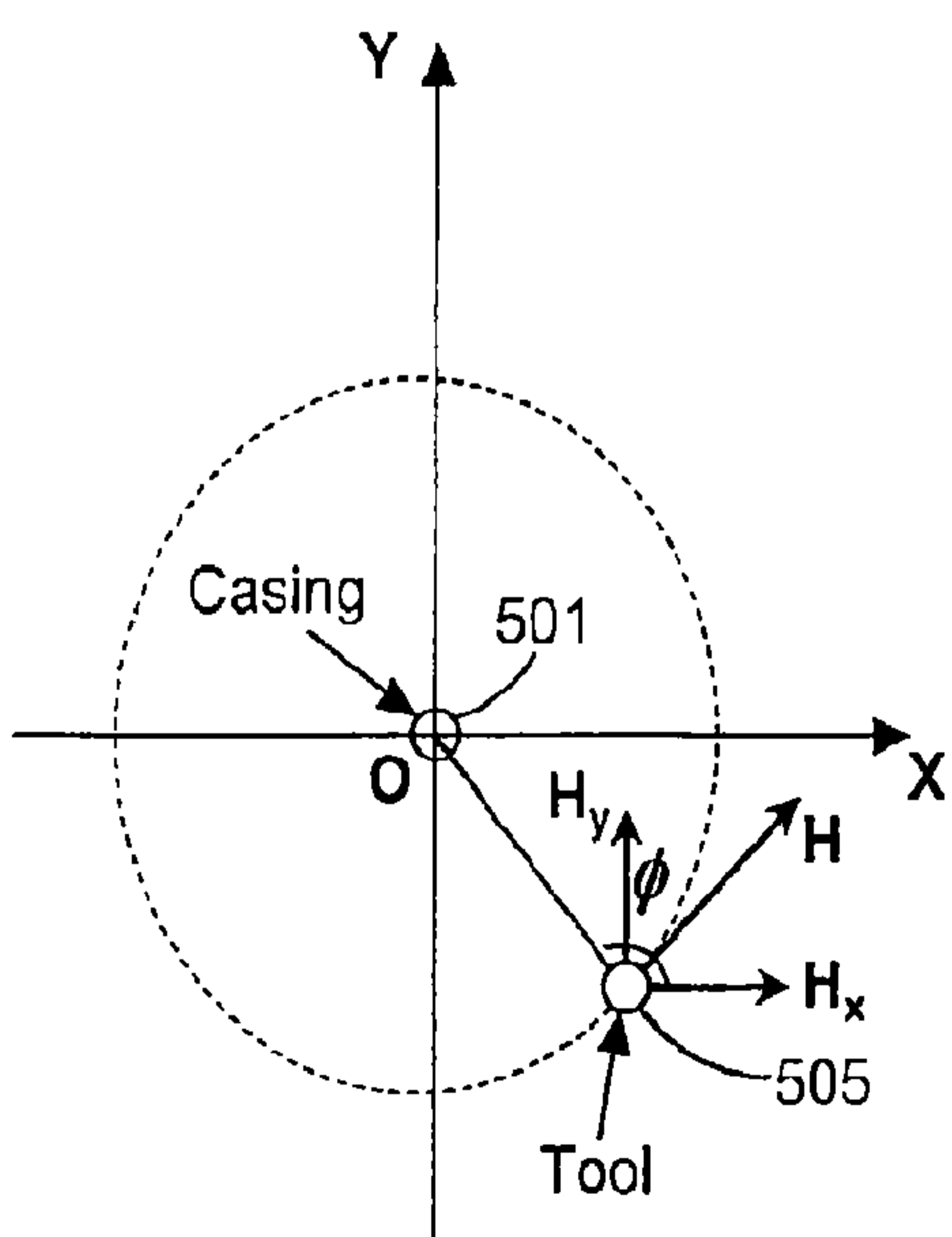

Fig. 5

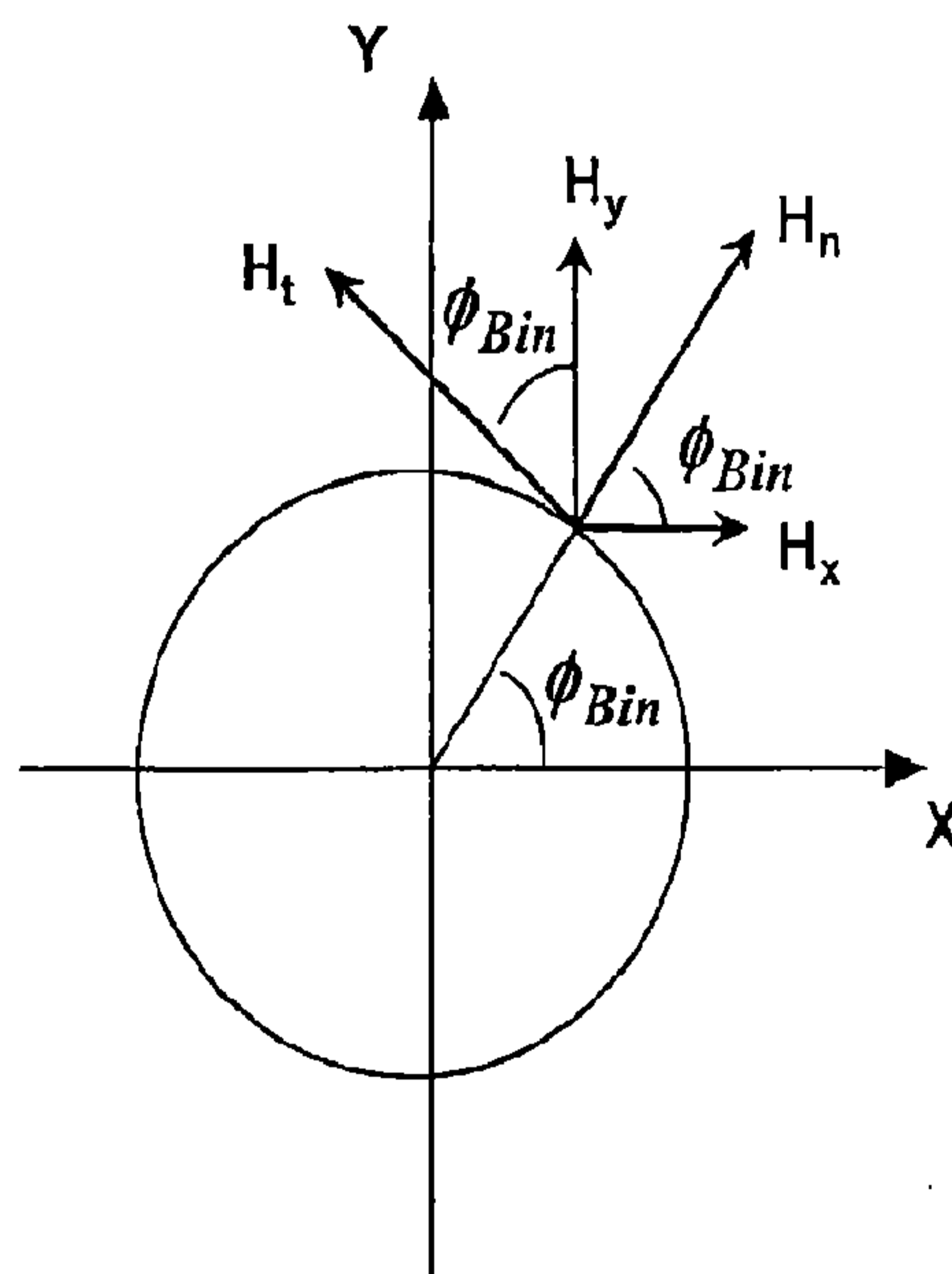

Fig. 6

4/8

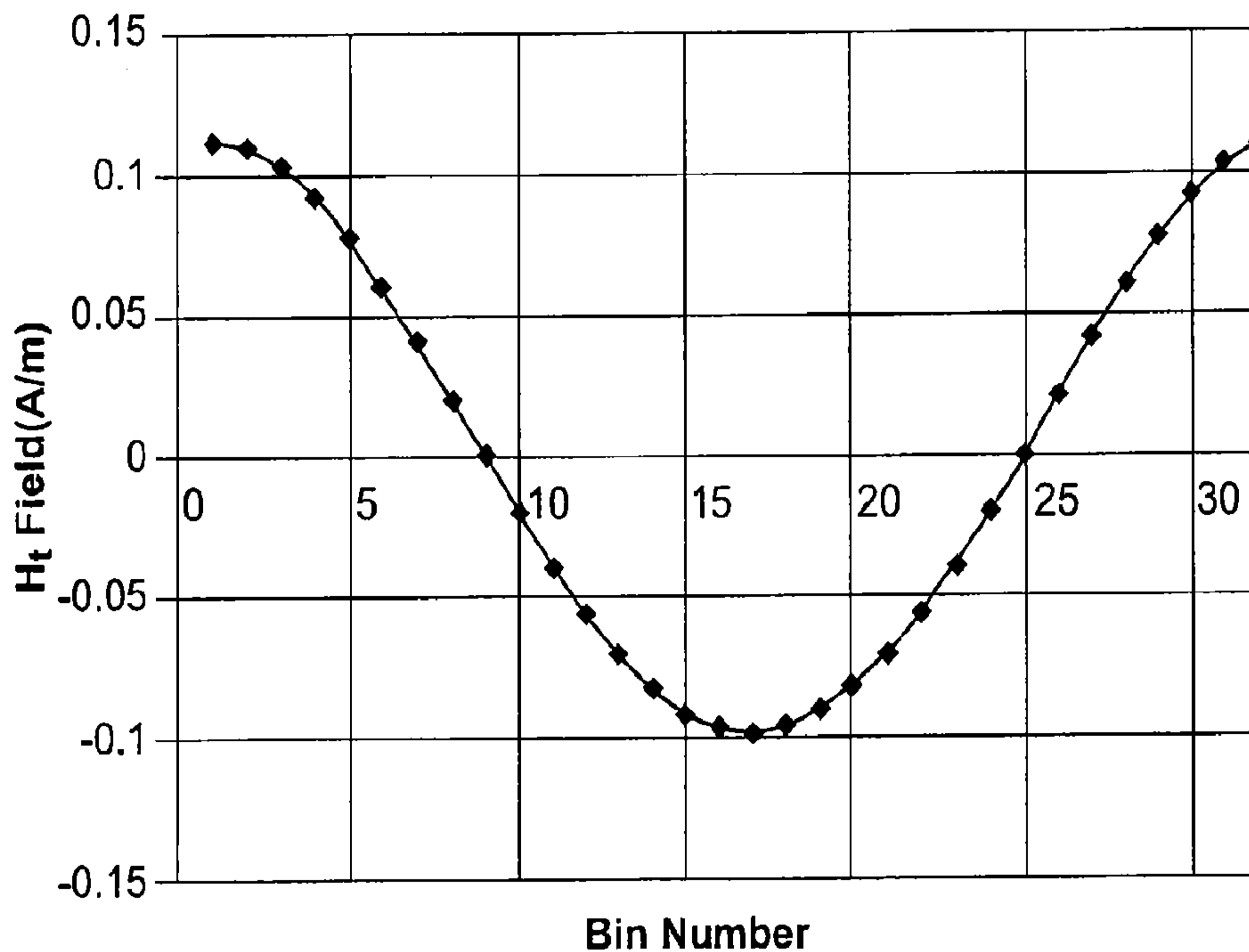

Fig. 7A

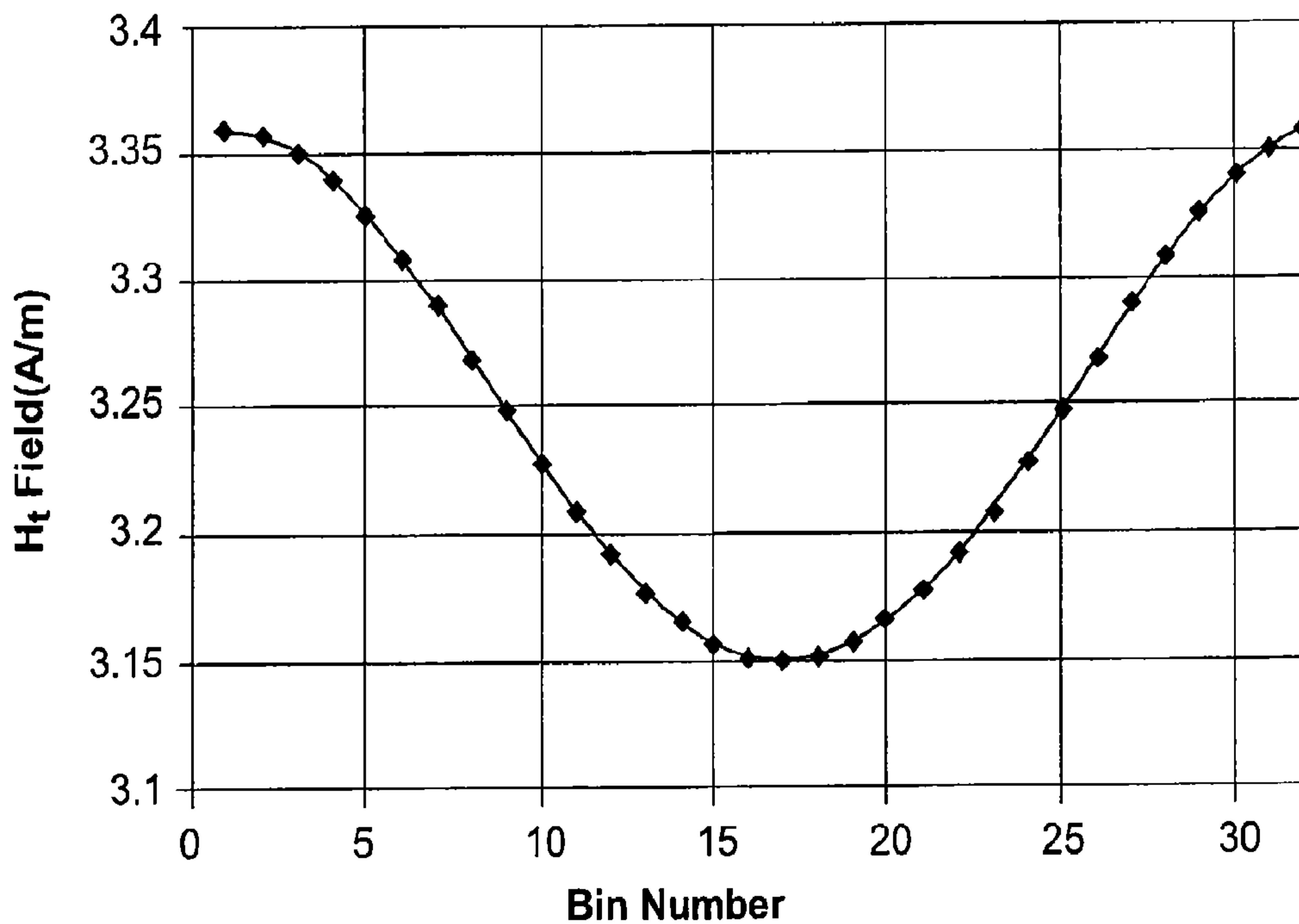

Fig. 7B

5/8

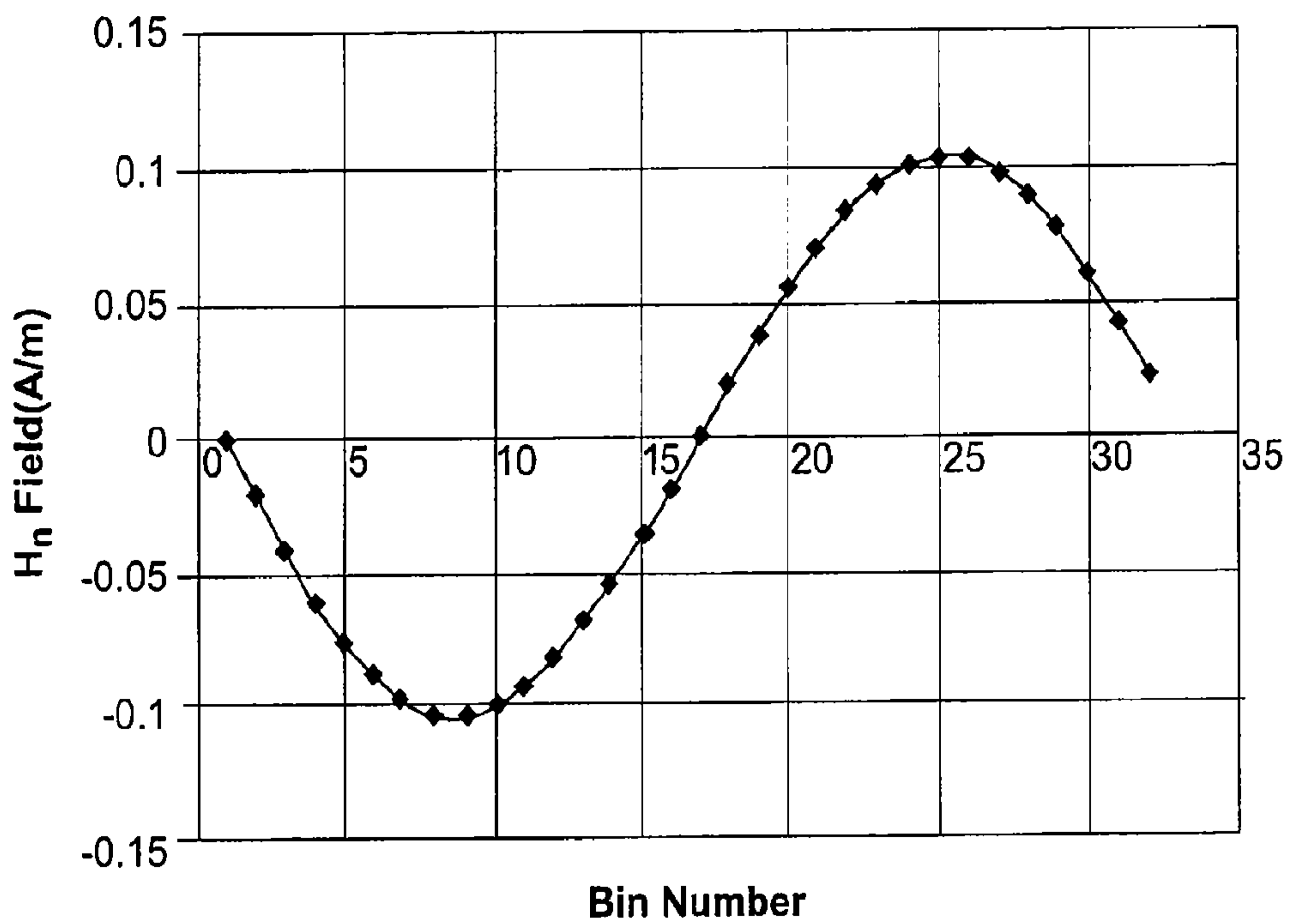

Fig. 8

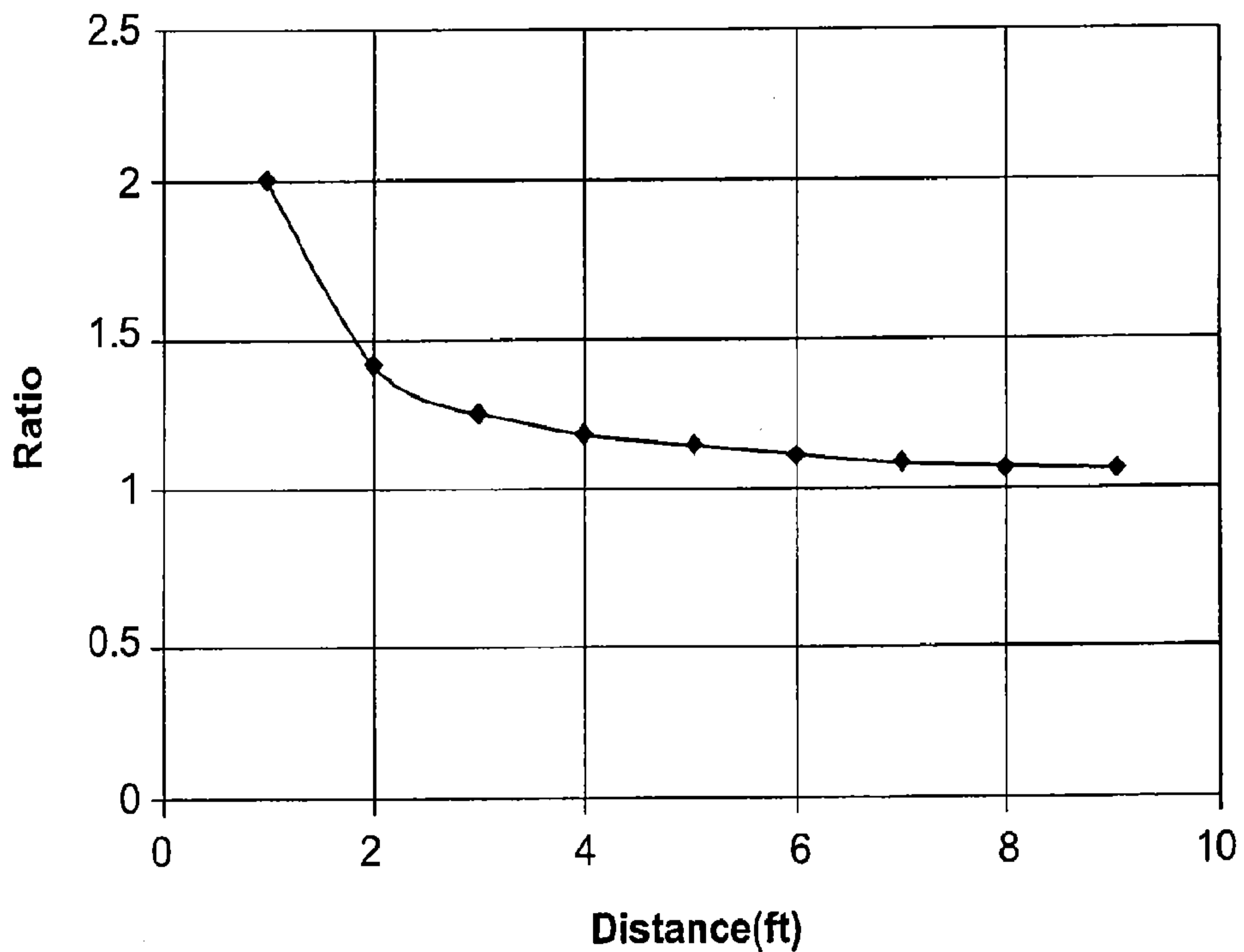

Fig. 9

6/8

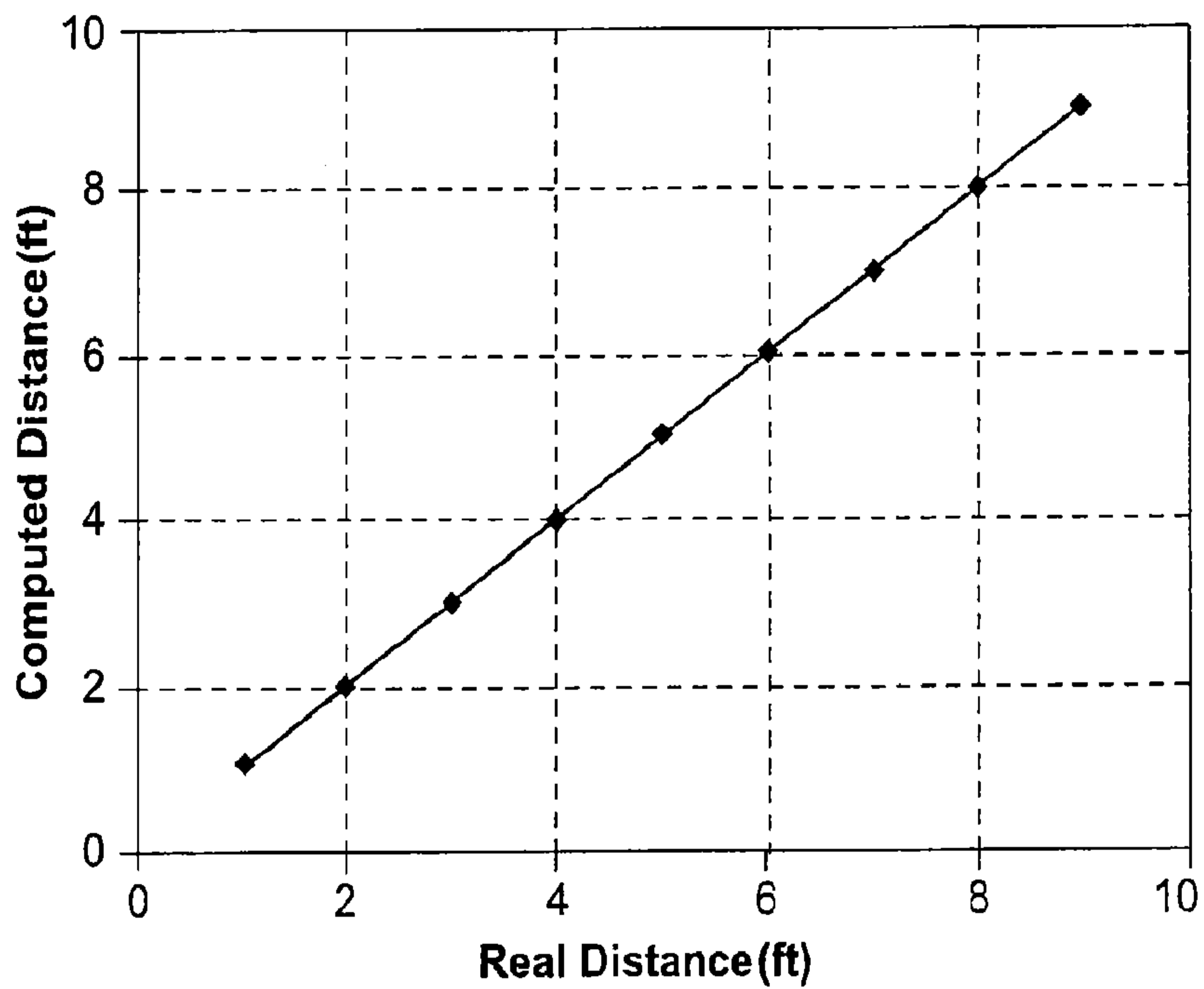

Fig. 10

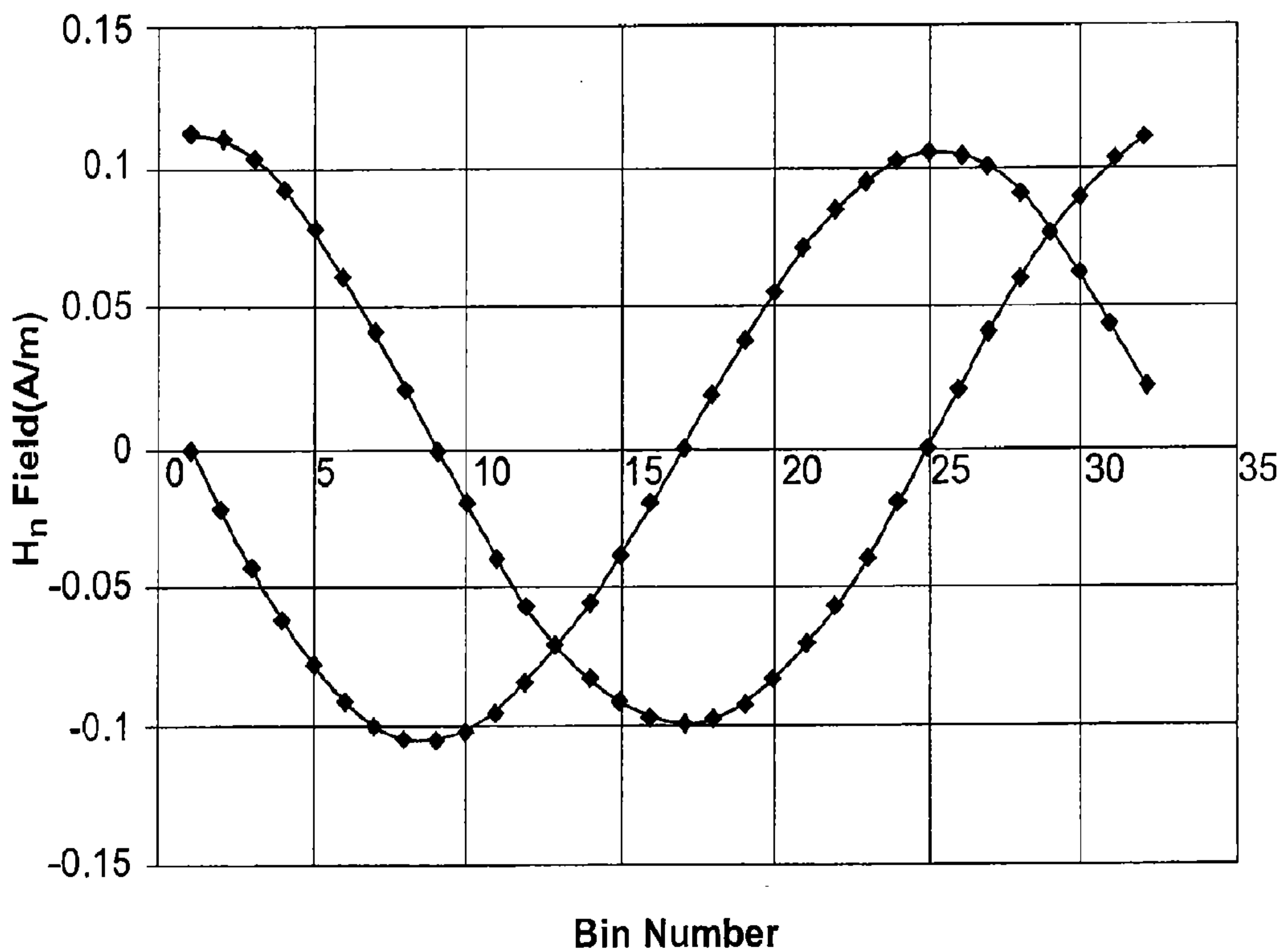

Fig. 11

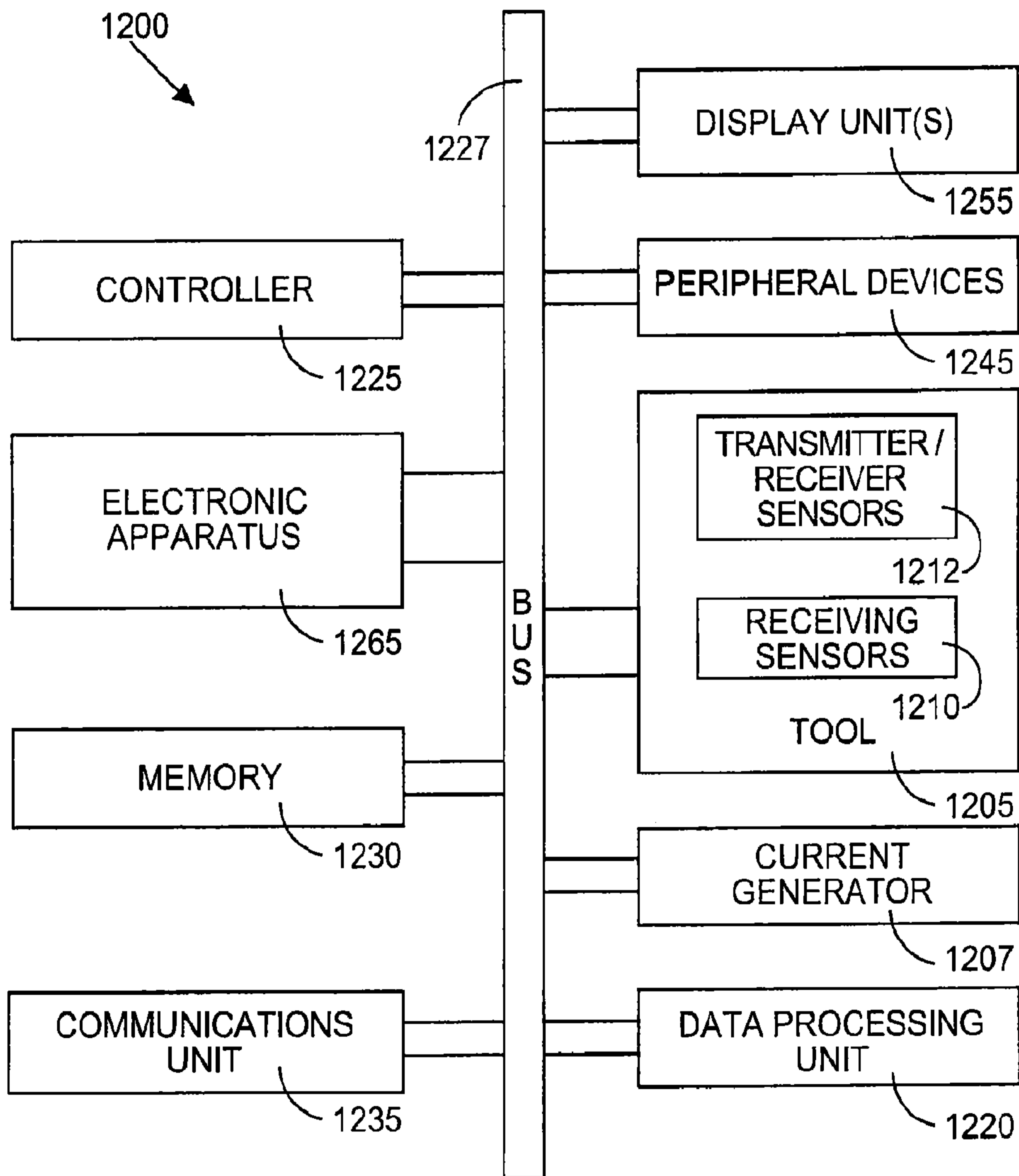

Fig.12

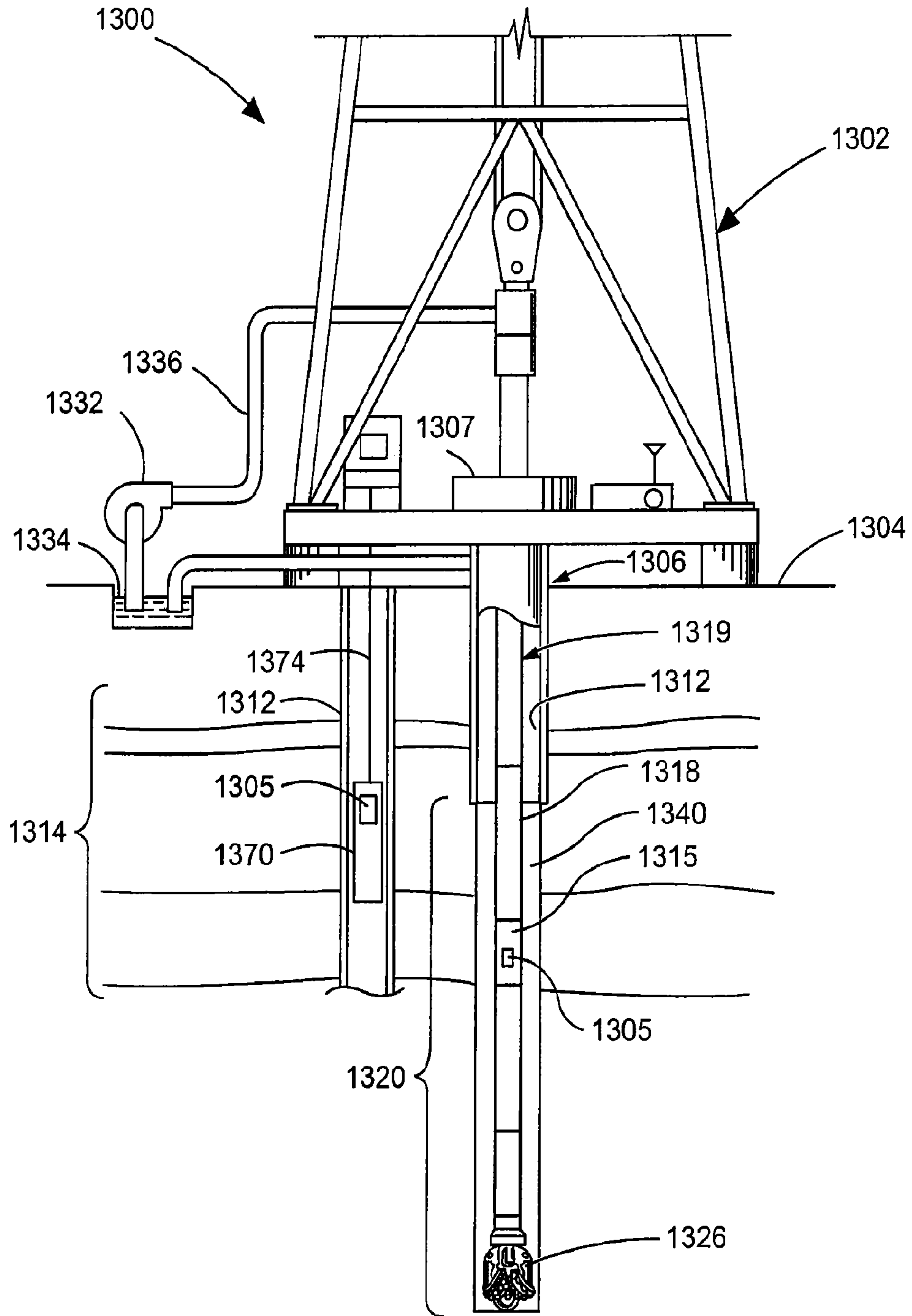

Fig. 13

