

(No Model.)

4 Sheets—Sheet 1.

F. W. DESSAU.  
STREET SWEEPER.

No. 526,222.

Patented Sept. 18, 1894.

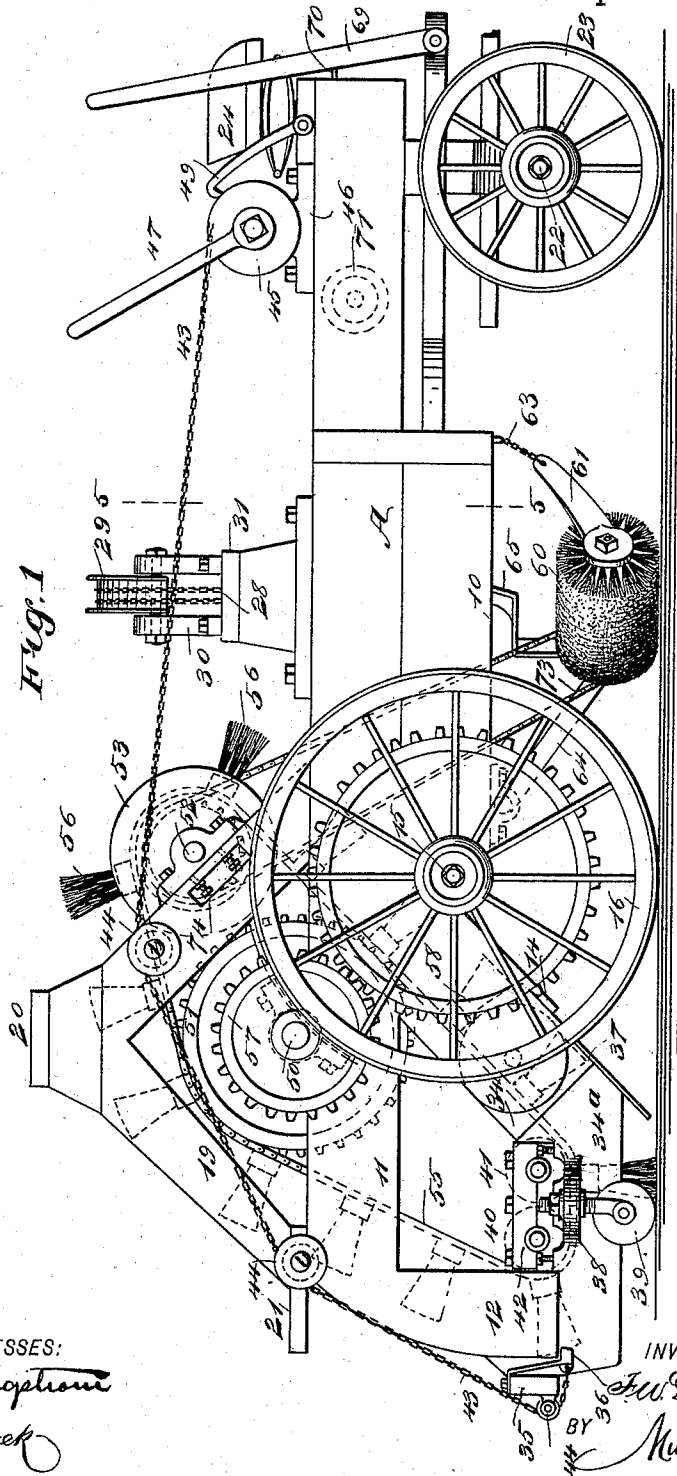

WITNESSES:  
*John Bergstrom*  
*C. Sadgwick*

INVENTOR  
*F. W. Dessau*  
 BY *Munn & Co.*

ATTORNEYS.

(No Model.)

4 Sheets—Sheet 2.

F. W. DESSAU.  
STREET SWEEPER.

No. 526,222.

Patented Sept. 18, 1894.

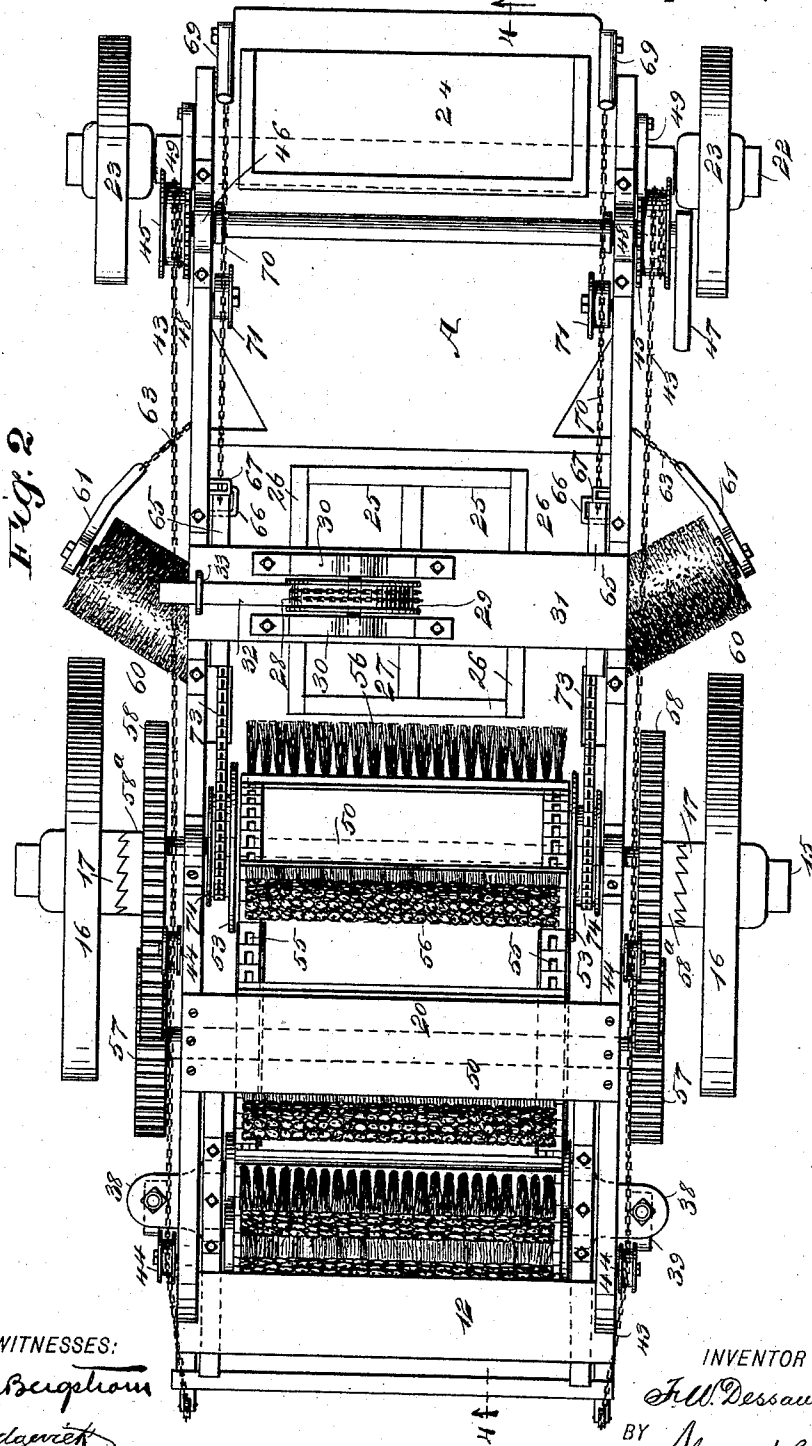

WITNESSES:  
*John A. Scribner*  
*C. Sedgwick*

INVENTOR  
*F. W. Dessau*  
BY  
*Munn & Co*  
ATTORNEYS.

F. W. DESSAU.  
STREET SWEEPER.

No. 526,222.

Patented Sept. 18, 1894.

Fig. 3

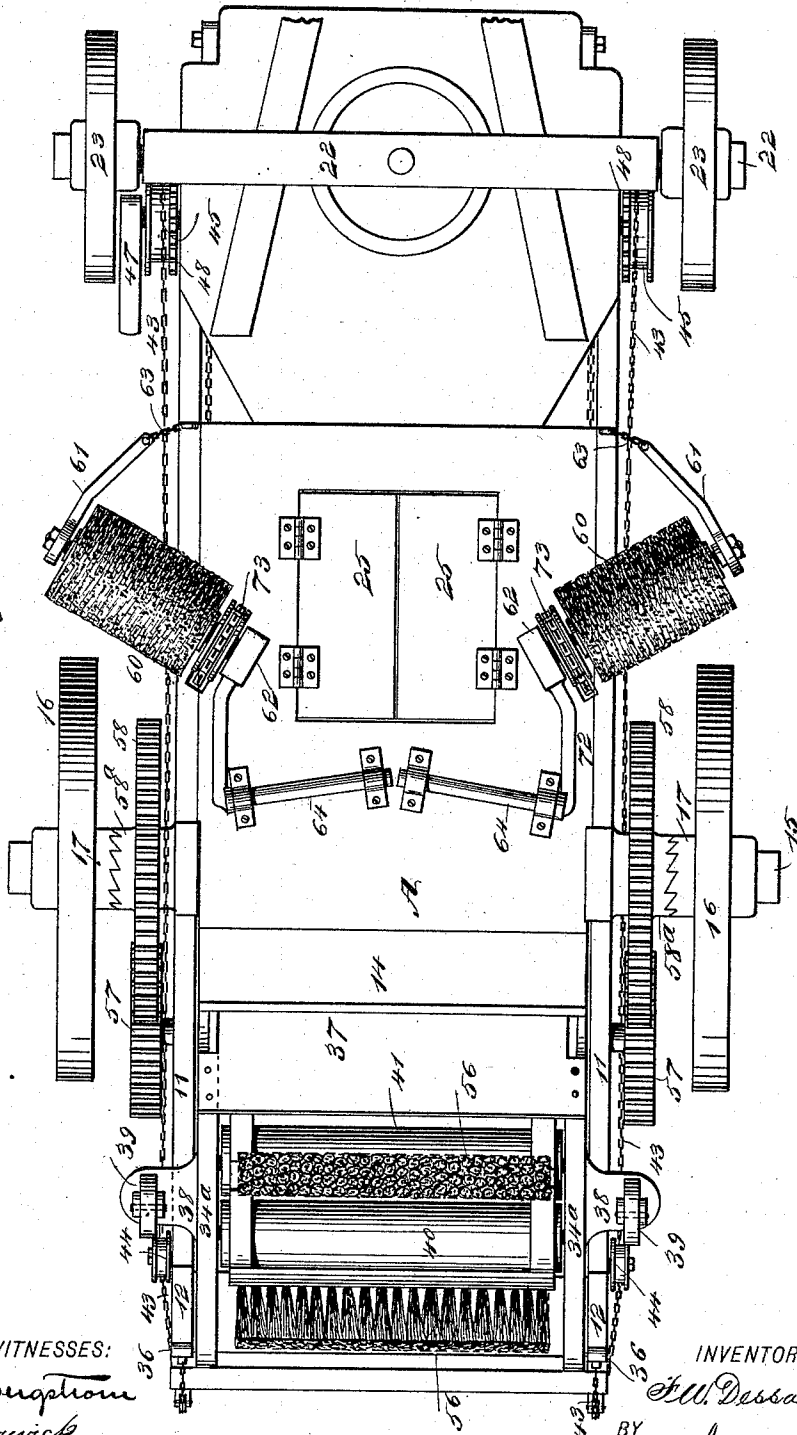

WITNESSES:  
*John A. Bingham*  
*Co. Sedgwick*

INVENTOR  
*F. W. Dessau*  
BY  
*Munn & Co*  
ATTORNEYS.



# UNITED STATES PATENT OFFICE.

FREDERICK W. DESSAU, OF AMSTERDAM, NEW YORK.

## STREET-SWEEPER.

SPECIFICATION forming part of Letters Patent No. 526,222, dated September 18, 1894.

Application filed March 5, 1894. Serial No. 502,386. (No model.)

### *To all whom it may concern:*

Be it known that I, FREDERICK W. DESSAU, of Amsterdam, in the county of Montgomery and State of New York, have invented a new and Improved Street-Sweeper, of which the following is a full, clear, and exact description.

My invention relates to an improvement in street sweepers, and it has for its object to provide a machine of simple, economic and durable construction, which will sweep the dirt from the street and deliver it into a vehicle of which the sweeping mechanism constitutes a part, and to provide a means for expeditiously and conveniently dumping said vehicle upon arriving at the proposed dumping place, and also to provide a means for readily elevating the sweeping mechanism from contact with the ground when the vehicle is to be driven to and from the surface to be swept.

Another object of the invention consists in locating the main set of brooms at the rear of the vehicle, and locating auxiliary brooms at each side of the vehicle at an angle thereto, the brooms being made to face the front yet incline inwardly, in order that a surface shall be swept of greater width than that of the vehicle, the side brooms delivering the sweepings in the path of the rear or main set of brooms, thereby providing for all of the sweepings to be conveyed into the vehicle body.

Another object of the invention is to provide for the manipulation of the side brooms independently of the rear set of brooms.

The invention consists in the novel construction and combination of the several parts, as will be hereinafter fully set forth and pointed out in the claims.

Reference is to be had to the accompanying drawings, forming a part of this specification, in which similar figures and letters of reference indicate corresponding parts in all the views.

Figure 1 is a side elevation of the sweeper. Fig. 2 is a plan view thereof. Fig. 3 is a bottom plan view. Fig. 4 is a longitudinal section taken practically on the line 4—4 of Fig. 2. Fig. 5 is a partial transverse section taken essentially on the line 5—5 of Fig. 1; and Fig. 6 is a side elevation of the movable

section of the elevator frame, the frame of the vehicle having been broken away.

In carrying out the invention a wagon body A, is utilized as the receiver of the sweepings, the said body being provided at its center with a well 10. The side pieces of the body are carried rearward to form horizontal extensions 11, from which branches 12 are projected vertically downward. The rear wall 13 of the well 10, is made to support an inclined board 14, which extends from a point within the well at the top downwardly and rearwardly below the bottom of the well. The rear of the vehicle is provided at each side with an axle 15, and a supporting wheel 16, is held to turn loosely upon each axle, said wheels being likewise adapted as drivers, being provided with clutch faces 17. Upon the rear upper portion of the vehicle opposing truss frames 19, are erected, connected by an upper cross bar 20, and a foot board 21, is formed at the rear lower portion of said frames. The forward axle 22 is pivotally connected with the body, and carries supporting wheels 23, smaller than the rear wheels 16.

The driver's seat 24, is located at the front and may be of any approved construction. The well has an opening formed in it, preferably in its center, which opening is closed by two doors 25, constructed to drop downward, and the margins of the opening which the doors are adapted to close are provided with guard strips 26, of metal or other material, and against which said doors close, while one door is provided with a guard strip 27, against which the opposing door closes, as shown in Figs. 2 and 5.

The doors are closed and held in closed position through the medium of chains 28, which are carried upward over a flanged segmental drum 29, mounted in bearings 30 located about centrally over the well and supported by a cross bar 31, apertured to permit the upward passage of the chains, said segmental drum being provided with a handle 32 and a latch 33 of any approved description, whereby it may be locked to the supporting bar or board 31 when the doors are closed.

Side boards 34, are secured to the main side boards of the vehicle body, and extend downward in contact with the inclined transverse board 14, forming virtually sides therefor.

These side boards constitute a fixed portion of an elevator frame, the other fixed portions thereof being the extensions 11 of the main sides of the body and the trusses 19. This elevator section is provided with a lower movable section 34<sup>a</sup>, comprising a horizontal member provided with an upward extension at its rear end, and an upward and forward extension at its forward end, the upward and forward extensions being pivotally connected with the side boards 34, and the rear upward extensions of the two movable sections 34<sup>a</sup> are connected by a rear cross bar 35, as is best shown in Figs. 1 and 4. This cross bar 35, is provided at each end with a latch 36, spring-controlled and adapted, when the movable sections of the elevator frame are in working position, to engage with the under edge of the rear extensions 12 of the body of the vehicle, as shown in Fig. 1, maintaining said section 34 in such position.

The frame of the elevator is completed by securing upon the upper face of the floor board 14 a metal plate 37, which extends from side to side of said floor board and downward within a predetermined distance of the ground, as is best shown in Fig. 4.

The movable sections of the elevator frame are provided upon the outer faces of their horizontal members with brackets 38, carrying caster wheels 39, which travel upon the ground and support said elevator frame when the machine is in working order. The movable sections of the elevator frame likewise carry two parallel and preferably somewhat closely grouped rollers 40 and 41, journaled in adjustable bearings 42 formed upon the upper portion of the horizontal member of said movable sections; and when the movable sections are elevated, the elevator carried by the frame will be so raised as to carry the brooms constituting a portion thereof from possible engagement with the ground. Such elevation is effected by attaching chains 43 to the latches 36, carrying the said chains over friction rollers 44 attached to the outside of the elevator frame to a connection with a drum 45, journaled in bearings 46 at the rear of the driver's seat. This drum is rotated preferably through the medium of a crank 47 placed at one end, and it is provided at the end to which the crank is applied with ratchet teeth 48, to receive a pawl 49.

The main driving shaft 50 of the elevator is journaled in adjustable bearings formed upon one of the extensions 11 of the sides of the vehicle body, the said shaft being provided within the elevator frame near each end with a sprocket wheel 51 of suitable size. A second shaft 52 is mounted in adjustable bearings upon the forward members of the trusses 19, as is shown in Figs. 1 and 4, and this shaft is provided with flanges 53, located just within the elevator framing, and sprockets 54, are secured upon the shaft adjacent to the inner face of each flange. The sprocket

wheels 51 and 54 carry endless chains 55, which are likewise passed over the rollers 40 and 41 in the adjustable section of the framing, and these endless chains are connected by the heads of brushes 56 which are secured to the chains, and the said brushes together with the chains constitute the elevator above referred to, since when the machine is in operation the brushes 56 will engage one after the other with the ground, and sweep any loose material in front of them on to the plate 37 extending downward from the floor board 14; and the brushes by contacting with the said plate and floor board, as they are carried upward, will carry with them the sweepings, and brush said sweepings over the top of the floor board into the well 10 of the vehicle. When the pivoted sections of the elevator frame are raised upward by the chains 43, the endless belts will be carried upward likewise to such an extent as to carry the brushes out of possible contact with the ground.

The driving shaft 50 is driven preferably by securing upon each end a gear 57, which meshes with a larger gear 58 loosely mounted upon each axle 15 and provided with a clutch face 58<sup>a</sup>, engaging with the corresponding faces of the hubs of the rear wheels 16, the clutch faces being so constructed that the said wheels 16 will act as drivers for the gears 58 when the machine is drawn forwardly, but when the machine is backed for any purpose the clutch faces will slide by one another and the wheels 16 will have no action upon the said gears 58. Preferably a plate 59, is attached to each of the pivoted side sections of the elevator framing, as shown in Fig. 6, and said plates will then close the opening which would otherwise exist at the rear side portions of the machine, and will prevent the escape of dust, confining the sweepings entirely to the plate 37 and floor board 14. A single broom 60, preferably of a cylindrical character, is located partially beneath and partially outside the sides of the vehicle body in front of the rear wheels 16 and said side brooms are given an inclination in a forward and inward direction, that is to say, their outer ends are nearer the front axle than their inner ends. These side brooms are mounted to turn in bearings 61 and 62, the bearing 61 being provided with an upward extension connected by a chain 63 preferably with the forward portion of the well, while each inner bearing 62 is connected with the lower end of a crank shaft 64, said shafts being journaled in suitable bearings upon the bottom of the well, as shown best in Fig. 3. Thus it will be observed that the side brooms may be raised and lowered, their own weight bringing them down to sweeping position; but in order that they shall not rise to any appreciable extent when lowered for service, an arm 65, of spring material is connected with the inner bearing 62, of each of said brooms, as shown in Fig. 4. These arms extend upward and preferably

curve forwardly in the well 10, being located one at each side thereof, and the arms 65 pass through staples 66, located near their upper ends, a stop 67 being located adjacent to the upper end of each arm, as is also shown in Fig. 4.

The arms 65 are normally held against the rear member of the guide staples 66 through the medium of springs 68, and when the side brooms are to be elevated, levers 69 journaled upon the front of the vehicle body adjacent to the driver's seat, are pushed in a forward direction, said levers being connected by chains 70 with the upper portions of the spring arms 65, and when forward tension is brought to bear upon said arms their springs 68 will be compressed and their upper ends may readily pass the stops 67. The chains 70 pass over suitable guide pulleys 71. The brushes 60 are provided at one end with a sprocket wheel 72, over which runs a sprocket chain 73 to and over a sprocket wheel 74 on the shaft 52 of the elevator, as shown in Figs. 1, 2, and 4. From the foregoing description it is evident that each side broom may be manipulated independently, and both side brooms independently of the elevator.

By reason of the shafts 50 and 52 and the rollers 40 and 41 being mounted in adjustable bearings, the endless broom carrying belt 55 may be adjusted in direction of the floor board 14 to compensate for the wear upon the brooms.

Having thus described my invention, I claim as new and desire to secure by Letters Patent—

1. In a street sweeper, the combination with a wagon having a downwardly inclined portion at the rear end of its body and provided with a horizontal extension projecting from the body, of a frame hinged to the said inclined portion within the horizontal extension, rollers mounted in the said frame, sprocket wheels mounted upon supports carried by the wagon body, an endless chain of brushes passing over the sprocket wheels and the rollers, gearing for operating the endless chain of brushes as the wagon moves forward, means for raising the frame, and a locking device for locking the frame to the said horizontal extension, substantially as described.

2. In a street sweeper, the combination with a wagon having a downwardly inclined portion at the rear end of its body, and provided with a horizontal extension projecting from the body, of a wheeled frame hinged to the said inclined portion, within the horizontal extension, rollers mounted in the frame, sprocket wheels mounted in supports carried by the wagon body, endless chains passing over the sprocket wheels and the rollers of the hinged frame, brush heads secured to and connecting the said chains, gearing for oper-

ating the endless chain of brushes as the wagon moves forward, a catch for locking the frame to the horizontal extension, and means for releasing the catch and raising the frame, substantially as described.

3. In a streetsweeper, the combination with a wagon having a downwardly inclined portion at the rear end of its body, and provided with a horizontal extension projecting from the body and having downwardly extending outer ends, of a wheeled frame hinged to the inclined portion within the horizontal extension, rollers mounted in the frame, sprocket wheels mounted in supports carried by the wagon body, endless chain of brushes passing over the sprocket wheels and the rollers of the hinged frame, gearing for operating the endless chain of brushes as the wagon moves forward, spring latches secured to the hinged frame and adapted to engage the downwardly extending ends of the horizontal extensions, and chains secured to the latches and extending to the forward part of the wagon, whereby the latches can be disengaged and the frame raised, substantially as described.

4. In a streetsweeper, the combination with a wagon body provided with downwardly inclined side boards, and horizontal extensions having downwardly projecting branches, of a wheeled frame hinged to the said side boards and provided with rollers over which a brush elevator passes, latches secured to the hinged frame and adapted to engage the branches of the said extension, chains having one end secured to the latches, and a drum mounted on the wagon body and to which the other ends of the said chains are attached, substantially as described.

5. In a street sweeper, the combination with a wagon body, of a bearing secured to a crank shaft mounted on the under side of the body, a second bearing provided with an extension connected to the wagon body by a chain, a brush mounted in the bearings, means for operating the brush, a spring pressed arm connected with one bearing and projecting through a guide, and a stop adjacent to the upper end of said arm, substantially as described.

6. In a street sweeper, the combination with a wagon body, of a bearing secured to a crank shaft mounted on the under side of the wagon body, a second bearing provided with an extension connected to the wagon body by a chain, a brush mounted in the bearings, means for operating the brush, a spring pressed arm connected with the inner bearing, a pivoted lever, and a chain connected to the lever and to the said arm, substantially as described.

FREDERICK W. DESSAU.

Witnesses:

GUSTAV A. DESSAU,  
HUNRI FIRORH.