

M. FROESÉ.  
ASH SIFTER.

APPLICATION FILED FEB. 8, 1908.

917,042.

Patented Apr. 6, 1909.

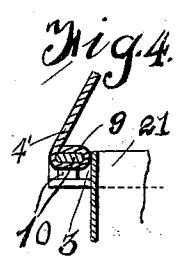
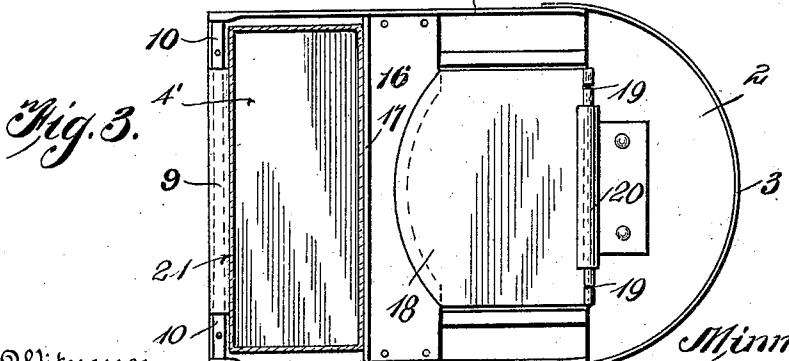
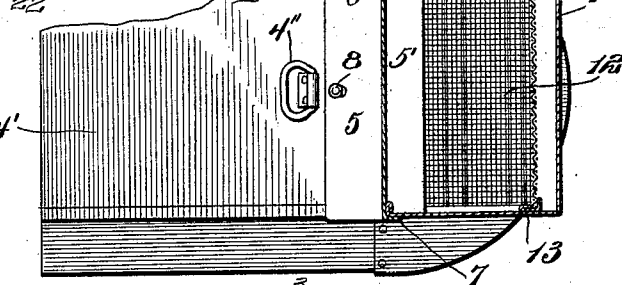
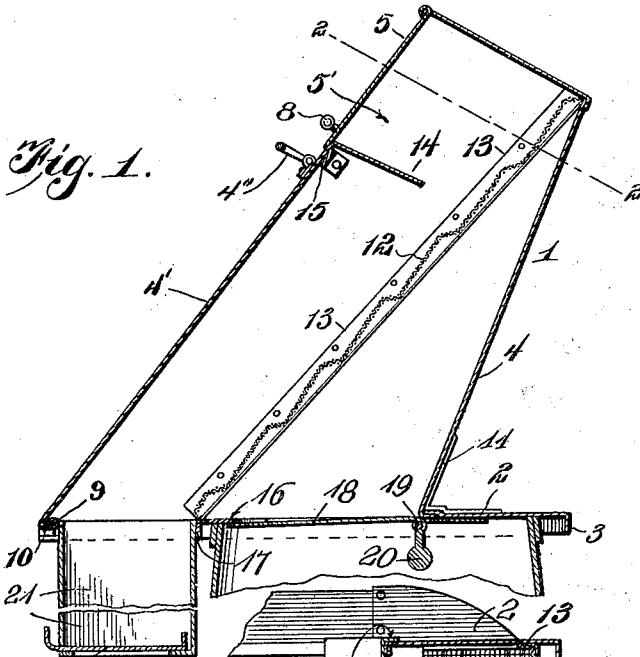

Witnesses  
Louis P. Heinrichs  
C. H. Griesbauer

Inventor  
Mima Froesé  
By H. B. Wilson & Co.  
Attorneys

# UNITED STATES PATENT OFFICE.

MINNA FROESÉ, OF NEW YORK, N. Y.

ASH-SIFTER.

No. 917,042.

Specification of Letters Patent.

Patented April 6, 1909.

Application filed February 8, 1908. Serial No. 414,938.

*To all whom it may concern:*

Be it known that I, MINNA FROESÉ, a citizen of the United States, residing at New York, in the county of New York and State of New York, have invented certain new and useful Improvements in Ash-Sifters; and I do declare the following to be a full, clear, and exact description of the invention, such as will enable others skilled in the art to which it appertains to make and use the same.

This invention relates to improvements in self-operating ash sifters.

The object of the invention is to provide a sifter with means to adapt it to fit closely over barrels or other receptacles of various sizes and so constructed as to prevent the escape of dust during the sifting operation, and by means of which the ashes deposited therein will be thoroughly separated from the cinders.

A further object is to provide a sifter so constructed and braced as to render it very strong and durable.

In the accompanying drawings; Figure 1 represents a longitudinal section of the sifter arranged in operative position on a barrel. Fig. 2 is a transverse section thereof; and Fig. 3 is a bottom plan view of the sifter. Fig. 4 is a detail sectional view on an enlarged scale.

In the embodiment illustrated, a sifter 1 is shown having a base plate 2 of approximately U-shaped form with a rectangular opening or cut-out portion, whereby the curved end thereof is of greater width than the sides, and is designed to adapt the plate to fit over larger or smaller sized cans or barrels. On the outer edges of the sides and curved end of this base plate is arranged a depending flange 3 to form stops for limiting the movement of said plate on the barrel.

An upwardly projecting inclined chute 4 of any desired height and size is fitted and secured at its lower end in said rectangular opening in the base plate and preferably tapers toward its closed upper end. A hinged upwardly opening door 5 is arranged to close an opening 5' provided at the upper end of the long inclined front wall 4' of the chute 4 and is provided at its opposite side edges with inwardly projecting or down-turned flanges 6 and 7, which fit snugly against the outer sides of the chute and hold the door tightly closed to prevent escape of dust when the sifter is in operation.

The door is preferably provided with a knob 8 to facilitate the opening and closing thereof. A bail-shaped handle 4'' is preferably secured to the front 4' of the chute 4 by means of which the sifter may be moved and which may be used also as a means for suspending it from a suitable support when not in use. The inclined front 4' of the chute extends flush with the free ends of the base plate 2 and its lower edge is preferably bent inwardly to form a keeper 9 for a stiffening rod or brace 10 which extends through said keeper and across the lower side of the ends of the plate 2 and is secured thereto preferably by rivets. The ends of this rod or bar 10 are preferably bent downward and secured in pockets formed by the up-turning of the edges of the depending flanges 3 formed on the outer edges of the sides of said plate 2. The front wall 4' of the chute thus connects and braces the free ends of the legs of the U-shaped plate, the rod 10 serves as an additional brace therefor, and the ends being bent at right angles and disposed in pockets formed by the flanges of the plate are prevented from being forced through said plate.

An L-shaped brace 11 is preferably secured to the outer face of the rear wall of the chute 4 and to the base plate 2 by rivets or other suitable means to prevent bending and bulging of the chute at this point.

The upper end of the inclined front 4' of the chute 4 is bent inwardly at the lower edge of the door opening to form a deflecting plate 14 which extends preferably about one half of the way across the chute and against which the ashes thrown in through the door opening strike and rebound onto a screen hereinafter described, so that all of the ashes and cinders must pass over the entire length of the screen before being deposited into their respective receptacles. A stiffening brace 15 is secured to the inner face of said front wall 4' of the chute 4 at the point of bending of the deflecting plate and the ends of this brace are bent at an angle and riveted to the side walls of the chute. This brace forms a support on which a hod, shovel or the like may rest when emptying ashes into the sifter.

Arranged within the chute 4 is a longitudinally disposed inclined screen 12, the upper end of which is secured to the inner wall of the rear side of the chute adjacent to the upper end thereof. This screen 12 may be made of any suitable material and secured to

the chute in any desired manner, but is here shown constructed of wide mesh heavy screen wire, transversely corrugated, and having its edges bound by metal strips 13.

5 The side edges of this screen 12 are preferably bent at right angles to the body thereof and riveted or otherwise secured to the sides of the chute 4.

A transversely disposed plate 16 is secured at its opposite ends to the under side of the base plate 2 about mid-way of the opening therein and the front and rear edges of this plate 16 are preferably hollowed out or cut away to provide an unobstructed passage 15 for the cinders and ashes to the receptacles arranged below. This plate 16 is provided with a depending flange or rib 17 extending preferably the entire length thereof to provide a stop against which the upper edges of the adjacent ash and cinder receptacles abut, whereby the movement of the sifter on said receptacles is limited and the inward movement of the barrels or receptacles relatively to the sifter is limited to prevent the slipping 25 of the ash receptacle under the cinder compartment and vice versa.

The sifter constructed as herein shown and described will be self-operating and will thoroughly separate the ashes from the cinders thrown therein. By providing the door 5 and arranging it as herein shown and described the ashes may be readily deposited into the chute from a hod or other receptacle or thrown therein with the shovel, the deflecting plate in the upper end of the chute preventing the ashes from being thrown too far into the chute before coming into engagement with the shifting screen as herein before described. This plate also serves to deflect the dust rising through the screen.

Arranged within the chute 4 at the lower end thereof beneath the screen 12 to close the opening through which the sifted ashes pass to the ash receptacle, is an automatically operated downwardly opening closure or cover 18 for said opening, preferably constructed as shown in Fig. 1. This closure 18 as shown is pivoted at 19 to the rear wall of the chute 4 and a weight 20 is carried by said closure 18 to normally hold it in closed position with its free edge in engagement with the lower face of the plate 16, which limits its upward movement. This weight also quickly closes the cover 18 after the 55 ashes have passed through the opening, and thereby prevents dust from rising from the barrel through the opening and passing out through the door 5.

The cinder compartment of the chute 4 is preferably provided at its lower end with a receptacle 21 which forms an extension of said compartment to receive the cinders and it may be made integral with the chute or not as desired. This cinder receptacle 21 may be made of any desired shape and size and is preferably provided with a sliding closure 22 at its lower end which may be opened when the cinders are desired to be removed from said receptacle.

Various changes in the form, proportion and the minor details of construction may be resorted to without departing from the principle or sacrificing any of the advantages of the invention, as defined in the appended claims. 75

I claim as my invention:—

1. An ash sifter comprising a chute having an approximately U-shaped base plate member having a cross plate arranged between its side members approximately midway the length of its opening, the front portion of said chute extending flush with the spaced-apart end portions of said base plate and having a keeper formed at its lower forward edge, and a brace rod extending through said keeper and having its end portion bent downwardly and said base plate having depending flanges forming pockets at their forward edges receiving said downwardly bent portions of said brace rod. 80 85 90

2. An ash sifter comprising a chute having a base plate of approximately U shape, a cross plate between the side members thereof about midway the length of its opening, the front portion of the chute extending flush with the spaced-apart end members of said base plate and having a keeper formed at its lower forward edge and a brace rod extending through said keeper and having its end portions bent downwardly, said base plate having depending flanges forming pockets at their forward edges to receive said downwardly bent portions of said brace rod, said cross plate having a pendent flange upon its inner side to form a stop and cinder and ash receptacles having their upper edges arranged to engage said stop. 95 100 105

In testimony whereof I have hereunto set my hand in presence of two subscribing witnesses. 110

MINNA FROESÉ.

Witnesses:

H. B. WILLSON,  
E. EDMONSTON, Jr.