

(No Model.)

W. DIEBEL.
SHAFT HANGER.

No. 524,315.

Patented Aug. 14, 1894.

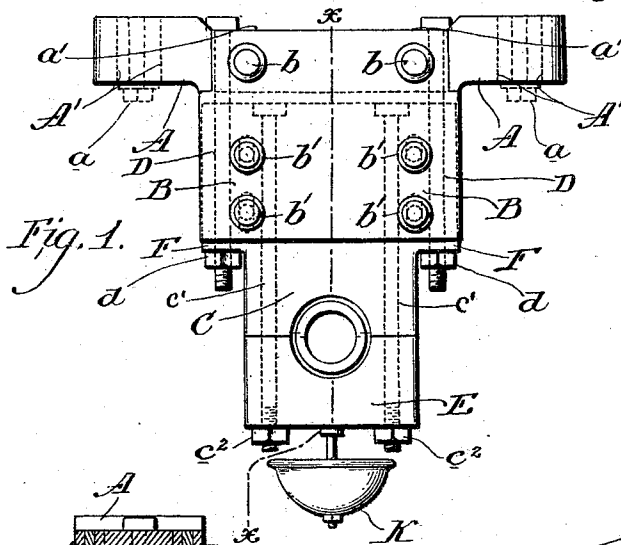

Fig. 1.

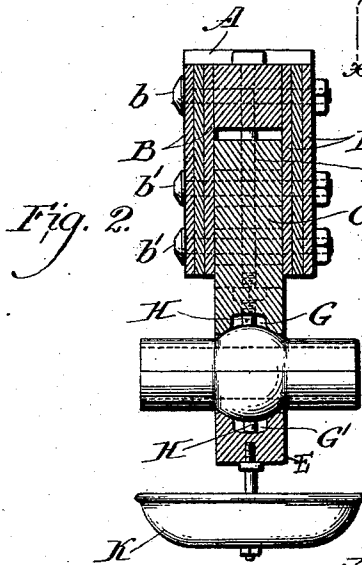

Fig. 2.

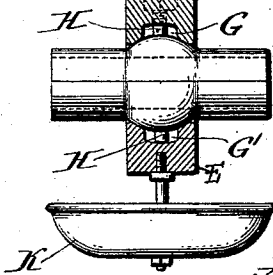

Fig. 3.

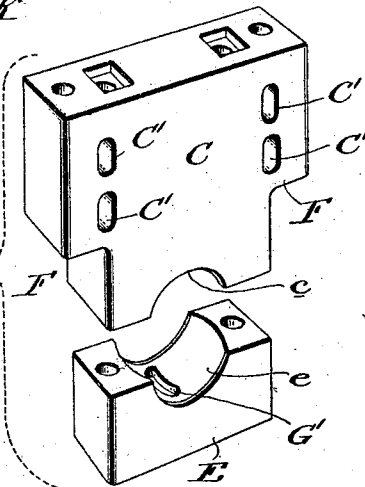
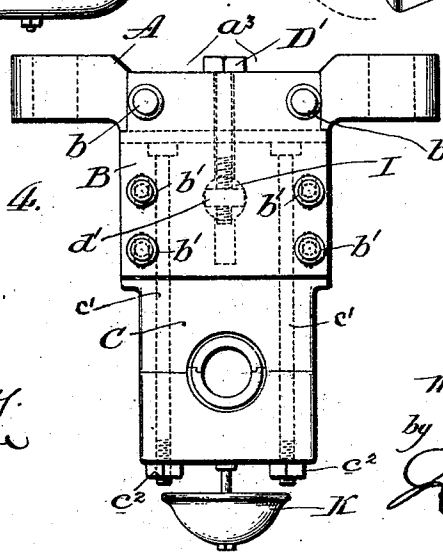

Fig. 4.



WITNESSES:
George F. Drury.
Albert J. Martin

INVENTOR:
William Diebel
by his Attorney
Paul Williams & Co.

UNITED STATES PATENT OFFICE.

WILLIAM DIEBEL, OF PHILADELPHIA, PENNSYLVANIA.

SHAFT-HANGER.

SPECIFICATION forming part of Letters Patent No. 524,315, dated August 14, 1894.

Application filed March 29, 1894. Serial No. 505,521. (No model.)

To all whom it may concern:

Be it known that I, WILLIAM DIEBEL, a citizen of the United States, residing at Philadelphia, county of Philadelphia, and State of Pennsylvania, have invented a new and useful Improvement in Shaft-Hangers, of which the following is a full, clear, and exact description, reference being had to the accompanying drawings, which form a part of this specification.

My invention is designed primarily to cheapen the construction of a shaft hanger by so constructing and arranging the several parts as to enable the hanger to be made almost wholly out of wood, without, however, sacrificing its strength. As is well known, shaft hangers are ordinarily made from cast or wrought iron, as wooden hangers have generally been found to be lacking in requisite strength and durability. Nor have wooden hangers been heretofore made of different parts relatively adjustable. To carry out my invention, however, I have constructed a hanger with adjustable parts and have fashioned each of the several parts so that the grain will run in a particular direction calculated to enable the piece to resist the special strain to which it is subjected, and then have so arranged the parts relatively to one another that adjoining parts will strengthen each other and the hanger as a whole be practically equal, or superior in power to resist strain and support the shaft, to a metallic hanger. At the same time, it is neither large nor cumbersome, but on the contrary, neat and compact.

My invention consists also, in means for adjusting the hanger vertically and laterally, and in the particular construction and combination of parts in which my invention is preferably embodied.

In the drawings:—Figure 1 is a view in side elevation of the hanger, the several parts being attached together and the journal boxes in place. Fig. 2 is a section on the line $x-x$ of Fig. 1. Fig. 3 is a detached perspective view of a portion of the hanger shown in Fig. 1; and Fig. 4 is a view in side elevation of the hanger, showing modified means for effecting vertical adjustment.

A is the supporting block, inset on opposite sides to receive depending cheek pieces B.

C is the middle section of the hanger, which is adapted to be confined between and secured to the cheek pieces B, and E is a cap adapted to be secured to the lower end of section C, the semi-spherical concavities c and e , in the section C and cap E respectively, forming a universal socket for the journal boxes of the shaft.

The mode of suspending the hanger and attaching the several parts together is as follows: The supporting block A has slots A', through which bolts a extend into the beam or joist of the ceiling. The block A is also provided with holes through which extend the bolts b , which aid in securing the cheek pieces B and block A together. The section C has slots C', through which the bolts b' extend, whereby said sections are secured to the cheek pieces. Bolts c' extend down through the section C into and through the cap E, the nuts c'' serving to clamp the cap against the lower part of the section C.

In my preferred construction, the section C is widened out at its upper portion, forming the offset part F. Bolts D, the heads of which lie in the recessed portion a' of the supporting block A, extend down through the same into and through said offset part. By means of the nuts d beneath the offset part F, the section C may be raised or lowered relative to the block A, the slots C' permitting this vertical adjustment to the extent of their length. The slots A' in the supporting block enable the hanger to be adjusted longitudinally.

The journal box has a free universal movement, but is prevented from turning in the hanger by means of the pins or projections H, which are free to play back and forth in the grooves G and G' in the section C and cap E, respectively. This admits of a true leveling of the shaft in the box, which facilitates adjustment and enables the shafting to adjust itself in true alignment.

Instead of constructing the section C with offset part F and extending the adjustable bolts through the latter, I can use the modification shown in Fig. 4, wherein the block A is provided with the recessed portion a'' , a bolt D' extending therefrom through block A and section C to the opening I, in which, surrounding the bottom of the bolt, is the nut d' .

By turning the head of the bolt D', the nut being confined from moving vertically, adjustment of section C is readily effected.

An important feature of my construction consists in the way the several parts are fashioned relative to the grain of the wood. In the block A and section E, for instance, the grain runs horizontally, while in the section C the grain runs vertically. In all three pieces it will be observed that the grain runs lengthwise, and that the grain in adjoining pieces runs in opposite directions.

I prefer to construct the rectangular cheek pieces, which are substantially square in shape, in three layers, the outer layers of which have their grain running vertically, while the middle layer has its grain running horizontally.

The drip pan K is secured to the hanger in any suitable manner. I have shown the drip provided with a central threaded orifice engaging a threaded rod depending from the hanger.

By suitable modifications that will suggest themselves to the skilled mechanic the hanger may be modified to serve as a post hanger as well as a drop hanger.

Having now fully described my invention, what I claim, and desire to protect by Letters Patent, is—

1. A shaft hanger consisting of the combination of a supporting block adapted to be secured to a permanent support, said block having depending cheek pieces, a middle section, a cap adapted to be secured thereto, said middle section and cap forming together a socket for the journal box, said middle section being interposed between and secured to said cheek pieces so as to be vertically adjustable thereupon substantially as described.

2. In a shaft hanger, in combination, a sup-

porting block adapted to be secured to a permanent support and horizontally adjustable thereon, said block having depending cheek pieces, middle section, a cap adapted to be secured thereto, said middle section and cap forming together a socket for the journal box, said middle section being interposed between and secured to said cheek pieces, substantially as described.

3. In a shaft hanger, in combination, a supporting block adapted to be secured to a permanent support, said block having depending cheek pieces, a middle section, a cap adapted to be secured thereto, said middle section and cap forming together a socket for the journal box, said middle section being interposed between and adjustably secured to said cheek pieces, and an independently adjustable connection between said block and middle section, substantially as described.

4. In a shaft hanger, in combination, a supporting block adapted to be secured to a permanent support and longitudinally adjustable thereon, said block having depending cheek pieces, a middle section interposed between said cheek pieces, a cap adapted to be secured to said middle section, said middle section and cap forming together a socket for the journal box, holes extending through said cheek pieces into vertical slots in the middle section, and a bolt extending through said middle section into a vertical hole in the supporting block, and a nut on said last named bolt for vertically adjusting the same, substantially as described.

In testimony of which invention I have hereunto set my hand.

WM. DIEBEL.

Witnesses:

J. E. CARPENTER,
A. J. MARTIN.