

(19) World Intellectual Property
Organization
International Bureau



(43) International Publication Date
15 September 2005 (15.09.2005)

PCT

(10) International Publication Number
WO 2005/084136 A2

- (51) International Patent Classification: **Not classified**
- (21) International Application Number:
PCT/IL2005/000269
- (22) International Filing Date: 7 March 2005 (07.03.2005)
- (25) Filing Language: English
- (26) Publication Language: English
- (30) Priority Data:
10/797,278 10 March 2004 (10.03.2004) US
- (71) Applicant (for all designated States except US): **R & D SUPPORTS** [IL/IL]; 99 Hahistadrut St., 31250 Haifa (IL).
- (71) Applicants and
(72) Inventors: **REIS, Daniel** [IL/IL]; 9 Taashur St., 34656 Haifa (IL). **ZUCKER, Dalia** [IL/IL]; 199(a) Derech Hayam St., 34890 Haifa (IL). **BIN NUN, Asher** [IL/IL]; 11 Ayah St., 21721 Carmiel (IL).
- (74) Agent: **APPELFELD ZER LAW OFFICE**; 29 Lilinblum, 65133 Tel-aviv (IL).
- (81) Designated States (unless otherwise indicated, for every kind of national protection available): AE, AG, AL, AM, AT, AU, AZ, BA, BB, BG, BR, BW, BY, BZ, CA, CH, CN, CO, CR, CU, CZ, DE, DK, DM, DZ, EC, EE, EG, ES, FI, GB, GD, GE, GH, GM, HR, HU, ID, IL, IN, IS, JP, KE, KG, KP, KR, KZ, LC, LK, LR, LS, LT, LU, LV, MA, MD, MG, MK, MN, MW, MX, MZ, NA, NI, NO, NZ, OM, PG, PH, PL, PT, RO, RU, SC, SD, SE, SG, SK, SL, SM, SY, TJ, TM, TN, TR, TT, TZ, UA, UG, US, UZ, VC, VN, YU, ZA, ZM, ZW.
- (84) Designated States (unless otherwise indicated, for every kind of regional protection available): ARIPO (BW, GH, GM, KE, LS, MW, MZ, NA, SD, SL, SZ, TZ, UG, ZM, ZW), Eurasian (AM, AZ, BY, KG, KZ, MD, RU, TJ, TM), European (AT, BE, BG, CH, CY, CZ, DE, DK, EE, ES, FI, FR, GB, GR, HU, IE, IS, IT, LT, LU, MC, NL, PL, PT, RO, SE, SI, SK, TR), OAPI (BF, BJ, CF, CG, CI, CM, GA, GN, GQ, GW, ML, MR, NE, SN, TD, TG).
- Published:**
— without international search report and to be republished upon receipt of that report
- For two-letter codes and other abbreviations, refer to the "Guidance Notes on Codes and Abbreviations" appearing at the beginning of each regular issue of the PCT Gazette.*



WO 2005/084136 A2

(54) Title: IMMOBILIZING AND SUPPORTING INFLATABLE SPLINT APPARATUS

(57) Abstract: Disclosed is a medical device that operates as a supporting splint for the limbs and other body parts necessary for the treatment of a variety of medical and surgical conditions. Said device is an inflatable, flexible, lightweight water-resistant splint whose measure of rigidity is easily controlled by the fitter or user. According to the present invention there are several embodiments of the splint, each suited to fit a different body part such as the limbs, torso, chest, pelvis, and neck. Said device, which is constructed of inflatable tubes, is made of two nylon layers welded together and coated with polyurethane. The tubes may be inflated by any means of supplying air pressure. The present invention is especially designed to allow normal blood circulation to the treated body part, provide ventilation to the area, enable easy inspection of an injury, and allow partial movement of the treated part.

IMMOBILIZING AND SUPPORTING INFLATABLE SPLINT APPARATUS

FIELD OF THE INVENTION

The present invention relates to the field of medical devices, and, more particularly, it relates to inflatable, versatile/universal/multi purpose splints.

BACKGROUND OF THE INVENTION

The traditional techniques of providing external support and immobilization in orthopedic conditions revolves around three existing types of devices: casts, which have application primarily in broken limbs; splints, which are used to immobilize and stabilize the limbs and the torso; and pressure bandages, which help control swelling and give a degree of support.

Creative individuals have come up with a variety of departures from these standard themes in order to achieve better patient treatment and recovery. Inflatable pouches made from various materials exist, adapted to be filled with either liquid or gas, and incorporating means for securing these pouches to and tightening them around the injured part of a human body. Splints of this kind effect the immobilization and compression of a limb or other part of a human body.

One of the alternative devices is presented in U.S. Pat. No. 5,954,676. This device utilizes two sets of multi-layer deformable materials, such as fiberglass shims located in pouches in first and second members having re-sealable bladders or sheaths that provide structural support on each side of the limb.

The main drawback of the device, which limits its application considerably, relates to its fixed and inflexible shape that does not take into consideration the three-dimensional form of the limbs, joints and torso, for instance.

A different device is U.S. Pat. No. 5,288,286, which is an adjustable pressure cast for orthopedic injuries. It is composed of three sets of air chambers and is only designed for treating orthopedic leg injuries such as fractures. As in the previous patent, this device suffers from an inconvenient structure, which may only support the calf, the ankle, and the foot of a patient without conforming to the shape of these structures.

U.S. Pat. No. 6,719,711 describes a third type of device, an inflatable splint with a series of modular sections that independently wrap around an injured body part, each section forming a circular structure that surrounds the injured limb. The device requires multiple sections when encircling the joints or various bends of the injured limb, as it is not designed to accommodate the three-dimensional shape of the human body. Furthermore, the circular shape of the fastened splint leaves no openings for inspection of the injured area.

There is a need for a method and a concept for a lightweight and convenient splint which adjusts to the shape of the limb, joint, or other body part, and which may also provide steady support to the trunk (i.e. spine, ribs, neck etc.), while at the same time allowing free blood circulation and ventilation, and enabling medical inspection of the injured area.

Such a device should further allow for as much functionality as possible and allow rigidity and flexibility to be adjusted as needed.

SUMMARY OF THE INVENTION

In accordance with the shortcomings of previous art, it is a principal object of the present invention to provide a splint device which will present a maximum adjustment range, so it can be easily and securely fitted to the injured body part, without bringing about any uncomfortable chafing and minimizing overall discomfort, that will also allow for adequate blood circulation to the injured part, and will support

the joints, limbs and any other body parts in an optimal position with a controllable measure of rigidity.

The present invention is aimed, in particular, at all those conditions in which absolutely rigid support is not needed.

It is yet another object of the present invention to introduce a multi purpose splint device that will be appropriate for the treatment of a wide range of conditions such as fractures, sprains, and post-operative support, that will prevent bedsores, and that will allow for the inspection of various wounds. The present invention provides a handy solution for the temporary support of an injured limb in field conditions and while transporting a patient, and can also be used as a long-term cast or bandage during the full course of treatment, including postoperative support.

The said splint offers solutions for the setting and treatment of various areas of the body, such as the neck, limbs, pelvis, spine, and chest areas. This novel splint answers the basic need for a simple device that is easy to use, handle, store, and transport.

It is yet another object of the present invention to offer a practical solution to the needs of various medical teams such as hospital staffs, EMS personnel, health care providers for the elderly, and army and police emergency teams, as well as for use in private homes.

The invention describes a splint designed to allow for an adjustable and comfortable fit to different parts of the body, which achieves maximum comfort and facilitates the recuperation period. It is a simply structured splint, which allows for uncomplicated assembly and operation. The splint is designed to fit the shape of the body part in need of treatment. It provides support and wrapping for the injured area from three sides. The splint is made out of inflatable ribs. Using a hand pump or an air pressure source tank, the ribs may be inflated to various degrees that provide the optimum support and comfort required for the particular conditions. Ventilation holes in the structure allow for sufficient airing and circulation of the treated area. The splints are secured into place by Velcro straps.

It is a further object of the present invention to allow the user movement and function of the joint and limb or body part, even at the site of the injury, to such a degree as is ordered by the treating physician. This concept being in line with contemporary knowledge on the healing of soft tissue wounds and bones. The quality of healing is enhanced in certain phases of repair and healing when controlled mechanical forces create a load on the healing tissues and enable movement of the injured area .

The simplicity of the design in one single unit, and assembly enables the medical or paramedical fitter or the patient himself to apply, use, assemble, and adjust the splint with minimal or no assistance.

The invention is the combination of inflated tubes with flexible material between the tubes, so designed in specific shapes for various bodies parts as to fit to the anatomical shape of the specific part when wrapped around the part and held together by means of Velcro straps.

BRIEF DESCRIPTION OF THE DRAWINGS

These and further features and advantages of the invention will more clearly understood in the light of the ensuing description of a preferred embodiment thereof, given by way of example only, with reference to the accompanying drawings, wherein-

Figure 1 is a perspective view of a first embodiment of the invention in an unassembled and un-inflated condition.

Figure 2 illustrates the first embodiment of the invention assembled on a leg.

Figure 2a illustrates a further example of the first embodiment, assembled on the whole length of a leg.

Figure 2b illustrates one example of an optional outrigger that prevents rotation of the limb and the splint.

Figure 2c illustrates another optional outrigger that folds in the middle to allow projection to one side only.

Figure 3 illustrates a cross section of the splint as assembled on a leg.

Figure 4 illustrates perspective view of a second embodiment of the invention in an unassembled and un-inflated condition.

Figure 5 illustrates a cross sectional view (section A) of the second embodiment as illustrated in figure 4.

Figure 6 illustrates the second embodiment of the invention assembled on an arm.

Figure 7 illustrates a cross sectional view (section B) of the second embodiment as illustrated in figure 6.

Figure 8 illustrates another example of the present invention in the form of a vest for the treatment of fractures of the ribs.

Figure 8a is a side view of the same example of a vest for the treatment of fractures of the ribs.

Figure 9 illustrates an example of the present invention used for shoulder, arm, and elbow support.

Figure 9a is the same example seen from the side.

Figure 10 illustrates an example of the present invention in the form of a corset for compressing the pelvis in cases of pelvic ring fractures.

Figure 10a shows a cross section of the above example.

Figure 10b is a perspective view of the pelvic corset in an unassembled condition

Figure 11 is a further example of the present invention, for the wrist.

Figure 12 illustrates an example of the present invention for supporting the neck.

Figure 12a is a side view of the same example for supporting the neck.

Figure 12b is the rear view of the same example for supporting the neck.

DETAILED DESCRIPTION OF THE INVENTION

The present invention is a new and simple medical device, aimed to help treat variety of general medical and surgical conditions, including orthopedic, rheumatic, and rehabilitative conditions, by supporting, splinting, and partially immobilizing the injured body part in a desired position. It is a comfortable-to-wear, lightweight device, which is simple and easy to assemble, water-resistant, and demands very little storage space. When deflated, the splint folds into a compact, flat package. This multipurpose device facilitates emergency and long-term treatments of different sorts of conditions, including support for injuries, dislocations, fractures, post operative conditions, and variety of diseases of the skeletal and local motor system

The preferred embodiments of the invention are inflatable and adjustable, suited to fit different body parts including the limbs, chest, torso, spine, pelvis, and neck. The measure of air pressure inflating the device and the manner of fastening it around a body part are controllable and may be adjusted to suit the specific needs of any given condition. The device is made from a double layer of nylon coated by polyurethane, a flexible and lightweight material that is also strong and waterproof.

According to known in the art research, it is advisable to enable the injured person some mobility and functionality within the splint as it contributes to the healing process. The present invention provides the patient with a supporting splint that is flexible enough to allow movement of nearby joints and even the injured site itself.

Figure 1 offers a general description of the first embodiment of the invention, suited for foot & ankle injuries, in an unassembled condition. The splint 10 is

comprised of a main body 20 and two or more unattached adjustable straps: a front upper strap 6 and a front lower strap 7. When in use, parts 24, 25, 26a, and 26b wrap the leg from three sides: part 24 encompasses the left side of the leg and part 25 the right side, while the back of the leg is wrapped by splint central part 26a and 26b. Connecting Velcro surfaces 30 and 6 fasten the device around the calf, leaving the anterior surface uncovered and visible in its whole length.

The lower right part 40a and left part 40b of the splint wraps around the foot, while part 41 covers the sole of the foot. Attaching Velcro straps 31 to strap 7 on top of the foot and strap 42a to 42b at the sole fastens the lower part of the splint for supporting the lower part of the foot. Figure 2 illustrates the device as it is assembled on a leg 59.

Both the lower and the upper part of the splint have ventilating holes 52 to increase the comfort during long term use of the device, and at the edge of parts 40a and 40b there are loops 50 which, if necessary, allow for suspending the leg raised up on a hook 55 to prevent it from swelling, as illustrated in figure 2.

Parts 24, 25, 26, 40, and 41 contain inflatable tubes. These tubes are designed to wrap the leg, the foot, the ankle, and the heel of the injured person, taking into account the leg's anatomical shape and structure for maximum compatibility. The tubes in the splint may be inflated using a hand pump 16 or other type of pump, which is connected to the said tubes through pipe 5 and valve 17. Alternatively, an air pressure source can be connected to valve 17 and used for the same purpose. Once inflated, a valve 15 may be used to open the airways and let the air out of the tubes. Combining the effect of hand pump 16 and valve 15 allows for achieving the desired pressure in the tubes resulting, in the required stiffness of splint 10 around the leg, so that the needed support is maintained and the movement and flexibility of the leg is controlled without causing unnecessary discomfort. The pressure that the air tubes create on the leg does not obstruct blood flow to the leg, and ventilation holes 52 allow for sufficient airing of the area. When inflated, the splint takes up the shape of the part of the body for which it was designed, as figure 3 illustrates. An optional monitor for measuring the pressure in the splint may be added to the splint.

Control over the amount of pressure and the tightness of the splint on the leg is mainly achieved by tightening or loosening Velcro straps 6 and 7 to splint Velcro 30 and 31 respectively. In a different embodiment, Velcro straps 6 and 7 are stitched to one of the sides of the splint body 20. As illustrated in figure 2, the patient can easily reach said straps, which are located on the front side of the leg, and the patient has convenient access to the pump in order to adjust the level and volume of splint air pressure with minimal or no assistance, to achieve optimal results.

Figure 2a shows a further example of the first embodiment of the invention, which is a splint for the whole length of the leg up to below the groin 106, with Velcro straps below the knee 107 and above the knee 108. The insert shows that the position of the straps can be adjusted at will by sliding the straps along the tape at the back of the splint 109, or the straps can be fixed to the body of the splint as in Figures 1 and 2, or the straps can be free and separate from the splint. Figure 2a also illustrates the uncovered part of the leg along its entire anterior surface which is an important principle of the invention when applied to a limb, ensuring that the limb is never entirely encased in a circular element which prevents inspection and creates the danger of embarrassing the blood circulation

Figures 2b and 2c are optional outriggers for providing additional support to the foot. Figure 2b shows an outrigger 100 that can be attached to the foot section of the splint 101 for the purpose of preventing rotation of both the limb and splint 102, 103, and 104. Attachment is by Velcro strips at the points of meeting with the splint under the heel and below the suspension ears. Suspension, when desired, is by the reinforced perforations 105. Figure 2c shows an outrigger 100 that folds in the middle 110, as seen in the insert, to allow projection to one side only. This embodiment is intended as a universal first aid splint and for suitable conditions requiring support for the leg from the toes to above the knee. The inner surface of the splint is so shaped as to avoid pressure on the heel and malleoli. An outrigger can be used also in different embodiments of the invention for correcting deformities and preventing pressure sores, particularly for the neck femur bone.

Figure 3 illustrates a cross section of the splint as it is assembled on a leg 59. In this illustration, it is easy to see that the splint is designed to adjust to and fit the

structure of the body part (the leg 59, in this example) and its joints, one limb surface remaining free with only the Velcro straps traversing that surface.

The second embodiment of the invention is illustrated in figures 4, 5, 6, and 7 and is designed to be assembled on an arm. The principles guiding the structure of this embodiment are similar to those of the first embodiment; it differs from the first only in that the second embodiment is intended to fit the structure and the treatment of a human arm.

Figure 4 illustrates the second embodiment in an unassembled state. The main body of the splint is divided into two main parts: for supporting the upper part of the arm 61a between the shoulder and the elbow, and the lower part of the arm 61b between the elbow and the wrists. Enclosing the main body 61 are Velcro straps 62 and 63 that connect to each other when the device is assembled on an arm. The main part 61a contains an aperture for the shoulder 67 and the main part 61b includes an aperture for the palm 66 and a supporting surface for the palm 66 and hand 65.

Like the main body of the first embodiment, these two sections are both comprised of inflatable tubes which, when assembled on the arm, are designed to support the arm from three directions. Figure 5 displays a cross-section of the splint when it is inflated and unassembled. This figure clearly shows the four tubes a, b, c, and d in the splint. Velcro straps 62 and 63 connect when the splint is assembled.

Also seen in figure 4 are the ventilating holes 68, similar to the ones on the first embodiment of this invention 52, and a support strap clip 64. This clip enables the attachment of straps that transfer the weight of the hand to the shoulders or to the waist. Figure 6 illustrates the splint assembled on an arm. The figure displays the two options of attaching the supporting straps: a suspension strap 70 around the patient's neck and a strap wrapped around the waist 71. The straps hook to the splint via said clip 64.

Figure 6 also clearly illustrates the function of the aperture of the shoulder 67, the palm's aperture 66, and the supporting surface for the palm 65. The structure of this embodiment of the splint is suited to hold the arm in a comfortable 90-degree

angle at the elbow. Figure 7 illustrates a cross section of the assembled splint. This figure shows that the splint can provide support to the arm from up to four directions.

Another embodiment of the present invention, shown in figures 8 and 8a, is a vest splint 150, designed for the treatment of fractures of the ribs or to support the rib cage or both. The inflated tubes are arranged in segments 152 that can be inflated separately in order to exert selected pressure on different areas of the chest wall according to necessity. The inflatable rib-tubes of the splint are aligned to follow the inclination of the rib bones. The vest is wrapped around the chest, leaving two apertures for the arms and is fastened in the front by Velcro straps 153.

For further clarification of the use and versatility of the present invention, Figures 9 through 12a provide additional examples of the various configurations that are possible with the present invention.

Figure 9 shows the present invention configured to provide shoulder support 111, arm support 112, and elbow support 113, together with a classic neck suspension 114, cross shoulder straps 115, and body straps 116. An optional inflated cushion 117 between the chest wall and the arm prevents pressure and ventilates the armpit. Velcro straps 118 attach the splint from the front of the arm and forearm. Figure 9a shows the same shoulder support seen from the side. The inflated tubes 119 and 120 can be variously arranged in any direction- longitudinal 119 or transverse 120 - in order to create a well-shaped housing fitted to the body part when attached with the Velcro straps 118 that close around the front of the arm and forearm.

Figure 10 shows an example of a corset arrangement for compressing the pelvis in cases of pelvic ring fractures. The uninflated corset is tightly wrapped round the pelvis and Velcro straps 122 are firmly secured over an inflatable abdominal pillow 123. Inflating the corset through valve 124 exerts circular pressure to stabilize the pelvis and inflating the abdominal pillow 123 through valve 125 pressurizes the abdominal cavity to aid the cessation of bleeding. Figure 10a is a cross-section of figure 10 at A-A to show the wrap of the inflated tubes 126 around the pelvis and the pressure of the pillow 123 on the abdominal cavity 127, which can be adjusted by the tightness of the Velcro straps 122 and the degree of inflation of the tubes of the corset. Figure 10b describes the pelvic corset, showing the longitudinal tubes 126 interspaced

with tubeless material 129 to allow the wrap around the pelvis and the arrangement of straps 122 with their Velcro attachment areas 130.

Figure 11 is a splint organized for the wrist with inflated tubes on the forearm 131 and on the back of the hand 132, which allows movement at the wrist. Attachment is by Velcro bands across the palm 133 and around the forearm 134. The front of the palm, wrist, and forearm are visible for inspection. A narrow sleeve, which has a hand section 135 and a forearm section 136, is for the insertion of rod extensions of a universal joint should it be desired to position the wrist in any special configuration.

Figures 12, 12a, and 12b show the front, side and back of a model of the present invention for supporting the neck. The inflatable tubes 140 are interspersed with non-tubed areas 141 to allow for wrapping the splint around the neck. Fastening is at the front or side with Velcro. An aperture 142 allows access to the trachea.

These unique designs for the splints, as described, allow for setting and stabilizing the injured body part while providing a controlled range of flexibility, ensuring the necessary support of the injured area, and improving the course of treatment for better results.

While the above description contains many specificities, these should not be construed as limitations on the scope of the invention, but rather as exemplifications of the preferred embodiments. Those skilled in the art will envision other possible variations that are within its scope. Accordingly, the scope of the invention should be determined not by the embodiment illustrated, but by the appended claims and their legal equivalents.

What is claimed is:

1. A splint for immobilizing and supporting a limb or other body parts of a human, wherein said splint is made of flexible material for covering body parts and articulations from at least three sides and where said splint includes:

- a. inflatable tubes interconnected by non-inflatable parts for achieving variable degrees of support, stiffness and restriction of movement;
- b. ventilation holes for skin ventilation, contained in the non-inflatable parts;
- c. at least one gas pressure source device connected to said splint;
- d. at least one adjustable strap for connecting splint edges;

wherein the inflated structure of the splint fits the structure and anatomical shape of the appropriate body part for the purpose of stabilizing and providing support to the patient's body part and its articulations in varying degrees of rigidity and in particular positions.

2. The splint of claim 1 for supporting limbs wherein a part of the limb remains uncovered.
3. The splint according to claim 1, wherein the adjustable straps are made of Velcro.
4. The splint according to claim 1, wherein said splint is designed to wrap the torso, taking into account the structure of the body and its anatomical shape for maximum compatibility.
5. The splint according to claim 1, wherein said splint is designed to wrap to the neck, taking into account the neck's anatomical shape and structure for maximum compatibility.
6. The splint according to claim 2, wherein said splint is designed to wrap the leg, the foot, the ankle and the heel of the patient, taking into account the leg's anatomical shape and structure for maximum compatibility and preventing pressure on the heel.

7. The splint according to claim 2, wherein said splint is designed to wrap the leg, the foot, the ankle, heel, knee and thigh of the patient, taking into account the leg's anatomical shape and structure for maximum compatibility and preventing pressure on the heel.
8. The splint according to claim 2, wherein said splint is designed to wrap the arm, fit the shoulder structure, and support the palm, taking into account the arm's anatomical shape and structure for maximum compatibility and immobilizing the shoulder joints or upper and lower arm in any desired position.
9. The splint according to claim 1, wherein said splint is designed to wrap the rib cage, wherein the inflated tubes are arranged in segments that can be inflated separately in order to exert selected pressure on different areas of the chest wall according to necessity, taking into account the curves and structure of the ribs for maximum compatibility.
10. The splint according to claim 1, wherein said splint is made of two nylon layers joined together by soldering means.
11. The splint according to claim 1, wherein said splint is made of two nylon layers which are coated with polyurethane.
12. The splint according to claim 1, wherein movement, rigidity, and stabilization of said limb articulation are controlled by the degree of air pressure in said splint.
13. The splint according to claim 1, wherein the pressure source device is a mechanical pump.
14. The splint according to claim 1, wherein the pressure source device is an electrical pump.
15. The splint according to claim 1, wherein the pressure source device is a pressure canister.
16. The splint according to claim 1, wherein in the inflated state, the splint takes up the shape of the body part for which it was designed.
17. The splint according to claim 1, wherein the tightness of the splint on the body part is controlled by the fastening or loosening of straps.

18. The splint according to claim 1 further including a suspension strap.
19. The splint according to claim 1, wherein pressure within the splint is controlled by a valve.
20. The splint according to claim 1, wherein the adjustable strap is detachable.
21. The splint according to claim 1, wherein the degree of rigidity of the splint on the body part enables partial movement of the wrapped joints.
22. The splint according to claim 1 further comprising at least one loop connected to the edge of said splint for suspension purposes.

Figure 2

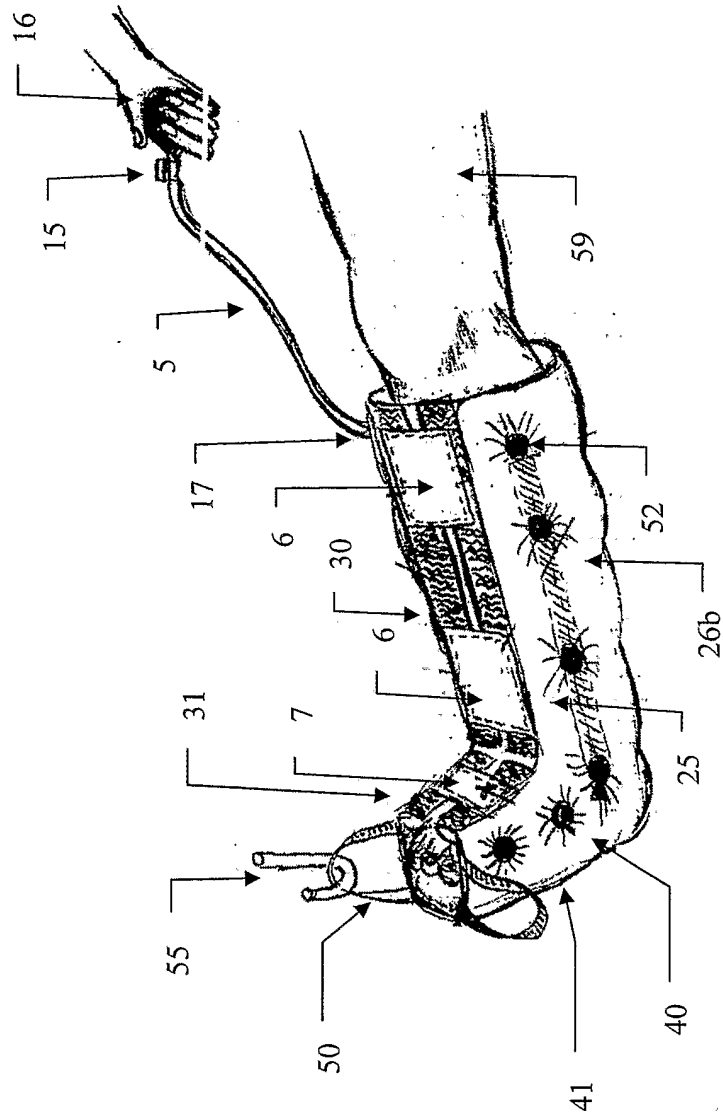

Figure 2A

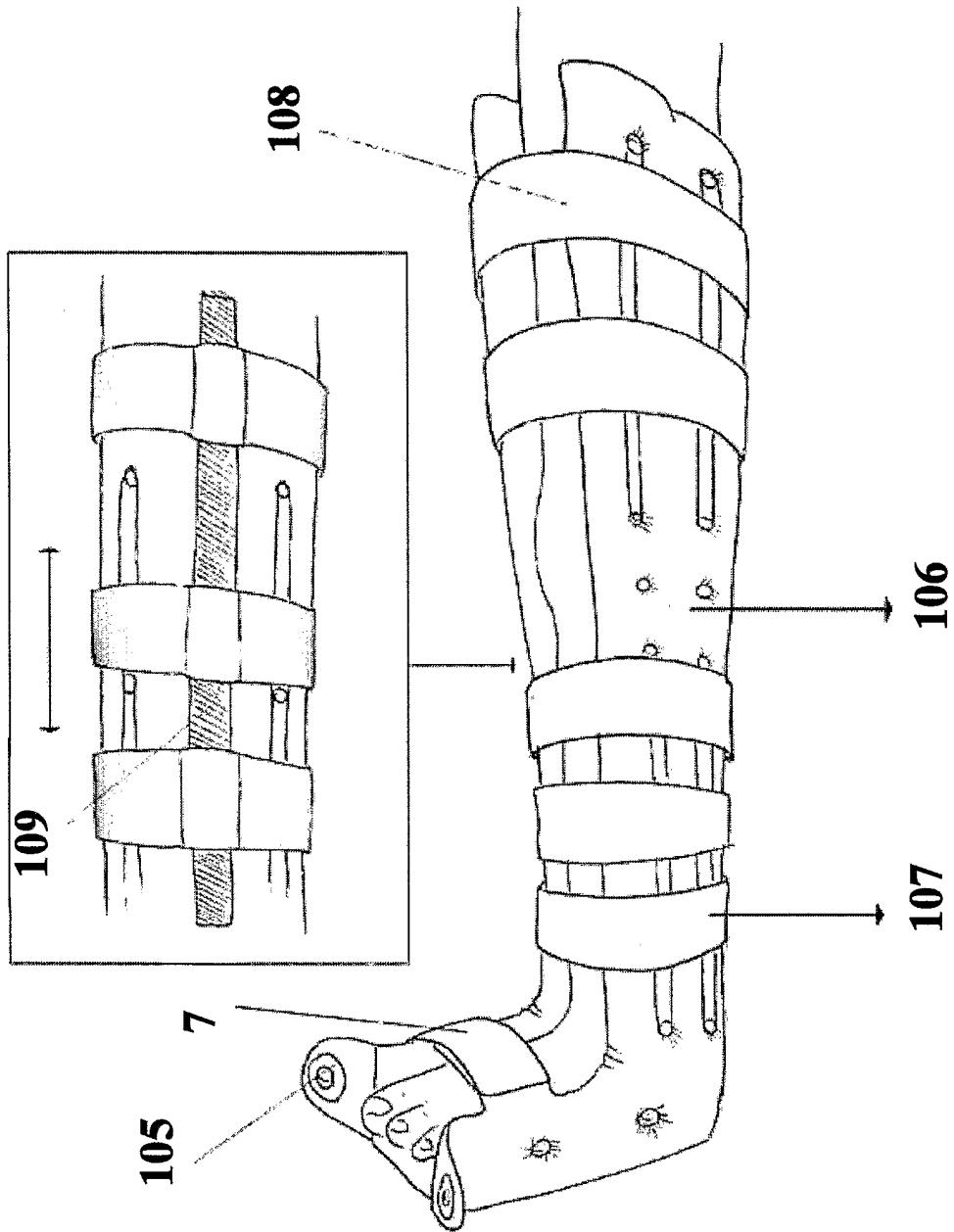

Figure 2B

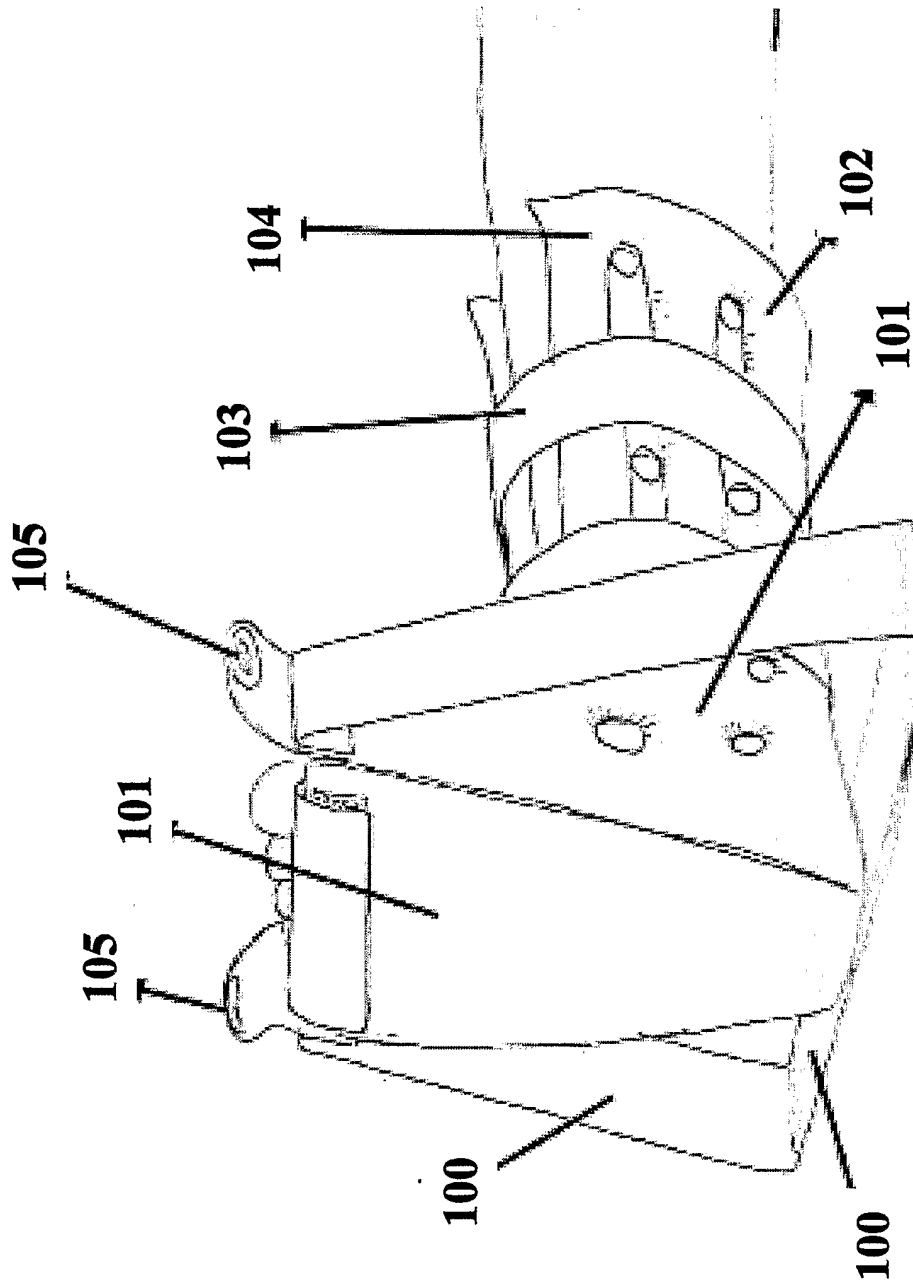

Figure 2C

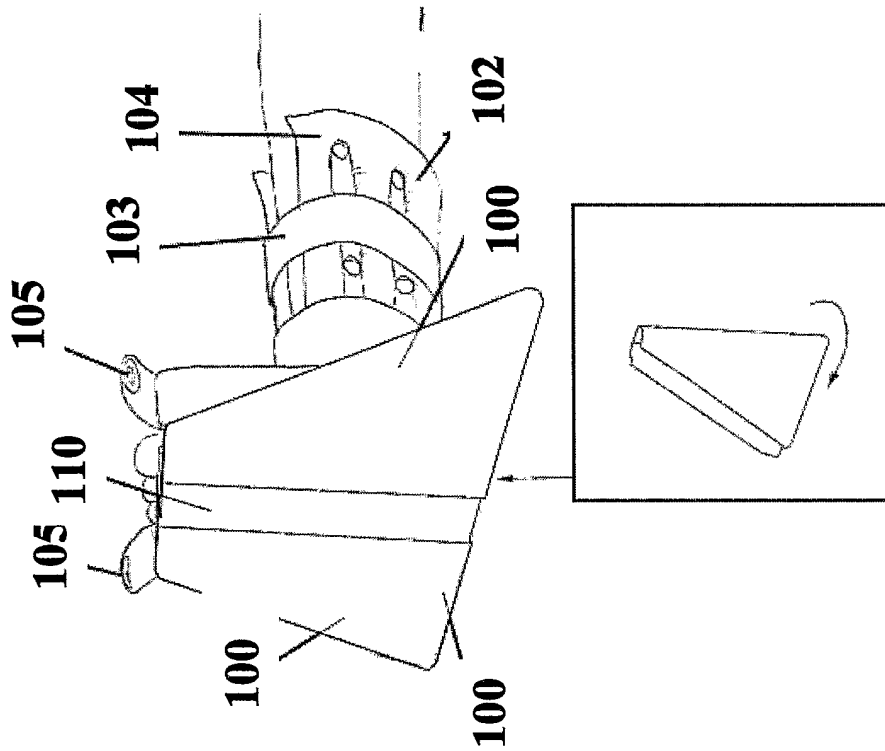

Figure 3

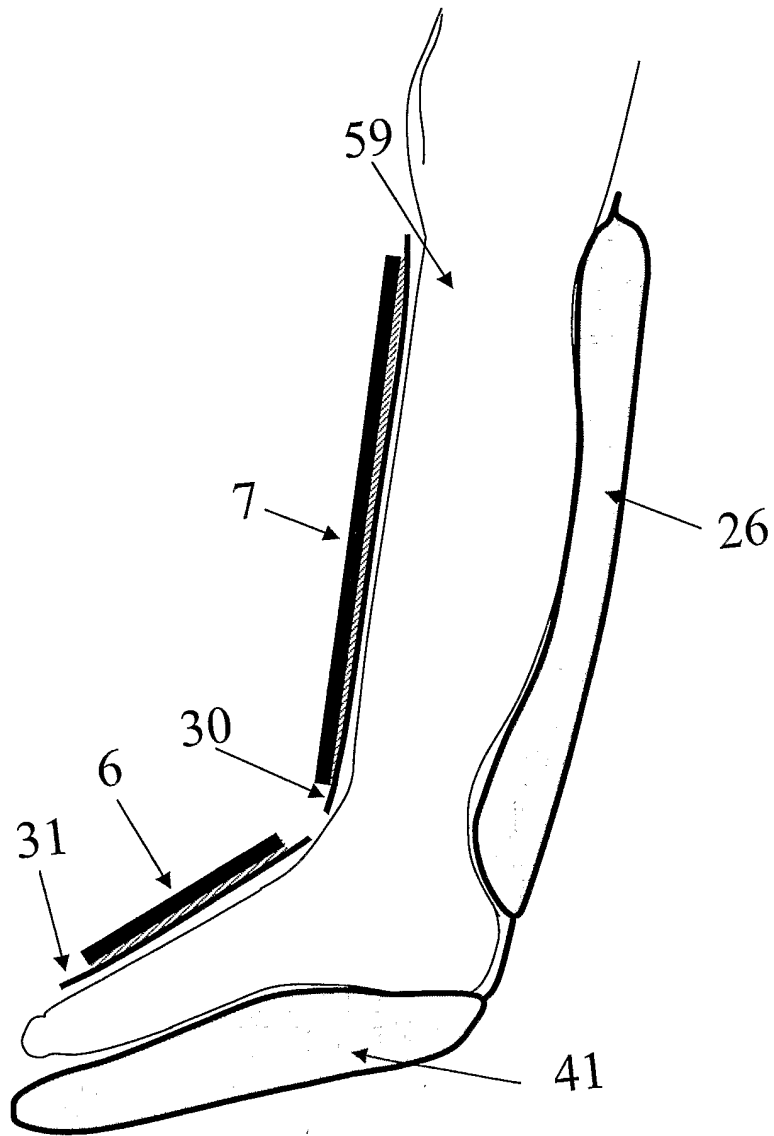

Figure 4

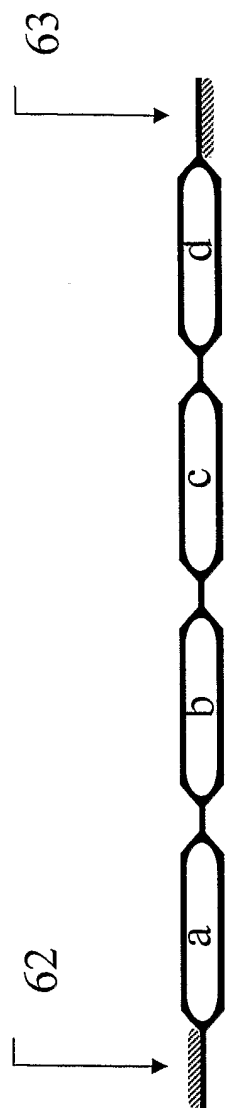

Figure 5

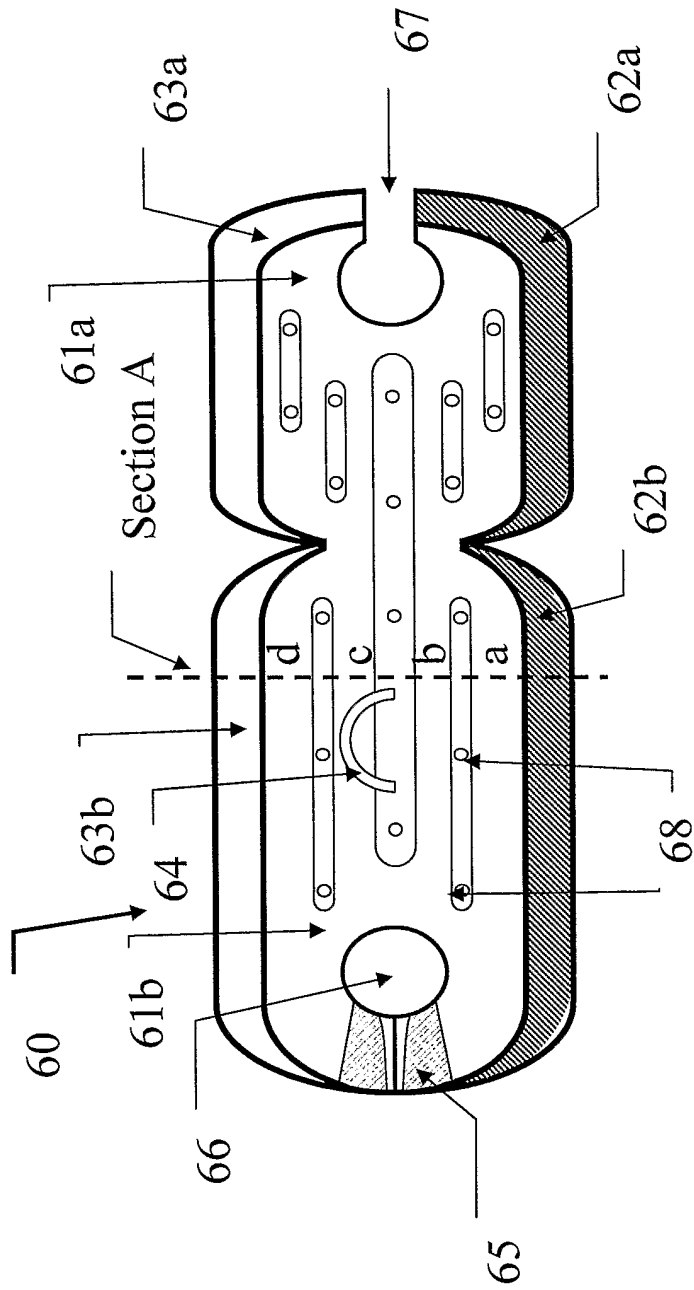

Figure 6

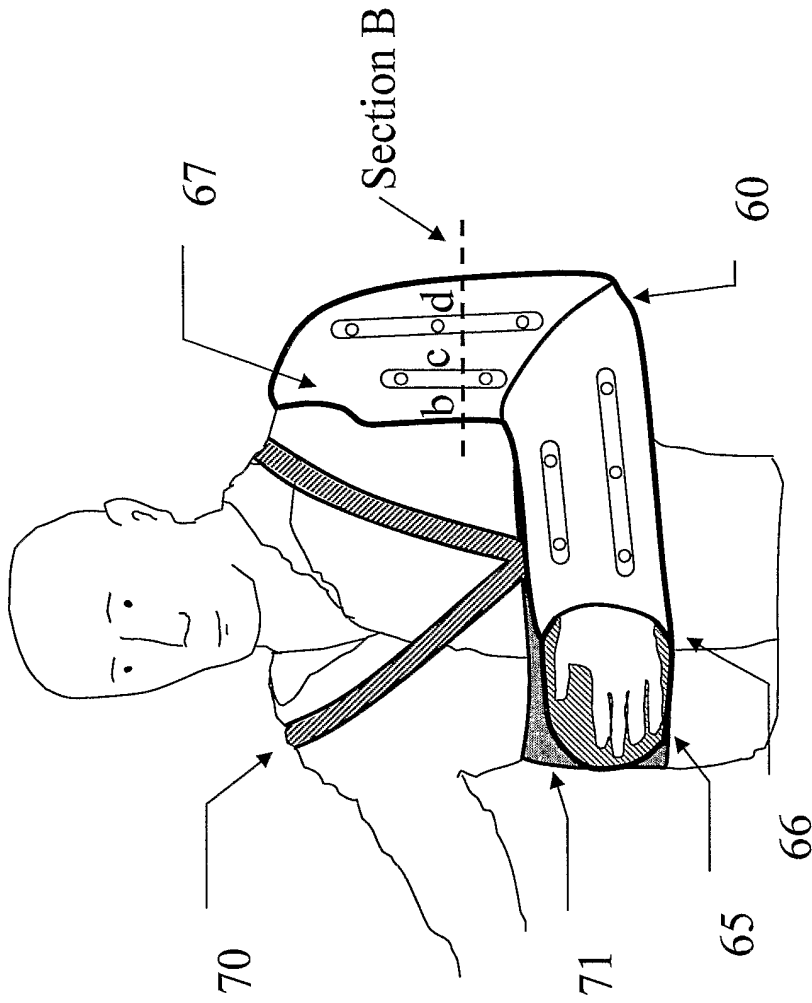

Figure 7

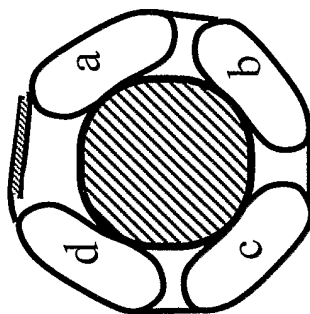

Figure 8

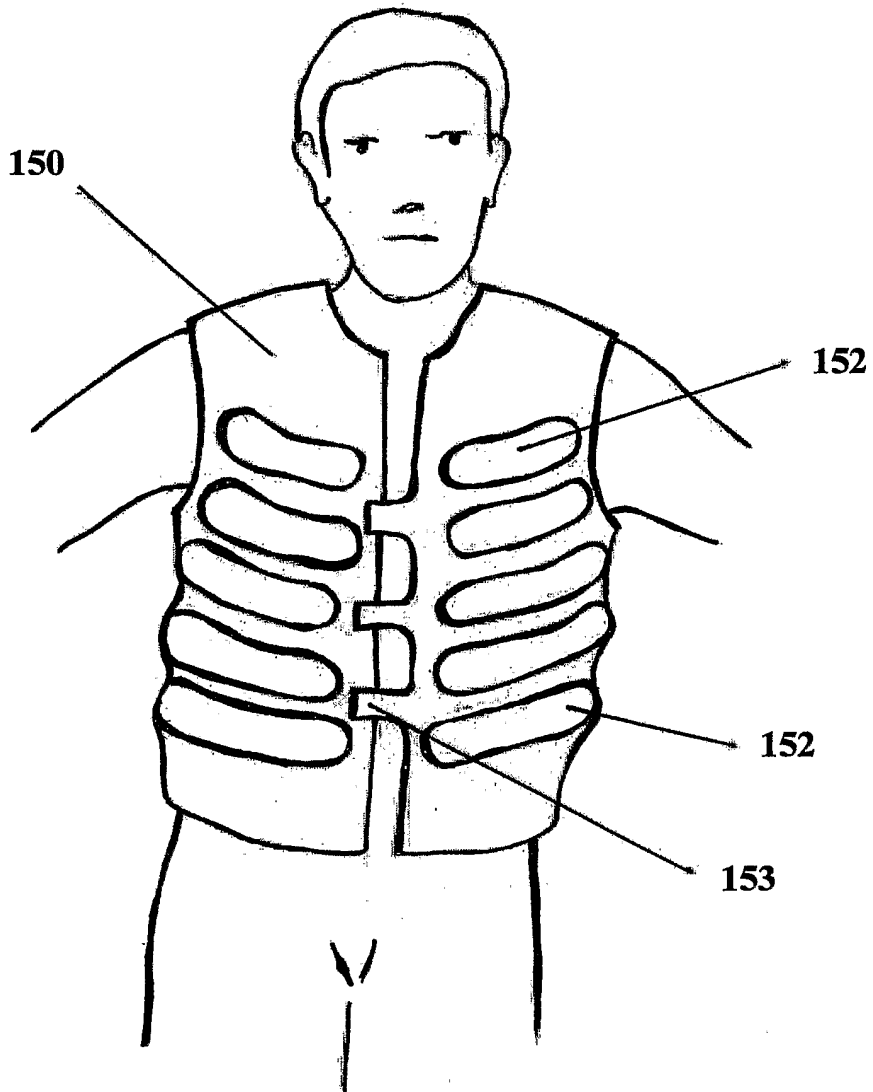
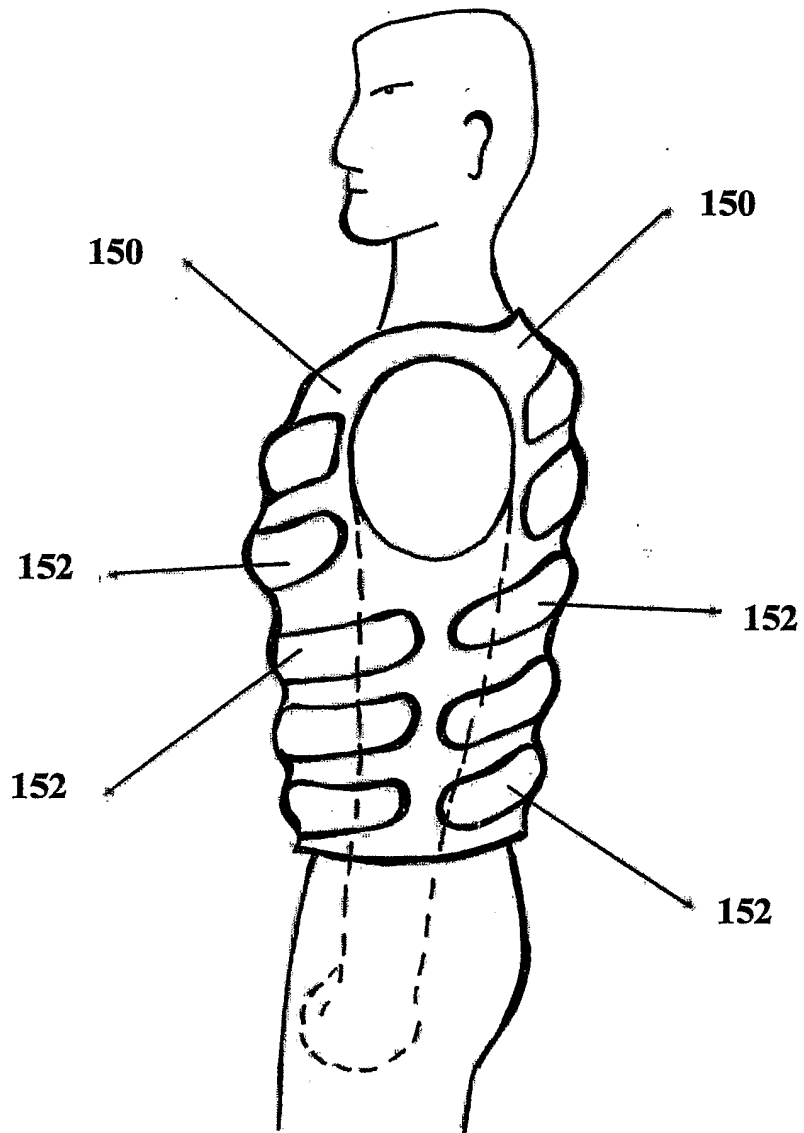

Figure 8A



12/21

Figure 9

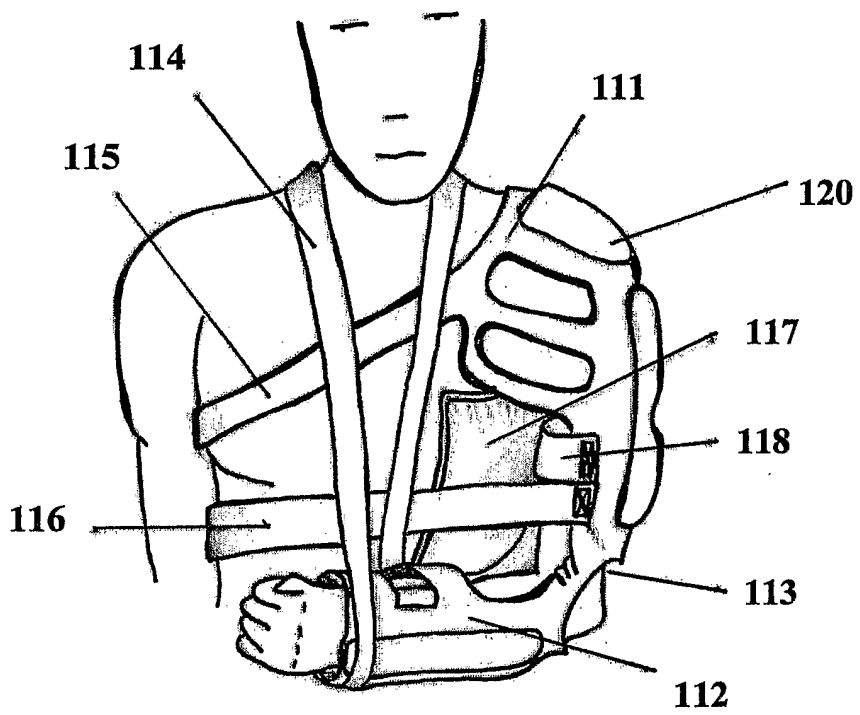

Figure 9A

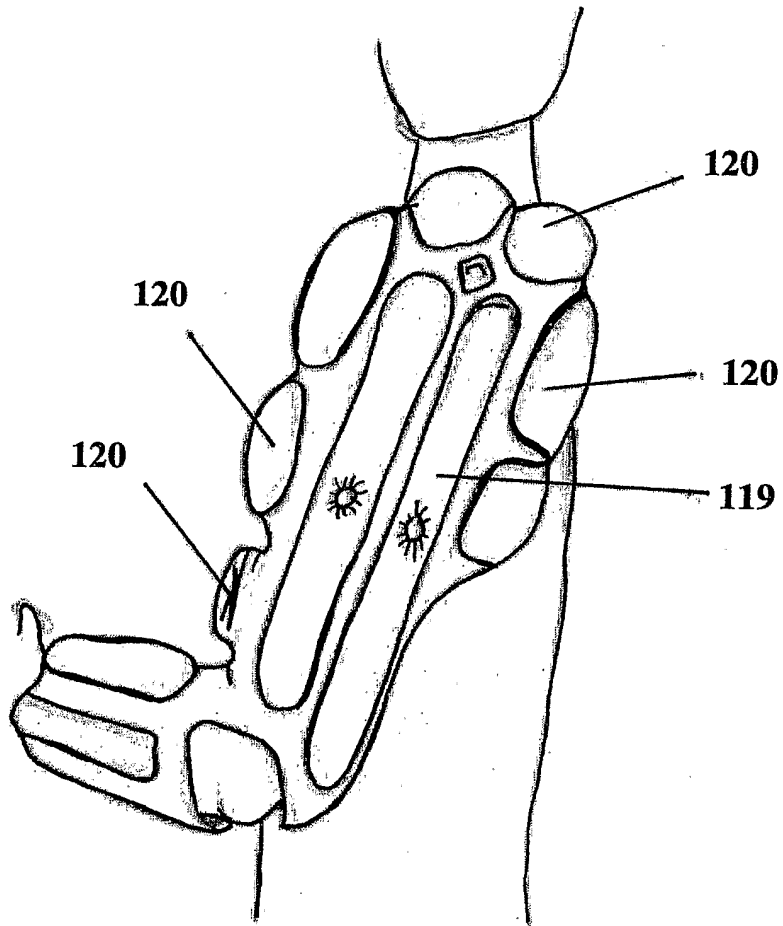
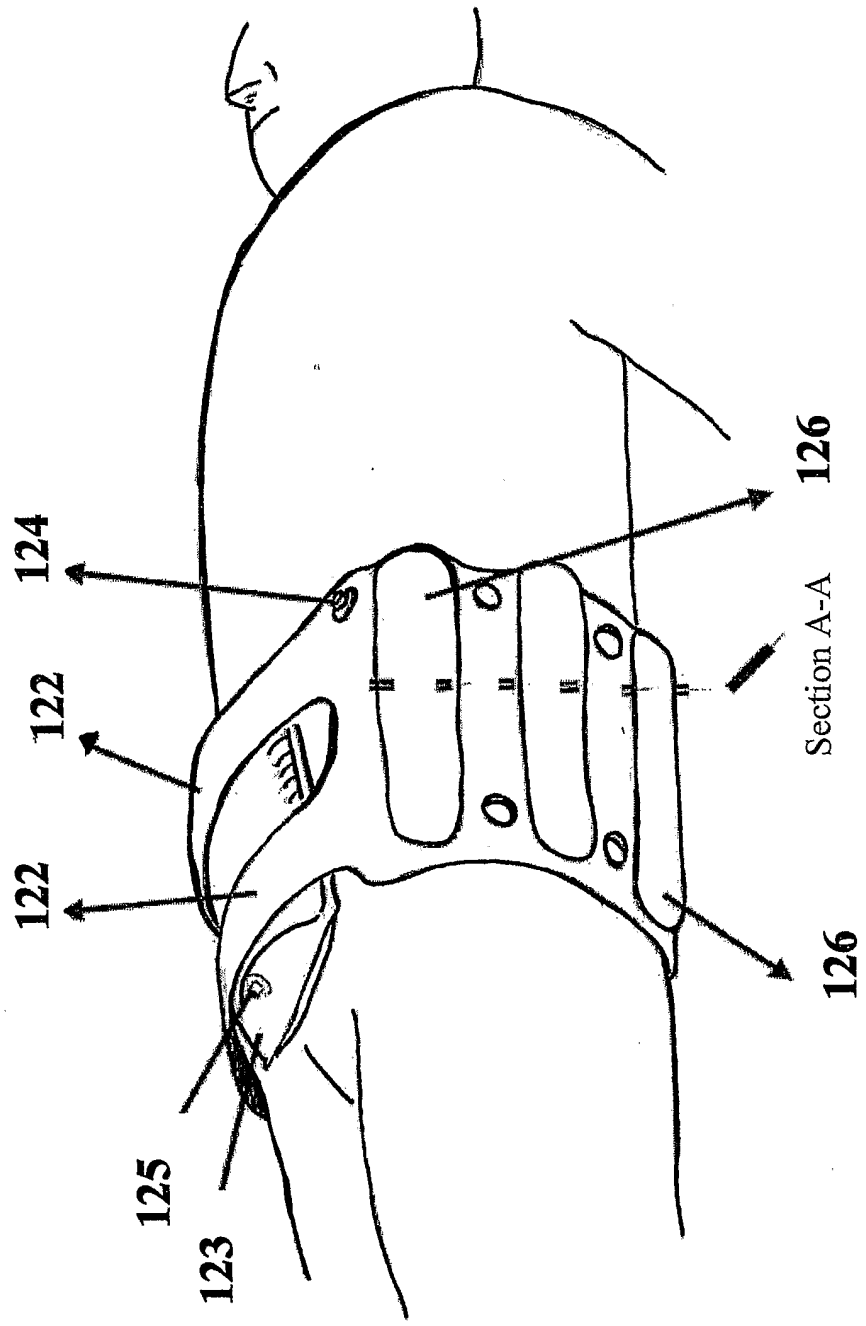

Figure 10



15/21

Figure 10A

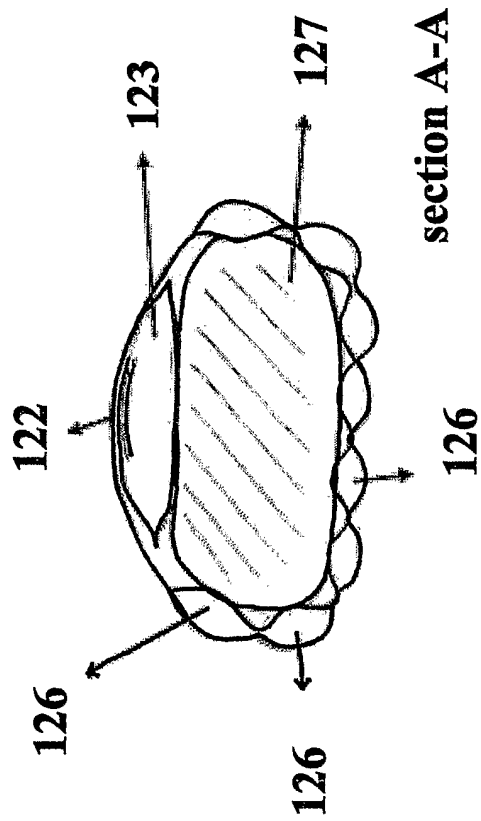
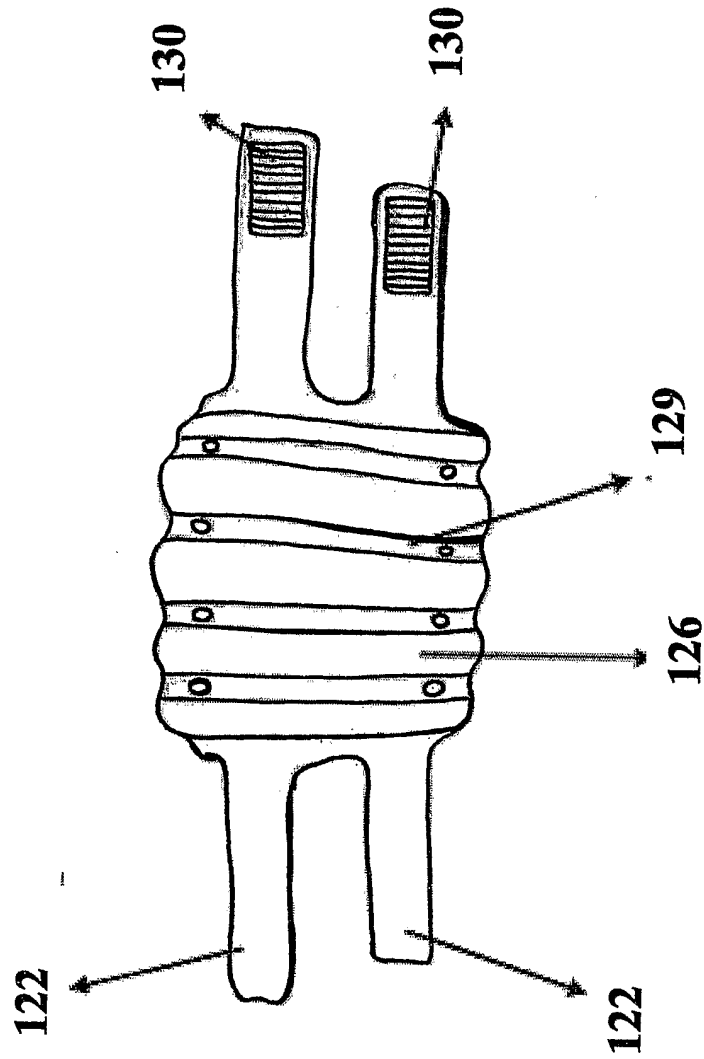

Figure 10B



17/21

Figure 11

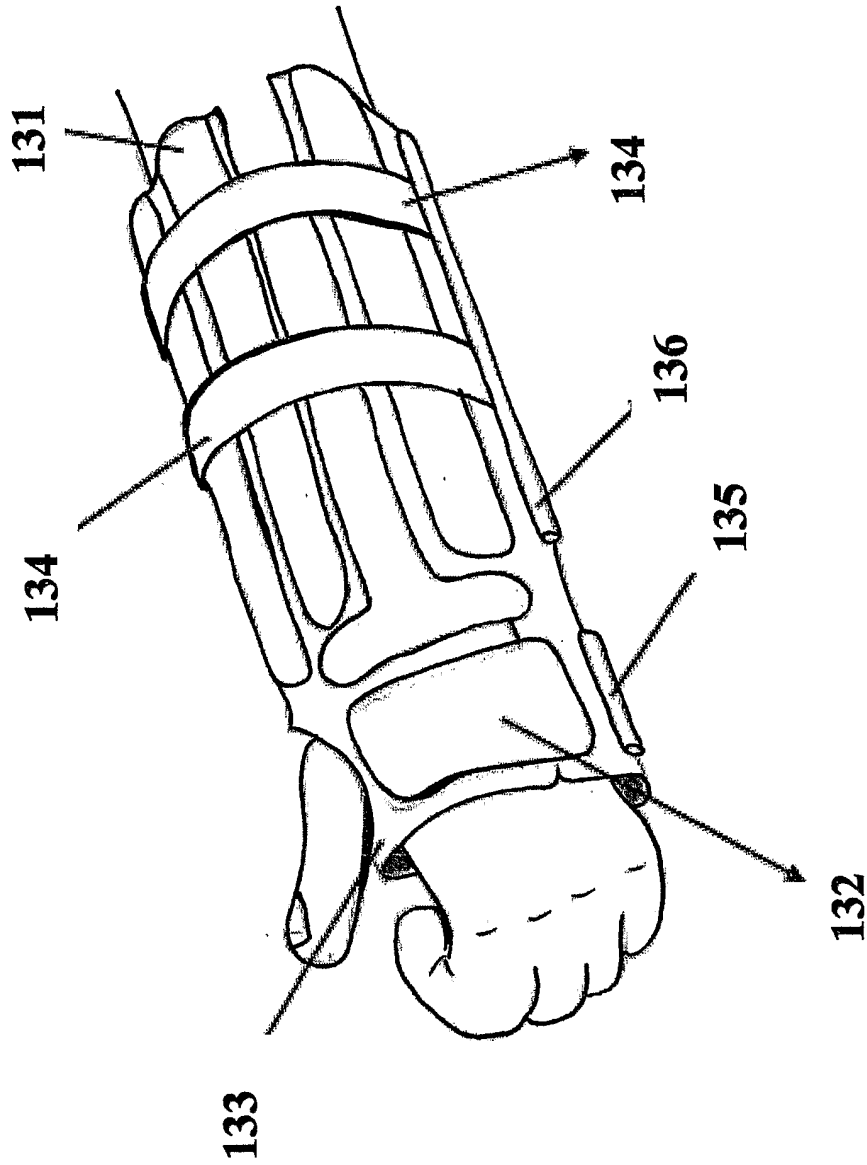

Figure 12

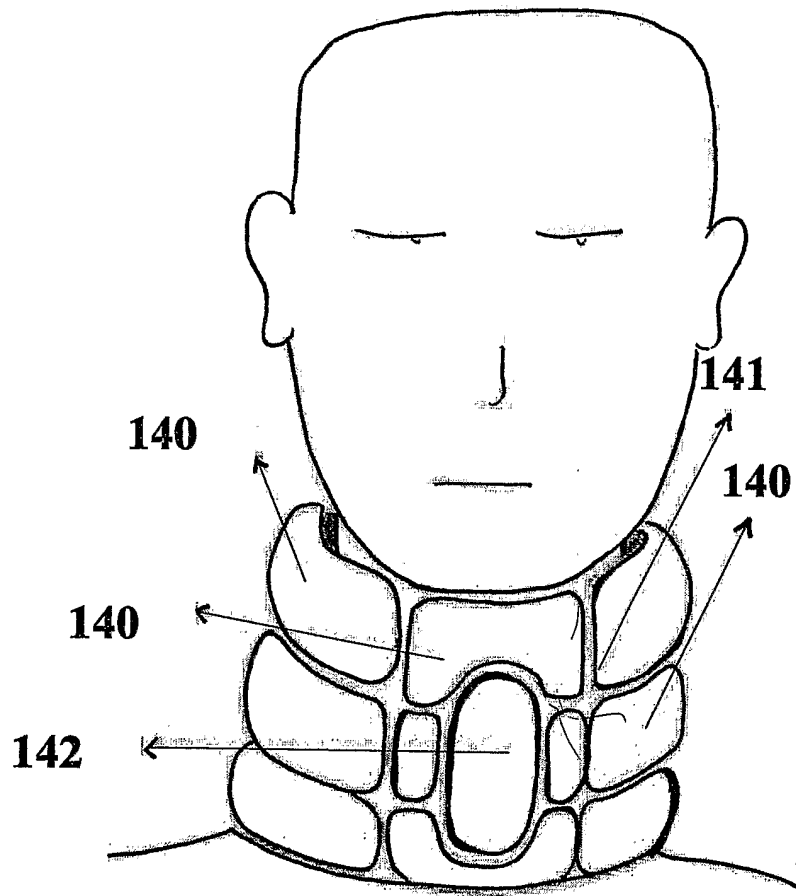

Figure 12A

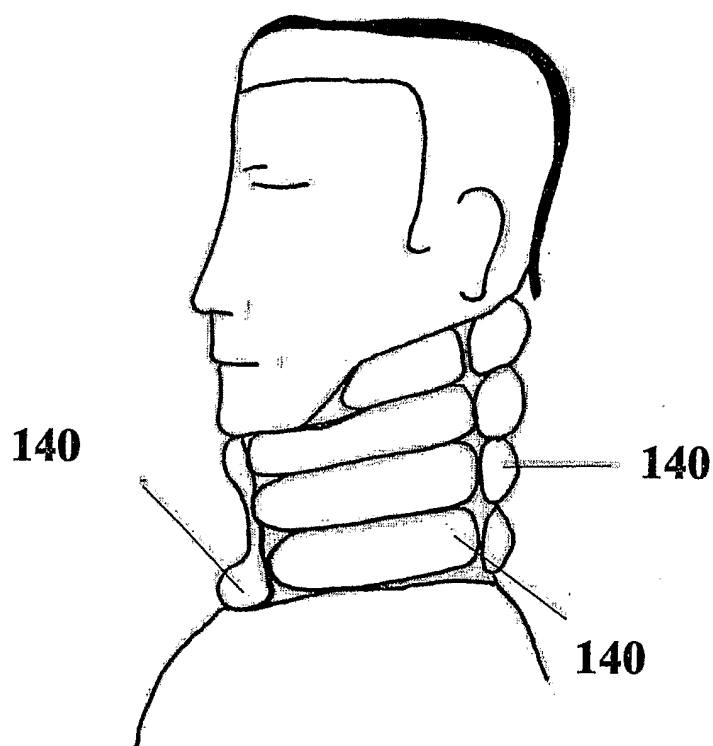

Figure 12B

