



US007837936B1

(12) **United States Patent
Martin**

(10) **Patent No.:** US 7,837,936 B1

(45) **Date of Patent:** Nov. 23, 2010

(54) **HAND-HELD FLUID ANALYZER**

2002/0110497 A1* 8/2002 Monblanc et al. 422/102

(75) Inventor: **Lawrence Martin**, St. Petersburg, FL (US)

* cited by examiner

(73) Assignee: **Akers Acquisition Sub, Inc.**, Thorofare, NJ (US)

Primary Examiner—Walter D Griffin

Assistant Examiner—Bobby Ramdhanie

(*) Notice: Subject to any disclaimer, the term of this patent is extended or adjusted under 35 U.S.C. 154(b) by 390 days.

(74) *Attorney, Agent, or Firm*—Thomas E. Toner; Smith & Hopen, P.A.

(21) Appl. No.: **11/874,677**

(57) **ABSTRACT**

(22) Filed: **Oct. 18, 2007**

Related U.S. Application Data

(62) Division of application No. 10/604,810, filed on Aug. 19, 2003, now Pat. No. 7,285,246.

A hand-held device detects the presence of a preselected substance in the breath. A deformable housing forms a test chamber for interacting an indicator reagent with the breath. The contents of the test chamber are exposed to the breath introduced into the chamber. The presence of a substance in the breath causes the indicator reagent to undergo a visually ascertainable change. The indicator reagent is secured within the test chamber between a pair of filter plugs having plural detents prevent slippage of the filters. Additional embodiments lower the user's risk of being cut by glass shards, prevent reagent inhalation, enhance the visual aspects of the device, and physically indicate the presence of breath flowing through the device.

(51) **Int. Cl.**
G01N 21/00 (2006.01)

(52) **U.S. Cl.** **422/56**

(58) **Field of Classification Search** 422/56
See application file for complete search history.

(56) **References Cited**

U.S. PATENT DOCUMENTS

4,740,475 A 4/1988 Paul

4 Claims, 12 Drawing Sheets

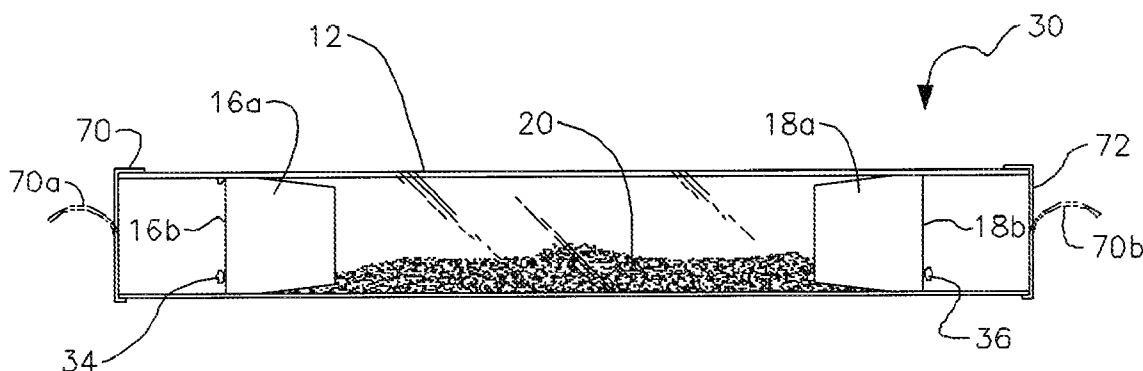

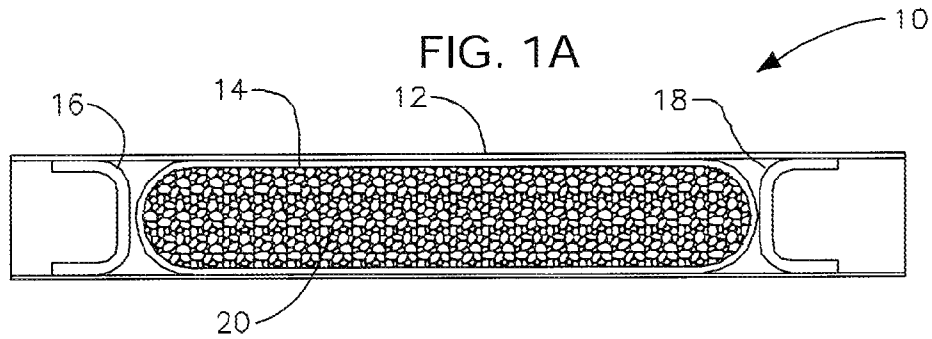

Prior Art

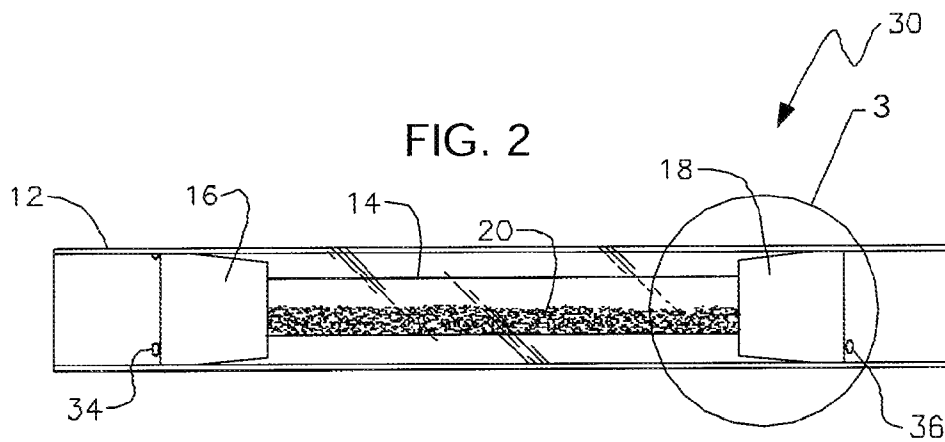
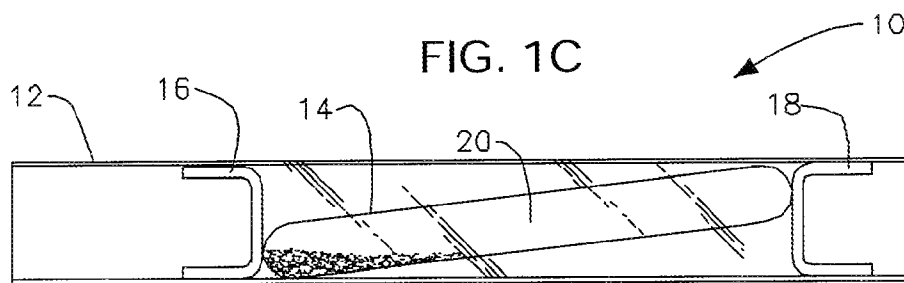
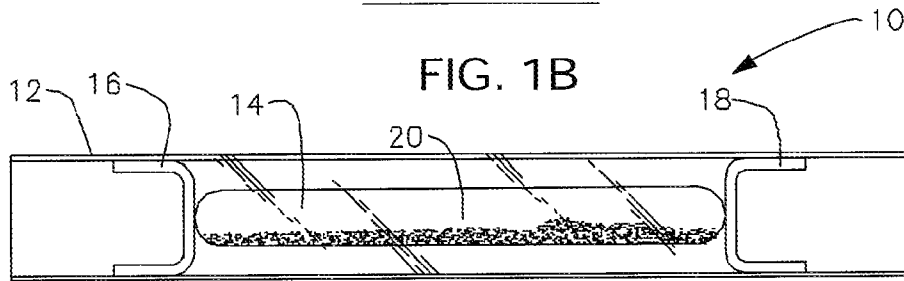

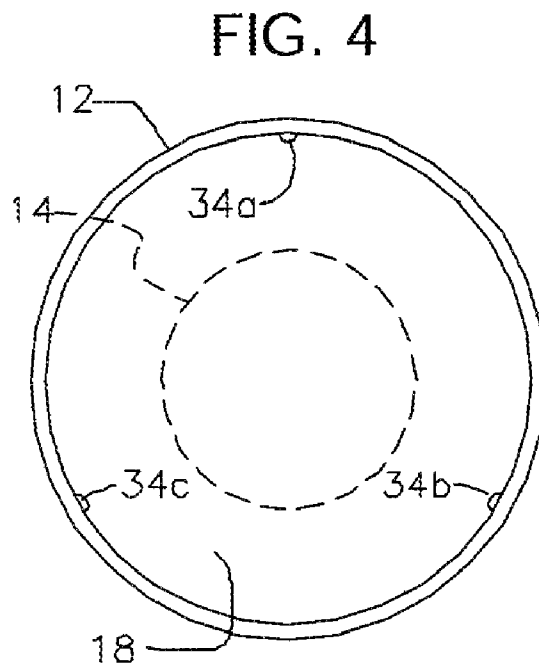
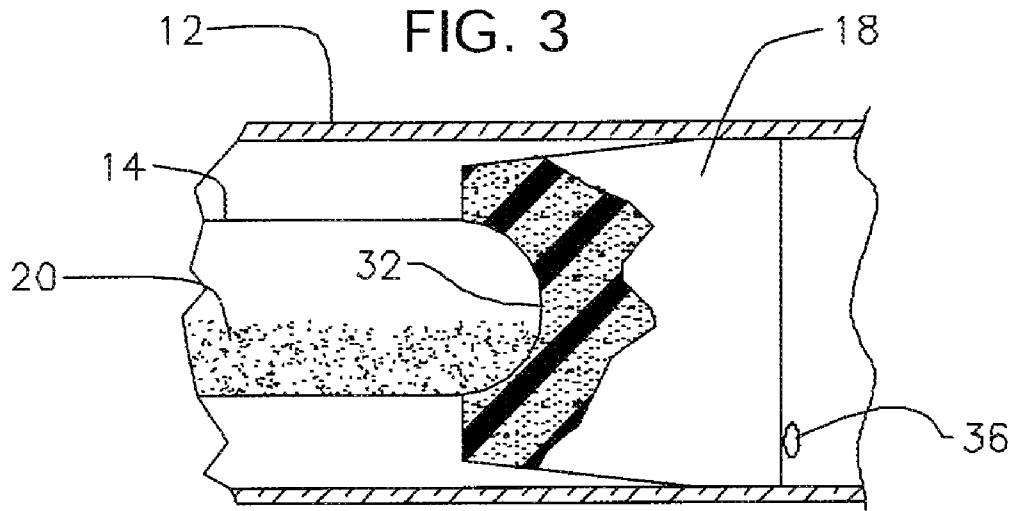

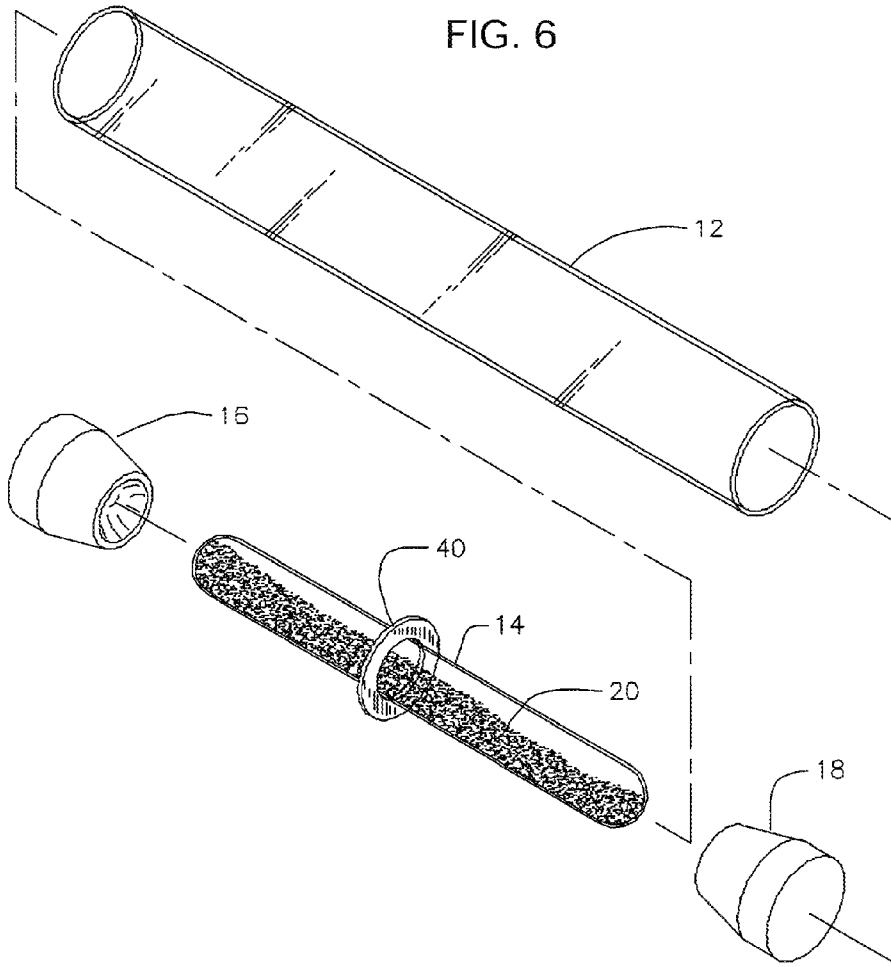
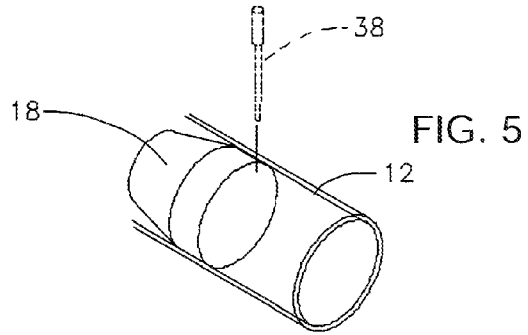

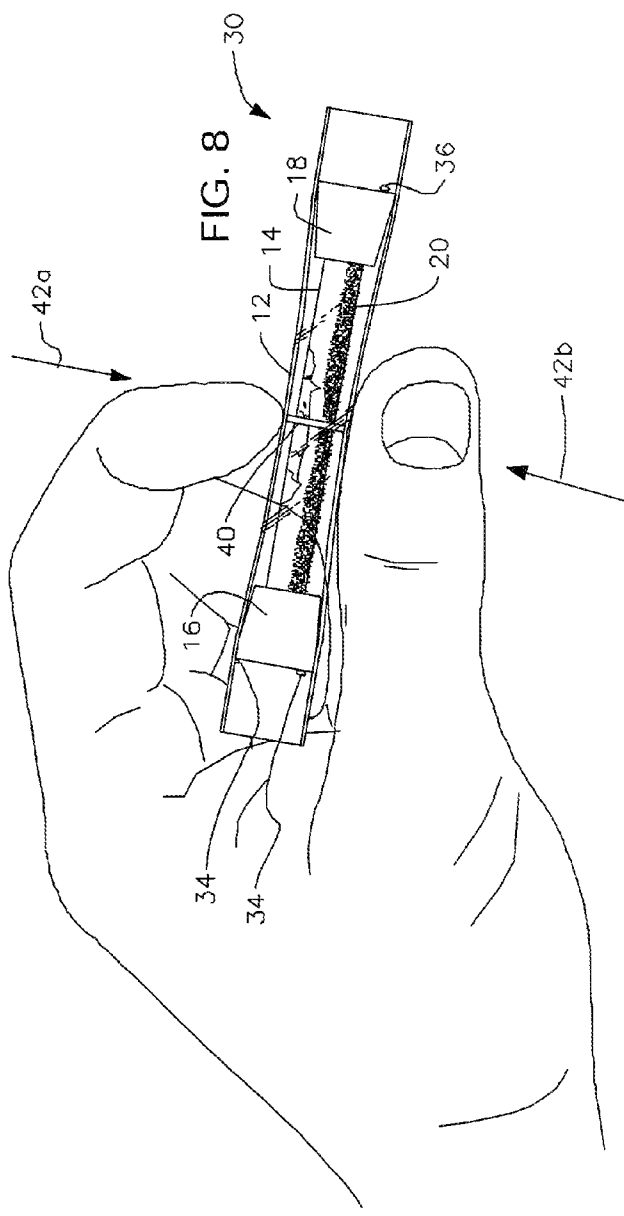
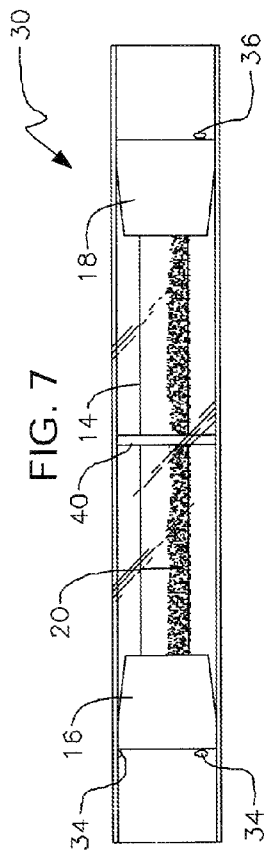

FIG. 9

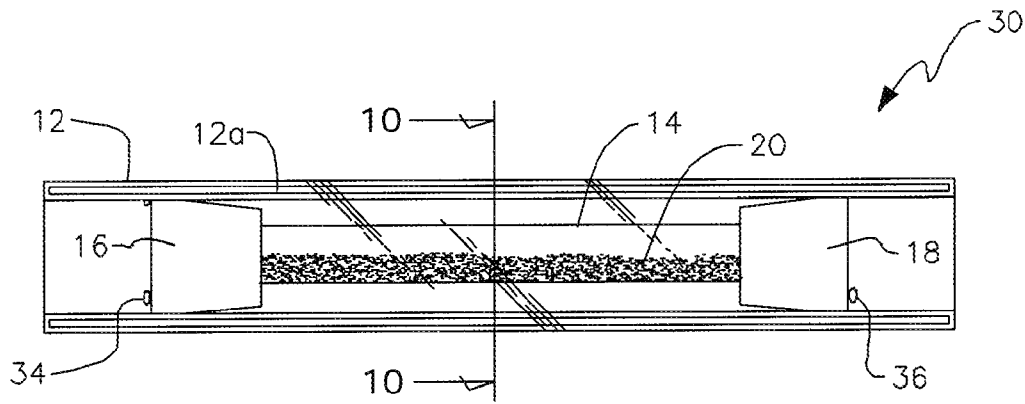
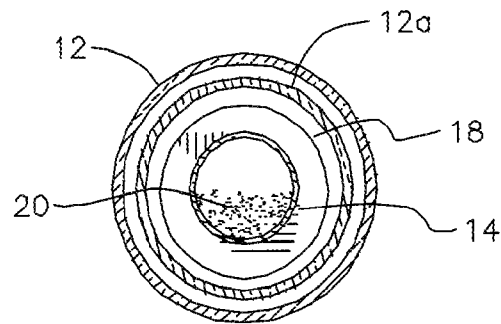

FIG. 10



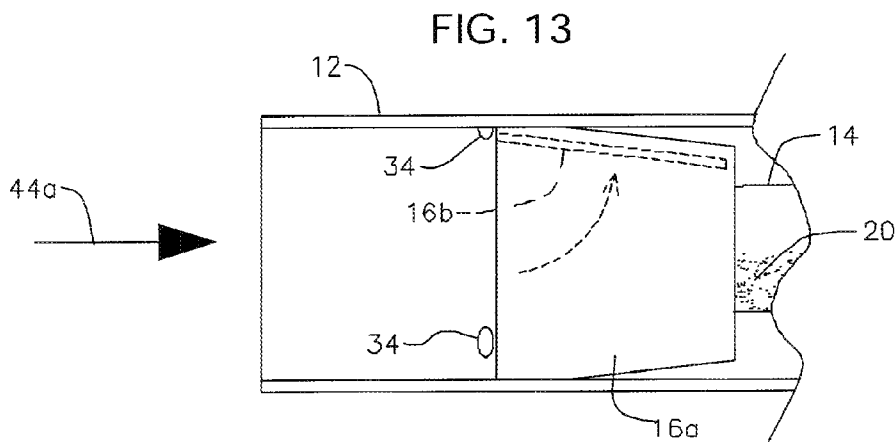
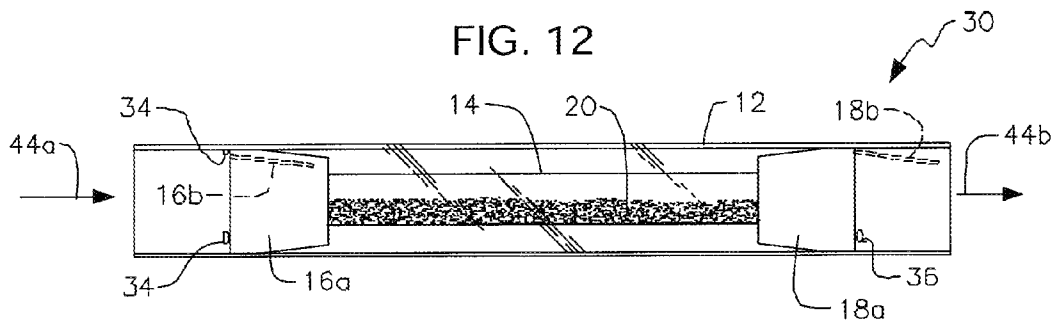
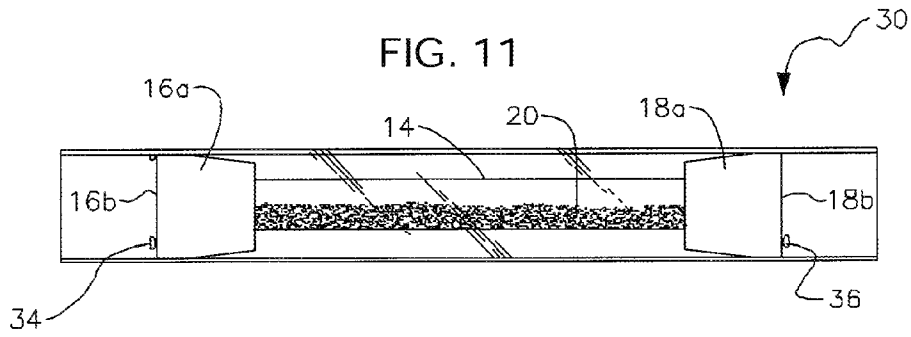

FIG. 14

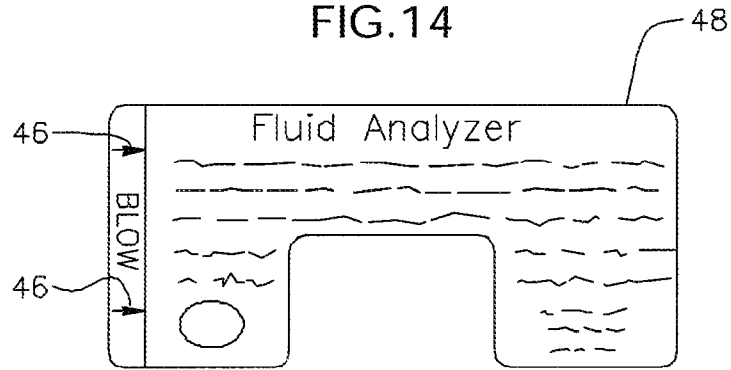

FIG. 15

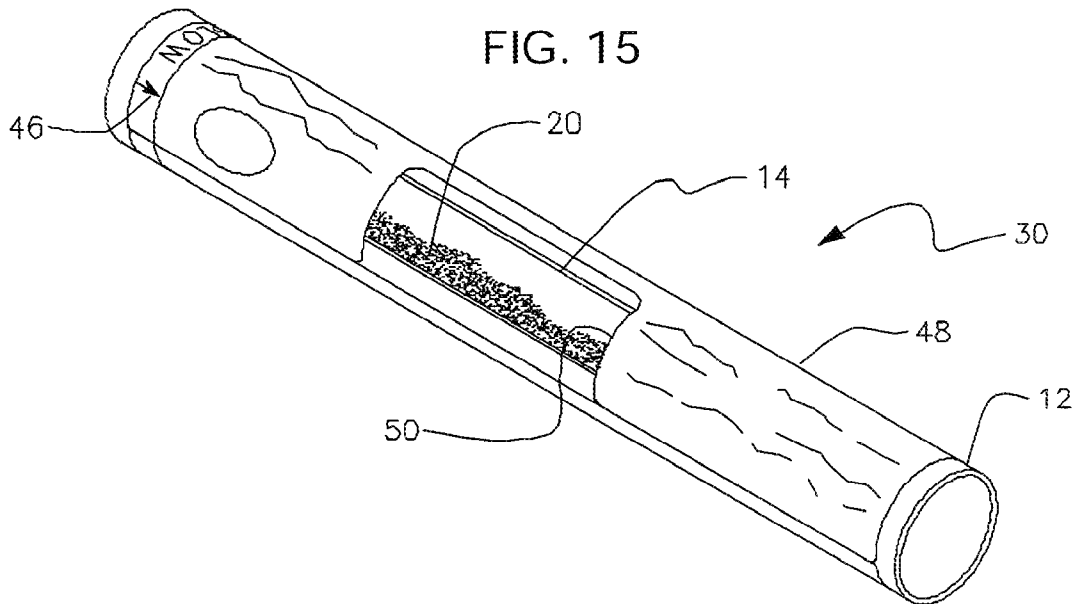

FIG. 16A

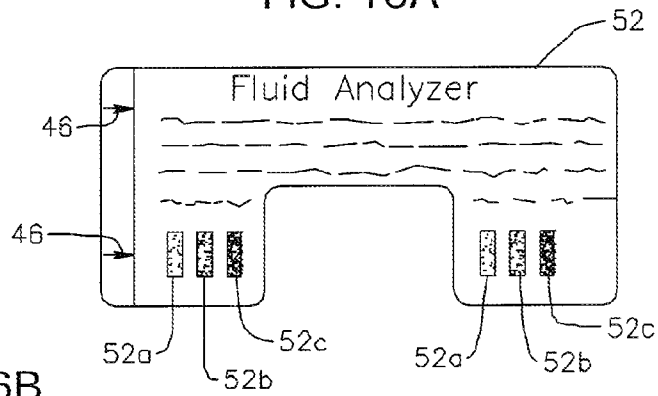

FIG. 16B

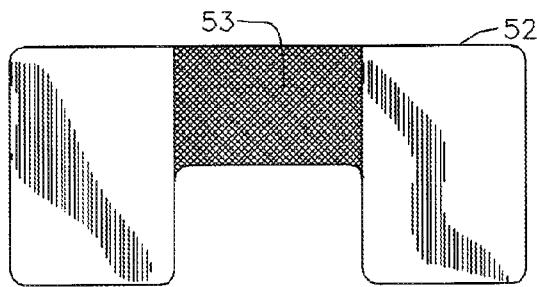

FIG. 17A

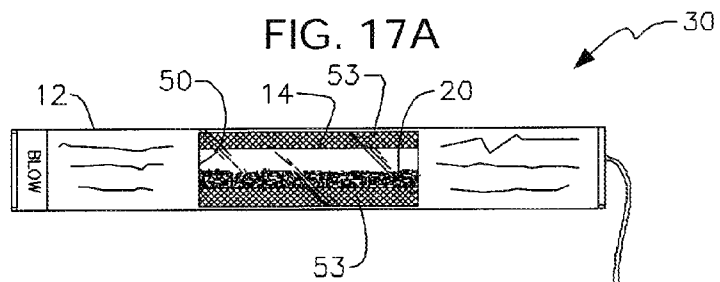
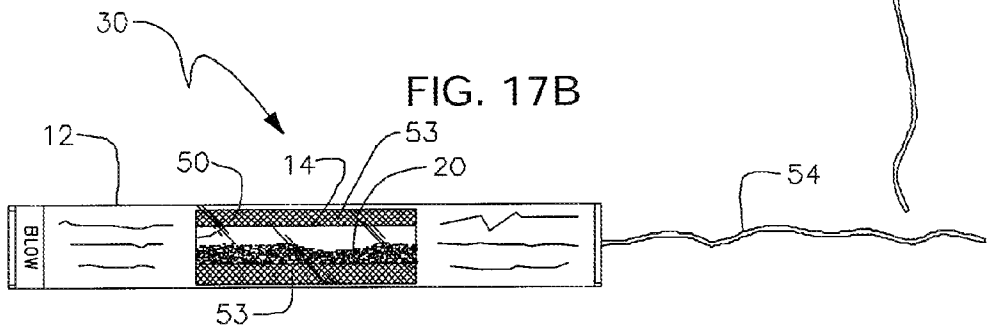
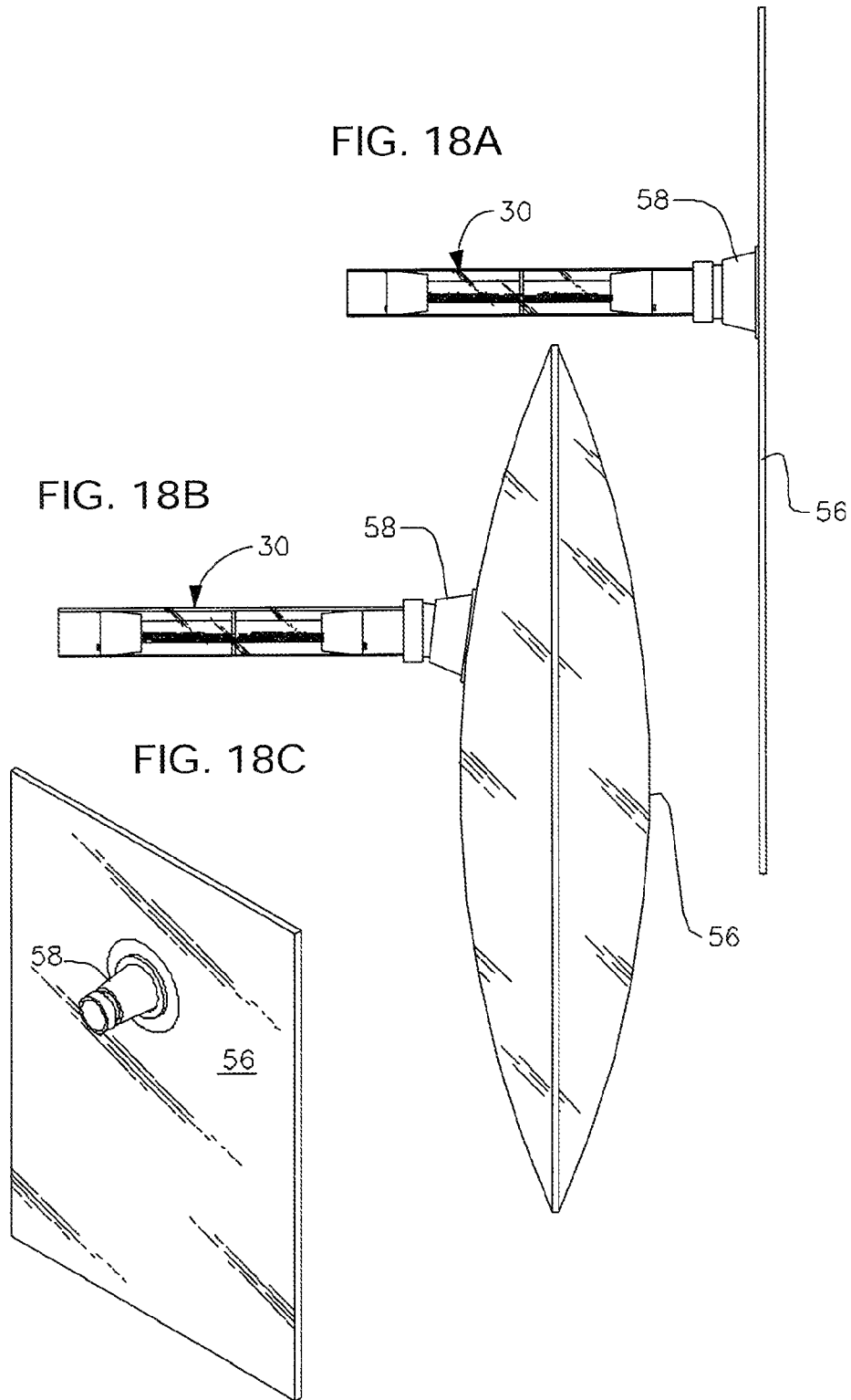
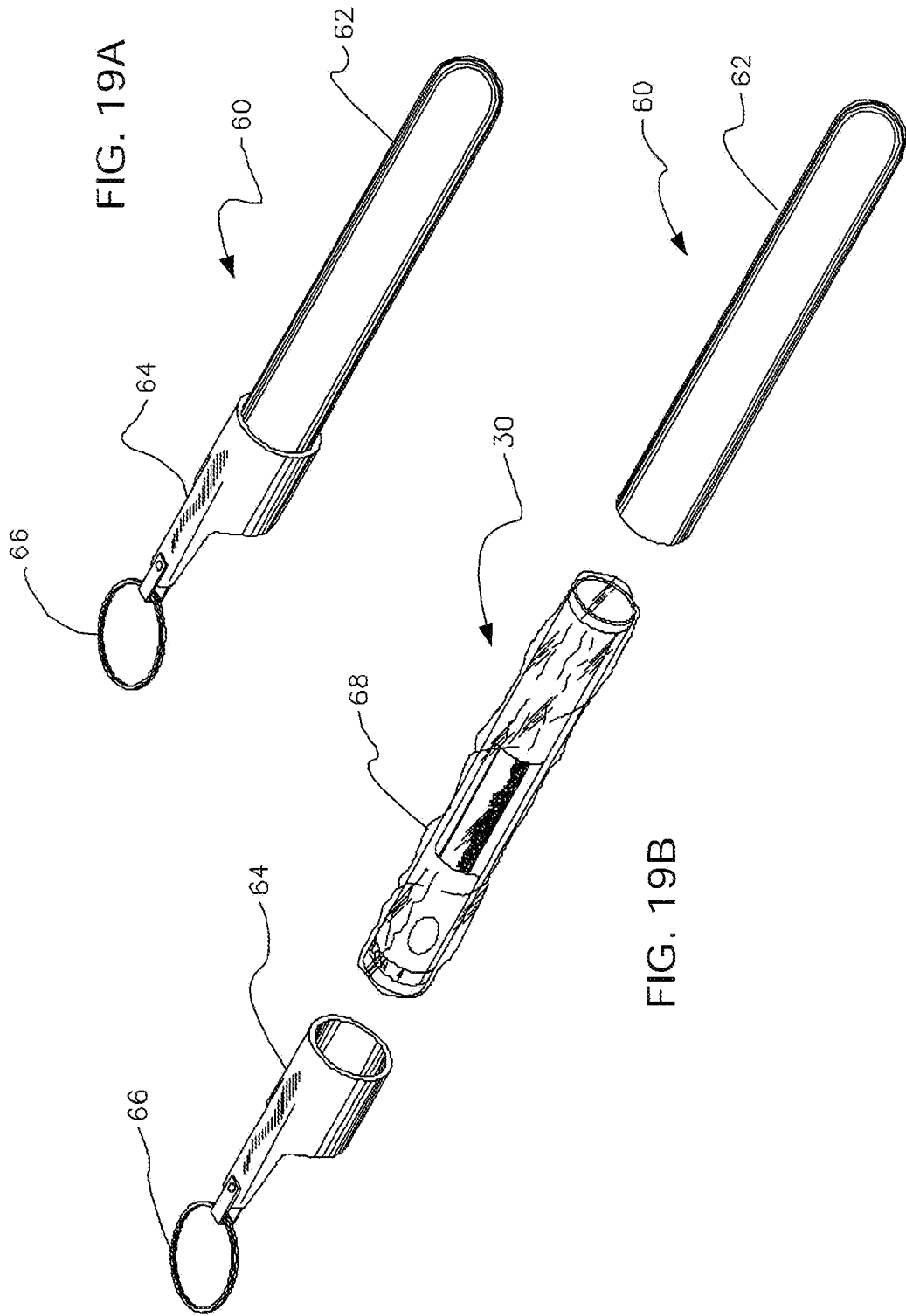
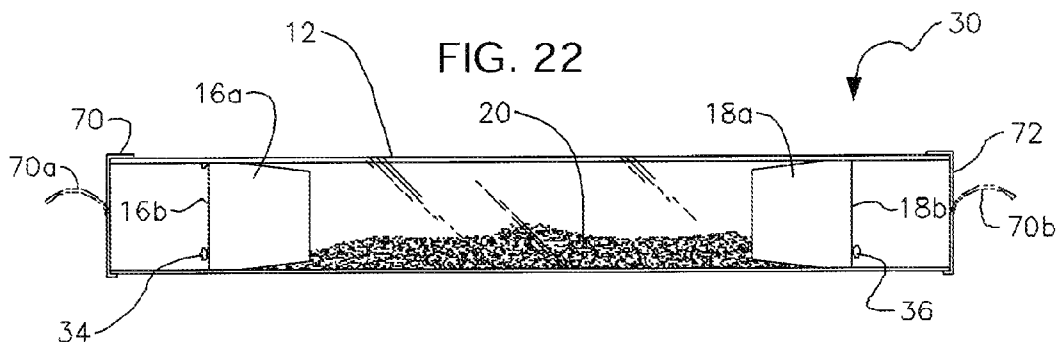
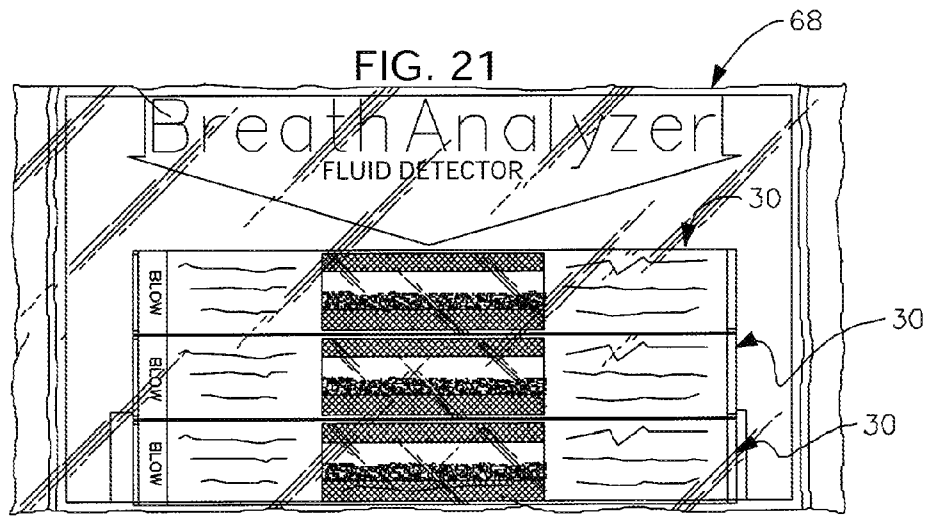

FIG. 17B









HAND-HELD FLUID ANALYZERCROSS-REFERENCE TO RELATED
DISCLOSURE

This disclosure is a divisional application claiming the benefit of the filing date of U.S. patent application entitled: "Hand-Held Fluid Analyzer," by the same inventor, filed on Aug. 19, 2003, bearing Ser. No. 10/604,810, now U.S. Pat. No. 7,285,246.

BACKGROUND OF THE INVENTION

1. Field of the Invention

This invention relates, generally, to disposable, field usable detectors for detecting the presence of substances in test fluids by use of indicator chemistry. More specifically, this invention relates to single-use, disposable devices for efficiently detecting the presence of controlled or other substances in the breath or other fluid by employing chemical indicators that react in a certain prescribed manner to the presence of such substance.

2. Description of the Prior Art

U.S. Pat. No. 4,740,475, awarded Apr. 26, 1988 to Paul, discloses an alcohol detection device that addresses the problem of "chemical indicator freshness." The indicator reagents typically used in these devices tend to deteriorate when exposed to air or moisture prior to use. Thus, the devices have to be handled and stored carefully. The reliability of these types of tests is questionable in the event of breakage or improper sealing.

However, the potential ease of use and reliability of low-cost, throw-away substance detectors using indicator reagent chemistry has continued to encourage researchers to develop a method of insuring the freshness and integrity of the indicator reagents to increase the accuracy and reliability of the tests. Various units and cartridges have been developed containing plugs and seals in an effort to assure indicator reagent freshness.

For example, the detector device shown in the Paul patent has a flexible, deformable housing that forms a test chamber for interacting an indicator reagent with the sample fluid. A rupturable ampoule containing an indicator reagent is positioned within the housing. The indicator reagent completely fills the ampoule and the diameter of the ampoule is only slightly less than the diameter of the lumen of the deformable housing.

Two porous plugs, located at opposing ends of the ampoule, maintain the position of the ampoule within the housing. To use the device, a user ruptures the glass ampoule through application of a predetermined pressure through the walls of the deformable housing. The user then blows through the opening at one end of the device, causing the breath to be exposed to the indicator reagent that has been introduced into the chamber by the breaking of the ampoule. In the presence of the predetermined substance in the sample fluid, the indicator reagent undergoes a known change in color.

The Paul device is characterized as being portable. However, the glass ampoule is easily broken if the device is carried in a pocket or other relatively unprotected container. Thus, the device is portable only when carefully transported.

There is almost no space between an outer housing of vinyl and the glass ampoule therewithin. Thus, the device is extremely fragile, easily broken, and thus is not truly portable. Moreover, the absence of space between the vinyl housing and the glass ampoule can result in cut fingers when the housing is squeezed to break the ampoule.

Thus there is a need for a truly portable detector having enhanced safety features.

Moreover, the ampoule is completely filled with the indicator reagent. This offers significant resistance to fluid flow. Thus, there is a need for an improved detector with less resistance to fluid flow so that a user need not blow as hard as when using the Paul device.

A considerable amount of force may be required to crush the Paul ampoule. A need exists, therefore, for a means that reduces the amount of force that a user must apply to the deformable housing to achieve rupturing of the ampoule.

Glass shards may cut through the vinyl housing and cut a user's finger or thumb when the ampoule is broken. Thus, there is a need for an improved detector structure that reduces the chances that a user will be cut when crushing the ampoule.

A user may also ingest or inhale indicator reagent by breathing inwardly instead of exhaling when using the Paul device. A need therefore exists for an improved detector structure that ensures that no user will be able to ingest or inhale the indicator reagent even if the detector is improperly used.

Visual inspection of the indicator reagent may fail to detect color changes in the indicator reagent because the Paul detector is made primarily of clear materials. The housing is typically formed of clear vinyl and the ampoule is formed of clear glass. Depending upon the amount of background clutter that exists in the ambient environment, a color change may be undetectable. There is a need, therefore, for a way to frame the indicator reagent to enhance the effectiveness of a visual inspection. It would also be advantageous if a way could be found to increase the contrast between the reagent indicator and the background against which the reagent indicator is viewed.

Some indicator reagents turn into a first color when a first concentration of the tested-for substance is present, a second color when a higher concentration is detected, a third color when a still higher concentration is detected, and so on. Thus there is a need for a label containing information about the meaning of the various colors where a detector is provided with such a reagent.

There is also a need for a detector that provides a physical marker indicating whether or not gaseous fluid is flowing through the lumen of the detector.

In view of the fragile nature of the Paul detector, there is also a need for a substance detector that is protected from easy breakage so that it is truly portable.

A need also exists for a detector having no ampoule therein to reduce the cost of manufacturing and also to enhance the safety of the detector by eliminating the glass shards that are produced upon rupturing of an ampoule.

However, in view of the prior art considered as a whole at the time the present invention was made, it would not have been obvious to those of ordinary skill in the pertinent art that the identified needs were in existence nor would it have been obvious how to fulfill such needs if they had been identified.

SUMMARY OF THE INVENTION

The long-standing but heretofore unfulfilled need for a truly portable, hand-held, disposable, field usable, lightweight device for detecting the presence of alcohol or other preselected substances in body fluids, particularly the breath, is now met by a new, useful, and nonobvious invention.

The novel detector includes a vinyl housing that is preferably generally cylindrical in shape and thus has a lumen that extends from a first open end thereof to a second open end

thereof. A rupturable glass ampoule containing an indicator reagent is positioned in the lumen of the vinyl housing.

In a first embodiment, the diameter of the ampoule is less than the diameter of the lumen of the housing to provide a radial space therebetween for safety purposes. Moreover, the ampoule is only about half-filled with indicator reagent to reduce the resistance to fluid flow therethrough after the ampoule has been ruptured.

In the first embodiment, a pair of porous filter members flank the ampoule but no means are provided that prevent the reduced-diameter ampoule from tilting within the housing.

In a second embodiment, the reduced-diameter ampoule is secured within the vinyl housing from slipping out of its optimal position by an improved pair of porous filters, located on opposite ends of the housing, each of which has a concavity formed therein that accepts a corresponding rounded end of the ampoule. In this way, the reduced-diameter glass ampoule is suspended within the vinyl housing, spaced sufficiently away from the deformable walls of said vinyl housing so that inadvertent pressure applied to said vinyl housing does not rupture the ampoule.

In a third embodiment, at least one detent protrudes radially inwardly into the lumen of the deformable housing to prevent sliding displacement of the filters. A punch tool may be advantageously employed to create the detents.

In a fourth embodiment, a slightly compressible washer is positioned mid-length of the ampoule so that when the housing is manually compressed, the force of compression is concentrated by the narrow profile of the washer so that the ampoule breaks with less force than would be required in the absence of such concentration. The washer further spaces the digits of the user further from the glass shards created by the breaking of the ampoule.

In a fifth embodiment, the digits of the user are protected by the provision of a double-walled vinyl housing. This tube-in-tube design doubles the thickness of the walls of the housing, thereby providing an increased safety margin against the glass shards.

A sixth embodiment eschews the porous filters of the first five embodiments and provides hollow plugs having one-way flaps that open only in response to fluid flow in a predetermined direction. The flaps do not open if the user blows into the wrong end of the detector. Moreover, the flaps do not open if the user sucks on the correct end of the housing, thereby preventing ingestion or inhalation of the indicator reagent.

A unique label frames the indicator reagent in a seventh embodiment to enhance the ability of a user to see changes in color of said indicator reagent. The reverse side of the label is dark in color to further facilitate visual inspection of the indicator reagent by increasing the contrast between the indicator reagent and said dark background.

An eighth embodiment provides a label that indicates multiple color changes in the indicator reagent that correspond to multiple concentrations of tested substance so that a user may receive more detailed information than in those embodiments that test only for one threshold of the tested substance.

Any label may also be eliminated by printing the text and graphical material of the label directly onto the tube by screen printing or other suitable printing technique.

Streamers that indicate whether or not a user is blowing through the lumen of the detector are provided in a ninth embodiment. The streamers also indicate the length of time the user is exhaling through said lumen. One or more streamers may be provided and the streamers may take the form of strings, ribbons, tubes, or the like.

In a tenth embodiment, a flexible, inflatable bag is secured to the discharge end of the device in fluid communication

with the lumen of the detector. Thus, the bag is inflated when a user blows through said lumen. A user, therefore, cannot pretend to blow through the lumen without being caught.

In an eleventh embodiment, the detector is made truly portable by being housed within a sturdy container that may be carried in a pocket or other suitable carrier without breakage. In a preferred version of the eleventh embodiment, the sturdy container is provided in the form of a hollow key ring fob having a first part for housing the detector and a second part that provides a closure means. A key ring is secured to the closure means so that it is a simple matter to remove the closure means to enable removal of the detector from the container.

A twelfth embodiment provides a container adapted to hold more than one detector.

A thirteenth embodiment eliminates the ampoule or ampoules employed in the other embodiments. Removable seals are secured to opposite ends of the housing to provide a hermetic seal so that the indicator reagent is not subjected to fluid flow until both seals are removed. The filters are employed as in the other embodiments to contain the indicator reagent therebetween.

A fourteenth embodiment adds a different indicator reagent to each filter of the thirteenth embodiment. This enables simultaneous detection of three different substances.

The novel detector may therefore be summarily described as a truly portable, disposable device for detecting the presence of a substance in a test fluid. The novel device includes a flexible and resilient, deformable first housing of generally cylindrical shape. An ampoule adapted to sealably retain therein an indicator reagent is positioned within the first housing and said ampoule has a diameter substantially less than the diameter of the first housing. The ampoule is adapted to be ruptured when subjected to a manually applied, radially inwardly directed force applied to said first housing.

In the first embodiment, as aforesaid, a first filter member is positioned within a lumen of the first housing in abutting relation to a first end of an ampoule, having a diameter substantially less than the diameter of the first housing, and a second filter member is positioned within the lumen of the first housing in abutting relation to a second end of the ampoule.

The ampoule has rounded opposite ends and is only about half-filled with indicator reagent so that a user need not exert extreme force when blowing through the detector.

In a second embodiment, a first concavity is formed in an inboard end of the first filter member and a second concavity is formed in an inboard end of the second filter member. The first concavity is complementary in size and shape to a convex first rounded end of the ampoule and the second concavity is complementary in size and shape to a convex second rounded end of the ampoule. The indicator reagent undergoes a visually detectible change in the presence of a predetermined amount of the substance. Moreover, the first and second concavities hold the ampoule in substantially coincident relation to a longitudinal axis of symmetry of the first housing.

Each filter has a first, outboard part of circular transverse cross-section so that it fits snugly within the lumen of the housing and a second, inboard part that is tapered downwardly to facilitate sliding introduction of the respective filters into opposite ends of the housing during assembly of the detector.

In a third embodiment, the detector further includes a first detent formed in the housing in outboard relation to the first filter member and a second detent formed in the housing in outboard relation to the second filter member. The first and second filters are constrained against longitudinal travel in an

inboard direction by the ampoule and are constrained against longitudinal travel in an outboard direction by the first and second detents.

A fourth embodiment of the detector includes a compressible washer means having a central aperture. The compressible washer means is positioned about mid-length of the ampoule, and the ampoule is received within the central aperture. The compressible washer means has an outer periphery in substantial contact with an inner wall of the first housing. Accordingly, the manually applied radially inwardly directed force is applied to the compressible washer and causes compression of the central aperture and hence rupturing of the ampoule. The compressible washer provides a spacing between the first housing and the ampoule to reduce the chances that a glass shard from the ruptured ampoule will cut a finger or thumb of an individual applying said manual pressure.

A second flexible and resilient housing ensleeves the first housing in a fifth embodiment. The chance that glass shards, created by a ruptured ampoule in response to application of the manually applied radially-inwardly directed pressure against the first and second housings, will cut a finger or thumb of an individual applying manual pressure is reduced by the presence of the second housing.

In a sixth embodiment, a first hingedly mounted flap is formed in an outboard end of the first filter member. The first flap is adapted to admit fluid flow in one direction only. A second hingedly mounted flap is formed in an outboard end of the second filter member and the second flap is adapted to admit fluid flow in one direction only. Thus, a fluid may flow through the device in only one direction so that the indicator reagent cannot be inhaled.

A label has a first end that wraps completely around a first end of the housing and having a second end that wraps completely around a second end of the housing. The label also has a middle section that wraps partially around said housing to create a window in said middle section. The window enhances visual inspection of the indicator reagent. A dark color is printed on the reverse side of the label so that the color of the indicator reagent is clearly visible against said dark color.

The ampoule may be adapted to contain an indicator reagent that changes into a plurality of differing colors depending upon a percentage of the substance detected in the fluid. A label is secured to the housing and a first plurality of color codes is imprinted upon the label. Each color code indicates a percentage of substance present in the fluid. If the indicator reagent changes color in response to contact with the fluid, visual inspection of the plurality of color codes indicates the percentage of the substance detected in the fluid.

In the alternative, a label-less embodiment may be provided where a color code or color codes may be imprinted directly on the vinyl housing by a suitable printing method. The color code or codes may take the form of a box or boxes of differing colors, or a colored line or lines that partially or fully circumscribe the housing, and so on. As another example, the entire housing could be imprinted so that it has the color that the indicator reagent will change to upon detecting a substance. Where the indicator reagent may change into two different colors upon detection of differing levels of a detected substance, a first half of the housing could be imprinted with the first color and a second half of the housing could be imprinted with the second color, and so on for additional color changes.

An elongate, flexible streamer in the form of one or more strings, ribbons, tubes, or the like, or combinations thereof, is secured to a discharge end of the housing. The streamer is

mounted so that it is in fluid communication with fluid flowing through a lumen of the housing. The streamer remains substantially in a position of repose if fluid is not flowing through the housing and the streamer is displaced from the position of repose when fluid is flowing through the lumen. An amount of time that fluid flows through the lumen may therefore be measured by measuring the amount of time the streamer is displaced from the position of repose.

A flexible, inflatable bag may be secured to the discharge end of the detector, in lieu of the streamer. The bag inflates when a user properly blows through the lumen of the detector and fails to inflate if a user merely pretends to blow through the lumen.

The novel detector is housed in a substantially uncrushable or unbreakable container so that it may be carried in a pocket or other relatively unprotected carrying means without fear of breakage. In a preferred embodiment, the container is attached to a key ring and thus serves as a key fob.

The container may be sized to hold one or more detectors. It may be coated with glow-in-the-dark materials or otherwise treated to make it easy to see in low light conditions.

The ampoule or ampoules that hold the indicator reagent may be eliminated in yet another embodiment. Impregnating or coating the filters with differing indicator reagents may also be employed to enable simultaneous detection of multiple substances.

An important object of the invention is to provide disposable devices for efficiently detecting the presence of a particular substance in human fluids employing chemical indicators that react in a certain prescribed manner in the presence of the substance being tested for.

A more specific object is to provide a unique substance detection device for mobile testing of human breath that is safe, efficient, and effective.

Moreover, it is an important object of this invention to provide a detector having an ampoule that is spaced apart from the housing of the detector for safety purposes.

Another object is to provide an ampoule having less resistance to fluid flow than the ampoules of the prior art.

It is also an important object to provide a means for holding an ampoule of a substance detector in an optimal orientation so that the indicator reagent therewithin is evenly distributed therewithin, thereby increasing the reliability of the detector.

A closely related object is to provide such ampoule holding means so that the ampoule is not subject to unintentional breaking of the type that can occur when the ampoule is disposed in oblique relation to a longitudinal axis of the ampoule housing.

Another important object is to provide a means that prevents such ampoule from slipping within the lumen of the housing.

Another object is to provide a means for reducing the amount of force required to crush an ampoule while increasing the safety of the crushing operation.

Still another object is to provide a housing structure that provides an extra level of protection between a user's finger and thumb and glass shards created by crushing the ampoule.

Yet another object is to provide a detector that does not operate unless a user blows through an indicated end thereof.

Another object is to provide a means that prevents a user from inhaling or ingesting an indicator reagent.

Another object is to provide a unique label that frames the indicator reagent, thereby enhancing the ability of a user to visually detect changes in reagent color.

Another object is to provide a color contrast surface behind the indicator reagent to further facilitate visual observation of color changes in said indicator reagent.

7

A further object is to provide a label that indicates multiple levels of the presence of the substance for which the test is made.

Another object is to provide a label-less housing where all information that could be imprinted upon a label is imprinted directly onto the housing.

A still further object is to provide a means for determining whether or not a user is exhaling through the lumen of the housing, and how long such exhalation is maintained.

Another object is to provide a container for the detector so that the detector is truly portable.

Still another object is to provide a detector having no ampoule therewithin.

Yet another object is to provide a no-ampoule detector where the filters are treated with differing indicator reagents to enable simultaneous detection of multiple substances.

The invention accordingly comprises the features of constructions, combination of elements, and arrangement of parts as set forth in the detailed description that follows, and the scope of the invention will be indicated in the claims.

BRIEF DESCRIPTION OF THE DRAWINGS

For a further understanding of the nature and objects of the invention, reference should be made to the following detailed description, taken in connection with the accompanying drawings in which:

FIG. 1A is a side elevational view of the prior art device disclosed in the Paul patent, indicating the absence of space between the vinyl housing and the glass ampoule therewithin;

FIG. 1B is a side elevational view of a first illustrative embodiment of this invention where the diameter of the ampoule has been reduced;

FIG. 1C is a side elevational view like that of FIG. 1B but where the filters at the opposite ends of the ampoule have slipped from their initial positions, resulting in canting of the improved ampoule;

FIG. 2 is a side elevational view of a second embodiment of the present invention, depicting an untilted ampoule disposed in centered relation with respect to the deformable housing;

FIG. 3 is an enlarged, partially sectional view of the circled area denoted 3 in FIG. 2;

FIG. 4 is an end view of the embodiment of FIG. 2;

FIG. 5 is a perspective view depicting a tool, in phantom lines, employed to form detents in the deformable housing of this invention;

FIG. 6 is an assembly diagram depicting a third illustrative embodiment;

FIG. 7 is a side elevational view of the third embodiment when in repose;

FIG. 8 is a perspective view depicting the third embodiment when crushed;

FIG. 9 is a side elevational view of a fourth embodiment;

FIG. 10 is a transverse sectional view taken along line 10-10 in FIG. 9;

FIG. 11 is a side elevational view depicting the novel filter flaps when in repose;

FIG. 12 is a side elevational view depicting the novel filter flaps when said filter flaps have been displaced from their respective positions of repose;

FIG. 13 is an enlarged, detailed view of one of the filter flaps when displaced from its position of repose;

FIG. 14 is a front elevational view of a first embodiment of the novel label structure;

FIG. 15 is a view depicting the first embodiment of the novel label in its functional position;

8

FIG. 16A is a front elevational view of a second embodiment of the novel label structure;

FIG. 16B is a rear elevational view of said second embodiment of the novel label structure;

FIG. 17A is a side elevational view depicting the novel flow-detecting streamer in repose;

FIG. 17B is a side elevational view depicting the novel flow-detecting streamer in motion;

FIG. 18A is a side elevational view depicting the novel flexible, inflatable bag in repose;

FIG. 18B is a side elevational view depicting the novel flexible, inflatable bag when at least partially inflated;

FIG. 18C is a perspective view of the flexible, inflatable bag depicted in FIGS. 18A and 18B;

FIG. 19A is a perspective view of the assembled novel protective container that houses the detector so that the detector is truly portable;

FIG. 19B is an exploded perspective view depicting the protective container, its closure means, and the novel detector;

FIG. 20 is an exploded perspective view depicting a container adapted to hold more than one detector;

FIG. 21 is an elevational view depicting a plurality of detectors in a flat polybag; and

FIG. 22 is an elevational view of an embodiment having no filter members.

Similar or identical reference numerals are used throughout the drawings to indicate similar or identical parts that are common to the several embodiments of the invention.

DETAILED DESCRIPTION OF THE PREFERRED EMBODIMENT

Referring now to FIG. 1A, it will there be seen that a detector of the prior art, disclosed in the above-identified patent to Paul, is denoted as a whole by the reference numeral 10. Note that there is no space between deformable housing 12 of vinyl construction and glass ampoule 14. Thus, when glass ampoule 14 is crushed by squeezing vinyl housing 12, the fingers employed in the crushing operation may be cut by glass shards generated by such crushing because the glass shards easily cut through vinyl housing 12.

FIG. 1B depicts the first embodiment of this invention. The diameter of glass ampoule 14 is reduced so that space is provided between vinyl housing 12 and glass ampoule 14. Thus, there is an increased measure of protection from glass shards, as compared to the patented embodiment of FIG. 1A. Moreover, ampoule 14, in the improved embodiment of FIG. 1B, is no longer completely filled. Instead it is about half full to make it easier to blow through detector 10 when ampoule 14 has been broken.

However, as indicated in FIG. 1C, one or both of the filters at the opposite ends of the reduced-diameter ampoule of FIG. 1B may slip from their initial positions, allowing ampoule 14 to become tilted, or canted, within the substance detector housing. When this occurs, the tilt of the ampoule causes the chemical grains therewithin to tend to accumulate toward one end of the ampoule. If the accumulation becomes excessive, it can alter the effectiveness of the indicator.

Moreover, when ampoule 14 is oblique to a longitudinal axis of the housing, it becomes subject to unintentional, premature breakage because its ends may abut the housing and be easily ruptured even if relatively light, inadvertent pressure is applied to the housing.

The deformable character of housing 12 presupposes some elasticity so that housing 12 returns substantially to its original cylindrical shape after a user squeezes it to break glass

ampoule **14**, i.e., housing **12** is flexible and resilient. Accordingly, sufficient volume is provided to form the test chamber. However, the entire housing need not be deformable. Only that portion of housing **12** proximate to ampoule **14** need have sufficient deformability to transmit pressure to ampoule **14**.

Even though the amount of indicator reagent **20** encapsulated within ampoule **14** is reduced by about half in this invention, vis a vis the amount of indicator reagent used in the prior art, the amount is still effective. The amount of indicator reagent within ampoule **14** is calculated to suit the internal capacity of the test chamber and the amount of body fluid, whether liquid or gaseous, to be introduced into the lumen of detector **10**.

Ampoule **14** is preferably positioned in the center of housing **12** in equidistantly spaced relation from the opposite ends of said housing. However, in FIG. 1C, filters **16**, **18** have slipped from their respective optimal positions as aforesaid. Accordingly, ampoule **14** is not centered with respect to said housing.

Note further that housing **12** and ampoule **14** are both of clear, transparent construction. Thus, there is no means for framing indicator reagent **20** to facilitate visual inspection thereof. Nor is there any means for increasing the contrast between the indicator reagent and its background.

The ideal deployment of indicator reagent **20** includes no accumulations, i.e., the indicator reagent should be spread evenly between the opposite ends of ampoule **14**. Any variance between ideal deployment and actual deployment introduces errors into the detection function performed by detector **10**.

The patented version of the Paul detector (FIG. 1A) solves the canting problem by sizing the ampoule to have an outer diameter substantially equal to the inner diameter of the vinyl housing. Although such sizing prevents canting of the ampoule, it increases the chances that the fingers or thumb of a user will be cut at the moment the ampoule is crushed, as mentioned earlier.

The canted-ampoule problem is resolved by the second embodiment of this invention, denoted as a whole by the reference numeral **30** in FIG. 2. The longitudinal axis of symmetry of ampoule **14** is coincident with a longitudinal axis of symmetry of housing **12**, with the result that indicator reagent **20** is evenly distributed within ampoule **14**, even though the amount of said indicator reagent is only about half of the amount used in prior art detector **10** of FIG. 1A.

Centering of ampoule **14** as depicted in FIG. 2 is accomplished by forming concavity **32** in the inboard end of each filter **16**, **18**. FIG. 3 depicts concavity **32** formed in filter **18**; the concavity formed in filter **16** has the same construction. As indicated in FIG. 3, the radius of curvature of each concavity is equal and complementary to the radius of curvature of the rounded ends of ampoule **14** so that the ends of said ampoule are perfectly seated within their respective concavities in stable, non-shifting relationship therewith. This structure maintains ampoule **14** in floating or suspended relation to the cylindrical walls of housing **12**.

Each filter **16**, **18** is formed of a firm but resilient porous material. Note that the inboard end of each filter **16**, **18** has a diameter-reducing taper formed therein. More particularly, the respective outboard ends of each filter **16**, **18** are circular in transverse cross section to ensure a snug fit with the lumen of tubular housing **12**. The respective inboard ends are downwardly tapered to facilitate sliding introduction of the filters into the opposite ends of said housing.

In addition to providing an even distribution of indicator reagent **20**, the filters having concave inboard faces also solve the problem of breakage associated with a canted ampoule of

the prior art. The spacing between housing **12** and ampoule **14** is sufficient to avoid unintentional breakage of the latter when the former is slightly compressed in a radially inwardly direction.

However, the concavities do not solve the problem associated with unwanted longitudinal displacement of the filters of the type depicted in FIG. 1. The solution to that problem is embodied in the third embodiment of the invention which is also depicted in FIG. 2. At least one radially inwardly projecting protrusion **34** is formed in deformable housing **12** in outboard relation to filter **16** and at least one radially inwardly projecting protrusion **36** is formed in deformable housing **12** in outboard relation to filter **18**. Each protrusion **34**, **36** provides a detent means that prevents sliding of said filters away from ampoule **14**. Thus, ampoule **14** prevents travel of the filters in an inboard direction and detents **34**, **36** prevent travel of the filters in an outboard direction.

As depicted in FIG. 4, multiple protrusions may be formed in said deformable housing **12**. In the example of FIG. 4, three protrusions **34a**, **34b**, and **34c** are disposed in equidistantly and circumferentially spaced apart relation to one another. Protrusions **34a**, **34b**, **34c** collectively provide detent **36**.

By preventing longitudinal slipping of filters **16**, **18**, ampoule **14** is maintained in centered relation to housing **12** at all times.

Detent **36** may be formed by any suitable means. FIG. 5 depicts a punch tool **38** in phantom lines, but other means for forming such detent are within the scope of this invention.

A fourth embodiment of the invention is depicted in FIGS. 6-8. In those Figs., a washer **40** is positioned substantially mid-length of ampoule **14**. Washer **40** is formed of a firm but deformable material so that when radially-inwardly directed forces are applied to washer **40**, said washer is compressed. More particularly, the diameter of the central aperture of said washer is compressed in response to such forces. Thus, as best understood by comparing FIGS. 7 and 8, depicting the in-repose and the squeezed conditions of housing **12**, respectively, a manual application of converging forces, indicated by single-headed directional arrows **42a**, **42b** in FIG. 8, causes the diameter of the central aperture of the washer to decrease and to break glass ampoule **14**.

Because washer **40** has a narrow profile, its central aperture, when compressed, applies a highly concentrated force against said ampoule **14**. Therefore, less power is required to break ampoule **14** when said washer is provided.

Moreover, as is clear from FIGS. 7 and 8, washer **40** also provides the service of spacing the user's finger and thumb further from the broken pieces of glass that are created when ampoule **14** is crushed. Such spacing reduces the likelihood of an injury.

Ampoule **14** may also be scored or otherwise weakened at a preferred rupture point.

A second means for reducing the chances of such an injury is included in the fifth embodiment, depicted in FIGS. 9 and 10. In this embodiment, housing **12** is double-walled, i.e., a second housing, denoted **12a**, is disposed within original housing **12**, in a tube-in-tube structure. Accordingly, the amount of material, such as vinyl, disposed between the glass shards and the user's digits is doubled. This double shielding provides an enhanced safety factor.

Porous filters **16**, **18** are eliminated in the sixth embodiment. As depicted in FIGS. 11-13, end pieces **16a**, **18a** are not formed of a porous material. Instead, hinged flap **16b** is mounted at the leading end of end piece **16a** and hinged flap **18b** is mounted to the trailing end of end piece **18a**. Flaps **16b**, **18b** are in repose in FIG. 11 because no gaseous or liquid fluid is flowing through housing **12**. In FIG. 12, said flaps **16b**, **18b**

are displaced by a fluid flow indicated by single-headed directional arrows **44a**, **44b**. The hinges may be living hinges or other suitable hinge means.

A more detailed view of flap **16b** is provided in FIG. **13**. It should be understood that neither flap **16b**, **18b** will open if a user blows into housing **12** in a direction opposite to the direction indicated by directional arrows **44a**, **44b**. In a commercial embodiment of the invention, one or more directional arrows **46** (see FIGS. **14-16A**) indicating the required directional flow of the user's breath will be provided. The term "blow" (see FIGS. **14**, **15**, and **17A**, **17B**) may also accompany said directional arrows for emphasis or redundancy. Thus, a person too inebriated to blow into the correct end of detector **30** will automatically fail the sobriety test provided by said detector.

The seventh embodiment of this invention provides a window for enhancing the viewing of indicator reagent **20**. Label **48**, depicted in its flat, front configuration in FIG. **14**, is wrapped around housing **12** in the manner depicted in FIG. **15** to create a physical window **50** that enhances the ability of a user to visually detect changes in indicator reagent **20**. Window **50** provides a frame that isolates indicator reagent **20** in a way not provided in the prior art design.

In a variation of this embodiment, the text or graphic materials appearing on the front surface of label **48** is imprinted directly onto housing **12** by screen printing or other suitable printing method. Lines printed on housing **12** could perform the function of demarcating a viewing window.

Some indicator reagents turn a first color when a first concentration of a substance is detected, a second color when a higher concentration is detected, and so on. The eighth embodiment of this invention thus provides color-coded label **52** of FIG. **16A**. Box **52a** has a first predetermined color and may be labeled "0.04%." Box **52b** has a second predetermined color and may be labeled "0.08%." Box **52c** has a third predetermined color and may be labeled "0.10%." In this way, a user may match the color of the indicator reagent after use with the color of one of said boxes and thus learn the alcohol (or other substance) content of the breath or other bodily fluid. Any number of boxes and corresponding concentration percentages may be provided, as long as each box has a specific and unique color and matches the color to which the reagent changes when exposed to alcohol or other substance of sufficient concentration to cause the indicator reagent to change to the corresponding color.

FIG. **16B** depicts the reverse side of label **52**. Note that middle section **53** thereof is printed black, dark blue, or some other preselected color that sharply contrasts with indicator reagent **20** both before and after said indicator reagent has changed color.

FIGS. **17A** and **17B** illustrate how dark middle section **53** provides an enhanced background contrast to further facilitate visual inspection of the indicator reagent after it has undergone one or more color changes.

In a variation of this embodiment, the entire front surface of label **52** may be printed in the color to which indicator reagent **20** changes when a preselected level of substance is detected. In another variation, where two levels of substance may be indicated, the left half of label **52** could be printed in the color that indicates a first level of substance has been detected and the right half of the label could be printed in the color that indicates a second level of substance has been detected. Where a reagent capable of changing into three different colors, depending upon the amount of substance detected, the left third of the label could be printed in a first color indicating detection of a first level of substance. The middle of the label (the part including window **50**) could be printed in a second

color indicating detection of a second level of substance, and the right third of the label could be printed in a third color indicating detection of a third level of substance, and so on for detectors that can change colors four or more times in response to detection of different levels of detected substances.

Labels **48** and **52** could also be obviated and the textual and graphic materials thereon imprinted directly to housing **12**, as in the preceding embodiment. Housing **12** could be imprinted with a first color to which the indicator reagent changes upon detection of a target substance, with two colors if the indicator reagent responds to differing levels of detected substance by changing colors twice, and so on.

The eighth embodiment, depicted in FIGS. **17A** and **17B**, provides a light-in-weight streamer **54**, or possibly a plurality of such streamers, secured to the exit end of housing **12**. Each streamer **54** may take the form of a flexible string, ribbon, tube, or other suitable structure, or combinations thereof. The streamers defeat the intentions of a user who tries to blow past housing **12** and not through its lumen because said streamers deploy into the FIG. **17B** position only when air passes through said lumen of said housing. The streamer or streamers also facilitate measurement of the length of time that the user has exhaled through said lumen. The length of exhalation is important because an exhalation that does not last a sufficient time will fail to cause indicator reagent **20** to change color. The amount of time for a reagent to change color if the tested substance is present is typically a few seconds.

The ninth embodiment, depicted in FIGS. **18A**, **18B**, and **18C**, provides a flexible, inflatable bag **56** secured at nozzle **58** to the exit or discharge end of detector **30** in fluid communication with the lumen thereof. Bag **56** also defeats the intentions of a user who tries to blow past housing **12** and not through its lumen because flexible, inflatable bag **56** is at least slightly filled as depicted in FIG. **18B** when air passes through said lumen. Bag **56** also facilitates measurement of the length of time that the user has exhaled through said lumen. For example, if it takes five (5) seconds to fill bag **56**, it should be quite obvious if a user has blown into the bag for an ineffective time of just a second or so. Most indicator reagents will detect a substance and change color in about two seconds so a half-filled bag, in such a case, would indicate that the user has blown into detector **30** for at least the minimum amount of time. FIG. **18C** provides a perspective view of said flexible, inflatable bag when it is not connected to detector **30**.

Bag **56** may also be squeezed after use to empty its contents so that the user may be immediately re-tested.

FIGS. **19A** and **19B** provide an exploded and assembled view, respectively, of a container **60** that makes detector **10** truly portable. Main body **62** of container **60** is formed of a high impact plastic, as is closure means **64**. Main body **62** has a closed end and an open end that is selectively closed by said closure means **64**. In this way, container **60** protects detector **30** from breakage even if container **60** with detector **30** there-within is carried in a pocket or other transport means that subjects container **60** to repeated blows of the type that could break detector **30** were it not protectively housed.

Advantageously, when provided in the form of a key fob connected to key ring **66** as depicted, container **60** is attractive and will always be carried by its user since keys are always carried. It is a simple matter to replace detector **30** after use, i.e., container **60** need not be re-purchased when a new detector **30** is purchased.

Detector **30** is preferably wrapped by a paper instruction sheet and said instruction sheet is wrapped in a thin, flexible sheet of plastic **68**, also known as a polybag. Plastic **68** maintains detector **30** in a sterile condition and also serves to

13

snugly pack detector **30** within the hollow interior of main body **62**, as best understood in connection with FIG. **19b**, to provide still further protection against unintentional breakage of said detector during transport.

Nor is container **60** restricted in size so that it holds but one detector **30**. As indicated in FIG. **20**, container **60** may be sized to receive two, three, or more detectors.

Container **60**, without regard to its size, may be covered with a light-reflective material to make it easy to see in low light conditions. It may also be covered with phosphorescent or luminescent materials so that it glows in the dark. It may also be provided in bright colors. A container may also include all of such features or any two of them.

However, detector **30** may also be sold as depicted in FIG. **21**, i.e., without any container **60**. This is the preferred method of packaging when re-fills are being sold. Thus, after a detector **30** is taken from a container **60** and used, the user need not re-purchase container **60** just to get another detector **30**. Instead, detector **30** is sold as depicted in FIG. **21**, with the paper instruction sheet and polybag **68** being in a flat, unrolled configuration. Polybag **68** is depicted with three (3) detectors therein, but it could contain only one (1) or two (2) detectors as well. A larger polybag could hold more than three (3) detectors **30**.

The improved detection devices in accordance with this invention can be used to detect predetermined chemical concentrations of indicated substances in both liquid and gaseous body fluids. The indicator material can include more than one substance and can be contained in a single capsule or within separate capsules. The housings that form the test chamber may be pre-manufactured single disposable units or can be a part of a kit that allows for different sealed rupturable ampoules of indicator reagent to be insertable into housing **12** to test for different types of substances to detect the presence of legal or illegal drugs. Tests could also be conducted for halitosis, diabetes, or other medical condition that produces a tell-tale odor.

Likewise, housing **12** must provide a test chamber of structural integrity when subjected to the reagent(s), sample fluid and any interaction of the two. Thus, the housing must be substantially impermeable to and insoluble in such substances, as well as substantially impermeable to ambient environment. Vinyl is the preferred material for said housing.

However, any deformable substance that allows sufficient pressure or force to be applied through the wall of the housing to fracture ampoule **14** while having sufficient thickness and resistivity to avoid being punctured by random pressures from outside the housing as well as from glass fragments from the ruptured vessel is acceptable.

In a preferred embodiment, housing **12** is formed from a material such as polyvinyl chloride, a neoprene, polyester, or other inert, transparent or translucent flexible material that can be shaped into tubing of desired diameter. An exemplary tubing has a diameter of approximately $\frac{3}{8}$ " and is relatively thin-walled, i.e., in the range of from $\frac{1}{32}$ " to $\frac{1}{64}$ " thickness. The tubing may be flared at the entry end to form a funnel for urine and other liquid test fluids.

The material from which ampoule **14** is formed is substantially inert to and insoluble in the test fluid, reagent(s) and the ambient environment. Ampoule **14** must be capable of containing a solid, liquid or gaseous reagent and is preferably of thin-walled, easily rupturable construction. Suitable materials include glass, plastic and the like.

Ampoule **14** may also be segmented or compartmentalized through the use of dividers, or some other means to separate plural reagents from one another. The dividers may be porous or non-porous. When plural reagents are used, one of them

14

may be dedicated to the detection of alcohol, one of them may be dedicated to the detection of marijuana, one may be dedicated to the detection of cocaine, and so on.

There may also be plural ampoules within a single housing, where each ampoule includes a different indicator reagent dedicated to detection of a different substance. The user must rupture all of the ampoules before using a detector of that type.

Ampoule **14** is thin-walled and may be formed of glass that has been slightly scored at or near the center. A relatively small pressure at the central area of housing **12** is therefore sufficient to rupture the walls of ampoule **14** without shattering it.

In an unillustrated embodiment, ampoule **14** has an open end upon which a membrane is mechanically placed by the ampoule manufacturer. Such ampoules have utility for housing heat-sensitive reagents.

The reagents which serve as the indicator material can be doped on a substrate or permeated into a porous substrate for release in the presence of a second solvent. It will be apparent to the skilled artisan that a number of permutations and combinations of reagents, solvents, substrates and the like can be configured proximate the test chamber in one or more vessels for single or sequential release to provide an integral, self-contained, disposable unit having a myriad of applications.

A thirteenth and fourteenth illustrative embodiment are depicted in FIG. **22**. Note the absence of any ampoule **14** in these embodiments. The opposite ends of housing **12** are hermetically sealed by seals **70**, **72** having respective pull tabs **70a**, **70b**. The seals are removed by pulling on said pull tabs when detector **30** is to be used. Indicator reagent **20** is contained between filters **16a** and **18a**. Thus, housing **12** need not be formed of a flexible and resilient material because said housing is not squeezed prior to use. The user merely removes seals **70**, **72** and blows through the lumen of the housing. The indicator reagent changes color upon detection of a preselected substance just as in the above-described embodiments. Such thirteenth embodiment may also incorporate the streamers, the bag, the labels, and other elements of the first-described embodiments.

The fourteenth embodiment has the same structure as the thirteenth, but filters **16a** and **18a** are impregnated, coated, or otherwise treated with indicator reagents that differ from indicator reagent **20** positioned therebetween. For example, said filters could be treated with an indicator that changes color upon detection of cocaine. Thus, the breath of an inebriated cocaine user blowing into the lumen of detector **30** would activate both indicator reagents substantially simultaneously. Moreover, the filters could be treated with different indicator reagents so that the breath of an inebriated cocaine and marijuana user would substantially simultaneously activate all three of the indicator reagents.

A legend would be provided on the label as in the earlier embodiments to indicate what each color change indicates. Thus, although the structure of a FIG. **22** embodiment could include as many as three different indicator reagents, all reagents would operate independently of one another so a corporation interested only in marijuana testing, for example, could still purchase such embodiment.

It should also be observed that the indicator reagent could take forms other than powder or grain. For some tests, litmus paper could be provided in lieu of powder **20**.

It will thus be seen that the objects set forth above, and those made apparent from the foregoing description, are efficiently attained. Since certain changes may be made in the above construction without departing from the scope of the invention, it is intended that all matters contained in the

15

foregoing description or shown in the accompanying drawings shall be interpreted as illustrative and not in a limiting sense.

It is also to be understood that the following claims are intended to cover all of the generic and specific features of the invention herein described, and all statements of the scope of the invention that, as a matter of language, might be said to fall therebetween.

Now that the invention has been described,

What is claimed is:

1. A disposable device for detecting the presence of a first substance in a test fluid, comprising:

a housing of generally cylindrical shape;

a first porous filter positioned within a lumen of said housing;

a second porous filter positioned within a lumen of said housing in longitudinally spaced relation to said first porous filter;

said first and second porous filters being snugly received within said lumen of said housing;

a first indicator reagent disposed between said first and second porous filters;

a first hermetic seal secured to a first end of said housing;

a second hermetic seal secured to a second end of said housing;

at least one porous filter of said first and second porous filters being treated with a second indicator reagent that reacts to a second substance in the breath of said user;

whereby a user blows through said lumen and said second indicator reagent undergoes a visually detectible change in the presence of a predetermined amount of said second substance in the breath of said user;

16

whereby said first and second hermetic seals are removed from said housing when said disposable device is to be used;

whereby a user blows through said lumen and said first indicator reagent undergoes a visually detectible change in the presence of a predetermined amount of said first substance in the breath of said user; and

whereby said housing need not be subjected to compressive forces.

2. The disposable device of claim 1, further comprising: said first and second porous filters being treated with a second and third indicator reagent, respectively, that independently react to the presence of a predetermined amount of a second and a third substance in the breath of said user;

whereby a user blows through said lumen and said second and third indicator reagents undergo a visually detectible change in the presence of a predetermined amount of said second and third substances in the breath of said user.

3. The detector of claim 1, further comprising:

a label applied to said detector;

said label including color-coded information concerning the meaning of a color change of said first indicator reagent;

said label including color-coded information concerning the meaning of a color change of said second indicator reagent.

4. The detector of claim 1, further comprising: said first indicator reagent having a form selected from a group of forms including grain, powder, and litmus paper.

* * * * *