

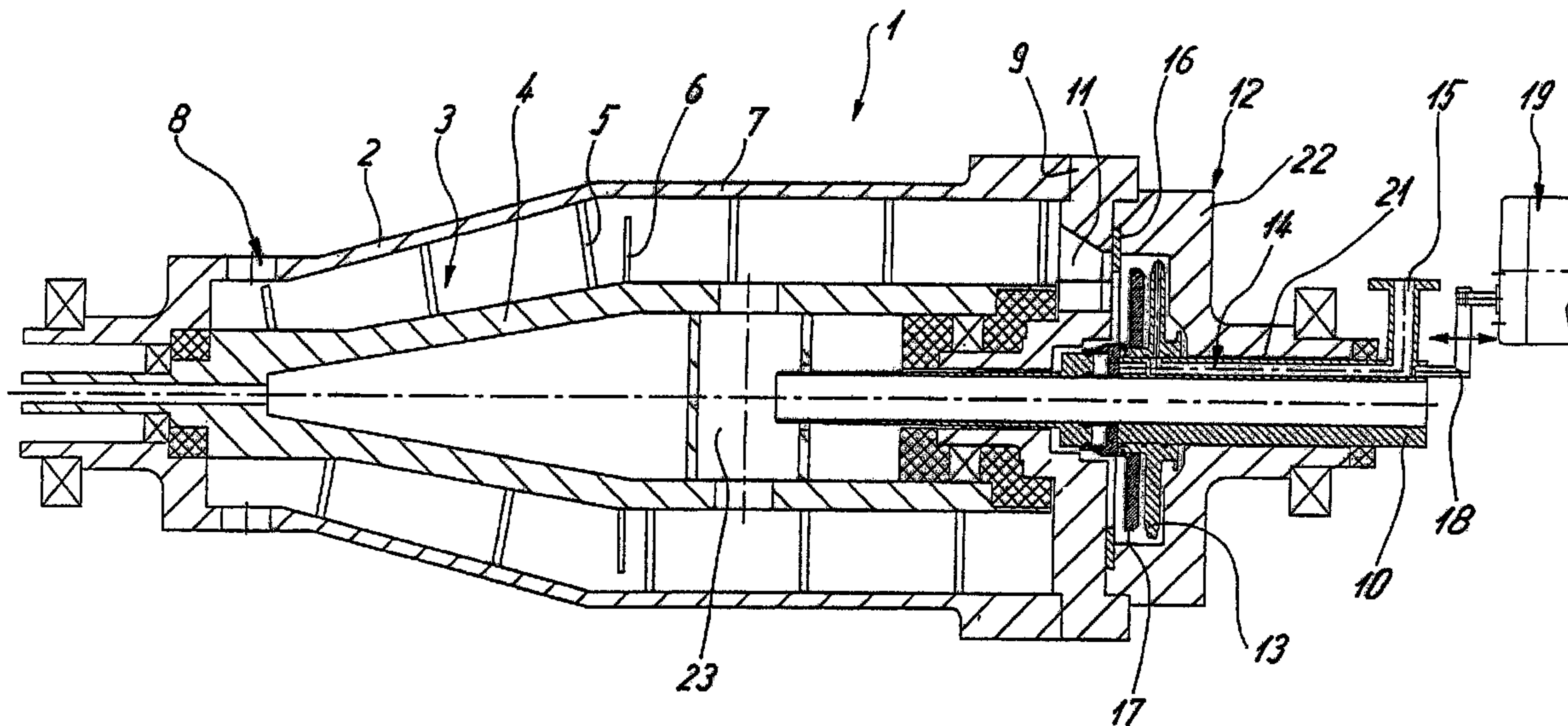

(86) Date de dépôt PCT/PCT Filing Date: 2004/07/30
 (87) Date publication PCT/PCT Publication Date: 2005/02/24
 (85) Entrée phase nationale/National Entry: 2006/02/07
 (86) N° demande PCT/PCT Application No.: EP 2004/008575
 (87) N° publication PCT/PCT Publication No.: 2005/016544
 (30) Priorité/Priority: 2003/08/08 (DE103 36 350.5)

(51) Cl.Int./Int.Cl. *B04B 1/20* (2006.01),
B04B 11/06 (2006.01), *B04B 1/00* (2006.01)
 (71) Demandeur/Applicant:
WESTFALIA SEPARATOR AG, DE
 (72) Inventeurs/Inventors:
REICHENBACH, MICHAEL, DE;
MUELLER, MICHAEL, DE
 (74) Agent: FETHERSTONHAUGH & CO.

(54) Titre : CENTRIFUGEUSE A VIS A PAROI PLEINE COMPRENANT UNE POMPE CENTRIPETE
 (54) Title: SOLID BOWL SCREW CENTRIFUGE COMPRISING A CENTRIPETAL PUMP



(57) Abrégé/Abstract:

The invention relates to a solid bowl screw centrifuge comprising a rotating drum (2) which comprises at least one scraping blade for removing a liquid phase. The inventive centrifuge is characterized in that an adjustable throttle device is mounted upstream of the scraping blade.

(12) NACH DEM VERTRAG ÜBER DIE INTERNATIONALE ZUSAMMENARBEIT AUF DEM GEBIET DES PATENTWESENS (PCT) VERÖFFENTLICHTE INTERNATIONALE ANMELDUNG

(19) Weltorganisation für geistiges Eigentum
Internationales Büro(43) Internationales Veröffentlichungsdatum
24. Februar 2005 (24.02.2005)

PCT

(10) Internationale Veröffentlichungsnummer
WO 2005/016544 A1

- (51) Internationale Patentklassifikation⁷: **B04B 1/20**, (74) **Anwalt: SPECHT, Peter**; Jöllenbecker Strasse 164, 33613 Bielefeld (DE).
- (21) Internationales Aktenzeichen: PCT/EP2004/008575 (81) **Bestimmungsstaaten** (soweit nicht anders angegeben, für jede verfügbare nationale Schutzrechtsart): AE, AG, AL, AM, AT, AU, AZ, BA, BB, BG, BR, BW, BY, BZ, CA, CH, CN, CO, CR, CU, CZ, DE, DK, DM, DZ, EC, EE, EG, ES, FI, GB, GD, GE, GH, GM, HR, HU, ID, IL, IN, IS, JP, KE, KG, KP, KR, KZ, LC, LK, LR, LS, LT, LU, LV, MA, MD, MG, MK, MN, MW, MX, MZ, NA, NI, NO, NZ, OM, PG, PH, PL, PT, RO, RU, SC, SD, SE, SG, SK, SL, SY, TJ, TM, TN, TR, TT, TZ, UA, UG, US, UZ, VC, VN, YU, ZA, ZM, ZW.
- (22) Internationales Anmeldedatum: 30. Juli 2004 (30.07.2004)
- (25) Einreichungssprache: Deutsch
- (26) Veröffentlichungssprache: Deutsch
- (30) Angaben zur Priorität: 103 36 350.5 8. August 2003 (08.08.2003) DE
- (71) **Anmelder** (für alle Bestimmungsstaaten mit Ausnahme von US): **WESTFALIA SEPARATOR AG** [DE/DE]; Werner-Habig-Strasse 1, 59302 Oelde (DE).
- (72) **Erfinder; und**
- (75) **Erfinder/Anmelder** (nur für US): **REICHENBACH, Michael** [DE/DE]; Krefelderstrasse 26, 50670 Köln (DE). **MÜLLER, Michael** [DE/DE]; Menzelstrasse 2, 46539 Dinslaken (DE).
- (84) **Bestimmungsstaaten** (soweit nicht anders angegeben, für jede verfügbare regionale Schutzrechtsart): ARIPO (BW, GH, GM, KE, LS, MW, MZ, NA, SD, SL, SZ, TZ, UG, ZM, ZW), eurasisches (AM, AZ, BY, KG, KZ, MD, RU, TJ, TM), europäisches (AT, BE, BG, CH, CY, CZ, DE, DK, EE, ES, FI, FR, GB, GR, HU, IE, IT, LU, MC, NL, PL, PT, RO, SE, SI, SK, TR), OAPI (BF, BJ, CF, CG, CI, CM, GA, GN, GQ, GW, ML, MR, NE, SN, TD, TG).

[Fortsetzung auf der nächsten Seite]

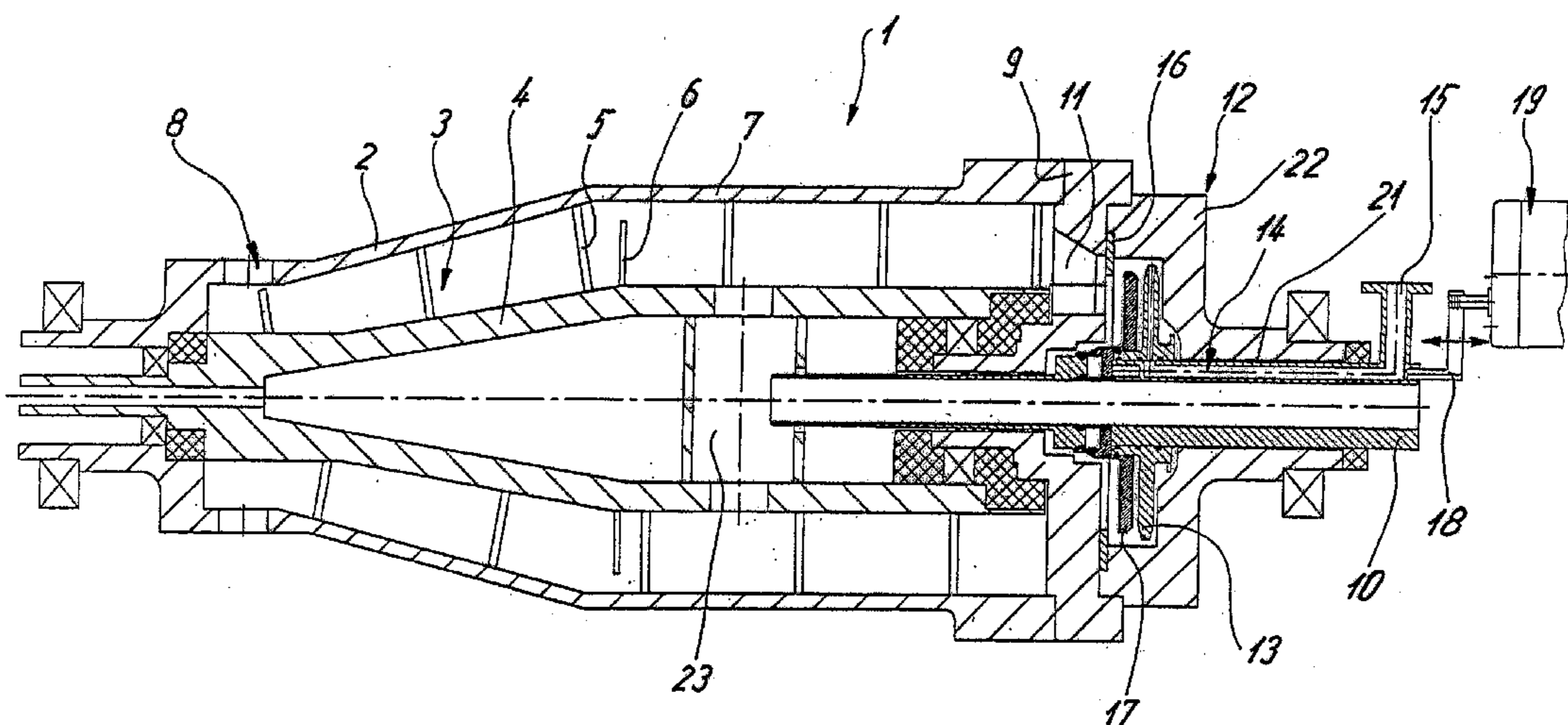
(54) **Title:** SOLID BOWL SCREW CENTRIFUGE COMPRISING A SCRAPING BLADE(54) **Bezeichnung:** VOLLMANTEL-SCHNECKENZENTRIFUGE MIT SCHÄLSCHEIBE(57) **Abstract:** The invention relates to a solid bowl screw centrifuge comprising a rotating drum (2) which comprises at least one scraping blade for removing a liquid phase. The inventive centrifuge is characterized in that an adjustable throttle device is mounted upstream of the scraping blade.(57) **Zusammenfassung:** Eine Vollmantel-Schneckenzenrifuge mit einer drehbaren Trommel (2), die zur Ableitung einer Flüssigkeitsphase wenigstens eine Schälscheibe aufweist, zeichnet sich dadurch aus, dass der Schälscheibe eine verstellbare Drosseleinrichtung vor geschaltet ist.

WO 2005/016544 A1

WO 2005/016544 A1



Veröffentlicht:

— *mit internationalem Recherchenbericht*

Zur Erklärung der Zweibuchstaben-Codes und der anderen Abkürzungen wird auf die Erklärungen ("Guidance Notes on Codes and Abbreviations") am Anfang jeder regulären Ausgabe der PCT-Gazette verwiesen.

WO 2005/016544

PCT/EP2004/008575

SOLID BOWL SCREW CENTRIFUGE COMPRISING A SCRAPING
BLADE

5

The invention relates to a solid bowl screw centrifuge according to the preamble of Claim 1.

Centrifuges having one or more centripetal pump(s) as
10 a liquid discharge are known from the field of separators as well as from the field of solid bowl screw centrifuges.

It is also known to discharge a liquid phase, particularly under pressure, from solid bowl screw
15 centrifuges by means of centripetal pumps. In these cases, a baffle plate is generally arranged on the screw in the transition to the conical area or at another suitable point. For adjusting the conditions in the centrifuge, particularly the liquid level, the centripetal pump is
20 appropriately throttled. This has considerable effects on the entire process; thus, on the centrifuge as well as possible surrounding components or components on the output side. The adjusting of solid bowl screw centrifuges therefore requires relatively high expenditures and can
25 only take place to a limited extent during the operation.

It is therefore an object of the invention to improve

the operation and particularly the adjustability of solid bowl screw centrifuges which have a centripetal pump as the liquid discharge.

5 The invention achieves this task by means of the object of Claim 1.

 Accordingly, in the case of the solid bowl screw centrifuge of the above-mentioned type, a throttling device
10 which, preferably in the operation during rotations of the drum, is, in particular, continuously adjustable, is connected in front of the centripetal pump in the centripetal chamber section, the throttling device being assigned to or connected behind the discharge openings
15 which additionally may be equipped with an overflow disk. This throttling device makes it possible to influence the liquid level in the drum of the centrifuge in addition to the operation of the baffle plate by throttling the liquid outlet cross-section and thus by changing the flow
20 resistance between the overflows from the drum and the throttling device in front of the centripetal pump or the gripper, which surprisingly clearly optimizes the possibility of controlling and/or regulating the conditions in the centrifuge.

25

 When centripetal pumps are used, which per se already permit a certain control of the liquid level in the

centrifuge, an additional throttling device in front of the centripetal pump so far had not been considered, although, as recognized by the invention, this additional throttling device results in special advantages when controlling
5 and/or regulating the liquid level in the drum.

According to a particularly advantageous and cost-effective variant, the throttling device may be constructed as an element which is stationary during the operation.
10 However, as an alternative, it may be constructed as an element which rotates during the operation - particularly together with the drum.

According to a variant, the throttling device has at
15 least one or more movable disk elements, slide elements and/or pneumatically or hydraulically operable bellows or membrane elements which preferably is/are assigned to the individual discharge openings and can more or less open up or close the latter.

20

In this case, the throttling device is preferably constructed as a movable throttle disk arranged in the centripetal chamber section and situated behind the discharge openings and in front of the centripetal pump.
25 Particularly preferably, a baffle plate is also arranged on the screw.

From German Patent Document DE 39 21 327 A1, it is known to form a weir of adjusting elements, such as pressure bellows and the like. A throttling device could also be implemented with such pressure bellows. However, 5 the constructively simple and easily adjustable throttle disk is preferable in this case, particularly in a further development in which it does not co-rotate.

Particularly when using solid bowl screw centrifuges 10 having a centripetal pump, it is particularly advantageous to use the additional throttling device for influencing the liquid level in the centrifuge. Although European Patent Document EP 0 702 599 B1 already discloses the assigning of an axially displaceable throttle disk to an overflow-type 15 passage in a drum lid outside a centrifugal drum on the exterior side of the drum, which throttle disk is constructed as a part which is stationary during the operation and is constructed to be axially movable, particularly axially slidable, relative to the overflow 20 weir, by means of the stationary throttle disk, a flow resistance is generated in the weir which is the greater, the smaller the axial distance between the weir and the throttle disk. As the flow resistance increases, a higher liquid pressure is required at the passage, which results 25 in a rise of the liquid level in the centrifugal drum. If the axial distance between the weir and the throttle disk is enlarged, the liquid level in the centrifugal drum will

decrease to a value which is caused essentially only by the passage of the weir or the discharge openings. However, the use of the throttle disk in the case of a centrifuge having a centripetal pump was not considered in this document because centripetal pumps per se already permit a certain regulating of the liquid level in the drum. This regulating takes place by way of the adjusting of a valve in the discharge line, which valve influences the regulating of the liquid level by way of corresponding counterpressure.

It is surprisingly advantageous to combine the centripetal pump with a movable, particularly axially adjustable throttle disk in the drum because it thereby becomes possible, also when a centripetal pump is used, to continuously regulate the pool depth during the operation and thus adjust the optimal ratio between the flow in the centripetal chamber section and the pool depth in the decanter drum without having to the throttle discharge line.

In this case, the throttle disk - even in the non-rotating further development - surprisingly is arranged differently than in the state of the art in the drum in a very different manner than in the case of the throttle disk of European Patent Document EP 0 702 599 B1.

With respect to the state of the art, German Patent Document DE 37 28 901 C1 is also mentioned, in which, in the case of a solid bowl screw centrifuge according to the above-mentioned type, a swirl flow space is constructed in a weir disk, which is arranged at the passage openings, the axis of symmetry of the swirl flow space extending parallel to and at a radial distance from the axis of rotation of the drum, and its feeding pipe having a larger radial distance from the axis of rotation of the centrifuge drum than the discharge duct. In this manner, an operation is achieved at two liquid levels but an adjustability does not exist during the operation.

In the case of pulp which is difficult to discharge, a hydraulic support is often required during the discharge by a Δp in front of and behind a baffle plate on the screw. If the regulating diameter at the liquid discharge is rigidly adjusted to this value, penetrations of liquid can be expected on the solids side during the starting process because no sufficient solids closure has yet formed at the baffle plate. Inversely, the maximal pool depth / clarifying effect cannot be achieved when the adjustment of the regulating diameter is large. By means of the combination of the throttle disk and the centripetal pump, an operation "with a shallow pool" can now take place in a simple manner in the starting condition until a sufficient bed formation or solids closure has taken place at the

baffle plate in order to then increase the pool depth to the maximally possible value. The invention therefore makes it possible to satisfactorily process also pulp by means of a centripetal pump which is difficult to
5 discharge.

For this purpose, the non-rotating centripetal pump is no longer throttled for the adjustment but, after its one-time suitable adjustment, a regulating of the conditions in
10 the drum also becomes possible during the operation.

The preferably non-rotating, axially movable throttle disk in combination with the centripetal pump and a baffle plate on the screw is also advantageous particularly when
15 starting the solid bowl screw centrifuge. Specifically also this advantage was not recognized according to the state of the art.

Furthermore, there is often the requirement that it
20 should be possible to influence the pool depth (or the depth of the liquid level) during the operation in order to be able to compensate fluctuations in the inlet and in the product quality and thereby operate the decanter at the optimal operating point in time (efficiency). In the case
25 of decanters having a centripetal pump, this had previously only be possible by means of throttling the discharge line.

The throttle disk may be constructed as a part which is stationary during the operation or rotates along. For the reasons described in European Patent Document EP 0 702 599 B1, the construction as a stationary part is preferred.

5

The throttle disk can easily be constructed to be stationary during the operation if it can be moved by means of a connecting rod which penetrates a stationary feeding pipe not rotatable during the operation or a component connected with the feeding pipe. In this case, the throttle disk is particularly preferably displaceably guided on the feeding pipe and/or the centripetal pump.

Additional advantageous further developments of the invention are indicated in the remaining subclaims.

In the following, the invention will be explained in detail by means of embodiments with reference to the drawing.

20

Figure 1 is a sectional view of a drum of a solid bowl screw centrifuge according to the invention;

Figure 2a is a sectional view of the solid bowl screw centrifuge in a first operating condition;

25

Figure 2b is a view of an enlargement of a cutout of

Figure 2a;

Figure 3a is a sectional view of the solid bowl screw centrifuge in a second operating condition;

5

Figure 3b is a view of an enlargement of cutout of Figure 3a;

Figure 4 is a sectional view of a drum of a solid bowl screw centrifuge according to the state of the art.

10

Figure 1 is a sectional view of a solid bowl screw centrifuge 1 having a rotatable drum 2 and a rotatable screw 3, the drum 2 and the screw 3 having a differential rotational speed relative to one another during the operation, that is, rotate relative to one another.

15

The screw 3 has an interior screw body 4 as well as an exterior screw blade 5. The screw 3 conically tapers at one of its ends, in the area of the transition to the conical area of the screw 3, a baffle plate 6 being arranged on the latter.

20

The drum 2 has a shell 7, which also tapers conically at one of its ends. At this end of the drum 2, a solids discharge 8 is constructed.

25

At its second end facing away from the tapered end, the drum 2 is axially closed by a drum lid 9. On its interior circumference, the drum lid 9 is penetrated by a feeding pipe 10 for the feeding of the centrifugal material
5 by means of a distributor 23, which will not be explained in detail, into the drum 2. Here, the feeding pipe 10 is stationary relative to the drum 2 in the operation when the drum 2 is rotating.

10 A centripetal chamber section 12 is connected behind the drum lid 9 having overflow-type discharge openings 11 whose inside radius is bounded by a ring disk 16 attached to the lid, which centripetal chamber section 12 is non-rotatably connected with the drum lid 9.

15 The centripetal chamber section 12 consists of a stepped ring attachment 22 which bounds the centripetal chamber section 12 connected behind the drum to the outside, in which a centripetal pump 13 for discharging the
20 liquid phase is connected on the output side. The ring attachment 22 is penetrated by the feeding pipe 10 and by a shaft attachment 21 of the centripetal pump 13, if required, combined with the feeding pipe 10. The centripetal pump 13 is also arranged in a stationary or
25 non-rotatable manner on the feeding pipe 10 and guides liquid through a discharge duct 14 in the shaft attachment 21 of the centripetal pump 13 to an outlet 15.

Between the centripetal pump 13 and the discharge openings or, here, the ring disk 16, a throttle disk 17 is arranged in the centripetal chamber section 12, the outer
5 circumference of the throttle disk 17 preferably being larger than or equal to the inner circumference of the discharge openings.

The throttle disk 17 is axially movably, that is, for
10 example, axially slidably or swivellably, arranged relative to the drum 2, so that its distance from the discharge openings can be completely or partially changed. Here, the throttle disk is slidably arranged on the feeding pipe 10, in which case, it can be moved, for example, by means of at
15 least one connecting rod 18 which penetrates the shaft attachment 21 of the throttle disk 13. For example, an electric drive 19 for moving the one or more connecting rod(s) 18 and thus for displacing the throttle disk 17 is applied to the end of the connecting rod 18 facing away
20 from the throttle disk 17.

The throttle disk 17 - see also Figure 2b - consists of an outer throttle disk section 20, a pipe-type center section 24 and a inner ring section 25 which here is
25 arranged to be axially offset with respect to the throttle disk section 20. The pipe-type section 24 is guided in a sealed-off and displaceable manner on ring attachments 26

of the feeding pipe 10 and a ring attachment 27 of the throttle disk.

By means of the arrangement of Figure 1, it becomes possible to continuously regulate the pool depth (gray) in the drum and to adjust the optimal ratio between the flow into the centripetal chamber section 12 and the pool depth in the drum 2. In this manner, particularly the initially described positive effects can be achieved. In this case, the throttle disk 17 can be moved between the centripetal pump 13 and the discharge openings 11.

On the example of a relatively narrow gap (Figure 2) or a relatively large gap (Figure 3) between the throttle disk 17 and discharge openings 11, Figures 2 and 3 illustrate the effect of the throttle disk 17. In each case, the actual discharge takes place by means of the centripetal pump 13; whereas, by means of the throttle disk 17, the discharge quantity and the pool depth in the drum are regulated. A special advantage is also the combination of the centripetal pump 13, the throttle disk 17 and the baffle plate 6 on the screw which, interacting with the throttle disk, permit a particularly advantageous adjustment of the conditions. Thus, for example, by means of the throttle disk 17, another condition with a so-called shallow pool, that is, with a low pool depth, can be used in the operation until a sufficient bed formation of solids

has taken place in the drum in order to then increase the pool depth to the maximally possible value. Thus, not only the overflow level is adjusted by means of the throttling device but the pool depth is also influenced by throttling
5 the discharge.

Figure 4 shows a solid bowl screw centrifuge according to the state of the art, where no throttle disk 17 is arranged in the centripetal chamber section.

Reference Numbers

	Solid bowl screw centrifuge	1
	drum	2
5	screw	3
	screw body	4
	screw blade	5
	baffle plate	6
	drum shell	7
10	solids discharge	8
	drum lid	9
	feeding pipe	10
	discharge openings	11
	centripetal chamber section	12
15	centripetal pump	13
	discharge duct	14
	outlet	15
	ring disk	16
	throttle disk	17
20	connecting rod	18
	electric drive	19
	throttle disk section	20
	shaft attachment	21
	ring attachment	22
25	distributor	23
	pipe-type section	24
	ring section	25

ring attachment	26
ring attachment	27

WO 2005/016544

PCT/EP2004/008575

CLAIMS:

5 1. Solid bowl screw centrifuge having a screw (3)
which can be rotated at a differential rotational speed
relative to the drum (2), the drum (2) having a solids
discharge (8) at its preferably conical end, and having, at
its end situated opposite the conical end, at least one or
10 more weir-type discharge openings (11) arranged with an
axial drum lid (9), and a centripetal chamber section (12)
being connected behind the drum lid (9) with the discharge
openings (10), in which centripetal chamber section(12) a
centripetal pump (13) is arranged for discharging the
15 liquid phase from the solid bowl screw centrifuge (1),
characterized in that an adjustable throttling device (17)
is connected in front of the centripetal pump (13) in the
centripetal chamber section, the throttling device (17)
being assigned to or connected behind the discharge
20 openings.

2. Solid bowl screw centrifuge according to Claim 1,
characterized in that the throttling device (17) can be
adjusted during the operation as the drum is rotating.

25

3. Solid bowl screw centrifuge according to Claim 1,
characterized in that the throttling device (17) permits a

continuous adjusting of the pool depth.

4. Solid bowl screw centrifuge according to Claim 1,
characterized in that a baffle plate (6) is arranged on the
5 screw (3).

5. Solid bowl screw centrifuge according to one of
Claims 1 to 2,
characterized in that the throttling device (17) is
10 constructed as an element which is stationary during the
operation.

6. Solid bowl screw centrifuge according to one of
Claims 1 to 3,
15 characterized in that the throttling device (17) is
constructed as an element which rotates during the
operation, particularly with the drum (2).

7. Solid bowl screw centrifuge according to Claim 3
20 or 4,
characterized in that the throttling device (17) has at
least one or more movable disk elements, slide elements
and/or pneumatically or hydraulically operable bellows or
membrane elements which are preferably assigned directly to
25 the individual discharge openings.

8. Solid bowl screw centrifuge according to Claim 3

or 4,

characterized in that the throttling device is constructed as a throttle disk (17) arranged in the centripetal chamber section (12), connected behind the discharge openings and
5 connected in front of the centripetal pump (13).

9. Solid bowl screw centrifuge according to Claim 6, characterized in that the throttle disk has an axially movable construction.

10

10. Solid bowl screw centrifuge according to one of the preceding claims, characterized in that the throttle disk (17) has a swivellable construction.

15

11. Solid bowl screw centrifuge according to one of the preceding claims, characterized in that the throttle disk is movable by means of at least one connecting rod (18) which is penetrated by
20 a stationary feeding pipe (10), which is non-rotatable during the operation, or by a component connected with the feeding pipe (10).

12. Solid bowl screw centrifuge according to one of
25 the preceding claims, characterized in that the throttle disk is displaceably guided on the feeding pipe (10) and/or the centripetal pump

(26).

13. Solid bowl screw centrifuge according to one of
the preceding claims,
5 characterized in that the throttle disk (17) can be moved
between the centripetal pump (13) and the discharge
openings (11).

Fig. 2

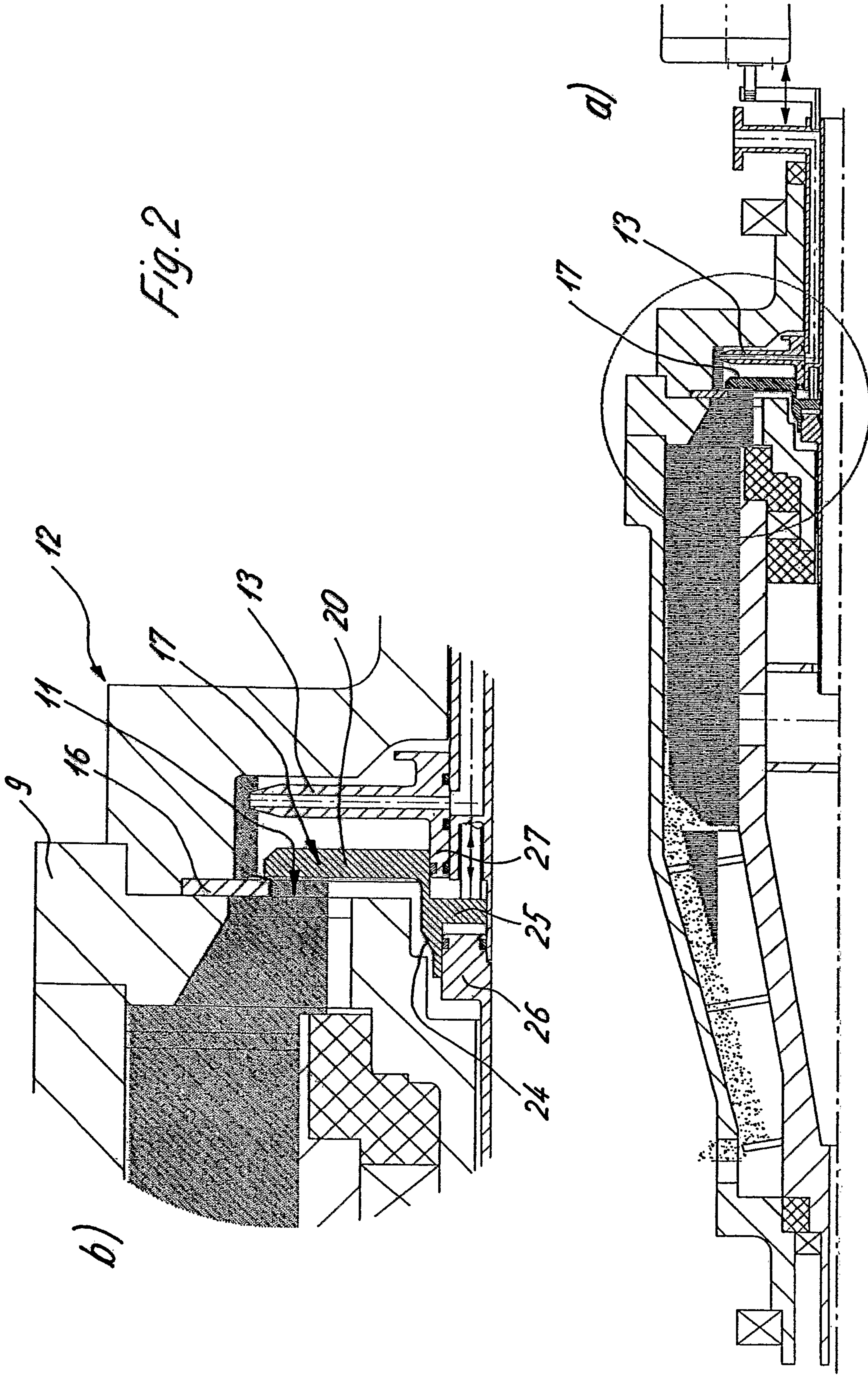
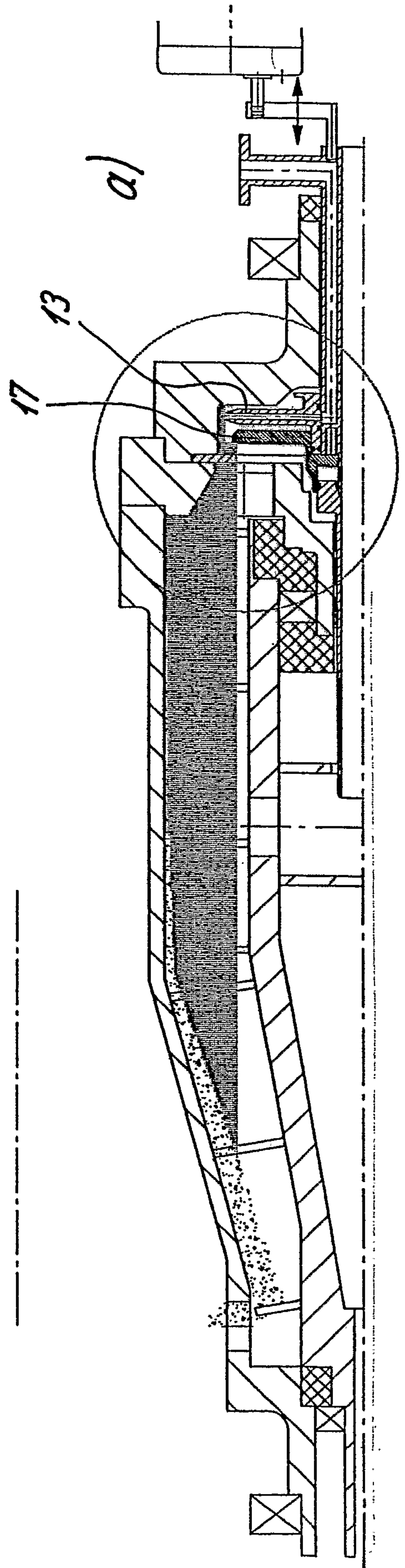
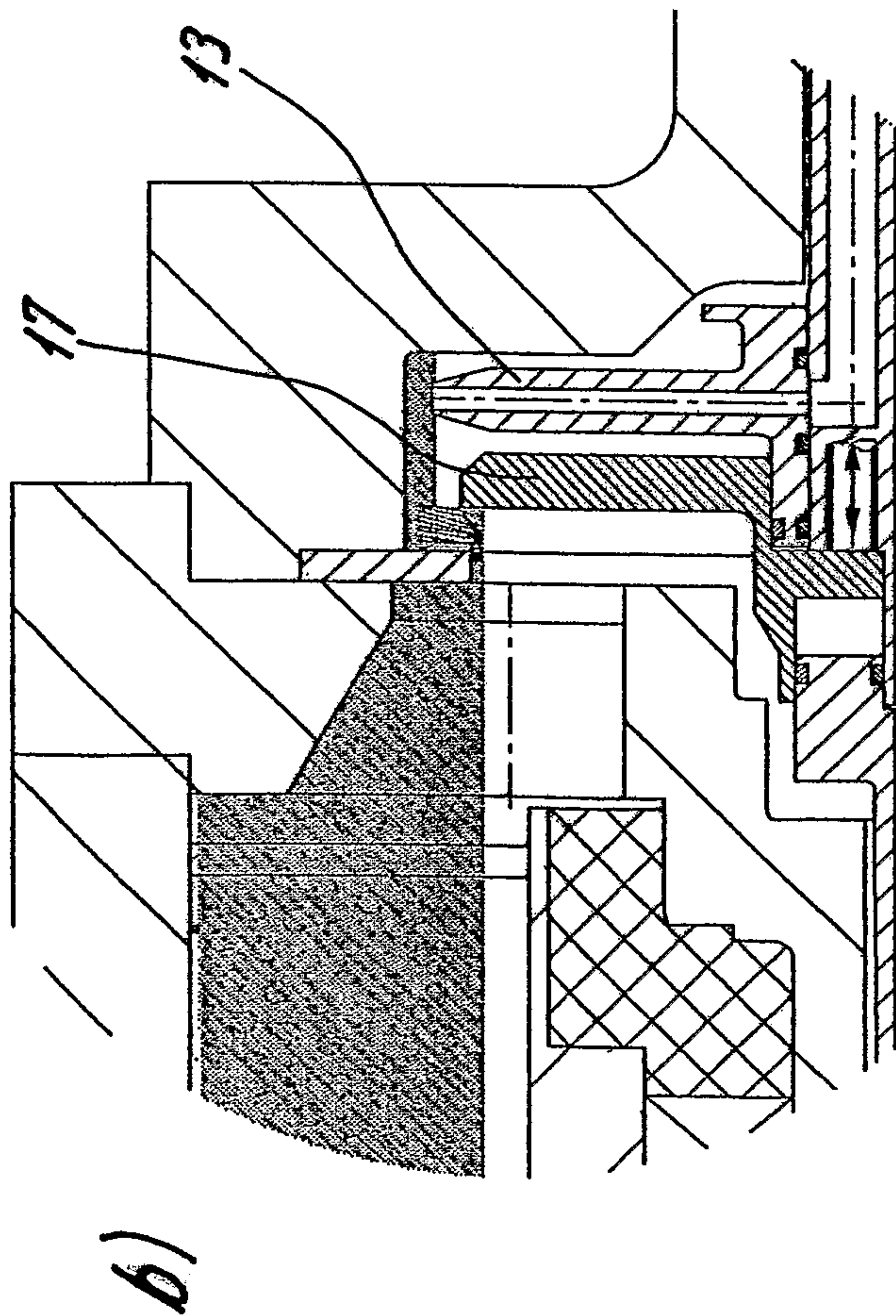

Fig. 3



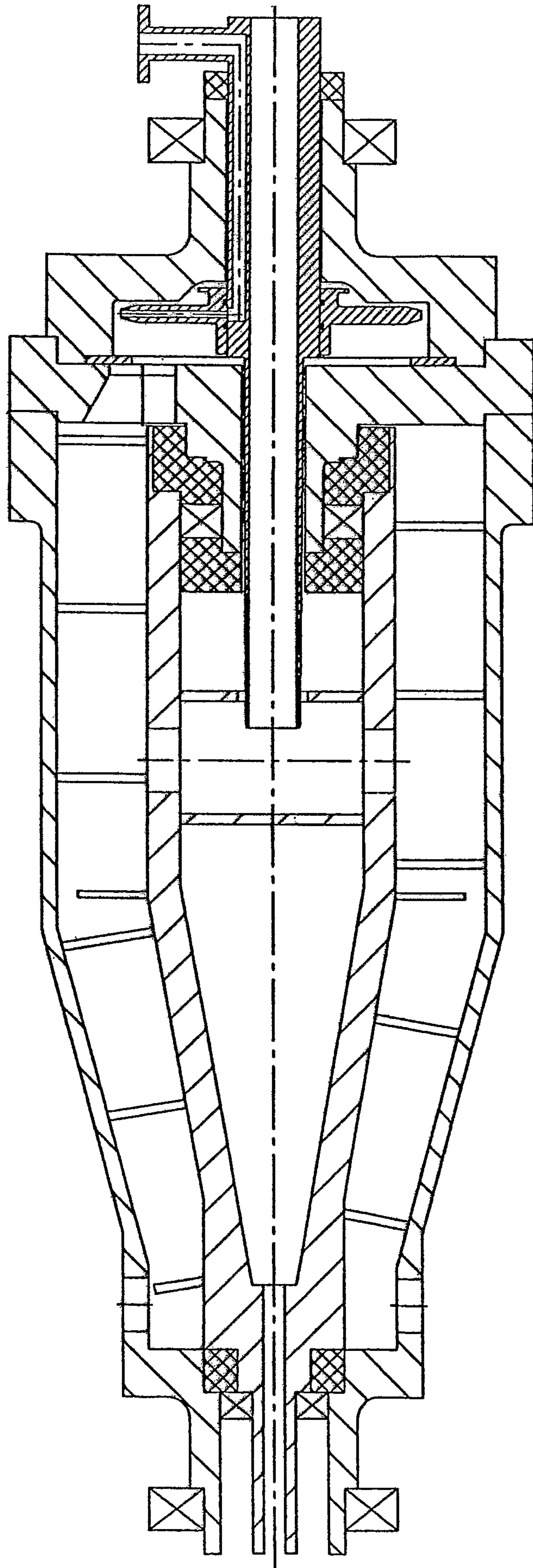

Fig. 4

