

(12) INTERNATIONAL APPLICATION PUBLISHED UNDER THE PATENT COOPERATION TREATY (PCT)

(19) World Intellectual Property
Organization
International Bureau



(43) International Publication Date
22 June 2017 (22.06.2017)

(10) International Publication Number
WO 2017/106565 A1

(51) International Patent Classification:

C08L 23/12 (2006.01) C08L 3/02 (2006.01)
C08L 23/06 (2006.01)

(21) International Application Number:

PCT/US2016/067035

(22) International Filing Date:

15 December 2016 (15.12.2016)

(25) Filing Language:

English

(26) Publication Language:

English

(30) Priority Data:

62/386,895	15 December 2015 (15.12.2015)	US
62/387,102	21 December 2015 (21.12.2015)	US
15/093,187	7 April 2016 (07.04.2016)	US
62/322,844	15 April 2016 (15.04.2016)	US

(72) Inventor; and

(71) Applicant : KOHN, Steve [US/US]; 102 Mohawk Road,
Short Hills, NJ 07078 (US).

(74) Agent: WEISS, Philip, M.; Weiss & Weiss, 410 Jericho
Turnpike, Suite 105, Jericho, NY 11753 (US).

(81) Designated States (unless otherwise indicated, for every
kind of national protection available): AE, AG, AL, AM,

AO, AT, AU, AZ, BA, BB, BG, BH, BN, BR, BW, BY,
BZ, CA, CH, CL, CN, CO, CR, CU, CZ, DE, DJ, DK, DM,
DO, DZ, EC, EE, EG, ES, FI, GB, GD, GE, GH, GM, GT,
HN, HR, HU, ID, IL, IN, IR, IS, JP, KE, KG, KH, KN,
KP, KR, KW, KZ, LA, LC, LK, LR, LS, LU, LY, MA,
MD, ME, MG, MK, MN, MW, MX, MY, MZ, NA, NG,
NI, NO, NZ, OM, PA, PE, PG, PH, PL, PT, QA, RO, RS,
RU, RW, SA, SC, SD, SE, SG, SK, SL, SM, ST, SV, SY,
TH, TJ, TM, TN, TR, TT, TZ, UA, UG, US, UZ, VC, VN,
ZA, ZM, ZW.

(84) Designated States (unless otherwise indicated, for every
kind of regional protection available): ARIPO (BW, GH,
GM, KE, LR, LS, MW, MZ, NA, RW, SD, SL, ST, SZ,
TZ, UG, ZM, ZW), Eurasian (AM, AZ, BY, KG, KZ, RU,
TJ, TM), European (AL, AT, BE, BG, CH, CY, CZ, DE,
DK, EE, ES, FI, FR, GB, GR, HR, HU, IE, IS, IT, LT, LU,
LV, MC, MK, MT, NL, NO, PL, PT, RO, RS, SE, SI, SK,
SM, TR), OAPI (BF, BJ, CF, CG, CI, CM, GA, GN, GQ,
GW, KM, ML, MR, NE, SN, TD, TG).

Published:

— with international search report (Art. 21(3))



WO 2017/106565 A1

(54) Title: PRODUCT AND METHOD FOR A PLASTIC BAG OR PLASTIC COMPOSITION COMPRISING INORGANIC MINERALS

(57) Abstract: Products and methods for producing products which comprise polyethylene and inorganic minerals for a single layer plastic bag or plastic composition.

**PRODUCT AND METHOD FOR A PLASTIC BAG OR PLASTIC COMPOSITION
COMPRISING INORGANIC MINERALS**

Related Applications

The present application is a continuation in part of U.S. patent application Serial No. 15/093,187 filed April 7, 2016 and is related to Provisional application Serial No. 62/322,844 filed April 15, 2016, Provisional application Serial No. 62/386,895 filed December 15, 2015 and Provisional Application Serial No. 62/387,102 filed December 21, 2015.

Field of the Invention

The present invention relates to products and a method of producing products which comprise polyethylene and inorganic minerals for a single layer plastic bag or plastic composition.

Background of the Invention

Printed and unprinted flexible and semi-rigid packaging materials are commonly used for packing retail, industrial, and commercial products into plastic bags such as T-sacks, sacks, pouches, wrappers and the like. Desired product features of plastic bags include printability and different levels of opacity. Since some plastic products may be used in a sterile environment, sterilization may also be a required step in the manufacturing process.

The amount and type of resin used, and the thickness, material weight and density of the packaging materials all affect the cost and other characteristics of the

plastic bags. Key performance attributes of these packaging materials include substantial barrier protection, product protection and containment, shipping, storage, and dispensing applications. Barrier protection refers to the ability of a packaging material to stop or retard the passage of atmospheric gases or water vapor into the material from the outside environment. The prior art uses metalizing to provide a lustrous metallic appearance, that when applied to plastic film, improves gas and light barrier properties of the film.

Polyethylene (PE) film has been used in the prior art on preparation of bags because of its transparency, toughness, heat seal-ability, low water vapor transmission rate, low temperature performance and low cost. PE films are highly permeable to oxygen and other non-polar gases and have high viscoelastic flow properties.

Polypropylene (PP) film is a transparent, tough, thermoplastic film. Un-oriented film is soft and becomes brittle at low temperature, however this property as well as strength, stiffness, and clarity can be improved by orientation e.g. bi-axially oriented polypropylene (BOPP). Polystyrene film is a transparent, stiff film of high permeability and moderate temperature resistance that can be oriented to improve strength. Films can also be made of polyamide (PA). PA is used almost entirely as a film or sheet material in packaging applications. The clear film offers a good oxygen barrier, and is particularly tough and abrasion resistant. However, PA film is a poor moisture barrier, does not heat seal, and has cost disadvantages. Films can also be made of polychlorotrifluoroethylene (PCTFE or CTFE), which is a plastic material characterized by exceptional moisture and good oxygen barrier characteristics as well as good clarity.

A problem that exists with prior films is that these products do not incorporate low cost, environmentally friendly materials and designs. Environmentally friendly materials can have desirable attributes such as biodegradability, compostability, and recyclability, and may also use less energy, pollute less, and generate fewer greenhouse gases in their manufacture than previous materials. Such environmentally friendly materials are increasingly in demand from consumers and retailers.

Another significant problem that exists with prior flexible film packaging is the high concentration of expensive plastic and polymers required to achieve the performance specifications needed. Yet another problem is the very expensive combinations of plastics, foils, coatings, and metalized films to achieve structural, barrier, sealing and printability aspects.

U.S. Patent 8,507,581 relates to a stone based copolymer substrate which includes calcium carbonate from approximately 50-85% by weight varying in size generally from 1.0 to 3.0 microns; HDPE from approximately 2-25% by weight; and a biopolymer from approximately 2-25% by weight. The biopolymer may include a polymer of lactic acid (PLA), polyhydroxybutanoate (PHB), polyhydroxyalkanoates (PHA), Nylon 611 and Polyactic Acid.

U.S. Patent 8,569,411 is directed to flexible packaging composites which include one or more mineral-containing layers with thermoplastic bonding agent. The composite may also contain one or more non-mineral containing layers, including various combinations of extruded resins, cast or blown films, and fibers. The mineral-containing layer is substantially and continuously bonded to the other layers. The polymer, fiber

and mineral containing layers can be made such that the resulting composite structure formed is machined to form a storage article. The specification provides that the bonding agents can include, but are not limited to, HDPE, and another bonding agent that is a high molecular weight high density polyethylene. The film composite comprises: at least one mineral-containing layer containing a thermoplastic bonding agent in an amount of about 15-30% by weight and a mineral material that is present in an amount of about 70-85% by weight. The film composite comprises: at least one mineral-containing layer bonded to said at least one non mineral-containing layer, said at least one mineral-containing layer containing a thermoplastic bonding agent in an amount of about 15-30% by weight and a mineral material that is present in an amount of about 70-85% by weight. The film composite comprises: at least one mineral-containing layer that is at least 0.5 mil in caliper containing a thermoplastic bonding agent in an amount of about 15-30% by weight and a mineral content that is present in an amount of about 70-85% by weight.

U.S. Patent 8,177,066 is directed to a high visual impact plastic packaging, wherein plasticized or laminated paperboard materials can be used, as well as plastic materials such as mineral-based materials, poly lactic acid, and recycled or recyclable polyurethane. The packaging is created into separate portions that include blister portions, cavity portions, windows and holes, and compacted regions.

U.S. Patent 9,062,190 is directed to a stone based copolymer substrate which includes calcium carbonate from approximately 50-85% by weight and varying in size

generally from 1.0 to 3.0 microns; HDPE from approximately 2-25% by weight; and a biopolymer from approximately 2-25% by weight.

U.S. Patent Publication 2013/0227881 is directed to a recycled plastic composite composition which includes a recycled EVA 30% to 80% by weight and a stone powder from 20% to 70% by weight.

U.S. Patent Publication 2009/0047499 is directed to a multi-layer composite structure and storage article made therefrom, which includes a fiber-containing layer, such as a fiberboard layer or other layer having fibers from natural or synthetic sources, and a ground calcium carbonate-containing layer covering the fiber-containing layer. The extruded calcium carbonate containing layer comprising at least 30% by weight of the thermoplastic bonding agent.

U.S. Patent Publication 2009/0047511 is directed to a multi-layer composite material structure and storage article made therefrom which includes a fiber-containing layer, such as fiberboard layer or other layer having fibers from natural or synthetic sources, and a mineral-containing layer covering the fiber-containing layer.

U.S. Patent Publication 2009/0142528 is directed to a composite structure having at least two layers, comprising less than 25% Polymers, a fiber-containing layer, such as a layer of paperboard or other layer having fibers from natural or synthetic sources, and a mineral-containing layer covering and bonded to the fiber-containing layer.

U.S. Patent Publication 2014/0057061 is directed to flexible packaging composites having at least two layers which include one or more mineral-containing layers with a thermoplastic bonding agent. A flexible film composite suitable for use as

a packaging material for storage of articles, comprising: at least one mineral-containing layer containing a thermoplastic bonding agent and a mineral material. The mineral containing layer is an external most layer of the flexible film composite. The mineral material is selected from the group consisting of ground calcium carbonate, diatomaceous earth, mica, silica, glass, zeolite, slate, and combinations thereof, and at least one layer adhered to the at least one mineral-containing layer by a wet or dry lamination technique. The mineral-containing layer and the at least one other layer form a composite material that is flexible. The mineral material is present in the mineral-containing layer in an amount of up to 85% by weight. The at least one other layer comprises a non-mineral containing layer selected from the group consisting of ink, nylon, a sealant, foil, oriented polypropylene (OPP), metalized oriented polypropylene (OPP), polypropylene, polypropylene terephthalate (PET), a peel and stick label backing, polyethylene, ethylene-vinyl alcohol (EVOH), paper, a fiber material coated with polyethylene, a fiber containing layer, a biodegradable polymer, a photodegradable polymer, and a polyester. The at least one mineral containing layer is sterilizable.

U.S. Patent Publication 2014/0272352 is directed to a composite structure which includes at least one or more fiber-containing layers and one or more mineral-containing layers. The mineral-containing layer comprises a thermoplastic bonding agent fixing the minerals in place. A recyclable composite packaging material, comprising: a fiber-containing layer, and a mineral-containing layer bonded to the fiber-containing layer. The mineral-containing layer comprises a thermoplastic bonding agent

and has a mineral content of 20-70 wt%; and wherein thickness and composition of the mineral containing layer are selected to provide a screen cleanliness efficiency of 60% to 100% and a removal efficiency of the mineral containing layer from the fiber-containing layer of 50% to 95% by mass in a repulping recycling operation.

U.S. Patent Publication 2014/0274632 is directed to a composite structure including a fiber-containing layer, such as a fiberboard layer or other layer having fibers from natural and/or synthetic sources, and a mineral-containing layer covering the fiber-containing layer. A composite packaging material, comprising: one or more mineral-containing layer extrusion bonded to a fiber-containing layer; wherein the mineral-containing layer is formed from a mineral containing polymer comprising a polymer composition and a mineral composition.

U.S. Patent Publication 2014/0274633 is directed to a composite structure having at least two layers, including a fiber-containing layer, such as a fiberboard layer or other layer having fibers from natural and/or synthetic sources, and a mineral-containing layer covering the fiber-containing layer.

Summary of Invention

The present invention relates to the use of a plastic material in combination with environmentally stable materials. The environmentally stable materials are inorganic mineral compounds.

It is an object of the present invention for the inorganic mineral compound to be a calcium carbonate based material.

The present invention relates to a plastic composition or plastic bag comprising: approximately 20-49% calcium carbonate; approximately 30-60% high density polyethylene; approximately 0-20% linear low density polyethylene; and approximately 0-10% fillers/bonding agent. The plastic composition or plastic bag is a single layer. It is an object of the present invention for the plastic composition or plastic bag to further comprise a biopolymer. It is an object of the present invention for the biopolymer to comprise approximately 0.5% to 20% by weight of the plastic composition or plastic bag. It is an object of the present invention for the plastic composition or plastic bag to further comprise a biopolymer in an amount less than 1.5%. It is an object of the present invention for the biopolymer to be selected from the group consisting of: poly lactic acid, poly-hydroxybutanoate, poly-hydroxyalkanoate, Nylon 610, Nylon 611.

It is an object of the present invention for the plastic composition or bag to contain no fibers. It is an object of the present invention for the external surface of the plastic composition or plastic bag to comprise a printable surface. It is an object of the present invention for the external surface of the plastic composition or plastic bag to comprise a smooth surface. It is an object of the present invention for the plastic composition or plastic bag to provide a moisture barrier.

It is an object for the present invention for the plastic composition or plastic bag to comprise printed information. It is an object of the present invention for the plastic composition or plastic bag to comprise a barcode. It is an object of the present invention for the plastic composition or plastic bag to comprise a coupon.

The present invention relates to a plastic composition or plastic bag comprising: approximately 20-49% mineral material; approximately 30-60% high density polyethylene; approximately 0-20% linear low density polyethylene; approximately 0-10% fillers/bonding agents. The plastic composition or plastic bag is a single layer.

It is an object of the present invention for the inorganic mineral compounds to comprise calcium carbonate, calcium sulfate, barium sulfate, kaolin, mica, zinc oxide, dolomite, glass fiber, hollow glass microbead, silica, chalk, talc, pigment, titanium dioxide, bentonite, clay, zeolite, slate, diatomaceous earth and combinations thereof.

It is an object of the present invention for the bags to be a T-sack or T-shirt bag. It is an object of the present invention for the plastic bag to be a die-cut bag, loop-handle bag, tri-fold bag, soft loop flat bag, wave style bag, drawstring bag or drawstring cord bag.

The present invention relates to a plastic composition or plastic bag comprising: approximately 25-40% calcium carbonate; approximately 30-50% high density polyethylene; approximately 5-15% linear low density polyethylene; and approximately 2-7% filler/bonding agent. The plastic composition or plastic bag is a single layer.

The present invention relates to a plastic composition or plastic bag comprising: approximately 20-49% mineral material; approximately 30-60% high density polyethylene; approximately 0-20% low density polyethylene, linear low density polyethylene or a combination thereof; and approximately 0-10% fillers/bonding agent. The plastic composition or plastic bag is a single layer.

The present invention relates to a plastic composition or plastic bag comprising: calcium carbonate, high density polyethylene, linear low density polyethylene, and a filler/bonding agent. The plastic composition or plastic bag is a single layer. It is an object of the present invention for the calcium carbonate to comprise less than 50% by weight of the composition or bag.

The present invention relates to a plastic composition or plastic bag comprising: calcium carbonate, high density polyethylene; low density polyethylene, linear low density polyethylene or a combination; and a filler/bonding agent. The plastic composition or plastic bag is a single layer. It is an object of the present invention for the calcium carbonate to comprise less than 50% by weight of the composition or bag.

It is an object of the present invention for the calcium carbonate based material to be combined with a non-toxic PE resin. It is an object of the present invention for the polyethylene to comprise high density polyethylene, medium density polyethylene, low density polyethylene, linear low density polyethylene or any combination thereof.

It is an object of the present invention that the single layered products be used for packaging, retail, industrial, and commercial products into plastic bags, sacks, pouches, wrappers, and the like. It is an object of the present invention for the packaging and bags to have printing.

It is an object of the present invention for the formed materials to have a high degree of pliability and flexibility, and to have a printing surface that readily accepts coating and inks. It is an object of the present invention to use these materials to form

printed or unprinted plastic compositions or plastic bags. It is an object of the present invention for any of these products to have an antimicrobial component added to it.

It is an object of the present invention for the material to be torn or cut easily so that, for example, a printed coupon can be removed from the material, but strong enough to hold items in the composition or bag.

It is an object of the present invention to use these materials to form plastic T-sacks or T-shirt bags. It is an object of the present invention for the composition or bag to have a matte and a non-glossy finish. It is an object of the present invention for the plastic composition or plastic bags to be smooth to the touch but not slippery. It is an object of the present invention for the plastic composition or plastic bag to be translucent.

It is an object of the present invention to make the environmental friendly plastic materials into different sizes of T-sacks.

It is an object of the present invention for the T-sacks to be made of either HDPE, LLDPE, or LDPE in combination with an inorganic mineral compound. It is an object of the present invention for handles to be either traditional or wave style or die cut.

It is an object of the present invention for the printed or unprinted T-sacks to have dimensions from approximately 5-20" wide by approximately 10"-40" high with approximately a 2"-15" gusset, with thickness ranging from approximately 0.25-4.0 mil.

It is an object of the present invention that the more calcium carbonate based or inorganic material used in the manufacturing of any of the plastic based products, the

greater the required mil thickness of the plastic based product in order to preserve the strength, performance and effectiveness of the plastic based product.

It is an object of the present invention for the printed or unprinted Small T-sack to be approximately 5-8" wide x 10-17" high with a 2-5" gusset. It is an object of the present invention for the T-sack to have a thickness of approximately 0.25 to 4.0 mil.

It is an object of the present invention for the printed or unprinted Medium T-sack to measure approximately 8-11" wide x 16-20" high with a 4-7" gusset. It is an object of the present invention for the T-sack to have a thickness of approximately 0.35 to 4.0 mil.

It is an object of the present invention for the printed or unprinted Large T-sack to measure approximately 11-14" wide x 20-25" high with a 6-9" gusset. It is an object of the present invention for the T-sack to have a thickness of approximately 0.35 to 4.0 mil.

It is an object of the present invention for the printed or unprinted Jumbo T-sack to measure approximately 15-20" wide x 25-40" high with a 7-15" gusset. It is an object of the present invention for the T-sack to have a thickness of approximately 0.35 to 4.0 mil.

It is an object of the present invention for the plastic composition to be formed into a bag. It is an object of the present invention for the plastic composition to be formed into a cover. It is an object of the present invention for the plastic composition to be formed into a sheet. It is an object of the present invention for the plastic composition to be formed into protective garments. It is an object of the present

invention for the plastic composition to be formed into school, office and warehousing supplies. It is an object of the present invention for the plastic composition to be wound on a roll. It is an object of the present invention for the plastic composition to be perforated.

It is an object of the present invention to use the composition to form printed or unprinted storage bags. It is an object of the present invention to use the composition to form bags to store food. It is an object of the present invention to use the composition to form bags to store mattresses. It is an object of the present invention to use the composition to form bags to store furniture or other large objects. It is an object of the present invention to use the composition to form bags to store newspapers, magazines and umbrellas. It is an object of the present invention for any of these products to have an antimicrobial component added to it.

It is an object of the present invention for the covers to include such products as chair, sofa, and love seat covers (collectively known as "upholstery covers"). It is an object of the present invention for the covers to include such products as tarps and/or pallet covers. It is an object of the present invention for any of these products to have an antimicrobial component added to it.

It is an object of the present invention for the sheets to include such products as medical examination paper (also known as table paper) and bedding sheets. It is an object of the present invention to use the composition to form soil liners for use by farmers, landscapers, construction workers and both professional and recreational

gardeners. It is an object of the present invention for any of these products to have an antimicrobial component added to it.

It is an object of the present invention for the protective garments to include medical products such as adult bibs, capes, exam vests, cover ups, drapes, exam shorts, gowns, pillow cases, ponchos, scrubs, lab coats, and protective head coverings. It is an object of the present invention for any of these products to have an antimicrobial component added to it.

It is an object of the present invention for the plastic composition to be sterilized for use in the medical field, such as medical examination paper.

It is an object of the present invention for the plastic composition to be formed into school, office and warehousing supplies. It is an object of the present invention for the plastic composition to be used to produce a bubble mailer product. It is an object of the present invention to use the composition to form shipping mailing labels with adhesive backing. It is an object of the present invention to use the plastic composition to form packing list plastic envelopes typically used on shipping boxes.

It is an object of the present invention to make the environmentally friendly plastic compositions into different sizes of bags, covers, sheets, protective garments, and school, office and warehousing supplies.

It is an object of the present invention for the plastic composition to form signs.

It is an object of the present invention for the bags, covers, sheets, protective garments, and school, office and warehousing supplies to be made from HDPE, LLDPE, or LDPE in combination with inorganic mineral compounds.

It is an object of the present invention for the materials to be destroyed eventually by exposure to the sun. It is an object of the present invention for the plastic bag or plastic composition having the inorganic mineral material to be more biodegradable as more inorganic mineral material is added.

It is an object of the present invention for the inorganic mineral material to be biodegradable and/or compostable. It is an object of the present invention for the plastic composition or plastic bags to be biodegradable. It is an object of the present invention for the plastic composition or plastic bags to be compostable. It is an object of the present invention for the plastic composition or plastic bags to further comprise a biopolymer. It is an object of the present invention for the biopolymer to comprise poly lactic acid, poly-hydroxybutanoate, poly-hydroxyalkanoates, Nylon 610, or Nylon 611. It is an object of the present invention for the biopolymer to comprise approximately 0.5% to 20% by weight of the plastic composition or plastic bag. It is an object of the present invention for the biopolymer to comprise no more than 1.5% of the plastic composition or plastic bag.

It is an object of the present invention for the filler/bonding agent to comprise a polymer.

It is an object of the present invention for the bonding agent to be photodegradable.

It is an object of the present invention for the composition to comprise at least 30% by weight of inorganic mineral powders. It is an object of the present invention for the rest of the material to comprise polyethylene and fillers, with the majority being

polyethylene and less than 5% being fillers. It is an object of the present invention for the composition when used as a plastic material to have the same or equivalent strength as plastic without the inorganic mineral powder, for example, for the plastic materials to have the same or equivalent puncture resistance, tear strength and tensile factor.

The present invention also relates to a plastic packaging composite comprising an inorganic mineral with a bonding agent. It is an object of the present invention for the flexible packaging to be formed into storage bags, protective films, tapes, medical exam paper and other products defined in the present application.

It is an object of the present invention for the plastic composition to have a high degree of pliability and flexibility, and to have a printing surface that readily accepts coating and inks.

It is an object of the present invention for the plastic composition to comprise: nylon, a sealant, oriented polypropylene (OPP), metalized oriented polypropylene, polypropylene, polyethylene terephthalate (PET), polyethylene, ethylene-vinyl alcohol (EVOH).

It is an object of the present invention for the composition to be recyclable.

It is an object of the present invention for the mineral based composition to be biodegradable, photo-degradable, and compostable. It is an object of the present invention for the bonding agent to be photo-degradable.

It is an object of the present invention for the bonding layer to have barrier properties.

It is an object of the present invention for the ground calcium carbonate or other mineral content materials be fabricated from natural sources, such as limestone.

It is an object of the present invention for the single layer mineral containing plastic composition to not include a separate paper layer or a separate plastic layer.

It is an object of the present invention for the composition to be able to be torn for certain uses, for example, medical exam paper, and stretch film. Further, it is an object of the present invention for the composition to be torn or cut such as if a coupon is printed on the material and needs to be torn off.

It is an object of the present invention for the plastic composition to be used to produce mattress bags. It is an object of the present invention for the mattress bags to comprise a thickness of approximately 1.0 to 6 mil. It is an object of the present invention for the mattress bags to have dimensions of 39"-91" by 87"-100" with a gusset of 10"-14". It is an object of the present invention for the mattress bags to comprise a clear polyethylene material. It is an object of the present invention for the material to be water resistant. It is an object of the present invention for the mattress bags to each be individually folded and bagged. It is an object of the present invention for the mattress bags to be on rolls.

It is an object of the present invention for the plastic composition to be used to produce upholstery covers. It is an object of the present invention for the upholstery covers to comprise a thickness of approximately 1.0 to 6.0 mil. It is an object of the present invention for the upholstery covers to have dimensions of 54"-150" by 42"-52". It is an object of the present invention for the upholstery covers to comprise a clear

polyethylene material. It is an object of the present invention for the upholstery covers to comprise an opaque polyethylene material. It is an object of the present invention for the upholstery covers to each be individually folded and bagged. It is an object of the present invention for the upholstery covers to be on rolls.

It is an object of the present invention for the plastic composition to be used to produce a stretch wrap product. It is an object of the present invention for the plastic composition to be approximately a 12 micron/80 gauge equivalent film. It is an object of the present invention for the plastic composition to be placed and dispensed from rolls. It is an object of the present invention for the film to only stick to itself. It is an object of the present invention for the film to tear with the appropriate amount of tension.

It is an object of the present invention for the plastic composition to be used to create a plastic film used for carpet protection. It is an object of the present invention for the film to be stored and distributed off of a roll.

It is an object of the present invention for the plastic composition to be used as a rug storage bag.

It is an object of the present invention for the plastic composition to be used as a plastic portfolio bag. It is an object of the present invention for the plastic portfolio bag to be folded. It is an object of the present invention for the plastic portfolio bag to be stored and distributed off of a roll.

It is an object of the present invention to use the plastic composition for a silverware storage and transport bag.

It is an object of the present invention to use the plastic composition for a cushion storage and transport bag.

Brief Description of Drawings

Figure 1 is an embodiment of a T-sack of the present invention.

Figure 2 is an embodiment of a T-sack of the present invention.

Figure 3 is an embodiment of a T-sack of the present invention.

Figure 4 is an embodiment of a T-sack of the present invention.

Figure 5 is an embodiment of a die cut bag of the present invention.

Figure 6 is an embodiment of a drawstring bag of the present invention.

Figure 7 is an embodiment of a loop handle bag of the present invention.

Figure 8 is an embodiment of a wave style bag of the present invention.

Figure 9 is an embodiment of a drawstring bag of the present invention.

Figure 10 is a front view of an embodiment of a T-sack of the present invention.

Figure 11 is a front view of an embodiment of a die cut bag of the present invention.

Figure 11A is an embodiment of the bag of the present invention showing a food storage bag.

Figure 11B is an embodiment of the bag of the present invention showing an empty food storage bag.

Figure 12A is an embodiment of the bag of the present invention showing a newspaper bag.

Figure 12B is an embodiment of the bag of the present invention showing an empty newspaper bag.

Figure 13 is an embodiment of the present invention showing a tarp cover.

Figure 14 is an embodiment of the present invention showing a pallet cover.

Figure 15A is an embodiment of the present invention showing a mattress in a mattress bag.

Figure 15B is an embodiment of the present invention showing an empty mattress bag.

Figure 16A is an embodiment of the present invention showing a furniture cover over a sofa.

Figure 16B is an embodiment of the present invention showing a furniture cover.

Figure 17 is an embodiment of the present invention showing an examination or medical gown.

Figure 18 is an embodiment of the present invention showing a lab coat.

Figure 19 is an embodiment of the present invention showing an examination or medical cape.

Figure 20 is an embodiment of the present invention showing examination shorts.

Figure 21 is an embodiment of the present invention showing a poncho.

Figure 22 is an embodiment of the present invention showing examination paper.

Figure 23A is an embodiment of the present invention showing a drape.

Figure 23B is an embodiment of the present invention showing a folded drape.

Figure 24A is an embodiment of the present invention showing a packing list in a plastic envelope attached to a box.

Figure 24B is an embodiment of the present invention showing the plastic packing list envelope.

Figure 25A is an embodiment of the present invention showing an umbrella bag with an umbrella.

Figure 25B is an embodiment of the present invention showing an empty umbrella bag.

Figure 26 is an embodiment of the present invention showing a soil liner in a flower bed or in a garden.

Detailed Description of the Invention

Figures 1-4 show embodiments of T-sacks 10-40 of different sizes.

Figure 5 shows a die cut bag 50.

Figure 6 shows a drawstring bag 60.

Figure 7 shows a loop handle bag 70.

Figure 8 shows a wave style bag 80.

Figure 9 shows a drawstring bag 90.

Figure 10 shows a T-sack 100 having handles 102 and 104; logo 106; printed information, such as a company message, or product or service information 108; a puzzle or contest 110; website information 112; phone number 114; social media link to a portal such as, Twitter or Facebook 116; and QR Code 118.

Figure 11 shows a die cut bag 120, having a die cut handle 122, a coupon 124 that can be peeled off of the bag 120, and a coupon 126 that can be cut from the bag 120.

Figure 11A shows a food storage bag 200 having food 202.

Figure 11B shows an empty food storage bag 200.

Figure 12A show a newspaper bag 204 having a newspaper 206.

Figure 12B shows an empty newspaper bag 204.

Figure 13 shows a tarp cover 208.

Figure 14 shows a pallet cover 210.

Figure 15A shows a mattress 212 in a mattress bag 214.

Figure 15B shows an empty mattress bag 214.

Figure 16A shows a furniture cover 216 over a sofa 218.

Figure 16B shows a furniture cover 216.

Figure 17 shows an examination or medical gown 220.

Figure 18 shows a lab coat 222.

Figure 19 shows an examination or medical cape 224.

Figure 20 shows examination shorts 226.

Figure 21 shows a poncho 228.

Figure 22 shows examination paper 230.

Figure 23A shows a drape 232.

Figure 23B shows a folded drape 232.

Figure 24A shows a packing list 234 in a plastic envelope 236 attached to a box.

Figure 24B shows the plastic packing list envelope 236.

Figure 25A shows an umbrella bag 238 with an umbrella 240.

Figure 25B shows an empty umbrella bag 238.

Figure 26 shows a soil liner 242 in a flower bed or in a garden.

In an embodiment the T-sack and/or T-shirt bags have a width of approximately 5" to 20", a height from 10" to 40" and a gusset from 2" to 15", with thickness ranging from approximately 0.25-4.0 mil.

In an embodiment the die cut bags have a width of approximately 5" to 30", a height from 5" to 30" and a gusset from 0.5" to 15", with a bag thickness of approximately 0.35 to 10.0 mil.

In an embodiment the loop handle bag has a width from about 3" to about 30", a height of 45" to about 30" and a gusset from 0.5" to 15", with a bag thickness of approximately 0.35 to 10.0 mil.

In an embodiment the tri-fold handle bag has a width from about 3" to 30", a height from 54" to 30" and a gusset from 0.5" to 15", with a bag thickness of approximately 0.35 to 10.0 mil.

In an embodiment the soft loop flat bag has a width of about 3" to 30" and a height from 5" to 30", with a bag thickness of approximately 0.35 to 10.0 mil.

In an embodiment the wave style bag has a width from about 3" to 30", a height from 5" to 30" and a gusset from 0.5" to 15", with a bag thickness of approximately 0.35 to 10.0 mil.

In an embodiment the drawstring bags have a width from about 5" to 30", a height of 5" to 30" and a gusset from 0.5" to 15", with a bag thickness of approximately 0.35 to 10.0 mil.

In an embodiment the drawstring cord bag has a width from about 5" to 30", a height of 5" to 30" and a gusset of 0.5 to 15" , with a bag thickness of approximately 0.35 to 10.0 mil.

In an embodiment the plastic bag or plastic composition comprises approximately 47-50% CaO₃, approximately 40% HDPE, approximately 10% LLPPE, and a filler/bonding agent of approximately 0-3%.

In an embodiment, the filler/bonding agent comprises an ester such as a long-chain (waxy) aliphatic ester. In a preferred embodiment, the filler/bonding agent is a waxy substrate such as a tallow based wax.

In an embodiment the CaCO₃ is approximately 20-30% of the weight of the composition for the bag or composition.

In an embodiment the HDPE and LLDPE are pre-blended and extruded into pellets.

In an embodiment approximately 35-40% CaCO₃ is used by weight for the composition of the bag or composition.

Independent lab tests done on a 1.0 mil thick Medium T-sack made with 25-35% CaCO₃, show that the T-sack performs just as well, if not better than a standard T-sack made with a polyethylene blend and approximately 5-10% CaCO₃. Tests performed

include tensile strength and elongation (ASTM D882), tear resistance (ASTM D1922), and puncture force (ASTM D5748-01).

Regarding the 1.0 mil thick Medium T-sack made with 25-35% CaCO₃, the tensile strength and elongation test done in the length direction showed a maximum load ranging from 3.25 to 4.25 lbf, with the elongation break ranging from 325% to 400%. The tensile strength and elongation test done in the width direction showed a maximum load ranging from 2.75 to 3.0 lbf, with the elongation break ranging from 550% to 625%.

Regarding the 1.0 mil thick Medium T-sack made with 25-35% CaCO₃, the tear resistance test done in the length direction showed results ranging from 15 to 18g. The tear resistance test done in the width direction showed results ranging from 300 to 360g.

Regarding the 1.0 mil thick Medium T-sack made with 25-35% CaCO₃, the puncture force test done showed a maximum load ranging from 4.1 to 5.1 lbf.

Claims

1. A plastic bag or plastic composition comprising:
approximately 20-49% calcium carbonate;
approximately 30-60% high density polyethylene;
approximately 0-20% linear low density polyethylene;
approximately 0-10% fillers/bonding agent;
said plastic bag or plastic composition being a single layer.
2. The plastic bag or plastic composition of claim 1 further comprising a biopolymer.
3. The plastic bag or plastic composition of claim 2 wherein said biopolymer is approximately 0.5% to 20% by weight of said plastic bag or plastic composition.
4. The plastic bag or plastic composition of claim 2 wherein said biopolymer is an amount less than 1.5%.
5. The plastic bag or plastic composition of claim 2 wherein said biopolymer is selected from the group consisting of: poly lactic acid, poly-hydroxybutanoate, poly-hydroxyalkanoate, Nylon 610, Nylon 611.
6. The plastic bag or plastic composition of claim 1 wherein said plastic composition or plastic bag contains no fibers.
7. The plastic bag or plastic composition of claim 1 wherein said external surface of said plastic bag or plastic composition has a printable surface.
8. The plastic bag or plastic composition of claim 1 wherein said external surface of said plastic bag or plastic composition has a smooth surface.

9. The plastic bag or plastic composition of claim 1 wherein said plastic bag or plastic composition provides a moisture barrier.
10. The plastic bag or plastic composition of claim 1 wherein said plastic bag or plastic composition is biodegradable.
11. The plastic bag of claim 1 wherein said bag is a T-sack or T-shirt bag.
12. The plastic bag of claim 1 wherein said bag is a, die cut bag, loop handle bag, tri-fold handle bag, soft loop flat bag, wave style bag, drawstring bag or drawstring cord bag.
13. The plastic bag or plastic composition of claim 1 wherein said plastic bag or plastic composition comprises printed information.
14. The plastic bag or plastic composition of claim 1 wherein said plastic bag or plastic composition comprises a barcode.
15. The plastic bag or plastic composition of claim 1 wherein said plastic bag or plastic composition comprises a coupon.
16. The plastic bag or plastic composition of claim 2 wherein said plastic bag or plastic composition is compostable.
17. A plastic bag or plastic composition comprising:
 - approximately 20-49% mineral material;
 - approximately 30-60% high density polyethylene;
 - approximately 0-20% linear low density polyethylene;
 - approximately 0-10% fillers/bonding agents;said plastic bag or plastic composition being a single layer.

18. The plastic bag or plastic composition of claim 17 wherein said mineral material is selected from the group consisting of calcium carbonate, calcium sulfate, barium sulfate, kaolin, mica, zinc oxide, dolomite, glass fiber, hollow glass microbead, silica, chalk, talc, pigment, titanium dioxide, bentonite, clay, zeolite, slate, diatomaceous earth and combinations thereof.
19. The plastic bag or plastic composition of claim 17 further comprising a biopolymer.
20. The plastic bag or plastic composition of claim 19 wherein said biopolymer is approximately 0.5% to 20% by weight of said plastic bag or plastic composition.
21. The plastic bag or plastic composition of claim 19 wherein said biopolymer is an amount less than 1.5%.
22. The plastic bag or plastic composition of claim 19 wherein said biopolymer is selected from the group consisting of: poly lactic acid, poly-hydroxybutanoate, poly-hydroxyalkanoate, Nylon 610, Nylon 611.
23. The plastic bag or plastic composition of claim 17 wherein said plastic bag or plastic composition contains no fibers.
24. The plastic bag or plastic composition of claims 17 wherein said external surface of said plastic bag or plastic composition has a printable surface.
25. The plastic bag or plastic composition of claim 17 wherein said external surface of said plastic bag or plastic composition has a smooth surface.
26. The plastic bag or plastic composition of claim 17 wherein said plastic bag or plastic composition provides a moisture barrier.

27. The plastic bag or plastic composition of claim 17 wherein said plastic bag or plastic composition is biodegradable.
28. The plastic bag of claim 17 wherein said bag is a T-sack or T-shirt bag.
29. The plastic bag of claim 17 wherein said bag is a, die-cut bag, loop-handle bag, tri-fold bag, soft loop flat bag, wave style bag, drawstring bag or drawstring cord bag.
30. The plastic bag or plastic composition of claim 17 wherein said plastic bag or plastic composition comprises printed information.
31. The plastic bag or plastic composition of claim 17 wherein said plastic bag or plastic composition comprises a barcode.
32. The plastic bag or plastic composition of claim 17 wherein said plastic bag or plastic composition comprises a coupon.
33. The plastic bag or plastic composition of claim 19 wherein said plastic bag or plastic composition is compostable.
34. A plastic bag or plastic composition comprising:
approximately 25-40% calcium carbonate;
approximately 30-50% high density polyethylene;
approximately 5-15% linear low density polyethylene;
approximately 2-7% filler/bonding agent;
said plastic bag or plastic composition being a single layer.
35. The plastic bag or plastic composition of claim 34 further comprising a biopolymer.
36. A plastic bag or plastic composition comprising:
approximately 20-49% mineral material;

approximately 30-60% high density polyethylene;

approximately 0-20% low density polyethylene, linear low density polyethylene
or a combination thereof;

approximately 0-10% fillers/bonding agent;

said plastic bag or plastic composition being a single layer.

37. The plastic bag or plastic composition of claim 36 further comprising a
biopolymer.

38. A plastic bag or plastic composition comprising:

calcium carbonate;

high density polyethylene;

linear low density polyethylene; and

a filler/bonding agent;

said plastic bag or plastic composition being a single layer.

39. The plastic bag or plastic composition of claim 38 wherein said calcium carbonate
comprises less than 50% by weight of said plastic bag or plastic composition.

40. The plastic bag or plastic composition of claim 38 further comprising a
biopolymer.

41. A plastic bag or plastic composition comprising :

calcium carbonate;

high density polyethylene;

low density polyethylene, linear low density polyethylene or a combination; and

a filler /bonding agent;

said plastic bag or plastic composition being a single layer.

42. The plastic bag or plastic composition of claim 41 wherein said calcium carbonate comprises less than 50% by weight of said plastic bag or plastic composition.
43. The plastic bag or plastic composition of claim 41 further comprising a biopolymer.
44. The plastic composition of claim 36 wherein said plastic composition is used for plastic bags, sacks, pouches and wrappers.
45. The plastic composition of claim 36 further comprising an antimicrobial component.
46. The plastic composition of claim 36 wherein said plastic composition is formed into a bag, cover, sheet, protective garment, school, office or warehouse supply, storage bag, medical examination paper, bedding sheets, soil liner bubble mailer, mailing labels, protective films, stretch wrap films and tapes.
47. The plastic composition of claim 36 wherein said plastic composition is wound on a roll.
48. The plastic composition of claim 36 wherein said plastic composition is perforated.

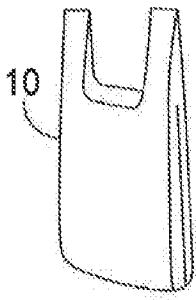

FIG. 1

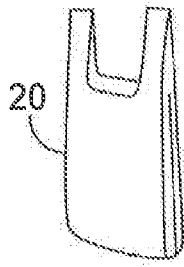

FIG. 2

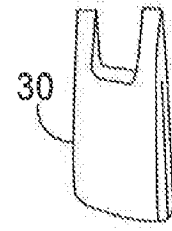

FIG. 3

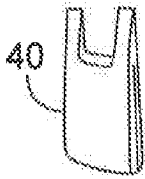

FIG. 4



FIG. 5

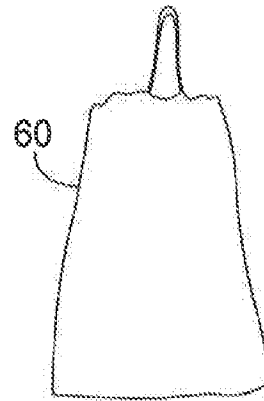

FIG. 6

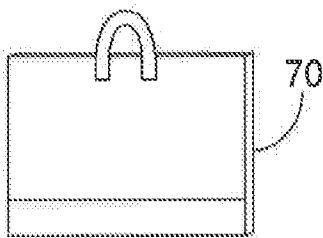

FIG. 7

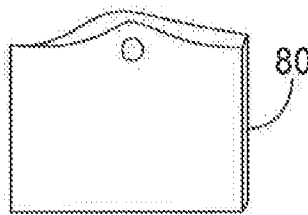

FIG. 8

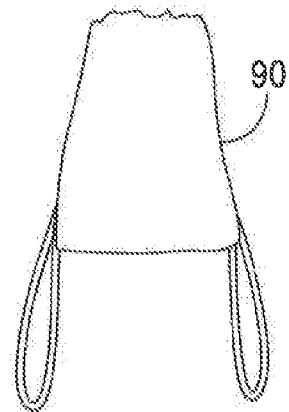

FIG. 9

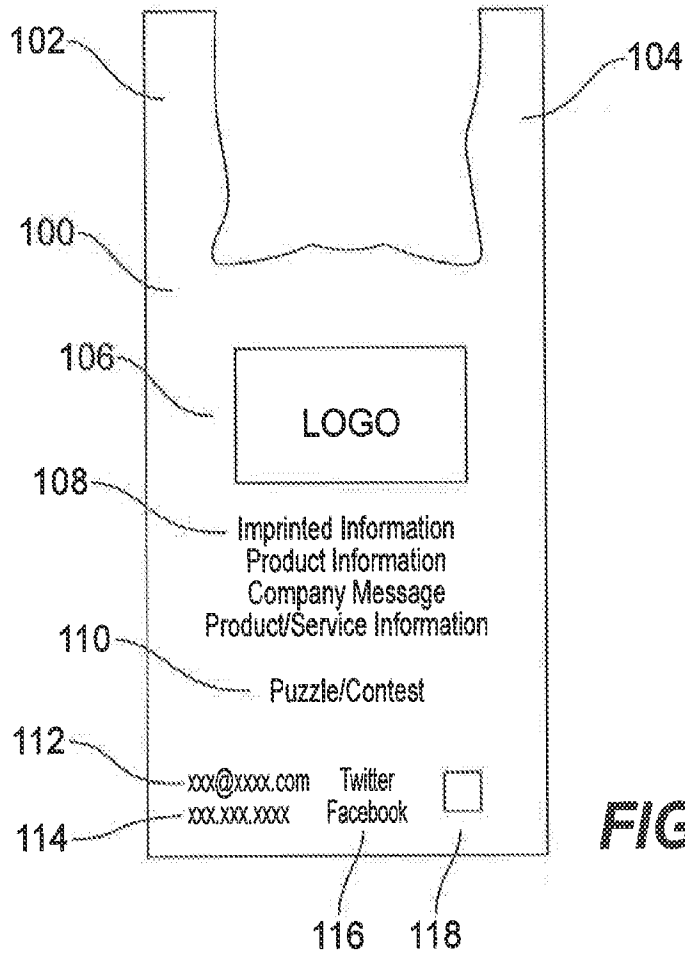

FIG. 10

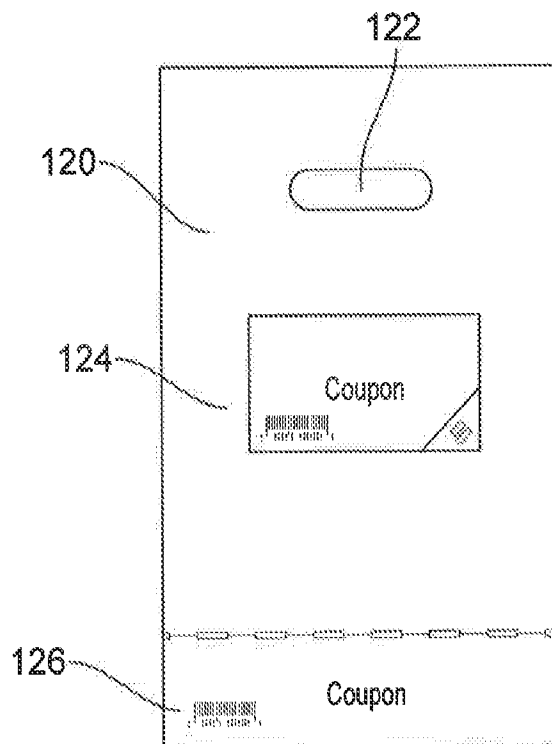

FIG. 11

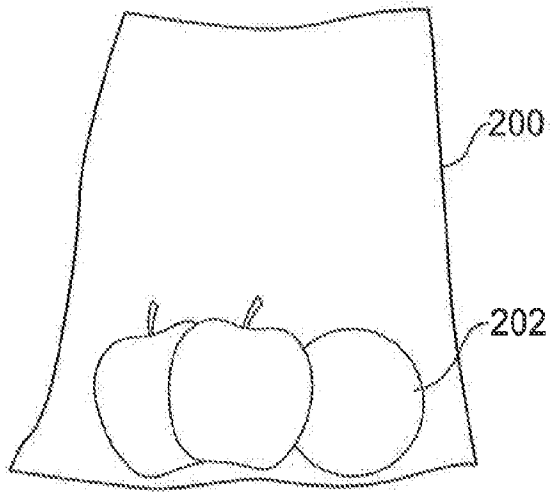

FIG. 11A

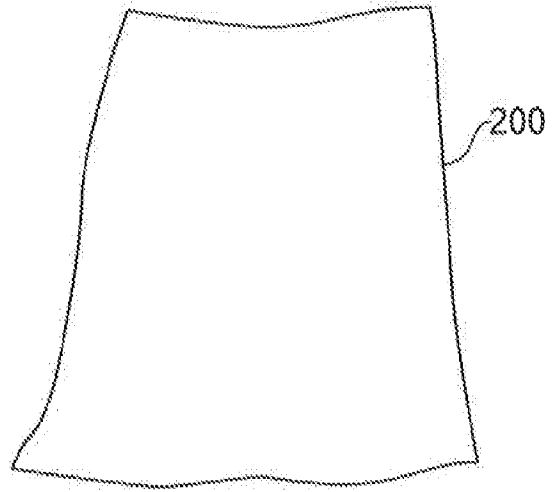

FIG. 11B

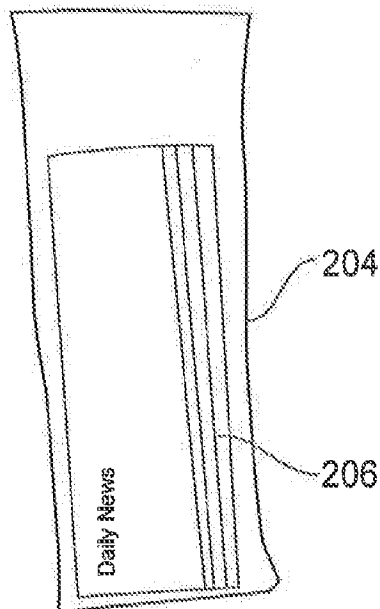

FIG. 12A

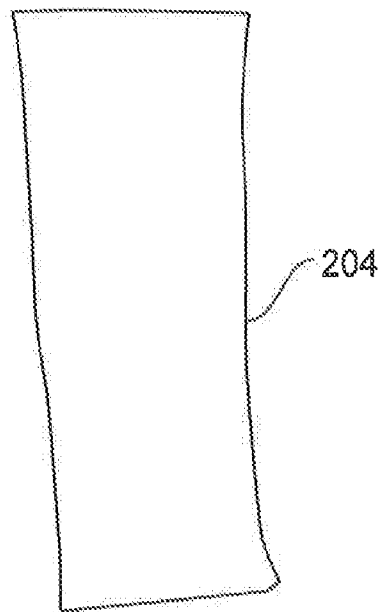

FIG. 12B

4/9

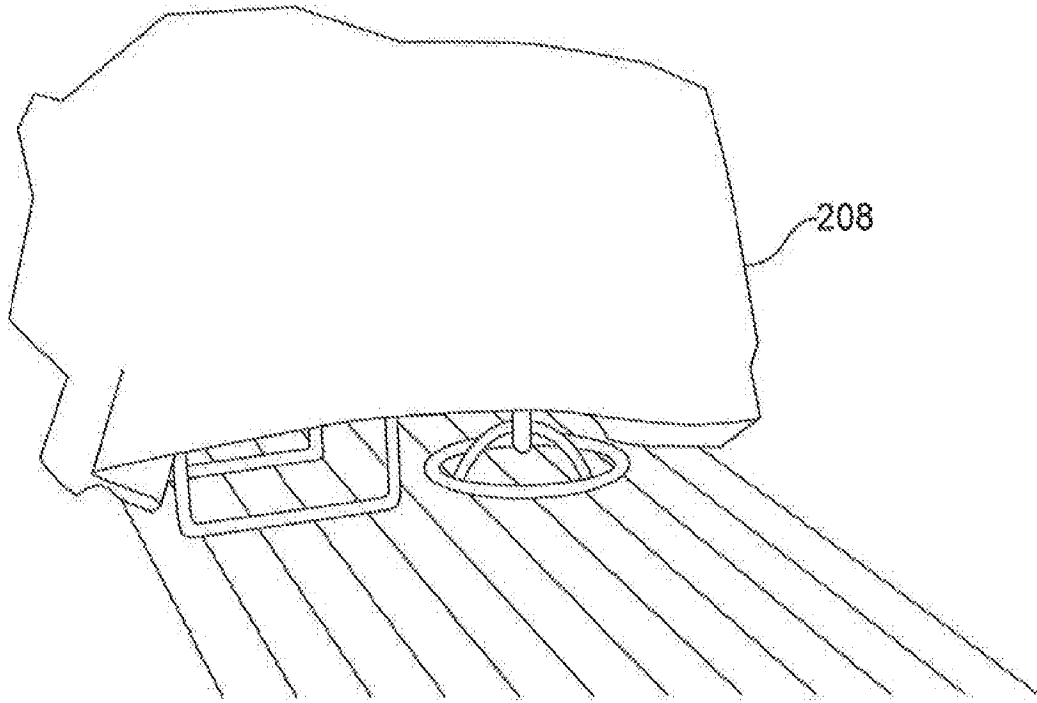

FIG. 13

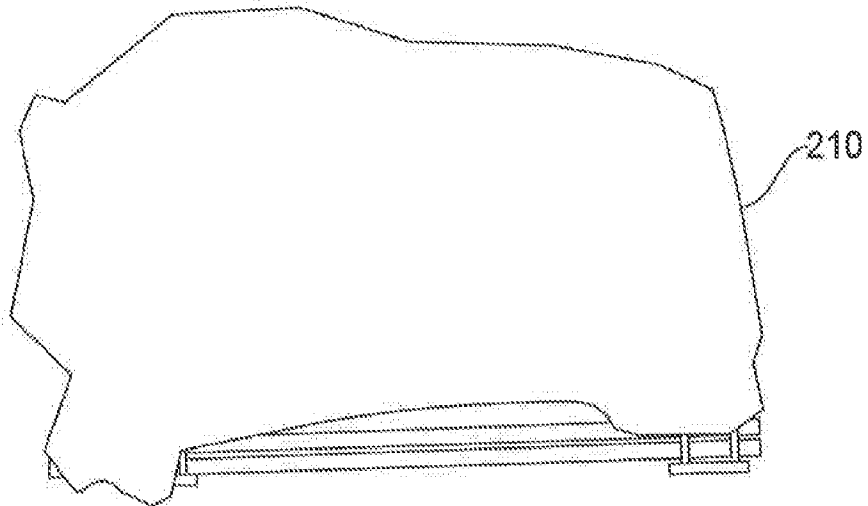

FIG. 14

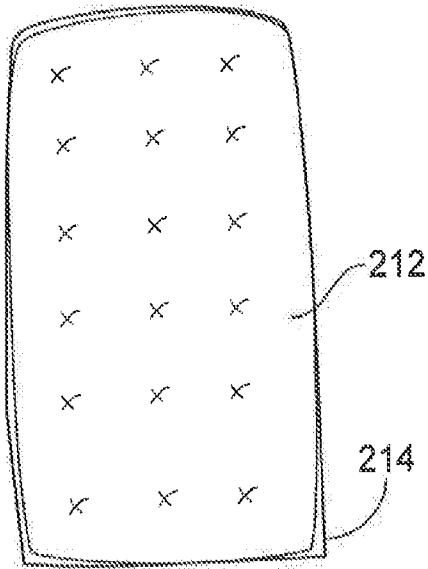

FIG. 15A

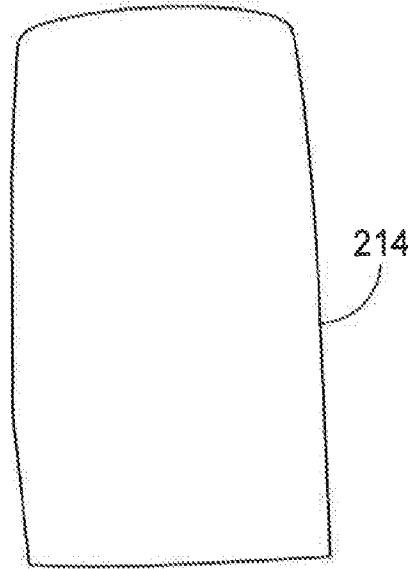

FIG. 15B

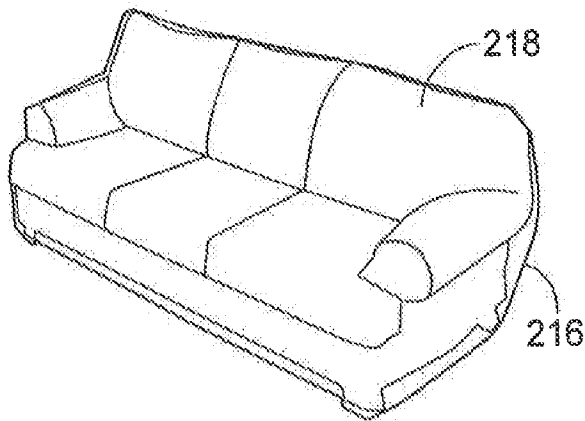

FIG. 16A

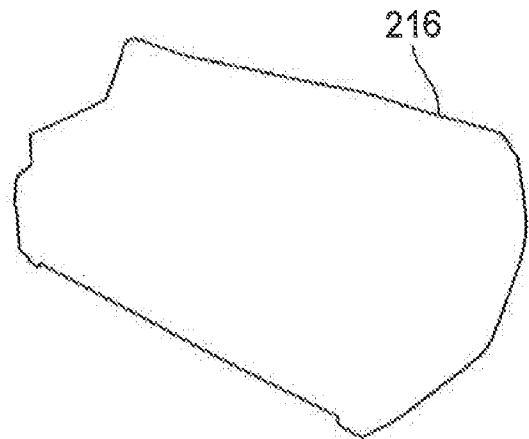

FIG. 16B

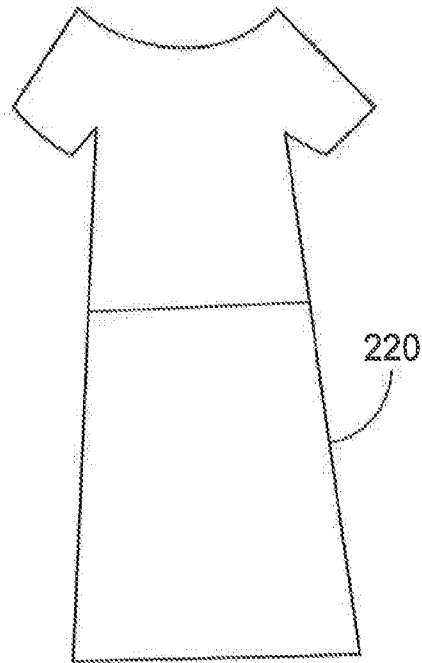

FIG. 17

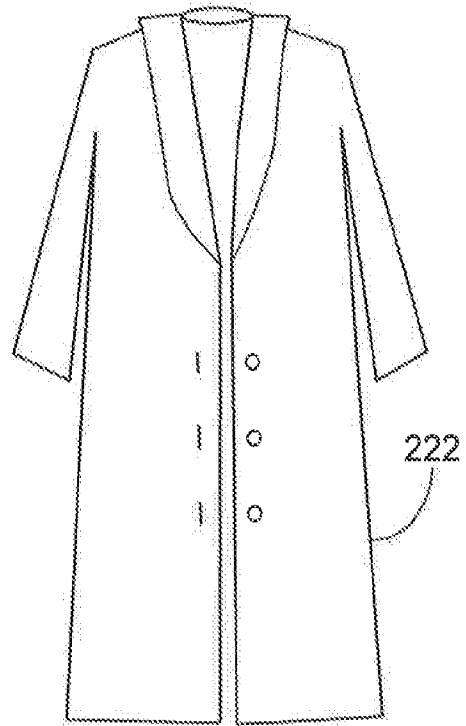

FIG. 18

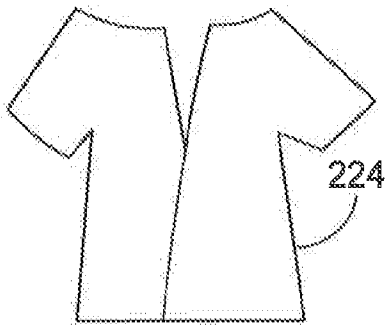

FIG. 19

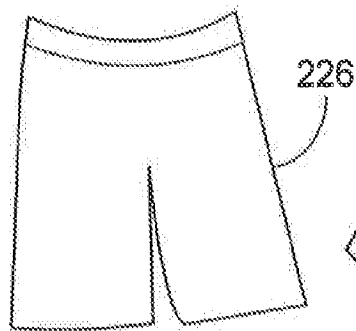

FIG. 20

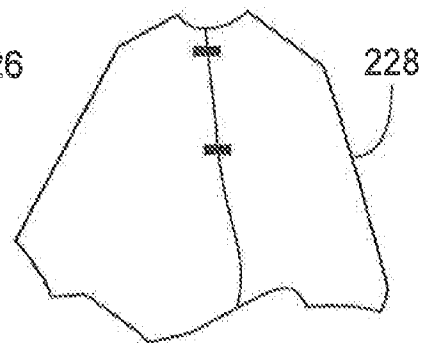

FIG. 21

7/9

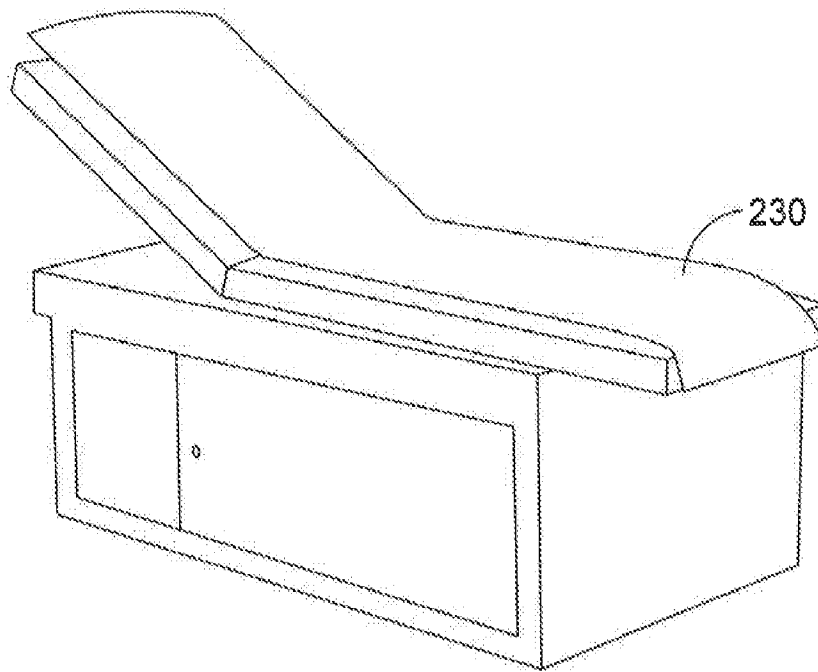

FIG. 22

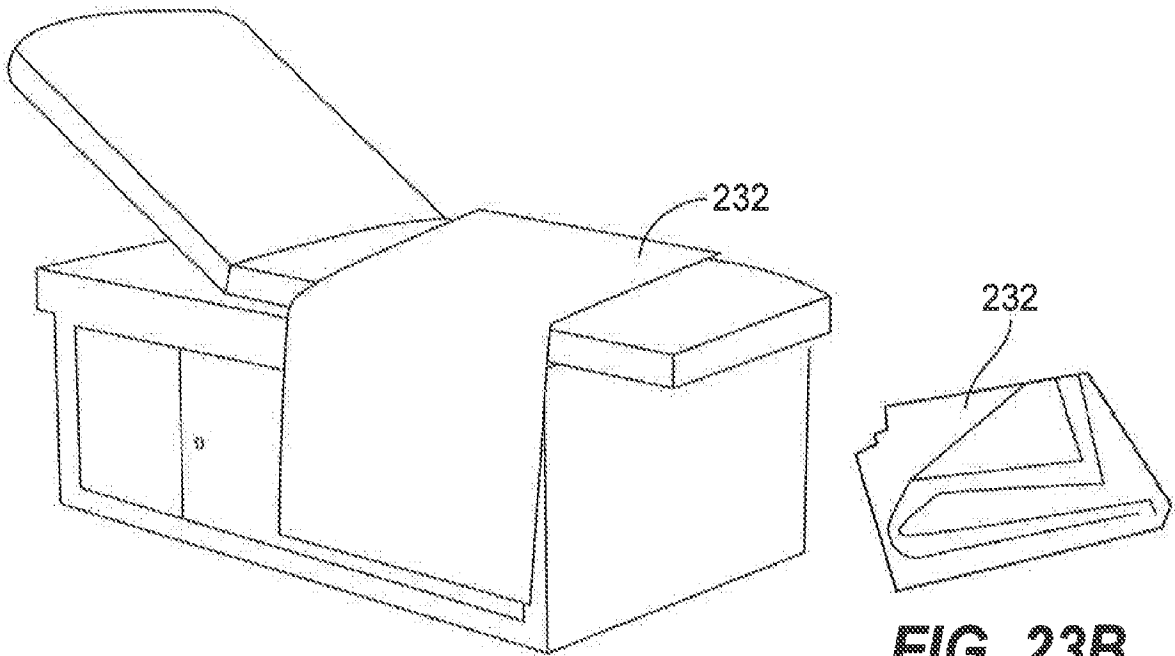

FIG. 23A

FIG. 23B

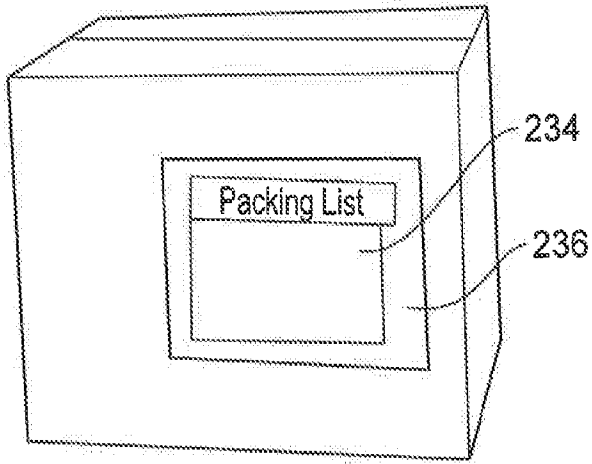

FIG. 24A



FIG. 24B

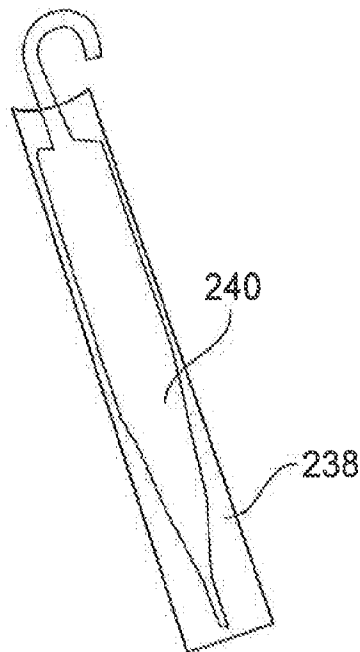

FIG. 25A

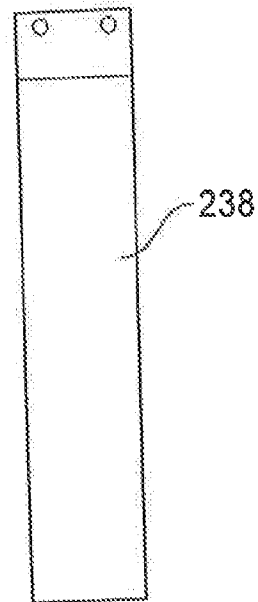

FIG. 25B

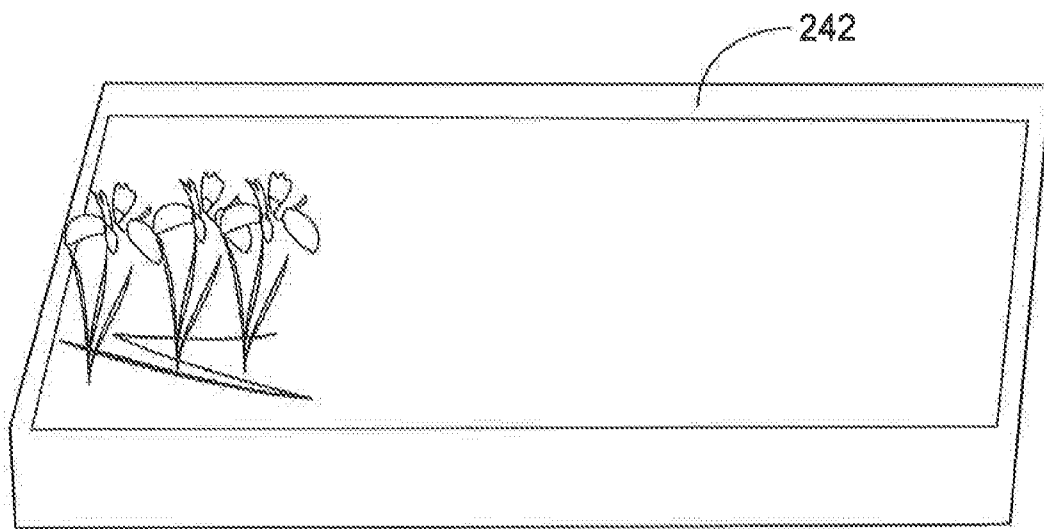

FIG. 26

INTERNATIONAL SEARCH REPORT

International application No.

PCT/US 16/67035

A. CLASSIFICATION OF SUBJECT MATTER
 IPC(8) - C08L 23/12, C08L 23/06, C08I 3/02 (2017.01)
 CPC - C08L 3/02, C08L 23/12, C08L 23/08

According to International Patent Classification (IPC) or to both national classification and IPC

B. FIELDS SEARCHED

Minimum documentation searched (classification system followed by classification symbols)
 IPC(8)- C08L 23/12, C08L 23/06, C08I 3/02 (2017.01)
 CPC- C08L 3/02, C08L 23/12, C08L 23/08

Documentation searched other than minimum documentation to the extent that such documents are included in the fields searched

Electronic data base consulted during the international search (name of data base and, where practicable, search terms used)
 PatBase, Google Patents, Google Scholar (without Patents)
 Keywords: plastic bag plastic composition calcium carbonate high density polyethylene

C. DOCUMENTS CONSIDERED TO BE RELEVANT

Category*	Citation of document, with indication, where appropriate, of the relevant passages	Relevant to claim No.
X ---- Y	US 2009/0324979 A1 (Roussel et al.) 31 December 2009 (31.12.2009) Abstract, para [0006], para [0003], para [0015], para [0014], para [0045], para [0049], para [0010], Table 2 and entire document	1,6-9,11-15,17,18,23-26,28-32,34,36,38,39,41,42,44-48 ----- 2-5,10,16,19-22,27,33,35,37,40,43
Y	US 2011/0171489 A1 (Dou et al.) 14 July 2011 (14.07.2011) Abstract, para [003], para [0049], para [0026], para [0059], para [0002], para [0016] and entire document	2-5,10,16,19-22,27,33,35,37,40,43
A	US 2003/0039775 A1 (Kong) 27 February 2003 (27.02.2003) Abstract, para [019]-[035]	1-48
A	US 2014/0302298 A1 (Wilfong et al.) 09 October 2014 (09.10.2014) Abstract, para [008]-[022]	1-48
A	US 6,599,622 B1 (Chu et al.) 29 July 2003 (29.07.2003) Abstract, col 2 ln 10-50	1-48

Further documents are listed in the continuation of Box C.

* Special categories of cited documents:	"T" later document published after the international filing date or priority date and not in conflict with the application but cited to understand the principle or theory underlying the invention
"A" document defining the general state of the art which is not considered to be of particular relevance	"X" document of particular relevance; the claimed invention cannot be considered novel or cannot be considered to involve an inventive step when the document is taken alone
"E" earlier application or patent but published on or after the international filing date	"Y" document of particular relevance; the claimed invention cannot be considered to involve an inventive step when the document is combined with one or more other such documents, such combination being obvious to a person skilled in the art
"L" document which may throw doubts on priority claim(s) or which is cited to establish the publication date of another citation or other special reason (as specified)	"&" document member of the same patent family
"O" document referring to an oral disclosure, use, exhibition or other means	
"P" document published prior to the international filing date but later than the priority date claimed	

Date of the actual completion of the international search 30 January 2017	Date of mailing of the international search report 31 MAR 2017
------------------------------------------------------------------------------	--------------------------------------------------------------------------

Name and mailing address of the ISA/US Mail Stop PCT, Attn: ISA/US, Commissioner for Patents P.O. Box 1450, Alexandria, Virginia 22313-1450 Facsimile No. 571-273-8300	Authorized officer: Lee W. Young PCT Helpdesk: 571-272-4300 PCT OSP: 571-272-7774
---------------------------------------------------------------------------------------------------------------------------------------------------------------------------------	------------------------------------------------------------------------------------------------