

(No Model.)

O. SMITH.  
WHEEL WRENCH.

No. 524,770.

Patented Aug. 21, 1894.

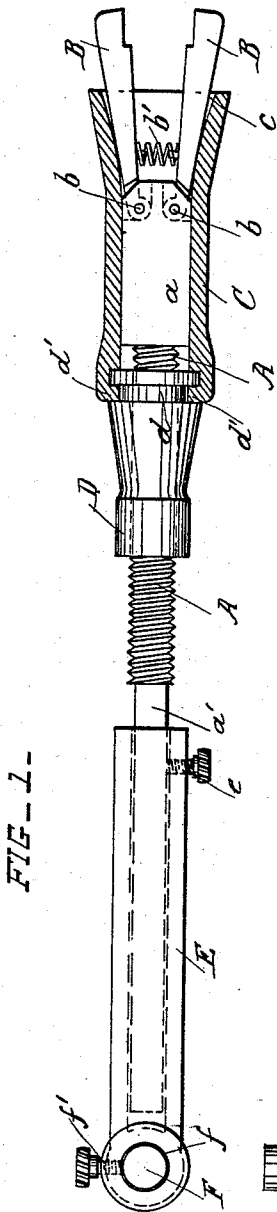

FIG. 1-

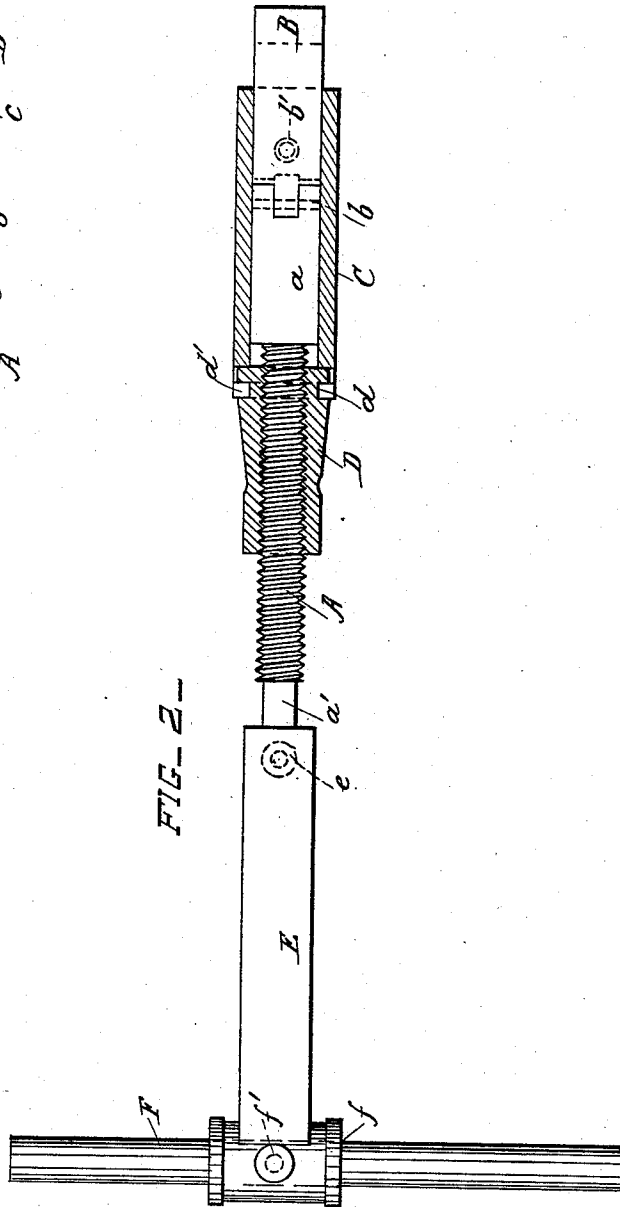

FIG. 2-

WITNESSES

*George H. Bliss*  
*Wm. A. Cox*

INVENTOR

*Olin Smith*  
*by Herbert W. Jenner*  
Attorney

# UNITED STATES PATENT OFFICE.

ORIN SMITH, OF CROOKED TREE, OHIO.

## WHEEL-WRENCH.

SPECIFICATION forming part of Letters Patent No. 524,770, dated August 21, 1894.

Application filed February 28, 1894. Serial No. 501,798. (No model.)

*To all whom it may concern:*

Be it known that I, ORIN SMITH, a citizen of the United States, residing at Crooked Tree, in the county of Noble and State of Ohio, have invented certain new and useful Improvements in Wheel-Wrenches; and I do hereby declare the following to be a full, clear, and exact description of the invention, such as will enable others skilled in the art to which it appertains to make and use the same.

This invention relates to wrenches and more particularly to that class of wrenches adapted to turn the nuts screwed on the ends of vehicle axles, and in other positions in which the nuts cannot be readily engaged by ordinary wrenches.

This invention consists in the novel construction and combination of the parts hereinafter fully described and claimed.

In the drawings: Figure 1 is a side view of the wrench, partly in section. Fig. 2 is also a side view, partly in section, but shows the wrench turned around one quarter from the position shown in Fig. 1.

A is a screwthreaded rod provided with a rectangular head portion *a*, and a rectangular end *a'*.

B are jaws for engaging the nut. These jaws are pivoted on the pins *b* in sockets formed in the end of the head portion *a*, and are provided with a spring *b'* for pressing them apart.

C is a guide which slides upon the head portion *a*, and is provided with a flaring mouth *c* which bears against the backs of the jaws.

D is a screwthreaded sleeve mounted on the rod A, and provided with a circumferential groove *d* at its front end. The guide C is provided with hooked flanges *d'* at its rear end, and these flanges engage with the groove *d*. The guide is moved back and forth upon the head portion by turning the sleeve. When the sleeve is moved forward the jaws are pressed upon the nut, and will engage with any size of nut within the limit of the largest size they can span when moved apart to their greatest extent. When the sleeve is moved back the spring *b'* releases the nut from the jaws.

E is a rectangular socket which is slid upon the end *a'* of the rod A. A screw *e*, or other approved fastening device, is provided for securing the socket to the end of the rod, and the socket may be slid upon the said end so as to give more or less leverage in turning nuts, as may be found requisite.

F is a handle bar which is passed transversely through a hole *f* at the end of the socket E; and *f'* is a screw, or other approved fastening device, for securing the handle bar to the socket. The handle bar is removable, and handle bars of different lengths may be substituted for it to give the required leverage in turning the nut. When the handle bar and the end of the socket are grasped by the right hand in the act of screwing up nuts of medium size, the guide C is grasped loosely by the left hand so that the wrench is supported and kept from slipping off the nut.

What I claim is—

1. In a wheel wrench, the combination, with the screwthreaded bar provided with a rectangular head portion, the jaws pivoted to the said head portion, and the spring for forcing the jaws apart; of the guide sliding on the said head portion and provided with a flaring mouth, and the revoluble screwthreaded sleeve engaging with the said bar and operatively connected to the said guide, whereby the said guide is slid back and forth, substantially as set forth.

2. In a wheel wrench, the combination, with the screwthreaded bar provided with a rectangular head portion and a rectangular end, the jaws pivoted to the said head portion, the sliding guide, and the screwthreaded sleeve operatively connected to the said guide; of the adjustable socket slid upon the end of the said bar and provided with a handle, and a fastening device for securing the socket on the end of the bar, substantially as set forth.

In testimony whereof I affix my signature in presence of two witnesses.

ORIN SMITH.

Witnesses:

A. GROVES,  
CHAS. KEITH.