



(11) **EP 3 713 452 B1**

(12) **EUROPEAN PATENT SPECIFICATION**

(45) Date of publication and mention of the grant of the patent:

10.01.2024 Bulletin 2024/02

(21) Application number: **18826444.4**

(22) Date of filing: **16.11.2018**

(51) International Patent Classification (IPC):

A47C 27/00^(2006.01) A47C 27/14^(2006.01)

(52) Cooperative Patent Classification (CPC):

A47C 27/006; A47C 27/146

(86) International application number:

PCT/IB2018/059043

(87) International publication number:

WO 2019/102325 (31.05.2019 Gazette 2019/22)

(54) **MATTRESS**

MATRATZE

MATELAS

(84) Designated Contracting States:

AL AT BE BG CH CY CZ DE DK EE ES FI FR GB GR HR HU IE IS IT LI LT LU LV MC MK MT NL NO PL PT RO RS SE SI SK SM TR

(30) Priority: **21.11.2017 IT 201700133206**

(43) Date of publication of application:

30.09.2020 Bulletin 2020/40

(73) Proprietor: **Buoninfante, Vincenzo**

84096 Montecorvino Rovella (SA) (IT)

(72) Inventor: **Buoninfante, Vincenzo**

84096 Montecorvino Rovella (SA) (IT)

(74) Representative: **Fisauli, Beatrice A. M.**

**Con Lor S.p.A
Via Bronzino, 8
20133 Milano (IT)**

(56) References cited:

**WO-A1-01/11127 DE-A1- 19 542 210
DE-U1- 20 309 795 US-A1- 2006 189 955
US-A1- 2017 079 444**

EP 3 713 452 B1

Note: Within nine months of the publication of the mention of the grant of the European patent in the European Patent Bulletin, any person may give notice to the European Patent Office of opposition to that patent, in accordance with the Implementing Regulations. Notice of opposition shall not be deemed to have been filed until the opposition fee has been paid. (Art. 99(1) European Patent Convention).

Description

[0001] The present invention refers, in general, to a mattress. More particularly, the present invention refers to a mattress with excellent properties of thermoregulation, transpiration and humidity management so as to ensure a high **Matresses with particular features are known from US** comfort to the user at rest. 2006/189955 A1, WO 01/11127 A1, US 2017/079444 A1.

[0002] Most of the mattresses according to the known art have poor thermoregulation properties.

[0003] Indeed, when the ideal microclimate of the bed is altered, for example in hot or humid conditions, rest and in particular sleep is disturbed; the body tends to sweat to cool down in order to keep the body temperature at a constant level, which involves, first of all, a consumption of energy by the user's body but this aspect is counterproductive for a good rest.

[0004] At the same time, sweating is likely to create a wet microclimate in the bed, in particular in the mattress, with immediate problems such as undesirable thermal changes, and long-term problems such as the creation of an unhygienic environment.

[0005] An object of the invention is to overcome the aforementioned drawbacks and still others through a mattress capable of guaranteeing optimal thermoregulation of the user's body resting on the mattress.

[0006] Another object of the invention is to provide a mattress allowing to optimally manage the humidity generated by body sweat.

[0007] Another object of the invention is to provide a mattress guaranteeing a high level of hygiene and, at the same time, having anti-mite, antibacterial and anti-odor functions.

[0008] The aforesaid objects and still others are reached by means of a mattress according to the invention as defined in claim 1.

[0009] The coating structure includes an intermediate fabric having an alveolar structure with transpiring and hygroscopic properties.

[0010] The presence of said fabric allows humidity to be absorbed by the mattress surface that is in contact with the user's body and transported towards the most peripheral parts of the mattress.

[0011] Advantageously, the thickness of the intermediate fabric can be greater than 2 mm. so as to get enough space for the absorption of the humidity due to the sweat of the user's body.

[0012] Besides, the coating structure may include an insulation fabric interposed between the internal portion and the intermediate fabric; said insulation fabric being waterproof so as to isolate the inside of the mattress from humidity.

[0013] In this way, the hygienic conditions of the mattress are guaranteed even in the long term.

[0014] Advantageously, the coating structure may include a covering fabric, said covering fabric being arranged superiorly to the intermediate fabric and having

hygroscopic properties.

[0015] The coating fabric is, therefore, the interface of the mattress with the user's body. Said fabric guarantees humidity absorption from the user's body so that the humidity can be managed by the intermediate fabric.

[0016] In order to improve the properties of absorption and transport of humidity, the coating structure may include at least one microduct that is permeable to water.

[0017] According to the invention, the coating structure includes at least one longitudinal microduct that develops in the coating structure in the direction of maximum length of the mattress.

[0018] In this way, humidity can be absorbed in the central area of the mattress and brought towards the head and feet of the user.

[0019] Besides, the coating structure may comprise at least one transverse microduct that develops in the coating structure in the direction of minimum length of the mattress so as to transport the humidity from the central part of the mattress to the lateral areas where the humidity is discharged to the outside.

[0020] The one or more transverse microducts may be orthogonal to the one or more longitudinal microducts so as to create a sort of netting and maximize the properties of absorption and discharge of humidity.

[0021] Advantageously, in order to guarantee an excellent comfort also in the case of low use temperatures, the coating structure may comprise at least one portion including a woolen fabric.

[0022] Further features and details of the invention will be better understood from the following specification that is provided by way of a non-limiting example as well as from the accompanying drawing, wherein:

Figure 1 is a schematic axonometric view of a mattress according to the invention;

Figure 2 is a schematic side view of a portion of the mattress in Fig. 1, sectioned transversally.

[0023] With reference to the annexed figures, number 10 denotes a mattress including an internal portion 12 shaped like a parallelepiped and covered by a coating structure 14 externally.

[0024] The function of the internal portion 12 is to support the user lying on the mattress. In fact, the internal portion has an elastoplastic behavior and is made of a polymer foam, according to the known art.

[0025] Obviously, the internal portion 12 can be produced by using another material, for example latex or another natural or artificial material. Otherwise, the internal portion can be obtained by using a spring system.

[0026] The coating structure 14 is a multi-layer structure for it includes three fabrics that are laid one upon the other.

[0027] In particular, the coating structure 14 includes an external covering fabric 16, an intermediate fabric 18 and an internal insulation fabric 20.

[0028] The external covering fabric 16 has excellent

hygroscopic and breathable properties and ensures a partial evaporation of humidity, i.e. the sweat of the body of the person lying on the mattress, as well as the passage of the humidity remaining inside the coating structure 14, specifically in the intermediate fabric 18.

[0029] In this way, the external surface of the covering fabric 16, i.e. the surface that is in potential contact with the user's body, remains basically dry.

[0030] The thickness of the intermediate fabric 18 is greater than 2 mm, i.e. greater than the thickness of the covering fabric 16 and insulation fabric 20 because the intermediate fabric 18 has an alveolar structure with particular transpiration characteristics.

[0031] The alveolar structure of the intermediate fabric 18 allows the passage of air and humidity, for example that of body sweat.

[0032] Since the intermediate fabric 18 covers all the external surface of the internal portion 12, the intermediate fabric 18 allows an exchange of humidity between the various portions of the most external surface of the mattress.

[0033] Besides, the alveolar structure of the intermediate fabric 18 forms a cushion that increases comfort during rest.

[0034] The most internal insulation fabric 20 is impermeable to liquids and air. In other words, the insulation fabric 20 prevents humidity and air from entering the internal portion 12 of the mattress 10.

[0035] In this way, the mattress remains totally isolated even in its innermost part and keeps the characteristics of support of the person lying on the mattress always intact.

[0036] Besides, longitudinal microducts 22 and transverse microducts 24 are present on the surface of the mattress 10 inside the coating structure 14, precisely in the outer covering fabric 16 .

[0037] The longitudinal microducts 22 develop in the coating structure 14 from the head position to the feet position of the user.

[0038] The transverse microducts 24 develop orthogonally to the longitudinal microducts 22, i.e. the transverse microducts cross the structure from one side to the other.

[0039] The microducts 22, 24 can be evenly distributed over the entire coating structure 14 of the mattress or can be present only in some specific areas of said coating structure.

[0040] In particular, the transverse microducts 24 are present, preferably, on the the areas of the coating structure 14 where the contact of the user's body with the mattress is greater, said areas being generally two or three. More particularly, in a first area there is a first group of transverse microducts 24 at the level of the position that is reserved for the head and/or the shoulders and the back at the level of the chest, and in a second area there is a second group of transverse microducts 24 at the level of the position that is reserved for the pelvis and thighs, with reference to the user lying in a supine posi-

tion. For example, in a single mattress, the transverse microducts 24 can be indicatively in a number from 10 to 20 in each group so as to ensure good comfort. Naturally, if two or more groups of transverse microducts 24 are present, the groups can have an equal or different number of transverse microducts 24. Besides, all the transverse microducts 24 in each group can be equidistant from each other or, more preferably, at least one transverse microduct 24 is more distant from the transverse microduct 24 on the side than the distance between the other transverse microducts 24 belonging to the same group. The greatest distance between the transverse microducts 24 is found in correspondence with the area of least contact of the user's body with the mattress, namely the area of the user's thighs and head.

[0041] The microducts 22, 24 are in a variable number that is not binding for the purposes of the present invention and depends mainly on the size of the mattress and the comfort you want to bring to the user of the mattress. For example, the longitudinal microducts 22 in a single mattress can be indicatively in a number from 6 to 10 so as to ensure good comfort. The longitudinal microducts 22 can be equidistant from each other or grouped into a number of two or more. Besides, the longitudinal microducts 22 can be at least partially parallel to each other or can follow, at least partially, a particular pattern.

[0042] The function of the longitudinal microducts 22 and transverse microducts 24 is to absorb humidity, i.e. sweat, in the areas of higher concentration, and transport it to the areas of lower concentration, where it is released.

[0043] The longitudinal microducts 22 and the transverse microducts 24 are therefore made of a breathable and permeable fabric so as to allow absorption or expulsion of moisture, or sweat, depending on the degree of moisture concentration within a given portion of a microduct of the longitudinal microducts 22 or transverse microducts 24.

[0044] Hence, in the event that a microduct portion is completely filled with sweat, the sweat itself will be conveyed to microduct portions with lower humidity or will be expelled towards the outside of the mattress, provided that the moisture content in the adjacent covering fabric 16 is lower than that of the same microduct portion.

[0045] In this way, the humidity is transported from the areas of humidity production where it is originally warm to other areas of the mattress and therefore of the user's body where the humidity arrives fresh and therefore, it is capable to cool down the user's body itself.

[0046] The mattress 10 according to the invention allows, therefore, to taking advantage of the body sweat and use it for the benefit of rest.

[0047] The body sweat and humidity pass through the covering fabric 16 into the coating structure 14 but do not penetrate the internal portion 12 of the mattress 10 owing to the presence of the insulation fabric 20 and flow outwards.

[0048] The humidity does not enter the mattress but flows inside the intermediate fabric 18 and inside the lon-

gitudinal microducts 22 and transverse microducts 24.

[0049] In fact, air and humidity can pass through the alveolar structure of the intermediate fabric 18 that forms even a cushion so as to improve the comfort during rest.

[0050] More precisely, a part of the sweat evaporates in the covering fabric 16 and intermediate fabric.

[0051] Another part is canalized in the longitudinal microducts 22 and transverse microducts 24 which convey sweat from the areas of high concentration to the areas of lower concentration on the whole surface of the mattress.

[0052] In this way, humidity is conveyed from the production areas where it is originally warm, to other body areas where humidity arrives fresh.

[0053] Besides, a part of the sweat is thus reabsorbed as fresher by the skin of the user, so that the user's body spends less energy to cool down since there is substantially a recycling of the sweat.

[0054] Very low energy consumption to thermo-regulate the organism leads to a better quality of sleep and rest.

[0055] Moreover, the particular shape of the mattress 10 avoids the accumulation of mites and bacteria inside the mattress.

[0056] In essence, the mattress according to the invention offers an excellent level of hygiene thanks to the absence of humidity in its inside and thanks to the anti-mite, antibacterial and anti-odor functions.

[0057] The mattress according to the invention is therefore ideal for people who practice sports since this mattress allows a better muscle and organic recovery.

[0058] A skilled artisan in this field can provide changes or variants that are to be considered as included in the scope of protection of the present invention.

[0059] For example, the coating structure 14 can include additional layers of fabric that perform different functions.

[0060] For example, the coating structure 14 can include wool so as to ensure an optimal management of the user's body temperature.

[0061] According to a variant of the invention, the most internal insulation fabric can be breathable while remaining waterproof to liquids.

Claims

1. Mattress (10) suitable for ensuring the thermoregulation and the transpiration of the body of a user lying on the mattress so as to guarantee a high comfort for the user at rest, the mattress comprising an internal portion (12) with support function for the user's body, and a coating structure (14) arranged on the external surface of the internal portion (12) and adapted to come into contact with the user's body, wherein the coating structure (14) includes an intermediate fabric (18) having an alveolar structure with transpiring and hygroscopic properties, wherein the

coating structure (14) includes at least one microduct (22, 24), permeable to water, which is adapted to absorb water from the surface of the mattress and transport it; **characterized by** the fact that the coating structure (14) includes at least one longitudinal microduct (22) that develops in the coating structure (14) in the direction of maximum length of the mattress.

2. Mattress (10) according to the preceding claim, wherein the thickness of the intermediate fabric (18) is greater than 2 mm.

3. Mattress (10) according to one of the preceding claims, wherein the coating structure (14) includes an insulation fabric (20) interposed between the internal portion (12) and the intermediate fabric (18), said insulation fabric being waterproof.

4. Mattress (10) according to the preceding claim, wherein the insulation fabric (20) is breathable.

5. Mattress (10) according to one of the preceding claims, wherein the coating structure (14) includes a covering fabric (16), said covering fabric (16) being superior to the intermediate fabric (18) and having hygroscopic properties.

6. Mattress (10) according to claim 1, wherein the coating structure (14) includes at least one transverse microduct (24) that develops in the coating structure (14) in the direction of minimum length of the mattress.

7. Mattress (10) according to claim 6, wherein the at least one transverse microduct (24) is orthogonal to the at least one longitudinal microduct (22).

8. Mattress (10) according to one of the preceding claims, wherein the coating structure (14) comprises at least one portion including a woolen fabric.

Patentansprüche

1. Matratze (10), die geeignet ist, die Wärmeregulierung und die Transpiration des Körpers eines auf der Matratze liegenden Benutzers zu gewährleisten, um einen hohen Ruhekomfort für den Benutzer zu garantieren, wobei die Matratze einen inneren Teil (12) mit Stützfunktion für den Körper des Benutzers und eine Beschichtungsstruktur (14) umfasst, die auf der Außenfläche des inneren Teils (12) angeordnet und geeignet ist, mit dem Körper des Benutzers in Kontakt zu kommen, wobei die Beschichtungsstruktur (14) ein Zwischengewebe (18) mit einer alveolengängigen Struktur mit transpirierenden und hygroskopischen Eigenschaften umfasst, wobei die Be-

- schichtungsstruktur (14) mindestens einen wasser-durchlässigen Mikrokanal (22, 24) umfasst, der geeignet ist, Wasser von der Oberfläche der Matratze zu absorbieren und zu transportieren; **gekennzeichnet durch** die Tatsache, dass die Beschichtungsstruktur (14) mindestens einen länglichen Mikrokanal (22) aufweist, der sich in der Beschichtungsstruktur (14) in Richtung der maximalen Länge der Matratze entwickelt.
2. Matratze (10) nach dem vorhergehenden Anspruch, wobei die Dicke des Zwischengewebes (18) mehr als 2 mm beträgt.
 3. Matratze (10) nach einem der vorhergehenden Ansprüche, wobei die Beschichtungsstruktur (14) ein Isoliergewebe (20) umfasst, das zwischen dem inneren Teil (12) und dem Zwischengewebe (18) angeordnet ist, wobei das Isoliergewebe wasserdicht ist.
 4. Matratze (10) nach dem vorhergehenden Anspruch, wobei der Isolationsstoff (20) atmungsaktiv ist.
 5. Matratze (10) nach einem der vorhergehenden Ansprüche, wobei die Beschichtungsstruktur (14) ein Abdeckgewebe (16) umfasst, wobei das Abdeckgewebe (16) dem Zwischengewebe (18) überlegen ist und hygroskopische Eigenschaften aufweist.
 6. Matratze (10) nach Anspruch 1, wobei die Beschichtungsstruktur (14) mindestens einen quer verlaufenden Mikrokanal (24) aufweist, der sich in der Beschichtungsstruktur (14) in Richtung der Mindestlänge der Matratze entwickelt.
 7. Matratze (10) nach Anspruch 6, wobei der mindestens eine quer verlaufende Mikrokanal (24) orthogonal zu dem mindestens einen längs verlaufenden Mikrokanal (22) verläuft.
 8. Matratze (10) nach einem der vorhergehenden Ansprüche, wobei die Beschichtungsstruktur (14) mindestens einen Teil umfasst, der ein Wollgewebe enthält.
- revêtement (14) comprend un tissu intermédiaire (18) ayant une structure alvéolaire avec des propriétés transpirantes et hygrosco-piques, dans laquelle la structure de revêtement (14) comprend au moins un microconduit (22, 24), perméable à l'eau, qui est adapté pour absorber l'eau de la surface du matelas et la transporter ; **caractérisé par le fait que** la structure de revêtement (14) comprend au moins un microconduit longitudinal (22) qui se développe dans la structure de revêtement (14) dans la direction de la longueur maximale du matelas.
2. Matelas (10) selon la revendication précédente, dans lequel l'épaisseur du tissu intermédiaire (18) est supérieure à 2 mm.
 3. Matelas (10) selon l'une des revendications précédentes, dans lequel la structure de revêtement (14) comprend un tissu isolant (20) interposé entre la partie interne (12) et le tissu intermédiaire (18), ledit tissu isolant étant imperméable.
 4. Matelas (10) selon la revendication précédente, dans lequel le tissu isolant (20) est respirant.
 5. Matelas (10) selon l'une des revendications précédentes, dans lequel la structure de revêtement (14) comprend un tissu de recouvrement (16), ledit tissu de recouvrement (16) étant supérieur au tissu intermédiaire (18) et ayant des propriétés hygrosco-piques.
 6. Matelas (10) selon la revendication 1, dans lequel la structure de revêtement (14) comprend au moins un microconduit transversal (24) qui se développe dans la structure de revêtement (14) dans la direction de la longueur minimale du matelas.
 7. Matelas (10) selon la revendication 6, dans lequel le au moins un microconduit transversal (24) est orthogonal au au moins un microconduit longitudinal (22).
 8. Matelas (10) selon l'une des revendications précédentes, dans lequel la structure de revêtement (14) comprend au moins une partie incluant un tissu de laine.

Revendications

1. Matelas (10) apte à assurer la thermorégulation et la transpiration du corps d'un utilisateur couché sur le matelas afin de garantir un confort élevé pour l'utilisateur au repos, le matelas comprenant une partie interne (12) ayant une fonction de soutien pour le corps de l'utilisateur, et une structure de revêtement (14) disposée sur la surface externe de la partie interne (12) et adaptée pour entrer en contact avec le corps de l'utilisateur, dans laquelle la structure de

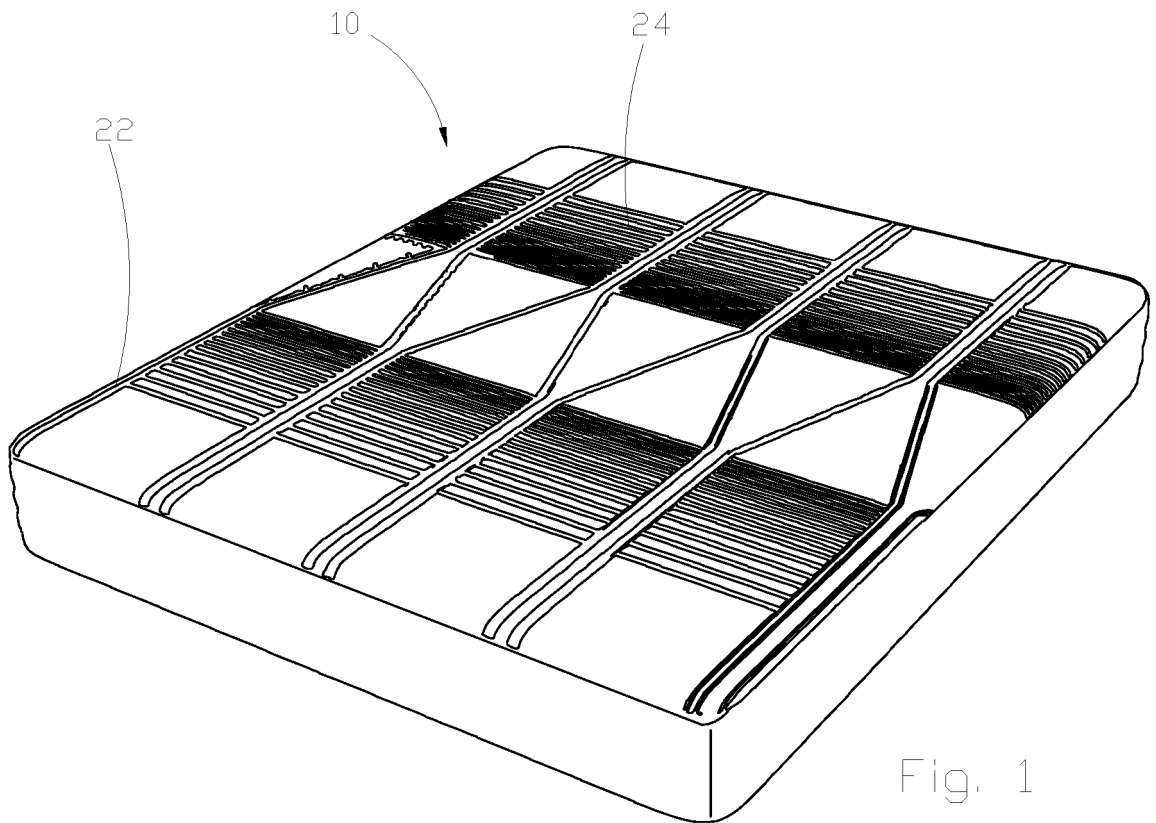

Fig. 1

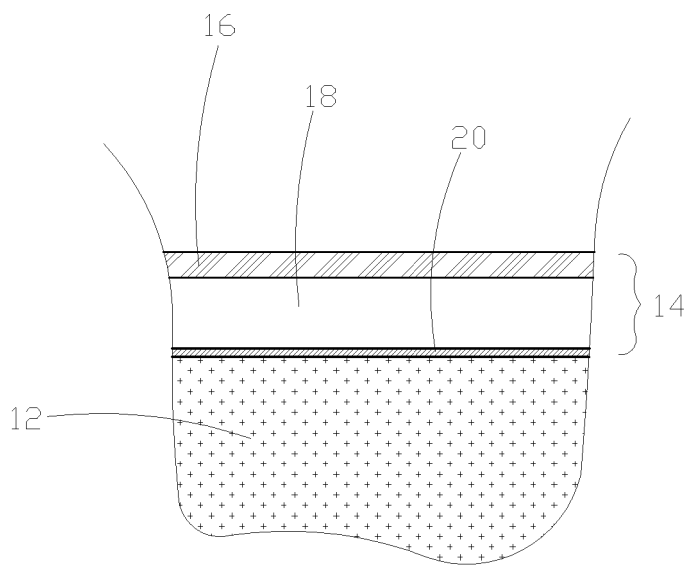

Fig. 2

REFERENCES CITED IN THE DESCRIPTION

This list of references cited by the applicant is for the reader's convenience only. It does not form part of the European patent document. Even though great care has been taken in compiling the references, errors or omissions cannot be excluded and the EPO disclaims all liability in this regard.

Patent documents cited in the description

- US 2006189955 A1 [0001]
- WO 0111127 A1 [0001]
- US 2017079444 A1 [0001]