

**(19) AUSTRALIAN PATENT OFFICE**

- (54) Title  
Device for connecting a bone fixation element to a longitudinal rod
- (51) <sup>6</sup> International Patent Classification(s)  
A61B 017/70
- (21) Application No: 2000264233 (22) Application Date: 2000.08.24
- (87) WIPO No: W002/15806
- (43) Publication Date : 2002.03.04  
(43) Publication Journal Date : 2002.05.30
- (71) Applicant(s)  
Synthes AG Chur
- (72) Inventor(s)  
Frigg, Robert; Donath, Raoul7
- (74) Agent/Attorney  
Phillips Ormonde & Fitzpatrick, Level 21 367 Collins Street,  
Melbourne, VIC, 3000
- (56) Related Art  
FR 2794962  
US 5487744  
US 5474551

(12) NACH DEM VERTRAG ÜBER DIE INTERNATIONALE ZUSAMMENARBEIT AUF DEM GEBIET DES PATENTWESENS (PCT) VERÖFFENTLICHTE INTERNATIONALE ANMELDUNG

(19) Weltorganisation für geistiges Eigentum  
Internationales Büro



(43) Internationales Veröffentlichungsdatum  
28. Februar 2002 (28.02.2002)

PCT

(10) Internationale Veröffentlichungsnummer  
WO 02/15806 A1

- (51) Internationale Patentklassifikation: **A61B 17/70** (71) **Anmelder** (nur für CA): **SYNTHES (U.S.A.)** [US/US]; 1690 Russell Road, P.O. Box 1766, Paoli, PA 19301-1222 (US).
- (21) Internationales Aktenzeichen: PCT/CH00/0049 (72) **Erfinder; und**
- (22) Internationales Anmeldedatum: 24. August 2000 (24.08.2000) (75) **Erfinder/Anmelder** (nur für US): **FRIGG, Robert** [CH/CH]; Maitenweg 8, CH-2544 Beilbach (CH). **DO-NATTI, Raoul** [DI/DI]; Lörracherstrasse 27 I, D-79739 Grenzach-Wyhlen (DE).
- (25) Einreichungssprache: Deutsch (74) **Anwalt: LUSUARDI, Werther**; Dr. Lusuardi AG, Kreuzbühlstrasse 8, CH-8008 Zürich (CH).
- (26) Veröffentlichungssprache: Deutsch (81) **Bestimmungsstaaten** (national): AU, BR, CA, CN, ID, IN, JP, KR, MX, NZ, US, ZA.
- (71) **Anmelder** (für alle Bestimmungsstaaten mit Ausnahme von CA, US): **SYNTHES AG CHUR** [CH/CH]; Grabenstrasse 15, CH-7002 Chur (CH).

[Fortsetzung auf der nächsten Seite]

(54) Title: DEVICE FOR CONNECTING A BONE FIXATION ELEMENT TO A LONGITUDINAL ROD

(54) Bezeichnung: VORRICHTUNG ZUR VERBINDUNG EINES KNOCHENFIXATIONSELEMENTES MIT EINEM LÄNGSSTAB



WO 02/15806 A1

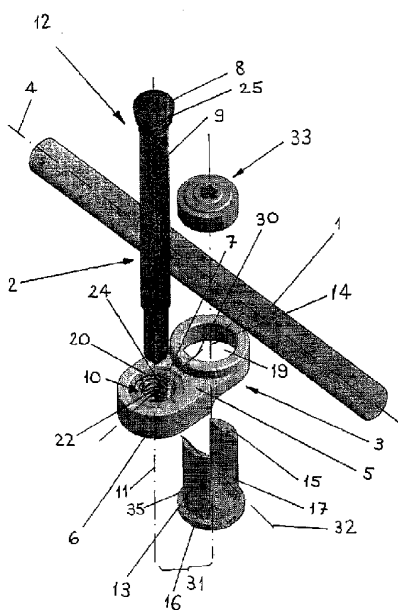

(57) **Abstract:** The invention relates to a device for joining a bone fixation element to a longitudinal rod. Said device comprises: A) a plate-shaped transversal connector (3) with a plate top side (5) for placing against a longitudinal rod (1) and with a cavity (7) that passes through said transversal connector (3); B) a clamping jaw (10), which can be resiliently compressed and which can be accommodated inside the cavity (7), and; C) a tightening means (12), which is provided for radially spreading the clamping jaw (10) inside the cavity (7), whereby; D) the transversal connector (3) comprises a boring (19), which passes through the transversal connector (3) from the plate top side (5) to the plate bottom side (6) and which is located at a distance (31) from the cavity (7). The inventive device also comprises: E) a longitudinal rod connector (13), which can be accommodated inside the boring (19) and which is provided with a channel (17) for accommodating a longitudinal rod (1), and; F) fixing means (33) for detachably fixing a longitudinal rod (1) that can be inserted into the channel (17), and for detachably fixing the longitudinal rod connector (13) with regard to the transversal connector (3), and such that; G) when the fixing means (33) is loosened, the transversal connector (3) is arranged in a manner that permits it to rotate with the longitudinal rod connector (13) about the central axis (14).

(57) **Zusammenfassung:** Vorrichtung zur Verbindung eines Knochenfixationselementes mit einem Längsstab, welche A) einen plattenförmigen Querverbinder (3) mit einer Plattenoberseite (5) zur Anlage an einen Längsstab (1) und einem den Querverbinder (3) durchdringenden Hohlraum (7); B) eine im Hohlraum (7) aufnehmbare, elastisch komprimierbare Klemmbaue (10);

[Fortsetzung auf der nächsten Seite]



**(84) Bestimmungsstaaten** (regional): europäisches Patent (AT, BE, CH, CY, DE, DK, ES, FI, FR, GB, GR, IE, IT, LU, MC, NL, PT, SE).

Zur Erklärung der Zweibuchstaben-Codes und der anderen Abkürzungen wird auf die Erklärungen ("Guidance Notes on Codes and Abbreviations") am Anfang jeder regulären Ausgabe der PCT-Gazette verwiesen.

**Veröffentlicht:**  
mit internationalem Recherchenbericht

---

und C) ein Spannmittel (12), welches zur radialen Spreizung der Klemmbacke (10) im Hohlraum (7) dient, umfasst, wobei D) der Querverbinder (3) eine den Querverbinder (3) von der Plattenoberseite (5) zur Plattenunterseite (6) durchdringende, in einem Abstand (31) zum Hohlraum (7) angeordnete Bohrung (19) umfasst; D) die Vorrichtung einen in der Bohrung aufnehmbaren Längsstabverbinder (13) mit einem Kanal (17) zur Aufnahme eines Längsstabes (1); und E) Feststellmittel (33) zur lösbaren Fixierung eines in den Kanal (17) einlegbaren Längsstabes (1) sowie des Längsstabverbinders (13) relativ zum Querverbinder (3) umfasst, und dass F) der Querverbinder (3) bei gelösten Feststellmitteln (33) um die Zentralachse (14) drehbar mit dem Längsstabverbinder (13) angeordnet ist.

---

**Apparatus for connecting a bone fastener to a longitudinal rod**

The invention relates to an apparatus for connecting a bone fastener to a  
5 longitudinal rod.

In the posterior treatment of spinal deformities, pedicle screws or hooks  
are used in order to connect vertebral bodies to a longitudinal rod. Prior  
to its utilisation, the longitudinal rod is shaped in a particular form so as to  
10 compensate the deformity of the vertebral column. This technique has  
proved successful and meanwhile has come to be considered as state of  
the art.

Despite the development of new connecting techniques, such as the use  
15 of jaws with polyaxial bearings ensuring the connection between the  
screws and the longitudinal rod, the intra-operative connection of the two  
elements is problematic, particularly in cases of heavy spinal deformities.  
The reason for this is to be seen in the defined distance between the head  
of the pedicle screw and the longitudinal carrier. In other words, the  
20 polyaxial bearing of the screw head within the connecting jaw allows for  
variable screw directions but not for variable

---

distances between screw head and longitudinal carrier. Yet, a variable distance between the screw head or the end portion of the hook and the longitudinal carrier would often be desirable as it is not always possible to achieve a 100 percent alignment of the vertebral column relative to the longitudinal rod. Such systems allowing for a variable distance between the pedicle screws or hooks and the longitudinal carrier are known in the art.

10 An apparatus of this type for connecting pedicle screws which may be driven into vertebral pedicles to a longitudinal rod is disclosed, for example, in US 5,474,551 FINN. The coupler assembly comprises a longitudinal rod coupler for connecting a transverse coupler to the  
15 longitudinal rod, the transverse coupler being displaceable relative to the longitudinal rod in the directions of the axes of the longitudinal rod and of the transverse coupler, said axes extending vertically to each other. The pedicle screw is polyaxially pivotably connected to the transverse  
20 coupler and is arranged in such a way on the transverse coupler that the longitudinal axis of the pedicle screw in its unpivoted position is vertical to the axis of the longitudinal rod and to the axis of the transverse coupler. This known apparatus suffers from the disadvantage that the  
25 distance between the pedicle screw or the pedicle hook and the longitudinal rod can be varied only unilaterally. With this unilaterally variable jaw, the longitudinal rod must have a defined position, extending either medially or laterally relative to the pedicle screw or the pedicle  
30 hook. The disadvantage of this resides in the fact that the distance necessary between individual pedicle screws or pedicle hooks and the longitudinal rod may be considerable

in order to enable a correction of the other pedicle screws or pedicle hooks.

The invention is intended to provide a remedy for this. It would therefore  
5 be desirable to create an apparatus for connecting a pedicle screw or a  
pedicle hook to a longitudinal rod which permits on the one hand a  
polyaxial bearing of the pedicle screw or pedicle hook and, on the other  
hand, allows a pivotable connection between the transverse coupler and  
the longitudinal rod, said connection being lockable in any desired  
10 position.

Broadly, the present invention provides an apparatus for connecting a  
bone fastener to a longitudinal rod, including: a plate-like transverse  
coupler with a longitudinal axis a top surface designed to be in contact  
15 with a longitudinal rod, a bottom surface, and a cavity penetrating the  
transverse coupler from the top surface to the bottom surface and  
extending coaxially to a first axis arranged essentially vertically to the  
longitudinal axis; a gripping jaw extending concentrically to a second axis  
which may be received in the cavity and is resiliently compressible  
20 vertically to the second axis for releasably fixating a bone fastener on the  
transverse coupler; and a tension means which serves for radially  
spreading apart the gripping jaw and thus for releasably fixating a bone  
fastener within the cavity. The transverse coupler includes a bore  
penetrating the transverse coupler from the top surface to the bottom  
25 surface and arranged coaxially to a central axis intersecting the  
longitudinal axis at a distance from the first axis and extending essentially  
parallel to the first axis. The apparatus further includes a longitudinal rod  
coupler which may be received in the bore in such a way that it extends  
coaxially to the central axis and which includes a channel with a third axis

---

---

3a

extending essentially vertically to the central axis wherein a longitudinal rod may be received; and blocking means for releasably fixating, relative to the transverse coupler, a longitudinal rod insertable in such a way into the channel that it extends coaxially or parallel to the third axis, and the  
5 longitudinal rod coupler. With the blocking means released, the transverse coupler is in rotatable engagement with the longitudinal rod coupler.

Thus, the apparatus according to the invention comprises essentially a  
10 plate-like transverse coupler with a top surface designed for being in contact with the longitudinal rod, a bottom surface, and a cavity penetrating the transverse coupler from the top surface to the bottom surface and extending concentrically to a first axis which serves for receiving a radially resiliently deformable gripping jaw. By means of this  
15 resiliently deformable gripping jaw and of a tension means serving for resiliently spreading apart the gripping jaw, the bone fastener is releasably connectable to the transverse coupler. In addition, the apparatus according to the invention comprises an essentially cylindrical longitudinal rod coupler displaceable on the longitudinal rod coaxially to the axis of  
20 said rod, having a central axis extending vertically to the axis of the rod, a top end portion intersecting the central axis, and a bottom end portion

---

intersecting the central axis, as well as a channel  
extending vertically to the central axis and penetrating  
the longitudinal rod coupler for receiving the longitudinal  
rod, and a blocking means which consists, for example, of a  
5 screw cap and may be screwed over the top end portion of  
the longitudinal rod coupler coaxially to the central axis,  
so that by means of the longitudinal rod coupler and the  
screw cap the transverse coupler and the longitudinal rod  
may be releasably fixated relative to each other. At a  
10 distance from the cavity, the transverse coupler comprises  
a through bore, extending from the top surface to the  
bottom surface, for receiving the longitudinal rod coupler  
in such a way that the latter is rotatable about the  
central axis, so that the transverse coupler is pivotable  
15 relative to the axis of the longitudinal rod when the screw  
cap is released.

In a preferred embodiment of the apparatus according to the  
invention, the top surface of the transverse coupler is  
20 offset so that the gripping jaw with a bone fastener  
inserted therein and with tension means is recessed with  
respect to the longitudinal rod to such an extent that the  
transverse coupler is rotatable by 360 degrees relative to  
the axis of the longitudinal rod, even if the second axis  
25 of the gripping jaw is at its maximally pivoted position  
relative to the first axis of the cavity.

Preferably, the cavity is shaped in the form of a spherical  
segment between two parallel circles extending axially  
30 symmetrically to the first axis, whereas the gripping jaw  
has a form complementary to that of the cavity and extends  
along a second axis. The gripping jaw comprises a top end  
surface intersecting the second axis and a conical bore

---

extending concentrically to the second axis and including a conical internal screw thread, said bore having a tapered form and penetrating the gripping jaw from the top end face. The tension means is shaped in a frustoconical form  
5 complementary to the conical bore and is equipped with a conical, external screw thread, so that by screwing the tension means into the conical, internal screw thread the gripping jaw is radially spread apart and thus pressed against the wall of the cavity.

10

In one embodiment of the apparatus according to the invention, the gripping jaw forms the head portion of a bone fastener, in particular a pedicle hook, and is realised integral therewith, which permits to obtain a  
15 simple layout of the apparatus.

In another embodiment of the apparatus according to the invention, said head portion is formed by a tension means shaped in a frustoconical form provided with a conical,  
20 external screw thread and is realised integral with the bone fastener, in particular a pedicle screw. This configuration also permits to obtain a simple layout of the apparatus according to the invention.

25 In a further embodiment of the apparatus according to the invention, the longitudinal rod coupler comprises a conical flange located in its bottom end portion which widens towards said bottom end portion in such a way that it may become wedged in a complementary inner cone formed in the  
30 bore on the bottom surface of the transverse coupler. Thus, the transverse coupler may be secured against twisting relative to the longitudinal rod coupler.

---

The conical flange may comprise a radial tothing, permitting the longitudinal rod coupler and the transverse coupler to be additionally secured against twisting relative to each other.

5

In yet another embodiment of the apparatus according to the invention, the longitudinal rod coupler comprises a recess which rests on the top surface of the transverse coupler once the elements have been put together, which prevents  
10 the longitudinal rod coupler, as the apparatus is being implanted, from falling out of the bore formed in the transverse coupler.

Further advantageous embodiments of the invention are  
15 characterised in the dependent claims.

The advantages achieved by the present invention consist basically in the fact that the apparatus according to the invention makes it possible to establish a connection  
20 between the gripping jaw with the pedicle screw or the pedicle hook and the longitudinal rod, which permits a rotation of the gripping jaw relative to the axis of the longitudinal rod. Due to the design of the transverse coupler, characterised by an offset connection between  
25 transverse coupler and gripping jaw as compared to the connection between longitudinal rod and transverse coupler, a rotation of the gripping jaw by 360 degrees relative to the axis of the longitudinal rod is possible. The transverse coupler may be firmly kept in place in any  
30 desired position relative to the longitudinal rod. Once the correction of the vertebral column has been achieved, the bone fastener, i.e. for example the pedicle screw or the pedicle hook, may be located laterally, medially or

immediately beneath the longitudinal rod. Thus, with unchanged implant dimension, the possible distance for correction may be doubled, as compared to a unilaterally displaceable gripping jaw.

5

In the following, the invention and further developments of the invention will be illustrated in greater detail with reference to the partially diagrammatic representations of several embodiments.

10

In the drawings:

Fig. 1 is an exploded view of the preferred embodiment of the apparatus according to the invention;

15

Fig. 2 is a sectional view of one embodiment of the apparatus according to the invention;

Fig. 3 is a sectional view of another embodiment of the apparatus according to the invention; and

20

Fig. 4 is a sectional view of a further embodiment of the apparatus according to the invention;

25 Fig. 1 shows a preferred embodiment of the apparatus according to the invention comprising basically a plate-like transverse coupler 3, a gripping jaw 10 including a tension means 12 for releasably fixating a bone fastener 2, which, as shown in the present example, may be a bone  
30 screw, and a longitudinal rod coupler 13 with blocking means 33 for releasably fixating a longitudinal rod 1 on the transverse coupler 3. The transverse coupler 3 is provided with a longitudinal axis 30, a top surface 5

---

designed to be in contact with the longitudinal rod 1, a bottom surface 6, and a cavity 7 penetrating the transverse coupler 3 from the top surface 5 to the bottom surface 6 and extending coaxially to a first axis 11 arranged essentially vertically to the longitudinal axis 30. In addition, the transverse coupler 3 comprises a bore 19 penetrating the transverse coupler 3 from the top surface 5 to the bottom surface 6 and extending coaxially to a central axis 14 arranged on the longitudinal axis 30 at a distance 31 from the first axis 11 and extending essentially parallel to the first axis 11, said bore 19 serving for receiving the longitudinal rod coupler 13 in such a way that it is rotatable about the central axis 14. The gripping jaw 10 is formed concentrically to a second axis 22. The cavity 7 in the present embodiment is shaped in the form of a spherical segment between two parallel circles extending symmetrically to the first axis 11, whereas the gripping jaw 10 is shaped in the form of a complementary spherical segment, so that the gripping jaw 10 may be received in the cavity 7 in such a way that it is pivotable about the first axis 11 as well as about two pivot axes extending vertically thereto and that it is radially resiliently compressible so as to be capable of releasably fixating a bone fastener 2 on the transverse coupler 3. The tension means 12, which serves for radially spreading apart the gripping jaw 10 and thus for releasably fixating a bone fastener 2 within the cavity 7, forms the head portion 8 of the bone fastener 2 shaped in the form of a bone screw and is realised integral with the bone fastener 2. The gripping jaw 10 comprises a top end face 20 intersecting the second axis 22 and a conical bore 23 extending concentrically to the second axis 22 and including a conical internal screw thread 24 which

penetrates the gripping jaw 10 from the top end face 20 so that a tension means 12 shaped in a frustoconical form complementary to the conical bore 23 and equipped with a conical external screw thread 25 may be driven into the conical bore 23, which causes the gripping jaw 10 to be radially spread apart. If for example the tension means 12 is formed by the head portion 8 of a bone fastener 2 realised in the form of a bone screw, said bone screw is releasably fixated on the transverse coupler 3 by screwing the head portion 8 into the gripping jaw 10. For receiving the longitudinal rod 1, a longitudinal rod coupler 13 is used which may be received in the bore 19 in such a way that it extends coaxially to the central axis 14 and which includes a channel 17 having a third axis 32 extending essentially vertically to the central axis 14 wherein the longitudinal rod 1 may be received. The longitudinal rod coupler 13 comprises a top end portion 15 intersecting the central axis 14 and a bottom end portion 16 intersecting the central axis 14 including a flange 35 apt to be fitted on the bottom surface 6 of the plate-like transverse coupler. The channel 17 is open towards the top end portion 15 of the longitudinal rod coupler 13. For releasably fixating the longitudinal rod 1, the apparatus according to the invention comprises blocking means 33 which in the present embodiment are shaped in the form of a screw cap 18 (Fig. 2) which may be screwed over an external screw thread 34 (Fig. 2) arranged on the top end portion 15 of the longitudinal rod coupler 13, whereby the longitudinal rod 1 inserted in the channel 17 parallel to the third axis 32 and the longitudinal rod coupler 13 may be releasably fixated relative to the transverse coupler 3. When the blocking means 33 are released, the transverse coupler 3 is in rotatable engagement with the longitudinal rod coupler

13. The top surface 5 of the transverse coupler 3 is offset so that the gripping jaw 10 with the head portion 8 of a bone fastener 2 inserted therein and with tension means 12 is recessed to such an extent with respect to the longitudinal rod 1 that the transverse coupler 3 is rotatable by 360 degrees relative to the rod axis 4 of a longitudinal rod 1 insertable into the channel 17.

The embodiment of the apparatus according to the invention shown in Fig. 2 differs from the embodiment shown in Fig. 1 only in so far as the gripping jaw 10 forms the head portion 8 of a bone fastener 2 shaped in the form of a bone screw and as it is realised integral with said bone screw. In addition, the longitudinal rod coupler 13 comprises a conical flange 26 located in its bottom end portion 16 which widens towards said bottom end portion 16 in such a way that it may become wedged in a complementary inner cone 27 formed in the bore 19 on the bottom surface 6 of the transverse coupler 3. A recess 29 is provided on the longitudinal rod coupler 13 which rests on the top surface 5 of the transverse coupler 3 once the two elements have been put together. The mounting of the longitudinal rod coupler 13 is enabled by a slot 36 extending axially and permitting the recess 29 to be radially compressed to such an extent that the longitudinal rod coupler 13 may be inserted from the bottom surface 6 into the bore 19.

Fig. 3 shows an embodiment of the apparatus according to the invention which differs from the embodiment shown in Fig. 2 only in so far as the bone fastener 2 is realised in the form of a pedicle hook instead of a bone screw.

Fig. 4 shows an embodiment of the apparatus according to the invention which differs from the embodiment described under Fig. 1 in so far as, seen in a direction vertical to the central axis 14, the channel 17 is open towards the contact surface of the longitudinal rod coupler 13. This permits the longitudinal rod 1 to be inserted laterally into the longitudinal rod coupler 13. In order to laterally fixate the longitudinal rod 1 relative to the longitudinal rod coupler 13, a sleeve 36 including two side walls 37 extending parallel to the central axis 14 is placed over the longitudinal rod coupler 13 from the top end portion 15 and firmly kept in place by means of a nut 38 which may be screwed over the external screw thread 34. Thus the longitudinal rod 1 is kept in place between the top surface 5 of the plate-like transverse coupler and the sleeve 36, whereas the side walls 37 permit a lateral fixation. In addition, the conical flange 26 is provided with a radial tothing 28 whereby the longitudinal rod coupler 13 and the transverse coupler 3 are secured against twisting about the central axis 3.

THE CLAIMS DEFINING THE INVENTION ARE AS FOLLOWS:

1. An apparatus for connecting a bone fastener to a longitudinal rod,  
5 including:  
a plate-like transverse coupler with a longitudinal axis a top surface  
designed to be in contact with a longitudinal rod, a bottom surface, and a  
cavity penetrating the transverse coupler from the top surface to the  
bottom surface and extending coaxially to a first axis arranged essentially  
10 vertically to the longitudinal axis;  
a gripping jaw extending concentrically to a second axis which may  
be received in the cavity and is resiliently compressible vertically to the  
second axis for releasably fixating a bone fastener on the transverse  
coupler; and  
15 a tension means which serves for radially spreading apart the  
gripping jaw and thus for releasably fixating a bone fastener within the  
cavity;  
wherein the transverse coupler includes a bore penetrating the  
transverse coupler from the top surface to the bottom surface and  
20 arranged coaxially to a central axis intersecting the longitudinal axis at a  
distance from the first axis and extending essentially parallel to the first  
axis;  
wherein the apparatus includes a longitudinal rod coupler which  
may be received in the bore in such a way that it extends coaxially to the  
25 central axis and which includes a channel with a third axis extending  
essentially vertically to the central axis wherein a longitudinal rod may be  
received; and

W:\Georgij\PWG Spec\68823.doc

blocking means for releasably fixating, relative to the transverse coupler, a longitudinal rod insertable in such a way into the channel that it extends coaxially or parallel to the third axis, and the longitudinal rod coupler,  
5 and

wherein, with the blocking means released, the transverse coupler is in rotatable engagement with the longitudinal rod coupler.

2. An apparatus as claimed in claim 1, wherein the top surface of the  
10 transverse coupler is offset so that the gripping jaw with the head portion of a bone fastener inserted therein and with tension means is recessed with respect to the longitudinal rod to such an extent that the transverse coupler is rotatable by 360 degrees relative to the rod axis of a longitudinal rod insertable into the channel.

15

3. An apparatus as claimed in claim 1 or 2, wherein the gripping jaw forms the head portion and wherein it is realised integral with the bone fastener.

4. An apparatus as claimed in claim 1 or 2, wherein the tension means  
20 forms the head portion and wherein it is realised integral with the bone fastener.

5. An apparatus as claimed in any of the claims 1 to 4, wherein the cavity  
25 is shaped in the form of a spherical segment between two parallel circles extending axially symmetrically to the first axis, the gripping jaw being shaped in the form of a complementary spherical segment, so that the gripping jaw is rotatable within the cavity about two axes extending vertically to the first axis and about the second axis.

30

6. An apparatus as claimed in claim 5, wherein the gripping jaw includes a top end face intersecting the second axis and a conical bore extending concentrically to the second axis and including a conical internal screw thread which penetrates the gripping jaw from the top end face, wherein the tension means is shaped in a frustoconical form complementary to the conical bore and is equipped with a conical external screw thread so that by screwing the tension means into the conical bore the gripping jaw may be radially spread apart.
- 5
- 10 7. An apparatus as claimed in any of the claims 1 to 5, wherein the longitudinal rod coupler includes a top end portion intersecting the central axis and a bottom end portion intersecting the central axis and wherein the channel is open towards the top end portion of the longitudinal rod coupler.
- 15
8. An apparatus as claimed in any of the claims 1 to 6, wherein the channel is open in a direction vertical to the central axis.
9. An apparatus as claimed in any of the claims 1 to 8, wherein the longitudinal rod coupler includes a conical flange located in its bottom end portion which widens towards said bottom end portion in such a way that it may become wedged in a complementary inner cone formed in the bore on the bottom surface of the transverse coupler.
- 20
- 25 10. An apparatus as claimed in claim 9, wherein the conical flange includes a radial toothing whereby the longitudinal rod coupler and the transverse coupler are secured against twisting.

11. An apparatus as claimed in any of the claims 1 to 10, wherein the longitudinal rod coupler includes a recess which rests on the top surface of the transverse coupler once the two elements have been put together.

5 12. An apparatus for connecting a bone fastener to a longitudinal rod substantially as herein described with reference to the accompanying drawings.

10

DATED: 20 May 2003

PHILLIPS ORMONDE & FITZPATRICK

Attorneys for:

SYNTHES AG CHUR

1/3

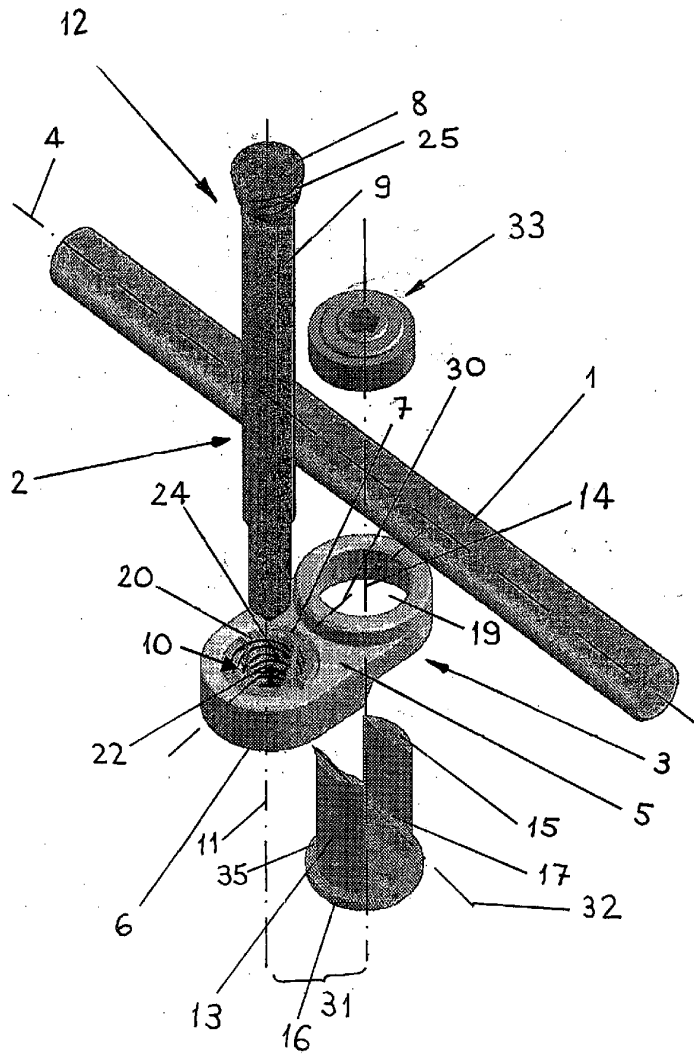

Fig. 1

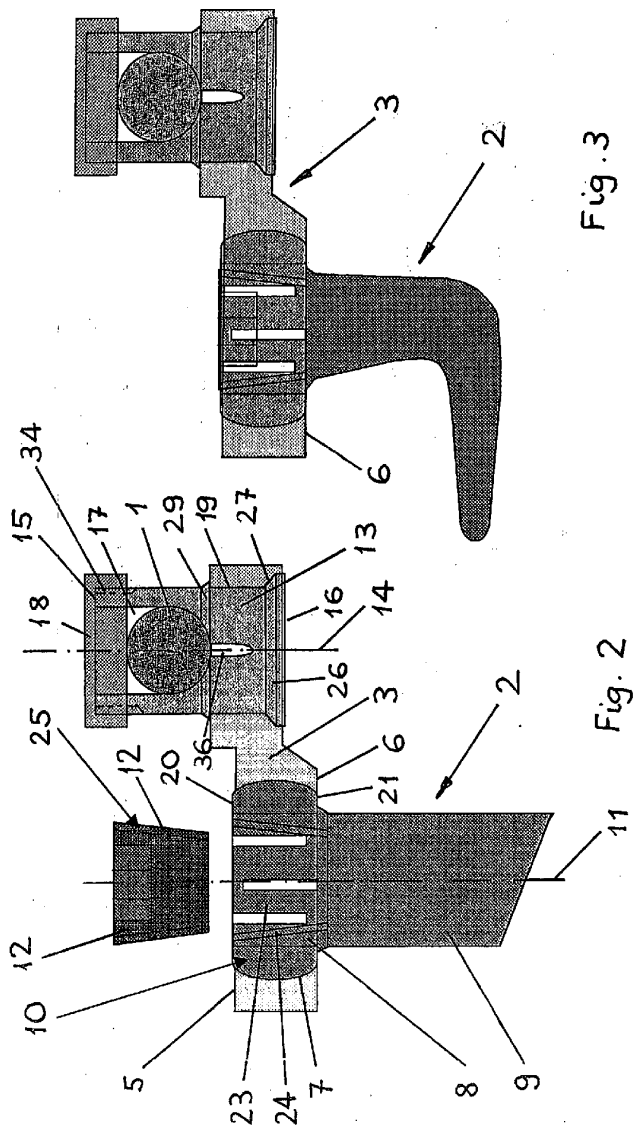

Fig. 3

Fig. 2

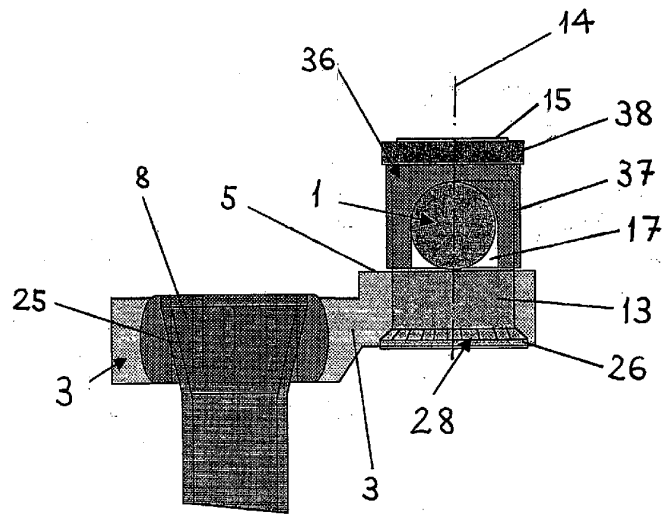

Fig. 4