

(12) INTERNATIONAL APPLICATION PUBLISHED UNDER THE PATENT COOPERATION TREATY (PCT)

(19) World Intellectual Property Organization  
International Bureau



(43) International Publication Date  
16 January 2003 (16.01.2003)

PCT

(10) International Publication Number  
**WO 03/005652 A1**

(51) International Patent Classification<sup>7</sup>: **H04L 12/56**,  
12/28

(21) International Application Number: PCT/US02/21095

(22) International Filing Date: 2 July 2002 (02.07.2002)

(25) Filing Language: English

(26) Publication Language: English

(30) Priority Data:  
60/306,438 6 July 2001 (06.07.2001) US  
10/143,134 10 May 2002 (10.05.2002) US

(71) Applicant: **INTERSIL AMERICAS INC.** [US/US];  
2401 Palm Bay Road NE, Mail Stop: 53-209, Palm Bay,  
FL 32905 (US).

(72) Inventors: **WEBSTER, Mark, A.**; 139 Island View Drive,  
Indian Harbour Beach, FL 32937 (US). **SEALS, Michael,  
J.**; 2288 Autumn Way, Melbourne, FL 32935 (US).

(74) Agent: **GARY, R., STANFORD**; 610 West Lynn, Austin,  
TX 78703 (US).

(81) Designated States (*national*): AE, AG, AL, AM, AT, AU,  
AZ, BA, BB, BG, BR, BY, BZ, CA, CH, CN, CO, CR, CU,  
CZ, DE, DK, DM, DZ, EC, EE, ES, FI, GB, GD, GE, GH,  
GM, HR, HU, ID, IL, IN, IS, JP, KE, KG, KP, KR, KZ, LC,  
LK, LR, LS, LT, LU, LV, MA, MD, MG, MK, MN, MW,  
MX, MZ, NO, NZ, OM, PH, PL, PT, RO, RU, SD, SE, SG,  
SI, SK, SL, TJ, TM, TN, TR, TT, TZ, UA, UG, UZ, VN,  
YU, ZA, ZM, ZW.

(84) Designated States (*regional*): ARIPO patent (GH, GM,  
KE, LS, MW, MZ, SD, SL, SZ, TZ, UG, ZM, ZW),  
Eurasian patent (AM, AZ, BY, KG, KZ, MD, RU, TJ, TM),  
European patent (AT, BE, BG, CH, CY, CZ, DE, DK, EE,  
ES, FI, FR, GB, GR, IE, IT, LU, MC, NL, PT, SE, SK,  
TR), OAPI patent (BF, BJ, CF, CG, CI, CM, GA, GN, GQ,  
GW, ML, MR, NE, SN, TD, TG).

**Published:**

- with international search report
- before the expiration of the time limit for amending the claims and to be republished in the event of receipt of amendments

*For two-letter codes and other abbreviations, refer to the "Guidance Notes on Codes and Abbreviations" appearing at the beginning of each regular issue of the PCT Gazette.*

(54) Title: WIRELESS COMMUNICATION SYSTEM CONFIGURED TO COMMUNICATE USING A MIXED WAVEFORM CONFIGURATION

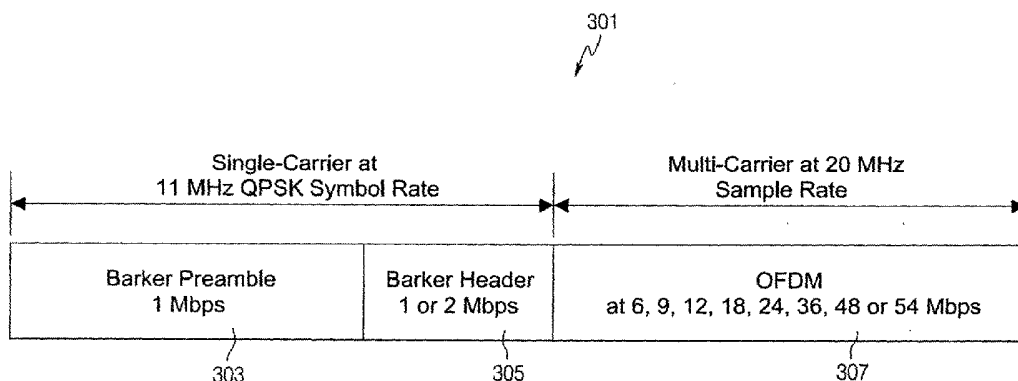

(57) Abstract: A wireless communication system 103 configured to communicate using a mixed waveform configuration 301. The mixed waveform includes a first portion 2101 modulated according to a single-carrier scheme with a preamble 303 and header 305 and a second portion 2103 modulated according to a multi-carrier scheme. The waveform is specified so that a CIR estimate obtainable from the first portion is reusable for acquisition of the second portion by the receiver. The transmitter 1601 may include first 1605 and second 1603 kernels and a switch 1607, where switch selects the first kernel for the first portion and the second kernel for the second portion to develop a transmit waveform. The receiver 201 may include a single-carrier receiver 207, a multi-carrier receiver 209, and a switch 205 that provides a first portion of a signal being received to the single-carrier receiver and a second portion of the signal being received to the multi-carrier receiver.



WO 03/005652 A1

**Title:** Wireless Communication System Configured to Communicate Using a Mixed Waveform Configuration

**Inventors:** Mark A. Webster and Michael J. Seals

**Field of the Invention:**

5 The present invention relates to wireless communications, and more particularly to a wireless communication system configured to communicate using a single-carrier to multi-carrier mixed waveform configuration.

**Background of the Invention:**

The Institute of Electrical and Electronics Engineers, Inc. (IEEE) 802.11  
10 standard is a family of standards for wireless local area networks (WLAN) in the unlicensed 2.4 and 5 Gigahertz (GHz) bands. The current 802.11b standard defines various data rates in the 2.4 GHz band, including data rates of 1, 2, 5.5 and 11 Megabits per second (Mbps). The 802.11b standard uses direct sequence spread spectrum (DSSS) with a chip rate of 11 Megahertz (MHz), which is a serial  
15 modulation technique. The 802.11a standard defines different and higher data rates of 6, 12, 18, 24, 36 and 54 Mbps in the 5 GHz band. It is noted that systems implemented according to the 802.11a and 802.11b standards are incompatible and will not work together.

A new standard is being proposed, referred to as 802.11g (the “802.11g  
20 proposal”), which is a high data rate extension of the 802.11b standard at 2.4 GHz. It is noted that, at the present time, the 802.11g proposal is only a proposal and is not yet a completely defined standard. Several significant technical challenges are presented for the new 802.11g proposal. It is desired that the 802.11g devices be able to communicate at data rates higher than the standard 802.11b rates in the 2.4 GHz band.  
25 In some configurations, it is desired that the 802.11b and 802.11g devices be able to coexist in the same WLAN environment or area without significant interference or

interruption from each other, regardless of whether the 802.11b and 802.11g devices are able to communicate with each other. It may further be desired that the 802.11g and 802.11b devices be able to communicate with each other, such as at any of the standard 802.11b rates.

5           A dual packet configuration for wireless communications has been previously disclosed in U.S. Patent Application entitled, "A Dual Packet Configuration for Wireless Communications", Serial Number 09/586,571 filed on June 2, 2000, which is hereby incorporated by reference in its entirety. This previous system allowed a single-carrier portion and an orthogonal frequency division multiplexing (OFDM) 10 portion to be loosely coupled. Loosely coupled meant that strict control of the transition was not made to make implementations simple by allowing both an existing single-carrier modem and an OFDM modem together with a simple switch between them with a minor conveyance of information between them (e.g., data rate and packet length). In particular, it was not necessary to maintain strict phase, frequency, 15 timing, spectrum (frequency response) and power continuity at the point of transition (although the power step would be reasonably bounded). Consequently, the OFDM system needed to perform an acquisition of its own, separate from the single-carrier acquisition, including re-acquisition of phase, frequency, timing, spectrum (including multi-path) and power (Automatic Gain Control [AGC]). A short OFDM preamble 20 following the single carrier was used in one embodiment to provide reacquisition.

An impairment to wireless communications, including WLANs, is multi-path distortion where multiple echoes (reflections) of a signal arrive at the receiver. Both the single-carrier systems and OFDM systems must include equalizers that are designed to combat this distortion. The single-carrier system designs the equalizer on

its preamble and header. In the dual packet configuration, this equalizer information was not reused by the OFDM receiver. Thus, the OFDM portion employed a preamble or header so that the OFDM receiver could reacquire the signal. In particular, the OFDM receiver had to reacquire the power (AGC), carrier frequency, carrier phase, equalizer and timing parameters of the signal.

Interference is a serious problem with WLANs. Many different signal types are starting to proliferate. Systems implemented according to the Bluetooth standard present a major source of interference for 802.11-based systems. The Bluetooth standard defines a low-cost, short-range, frequency-hopping WLAN. Preambles are important for good receiver acquisition. Hence, losing all information when transitioning from single-carrier to multi-carrier is not desirable in the presence of interference.

There are several potential problems with the signal transition, particularly with legacy equipment. The transmitter may experience analog transients (e.g., power, phase, filter delta), power amplifier back-off (e.g. power delta) and power amplifier power feedback change. The receiver may experience AGC perturbation due to power change, AGC perturbation due to spectral change, AGC perturbation due to multi-path effects, loss of channel impulse response (CIR) (multi-path estimate, loss of carrier phase, loss of carrier frequency, and loss of timing alignment.

20

**Summary of the Invention:**

A wireless communication system configured to communicate using a mixed waveform configuration is disclosed and includes a transmitter configured to transmit according to a mixed waveform configuration and a receiver configured to acquire and receive packets with a mixed waveform configuration. The mixed waveform includes a first portion modulated according to a single-carrier scheme with a preamble and header and a second portion modulated according to a multi-carrier scheme. The waveform is specified so that a channel impulse response (CIR) estimate obtainable from the first portion is reusable for acquisition of the second portion.

In one configuration, the transmitter maintains power, carrier phase, carrier frequency, timing, and multi-path spectrum between the first and second portions of the waveform. The transmitter may include first and second kernels and a switch. The first kernel modulates the first portion according to the single-carrier modulation scheme and the second kernel generates the second portion according to the multi-carrier modulation scheme. The switch selects the first kernel for the first portion and the second kernel for the second portion to develop a transmit waveform. In one embodiment, the first kernel operates at a first sample rate and the second kernel operates at a second sample rate. The first kernel may employ a single-carrier spectrum that resembles a multi-carrier spectrum of the multi-carrier modulation scheme.

The first kernel may employ a time shaping pulse that is specified in continuous time. The time shaping pulse may be derived by employing an infinite impulse response of a brick wall approximation that is truncated using a continuous-

time window that is sufficiently long to achieve desired spectral characteristics and sufficiently short to minimize complexity. The first kernel may sample the time shaping pulse according to a Nyquist criterion. The average output signal power of the first kernel and the average output signal power of the second kernel may be maintained substantially equal. The first kernel may employ a first sample rate clock while the second kernel employs a second sample rate clock. In this latter case, the first and second sample rate clocks are aligned at predetermined timing intervals. Also, a first full sample of the multi-carrier modulation scheme begins one timing interval after the beginning of a last sample of the single-carrier modulation scheme.

10           The single-carrier signal from the first kernel may be terminated according to a windowing function specified for OFDM signal shaping defined in the 802.11a standard. The carrier frequency may be coherent between the first and second kernels. The carrier phase may be coherent between the first and second kernels. In one embodiment to achieve coherent phase, carrier phase of the second kernel multi-carrier signal is determined by carrier phase of a last portion of the second kernel single-carrier signal. The carrier phase of the second kernel multi-carrier signal may further be rotated by a corresponding one of a plurality of rotation multiples, each rotation multiple corresponding to one of a plurality of predetermined phases of the last portion of the second kernel single-carrier signal. In a particular embodiment, the first kernel single-carrier modulation scheme is according to 802.11b Barkers in which each Barker word is one of first, second, third and fourth possible phases and the second kernel multi-carrier modulation scheme is according to OFDM as defined in Annex G of the 802.11a standard. In this case, the OFDM symbols are rotated by the second kernel by zero if the last Barker word has the first phase, by 90 degrees if

the last Barker word has the second phase, by 180 degrees if the last Barker word has the third phase, and by  $-90$  degrees if the last Barker word has the fourth phase.

The requisite fidelity of the entire mixed waveform configuration may be specified by a requisite fidelity specified for the multi-carrier scheme. In one  
5 embodiment, the requisite fidelity is a function of data rate of the second portion and is determined by mean-squared-error normalized by signal power as specified for OFDM in the 802.11a standard.

The symbol rate clock and carrier frequency of the waveform may be derived from the same reference clock. The part per million (PPM) error of a clock  
10 fundamental for symbol rate and PPM error of a clock fundamental for carrier frequency may be substantially equal.

The receiver may include a single-carrier receiver, a multi-carrier receiver, and a switch that provides a first portion of a signal being received to the single-carrier receiver and that provides a second portion of the signal being received to the multi-  
15 carrier receiver. The single-carrier receiver acquires a first portion of an incoming signal including the preamble and header and determines a CIR estimate, and the multi-carrier receiver uses the CIR estimate for a second portion of the incoming signal. In a specific configuration, the single-carrier receiver programs taps of the first equalizer based on the CIR estimate, the multi-carrier receiver includes a second  
20 equalizer, and the multi-carrier receiver modifies taps of the second equalizer based on the CIR estimate determined by the first equalizer.

**Brief Description of the Drawings:**

A better understanding of the present invention can be obtained when the following detailed description of the preferred embodiment is considered in conjunction with the following drawings, in which:

5 Figure 1 is a block diagram of a WLAN system including four devices operating within the same room or area, where two of the devices are implemented according to the 802.11b standard and the other two are implemented according to the 802.11g proposal.

10 FIG. 2 is a block diagram of a mixed signal receiver implemented according to an embodiment of the present invention that may be used in either or both of the high rate devices of FIG. 1.

FIG. 3 is a conceptual diagram of a mixed signal packet implemented according to an embodiment of the present invention.

15 FIGs 4A and 4B are graph diagrams of plots of the spectrum of the 802.11b Barker chips and the 802.11a OFDM, respectively.

FIGs 5A and 5B are graph diagrams of time domain plots of the 802.11b QPSK Barker chips and the 802.11a OFDM, respectively, illustrating that the waveforms are radically different.

20 FIGs 6A is a graph diagram of a plot of the power spectral density (PSD) of a single sub-carrier out of the possible 64 possible sub-carriers defined in the 802.11a standard.

FIG. 6B is a graph diagram of a plot of the composite PSD of the 52 non-zero sub-carriers used in 802.11a.

25 FIG. 7A is a graph diagram of a plot of an exemplary "brickwall" double-sided spectrum centered at 0 MHz.



FIG. 7B is a graph diagram of a portion of the associated infinite-duration time response corresponding to the brickwall spectrum of FIG. 7A.

FIG. 8 is a graph diagram of a plot of an exemplary continuous-time window, which is a continuous time version of a Hanning window.

5 FIG. 9 is a graph diagram of a plot of the Hanning window of FIG. 8 overlaid with the portion of the infinite-duration time response corresponding to the brickwall spectrum of FIG. 7A.

FIG. 10 is a graph diagram of a plot of the exemplary pulse  $p(t)$  resulting from the overlaying illustrated in FIG. 9 and truncated to approximately 0.8  $\mu$ s.

10 FIG. 11 is a graph diagram of a plot of the spectral characteristics of the pulse  $p(t)$  illustrating that it is a close match to the OFDM spectrum.

FIG. 12 is a block diagram of an exemplary digital filter employed to architect a digital 22 MHz output sample rate using the continuous time pulse  $p(t)$ .

15 FIG. 13 is a graph diagram illustrating the sampling and polyphase decomposition of the continuous time pulse  $p(t)$  using the sampling scheme of FIG. 12.

FIG. 14 is a block diagram of another exemplary digital filter employed to architect a digital 20 MHz output sample rate using the pulse  $p(t)$ .

20 FIG. 15 is a graph diagram illustrating the sampling and polyphase decomposition of the continuous time pulse  $p(t)$  using the sampling scheme of FIG. 14.

FIG. 16 is a block diagram of a transmitter implemented according to an embodiment of the present invention.

25 FIG. 17 is a graph diagram comparing the 11 MHz Barker chip clock versus the 20 MHz OFDM sample clock.

FIG. 18 is a conceptual graph diagram illustrating alignment of the OFDM signal portion with the last Barker word of the header of the single-carrier portion.

FIG. 19 is a graph diagram illustrating normal OFDM symbol overlap.

FIG. 20 is a graph diagram illustrating exemplary 802.11a OFDM symbol onset and termination.

FIG. 21 is a graph diagram illustrating exemplary single-carrier termination, shaped consistent with 802.11a, and OFDM onset shaped identical to 802.11a.

FIG. 22A is a simplified graph diagram of a BPSK plot illustrating that BPSK incorporates both real and imaginary portions in two quadrants (1 of 2 phases).

FIG. 22B is a simplified graph diagram of a QPSK plot illustrating that QPSK incorporates both real and imaginary portions in all four quadrants (1 of 4 phases).

FIG. 23 is a graph diagram of a plot illustrating the phase of the last Barker word in the 802.11g header and the relative phase of the OFDM symbol in accordance with that described in Annex G of the 802.11a standard.

15

**Detailed Description of Embodiment(s) of the Invention:**

A configuration according to the present invention reuses the equalizer information obtained during acquisition of the single-carrier portion of the signal. In this manner, no OFDM preamble is required, although it still may be present for both convenience and fine tuning. The present disclosure describes a technique for providing complete continuity between the single-carrier and OFDM (multi-carrier) segments. This continuity is provided by specifying the transmit waveform completely for both the single-carrier and OFDM segments and specifying the transition. This enables complete continuity between the two signal segments, including AGC (power), carrier phase, carrier frequency, timing and spectrum (multi-path). In this manner, the signal does not have to be reacquired by the multi-path portion of the receiver since the information developed during the single-carrier portion (preamble/header) is valid and used to initiate capture of the multi-carrier portion. Maintaining and accumulating information makes the signal much more robust in the face of common interferences experience in wireless communications.

Figure 1 is a block diagram of a wireless local area network (WLAN) system operating within a particular room or area 101, including four WLAN devices 103, 105, 107 and 109 (103-109) are located within the area 101. The devices 103 and 105 are implemented according to at least one of several embodiments of the present invention with the 802.11g proposal in mind, whereas the devices 107 and 109 are implemented according to the 802.11b standard. All of the devices 103-109 operate in the 2.4 GHz band. The devices 103-109 may be any type of wireless communication device, such as any type of computer (desktop, portable, laptop, etc.), any type of compatible telecommunication device, any type of personal digital assistant (PDA), or any other type of network device, such as printers, fax machines,

scanners, hubs, switches, routers, etc. It is noted that the present invention is not limited to the 802.11g proposal, the 802.11b standard, the 802.11a standard or the 2.4 GHz frequency band, although these standards and frequencies may be utilized in certain embodiments.

5           The devices 107 and 109 communicate with each other at any of the standard 802.11b rates, including 1, 2, 5.5 and 11 Mbps. The devices 103 and 105 are mixed signal mode devices that communicate with each other at different or higher data rates using a mixed signal configuration according to any one of several embodiments, such as the standard 802.11a data rates of 6, 9, 12, 18, 24, 36, 48 or 54 Mbps.  
10   Alternative data rate groups are considered herein. The second group is advantageous as including two of the 802.11b standard data rates, namely 5.5 and 11 Mbps.

          In one or more first embodiments, the mixed signal devices 103-109 may operate or coexist in the same area 101 without significant interference from each other, where the devices 103, 105 communicate with each other at different or higher  
15   data rates than the 802.11b devices 107, 109. In the first embodiments, the devices 103, 105 may communicate with each other while the devices 107, 109 may communicate with each other, but the devices 103, 105 do not communicate with the devices 107, 109. In one or more second embodiments, at least one of the mixed  
20   signal devices 103, 105 is configured with a standard mode to be able to communicate with either of the devices 107, 109 at any one or more of the standard 802.11b data rates. In at least one third embodiment, the mixed signal devices 103, 105 communicate at different or higher data rates and are incompatible with the devices 107 and 109, so that the devices 103-109 are not able to coexist within the same area

101. The mixed signal devices 103, 105 may be implemented to operate in the 2.4 GHz band, although other frequency bands are contemplated.

In the first or second embodiments, it is desired that the devices 103 and 105 be able to communicate with each other without interruption or interference from either of the devices 107 and 109. This presents a significant technical challenge since the devices 103, 105 operate at different data rates when communicating with each other. The present invention solves this problem by enabling the devices 103 and 105 to be implemented to be able to communicate with each other at different or at higher data rates while residing in a same area 101 as the 802.11b devices 107, 109. Further, in the second embodiments the devices 103, 105 may also communicate with either of the devices 107, 109 at the 802.11b data rates.

FIG. 2 is a block diagram of a mixed signal receiver 201 implemented according to an embodiment of the present invention that may be used in either or both of the devices 103, 105. The incoming signal is received by an automatic gain control (AGC) 203 that adjusts receive power and provides a corresponding signal to a switch 205. The switch 205 initially provides the received signal to a single-carrier receiver 207. The single-carrier receiver 207 includes an equalizer and other circuitry that analyzes the predetermined preamble of the received signal compared to known data and “learns” the parameters associated with the multi-path medium through which the signal was propagated. The single-carrier receiver 207 also examines the header to determine if the packet is intended for the mixed signal receiver 201 and if the packet is a mixed packet, and if so, causes the switch 205 to provide the remaining portion of the incoming signal to a multi-carrier receiver 209. It is noted that the header includes a mixed mode identifier (not shown), such as a mode bit or the like,

that identifies the packet as a mixed mode packet. Thus, in one embodiment, the single-carrier receiver 207 determines that the packet is intended for the mixed signal receiver 201 from a destination address or the like, and determines that the packet is a mixed mode packet from the mode identifier. If the packet is intended for the mixed signal receiver 201 but is not a mixed mode packet (e.g., a standard 802.11b packet), then the single-carrier receiver 207 continues to process the packet. A length field is also provided in the header which includes a length value that identifies the total length of the mixed mode packet. Thus, any device, including mixed mode or legacy devices (e.g. 802.11b devices), may determine that the packet is not intended for it, and backs-off by an amount of time corresponding to the length value.

The multi-carrier receiver 209 is configured to receive the signal, which is transmitted according to OFDM or the like. The multi-carrier receiver 209 is coupled to the single-carrier receiver 207 so that the multi-path information determined by the single-carrier receiver 207 is re-used to enable a smooth transition between the packet portions of the incoming signal. In particular, the AGC (power), carrier frequency, carrier phase, equalizer, and timing parameters from the single-carrier receiver 207 are used by the multi-carrier receiver 209 to receive the incoming signal. The OFDM multi-carrier receiver 209 need not re-acquire the signal, since the information used by the single-carrier receiver 207 is obtained and used.

FIG. 3 is a conceptual diagram of a mixed signal packet 301 implemented according to an embodiment of the present invention. The packet 301 includes a Barker Preamble 303, which is transmitted at 1 megabits per second (Mbps), followed by a Barker Header 305, which is transmitted at 1 or 2 Mbps, followed by one or more OFDM symbols 307 incorporating payload data, which is transmitted at any

selected data rate from among typical data rates of 6, 9, 12, 18, 24, 36, 48 or 54 Mbps with a selected sample rate of 20 megahertz (MHz). The preamble 303 and header 305 are transmitted with a single carrier at the 11 MHz Quadrature Phase Shift Keying (QPSK) symbol rate (and Binary Phase Shift Keying [BPSK] is also contemplated). Different OFDM sample rates are contemplated, such as 18.333 megahertz (MHz), 22 MHz, etc., in which the same principles apply. The transmit signal is specified for complementary code keying OFDM, or CCK-OFDM (802.11b preamble and header using Barkers [single carrier] followed by OFDM [multi-carrier]). The OFDM portion of the waveform can optionally be one of several effective sample rates (e.g., 22, 20, or 18.33 MHz). The packet 301 is shown employing the 802.11a sample rate of 20 MHz. The goal is to specify the signal so that the channel impulse response (CIR) estimate obtained on the preamble and header is reusable on the OFDM. Hence, the transition is completely specified, with no free variables, which allows important equalizer information to be retained at switch-over. Also, it is desirable to eliminate receiver power changes due to the signal transition. A power step may cause legacy equipment to enter an undefined state, since they do not have knowledge of the OFDM, nor the capability to receive it.

FIGs 4A and 4B are graph diagrams of plots of the spectrum of the 802.11b Barker chips and the 802.11a OFDM, respectively, in decibels (dB) versus normalized frequency (freq). Spectrum refers to center frequency, power spectral density, and frequency response. The 802.11b Barker chip spectrum has a round "top" whereas the 802.11a OFDM spectrum has a flat top. The 3 dB bandwidths are also different. FIGs 5A and 5B are graph diagrams of time domain plots of the 802.11b QPSK Barker chips and the 802.11a OFDM, respectively, illustrating that the waveforms are radically different. It is desired to create a smooth transition between the

preamble/header single-carrier portion 303, 305 and the OFDM symbol portion 307 even though the waveforms are different. One solution is to make the 802.11b Barker preamble and header look like OFDM with approximately the same transmit spectrum and approximately the same power.

5           FIGs 6A is a graph diagram of a plot of the power spectral density (PSD) of a single sub-carrier out of the possible 64 possible sub-carriers defined in the 802.11a standard, in dB versus frequency. FIG. 6B is a graph diagram of a plot of the composite PSD of the 52 non-zero sub-carriers used in 802.11a. The curves are plotted versus normalized frequency (nfreq) and frequency in MHz, respectively. It is  
10   desired to design a spectrum/time shaping pulse, which makes the spectrum of the single-carrier portion of the signal resemble OFDM. This pulse is made known so that the receiver is able to compensate the CIR for the OFDM portion of the packet. The pulse is specified in continuous time, so that it is implementation independent. For digital implementations, the pulse may be sampled at any desired appropriate  
15   implementation rate. The signal should provide a nearly flat spectrum in the pass-band with sufficiently steep roll-off on the band edges. It is desired that the transmit pulse be easily handled by 802.11b legacy receivers. It should have a dominant peak, therefore, with a small amount of spread in the impulse response. This allows the 802.11b receiver to lock on to this impulse response component. It is desired that the  
20   signal have a short duration to minimize complexity.

FIG. 7A is a graph diagram of a plot of an exemplary “brickwall” double-sided spectrum centered at 0 MHz, having a magnitude of 1 at a selected bandwidth of approximately  $2(8.5) = 17$  MHz and 0 otherwise. A brickwall spectrum is essentially an idealized low-pass filter. The exemplary frequency range is selected as



(2)(27)(20MHz/64) = 16.875 MHz in the embodiment shown. FIG. 7B is a graph diagram of a portion of the associated infinite-duration time response corresponding to the brickwall spectrum. In general, a target spectrum is chosen for the single carrier system. This is done by specifying a brickwall approximation to the desired spectrum. A brickwall spectrum has an infinite impulse response in the time domain (i.e., spans from +/- infinity). The pulse is then truncated using a continuous-time window. A long enough window is chosen to give the desired spectral characteristics while a short enough window is chosen to minimize complexity, each generally employing engineering judgment.

FIG. 8 is a graph diagram of a plot of an exemplary continuous-time window, which is a continuous time version of a Hanning window. It is appreciated that this is only one of many different window configurations that may be successfully employed to achieve desirable results. FIG. 9 is a graph diagram of a plot of the Hanning window overlaid with the portion of the infinite-duration time response corresponding to the brickwall spectrum. FIG. 10 is a graph diagram of a plot of the resulting exemplary pulse  $p(t)$  truncated to approximately 0.8  $\mu\text{s}$  so that it is zero outside +/- 0.4  $\mu\text{s}$ . The short duration of the pulse  $p(t)$  provides low complexity. FIG. 11 is a graph diagram of a plot of the spectral characteristics of the pulse  $p(t)$  illustrating that it is a close match to the OFDM spectrum. The spectral characteristics of the pulse  $p(t)$  include a nearly flat spectrum where OFDM is flat and a fast roll-off where OFDM rolls off. The continuous time pulse can be used to construct any digital filter unambiguously and is independent of particular implementations. The Nyquist criteria (sampling of the continuous time pulse) should be satisfied at the level of the target fidelity. The pulse  $p(t)$  is "digitized" or sampled

according to the Nyquist criterion. In some embodiments, the samples are then decomposed as described further below.

FIG. 12 is a block diagram of an exemplary digital filter 1201 employed to architect a digital 22 MHz output sample rate using the continuous time pulse  $p(t)$ . In this case, an exemplary QPSK symbol generator 1203 provides an 11 MHz signal to respective inputs of each of a pair of polyphase digital filters 1205 and 1207. The QPSK symbol generator 1203, used as an exemplary transmitter for illustration, passes each symbol (a complex number) to both of the digital filters 1205 and 1207 at a rate of 11 MHz each. Each digital filter 1205 and 1207 samples the input waveform and generates an output at 11 MHz. The digital filter taps 1205 are composed of even numbered samples and the digital filter taps 1207 are composed of odd numbered samples of the pulse  $p(t)$ . Select logic 1209, such as multiplexor (MUX) circuitry or the like, selects every output of the polyphase digital filter taps 1205 and 1207 to achieve a  $2(11) = 22$  MHz sample rate signal. FIG. 13 is a graph diagram illustrating the sampling and polyphase decomposition of the continuous time pulse  $p(t)$  (plotted versus time in microseconds, " $\mu\text{s}$ "). Since every output of every filter is used, the effective sampling rate is 22 MHz.

FIG. 14 is a block diagram of another exemplary digital filter 1401 employed to architect a digital 20 MHz output sample rate using the pulse  $p(t)$ . In this case, an exemplary QPSK symbol generator 1403, similar to the generator 1203, provides an 11 MHz signal to respective inputs of twenty polyphase digital filters 1405, 1407, 1409, ..., 1411. Each digital filter 1405-1411 generates an output at 11 MHz, so that the sampling rate is increased from 11 MHz to 220 MHz. Each filter consists of the samples spaced 20 samples apart. Select logic 1413, such as multiplexor (MUX)

circuitry or the like, selects one of every 11 outputs of the polyphase digital filters 1405-1411 to achieve a 20 MHz sample signal. For example, for the first QPSK symbol, the respective outputs of filters 1 and 11 are used and for the second QPSK symbol, the respective outputs of filters 19 and 10 are used, etc. Also, one out of every eleven input symbols will generate 1 output sample, whereas the remaining input samples each generate two output samples. FIG. 15 is a graph diagram illustrating the sampling and polyphase decomposition of the continuous time pulse  $p(t)$  plotted versus time. Since one out of every 11 outputs is used of the 220 MHz combined output of the filters 1405-1411, the effective sampling rate is 20 MHz.

FIG. 16 is a block diagram of a transmitter 1601 implemented according to an embodiment of the present invention. The transmitter 1601 includes an OFDM Kernel block 1603 supplying the OFDM portion of the signal to a soft switch block 1607, which receives the 802.11b preamble and header portion from an 802.11b preamble/header Kernel block 1605. The soft switch block 1607 provides the 802.11g signal to a digital to analog converter (DAC) 1609, which provides a resulting analog signal to a low-pass filter (LPF) 1611. The filtered signal is provided to a SAW filter 1613, illustrating that linear distortions are induced on both signal segments. The output of the SAW filter 1613 is provided to one input of a mixer 1615, having another input which receives a local oscillator (LO) signal from a local oscillator 1617. The mixer 1615 asserts a mixed or combined signal at its output.

Distortions can be induced in the transmitter, multi-path channel and receiver. An obvious linear distortion in the transmitter is a SAW filter, such as the SAW filter 1613. In communications systems, it is frequently assumed that linear distortions are common and (essentially) time-invariant across waveform symbols. For example,

linear distortions are assumed common between the preamble/header and payload portions for both 802.11a and 802.11b communications. In a similar manner, linear distortions of the transmit radio are assumed to be common to both the single-carrier segment and the multi-carrier segment. In this manner, a spectral binding requirement is imposed to allow the equalizer information and the AGC to carry over from single-  
5 to multi-carrier.

The transmitter 1601 further illustrates a sample-power matching scheme to enable the AGC information to carry over from single-carrier to multi-carrier portions of the signal. In particular, it is desired that the average signal power output from the  
10 OFDM Kernel block 1603, as shown at 1620, be approximately the same as the average signal power output from the 802.11b preamble/header Kernel block 1605, as shown at 1622.

FIG. 17 is a graph diagram comparing the 11 MHz Barker chip clock shown at 1701 versus the 20 MHz OFDM sample clock shown at 1703, both plotted versus  
15 time in  $\mu\text{s}$ . The 802.11b communication scheme uses a chip rate of 11 MHz. The 802.11b preamble/header uses 11 chip Barker words, so that there are 11 chips/ $\mu\text{s}$ . The 802.11a OFDM uses a 20 MHz sample rate. In the embodiment shown, in order to achieve transition time alignment, the 802.11b (11 MHz) and 802.11a (20 MHz) signal segments are aligned at the 1 MHz boundary, every 1  $\mu\text{s}$  interval, illustrated by  
20 alignment epochs 1705 at each 1  $\mu\text{s}$  interval. FIG. 18 is a conceptual graph diagram illustrating alignment of the OFDM signal portion with the last Barker word of the header of the single-carrier portion. The first chip of each Barker word, shown at 1803, is centered on the 1  $\mu\text{s}$  alignment. The first full 20 MHz sample of the OFDM signal, shown at 1801, occurs 1  $\mu\text{s}$  after the zero-phase peak of first chip of the last

Barker word in the header. Effectively, one half-scale OFDM sample, shown at 1805, occurs before the full scale sample (for smoothing). Such transition time alignment allows the equalizer information and the timing information to carry over between the single- and multi-phase portions of the signal.

5           FIG. 19 is a graph diagram illustrating normal OFDM symbol overlap. FIG. 20 is a graph diagram illustrating exemplary 802.11a OFDM symbol onset and termination. FIG. 21 is a graph diagram illustrating exemplary single-carrier termination, shaped consistent with 802.11a as shown at 2101, and OFDM onset shaped identical to 802.11a, as shown at 2103. As illustrated in these graph diagrams, 10 the single-carrier is terminated in a controlled fashion when transitioning from single-carrier to multi-carrier. This single-carrier termination maintains the AGC at the point of transition, minimizes the signal power gap, which in turn minimizes the corruption of one signal by the other. The single-carrier termination of the 802.11b segment is similar to that used for 802.11a OFDM shaping. 802.11a specifies a 15 windowing function for OFDM symbols, which is employed to define termination of single-carrier segment. The single-carrier signal is terminated in a predetermined window of time, such as nominally 100 nanoseconds (ns). It is not necessary to completely flush the single-carrier pulse-shaping filter. The resulting distortion to the last Barker word in the header is trivial compared to the 11 chips processing gain, 20 thermal noise and multi-path distortion. The termination may be accomplished either explicitly in the digital signal processing or by analog filtering.

It is further desired that the carrier frequency be coherent for both waveform segments, achieved by using a single LO signal via the local oscillator 1617. This

allows the equalizer information to carry over. Carrier frequency lock may be maintained with a phase-lock loop (PLL) circuit or the like.

It is further desired that the carrier phase be aligned, which allows the equalizer information to carry over. FIG. 22A is a simplified graph diagram of a BPSK plot illustrating that BPSK incorporates both real and imaginary portions in two quadrants (1 of 2 phases). FIG. 22B is a simplified graph diagram of a QPSK plot illustrating that QPSK incorporates both real and imaginary portions in all four quadrants (1 of 4 phases). The single-carrier signals, employing Direct Sequence Spread Spectrum (DSSS), are fundamentally different as compared to the OFDM signal format and modulation schemes. For 802.11g CCK-OFDM, either of these formats are re-used for the header.

FIG. 23 is a series of graph diagrams illustrating the phase relationship between the last Barker word, rather than the last chip, in the 802.11g header and subsequent OFDM symbol samples. Annex G of the 802.11a standard describes how to transmit an OFDM symbol including real and imaginary components. The arrows shown at 2301, 2303, 2305 and 2307 illustrate the four possible phases of the last Barker word. The phase of the OFDM symbol is determined by the phase of the last Barker word, in that each OFDM sample is either not rotated or rotated by the same, predetermined amount based on the phase of the last Barker word. The arrows shown at 2302, 2304, 2306 and 2308 represent the corresponding four relative phase shifts applied to the OFDM symbol corresponding to the Barker phase illustrated by arrows 2301, 2303, 2305 and 2307, respectively. For example, if the phase of the last Barker word is in the first quadrant, then the phase of the OFDM symbols will be rotated by zero degrees (not rotated, or multiplied by 1) relative to the OFDM phase as described

in Annex G of the 802.11a standard. Furthermore, if the phase of the last Barker word is in the second quadrant (135 degree phase rotation), then the phase of the OFDM symbols will be rotated by 90 degrees relative to the phase of the samples in 802.11a Annex G (i.e., multiplied by “j”); if the phase of the last Barker word is in the third quadrant (-135 degree phase rotation), then the phase of the OFDM symbols will be rotated by 180 degrees relative to the phase of the samples in 802.11a Annex G (i.e., multiplied by “-1”); and if the phase of the last Barker word is in the fourth quadrant (-45 degree phase rotation), then the phase of the OFDM symbols will be rotated by -90 degrees relative to the phase of the samples in 802.11a Annex G (i.e., multiplied by “-j”).

In many design implementations, it is often desired to know the relative accuracy and fidelity requirements to maintain signal integrity and compatibility among different transceivers. In this manner, designers are able to reduce costs and maximize efficiency while maintaining parameters and characteristics within specification. The accuracy characteristic constrains the short-cuts the transmit designer may make which may otherwise significantly harm receiver performance. In one embodiment, the requisite fidelity of the entire waveform behavior is established using a metric based on the fidelity requirements of the OFDM signal of the 802.11a standard. Thus, the requisite fidelity of the single-carrier portion is the same as the multi-carrier portion even though the single-carrier portion is typically at a reduced data rate. As described in the 802.11a specification, the requisite fidelity for OFDM is set by the error vector magnitude (EVM) specification, as illustrated in the following Data Rate versus EVM Table 1:

Table 1: Data Rate versus EVM specification

Data Rate Mbps	EVM Spec
6	-5
9	-8
12	-10
18	-13
24	-16
36	-19
48	-22
54	-25

where data rate is specified in Mbps and EVM is specified in dB. As illustrated in Table 1, the OFDM accuracy is a function of the data rate. The higher the data rate, the more complex and intricate the transmit waveform, and the greater the accuracy necessary. This requisite fidelity is applied to the entire waveform. EVM is the same thing as mean-squared-error (MSE) normalized by the signal power. MSE may be measured after best-fit time alignment, best-fit gain alignment, and best-fit phase alignment. Also, linear distortion common to OFDM and the single-carrier Barker chips may be backed-out, if desired. If and when the 802.11b accuracy specification becomes more stringent, it may be used for the single-carrier portion.

Portions of 802.11b specification and all of the 802.11a specification employ a locked-oscillator requirement. A locked oscillator characteristic allows timing tracking information to be derived from carrier frequency and phase. There are two fundamental clocks in a transmit waveform: a symbol rate clock and a carrier frequency. In at least one embodiment of the transmitter, all of the 802.11g signals have a symbol rate clock and carrier frequency derived from the same clock reference. It is further desired that the part-per-million (PPM) error on these two clock signals be equal. The receiver is allowed to track symbol rate timing from carrier frequency error.



The multi-carrier receiver 209 portion of the mixed signal receiver 201 obtains the behavior of the transition from the single-carrier receiver 207 of the waveform as described herein to receive the OFDM portion of the signal. The carrier frequency and phase is coherent. Furthermore, the time alignment, the signal level (AGC), and the channel impulse response (CIR) are each coherent. The single-carrier receiver 207 determines the CIR estimate during the single-carrier portion. The multi-carrier receiver 209 modifies the CIR estimate for the OFDM using the known pulse shape used by the single-carrier segment. In particular, the equalizer taps of the multi-carrier receiver 209 are modified using the known pulse shape used by the transmitter during the single-carrier preamble and header. In this manner, the multi-carrier receiver 209 does not have to reacquire the OFDM portion of the signal, but uses the information obtained by the single-carrier receiver 207 along with predetermined or known information for a smooth single-carrier to multi-carrier signal transition. Also, a separate OFDM preamble/header is not necessary, although it may be employed for both convenience and fine tuning, if desired.

Although a system and method according to the present invention has been described in connection with the preferred embodiment, it is not intended to be limited to the specific form set forth herein, but on the contrary, it is intended to cover such alternatives, modifications, and equivalents, as can be reasonably included within the spirit and scope of the invention.

## Claims:

1           1.       A wireless communication system that is configured to communicate  
2 using a mixed waveform configuration, comprising:

3           a transmitter configured to transmit according to a mixed waveform  
4 configuration including a first portion modulated according to a single-carrier scheme  
5 with a preamble and header and a second portion modulated according to a multi-  
6 carrier scheme;

7           the waveform being specified so that a channel impulse response estimate  
8 obtainable from the first portion is reusable for acquisition of the second portion; and

9

10          a receiver configured to acquire and receive packets with a mixed waveform  
11 configuration.

1           2.       The wireless communication system of claim 1, wherein the  
2 transmitter maintains power, carrier phase, carrier frequency, timing, and multi-path  
3 spectrum between the first and second portions of the waveform.

1           3.       The wireless communication system of claim 2, wherein the  
2 transmitter comprises:

3           a first kernel that modulates the first portion according to the single-carrier  
4 modulation scheme;

5           a second kernel that generates the second portion according to the multi-  
6 carrier modulation scheme; and

7           a switch, coupled to the first and second kernels, that selects the first kernel for  
8 the first portion and the second kernel for the second portion to develop a transmit  
9 waveform.

1           4.     The wireless communication system of claim 3, wherein the first  
2 kernel operates at a first sample rate and wherein the second kernel operates at a  
3 second sample rate.

1           5.     The wireless communication system of claim 3, wherein the first  
2 kernel employs a single-carrier spectrum that resembles a multi-carrier spectrum of  
3 the multi-carrier modulation scheme.

1           6.     The wireless communication system of claim 5, wherein the first  
2 kernel employs a time shaping pulse that is specified in continuous time.

1           7.     The wireless communication system of claim 6, wherein the time  
2 shaping pulse is derived employing an infinite impulse response of a brick wall  
3 approximation that is truncated using a continuous-time window that is sufficiently  
4 long to achieve desired spectral characteristics and sufficiently short to minimize  
5 complexity.

1           8.     The wireless communication system of claim 6, wherein the first  
2 kernel samples the time shaping pulse according to a Nyquist criterion.

1           9.     The wireless communication system of claim 3, wherein the average  
2 output signal power of the first kernel and the average output signal power of the  
3 second kernel are maintained substantially equal.

1           10.    The wireless communication system of claim 3, wherein the single-  
2 carrier modulation scheme is according to 802.11b Barkers and wherein the multi-  
3 carrier modulation scheme is according to the 802.11a standard employing orthogonal  
4 frequency division multiplexing (OFDM).

1           11.    The wireless communication system of claim 3, wherein the first  
2 kernel employs a first sample rate clock, wherein the second kernel employs a second  
3 sample rate clock, wherein the first and second sample rate clocks are aligned at  
4 predetermined timing intervals, and wherein a first full sample of the multi-carrier  
5 modulation scheme begins one timing interval after the beginning of a last sample of  
6 the single-carrier modulation scheme.

1           12.    The wireless communication system of claim 3, wherein the single-  
2 carrier signal from the first kernel is terminated according to a windowing function  
3 specified for OFDM signal shaping defined in the 802.11a standard.

1           13.    The wireless communication system of claim 3, wherein carrier  
2 frequency is coherent between the first and second kernels.

1           14.    The wireless communication system of claim 3, wherein carrier phase  
2 is coherent between the first and second kernels.

1           15.    The wireless communication system of claim 14, wherein carrier phase  
2 of the second kernel multi-carrier signal is determined by carrier phase of a last  
3 portion of the second kernel single-carrier signal.

1           16.    The wireless communication system of claim 15, wherein carrier phase  
2 of the second kernel multi-carrier signal is rotated by a corresponding one of a  
3 plurality of rotation multiples, each rotation multiple corresponding to one of a  
4 plurality of predetermined phases of the last portion of the second kernel single-  
5 carrier signal.

1           17.    The wireless communication system of claim 16, wherein the first  
2 kernel single-carrier modulation scheme is according to 802.11b Barkers in which  
3 each Barker word is one of first, second, third and fourth possible phases, wherein the  
4 second kernel multi-carrier modulation scheme is according to OFDM as defined in  
5 Annex G of the 802.11a standard, and wherein OFDM symbol are rotated by the  
6 second kernel by zero if the last Barker word has the first phase, by 90 degrees if the  
7 last Barker word has the second phase, by 180 degrees if the last Barker word has the  
8 third phase, and by -90 degrees if the last Barker word has the fourth phase.

1           18.    The wireless communication system of claim 3, wherein a requisite  
2 fidelity of the entire mixed waveform configuration is specified by a requisite fidelity  
3 specified for the multi-carrier scheme.

1           19.    The wireless communication system of claim 18, wherein the requisite  
2 fidelity is a function of data rate of the second portion and is determined by mean-  
3 squared-error normalized by signal power as specified for OFDM in the 802.11a  
4 standard.

1           20.    The wireless communication system of claim 2, wherein a symbol rate  
2 clock and a carrier frequency of the waveform are derived from the same reference  
3 clock.

1           21.    The wireless communication system of claim 20, wherein part per  
2 million (PPM) error of a clock fundamental for symbol rate and PPM error of a clock  
3 fundamental for carrier frequency are substantially equal.

1           22.    The wireless communication system of claim 2, wherein the receiver  
2 comprises:

3 a single-carrier receiver;  
4 a multi-carrier receiver, coupled to the single-carrier receiver; and  
5 a switch, coupled to the single-carrier receiver and the multi-carrier receiver,  
6 that provides a first portion of a signal being received to the single-carrier receiver  
7 and that provides a second portion of the signal being received to the multi-carrier  
8 receiver;

9 wherein the single-carrier receiver acquires a first portion of an incoming  
10 signal including the preamble and header and determines a channel impulse response  
11 (CIR) estimate, and wherein the multi-carrier receiver uses the CIR estimate for a  
12 second portion of the incoming signal.

1 23. The wireless communication system of claim 22, further comprising:  
2 the single-carrier receiver including a first equalizer, wherein the single-carrier  
3 receiver programs taps of the first equalizer based on the CIR estimate; and  
4 the multi-carrier receiver including a second equalizer, and wherein the multi-  
5 carrier receiver modifies taps of the second equalizer based on the CIR estimate  
6 determined by the first equalizer.

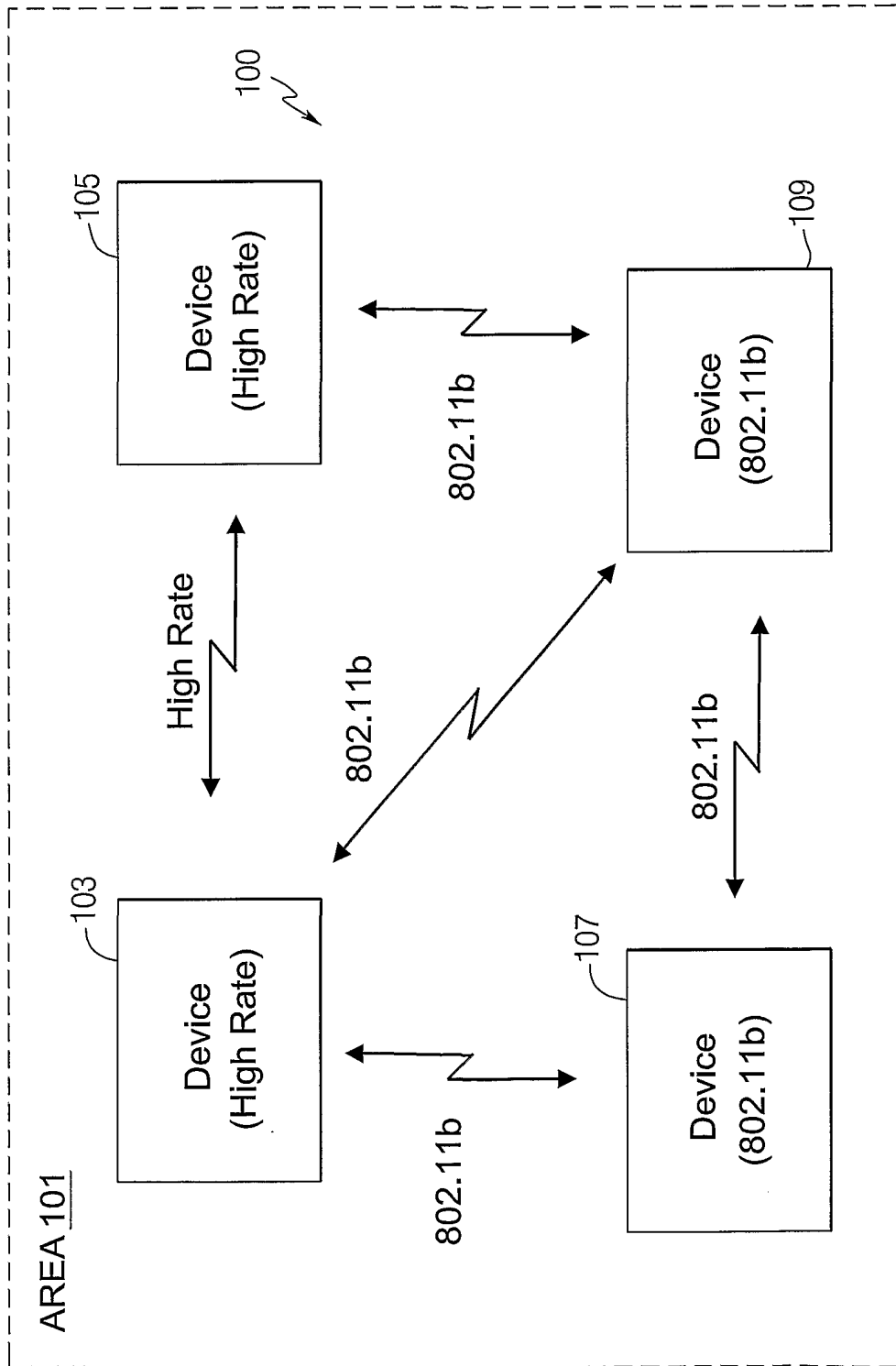

FIG. 1

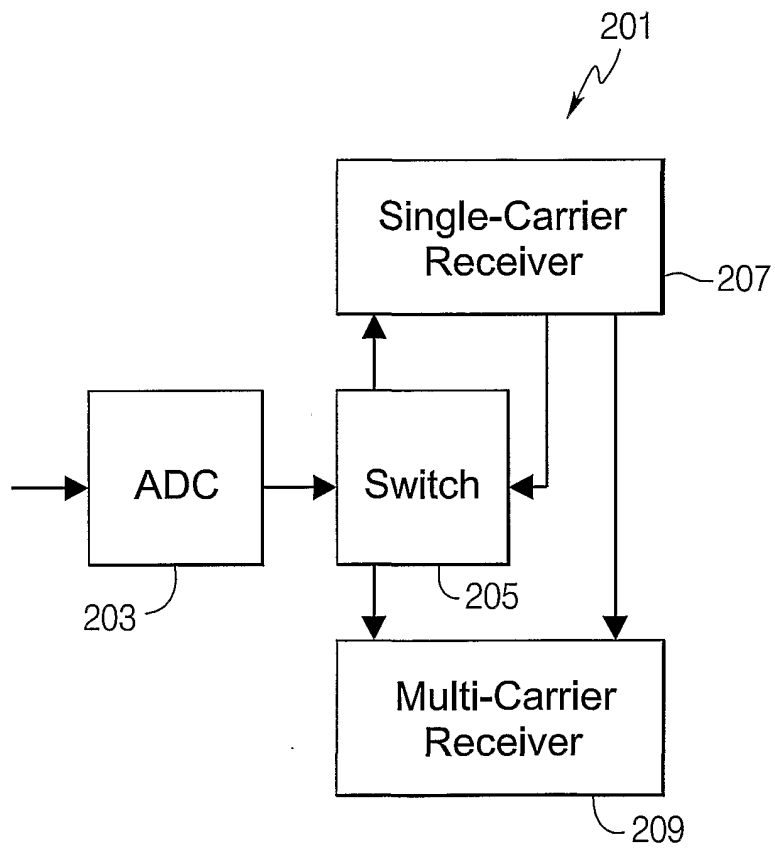

FIG. 2



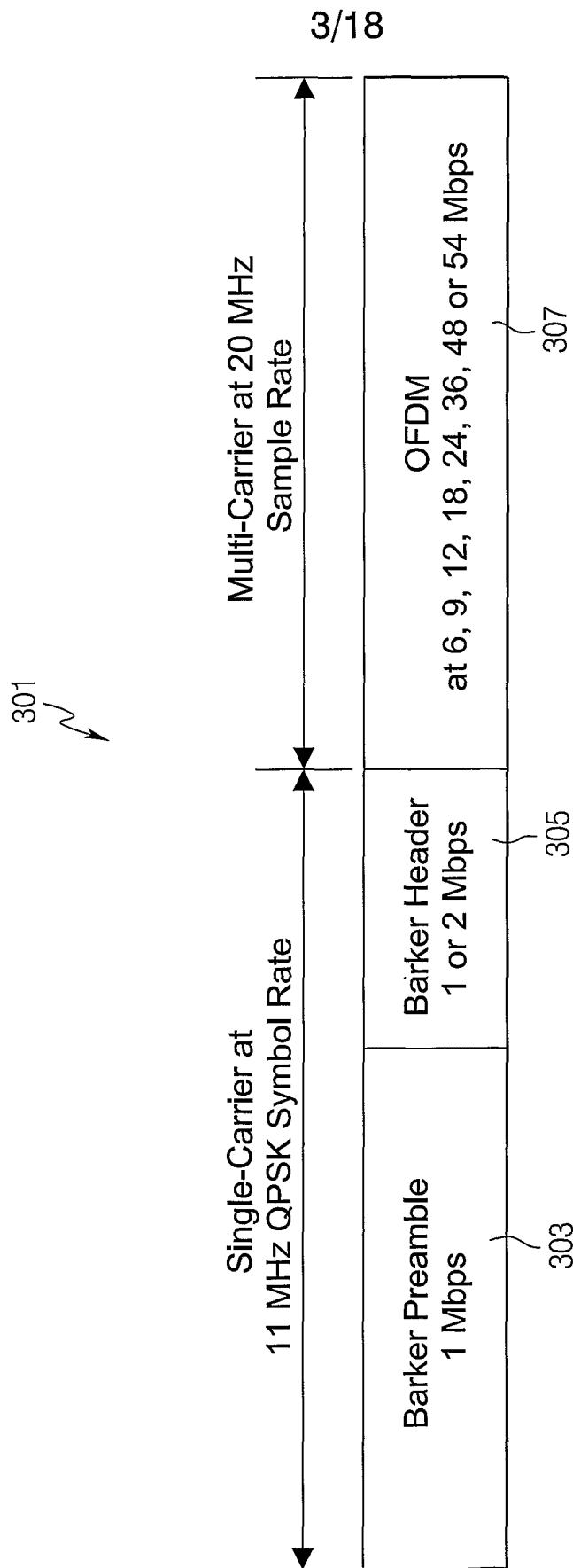
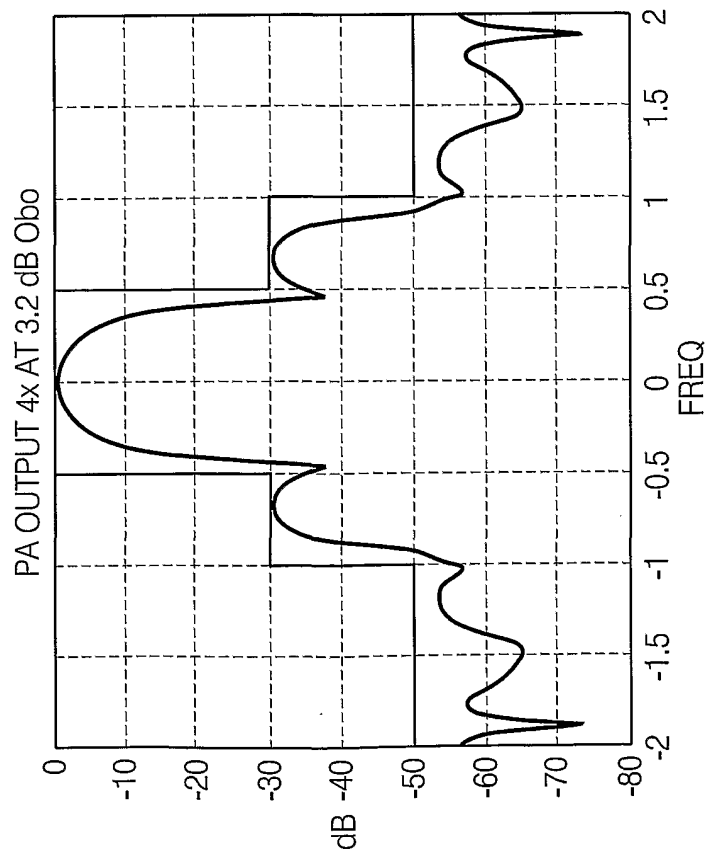

FIG. 3

X

**802.11b Barker**



**FIG. 4A**

**802.11a OFDM**

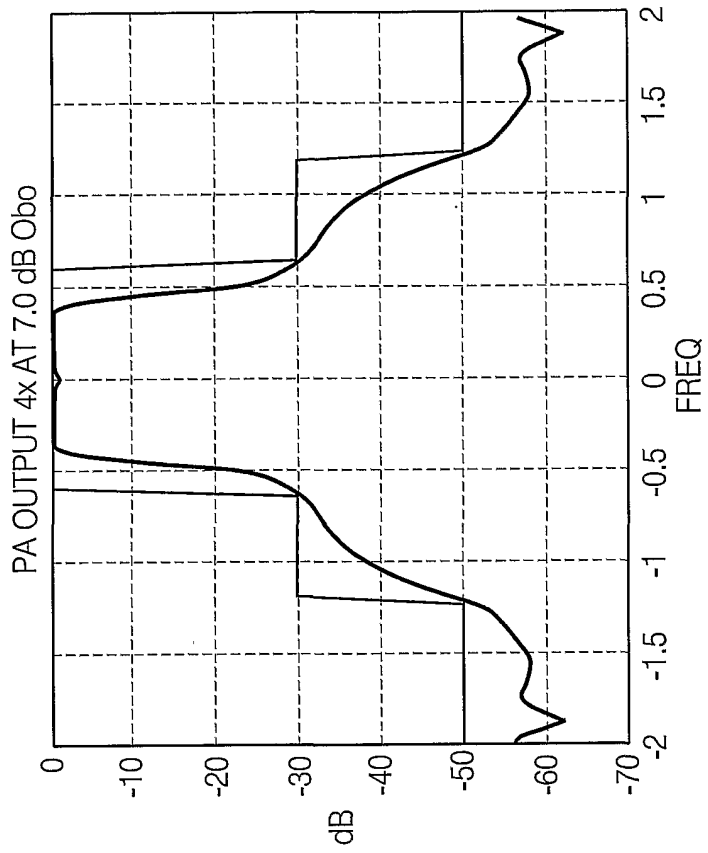

4/18

**FIG. 4B**

802.11a OFDM

Tx Packet 1x

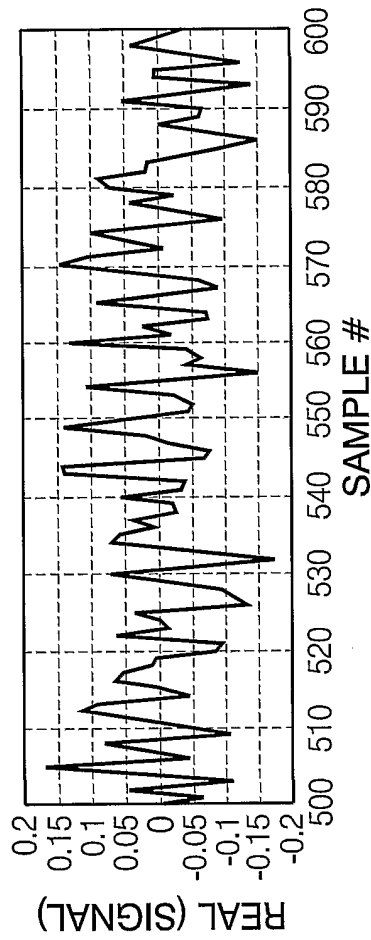

Tx Packet 1x

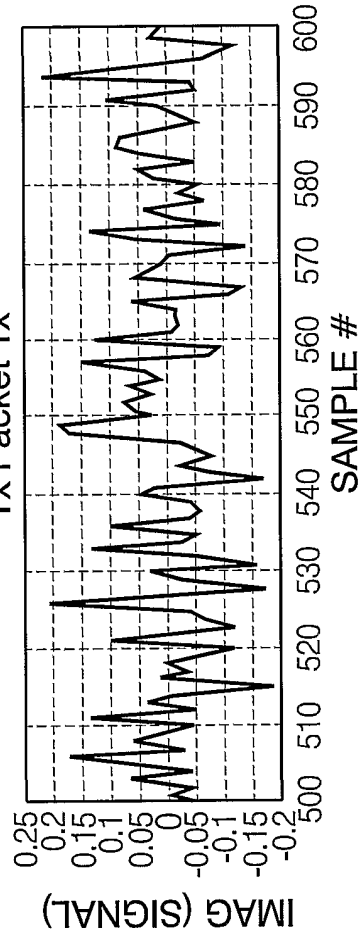

802.11b Barker

EYE PLOT

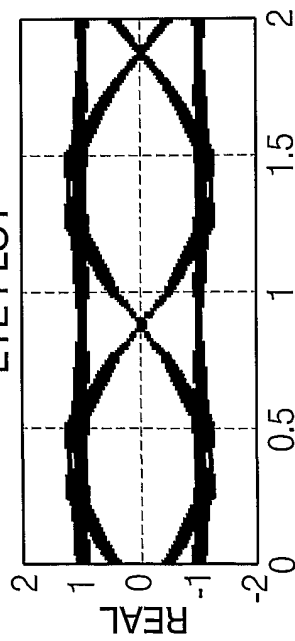

SYMBOLS TIMES

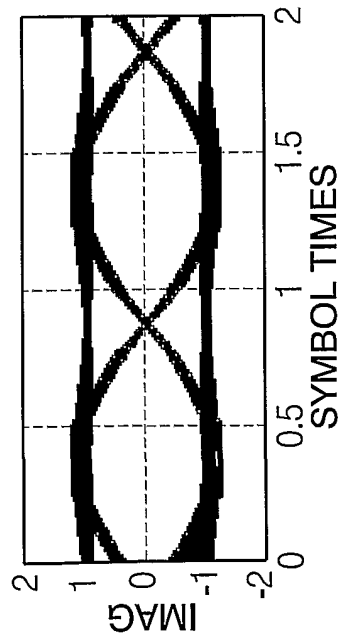
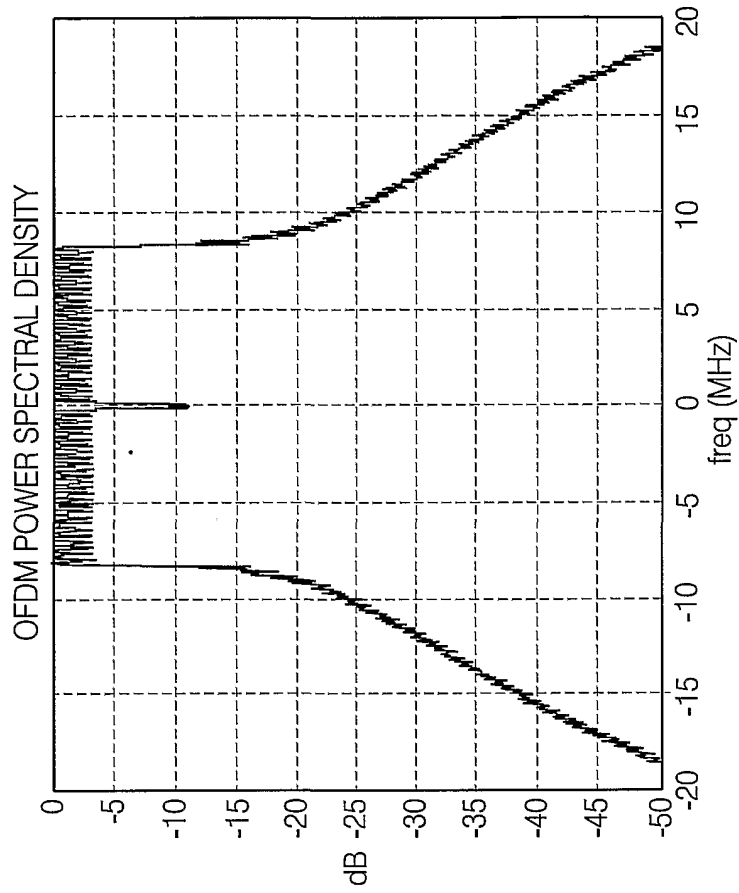

FIG. 5B

FIG. 5A

52 Sub-carrier PSD



Single Sub-carrier PSD

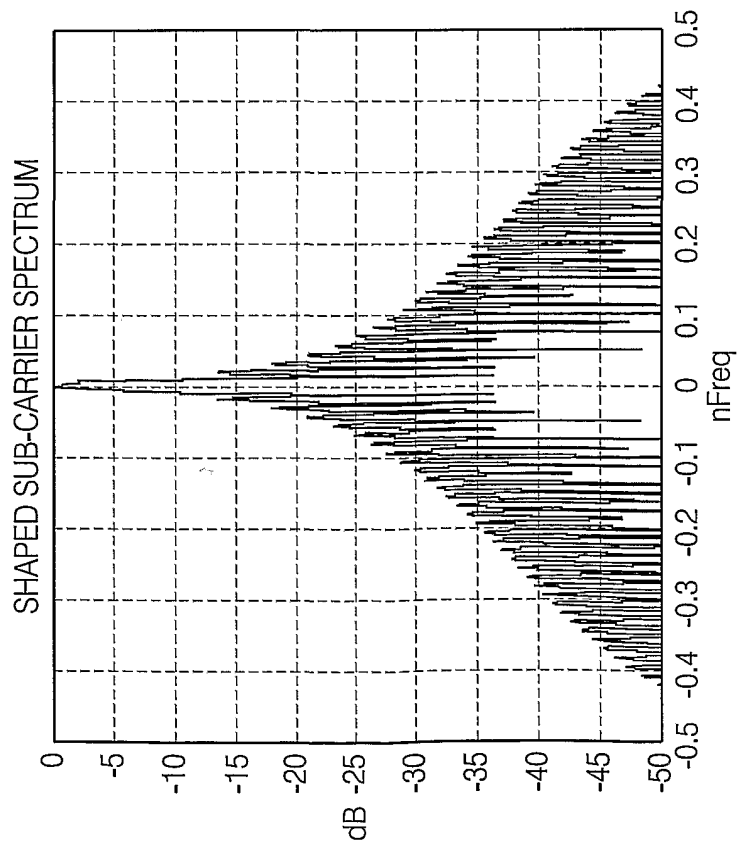
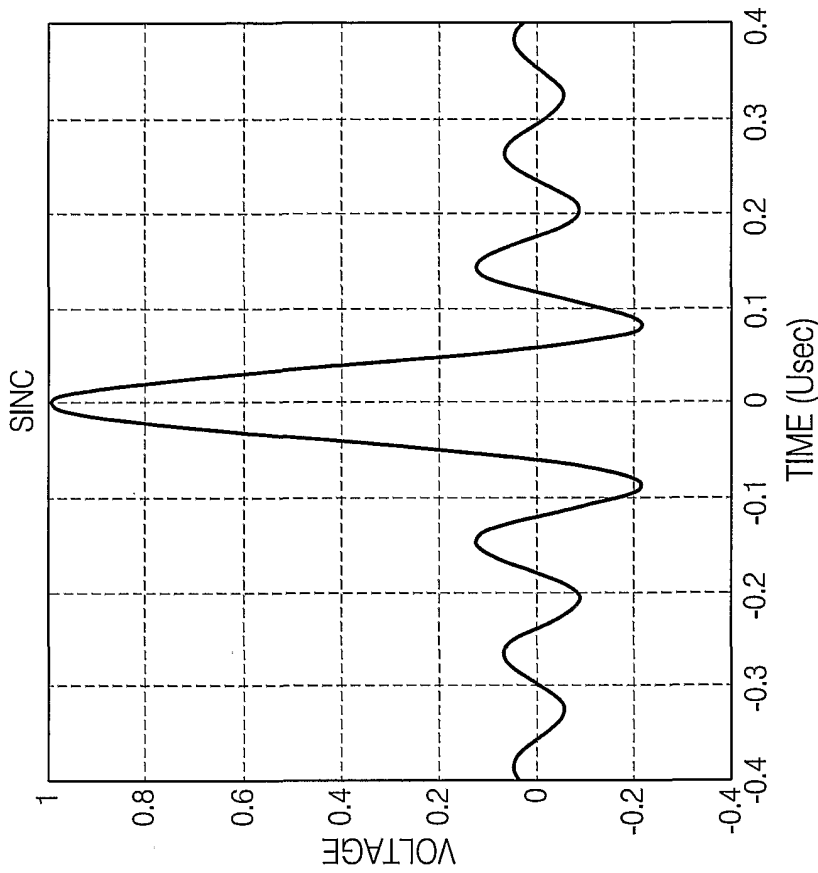

FIG. 6B

FIG. 6A

Associated Infinite-Duration Time Response



$$h_{IdealIBW}(t) = f_W \frac{\sin(\pi f_W t)}{\pi f_W t} = f_W \text{sinc}(f_W t),$$

where  $f_W = 52(20/64)\text{MHz}$

FIG. 7B

Brickwall Spectrum

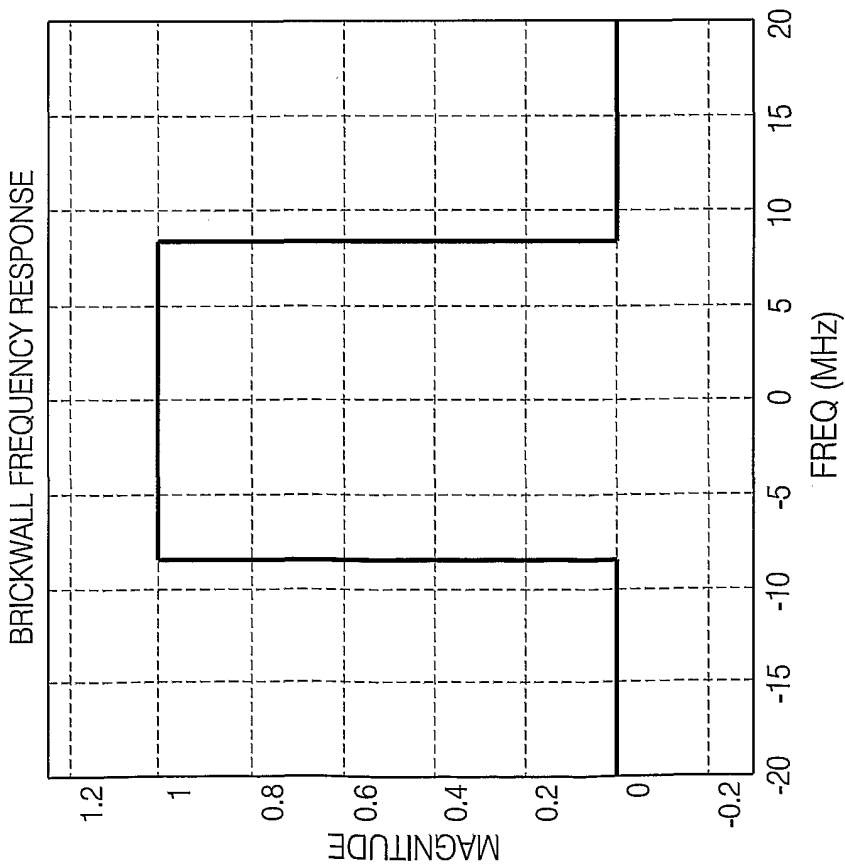
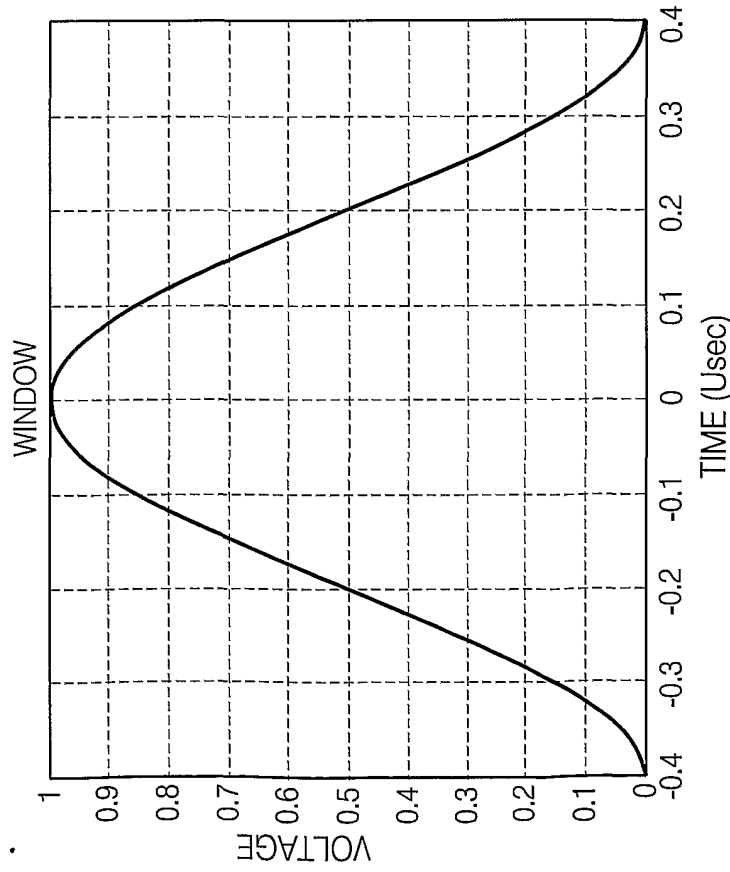

FIG. 7A

Continuous Time Version of Hanning Window



$$h_{Window}(t) = 0.5 \left[ 1 + \cos \left( 2\pi \frac{t}{T_{SPAN}} \right) \right],$$

where  $T_{SPAN} = 0.8 \text{ usecs}$

FIG. 8

Overlay Both

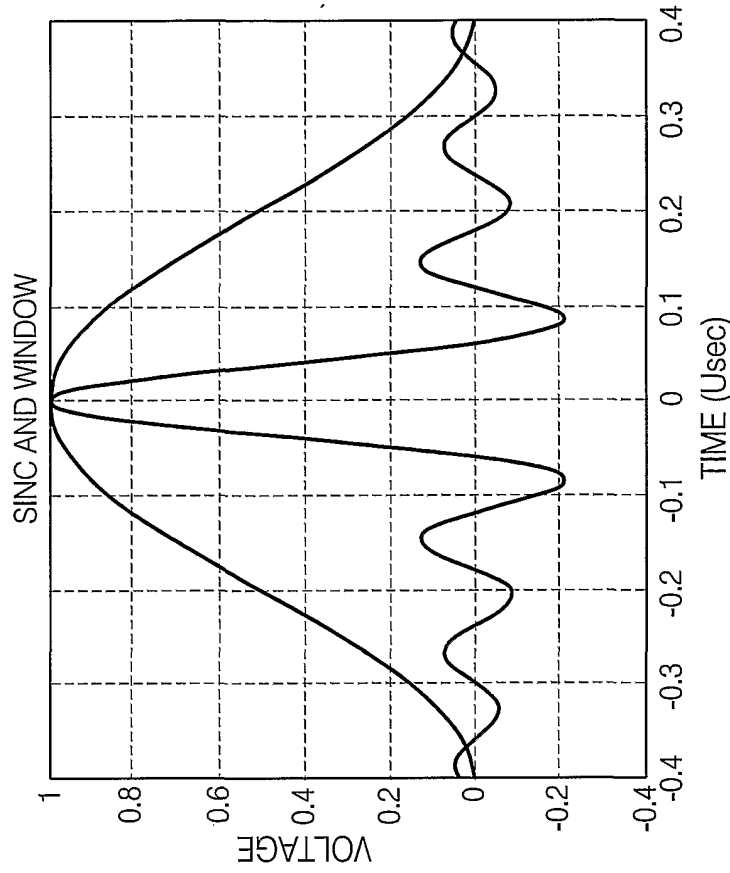

FIG. 9

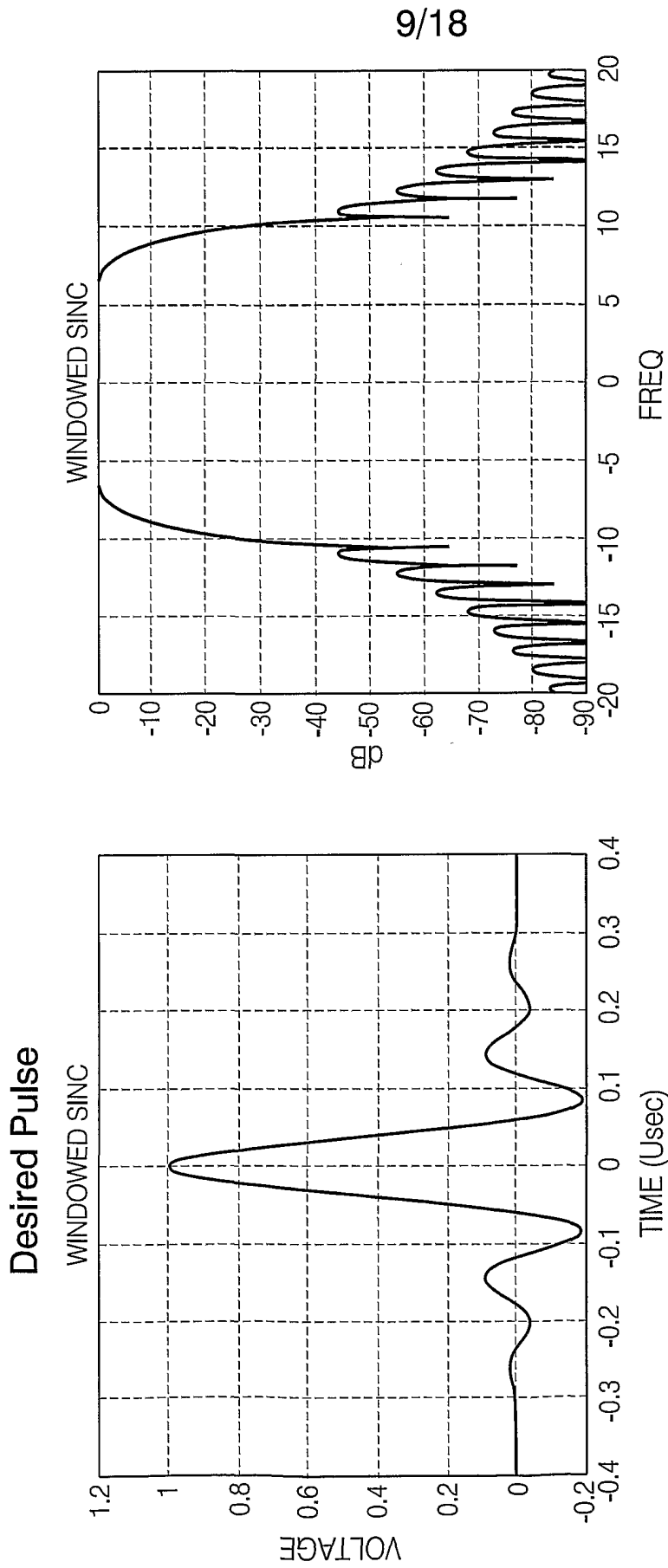

FIG. 11

Same duration as 802.11a Short Sync.

$$p(t) = h_{Window}(t) h_{IdealBW}(t)$$

FIG. 10

10/18

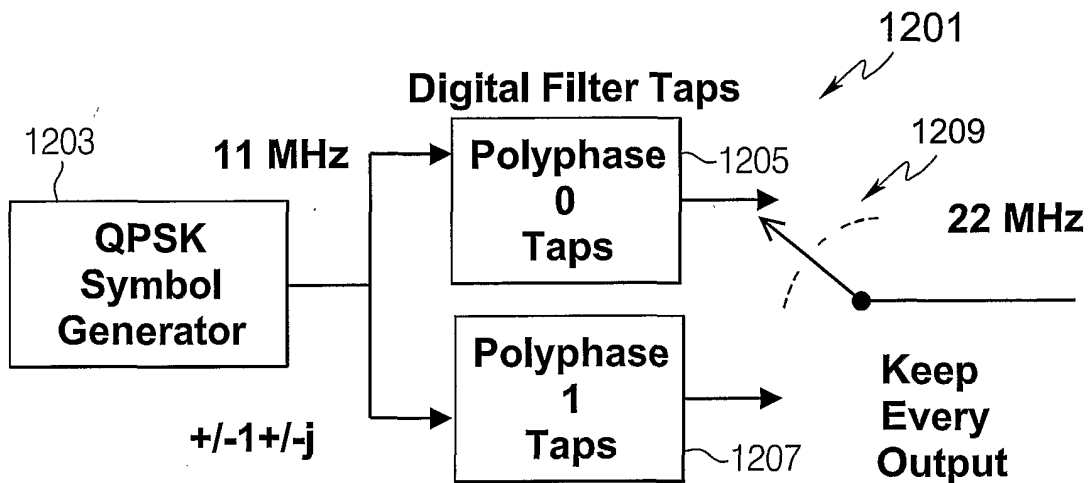

FIG. 12

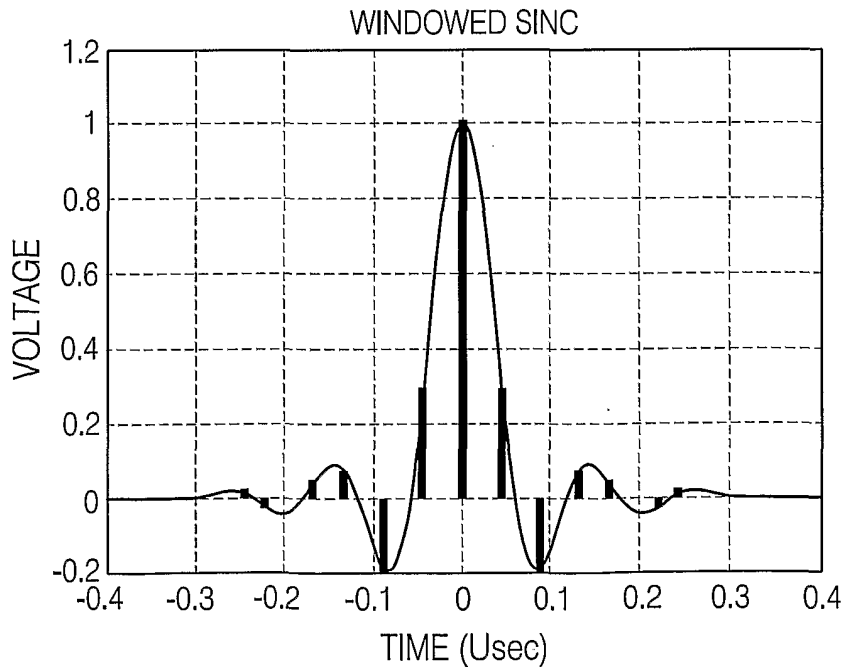

FIG. 13



11/18

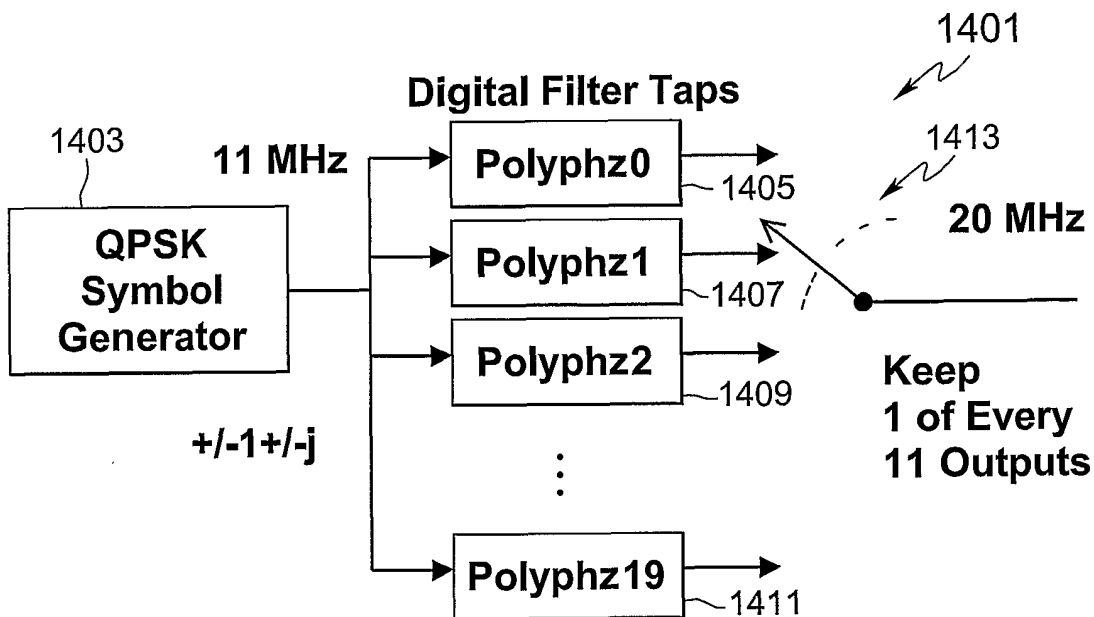

FIG. 14

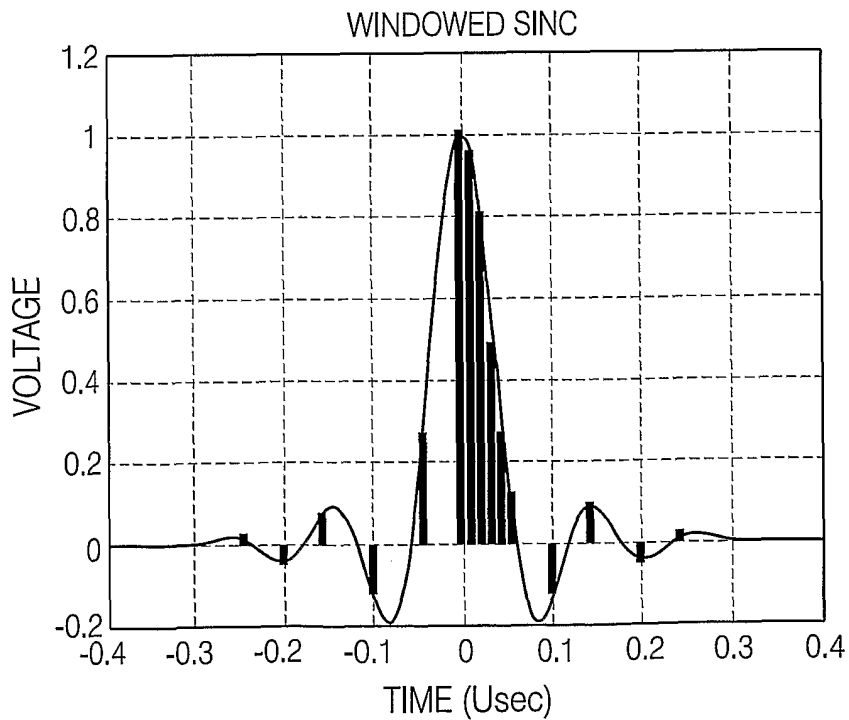

FIG. 15

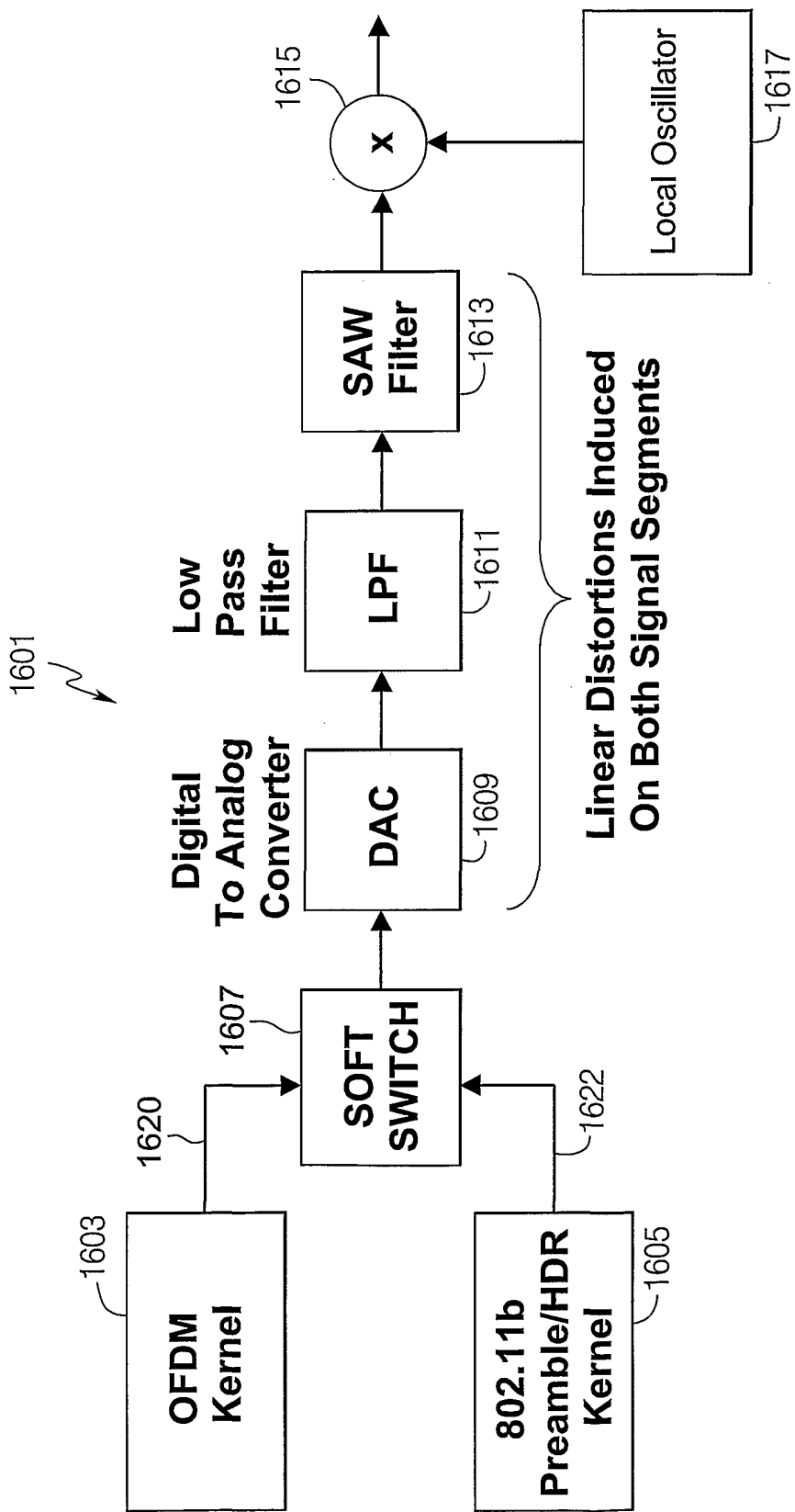

FIG. 16

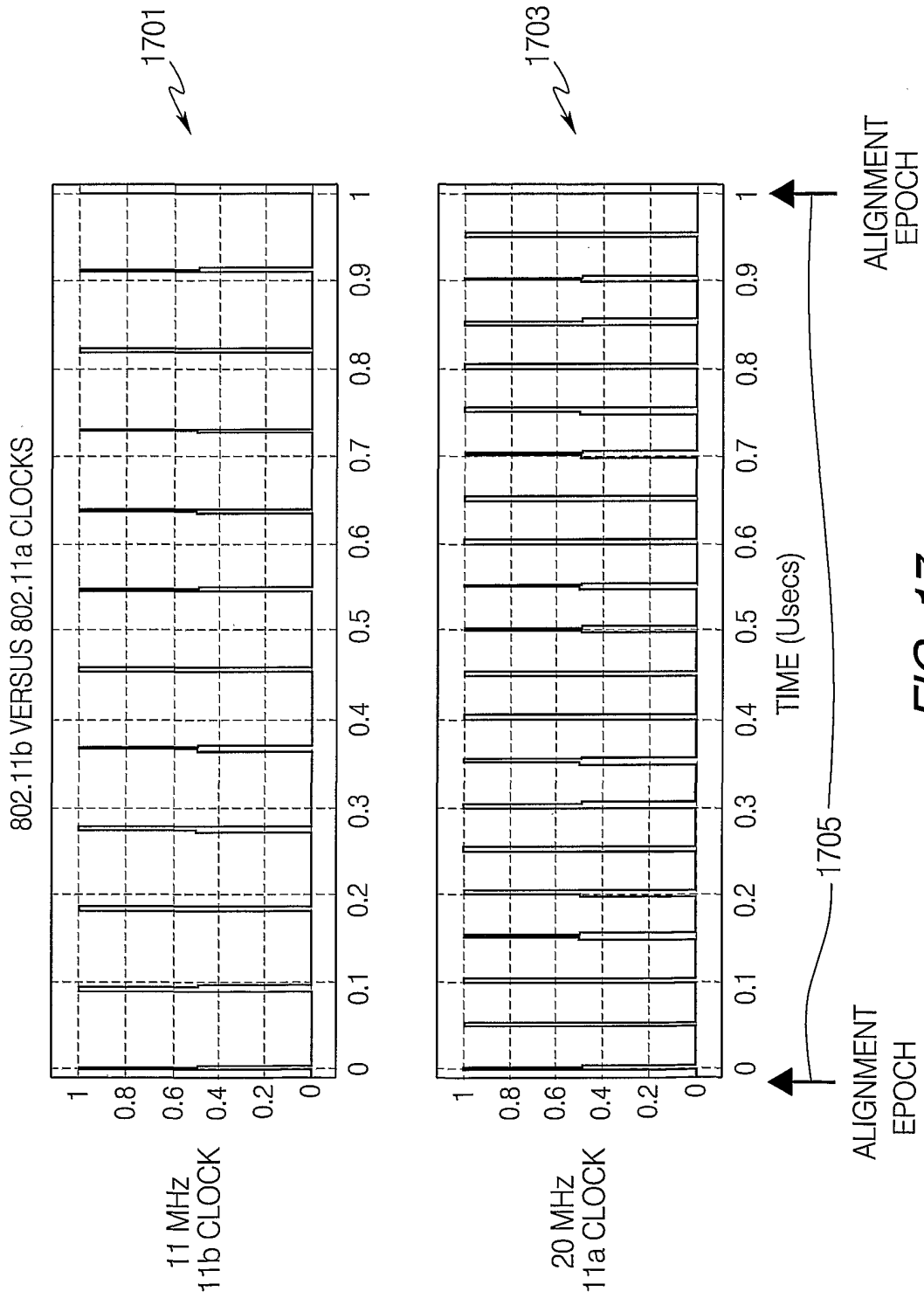

FIG. 17

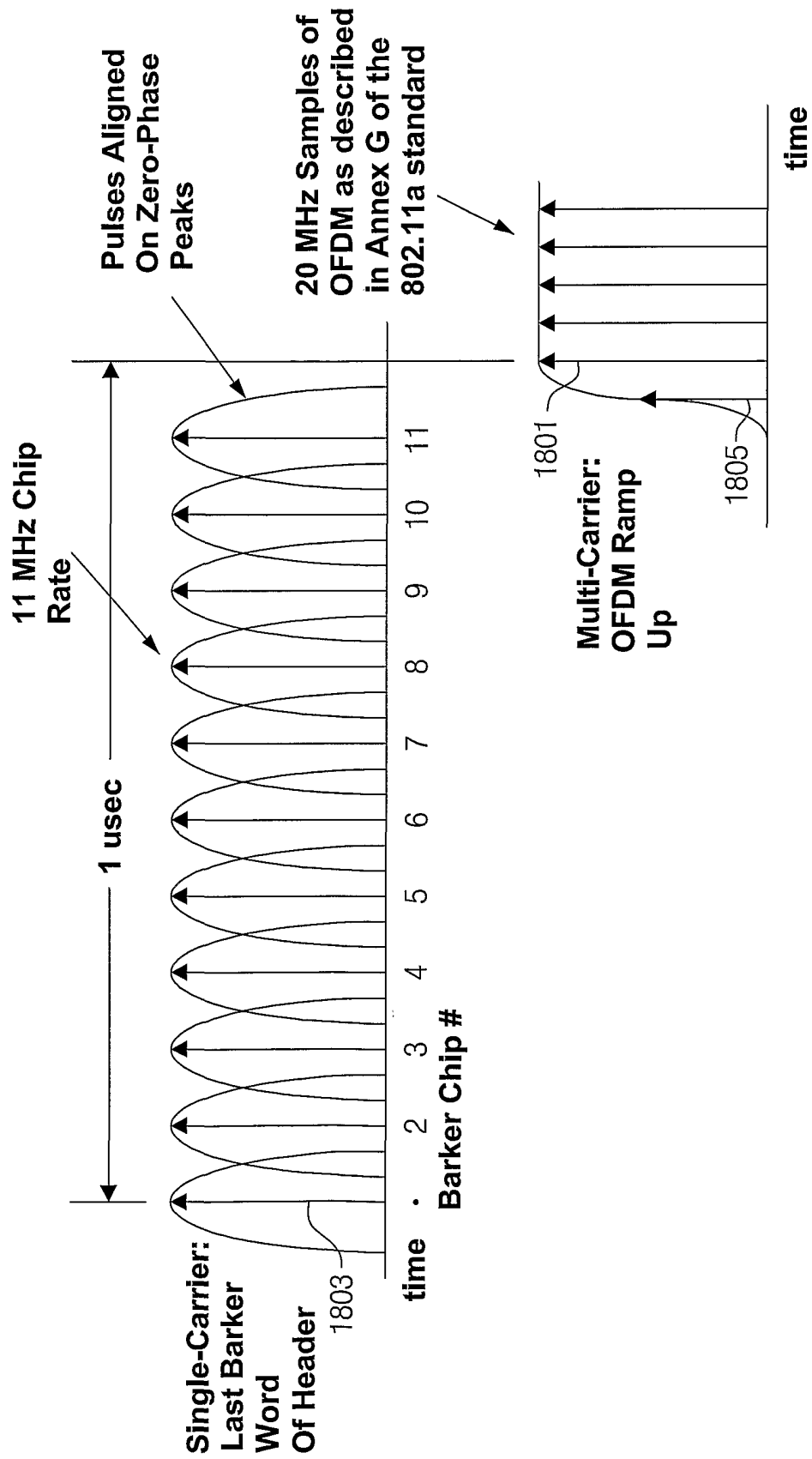

FIG. 18

15/18

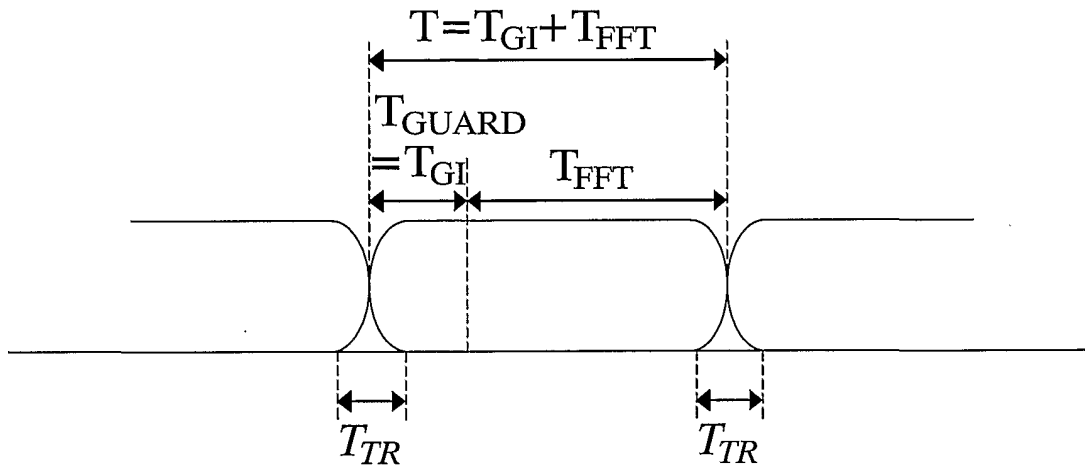

FIG. 19

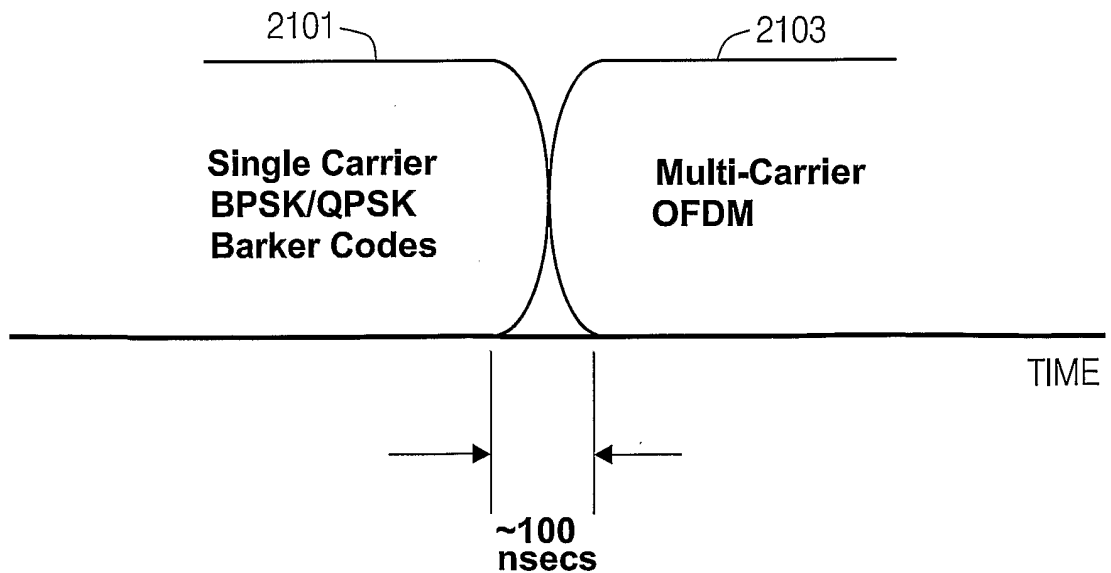

FIG. 21

$$w_T(t) = \sin^2 \left[ \frac{\pi}{2} \left( 0.5 + \frac{t}{T_{TR}} \right) \right] \text{ for } \left( -\frac{T_{TR}}{2} < t < \frac{T_{TR}}{2} \right)$$

$$w_T(t) = 1 \text{ for } \left( \frac{T_{TR}}{2} < t < T - \frac{T_{TR}}{2} \right)$$

$$w_T(t) = \sin^2 \left[ \frac{\pi}{2} \left( 0.5 - \frac{(t-T)}{T_{TR}} \right) \right] \text{ for } \left( T - \frac{T_{TR}}{2} < t < T + \frac{T_{TR}}{2} \right)$$

where  $T_{TR}$  is the Transition Duration

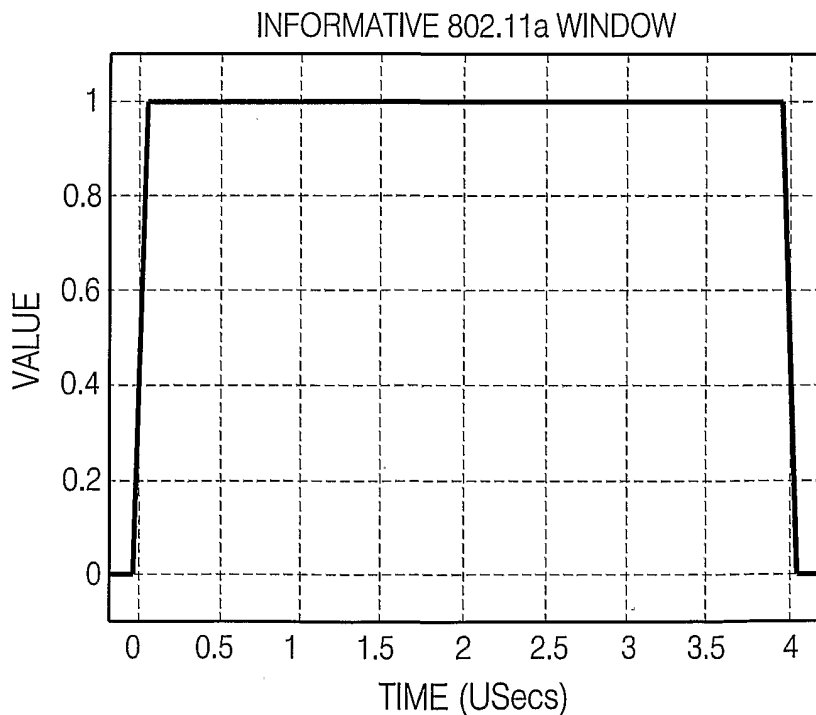
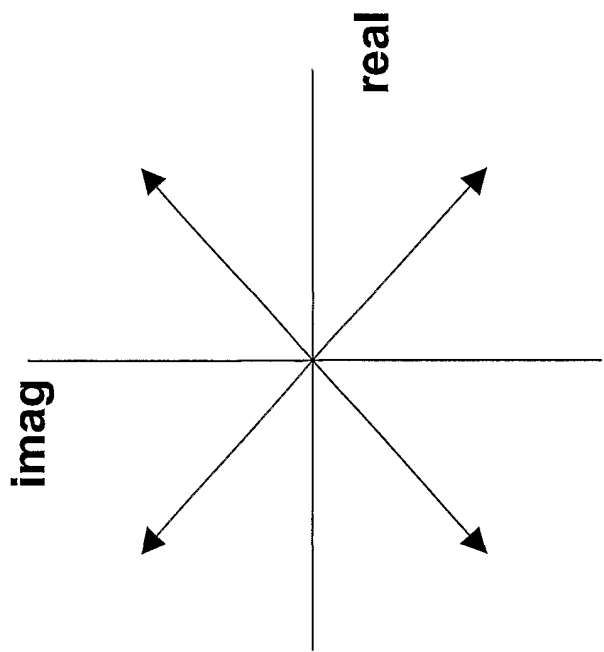

FIG. 20

**QPSK**



*FIG. 22B*

**BPSK**

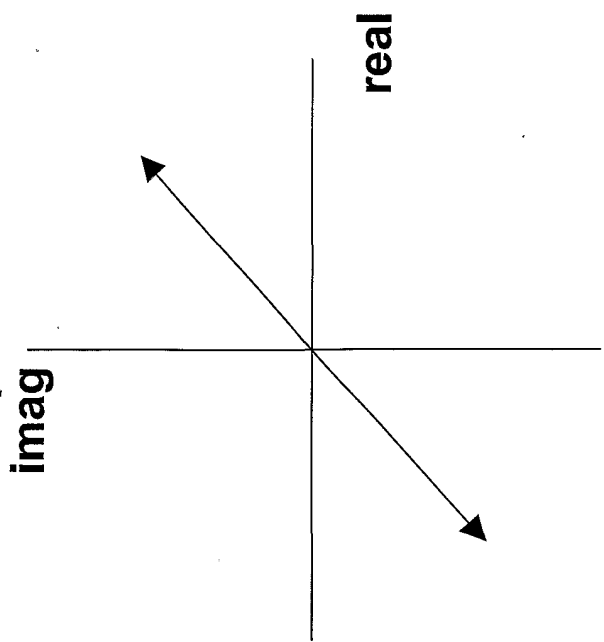

*FIG. 22A*

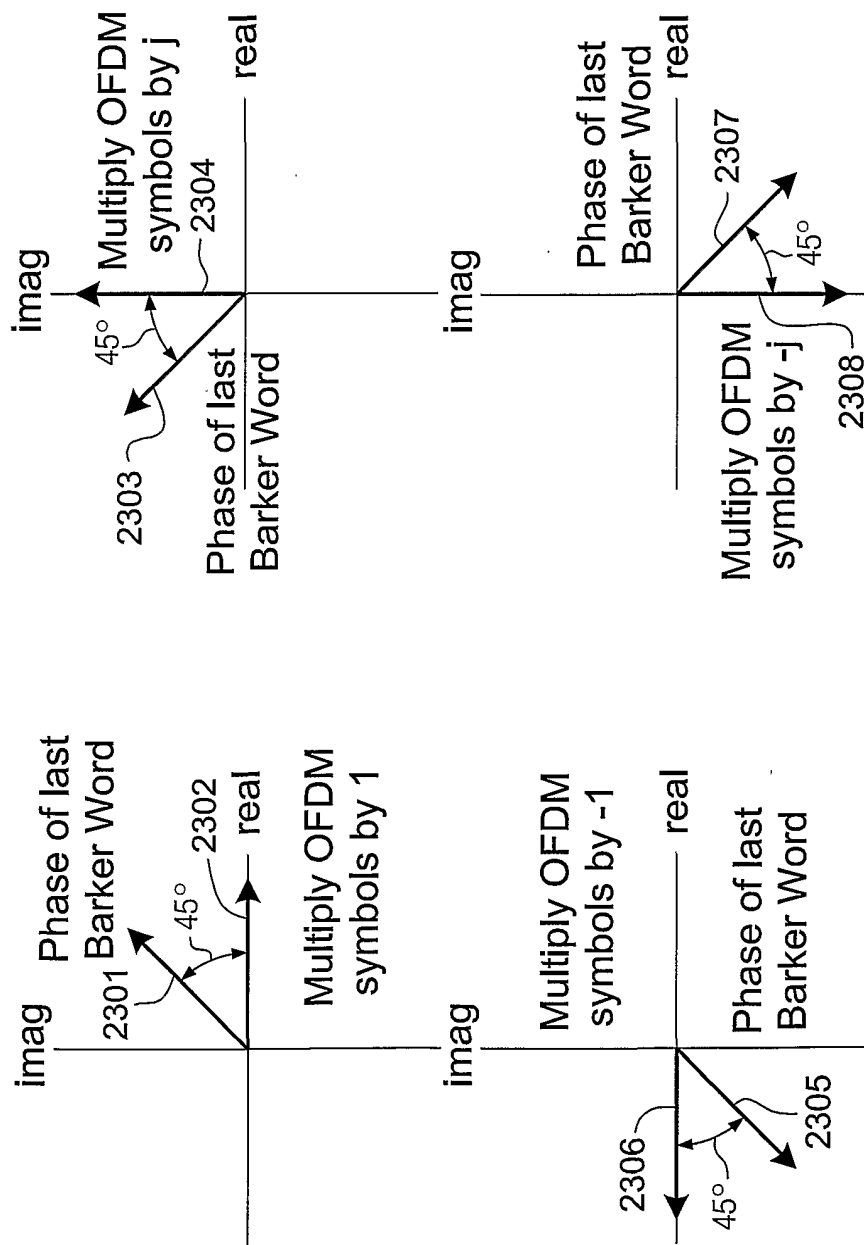

FIG. 23



# INTERNATIONAL SEARCH REPORT

International Application No  
PCT/US 02/21095

**A. CLASSIFICATION OF SUBJECT MATTER**  
IPC 7 H04L12/56 H04L12/28

According to International Patent Classification (IPC) or to both national classification and IPC

**B. FIELDS SEARCHED**

Minimum documentation searched (classification system followed by classification symbols)  
IPC 7 H04L

Documentation searched other than minimum documentation to the extent that such documents are included in the fields searched

Electronic data base consulted during the international search (name of data base and, where practical, search terms used)

EPO-Internal

**C. DOCUMENTS CONSIDERED TO BE RELEVANT**

Category °	Citation of document, with indication, where appropriate, of the relevant passages	Relevant to claim No.
X	<p>MARK WEBSTER, STEVE HALFORD: "Reuse of 802.11b Preambles with HRb OFDM" IEEE 802.11-00/390, 'Online!' 1 November 2000 (2000-11-01), pages 1-36, XP002217331 Retrieved from the Internet: &lt;URL:http://grouper.ieee.org/groups/802/11/Documents/DT351-400.html&gt; 'retrieved on 2002-10-18! page 12 page 15 page 24</p> <p style="text-align: center;">--- -/--</p>	1-23

Further documents are listed in the continuation of box C.

Patent family members are listed in annex.

° Special categories of cited documents:

- \*A\* document defining the general state of the art which is not considered to be of particular relevance
- \*E\* earlier document but published on or after the international filing date
- \*L\* document which may throw doubts on priority claim(s) or which is cited to establish the publication date of another citation or other special reason (as specified)
- \*O\* document referring to an oral disclosure, use, exhibition or other means
- \*P\* document published prior to the international filing date but later than the priority date claimed

- \*T\* later document published after the international filing date or priority date and not in conflict with the application but cited to understand the principle or theory underlying the invention
- \*X\* document of particular relevance; the claimed invention cannot be considered novel or cannot be considered to involve an inventive step when the document is taken alone
- \*Y\* document of particular relevance; the claimed invention cannot be considered to involve an inventive step when the document is combined with one or more other such documents, such combination being obvious to a person skilled in the art.
- \*Z\* document member of the same patent family

Date of the actual completion of the international search

18 October 2002

Date of mailing of the international search report

12/11/2002

Name and mailing address of the ISA  
European Patent Office, P.B. 5818 Patentlaan 2  
NL - 2280 HV Rijswijk  
Tel. (+31-70) 340-2040, Tx. 31 651 epo nl,  
Fax: (+31-70) 340-3016

Authorized officer  
  
Schneider, G

## INTERNATIONAL SEARCH REPORT

International Application No

PCT/US 02/21095

## C.(Continuation) DOCUMENTS CONSIDERED TO BE RELEVANT

Category °	Citation of document, with indication, where appropriate, of the relevant passages	Relevant to claim No.
X	<p>LAMBRETTE U ET AL: "OFDM BURST FREQUENCY SYNCHRONIZATION BY SINGLE CARRIER TRAINING DATA"            IEEE COMMUNICATIONS LETTERS, IEEE SERVICE CENTER, PISCATAWAY, US, US,            vol. 1, no. 2, 1 March 1997 (1997-03-01),            pages 46-48, XP000687090            ISSN: 1089-7798            the whole document</p>	1
A	<p>NEE VAN R ET AL: "NEW HIGH-RATE WIRELESS LAN STANDARDS"            IEEE COMMUNICATIONS MAGAZINE, IEEE SERVICE CENTER, PISCATAWAY, N.J, US,            vol. 37, no. 12, December 1999 (1999-12),            pages 82-88, XP000908328            ISSN: 0163-6804            the whole document</p>	
A	<p>"Supplement to IEEE standard for information technology - telecommunications and information exchange between systems - local and metropolitan area networks - specific requirements. Part 11: wireless LAN Medium Access Control (MAC) and Physical Layer (PHY) specifications: high-speed physical layer in"            IEEE STD 802.11A-1999, XX, XX,            30 December 1999 (1999-12-30), pages 1-90, XP002189725            cited in the application</p>	