

June 12, 1962

W. A. DE LONG

3,038,433

RUDDER MOUNTING FOR BOATS

Filed June 21, 1960

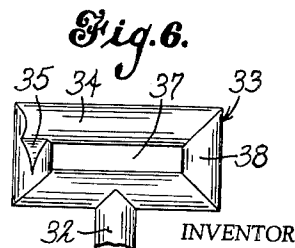
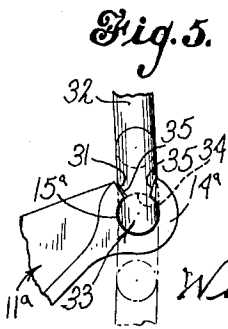
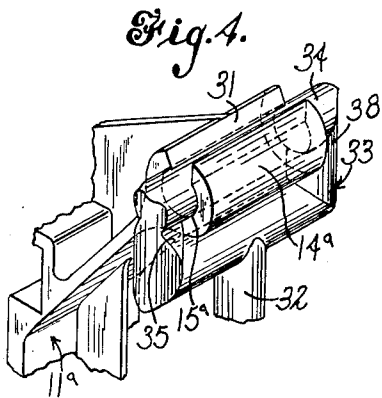
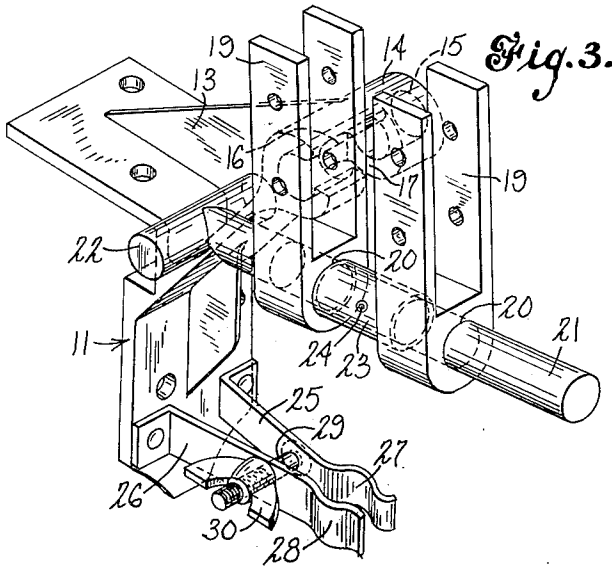
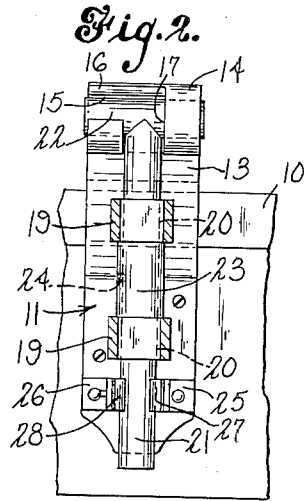
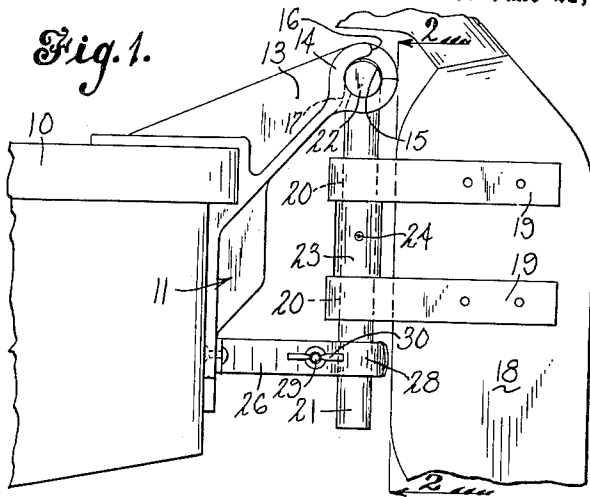

William A. De Long

BY *Richard B. Bartholomew*
ATTORNEYS

1

3,038,433

RUDDER MOUNTING FOR BOATS

William A. De Long, West Haven, Conn., assignor to Heldon Products, Inc., Prospect, Conn., a corporation of Connecticut

Filed June 21, 1960, Ser. No. 37,748

6 Claims. (Cl. 114-165)

This invention relates to a rudder mounting for boats and more particularly to a device for mounting the rudder at the stern of a boat whereby the rudder is mounted for swinging movement about a vertical axis and whereby the rudder may be attached to and detached from the boat by first swinging it upwardly about a horizontal axis and then moving it in a lateral or sidewise direction.

It is desirable in securing a rudder to a boat to provide for the ready detachment of the rudder from the boat when desired and also to so attach the rudder to the boat that, if an obstacle is encountered by the rudder, it may swing to a position to avoid the obstacle, thereby preventing damage to the rudder itself or to the structure by which it is mounted.

As illustrated in the present application, a bracket is secured to the stern portion of the boat, the bracket being provided with a sleeve having a through opening and the rudder being secured to a mounting member which may be attached to the sleeve member by a relative lateral movement of these two elements and a subsequent swinging movement about the axis of the sleeve member.

In one form of the invention the sleeve member is provided with an L-shaped opening communicating with the bore or through opening in this member. The rudder support is of T-shaped form so that when the leg or stem of the T-shaped member is brought into registration with the longitudinal portion of the L-shaped opening, the head of the T-shaped member may be inserted in the bore of the sleeve. Thereafter the leg of the T-shaped member may be rotated in the circumferential slot in the sleeve member so that accidental detachment of the two elements will be prevented.

In the other form of the invention the sleeve member provided upon the bracket secured to the boat is provided with a through bore and likewise a through longitudinal slot opening into the bore, while the rudder-supporting member is provided with a stem having on its upper end an open rectangular frame, the upper leg of which may be inserted into the bore of the sleeve member when the stem is in alignment with the through slot and thereafter this supporting member may be rotated to a position in which it will be held in place.

One object of the present invention is to provide new and improved means for securing a rudder to a boat.

Still another object of the invention is to provide means by which a rudder may be readily secured to a boat and readily detached therefrom and also releasably held in its operative position.

Still another object of the invention is to provide new and improved means for securing the rudder to a boat whereby the rudder may be attached to the boat by a lateral movement and a subsequent rotating movement in a plane transverse to the lateral movement and releasably secured in operative position.

To these and other ends the invention consists in the novel features and combinations of parts to be hereinafter described and claimed.

In the accompanying drawings:

FIG. 1 is a side elevational view of a rudder mounting embodying my invention;

FIG. 2 is a sectional view on line 2-2 of FIG. 1;

FIG. 3 is an exploded perspective view showing the parts of the device;

2

FIG. 4 is a fragmentary perspective view of the bracket secured to the boat and a rudder-supporting member of modified form;

FIG. 5 is a side elevational view of a portion of the bracket and a portion of the rudder-supporting member showing the method of assembly thereof; and

FIG. 6 is a front elevational view of the upper end of the rudder-supporting member.

To illustrate one embodiment of my invention I have shown in the drawings the stern portion of a boat 10 to which is rigidly secured a bracket 11. An arm 13 projects rearwardly from this bracket and is provided with a sleeve member 14 having a through bore 15.

The sleeve member 14 is provided with an L-shaped slot which communicates with the through bore 15. This slot comprises an axially directed or longitudinal portion 16 extending part way across the sleeve member, as shown in FIG. 2, and a circumferential portion 17 leading into the lateral portion 16.

Secured to the rudder 18 are a pair of clips or brackets 19 provided with openings 20. These brackets are secured to a T-shaped member comprising a stem or leg portion 21 and a transverse head portion 22, both of which may be circular shaped in cross section. The stem 21 of this member is inserted through the openings 20 of the brackets 19 and also through the bore of a sleeve 23 disposed between the brackets. This sleeve may be secured to the stem by a screw or similar fastening member 24 so that the rudder will be rotatably mounted upon the stem but prevented from longitudinal movement thereon.

Also secured to the bracket 11 or to the boat itself is a clamp member having arms 25 and 26 provided at their free ends with resilient jaws 27 and 28. A screw 29 is secured to one of the arms and passes loosely through and projects from the other arm to threadedly receive on its extended end a wing nut 30 to limit separation of the jaws.

The method of assembling the device is obvious from FIG. 3 of the drawings. The T-shaped member which supports the rudder will be placed in a position in which the head 22 registers with the bore 15 of the sleeve 14 and the stem registers with the longitudinal portion 16 of the L-shaped slot in the sleeve. This supporting member with the rudder attached thereto may then be moved laterally to insert the head 22 into the bore 15. At this time, as shown in FIG. 2, the stem will register with the circumferential portion 17 of the L-shaped slot in the sleeve and the rudder and T-shaped supporting member may then be rotated downwardly to the position shown in FIG. 1. The lower end of the stem will then be received and clamped between the jaws 27 and 28 and releasably held in place.

The tension on the jaws 27 and 28 may be regulated by the wing nut 30 so that when the rudder meets an obstruction which would be liable to injure or break it, it will be released from the clamping jaws and swung upwardly to a position to avoid the obstruction.

When it is desired to detach the rudder from the boat the operations will be reversed. The rudder will be swung upwardly, pulling the lower end of the stem 21 out of the clamping jaws and, when the stem registers with the longitudinal portion 16 of the L-shaped slot in the sleeve 14, the head 22 may be withdrawn from the sleeve to completely detach the rudder from the boat.

In the embodiment of the invention shown in FIGS. 4 to 6 the bracket 11^a secured to the stern of the boat is provided with a sleeve 14^a having a longitudinal bore 15^a. This sleeve is also provided with a through longitudinal or axially directed slot 31 opening into the bore 15^a. In this embodiment of the invention the rudder support or carrier is provided with a stem 32 corresponding to the stem 21 previously described and it will be understood that the rudder is secured to this stem in the

3

manner shown in FIGS. 1 to 3. The support is provided at the upper end of the stem 32 with an open rectangular transverse portion 33 having an upper leg 34 which, as will be explained, is adapted to be received in the bore 15^a of the sleeve 14^a. One of the sides of the member 33 is recessed, as shown at 35, adjacent its junction with the leg 34 so that at this point it is slightly reduced in width so that it may pass through the slot or opening 31 when the parts are assembled, as shown in FIG. 5.

It will be understood that the arm members 25 and 26 provided with the clamp 27 and 28 will also be provided in this instance upon the bracket 11^a to receive the lower end of the stem 32 as previously described.

When it is desired to attach the rudder to the boat, the supporting member is brought into such position that the leg 34 will register with the bore 15^a of the sleeve 14^a with the stem 32 in a substantially vertical position. At this time the recesses 35 will permit lateral movement of the supporting member with respect to the bracket 11^a so as to insert the leg 34 within the bore 15^a, as shown in FIG. 5, the sides of the slot 31 being sufficiently far apart to admit the reduced portion of the side of the frame member 33 between them. Thereafter, the rudder may be rotated downwardly through substantially 180 degrees, as shown in dotted lines in FIG. 5, the opening 37 in the rectangular frame 33 receiving the wall of the sleeve to permit this movement. The lower end of the stem will then be secured in the clamp member as before. Detachment of the rudder from the boat may be effected by performing these operations in reverse order.

It will be noted that in the embodiment of the invention first described, the insertion of the head 22 of the supporting member into the bore 15 of the sleeve 14 will be limited by the wall of the longitudinal portion 16 of the L-shaped recess so that the stem will correctly register with the circumferential portion 17 of the recess to permit rotation of the stem to its final position. In connection with the modification shown in FIGS. 4 to 6, insertion of the upper leg 34 will also be limited by engagement of the unreduced side 38 of the member 33 with the end wall of the sleeve 14^a and thus the parts will be properly positioned to permit rotation of the support to its final position.

While I have shown and described some preferred embodiments of my invention, it will be understood that it is not to be limited to all of the details shown, but is capable of modification and variation within the spirit of the invention and within the scope of the claims.

What I claim is:

1. Means for mounting a rudder upon a boat comprising a bracket adapted to be secured to the boat, said bracket comprising a sleeve member having an open-ended bore therein, said sleeve having a longitudinal slot in its wall communicating with the bore, a rudder support comprising a stem and a transverse member at one end of the stem, said transverse member being received in the bore by a sliding movement axially of the bore when the stem registers with said slot and then rotatable to a position to detachably secure the support to the bracket, and means for securing the rudder to the support.

2. Means for mounting a rudder upon a boat comprising a bracket adapted to be secured to the boat, said bracket comprising a sleeve member having an open-

4

ended bore therein, a T-shaped rudder support having a stem and a transversely extending head at one end thereof, said sleeve having an L-shaped slot in the wall thereof having an axial portion opening through one end of the sleeve member and a circumferential portion, said head being received in the bore of said sleeve when the stem registers with the axial portion of the slot and thereafter rotatable to position the stem in the circumferential part of the slot to detachably secure the support to the sleeve, and means for attaching the rudder to the support.

3. Means for mounting a rudder upon a boat as set forth in claim 1 wherein the longitudinal slot extends inwardly from one end of the sleeve member and terminates short of the other end, and a circumferential slot is provided in the sleeve member which communicates with the longitudinal slot and permits rotation of the stem to its final position.

4. Means for mounting a rudder upon a boat comprising a bracket adapted to be secured to the boat, said bracket comprising a sleeve member having an open-ended bore therein, said sleeve having a longitudinal slot in its wall communicating with the bore, a rudder support comprising a stem and a transverse member at one end of the stem, said transverse member being received in the bore by a sliding movement axially of the bore when the stem registers with said slot and then rotatable to a position to detachably secure the support to the bracket, means for securing the rudder to the support, and clamping means on said bracket to receive the stem and releasably secure it in place.

5. Means for mounting a rudder upon a boat comprising a bracket adapted to be secured to the boat, said bracket comprising a sleeve member having an open-ended bore therein, said sleeve having a longitudinal slot in its wall communicating with the bore, a rudder support comprising a stem and a transverse member at one end of the stem, said transverse member being received in the bore by a sliding movement axially of the bore when the stem registers with said slot and then rotatable to a position to detachably secure the support to the bracket, means for securing the rudder to the support, and means on said bracket providing resilient clamping jaws to receive said stem and releasably secure the rudder in place.

6. Means for mounting a rudder upon a boat comprising a bracket adapted to be secured to the boat, said bracket comprising a sleeve member having an open-ended bore therein, said sleeve having a longitudinal slot in its wall communicating with the bore, a rudder support comprising a stem and a transverse member at one end of the stem, said transverse member being received in the bore by a sliding movement axially of the bore and said transverse member being the upper leg of an open rectangular frame secured to the stem, said slot being co-extensive in length with the sleeve member so that when the stem registers with said slot and then is rotated, the support is detachably secured to the bracket, and means for securing the rudder to the support.

References Cited in the file of this patent

UNITED STATES PATENTS

2,911,935 Brown ----- Nov. 10, 1959