



- (51) **International Patent Classification:**
A47C 1/02 (2006.01)
- (21) **International Application Number:**
PCT/US20 13/020273
- (22) **International Filing Date:**
4 January 2013 (04.01.2013)
- (25) **Filing Language:** English
- (26) **Publication Language:** English
- (30) **Priority Data:**
13/344,215 5 January 2012 (05.01.2012) US
- (71) **Applicant:** L & P PROPERTY MANAGEMENT COMPANY [US/US]; 4095 Firestone Boulevard, South Gate, CA 90280 (US).
- (72) **Inventor:** LAWSON, Gregory, Mark; c/o L & P Property Management Company, 4095 Firestone Boulevard, South Gate, CA 90280 (US).
- (74) **Agents:** TABOR, Benjamin, P. et al; Shook, Hardy & Bacon LLP, 2555 Grand Boulevard, Kansas City, MS 64108 (US).
- (81) **Designated States** (unless otherwise indicated, for every kind of national protection available): AE, AG, AL, AM, AO, AT, AU, AZ, BA, BB, BG, BH, BN, BR, BW, BY, BZ, CA, CH, CL, CN, CO, CR, CU, CZ, DE, DK, DM,

DO, DZ, EC, EE, EG, ES, FI, GB, GD, GE, GH, GM, GT, HN, HR, HU, ID, IL, IN, IS, JP, KE, KG, KM, KN, KP, KR, KZ, LA, LC, LK, LR, LS, LT, LU, LY, MA, MD, ME, MG, MK, MN, MW, MX, MY, MZ, NA, NG, NI, NO, NZ, OM, PA, PE, PG, PH, PL, PT, QA, RO, RS, RU, RW, SC, SD, SE, SG, SK, SL, SM, ST, SV, SY, TH, TJ, TM, TN, TR, TT, TZ, UA, UG, UZ, VC, VN, ZA, ZM, ZW.

(84) **Designated States** (unless otherwise indicated, for every kind of regional protection available): ARIPO (BW, GH, GM, KE, LR, LS, MW, MZ, NA, RW, SD, SL, SZ, TZ, UG, ZM, ZW), Eurasian (AM, AZ, BY, KG, KZ, RU, TJ, TM), European (AL, AT, BE, BG, CH, CY, CZ, DE, DK, EE, ES, FI, FR, GB, GR, HR, HU, IE, IS, IT, LT, LU, LV, MC, MK, MT, NL, NO, PL, PT, RO, RS, SE, SI, SK, SM, TR), OAPI (BF, BJ, CF, CG, CI, CM, GA, GN, GQ, GW, ML, MR, NE, SN, TD, TG).

Declarations under Rule 4.17:

- as to applicant's entitlement to apply for and be granted a patent (Rule 4.1 7(H))
- as to the applicant's entitlement to claim the priority of the earlier application (Rule 4.1 7(in))

Published:

- with international search report (Art. 21(3))

(54) **Title:** ZERO-WALL CLEARANCE LINKAGE MECHANISM FOR A LIFTING RECLINER

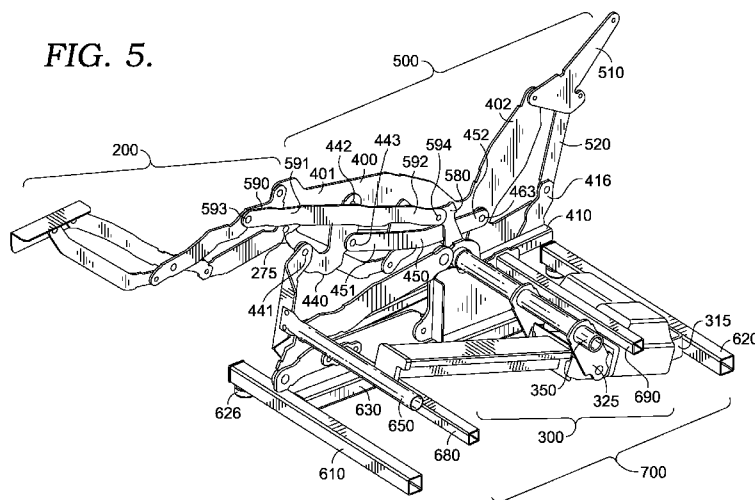

(57) **Abstract:** A seating unit that includes a linkage mechanism adapted to move the seating unit between closed, extended, reclined, and seat-lift positions is provided. The linkage mechanism includes a footrest assembly and a back-mounting link coupled to a seat-mounting plate, a base plate coupled to a lift-base assembly via a lift assembly, a seat-adjustment assembly including a drive bracket, and a linear actuator for automating adjustment of the linkage mechanism. In operation, a stroke in a first phase of the linear actuator rotates the drive bracket a first angular increment causing the seat-adjustment assembly to bias the seat-mounting plate. A stroke in a second phase rotates the drive bracket a second angular increment causing the footrest assembly to extend or retract without affecting the bias of the back-mounting link. A stroke in a third phase causes the lift assembly to raise and tilt the base plate directly over the lift-base assembly.



ZERO-WALL CLEARANCE LINKAGE MECHANISM FOR A LIFTING RECLINER

BACKGROUND OF THE INVENTION

The present invention relates broadly to motion upholstery furniture designed to support a user's body in an essentially seated disposition. Motion upholstery furniture includes recliners, incliners, sofas, love seats, sectionals, theater seating, traditional chairs, and chairs with a moveable seat portion, such furniture pieces being referred to herein generally as "seating units." More particularly, the present invention relates to an improved linkage mechanism developed to accommodate a wide variety of styling for a seating unit, which is otherwise limited by the configurations of linkage mechanisms in the field. Additionally, the improved linkage mechanism of the present invention provides for reclining a seating unit that is positioned against a wall or placed within close proximity of other fixed objects.

Reclining and lifting seating units exist that allow a user to forwardly extend a footrest, to recline a backrest rearward relative to a seat, and to lift the seat for accommodating easy ingress and egress thereof. These existing seating units typically provide three basic positions (e.g., a standard, nonreclined closed position; an extended position; and a reclined position), and a seat-lift position as well. In the closed position, the seat resides in a generally horizontal orientation and the backrest is disposed substantially upright. Additionally, if the seating unit includes an ottoman attached with a mechanical arrangement, the mechanical arrangement is collapsed such that the ottoman is not extended. In the extended position, often referred to as a television ("TV") position, the ottoman is extended forward of the seat, and the backrest remains sufficiently upright to permit comfortable television viewing by an occupant of the seating unit. In the reclined position the backrest is pivoted rearward from the extended position into an obtuse relationship with the seat for lounging or sleeping. In the seat-lift position, the recliner mechanism is typically adjusted to the closed position and a lift assembly raises and tilts forward the seating unit in order to facilitate entry thereto and exit therefrom.

Several modern seating units in the industry are adapted to provide the adjustment capability described above. However, these seating units require relatively complex linkage mechanisms to afford this capability. The complex linkage assemblies limit

certain design aspects when incorporating automation. In particular, the geometry of these linkage assemblies impose constraints on incorporating or mounting a single motor thereto. Such constraints include the motor, during extension and/or retraction when adjusting between the positions mentioned above, interfering with crossbeams, the underlying surface, or moving parts attached to the linkage assembly. Accordingly, two or more motors with substantially extensive strokes are generally required to accomplish automating a full range of motion of a lifter-recliner seating unit. In view of the above, a more refined linkage mechanism that achieves full movement when being automatically adjusted between the closed, extended, reclined, and even seat-lift positions would fill a void in the current field of motion-upholstery technology. Accordingly, embodiments of the present invention pertain to a novel linkage mechanism that is constructed in a simple and refined arrangement in order to provide suitable function while overcoming the above-described, undesirable features inherent within the conventional complex linkage mechanisms.

SUMMARY OF THE INVENTION

Embodiments of the present invention seek to provide a simplified lifter-recliner linkage mechanism that can be assembled to a single compact motor and that can be adapted to essentially any style of seating unit. In an exemplary embodiment, the compact motor in concert with the linkage mechanism can achieve full movement and sequenced adjustment of the seating unit when being automatically adjusted between the closed, extended, reclined, and seat-lift positions. The compact motor may be employed in a proficient and cost-effective manner to adjust the linkage mechanism without creating interference or other disadvantages appearing in the conventional designs that are inherent with automation thereof. The linkage mechanism may be configured with features that assist in sequencing the seating-unit adjustment between positions, maintaining a seat in a substantially consistent location during the seating-unit adjustment, and curing other disadvantages appearing in the conventional designs.

Generally, the lifter-recliner seating unit includes the following components: foot-support ottoman(s); a pair of base plates in substantially parallel-spaced relation; a pair of lift assemblies and at least one crossbeam spanning the lift assemblies; a lift-base assembly coupled to the lift assemblies via the lift assemblies; a pair of seat-mounting plates in substantially parallel-spaced relation; and a pair of the generally mirror-image linkage

mechanisms that interconnect the base plates to the seat-mounting plates. In operation, the linkage mechanisms are adapted to move between a seat-lift position, a closed position, an extended position, and a reclined position, while the lift assemblies are adapted to move the linkage mechanisms into and out of a seat-lift position.

5 In one embodiment, the linkage mechanisms include a footrest assembly that extends and retracts at least one foot-support ottoman and a seat-adjustment assembly that reclines and inclines the backrest. Further, the lifter-recliner seating unit may include a linear actuator that provides automated adjustment of the seating unit between the closed position, the extended position, the reclined position, and the seat-lift position. Typically, the linear
10 actuator is configured to move the lift assemblies into and out of the seat-lift position while maintaining the linkage mechanisms in the closed position and while consistently maintaining the seat-mounting plates inside a footprint of the lift-base assembly.

 In another embodiment, each of the linkage mechanisms includes a cam control link, a sequence cam, and a sequence element. The cam control link includes a front
15 end and a rear end, where the front end of the cam control link is pivotably coupled with the footrest assembly. The sequence cam includes a contact edge and is rotatably coupled to the seat-mounting plate, where the rear end of the cam control link is pivotably coupled to the sequence cam. The sequence element extends outwardly, in a substantially perpendicular manner, from a respective linkage mechanism. In operation, during first-phase adjustment,
20 the contact edge of the sequence cam is removed from the sequence element, thereby allowing the seat-adjustment assembly to recline the backrest. Alternatively, during second-phase adjustment, the contact edge of the sequence cam is adjacent to the sequence element, thereby physically preventing the seat-adjustment assembly from reclining the backrest while the footrest assembly extends the at least one foot-support ottoman. In this way, interaction
25 of the sequence element with the contact edge (i.e., one or more exterior walls) of the sequence cam resists adjustment of the linkage mechanisms directly between the closed and reclined positions. For example, when moving from the closed position to the extended position, the backrest is restrained from inadvertently reclining. In another example, when moving from the reclined position to the extended position, the footrest assembly is restrained
30 from inadvertently extending.

 In yet another embodiment, the seating unit includes a linear actuator that provides automated adjustment of the linkage mechanisms between the closed position, the extended position, the reclined position, and the seat-lift position. Generally, the linear-

actuator adjustment is sequenced into a first phase, a second phase, and a third phase that are mutually exclusive in stroke. In one instance, the first phase moves the seat-adjustment assembly between the reclined position and the extended position, the second phase moves the footrest assembly between the extended position and the closed position, and the third
5 phase moves the pair of lift assemblies into and out of the seat-lift position, while maintaining the linkage mechanisms in the closed position.

In an exemplary embodiment, each of the linkage mechanisms includes a footrest drive link and a footrest drive bracket. The footrest drive bracket is fixedly attached to one of the ends of an activator shaft. The footrest drive link that includes a front end and a
10 back end, where the footrest drive bracket is pivotably coupled to the back end of the footrest drive link and the front end of the footrest drive link is pivotably coupled to the footrest assembly. Typically, the activator shaft spans between and couples to the linkage mechanisms. In one instance, the activator shaft is configured with a pair of ends, where one of the ends of the activator shaft is rotatably coupled to a respective base plate via an
15 activator mounting plate.

Generally, the linear actuator includes the following components: a motor mechanism; a track operably coupled to the motor mechanism; and a motor activator block that translates longitudinally along the track under automated control. In instances, the track includes a first travel section, a second travel section, and a third travel section. In operation,
20 during the first phase, the motor activator block longitudinally translates along the first travel section, thereby causing the activator shaft to rotate and, consequently, causing the footrest drive bracket to rotate over a first angular increment of rotation. This first angular increment of rotation translates the footrest drive link rearward, generating a lateral pull against the footrest assembly that invokes the seat-adjustment assembly to adjust from the reclined
25 position and the extended position.

During the second phase, the motor activator block longitudinally translates along the second travel section, thereby causing the activator shaft to rotate again and, consequently, causing the footrest drive bracket to rotate over a second angular increment of rotation. This second angular increment of rotation translates the footrest drive link rearward,
30 generating another lateral pull against the footrest assembly that invokes the footrest assembly to adjust from the extended position and the closed position. Typically, the first angular increment includes a range of degrees of angular rotation that does not intersect a range of degrees included within the second angular increment.

Last, during the third phase, the motor activator block longitudinally translates along the third travel section, thereby creating a lateral thrust at the activator shaft. Because, at this point, the activator shaft is prevented from further rotation as a result of a detent condition of the linkage mechanism in the closed position (e.g., the footrest drive bracket contacting an upper surface of the base plate), this longitudinal translation within the third travel section invokes adjustment of the lift assemblies into or out of the seat-lift position, while maintaining the linkage mechanisms in the closed position. This adjustment to the seat-lift position causes the seat-mounting plate to ascend and tilt with respect to the lift-base assembly while, at the same time, remain within the lift-base assembly's footprint on an underlying surface. As such, embodiments of the present invention introduce a single linear actuator that is configured to controllably adjust the linkage mechanisms of a seating between the four positions above in a sequential or continuous manner.

BRIEF DESCRIPTION OF THE DRAWING

In the accompanying drawings, which form a part of the specification and which are to be read in conjunction therewith, and in which like reference numerals are used to indicate like parts in the various views:

FIG. 1 is a diagrammatic lateral view of a seating unit in a closed position, in accordance with an embodiment of the present invention;

FIG. 2 is a view similar to FIG. 1, but in an extended position, in accordance with an embodiment of the present invention;

FIG. 3 is a view similar to FIG. 1, but in a reclined position, in accordance with an embodiment of the present invention;

FIG. 4 is a view similar to FIG. 1, but in a seat-lift position, in accordance with an embodiment of the present invention;

FIG. 5 is a perspective view of a linkage mechanism in the reclined position illustrating a linear actuator for providing motorized adjustment of the seating unit, in accordance with an embodiment of the present invention;

FIG. 6 is a view similar to FIG. 5, but in the seat-lift position, in accordance with an embodiment of the present invention;

FIG. 7 is a diagrammatic lateral view of the linkage mechanism in the closed position from a vantage point external to the seating unit, in accordance with an embodiment of the present invention;

FIG. 8 is a view similar to FIG. 7, but in the extended position, in accordance
5 with an embodiment of the present invention;

FIG. 9 is a view similar to FIG. 7, but in the reclined position, in accordance with an embodiment of the present invention; and

FIG. 10 is a view similar to FIG. 7, but in the seat-lift position, in accordance with an embodiment of the present invention.

10

DETAILED DESCRIPTION OF THE INVENTION

The subject matter of embodiments of the present invention is described with specificity herein to meet statutory requirements. However, the description itself is not intended to limit the scope of this patent. Rather, the inventors have contemplated that the claimed subject matter might also be embodied in other ways, to include different steps or
15 combinations of steps similar to the ones described in this document, in conjunction with other present or future technologies.

Generally, embodiments of this invention introduce technology within the motion furniture industry to improve operation and styling of a lifter-recliner-type seating unit. In embodiments, the operational improvements include: configuring linkage
20 mechanisms of the seating unit to maintain a seat and backrest directly above the lift assembly throughout adjustment; designing the linkage mechanisms to attach to a lift-base assembly via one attachment point per side; and employing a straight tube to serve as a majority of the base plate, thereby minimizing weight and material. In embodiments, the styling improvements include: attaching lift links of the lift assembly directly to the linkage
25 mechanisms, respectively, in order to increase stability of the seating unit; and reorganizing attachment points interconnecting links comprising the linkage mechanisms, thereby allowing for such styling features as T-cushion seating. These above-listed improvements, as well as various others, will become evident within the description below and the accompanying drawings.

30

FIGS. 1-4 illustrate a seating unit 10. Seating unit 10 has a seat 15, a backrest 25, legs 26 (e.g., floor-support bushings or a lift-base assembly 600 that rests upon an

underlying surface), at least one linkage mechanism 100, at least one lift assembly 700, a motor assembly 300, at least one foot-support ottoman 45, a stationary base 35 or chassis, and a pair of opposed arms 55. Stationary base 35 has a forward section 52, a rearward section 54, and is supported by the legs 26 or the lift-base assembly 600 (see FIG. 5), which
5 vertically suspends the stationary base 35 above the underlying surface (not shown). In addition, the stationary base 35 is interconnected to the seat 15 via the linkage mechanism(s) 100 that are generally disposed between the pair of opposed arms 55 and the rearward section 54. Seat 15 remains generally fixed in location over the stationary base 35 during adjustment of the seating unit 10, or when raising or lowering the seating unit 10 into or out of a seat-lift
10 position (see FIG. 6). In embodiments, the seat 15 and/or the backrest 25 is moveable according to the arrangement of the linkage mechanism 100 such that interference between the seat 15/backrest 25 and the opposed arms 55 is prevented throughout adjustment.

Opposed arms 55 are laterally spaced and have an arm-support surface 57 that is typically substantially horizontal. In one embodiment, the pair of opposed arms 55 are
15 attached to the stationary base 35 via intervening members. The backrest 25 extends from the rearward section 54 of the stationary base 35 and is rotatably coupled to the linkage mechanism(s) 100, typically proximate to the arm-support surface 57. Foot-support ottoman(s) 45 are moveably supported by the linkage mechanism(s) 100. The linkage mechanism(s) 100 are arranged to articulately actuate and control movement of the seat 15,
20 the back 25, and the ottoman(s) 45 between the positions shown in FIGS. 1-3, as more fully described below. In addition, when the linkage mechanism 100 is adjusted to the closed position (see FIG. 3), the lift assembly 700 is configured to adjust the seating unit 10 into and out of the seat-lift position (see FIG. 4).

As shown in FIGS. 1-4, the seating unit 10 is adjustable to four positions: a
25 closed position 20, an extended position 30 (i.e., TV position), the reclined position 40, and the seat-lift position 50. FIG. 1 depicts the seating unit 10 adjusted to the closed position 20, which is a normal nonreclined sitting position with the seat 15 in a generally horizontal position and the backrest 25 generally upright and generally perpendicular to the seat 15. In one embodiment, the seat 15 is disposed in a slightly inclined orientation relative to the
30 stationary base 35. In this embodiment, the inclined orientation may be maintained throughout adjustment of the seating unit 10 due to the novel configuration of the linkage mechanism(s) 100. Further, when adjusted to the closed position 20, the foot-support ottoman(s) 45 are positioned below the seat 15.

Turning to FIG. 2, the extended position 30, or TV position, will now be described. When the seating unit 10 is adjusted to the extended position 30, the foot-support ottoman(s) 45 are extended forward of the forward section 52 of the stationary base 35 and disposed in a generally horizontal orientation. However, the backrest 25 remains substantially perpendicular to the seat 15 and will not encroach an adjacent wall. Also, the seat 15 is maintained in the inclined orientation relative to the stationary base 35. Typically, the seat 15 is not translated forward, backward, downward, or upward relative to the stationary base 35. Thus, the configuration of the seating unit 10 in the extended position 30 provides an occupant an inclined TV position while providing space-saving utility. This lack of independent movement of the seat 15, with respect to the opposed arms 55, allows for a variety of styling to be incorporated into the seat 15, such as T-cushion styling.

FIG. 3 depicts the reclined position 40, in which the seating unit 10 is fully reclined. Typically, the backrest 25 is rotated rearward by the linkage mechanism 100 and biased in a rearward inclination angle. The rearward inclination angle is typically an obtuse angle in relation to the seat 15. However, the rearward inclination angle of the backrest 25 is offset by a slight-to-negligible forward and upward translation of the seat 15 as controlled by the linkage mechanism 100. This is in contrast to other reclining chairs with 3- or 4-position mechanisms, which cause their backrest to move rearward during adjustment, thereby requiring that the reclining chair be positioned a considerable distance from an adjacent rear wall or other proximate fixed objects. Thus, the general lack of translation of the seat 15 in embodiments of the present invention allows for zero-wall clearance. Generally, the "zero-wall clearance" is utilized herein to refer to a space-saving utility that permits positioning the seating unit 10 in close proximity to an adjacent rear wall and other fixed objects behind the seating unit. In embodiments of the reclined position 40, the foot-support ottoman(s) 45 may be moved slightly upward, but not translated forward or rearward, from their position in the extended position 30.

Turning to FIG. 4, the seat-lift position 50, will now be described. When the seating unit 10 is adjusted to the seat-lift position 50, the linkage mechanism(s) 100 are maintained in the closed position 20 of FIG. 1, but raised upward and tilted forward to assist with an occupant's ingress to and egress from the seating unit 10. In an exemplary embodiment, the lift assemblies 700 are employed to raise and tilt the linkage mechanism(s) 100, as well as the seating-unit components attached thereto, with respect to the lift-base assembly 600. In one instance, adjustment of the lift assembly 700 may be automated

through use of the linear actuator within the motor assembly 300. Typically, the linear actuator is utilized to adjust the linkage mechanism 100 between the closed, extended, and reclined positions as well.

In embodiments, lift links 720 and 730 of the lift assembly 700 are pivotably
5 coupled to a riser connector plate 710 at connection points 741 and 742, respectively. The pivotable coupling of the lift links 720 and 730 at the connection points 741 and 742 may be made via rivets, which greatly reduce material cost, assembly labor time, and allow for a much greater separation of the left- and right-side lift links. This widened separation between the lift links 720 and 730 and the opposed lift links (not shown) substantially increases the
10 stability of the seating unit 10.

Further, the links 710, 720, and 730 of the lift assembly 700 may be initially incorporated within the linkage mechanism 100, while the lift-base assembly 600 is initially assembled separately. In embodiments, the linkage mechanism 100 is mounted to the lift-base assembly 600 at connection point 743, which fixedly attaches the riser connector plate
15 710 of the lift assembly to a lift bracket 740 that is typically welded to the lift-base assembly 600. In this way, the connection point 743 allows for linkage mechanism 100 to be attached to the lift-base assembly 600 with only one fastener (e.g., shoulder bolt). Thus, the assembly process of attaching the linkage mechanism 100 to the lift-base assembly 600 is simplified and can be easily performed prior to shipping on the fabrication facility or subsequent to
20 shipping on the premise of a seating-unit manufacturer. By attaching the linkage mechanism 100 to the lift-base assembly 600 after shipping, the freight costs are reduced as the components may be packaged individually in order to minimize cargo space being utilized.

As can be seen, the lack of translation of the seat 15 during the adjustment between the closed position 20, extended position 30, reclined position 40, and the seat-lift
25 position 50, enables the seat 15 to remain substantially in place directly over lift-base assembly 600. This lack of translation is caused by the geometry of the linkage mechanism 100. This geometry accommodates an innovative single-motor design (see FIGS. 5 and 6) that allows the seating unit 10 to remain positioned directly over a perimeter of the lift-base assembly 600 (e.g., hovering over a profile established by the adjoining structural elements
30 that form a foundation of the seating unit) through each adjustment of the seating unit 10. Specifically, as will be demonstrated later via FIGS. 7-10, the linkage mechanism 100 prevents the seat 15 from shifting rearward as the footrest assembly 200 extends. Instead, upon adjusting from the closed position 20 to the extended position 30, the seat 15 moves

generally upward and slightly forward, thereby acting to recline the seating unit 10. In this way, the lifting of the seat 15 helps to balance the reclining movement of a seating-unit occupant's weight.

Moreover, this consistent lateral positioning (i.e., insignificant fore or aft
5 movement of the seat) provides furniture manufacturers the ability to offer a full enclosure of both the linkage mechanism 100 and the lift-base assembly 600, thereby providing full protection of articulating linkages when the seating unit 10 is adjusted to the seat-lift position 50. In contrast, conventional single-motor designs translate the seat forward or rearward during adjustment such that the seat 15 moves outside a perimeter of the lift-base assembly
10 600. In particular examples, these conventional designs either move their seat rearward when reclining (e.g., push-on-the-arm style chairs) or move their seat forward (e.g., traditional wall-avoiding style chairs).

Turning to FIGS. 5-10, exemplary configurations of a linkage mechanism 100
for a lifter-recliner-type seating unit 10 (hereinafter "seating unit") that is powered by a linear
15 actuator included within the motor assembly 300 are illustrated and will now be discussed. With initial reference to FIG. 5, a perspective view of the linkage mechanism 100 in the reclined position is shown, in accordance with an embodiment of the present invention. In embodiments, the linkage mechanism 100 includes a footrest assembly 200, a seat-mounting plate 400, a base plate 410, a seat-adjustment assembly 500, the lift-base assembly 600, and
20 the lift assembly 700. The footrest assembly 200 is comprised of a plurality of links arranged to extend and collapse the ottoman(s) (e.g., foot-support ottoman 45 of FIGS. 1-4) during adjustment of the seating unit between the extended position and the closed position, respectively. The seat-mounting plate 400 is configured to fixedly mount to the seat of the
25 seating unit and, in conjunction with an opposed seat-mounting plate, defines a seat support surface (not shown). Generally, the seat-adjustment assembly 500 is adapted to recline and incline the backrest of the seating unit, which is coupled to a back-mounting link 510 of the seat-adjustment assembly 500. Further, the seat-adjustment assembly 500 includes links (e.g., activator mounting plate 360) that indirectly couple a single-motor linear actuator of the
30 motor assembly 300 to the base plate 410, thereby facilitating lifting movement of the seat upon actuation of the linear actuator.

Further, the linkage mechanism 100 comprises a plurality of linkages that are arranged to actuate and control movement of the seating unit during adjustment between the closed, the extended, and the reclined position. These linkages may be pivotably

interconnected. It is understood and appreciated that the pivotable couplings (illustrated as pivot points in the figures) between these linkages can take a variety of configurations, such as pivot pins, bearings, traditional mounting hardware, rivets, bolt and nut combinations, or any other suitable fasteners which are well known in the furniture-manufacturing industry.

5 In a particular example, the articulating joints (e.g., rotatable and pivotable couplings) are incorporated within the linkage mechanism 100 (e.g., rivets), with the possible exception of the rotational interface between the activator shaft 350 and the activator mounting plate 360. This feature of providing the articulating joints within the linkage mechanism 100 minimizes repair costs associated with wear, as the more expensive welded
10 assemblies (e.g., lift-base assembly 600) will not be exposed to wear. Although the rotational interface between the activator shaft 350 and the activator mounting plate 360 (including welded joints) is subject to wear, the assembly of the activator shaft 350, the activator mounting plate 360, and other fixedly attached components is easily replaced without disassembling any other portions of the linkage mechanism 100 or lift-base assembly 600.
15 Generally, in nonmoving connections (e.g., connection point 743 of FIG. 4), most other fasteners are standard bolts.

Also, the shapes of the linkages and the brackets may vary as desired, as may the locations of certain pivot points. It will be understood that when a linkage is referred to as being pivotably "coupled" to, "interconnected" with, "attached" on, etc., another element
20 (e.g., linkage, bracket, frame, and the like), it is contemplated that the linkage and elements may be in direct contact with each other, or other elements (such as intervening elements) may also be present.

Generally, the linkage mechanism 100 guides the rotational movement of the backrest, the minimal (if any) translation of the seat, and the extension of the ottoman(s). In
25 an exemplary configuration, these movements are controlled by a pair of essentially mirror-image linkage mechanisms (one of which is shown herein and indicated by reference numeral 100), which comprise an arrangement of pivotably interconnected linkages. The linkage mechanisms are typically disposed in opposing-facing relation about a longitudinally-extending plane that bisects the seating unit between the pair of opposed arms. As such, the
30 ensuing discussion will focus on only one of the linkage mechanisms 100, with the content being equally applied to the other, complimentary, linkage assembly.

With continued reference to FIG. 5, the lift-base assembly 600 will now be discussed. Typically, the lift-base assembly 600 serves as a foundation that rests on a surface

underlying the seating unit. The lift-base assembly 600 includes a front lateral member 610, a rear lateral member 620, a right longitudinal member 630, and a left longitudinal member (not shown). These members 610, 620, 630 may be formed from square metal tubing, or any other material used in the furniture-manufacturing industry that exhibits rigid properties. The front lateral member 610 and the rear lateral member 620 serve as crossbeams that span between and couple together the right longitudinal member 630 and the left longitudinal member. Generally, the rear lateral member 620 is oriented in substantially parallel-spaced relation to the front lateral member 610. Also, the right longitudinal member 630 is oriented in substantially parallel-spaced relation to the left longitudinal member, where the left and right longitudinal members 630 span and couple the front and rear lateral members 610 and 620. Further, the front lateral member 610 and the rear lateral member 620 are fixedly attached (e.g., welded or fastened at connection points 744 and 745) to a pair of lift brackets 740 (see FIG. 10), respectively, within the lift assemblies 700. As such, the lift-base assembly 600 extends between and fixedly attaches the lift assemblies 700 in a parallel-spaced manner.

When constructed into the lift-base assembly 600, the members 610 and 620 reside in substantial perpendicular relation with the right longitudinal member 630 and opposed left longitudinal member. In its role as a foundation, the lift-base assembly 600 acts as a platform by which the lift assembly 700 may raise and tilt the seating unit with respect to the underlying surface. Further, as more fully discussed below, the linear actuator of the motor assembly 300 controls movement of the lift assembly 700 and is pivotably coupled to the rear lateral member 620 of the lift-base assembly 600. Even further, the left and right longitudinal members 630 and the front and rear lateral members 610 and 620 represent a perimeter or profile of a footprint of the lift-base assembly 600. During adjustment of linkage mechanism 100, the seat is consistently maintained directly over the footprint of the lift-base assembly 600, thereby reaping those benefits (e.g., enabling complete fabric coverage of the lift assembly 700 and enhancing balance of the weight of an occupant within the seating unit) more fully discussed above. In other words, the linear actuator—providing automated adjustment of the seating unit between the closed position, the extended position, the reclined position, and the seat-lift position—is configured to move the lift assembly 700 into and out of the seat-lift position while maintaining the linkage mechanisms 100 in the closed position and while consistently maintaining the seat-mounting plates 400 inside a footprint of the lift-base assembly 600.

Referring to FIGS. 5 and 10, an automated version of the seating unit, which utilizes a single-motor linear actuator, is illustrated and will now be discussed via the embodiments below. In an exemplary embodiment, the linkage mechanism 100 and the lift-base assembly 600 (discussed immediately above) are coupled to the linear actuator of the motor assembly 300, which provides powered adjustment of the linkage mechanism 100 between the reclined, the extended, and the closed positions. Further, the linear actuator is employed to provide powered adjustment of the lift assemblies 700 into and out of the seat-lift position, while holding the linkage mechanism in the closed position. The motor assembly 300 includes a rear motor bracket 315, a motor mechanism 320, a front motor bracket 325, a track 330, a motor activator block 340, an activator shaft 350, and an activator mounting plate 360. Typically, the motor mechanism 320 and the motor activator block 340 are slidably connected to each other via the track 330, while the motor mechanism 320 and the motor activator block 340 are held in position by and pivotably coupled to the rear lateral member 620 of the lift-base assembly 600 and the base plate 410 of the linkage mechanism 100, respectively. For example, as illustrated in FIG. 5, the motor activator block 340 may be pivotably coupled to a section between a pair of ends of the rear lateral member 620 via the rear motor bracket 315.

This "linear actuator" is comprised of the motor mechanism 320, the track 330, and the motor activator block 340 and is coupled between the linkage mechanism 100 and the lift-base assembly 600. The motor mechanism 320 is protected by a housing that is pivotably coupled to the rear lateral member 620 of the lift-base assembly 600 via the rear motor bracket 315. The motor activator block 340 is pivotably coupled to the front motor bracket 325 by way of rotational components (e.g., bearings). The front motor bracket 325 is fixedly attached to a mid section of the activator shaft 350. The activator shaft 350 spans between and couples to the linkage mechanism 100 and the opposed, counterpart, mirror-image linkage mechanism (not shown). Also, the activator shaft 350 includes a pair of ends, where each of the ends of the activator shaft 350 is rotatably coupled to a respective base plate via a rotatable interface at an activator mounting plate. For instance, one of the ends of the activator shaft 350 may rotatably couple with the base plate 410 via a rotatable interface at the activator mounting plate 360, where the rotatable interface may comprise at least one of bearings, interlocking bushings, or any other device known in the furniture-fabrication industry that enables one component to pivot with respect to another component.

As discussed above, the activator shaft 350 spans between and couples together the linkage mechanism 100 shown in FIG. 5 and its counterpart, mirror-image linkage mechanism (not shown). In embodiments, the activator shaft 350 functions as a crossbeam and may be fabricated from metal stock (e.g., formed sheet metal). Similarly, a seat-mounting plate 400, a base plate 410, and a plurality of other links that comprise the linkage mechanism 100 may be formed from metal stock, such as stamped, formed steel. However, it should be understood and appreciated that any suitable rigid or sturdy material known in the furniture-manufacturing industry may be used in place of the materials described above.

Along these lines, in an exemplary embodiment, the base plates 410 may be fabricated from a straight tube with plate-type brackets (front base plate 415 and rear base plate 416) fixedly attached (e.g., welded or fastened) on each end. As illustrated in FIGS. 5 and 6, the front base plate 415 is fixedly attached to a forward portion 411 of the base plate 410 while the rear base plate 416 is fixedly attached to a rearward portion 412 of the base plate 410. In particular instances, the straight tube is constructed with a generally rectangular or square cross-section. Using a straight-tube design for the majority of the base plate 410, as opposed to a flat-plate configuration, helps minimize material and weight of the base plate 410 while, at the same time, increases torsional strength along the length of the base plate 410. Further, the straight-tube design provides a simple and strong attachment means (e.g., flat weld surface or parallel walls for receiving fasteners) for receiving the activator mounting plate 360 and for mating to the rear cross tube 690, which spans and couples the pair of substantially parallel-spaced base plates. In one example, self-tapping bolts may be installed to the straight tube in a substantially vertical direction to attach the activator mounting plate 360 and the rear cross tube 690 to the base plate 410, thereby enhancing ease of assembly, improving consistency in the assembly positions when coupling components of the linkage mechanism 100, and for imposing minimal shearing stress on the self-tapping bolts.

In operation, the motor activator block 340 travels toward or away from the motor mechanism 320 along the track 330 during automated adjustment of the linear actuator. In a particular embodiment, the motor mechanism 320 causes the motor activator block 340 to longitudinally traverse, or slide, along the track 330 under automated control. This sliding action produces a rotational and/or lateral force on the front motor bracket 325, which, in turn, generates movement of the linkage mechanism 100 via the activator shaft 350. As more fully discussed below, the sliding action is sequenced into a first phase, a second phase, and a

third phase. In an exemplary embodiment, the first phase, the second phase, and the third phase are mutually exclusive in stroke. In other words, the linear-actuator stroke of the first phase fully completes before the linear-actuator stroke of the second phase commences, and vice versa. Likewise, the linear-actuator stroke of the second phase fully completes before
5 the linear-actuator stroke of the third phase commences, and vice versa.

Initially, the track 330 is operably coupled to the motor mechanism 320 and includes a first travel section 331, a second travel section 332, and a third travel section 333. The motor activator block 340 translates longitudinally along the track 330 under automated control of the motor mechanism 320 such that the motor activator block 340 translates within
10 the first travel section 331 during the first phase, the second travel section 332 during the second phase, and the third travel section 333 during the third phase. As illustrated in FIG. 5, the dashed lines separating the first travel section 331, the second travel section 332, and the third travel section 333 indicate that the travel sections 331, 332, and 333 abut, however, they do not overlap. It should be realized that the precise lengths of the travel sections 331, 332,
15 and 333 are provided for demonstrative purposes only, and that the length of the travel sections 331, 332, and 333, or ratio of the linear-actuator stroke allocated to each of the first phase, second phase, and third phase, may vary from the length or ratio depicted.

Generally, the first phase involves longitudinal translation of the motor activator block 340 along the first travel section 331 of the track 330, which generates a first
20 rotational movement (over a first angular range) of the activator shaft 350 with respect to the activator mounting plate 360. The rotational interface at the activator mounting plate 360 converts the rotation movement to a lateral thrust that invokes first-phase movement. This first-phase movement controls adjustment of the seat-adjustment assembly 500 between the reclined position (see FIG. 9) and the extended position (see FIG. 8). Further, during the first
25 phase, the motor activator block 340 moves forward and upward with respect to the lift-base assembly 600, while the motor mechanism 320 remains generally fixed in space.

Once the stroke of the first phase is substantially complete, the second phase may occur. Generally, the second phase involves continued longitudinal translation of the motor activator block 340, but along the second travel section 332 of the track 330. This
30 translation within the second travel section 332 generates a second rotational movement (over a second angular range adjoining the first angular range) of the activator shaft 350 with respect to the activator mounting plate 360 at the front motor bracket 325, thereby invoking second-phase movement of the linkage mechanism 100. The second-phase movement

controls adjustment of (extends or retracts) the footrest assembly 200 between the extended position (see FIG. 8) and the closed position (see FIG. 7). Typically, during the stroke of the linear actuator within the second phase, the motor activator block 340 again moves forward and upward with respect to the lift-base assembly 600 while the motor mechanism 320
5 remains generally fixed in space.

In an exemplary embodiment, the first phase of movement includes the first range of degrees of angular rotation of the activator shaft 350 that does not intersect the second range of degrees included within the second phase of movement. Further, the first and second phase may be sequenced into specific movements of the linkage mechanism 100.
10 In embodiments, a weight of an occupant seated in the seating unit and/or springs interconnecting links of the seat-adjustment assembly 500 may assist in creating the sequence. Accordingly, the sequence ensures that adjustment of the footrest assembly 200 between the closed and extended positions is not interrupted by an adjustment of the backrest (attached to the back-mounting link 510), and vice versa. In other embodiments, as depicted
15 in FIGS. 7-9, a sequencing assembly integrated within the linkage mechanism 100 is provided to control the sequenced adjustment of the seating unit, thereby segregating those linkage articulations assigned to the first phase of movement from the linkage articulations assigned to the second phase of movement.

Once a stroke of the second phase is substantially complete, the third phase
20 occurs. During the third phase, the motor activator block 340 longitudinally translates forward and upward along the third travel section 333 of the track 330 with respect to the motor mechanism 320, while the motor mechanism 320 remains generally fixed in space. This longitudinal translation of the motor activator block 340 along the third travel section 333 creates a lateral thrust at the footrest drive bracket 580 but does not rotate the footrest
25 drive bracket 580 because one or more links of the linkage mechanism 100 has encountered one or more stop elements attached thereto (e.g., footrest drive bracket 580 has contacted an upper surface of the base plate 410), thus, securing the linkage mechanism 100 in a detent condition.

In one example of encountering a stop element, the angular rotation of the
30 second range (during the second-phase movement) is completed upon a leading rear edge of a footrest drive bracket 580 contacting an upper surface of the straight tube comprising the base plate 410. At this point, additional rotation of the activator shaft 350 is limited by the impeded rotation of the footrest drive bracket 580.

Consequently, the longitudinal translation along the third travel section 333 of the track 330 generates a forward and upward lateral thrust at the activator shaft 350, which invokes adjustment of the lift assemblies 700 into or out of the seat-lift position (see FIG. 10) while maintaining the pair of linkage mechanisms 100 in the closed position. That is, the stroke of the third phase raises and tilts forward the linkage mechanism 100, with respect to the lift-base assembly 600, thus, adjusting the lift assembly 700 between a collapsed configuration and an expanded seat-lift position that facilitates entry and egress to the seating unit. As mentioned above, the raise and forward tilt of the linkage mechanism 100 during the third-phase movement does not translate fore or aft the seat with respect to the lift-base assembly 600, thus, maintaining the seat directly over a perimeter or profile formed by the members 610, 620, and 630 of the lift-base assembly 600 on the underlying surface.

In one instance, the combination of the motor mechanism 320, the track 330, and the motor activator block 340 is embodied as an electrically powered linear actuator. In this instance, the linear actuator is controlled by a hand-operated controller that provides instructions to the linear actuator. These instructions may be provided upon detecting a user-initiated actuation of the hand-operated controller. Further, these instructions may cause the linear actuator to carry out a complete first phase and/or second phase of movement. Or, the instructions may cause the linear actuator to partially complete the first phase or the second phase of movement. As such, the linear actuator may be capable of being moved to and maintained at various positions within a stroke of the first phase or the second phase, in an independent manner.

Although a particular configuration of the combination of the motor mechanism 320, the track 330, and the motor activator block 340 has been described, it should be understood and appreciated that other types of suitable devices that provide sequenced adjustment may be used, and that embodiments of the present invention are not limited to a linear actuator as described herein. For instance, the combination of the motor mechanism 320, the track 330, and the motor activator block 340 may be embodied as a telescoping apparatus that extends and retracts in a sequenced manner.

Advantageously, the single-motor lift mechanism (i.e., innovative interaction of the single linear actuator within the motor assembly 300 and the linkage mechanism 100) in embodiments of the present invention allows for a seating-unit manufacturer to employ various styling features to the linkage mechanism 100 (e.g., T-cushion style seat) that are not possible in a push-on-the-arm style mechanism utilized by conventional lifter recliners.

Further, the single-motor lift mechanism provides the benefits of reduced wall clearance. Yet, as discussed more fully below, the total cost for fabricating the linkages, assembling the linkages, and shipping the assemblies of the single-motor lift mechanism is competitive or below conventional lifter recliners.

5 Turning to FIGS. 7-10, the components of the linkage mechanism 100 will now be discussed in detail. As discussed above, the linkage mechanism 100, which is raised and lowered by the lift assembly 700 (discussed below), includes the footrest assembly 200, the seat-mounting plate 400, the base plate 410, and the seat-adjustment assembly 500. The footrest assembly 200 includes a front ottoman link 110, a rear ottoman link 120, lower
10 ottoman link 130, an upper ottoman link 140, and a footrest bracket 170. The front ottoman link 110 is rotatably coupled to a forward portion 401 of the seat-mounting plate 400 at pivot 115. The front ottoman link 110 is also pivotably coupled to the upper ottoman link 140 at pivot 113 and the lower ottoman link 130 at pivot 117. Further, the front ottoman link 110 may include a front stop element (not shown) fixedly attached at a mid section thereof that
15 functions to resist continued extension of the footrest assembly 200 when the front stop element contacts a side of the upper ottoman link 140.

Referring to FIG. 5, the front ottoman link 110 is also pivotably coupled to a front end 591 of a footrest drive link 590 of the seat-adjustment assembly 500 at pivot 593. The footrest drive link 590 includes the front end 591 and a back end 592. The back end 592
20 of the footrest drive link 590 is pivotably coupled to a footrest drive bracket 580 at pivot 594. The footrest drive bracket 580 is fixedly attached to one of the ends of the activator shaft 350.

In operation, during adjustment of the seating unit between the closed position and the extended position, the linear actuator causes the activator shaft 350 to rotate upon translating the motor activator block 340 over the second travel section 332 of the track 330.
25 The rotation of the activator shaft 350 rotates the footrest drive bracket 580 forward (e.g., counterclockwise with respect to FIG. 5). This rotation of the footrest drive bracket 580 generates a forward lateral thrust of the footrest drive link 590, via the interaction at the pivot 594, that acts on the pivot 573 of the front ottoman link 110. The forward lateral thrust acting on the pivot 573 pushes outward on the front ottoman link 110 causing the front ottoman link
30 110 to rotate at the pivot 115 in a direction away from the seat-mounting plate 400 (e.g., clockwise with respect to FIG. 5) and, consequently, extend the footrest assembly 200.

Returning to the footrest assembly 200, in embodiments, the rear ottoman link 120 is rotatably coupled to the forward portion 401 of the seat-mounting plate 400 at pivot

121 and is pivotably coupled to the upper ottoman link 140 at pivot 133. In embodiments, the pivot 121 of the rear ottoman link 120 is slightly rearward of the pivot 115 of the front ottoman link 110. Further, as shown in FIG. 9, the rear ottoman link 120 is pivotably coupled to a front end 541 of a cam control link 540 of the seat-adjustment assembly 500 at pivot 275.

5 Interaction between the cam control link 540 and a sequence cam 550 enables mutually exclusive sequencing between the first phase and second phase. For example, during adjustment in the second phase (i.e., adjustment between the closed and extended positions), a moment of rotation transferred by the linear actuator to the footrest drive bracket 580, via the activator shaft 350, causes the footrest drive link 590 to exert a directional force on the

10 front ottoman link 110 that either extends the footrest assembly 200 to the extended position or collapses the footrest assembly 200 to the closed position. During the second phase of movement, as illustrated in FIGS. 7 and 8, the extension of the footrest assembly 200 pulls forward and upward on the cam control link 540 via the pivot 275. This forward and upward pulling action creates a directional force at pivot 552, which pivotably couples a rear end 542

15 of the cam control link 540 to the sequence cam 550. This direction force causes the sequence cam 550 to rotate (e.g., clockwise with respect to FIGS. 7 and 8) about pivot 551, which rotatably couples the sequence cam 550 to a mid section of the seat-mounting plate 400. This rotation about the pivot 551 biases the sequence cam 550 upward (see FIG. 8), such that a contact edge 554 of a forward portion 553 of the sequence cam 550 is not in

20 contact and/or physical proximity with a sequence element 420, or biases the sequence cam 550 downward (see FIG. 7), such that the contact edge 554 is in contact and/or physical proximity with the sequence element 420 extending from a connector link 450.

Further, with reference to the footrest assembly 200 at FIG. 9, the upper ottoman link 140 is pivotably coupled on one end to the rear ottoman link 120 at the pivot

25 133 and the front ottoman link 110 at the pivot 113. At an opposite end, the upper ottoman link 140 is pivotably coupled to the footrest bracket 170 at pivot 172. The lower ottoman link 130 is further pivotably coupled to the front ottoman link 110 at the pivot 117 and to the footrest bracket 170 at pivot 175. In embodiments, the footrest bracket 170 is designed to attach to ottoman(s), such as the foot-support ottoman 45, respectively. In a specific instance,

30 as shown in FIG. 2, the footrest bracket 170 supports ottoman(s) in a substantially horizontal disposition when the footrest assembly 200 is fully extended upon completion of the second phase of movement.

A spring-loaded ottoman bracket 180 may be provided as an option in some models of the seating unit. As illustrated in FIG. 8, the footrest bracket 170 is replaced by the spring-loaded ottoman bracket 180 which includes a safety footrest bracket 150, a safety footrest mounting link 160, and a safety footrest pivot link 190, and a tension element 195 (e.g., spring link). The safety footrest mounting link 160 includes one end that is proximal to the footrest assembly 200 and another end that is distal to and extends outwardly from the footrest assembly 200. The proximal end of the safety footrest mounting link 160 is pivotably coupled to an upper end of the upper ottoman link 140 at the pivot 172 and is pivotably coupled to an upper end of the lower ottoman link 140 at the pivot 175, where the pivot 172 is located inward on the safety footrest mounting link 160 with respect to the pivot 175. The distal end of the safety footrest mounting link 160 is pivotably coupled to a lower end of the safety footrest pivot link 190 at pivot 123.

In embodiments, as illustrated in FIG. 8, a portion of the safety footrest pivot link 190 extends downwardly beyond the pivot 123 and includes a mounting location (e.g., aperture 118) for securing a first end of the tension element 195, while the balance of the safety footrest pivot link 190 extends upwardly above the pivot 123. An upper end of the safety footrest pivot link 190 is typically coupled to a rearward portion of the safety footrest bracket 150 at pivot 126. A mid portion of the safety footrest bracket 150 includes a mounting location for securing a second end of the tension element 195 that is opposed to the first end of the tension element that is secured to the aperture 118. In operation, the tension element 195 resides in tension between the respective mounting locations, where the tension exerts a linear force that urges the safety footrest bracket 152 remain in a generally parallel-spaced relationship with the safety footrest mounting link 160.

The safety footrest bracket 150 is configured for fixedly holding an ottoman, such as the foot-support ottoman 45 of FIG. 2. When the spring-loaded ottoman bracket 180 is extended along with the footrest assembly 200, the safety footrest bracket 150 holds the ottoman upward from the footrest assembly 200 in a substantially horizontal orientation, thereby providing heightened support for the legs of an occupant of the seating unit. When the spring-loaded ottoman bracket 180 is collapsed along with the footrest assembly 200, the safety footrest bracket 150 holds the ottoman against the footrest assembly 200 in a substantially vertical orientation such that the ottoman can serve as a front panel of the seating unit.

In embodiments, the safety footrest mounting link 160 includes a pin 119 (e.g., welded bushing or fastener) that is attached to and projects transversely from therefrom. The safety footrest pivot link 190 may include an arcuate slot 125 formed therein. The arcuate slot 125 may include an arc-shaped curvature that follows a consistent radius from the pivot
5 123. Also, the arcuate slot 125 maybe located on the lower end of the safety footrest pivot link 190 proximate to the pivot 123. Further, the arcuate slot 125 may receive a portion of the pin 119. In operation, physical contact between a first end of the arc-shaped curvature of the arcuate slot 125 and the pin 119 prevents additional counterclockwise rotation of the safety footrest pivot link 190 with respect to the footrest assembly 200 and further extension
10 of the tension element 195. As the safety footrest pivot link 190 rotates clockwise with respect to the footrest assembly 200, the pin 119 travels within the arcuate slot 125 until meeting a second end of the arc-shaped curvature. Physical contact between the pin 119 in the second end of the arc-shaped curvature assists in resisting collapse of the spring-loaded ottoman bracket 180.

15 Turning to FIGS. 8 and 9, the seat-adjustment assembly 500, which reclines and inclines the backrest, will now be discussed. In embodiments, the seat-adjustment assembly 500 includes a front pivot link 430, a front lift link 440, a connector link 450, a rear lift link 460, a back-mounting link 510, a back-support link 520, the cam control link 540, the sequence cam 550, the footrest drive bracket 580, and the footrest drive link 590. Initially,
20 the back-mounting link 510 rotatably coupled to a rearward portion 402 of the seat-mounting plate 400 at pivot 405. In instances, the back-mounting link 510 may be configured to support a backrest of the seating unit. The back-support link 520 includes an upper end 523 and a lower end 524. The upper end 523 of the back-support link 520 is pivotably coupled to the back-mounting link 510 at pivot 511 while the lower end 524 of the back-support link 520
25 is pivotably coupled to the rear base plate 416 or a rearward portion 412 of the base plate 410 at pivot 521.

The rear lift link 460 is rotatably coupled to the seat-mounting plate 400 at pivot 462 and is pivotably coupled to the rear base plate 416 or the rearward portion 412 of the base plate 410 at pivot 461. Also, the rear lift link 460 is pivotably coupled to the
30 connector link 450 at pivot 463. The connector link 450 that includes a front end 451 and a rear end 452. The rear end 452 of the connector link 450 is pivotably coupled with the rear lift link 460 at the pivot 463. The front end 451 of the connector link 450 is pivotably coupled with the front lift link 440 at a pivot 443.

As illustrated in FIGS. 5 and 9, the front lift link 440 is rotatably coupled to the forward portion 401 of the seat-mounting plate 400 at pivot 442. Further, the front lift link 440 is pivotably coupled to the front end 451 of the connector link 450 at the pivot 443 while the front pivot link 430 is pivotably coupled to the front lift link 440 at pivot 441. The front pivot link 430 includes an upper end 432 and a lower end 431. The upper end 432 of the front pivot link 430 is pivotably coupled to the front lift link 440 at the pivot 441, while the lower end 431 of the front pivot link 430 is pivotably coupled to the front base plate 415 or the forward portion 411 of the base plate 410 at pivot 433. That is, as discussed above, the base plate 410 may be formed of a single member (e.g., square straight tube) or may be composed of a plurality of formed plates.

As mentioned above, with respect the second phase of movement, the footrest drive bracket 580 and the footrest drive link 590 interact to propel the footrest assembly 200 forward, via a directional force on the pivot 573 of front ottoman link 110, or to retract the footrest assembly 200 rearward. The footrest drive bracket 580 is fixedly attached to one of the ends of the activator shaft 350. As illustrated in FIG. 5, the footrest drive bracket 580 is fixedly attached to the right end of the activator shaft 350 in a location outward of the rotational interface at the activator mounting plate 360. However, the precise location of the fixed attachment of the footrest drive bracket 580 to the activator shaft 350 may vary. For instance, embodiments of the present invention consider a location of the fixed attachment of the footrest drive bracket 580 to be inward of the rotation interface at the activator mounting plate 360.

Typically, the footrest drive link 590 includes the front end 591 and the back end 592. The back end 592 of the footrest drive link 590 is pivotably coupled to an arm of the footrest drive bracket 580 extending radially from the activator shaft 350 at the pivot 594. The front end 591 of the footrest drive link 590 is pivotably coupled to the front ottoman link 110 of the footrest assembly 200 at the pivot 573. In operation, the linear actuator's angular rotation of the activator shaft 350 directly affects the extended or collapsed configuration of the footrest assembly via the interaction of the footrest drive link 590 and the footrest drive bracket 580.

Turning now to FIGS. 7 and 8, the cam control link 540, the sequence cam 550, and the sequence element 420 will now be discussed. The cam control link 540 includes a front end 541 and a rear end 542. The front end 541 of the cam control link 540 is pivotably coupled with the rear ottoman link 120 of the footrest assembly 200 at the pivot

275. In embodiments, the pivot 275 is slightly below and proximate to the pivot 121, which rotatably couples the rear ottoman link 120 to the forward portion 401 of the seat-mounting plate 400. The rear end 542 of the cam control link 540 is pivotably coupled with the sequence cam 550 at the pivot 552. The sequence cam 550 is rotatably coupled to the seat-mounting plate 400 at the pivot 551. In particular, the pivot 551 is located in a mid section of the sequence cam 550, while a contact edge 554 is located on segment of an exterior surface of a forward portion 553 of the sequence cam 550.

In embodiments, the sequence element 420 is configured as a welded bushing, a grommet, a cylindrically shaped element, a fastener (e.g., bolt or rivet), or any other any other rigid component that effortlessly ride or travel along a face of the contact edge 554. Generally, the sequence element 420 is fixedly attached to a mid section of the connector link 450. In one instance, the sequence element 420 extends at a substantially perpendicular, inward direction from an interior side of the connector link 450. In operation, during first-phase of movement of the seating unit, the contact edge 554 of the sequence cam 550 is removed from being adjacent to the sequence element 420, thereby allowing the seat-adjustment assembly 500 to recline the back-mounting link 510 and, in turn, the backrest.

During second-phase of movement, the contact edge 554 of the sequence cam 550 is rotated about the pivot 551 (e.g., counterclockwise with respect to FIGS. 7 and 8) to reside adjacent to the sequence element 420. That is, adjustment of the footrest assembly 200 between the closed position (see FIG. 7) and extended position (see FIG. 8) may, in turn, articulably actuate the cam control link 540 laterally. This lateral actuation resulting from collapsing the footrest assembly 200 (i.e., rotating the rear ottoman link 120 inward about the pivot 121) causes the sequence cam 550 to rotate about the pivot 551 such that contact edge 554 moves downward to face and, potentially, engage the sequence element 420. Consequently, the rotation of the sequence cam 550 changes a relative position of the sequence element 420 with respect to the contact edge 554.

This obstruction formed by the contact edge 554 of the sequence cam 550 residing adjacent to the sequence element 420 impedes forward translational movement of the seat-mounting plate 400 (coupled directly to the sequence cam 550 at the pivot 551) with respect to the base plate 410 (coupled to the sequence element 420 via the rear lift link 460 and the connector link 450). Impeding translational movement of the seat-mounting plate 400 with respect to the base plate 410, in effect, physically prevents the seat-adjustment assembly 500 from reclining the back-mounting link 510 while, at the same time, allows the

footrest assembly 200 to extends or collapse the foot-support ottoman(s). That is, when the seating unit is adjusted to the closed position (see FIG. 7), the interaction between the sequence element 420 and the contact edge 554 of the sequence cam 550 prevents direct adjustment of the seating unit to the reclined position (see FIG. 9). However, when the contact edge 554 is adjacent to the sequence cam 550, the seating unit may be adjusted to the extended position (see FIG. 8).

Upon adjusting the seating unit to the expended position, the extension of the footrest assembly 200 causes the cam control link 540 to actuate forward in a lateral manner. This forward lateral actuation resulting from extending the footrest assembly 200 (i.e., rotating the rear ottoman link 120 outward about the pivot 121) causes the sequence cam 550 to rotate about the pivot 551 such that contact edge 554 moves upward to face away from the sequence element 420. Consequently, the rotation of the sequence cam 550 removes the impendence that formerly prevented the seat-mounting plate 400 from translating with respect to the base plate 410 and, thus, allows for second-phase movement of the seat-adjustment assembly 500.

Accordingly, the sequencing described above ensures that adjustment of the footrest assembly 200 between the closed and extended positions is not interrupted by rotational biasing of the backrest, or vice versa. In other embodiments, the weight of the occupant of the seating unit and/or springs interconnecting links of the seat-adjustment assembly 500 assist in creating or enhancing the sequencing.

With reference to FIGS. 6 and 10, the lift assembly 700 will now be discussed. The lift assembly 700 includes the riser connector plate 710, an upper lift link 720, a lower lift link 730, and the lift bracket 740. The lift assembly 700 is fixedly attached to a mirror-image lift assembly (not shown) via a front cross tube 680, where one end of the front cross tube 680 may be fixedly attached to the lower lift link 730 directly or via intervening hardware (e.g., bracket 681). As discussed more fully above, the rear cross tube 690 spans and couples the base plate 410 with a complimentary base plate on the mirror-image linkage mechanism (not shown). In embodiments, the front cross tube 680 and the rear cross tube 690 may be formed from square metal tubing and may function as a set of crossbeams that rigidly secure the right linkage mechanism 100 and the left mirror-image linkage mechanism in parallel-spaced relation.

In embodiments, the lift assembly 700 (shown) is fixedly attached to the right longitudinal member 640 of the lift-base assembly 600 via the lift bracket 740 at connection

points 744 and 745, while the mirror-image lift assembly (not shown) is fixedly attached to the left longitudinal member 630. Additionally, the riser connector plate 710 is fixedly attached to the lift bracket 740 via the connection point 743. As discussed more fully above, the connection point 743 allows for mounting the linkage mechanism 100 to the lift-base assembly 600 with only one fastener (e.g., shoulder bolt), thus, simplifying the assembly process of attaching the linkage mechanism 100 to the lift-base assembly 600 such that assembly may be easily performed subsequent to shipping on the premise of a seating-unit manufacturer.

Turning to FIG. 10, the internal connections of the lift assembly 700 will now be discussed. In embodiments, the riser connector plate 710 is fixedly attached to a respective longitudinal member of the lift-base assembly 600 via the lift bracket 740 at connection point 743. Also, the riser connector plate 710 includes an upper end 713 and a lower end 714. The upper lift link 720 is pivotably coupled at one end to the front base plate 415, or forward portion 411 of the base plate 410, at pivot 711. The upper lift link 720 is also rotatably coupled at another end to the upper end 713 of the riser connector plate 710 at pivot 741. The lower lift link 720 is pivotably coupled at one end to the front base plate 415, or forward portion 411 of the base plate 410, at pivot 712. In embodiments, the pivot 712 is forward of and proximate to the pivot 711. The lower lift link 720 is rotatably coupled at another end to the lower end 714 of the riser connector plate 710 at pivot 742.

In operation, the lift links 720 and 730 are configured to swing in a generally parallel-spaced relation when the linear actuator adjusts the seating unit into and out of the seat-lift position. Further, the configuration of the lift links 720 and 730 allow the base plate 410 to move in a path that is upward and tilted forward when adjusting to the seat-lift position of FIG. 10. As discussed above, movement into and out of the seat-lift position occurs in the third phase of the linear-actuator stroke in which the motor activator block 340 longitudinally traverses the track 330 within the third travel section 333.

Generally, the lift assembly 700 is designed such that there exists a relatively small amount of contact area between linkage mechanism 100 and the lift-base assembly 600. In particular embodiments, the entire contact area includes a forward region and a rearward region. The forward region is located along the front lateral member 610 where the front base plate 415 and/or an edge of the lower lift link 730 meets an upper surface of the front lateral member 610 when the seating unit is not adjusted to the seat-lift position. The rearward region is located at the top of the lift bracket 740, which is welded to the lift-base

assembly 600. The rearward region of the contact area is high above the a frame comprising the lift-base assembly 600, thereby greatly minimizing any potential for a rear pinch point as the seating unit lowers downward to the closed position. By removing positional for the rear pinch point, harm to fingers, pets, or power cables to the linear actuators are avoided.

5 The operation of the seat-adjustment assembly 500 will now be discussed with reference to FIGS. 8 and 9. Initially, an occupant of the seating unit may invoke an adjustment from the reclined position (FIG. 9) to the extended position (FIG. 8) in an effort to sit upright for viewing television. In an exemplary embodiment, the occupant may invoke an actuation at a hand-operated controller that sends a control signal with instructions to the
10 linear actuator. As discussed above, the linear actuator moves in a sequenced manner, which is enforced by a weight of the occupant, a placement of springs within the seat-adjustment assembly 500, and/or a configuration of the sequence cam 550 with respect to the sequence element 420. Typically, the movement of the linear actuator is sequenced into three substantially independent strokes: the first phase (adjusting between the reclined and
15 extended positions), the second phase (adjusting between the extended and closed positions), and the third phase (adjusting into and out of the seat-lift position (see FIG. 10) while the linkage mechanism 100 resides in the closed position).

 Upon receiving the control signal from the hand-operated controller when the linkage mechanism 100 resides in the reclined position, the linear actuator carries out a stroke
20 in the first phase. That is, with reference to FIG. 6, the linear actuator slides the motor activator block 340 forward with respect to the lift-base assembly 600 (over the first travel section 331), while holding the motor mechanism 320 relatively fixed in space. This sliding action of the motor activator block 340 invokes first-phase movement (angular rotation over a first range of degrees) at the footrest drive bracket 580 about the rotational interface with the
25 activator mounting plate 360. This first-phase movement of the footrest drive bracket 580 pulls the footrest drive link 590 rearward a particular distance, which causes the seat-mounting plate 400 to translate over the base plate 410 in a rearward manner (via the pivot 593). At this point, the seat-mounting plate 400 is allowed to translate rearward over the base plate 410 because the sequence cam 550 is removed from proximity with the sequence
30 element 420.

 As discussed above, the seat-mounting plate 400 is pivotably coupled to the rear lift link 460 at the pivot 462. The rearward traversal of the seat-mounting plate 400 acts through the pivot 462 causing counterclockwise rotation of the rear lift link 460 about the

pivot 461. This counterclockwise rotation moves the seat-mounting plate 400 downward and rearward with respect to the lift-base assembly 600. Movement of the seat-mounting plate 400 in this rearward direction pulls the back-mounting link 510, along with the backrest, downward at the pivot 405 and causes the back-mounting link 510 to rotate forward about the
5 pivot 511.

In addition, the counterclockwise rotation of the rear lift link 460 about the pivot 461, which is triggered by the rearward movement of the seat-mounting plate 400, pushes the connector link 450 forward with respect to the base plate 410. This forward push on the connector link 450 moves the sequence element 420 (attached to the connector link
10 450) in front of a swing path of the contact edge 554 of the sequence cam 550, thereby allowing the sequence cam 550 to rotate downward when adjusting the seating unit to the closed position. Further, the forward push on the connector link 450 applies a directional force to the pivot 443 of the front lift link 440, which transmits the directional force through the front lift link 440 onto the pivot 441 (coupling the front lift link 440 to the front pivot link
15 430). The direction force transmitted to the front pivot link 430 acts to lower the forward portion 401 of the seat-mounting plate 400 via clockwise rotation of the front lift link 440 at the pivot 442. In this way, this clockwise rotation of the front lift link 440 about the pivot 442 pulls the forward portion 401 of the seat-mounting plate 400 downward and rearward in tandem with the rearward portion 402 of the seat-mounting plate. As a result, the seat-
20 mounting plate 400 is evenly lowered and slightly translated rearward such that the seat carried by seat-mounting plate 400 remains in a consistent angle of inclination during adjustment between the reclined position and the closed position.

Eventually, the rotation of the activator shaft 350 and, consequently, the footrest drive bracket 580 is ceased upon the linear actuator reaching the end of the first
25 travel section 331. At this point, adjustment from the reclined position to the extended position is substantially complete. Adjustment from the extended position to the reclined position operates substantially similar, but in reverse, to the steps described above.

The operation of the footrest assembly 200 will now be discussed with reference to FIGS. 7 and 8. As discussed above, when desiring to move from the extended
30 position (FIG. 8) to the closed position (FIG. 7), the occupant may invoke an actuation at the hand-operated controller that sends the control signal with instructions to the linear actuator to carry out a stroke in the second phase. Upon receiving the control signal from the hand-operated controller, the linear actuator slides the motor activator block 340 forward and

upward with respect to the lift-base assembly 600 (over the second travel section 332) while holding the motor mechanism 320 relatively fixed in space. This sliding action of the motor activator block 340 rotates the footrest drive bracket 580 about the rotational interface with the activator mounting plate 360. This clockwise rotation of the footrest drive bracket 580
5 triggers second-phase movement (angular rotation over a second range of degrees) at the footrest drive bracket 580.

This second-phase movement of the footrest drive bracket 580 pulls the footrest drive link 590 rearward a particular distance, which attempts to cause the seat-mounting plate 400 to translate over the base plate 410 in a rearward manner (via the pivot
10 593). However, the seat-mounting plate 400 is blocked from translating rearward over the base plate 410 because the sequence cam 550 is moved into proximity with the sequence element 420 such that the contact edge 554 encounters the sequence element 420.

Yet, the second-phase movement (angular rotation over a second range of degrees) of the footrest drive bracket 580 serves to translate the footrest drive link 590
15 rearward, thereby generating a rearward directional force at the pivot 573. This rearward translation of the footrest drive link 590 pulls the front ottoman link 110 downward about the pivot 115 and rotates the rear ottoman link 120 downward about the pivot 121 via the upper ottoman link 140. The rear ottoman link's 120 downward rotation about the pivot 121 produces a downward and rearward force on the cam control link 540 via the pivot 275. This
20 downward and rearward force causes the cam control link 540 to shift rearward and downward through the pivot 552, thus, causing the sequence cam 550 to rotate counterclockwise about the pivot 551 (rotatably coupling the sequence cam 550 to the seat-mounting plate 400).

Further, the front ottoman link's 110 downward rotation about the pivot 115
25 produces a downward and rearward force on the lower ottoman link 130 and, indirectly, the other links 120, 140, and 170, which pulls them toward the lift-base assembly 600. In one instance, this downward and rearward force on the front ottoman link 110 removes the front ottoman link 110 from contact with a stop element that serves to limit the extension of the footrest assembly 200. As such, the foot-support ottomans are retracted to a position
30 substantially below a front edge of the seat.

Also, similar to the adjustment in the first phase, the second-phase movement of the linear actuator generates clockwise rotation of the footrest drive bracket 580. Eventually, the clockwise rotation of the footrest drive bracket 580 is resisted upon a side of

the footrest drive bracket 580 contacting a top surface of the base plate 410, as shown in FIG. 6. At this point, adjustment from the extended position to the closed position is substantially complete.

5 In a manner that is reverse to the steps discussed above, with reference to operation of the footrest assembly 200 from the closed position to the extended position, the automated force of the linear actuator upon the footrest drive bracket 580 in the first phase of the linear-actuator stroke forces the footrest drive link 590 forward, which, in turn, rotates the front ottoman link 110 about the pivot 115. This rotation acts to extend the footrest assembly 200 and causes the other links 120, 130, 140, and 170 to move upwardly and/or rotate in a
10 clockwise direction, with reference to FIG. 8. Also, the footrest bracket 170 is raised and rotated in a clockwise fashion such that the ottoman(s) 45 (see FIGS. 1-3) are adjusted from a collapsed, generally vertical orientation to an extended, generally horizontal orientation. Extension of the footrest assembly is restrained upon the front ottoman link 110 coming into contact with a stop element or another detention feature.

15 It should be understood that the construction of the linkage mechanism 100 lends itself to enable the various links and brackets to be easily assembled and disassembled from the remaining components of the seating unit. Specifically the nature of the pivots and/or mounting locations, allows for use of quick-disconnect hardware, such as a knock-down fastener. Accordingly, rapid disconnection of components prior to shipping, or rapid
20 connection in receipt, is facilitated.

The present invention has been described in relation to particular embodiments, which are intended in all respects to be illustrative rather than restrictive. Alternative embodiments will become apparent to those skilled in the art to which the present invention pertains without departing from its scope.

25 It will be seen from the foregoing that this invention is one well adapted to attain the ends and objects set forth above, and to attain other advantages, which are obvious and inherent in the device. It will be understood that certain features and subcombinations are of utility and may be employed without reference to other features and subcombinations. This is contemplated by and within the scope of the claims. It will be appreciated by persons
30 skilled in the art that the present invention is not limited to what has been particularly shown and described hereinabove. Rather, all matter herein set forth or shown in the accompanying drawings is to be interpreted as illustrative and not limiting.

CLAIMS

What is claimed is:

1. A seating unit having a chassis, a seat, a backrest, and at least one foot-support ottoman, the seating unit being adapted to move between a closed, an extended, a reclined, and a seat-lift position, the seating unit comprising: a lift-base assembly that rests on
5 an underlying surface; a pair of base plates in substantially parallel-spaced relation; a pair of lift assemblies, wherein each of the lift assemblies is attached to a respective base plate and raises and lowers the respective base plate directly above the lift-base assembly; a pair of
10 seat-mounting plates in substantially parallel-spaced relation, wherein the seat-mounting plates suspend the seat over the lift assemblies; a pair of generally mirror-image linkage mechanisms each moveably interconnecting each of the base plates to a respective seat-mounting plate, wherein each of the linkage mechanisms comprise: (a) a footrest assembly that extends and retracts the at least one foot-support ottoman; and (b) a seat-adjustment assembly that reclines and inclines the backrest; and a linear actuator that provides automated
15 adjustment of the seating unit between the closed position, the extended position, the reclined position, and the seat-lift position, wherein the linear actuator is configured to move the lift assemblies into and out of the seat-lift position while maintaining the linkage mechanisms in the closed position and while consistently maintaining the seat-mounting plates inside a footprint of the lift-base assembly.

20 2. The seating unit of claim 1, wherein the linear actuator comprises: a motor mechanism; a track operably coupled to the motor mechanism, wherein the track includes a first travel section, a second travel section, and a third travel section; and a motor activator block that translates longitudinally along the track under automated control.

3. The seating unit of claim 2, wherein the linear-actuator adjustment is sequenced into a first phase, a second phase, and a third phase that are mutually exclusive in stroke, wherein the first phase moves the seat-adjustment as ssembly between the reclined position and the extended position when the motor activator block is translated over the first travel section of the track, wherein the second phase moves the footrest assembly between the extended position and the closed position when the motor activator block is translated over the second travel section of the track; and wherein the third phase moves the lift assemblies into and out of the seat-lift position when the motor activator block is translated over the third travel section of the track.

4. The seating unit of claim 3, further comprising an activator shaft that spans between and couples to the linkage mechanisms, wherein the activator shaft having a pair of ends, wherein one of the ends of the activator shaft is rotatably coupled to a respective base plate via an activator mounting plate.

5. The seating unit of claim 4, wherein the seat-adjustment assembly comprises: a footrest drive bracket that is fixedly attached to one of the ends of the activator shaft; and a footrest drive link that includes a front end and a back end, wherein the footrest drive bracket is pivotably coupled to the back end of the footrest drive link and the front end of the footrest drive link is pivotably coupled to the footrest assembly.

6. The seating unit of claim 5, wherein the footrest assembly comprises a front ottoman link that is rotatably coupled to a forward portion of a respective seat-mounting plate, and wherein the front end of the footrest drive link is pivotably coupled to the front ottoman link.

7. The seating unit of claim 6, wherein adjusting the seating unit between the closed position and the extended position involves causing the activator shaft to rotate upon translating the motor activator block over the second travel section of the track, wherein the rotation of the activator shaft generates a forward or rearward thrust at the front ottoman link via the interaction of the footrest drive link and the footrest drive bracket.

8. The seating unit of claim 7, wherein the lift-base assembly comprises: a front lateral member; a rear lateral member that is oriented in substantially parallel-spaced relation to the front lateral member; a left longitudinal member; and a right longitudinal member that is oriented in substantially parallel-spaced relation to the left longitudinal member, wherein the left and right longitudinal members span and couple the front and rear lateral members, and wherein the left and right longitudinal members and the front and rear lateral members represent a perimeter of the footprint of the lift-base assembly.

9. The seating unit of claim 8, wherein the motor activator block is pivotably coupled to a section between a pair of ends of the rear lateral member via a rear motor bracket, and wherein, during the stroke of the linear actuator within the first phase, the motor activator block moves forward and upward with respect to the lift-base assembly while the motor mechanism remains generally fixed in space.

10. The seating unit of claim 9, wherein the first phase involves longitudinal translation of the motor activator block along the first travel section that creates a moment of rotation about the activator shaft via one or more front motor brackets, wherein the one or more front motor brackets are pivotably coupled to the motor activator block and fixedly attached to the activator shaft.

11. The seating unit of claim 10, wherein the third phase involves longitudinal translation of the motor activator block along the third travel section that creates a lateral thrust at the activator bar, thereby invoking adjustment of the lift assemblies into or out of the seat-lift position while maintaining the pair of linkage mechanisms in the closed position.

12. The seating unit of claim 11, wherein, during the stroke of the linear actuator within the third phase, when adjusting the lift assemblies into the seat-lift position, the motor activator block moves forward and upward with respect to the lift-base assembly while the motor mechanism remains generally fixed in space.

13. The seating unit of claim 12, wherein each of the lift assemblies comprise: a riser connector plate that is fixedly attached to a respective longitudinal member of the lift-base assembly, the riser connector plate having an upper end and a lower end; an upper lift link that is pivotably coupled at one end to a respective base plate and is rotatably
5 coupled at another end to the upper end of the riser connector plate; and a lower lift link that is pivotably coupled at one end to a respective base plate and is rotatably coupled at another end to the lower end of the riser connector plate.

14. A pair of the generally mirror-image linkage mechanisms adapted to move a seating unit between a reclined, an extended, a closed, and a seat-lift position, the seating unit having a pair of lift assemblies that are adapted to adjust the seating unit into and out of the seat-lift position, a seat that is angularly biased via the lift assemblies, and a
5 backrest that is angularly adjustable with respect to the seat, each of the linkage mechanisms comprising: a seat-mounting plate that includes a forward portion, a mid portion, and a rearward portion, wherein the seat is fixedly mounted to the seat-mounting plate; a seat-adjustment assembly that reclines and inclines the backrest; a footrest assembly that extends and retracts at least one foot-support ottoman; a cam control link that includes a front end and
10 a rear end, wherein the front end of the cam control link is pivotably coupled with the footrest assembly; a sequence cam that includes a contact edge and is rotatably coupled to the seat-mounting plate, wherein the rear end of the cam control link is pivotably coupled to the sequence cam; a linear actuator that provides automated adjustment of the seating unit between the closed position, the extended position, the reclined position, and the seat-lift
15 position, wherein the linear-actuator adjustment is sequenced into a first phase, a second phase, and a third phase that are mutually exclusive in stroke, wherein the first phase moves the seat-adjustment assembly between the reclined position and the extended position, wherein the second phase moves the footrest assembly between the extended position and the closed position, and wherein the third phase moves the pair of lift assemblies into and out of
20 the seat-lift position while maintaining the pair of linkage mechanisms in the closed position; and a sequence element that extends outwardly from a respective linkage mechanism, wherein, during first-phase adjustment, the contact edge of the sequence cam is removed from the sequence element, thereby allowing the seat-adjustment assembly to recline the backrest, and wherein, during second-phase adjustment, the contact edge of the sequence cam
25 is adjacent to the sequence element, thereby physically preventing the seat-adjustment assembly from reclining the backrest while the footrest assembly extends the at least one foot-support ottoman.

15. The linkage mechanism of claim 14, further comprising: a base plate; and an activator shaft having a pair of ends, wherein one of the ends of the activator shaft is
30 rotatably coupled to the base plate.

16. The linkage mechanism of claim 15, wherein the seat-adjustment assembly comprises: a footrest drive bracket that is fixedly attached to one of the ends of the activator shaft; and a footrest drive link that includes a front end and a back end, wherein the footrest drive bracket is pivotably coupled to the back end of the footrest drive link and the
5 front end of the footrest drive link is pivotably coupled to the footrest assembly.

17. The linkage mechanism of claim 16, wherein the footrest assembly comprises: a front ottoman link that is rotatably coupled to the forward portion of the seat-mounting plate; and a rear ottoman link that is rotatably coupled to the forward portion of the seat-mounting plate at a location rearward of the front ottoman link.

10 18. The linkage mechanism of claim 17, wherein the front end of the footrest drive link is pivotably coupled to the front ottoman link, and wherein the front end of the cam control link is pivotably coupled to the rear ottoman link.

15 19. The linkage mechanism of claim 16, wherein first-phase adjustment of the linear actuator causes the footrest drive bracket to angularly bias within a first range of degrees via the activator shaft, wherein the second-phase adjustment of the linear actuator causes the footrest drive bracket to angularly bias within a second range of degrees that does not overlap a first range of degrees, wherein the angular bias within the first range of degrees generates movement of the seat-adjustment assembly while maintaining the at least one foot-support ottoman in an extended orientation, and wherein the angular bias within the second
20 range of degrees generates movement of the footrest assembly while maintaining the backrest in an inclined orientation.

20. A seating unit, comprising: a lift-base assembly that contacts an underlying surface; a pair of base plates in substantially parallel-spaced relation; a pair of lift assemblies, wherein each of the lift assemblies is attached to a respective base plate and moveably supports the respective base plate with respect to the lift-base assembly, wherein
5 the lift assemblies are adapted to adjust the seating unit into and out of a seat-lift position; a pair of seat-mounting plates in substantially parallel-spaced relation, wherein each of the seat-mounting plates is consistently disposed within a footprint of the lift-base assembly throughout movement of the seating unit; and a pair of generally mirror-image linkage mechanisms each moveably interconnecting each of the seat-mounting plates to a respective
10 base plate, and adapted to move the seating unit between a closed position, an extended position, and a reclined position, wherein each of the linkage mechanisms comprise: (a) a back-mounting link rotatably coupled to a respective seat-mounting plate and configured to support a backrest of the seating unit; (b) a back-support link pivotably coupled to the back-mounting link and to a rearward portion of a respective base plate; and (c) a rear lift link
15 rotatably coupled to a respective seat-mounting plate and pivotably coupled to the rearward portion of a respective base plate; (d) a connector link that includes a front end and a rear end, wherein the rear end of the connector link is pivotably coupled with the rear lift link; (e) a front lift link that is rotatably coupled to a respective seat-mounting plate, wherein the front end of the connector link is pivotably coupled to the front lift link; and (f) a front pivot link
20 that includes an upper end and a lower end, wherein the upper end of the front pivot link is pivotably coupled to the front lift link, and wherein the lower end of the front pivot link is pivotably coupled to a forward portion of a respective base plate.

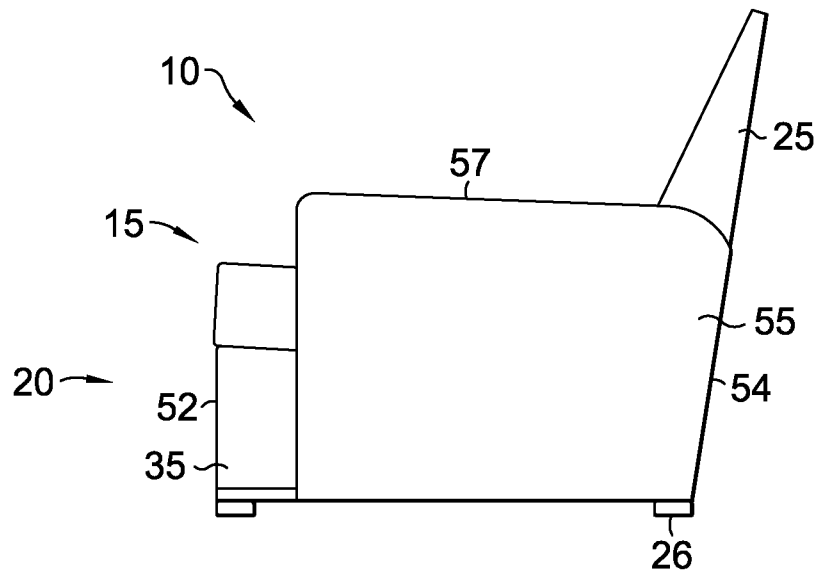

FIG. 1.

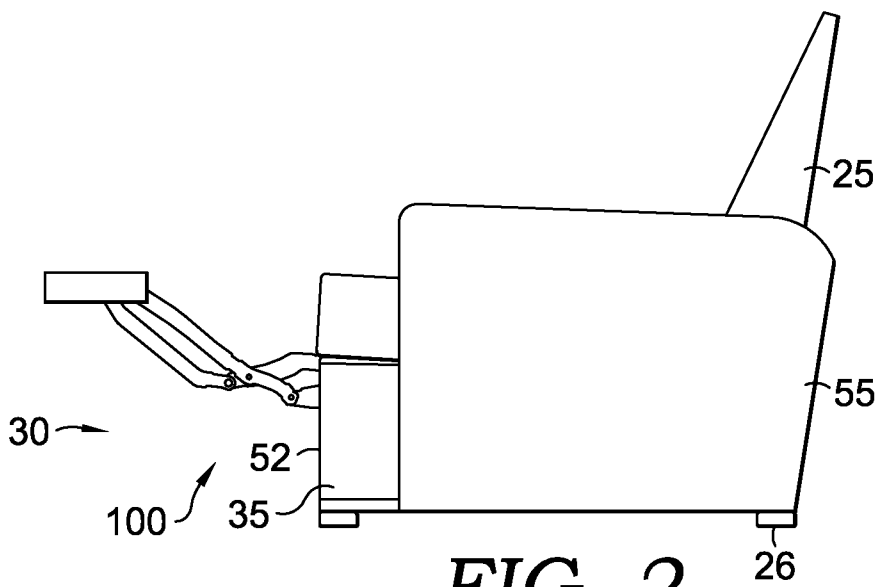

FIG. 2.

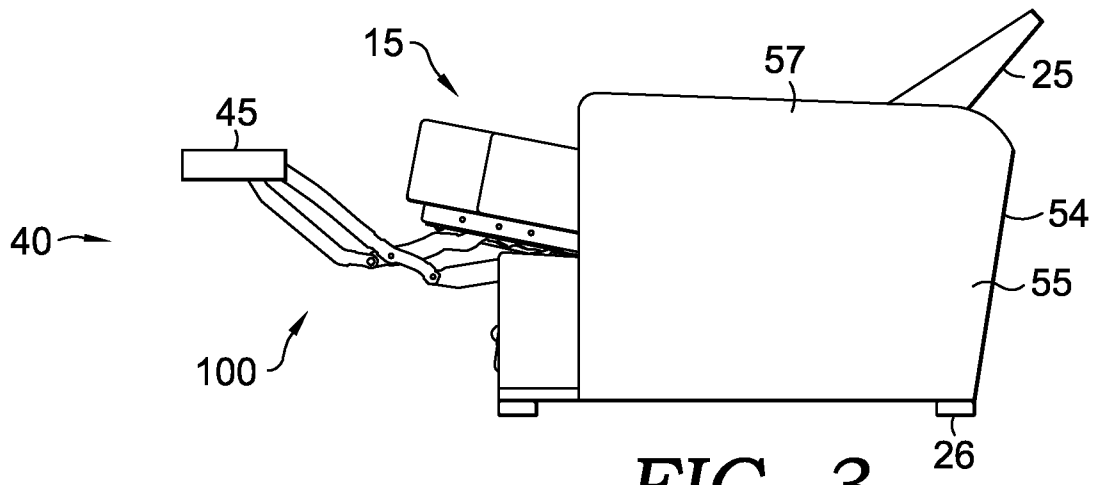

FIG. 3.

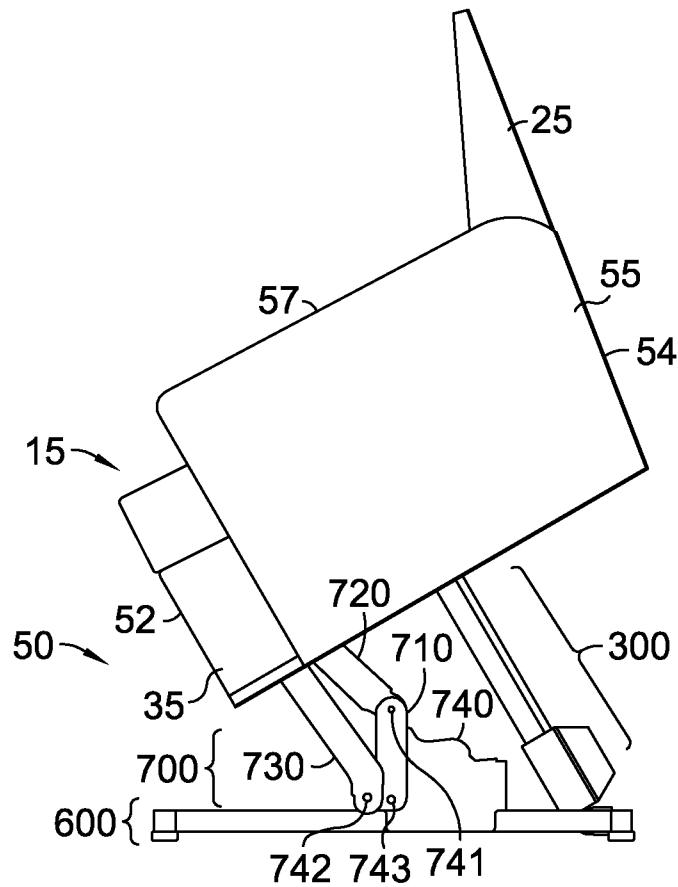

FIG. 4.

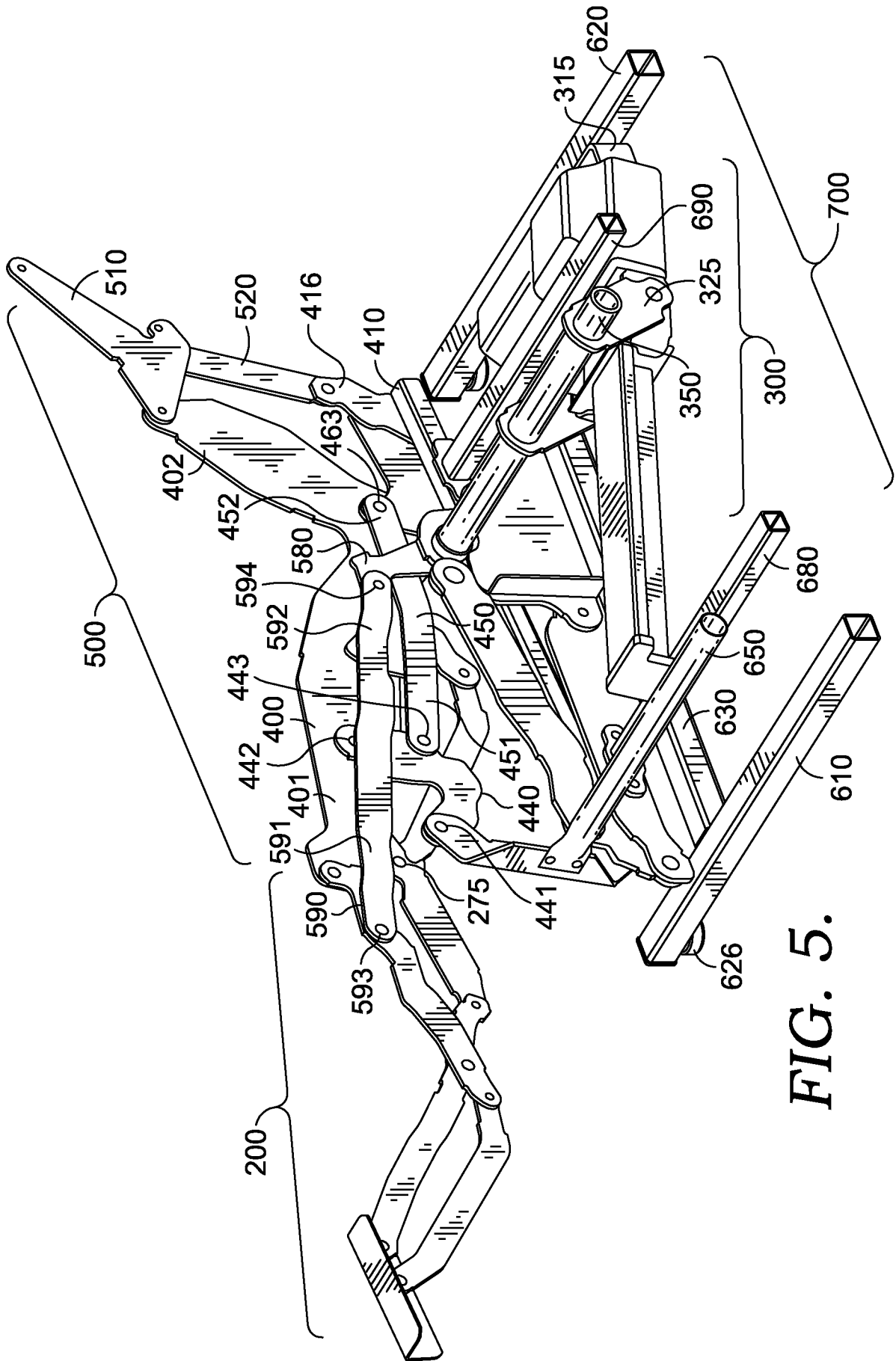

FIG. 5.

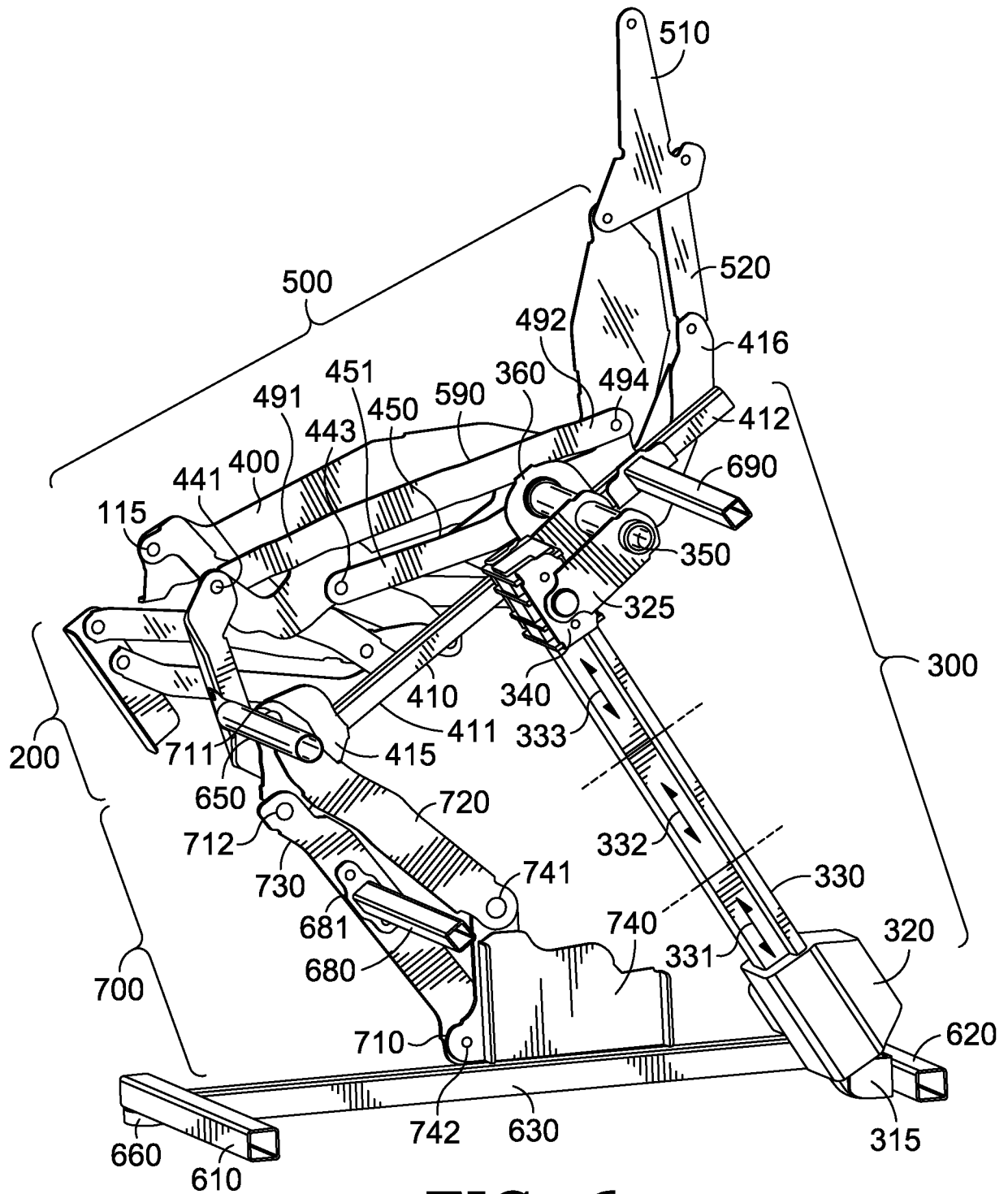

FIG. 6.

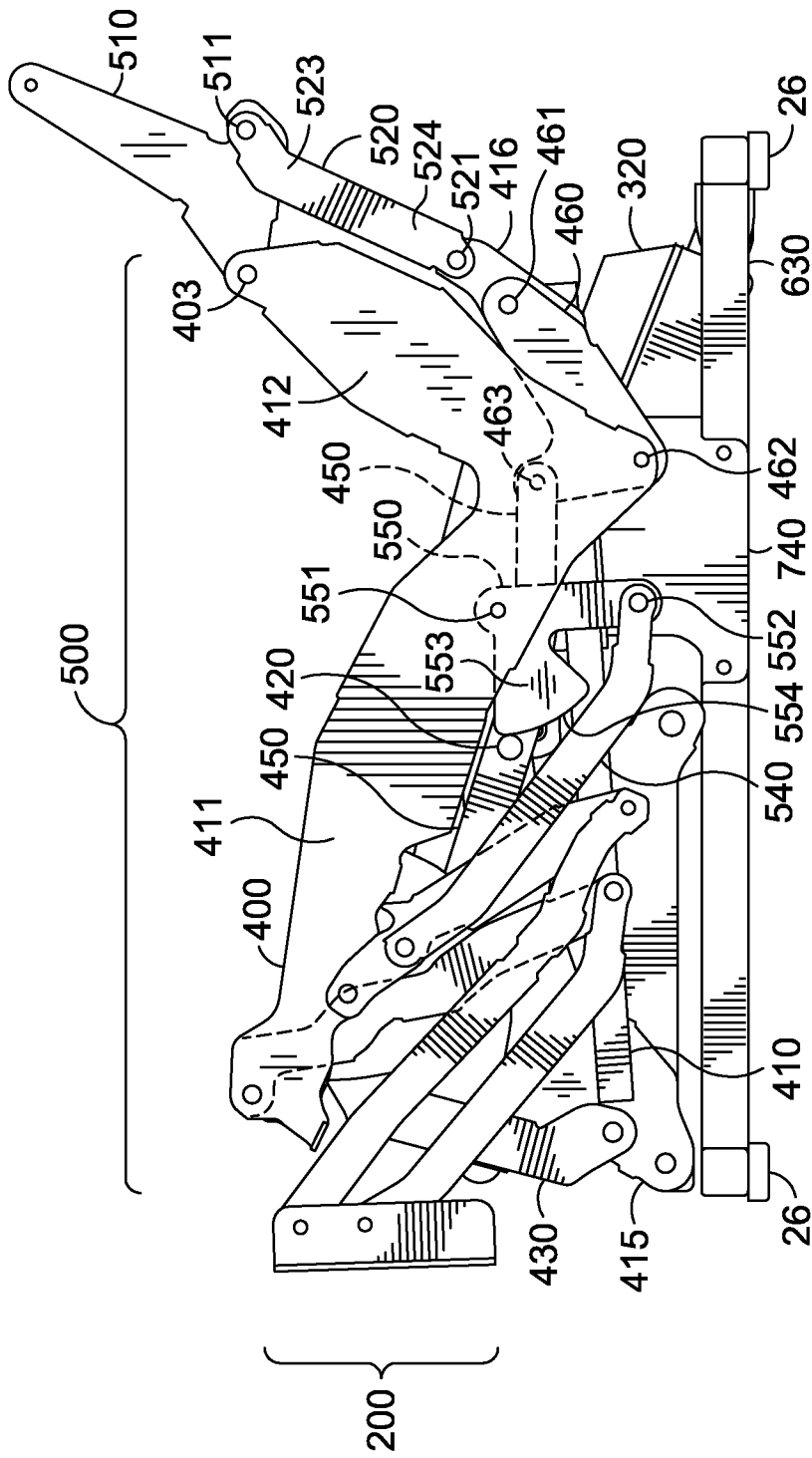
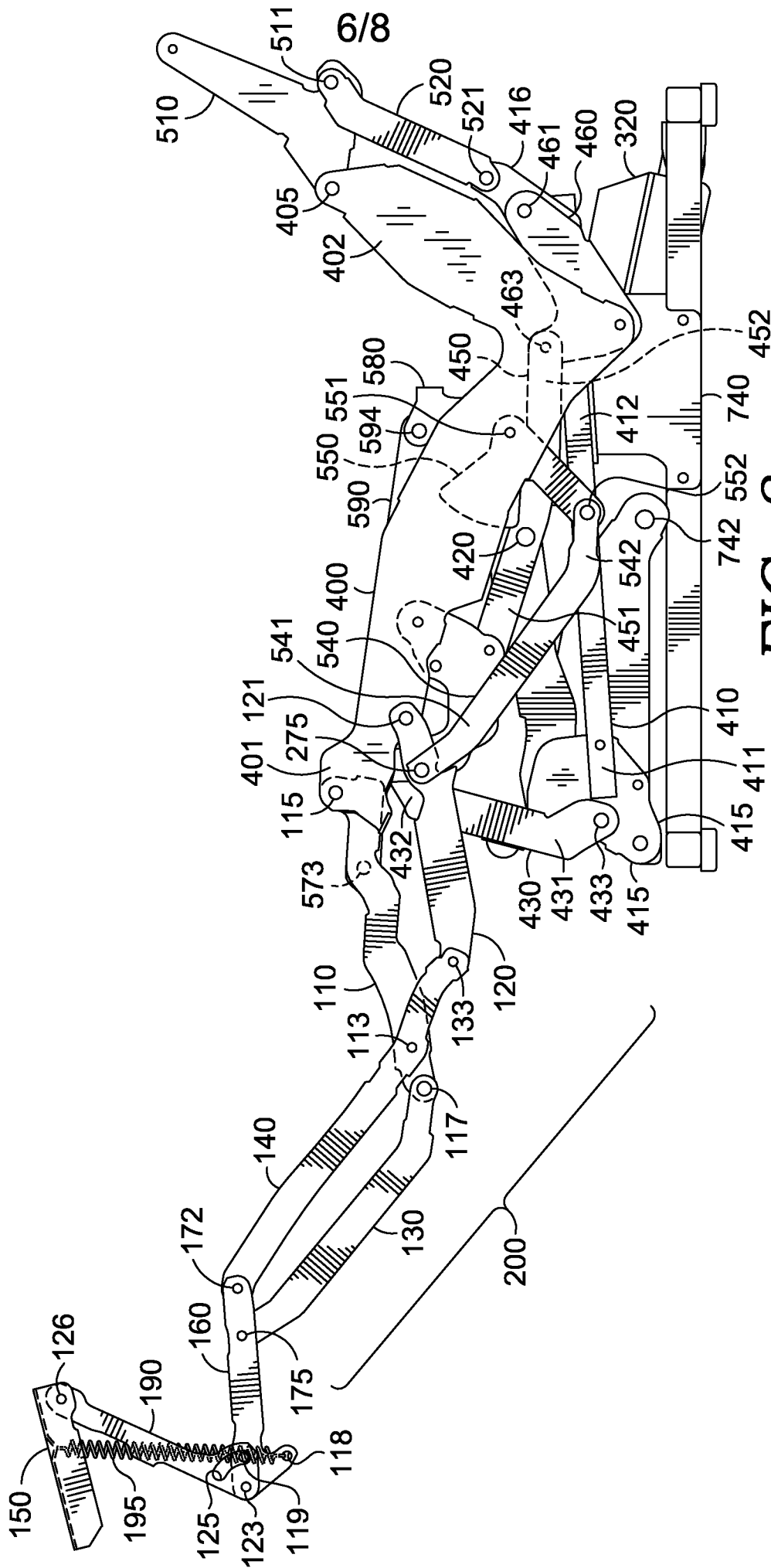

FIG. 7.



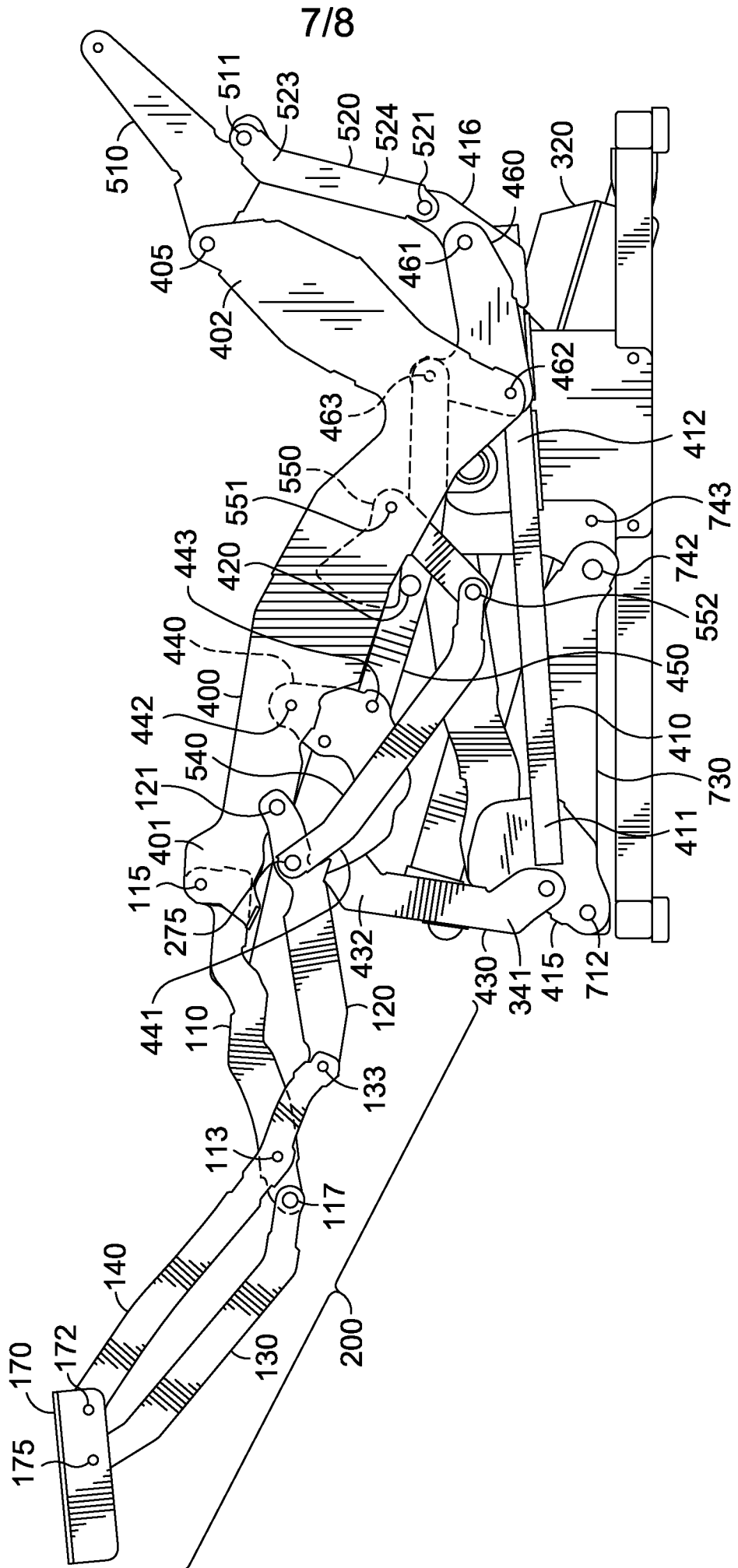

FIG. 9.

INTERNATIONAL SEARCH REPORT

International application No.

PCT/US20 13/020273

A. CLASSIFICATION OF SUBJECT MATTER

IPC(8) - A47C 1/02 (2013.01)
USPC - 297/330

According to International Patent Classification (IPC) or to both national classification and IPC

B. FIELDS SEARCHED

Minimum documentation searched (classification system followed by classification symbols)

IPC(8) - A47C 1/02, 1/035 (2013.01)
USPC - 74/469, 567; 297/71, 83, 84, 85M, 319, 330, 331, 335, 340

Documentation searched other than minimum documentation to the extent that such documents are included in the fields searched

CPC - A47C 1/02, 1/035 (2013.01)

Electronic data base consulted during the international search (name of data base and, where practicable, search terms used)

PatBase, Google Patents

C. DOCUMENTS CONSIDERED TO BE RELEVANT

Category*	Citation of document, with indication, where appropriate, of the relevant passages	Relevant to claim No.
X ---	US 201 1/0193373 A 1 (LAWSON et al) 11 August 201 1 (11.08.201 1) entire document	1-3 -----
Y	US 4,786,107 A (CROCKETT) 22 November 1988 (22.1 1.1988) entire document	4-20
Y	US 4,786,107 A (CROCKETT) 22 November 1988 (22.1 1.1988) entire document	4-13, 15-19
Y	US 2003/0047973 A 1 (PELLERIN) 13 March 2003 (13.03.2003) entire document	5-13, 16-20
Y	US 3,084,974 A (BELISLE et al) 09 April 1963 (09.04.1963) entire document	6-19

Further documents are listed in the continuation of Box C.

* Special categories of cited documents:

"A" document defining the general state of the art which is not considered to be of particular relevance
"E" earlier application or patent but published on or after the international filing date
"L" document which may throw doubts on priority claim(s) or which is cited to establish the publication date of another citation or other special reason (as specified)
"O" document referring to an oral disclosure, use, exhibition or other means
"P" document published prior to the international filing date but later than the priority date claimed

"T" later document published after the international filing date or priority date and not in conflict with the application but cited to understand the principle or theory underlying the invention
"X" document of particular relevance; the claimed invention cannot be considered novel or cannot be considered to involve an inventive step when the document is taken alone
"Y" document of particular relevance; the claimed invention cannot be considered to involve an inventive step when the document is combined with one or more other such documents, such combination being obvious to a person skilled in the art
"&" document member of the same patent family

Date of the actual completion of the international search

19 February 2013

Date of mailing of the international search report

0 1 MAR 2013

Name and mailing address of the ISA/US

Mail Stop PCT, Attn: ISA/US, Commissioner for Patents
P.O. Box 1450, Alexandria, Virginia 22313-1450
Facsimile No. 571-273-3201

Authorized Officer:

Blaine R. Copenheaver

PCT Helpdesk: 571-272-4300
PCT OSP: 571-272-7774